



MODEL T10023 ACCESSORY KIT #1 FOR T10010/T10097 WET GRINDER INSTRUCTION SHEET

Introduction

The Model T10023 Accessory Kit #1 for the Model T10010/T10097 Wet Grinder includes fixtures for sharpening small knives, large knives, scissors and axes.

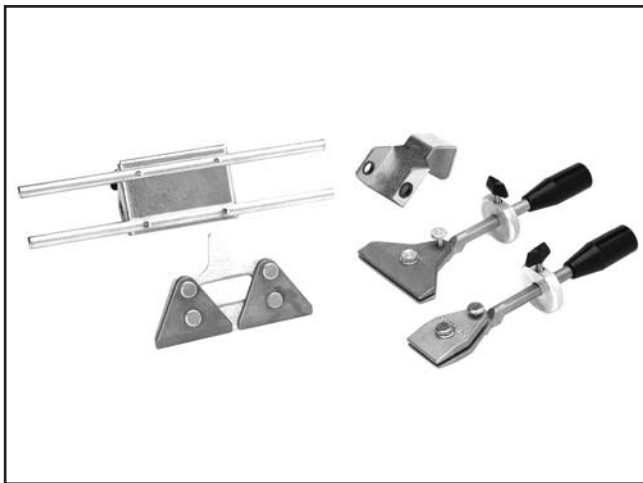

Figure 1. T10023 Accessory Kit

Unpacking

The Model T10023 Accessory Kit was carefully packed when it left our warehouse. If you discover any parts are damaged after you have signed for delivery, *please immediately call Customer Service at (570) 546-9663 for advice.* Save the containers and all packing materials for possible inspection by the carrier or its agent. *Otherwise, filing a freight claim can be difficult.* When you are completely satisfied with the condition of your shipment, you should inventory the contents.

Inventory (Figure 2)

- A. Scissors Sharpening Jig..... 1
- B. Axe Sharpening Jig 1
- C. Scissors Clamp 1
- D. Large Knife Sharpening Jig..... 1
- E. Scissors Sharpening Jig Knobs 2
- F. Knife Sharpening Jig Knobs..... 2
- G. Small Knife Sharpening Jig..... 1

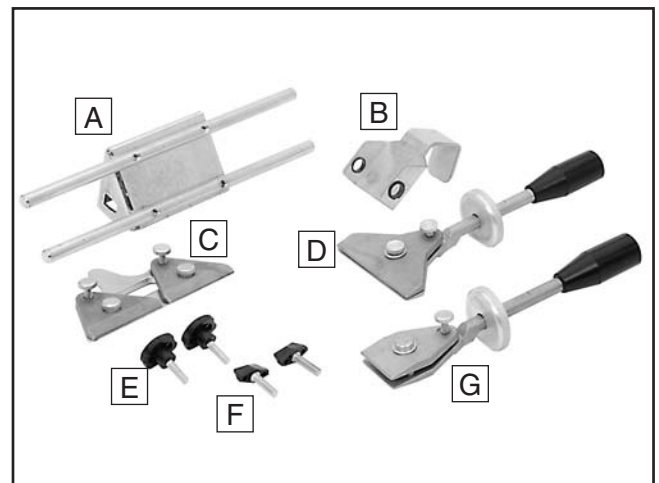

Figure 2. Inventory.

⚠ CAUTION

Adhere to all safety warnings outlined in the Model T10010/T10097 Wet Grinder user manual. If you are not familiar with the proper usage of the Model T10010/T10097 Wet Grinder, review the procedures and safety warnings covered in that manual. Failure to do so could result in damage to the machine or personal injury.

Assembling Knife Sharpening Jigs

1. Rotate the adjusting ring on the both jig shafts so that the flat portions are aligned (**Figure 3**).

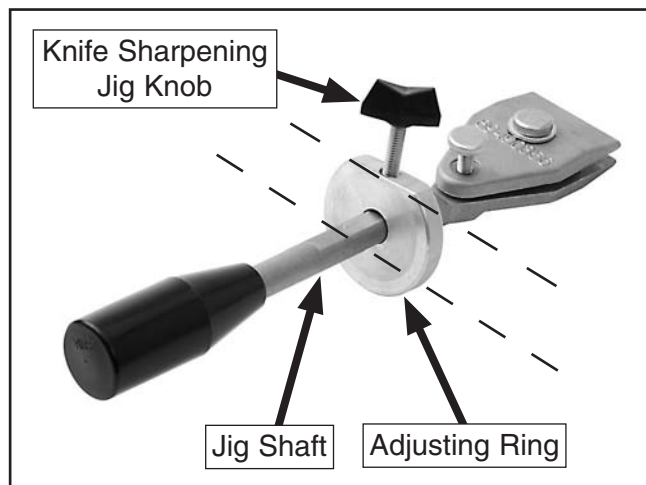

Figure 3. Knife jig assembly.

2. Thread the knife sharpening jig knobs into the adjusting rings on both jigs until they are tight.

Assembling Scissors Sharpening Jig

1. Assemble the jig as shown in **Figure 4**. Thread the jig knobs into the scissors sharpening jig only far enough so that they stay in place and will not interfere with sliding the jig onto the universal support.

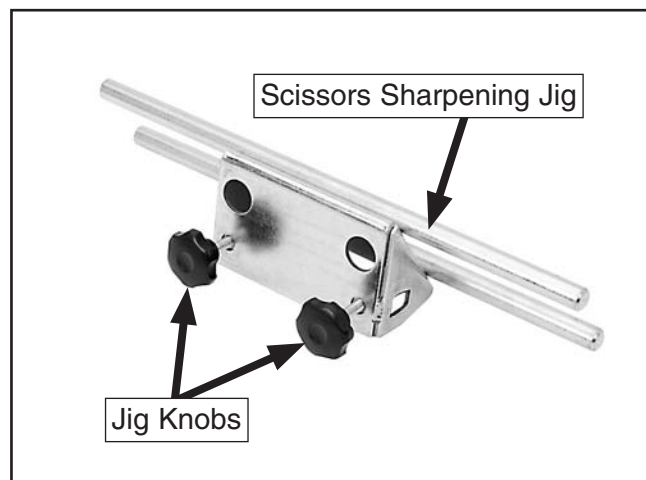

Figure 4. Scissor jig assembly.

Using the Axe Sharpening Jig

1. UNPLUG THE GRINDER FROM POWER!
2. Place the universal support in the vertical mounts on the grinder so that the grinding will occur against the rotation direction.
3. Slide the axe sharpening jig onto the universal support and insert the axe into the jig as shown in **Figure 5**.

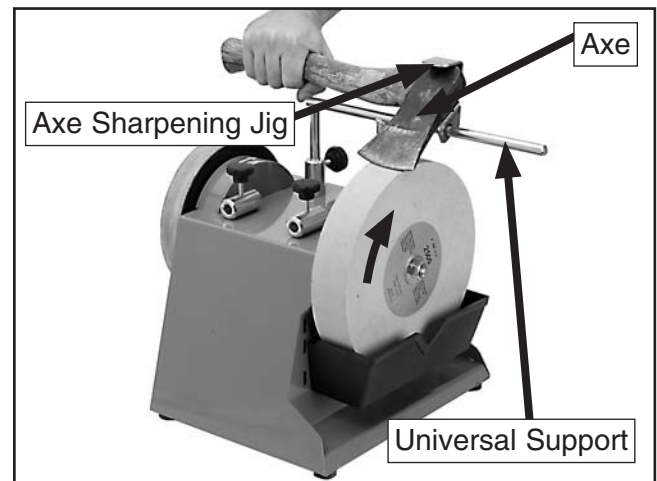

Figure 5. Axe sharpening.

4. Adjust the grinding angle by raising or lowering the universal support. Tighten all knobs and connect to power before grinding.

Tips for using the axe sharpening jig:

- Adjust the universal support vertically to achieve the desired grinding angle.
- Rock the axe handle back and forth rather than sliding it to sharpen the entire cutting edge of the axe.
- Always grind against the rotation direction of the grinding wheel.



Using the Knife Sharpening Jigs

For blades shorter than 4", use the small knife sharpening jig. For blades longer than 4", use the large sharpening jig.

1. UNPLUG THE GRINDER FROM POWER!
2. Place the universal support in the horizontal mounts on the grinder so that the grinding will occur with the rotation direction.
3. Loosen the clamping knob enough to allow the knife to slide in and loosen the lock knob far enough so that it does not extend through the clamp plate (**Figure 6**).

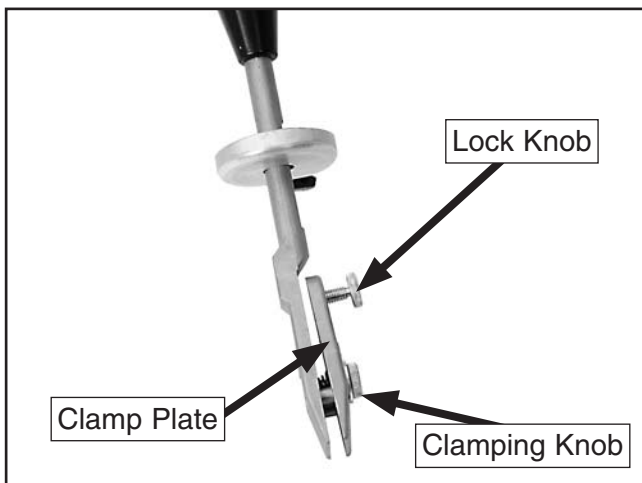

Figure 6. Knob identification.

4. Insert a knife into the clamp as shown in **Figure 7** and tighten the clamping knob.

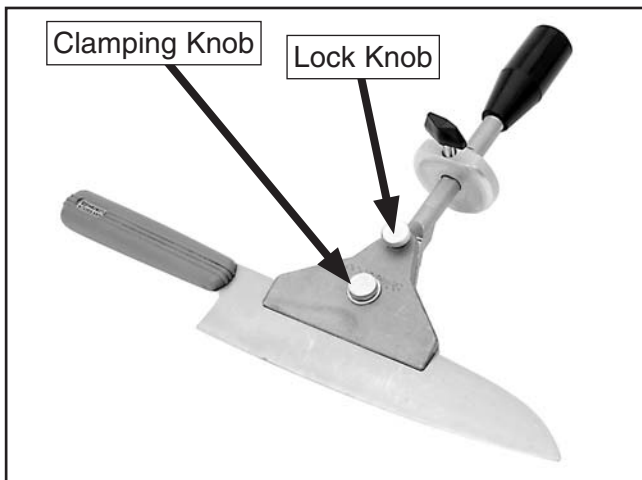

Figure 7. Knife clamping.

5. Tighten the lock knob to clamp the knife into the jig.
6. Adjust the position of the universal support to achieve the approximate grinding/stropping angle.
7. Adjust the position of the locking ring to fine tune the grinding/stropping angle (**Figure 8**).

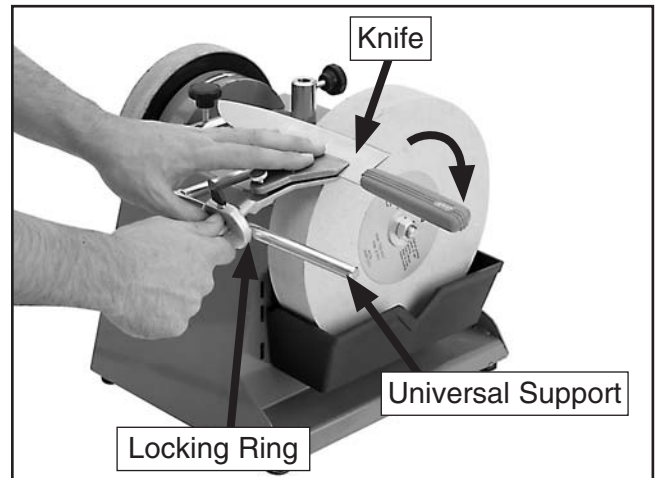

Figure 8. Knife sharpening.

8. Tighten all knobs before reconnecting the grinder to power to perform the operation.

Tips for using the knife sharpening jigs:

- Reposition the universal support for coarse angle adjustments.
- Reposition the lock ring on the knife sharpening jig for fine angle adjustments.
- Always grind with the direction of rotation of the grinding/stropping wheels
- Always use a smooth, stroking motion with even pressure, keeping the blade flat against the wheel for optimal results.
- Pivot the knife sharpening jig on the universal support as needed to follow the contour of the knife blade.



Using the Scissors Sharpening Jig

1. UNPLUG THE GRINDER FROM POWER!
2. Place the universal support in the vertical mounts on the grinder, and adjust the universal support approximately 1" away from the grinding wheel.
3. Slide the scissors sharpening jig onto the universal support, as shown in **Figure 9**, and tighten the knobs.

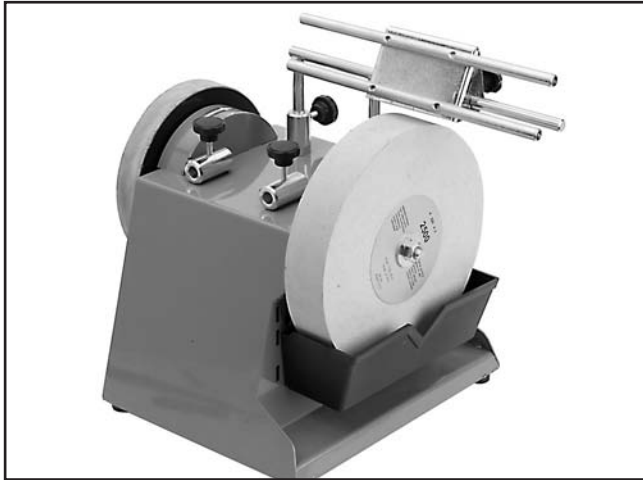

Figure 9. Scissors sharpening jig position.

4. Loosen the clamping knob enough to allow one blade of the scissor to slide in, and loosen the lock knob far enough so that it does not extend through the upper portion of the clamp (**Figure 10**).

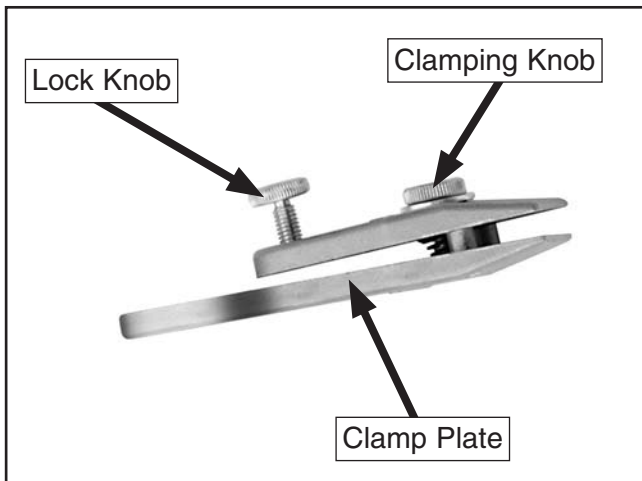

Figure 10. Scissors clamp knobs.

5. Insert one blade of the scissors into the clamp, as shown in **Figure 11**, and tighten the clamping knob.

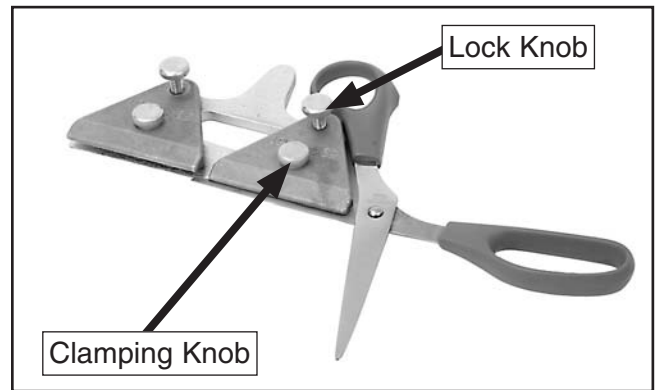

Figure 11. Scissors clamping.

6. Tighten the lock knob to securely clamp the scissors into the scissors clamp.
7. Place the scissors clamp on the rails of the sharpening jig. Adjust the height of the universal support or the angle of the sharpening jig as needed so that the clamp sits flat on both rails as shown in **Figure 12**.

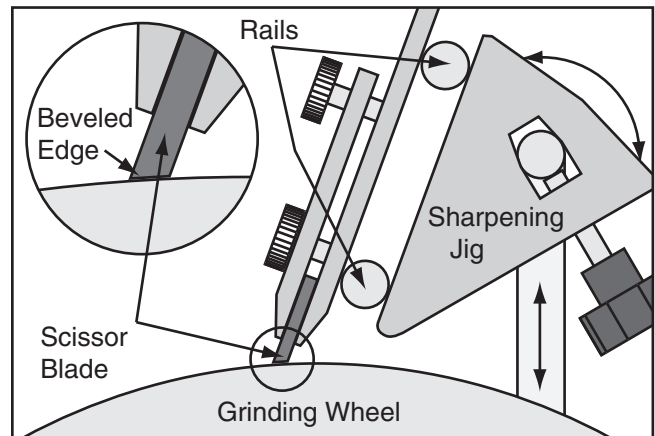

Figure 12. Scissors clamp placement.

8. Fine tune the position of the universal jig and the angle of the scissors jig until the beveled edge of the blade sits flat against the grinding wheel, as shown in **Figure 12**.
9. Tighten all knobs and reconnect the grinder to power before grinding.

Tips for using the scissors sharpening jig:

- Always use a smooth stroking motion with even pressure, keeping the blade flat against the wheel for optimal results.
- Do not use the stropping wheel with the universal support in the vertical mounts.



T10023 Parts Breakdown and List

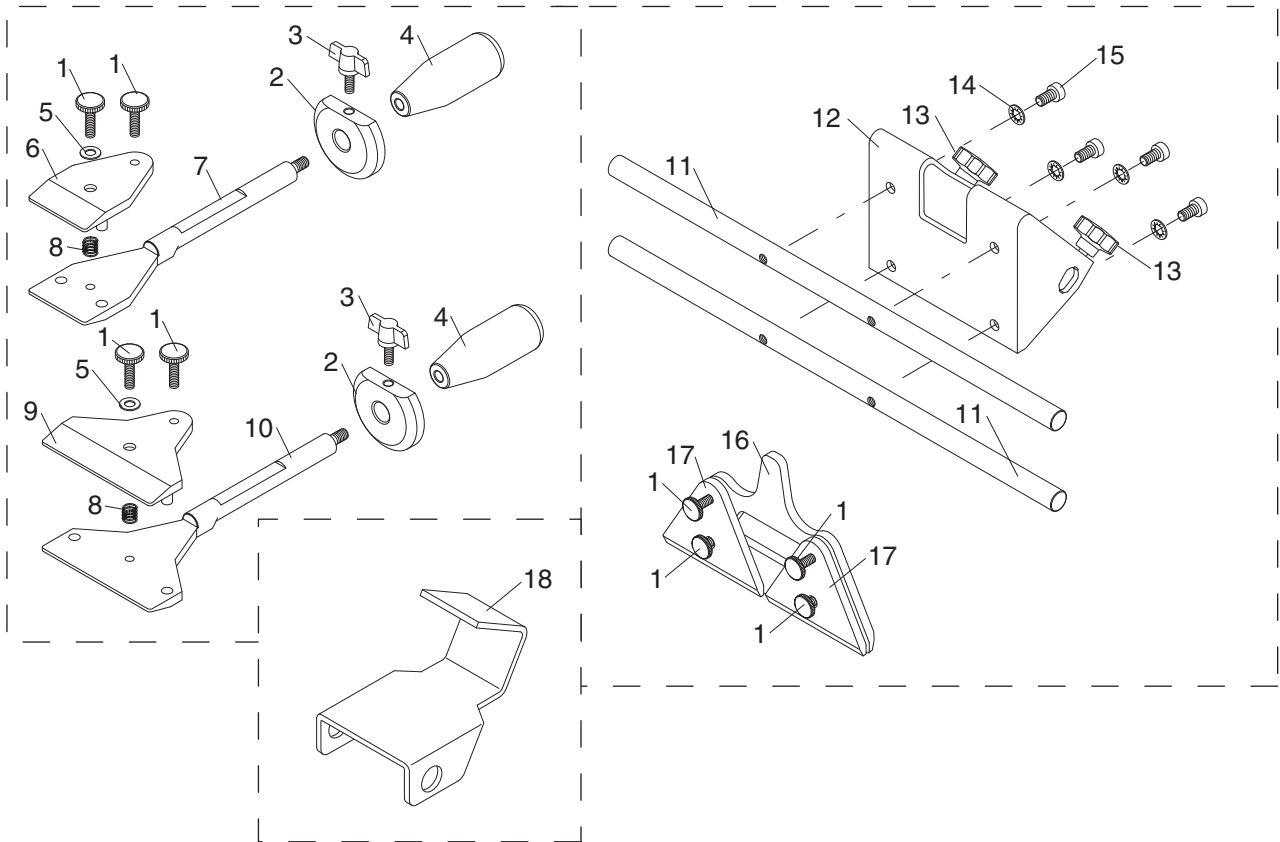

REF	PART #	DESCRIPTION
1	PT10023001	KNURLED SCREW M6-1 x 16
2	PT10023002	STOP RING
3	PT10023003	STOP RING KNOB
4	PT10023004	HANDLE
5	PW03M	FLAT WASHER 6MM
6	PT10023006	SMALL CLAMP PLATE
7	PT10023007	SMALL KNIFE SUPPORT
8	PT10023008	COMPRESSION SPRING
9	PT10023009	LARGE CLAMP PLATE

REF	PART #	DESCRIPTION
10	PT10023010	LARGE KNIFE SUPPORT
11	PT10023011	SCISSOR JIG RAIL
12	PT10023012	SCISSOR JIG HOLDER
13	PT10023013	SCISSOR JIG KNOB
14	PTLW13M	INT TOOTH WASHER 6MM
15	PSB26M	CAP SCREW M6-1 X 12
16	PT10023016	SCISSOR SUPPORT
17	PT10023017	SCISSOR CLAMP PLATE
18	PT10023018	AXE SHARPENING JIG

grizzly.com[®]

TOOL WEBSITE

Buy Direct and Save with Grizzly[®] – Trusted, Proven and a Great Value!
~Since 1983~

*Visit Our Website Today For
Current Specials!*

**ORDER
24 HOURS A DAY!
1-800-523-4777**

