



Automotive Networking Development Board User's Guide

Note the following details of the code protection feature on Microchip devices:

- Microchip products meet the specification contained in their particular Microchip Data Sheet.
- Microchip believes that its family of products is one of the most secure families of its kind on the market today, when used in the intended manner and under normal conditions.
- There are dishonest and possibly illegal methods used to breach the code protection feature. All of these methods, to our knowledge, require using the Microchip products in a manner outside the operating specifications contained in Microchip's Data Sheets. Most likely, the person doing so is engaged in theft of intellectual property.
- Microchip is willing to work with the customer who is concerned about the integrity of their code.
- Neither Microchip nor any other semiconductor manufacturer can guarantee the security of their code. Code protection does not mean that we are guaranteeing the product as "unbreakable."

Code protection is constantly evolving. We at Microchip are committed to continuously improving the code protection features of our products. Attempts to break Microchip's code protection feature may be a violation of the Digital Millennium Copyright Act. If such acts allow unauthorized access to your software or other copyrighted work, you may have a right to sue for relief under that Act.

Information contained in this publication regarding device applications and the like is provided only for your convenience and may be superseded by updates. It is your responsibility to ensure that your application meets with your specifications. MICROCHIP MAKES NO REPRESENTATIONS OR WARRANTIES OF ANY KIND WHETHER EXPRESS OR IMPLIED, WRITTEN OR ORAL, STATUTORY OR OTHERWISE, RELATED TO THE INFORMATION, INCLUDING BUT NOT LIMITED TO ITS CONDITION, QUALITY, PERFORMANCE, MERCHANTABILITY OR FITNESS FOR PURPOSE. Microchip disclaims all liability arising from this information and its use. Use of Microchip devices in life support and/or safety applications is entirely at the buyer's risk, and the buyer agrees to defend, indemnify and hold harmless Microchip from any and all damages, claims, suits, or expenses resulting from such use. No licenses are conveyed, implicitly or otherwise, under any Microchip intellectual property rights unless otherwise stated.

Microchip received ISO/TS-16949:2009 certification for its worldwide headquarters, design and wafer fabrication facilities in Chandler and Tempe, Arizona; Gresham, Oregon and design centers in California and India. The Company's quality system processes and procedures are for its PIC® MCUs and dsPIC® DSCs, KEELOQ® code hopping devices, Serial EEPROMs, microperipherals, nonvolatile memory and analog products. In addition, Microchip's quality system for the design and manufacture of development systems is ISO 9001:2000 certified.

**QUALITY MANAGEMENT SYSTEM
CERTIFIED BY DNV
= ISO/TS 16949 =**

Trademarks

The Microchip name and logo, the Microchip logo, AnyRate, dsPIC, FlashFlex, flexPWR, Heldo, JukeBlox, KeeLoq, KeeLoq logo, Klear, LANCheck, LINK MD, MediaLB, MOST, MOST logo, MPLAB, OptoLyzer, PIC, PICSTART, PIC32 logo, RightTouch, SpyNIC, SST, SST Logo, SuperFlash and UNI/O are registered trademarks of Microchip Technology Incorporated in the U.S.A. and other countries.

ClockWorks, The Embedded Control Solutions Company, ETHERSYNCH, Hyper Speed Control, HyperLight Load, IntelliMOS, mTouch, Precision Edge, and QUIET-WIRE are registered trademarks of Microchip Technology Incorporated in the U.S.A.

Analog-for-the-Digital Age, Any Capacitor, AnyIn, AnyOut, BodyCom, chipKIT, chipKIT logo, CodeGuard, dsPICDEM, dsPICDEM.net, Dynamic Average Matching, DAM, ECAN, EtherGREEN, In-Circuit Serial Programming, ICSP, Inter-Chip Connectivity, JitterBlocker, KlearNet, KlearNet logo, MiWi, motorBench, MPASM, MPF, MPLAB Certified logo, MPLIB, MPLINK, MultiTRAK, NetDetach, Omniscient Code Generation, PICDEM, PICDEM.net, PICkit, PICtail, PureSilicon, RightTouch logo, REAL ICE, Ripple Blocker, Serial Quad I/O, SQL, SuperSwitcher, SuperSwitcher II, Total Endurance, TSHARC, USBCheck, VariSense, ViewSpan, WiperLock, Wireless DNA, and ZENA are trademarks of Microchip Technology Incorporated in the U.S.A. and other countries.

SQTP is a service mark of Microchip Technology Incorporated in the U.S.A.

Silicon Storage Technology is a registered trademark of Microchip Technology Inc. in other countries.

GestIC is a registered trademark of Microchip Technology Germany II GmbH & Co. KG, a subsidiary of Microchip Technology Inc., in other countries.

All other trademarks mentioned herein are property of their respective companies.

© 2016, Microchip Technology Incorporated, Printed in the U.S.A., All Rights Reserved.

ISBN: 978-1-5224-1008-9

Object of Declaration: Automotive Networking Development Board

EU Declaration of Conformity

Manufacturer: Microchip Technology Inc.
2355 W. Chandler Blvd.
Chandler, Arizona, 85224-6199
USA

This declaration of conformity is issued by the manufacturer.

The development/evaluation tool is designed to be used for research and development in a laboratory environment. This development/evaluation tool is not a Finished Appliance, nor is it intended for incorporation into Finished Appliances that are made commercially available as single functional units to end users under EU EMC Directive 2004/108/EC and as supported by the European Commission's Guide for the EMC Directive 2004/108/EC (8th February 2010).

This development/evaluation tool complies with EU RoHS2 Directive 2011/65/EU.

This development/evaluation tool, when incorporating wireless and radio-telecom functionality, is in compliance with the essential requirement and other relevant provisions of the R&TTE Directive 1999/5/EC and the FCC rules as stated in the declaration of conformity provided in the module datasheet and the module product page available at www.microchip.com.

For information regarding the exclusive, limited warranties applicable to Microchip products, please see Microchip's standard terms and conditions of sale, which are printed on our sales documentation and available at www.microchip.com.

Signed for and on behalf of Microchip Technology Inc. at Chandler, Arizona, USA

Derek Carlson
VP Development Tools

12-Sep-14
Date

NOTES:



Table of Contents

Preface	7
Chapter 1. The Automotive Networking Development Board	
1.1 Introduction	11
1.2 Highlights	11
1.3 Kit Contents	11
1.4 Using the Automotive Networking Development Board for the First Time ...	11
1.5 Automotive Networking Development Board Functionality and Features	12
Chapter 2. Hardware	
2.1 Introduction	15
2.2 Hardware Features	15
2.2.1 Processor Support	15
2.2.2 Switches	15
2.2.3 Analog Input (Potentiometer)	15
2.2.4 LEDs	15
2.2.5 PICtail™ Plus Card Edge Modular Expansion Connectors	15
2.2.6 Pmod Connectors	16
2.3 Power Sources	16
2.3.1 USB Connector	16
2.3.2 Barrel Plug External Power Supply	16
2.3.3 Screw Terminal External Power Supply	16
2.4 On-Board Jumper Configurations	17
2.4.1 I2C	17
2.4.2 UART	17
2.4.3 SPI	18
2.4.4 CAN	18
2.4.5 mikroBUS™ Headers	19
2.5 Oscillator Configurations	20
2.5.1 Default Resonator (MEMS resonator)	20
2.5.2 Optional Oscillator (Various sources)	20
2.6 Programming the board	20
2.6.1 ICD	20
2.6.2 PICkit™ Programmer connector	20
Chapter 3. Software	
3.1 Introduction	21
3.2 Software Overview	21

Chapter 4. Troubleshooting Common Problems

4.1 Programming Issues	23
4.1.1 Programming of the PIM Module has Failed	23
4.1.1.1 Cause 1	23
4.1.1.2 Solution 1	23
4.1.1.3 Cause 2	23
4.1.1.4 Solution 2	23

Appendix A. Schematics

A.1 Introduction	25
A.2 Development Board Block Diagram	25
A.3 Development Board Schematics	26

Worldwide Sales and Service	29
--	-----------



Preface

NOTICE TO CUSTOMERS

All documentation becomes dated, and this manual is no exception. Microchip tools and documentation are constantly evolving to meet customer needs, so some actual dialogs and/or tool descriptions may differ from those in this document. Please refer to our website (www.microchip.com) to obtain the latest documentation available.

Documents are identified with a “DS” number. This number is located on the bottom of each page, in front of the page number. The numbering convention for the DS number is “DSXXXXA”, where “XXXX” is the document number and “A” is the revision level of the document.

For the most up-to-date information on development tools, see the MPLAB® IDE online help. Select the Help menu, and then Topics to open a list of available online help files.

INTRODUCTION

This chapter contains general information that will be useful to know before using the Automotive Networking Development Board. Items discussed in this chapter include:

- [Document Layout](#)
- [Conventions Used in this Guide](#)
- [Warranty Registration](#)
- [Recommended Reading](#)
- [The Microchip Website](#)
- [Development Systems Customer Change Notification Service](#)
- [Customer Support](#)
- [Revision History](#)

DOCUMENT LAYOUT

This document describes how to use the Automotive Networking Development Board as a development tool to emulate and debug firmware on a target board, as well as how to program devices. The document is organized as follows:

- [Chapter 1. “The Automotive Networking Development Board”](#)
- [Chapter 2. “Hardware”](#)
- [Chapter 3. “Software”](#)
- [Chapter 4. “Troubleshooting Common Problems”](#)
- [Appendix A. “Schematics”](#)

CONVENTIONS USED IN THIS GUIDE

This manual uses the following documentation conventions:

DOCUMENTATION CONVENTIONS

Description	Represents	Examples
Arial font:		
Italic characters	Referenced books	<i>MPLAB[®] IDE User's Guide</i>
	Emphasized text	...is the <i>only</i> compiler...
Initial caps	A window	the Output window
	A dialog	the Settings dialog
	A menu selection	select Enable Programmer
Quotes	A field name in a window or dialog	"Save project before build"
Underlined, italic text with right angle bracket	A menu path	<u><i>File>Save</i></u>
Bold characters	A dialog button	Click OK
	A tab	Click the Power tab
N'Rnnnn	A number in verilog format, where N is the total number of digits, R is the radix and n is a digit.	4'b0010, 2'hF1
Text in angle brackets < >	A key on the keyboard	Press <Enter>, <F1>
Courier New font:		
Plain Courier New	Sample source code	#define START
	Filenames	autoexec.bat
	File paths	c:\mcc18\h
	Keywords	_asm, _endasm, static
	Command-line options	-Opa+, -Opa-
	Bit values	0, 1
	Constants	0xFF, 'A'
Italic Courier New	A variable argument	<i>file.o</i> , where <i>file</i> can be any valid filename
Square brackets []	Optional arguments	mcc18 [options] <i>file</i> [options]
Curly brackets and pipe character: { }	Choice of mutually exclusive arguments; an OR selection	errorlevel {0 1}
Ellipses...	Replaces repeated text	var_name [, var_name...]
	Represents code supplied by user	void main (void) { ... }

WARRANTY REGISTRATION

Please complete the enclosed Warranty Registration Card and mail it promptly. Sending in the Warranty Registration Card entitles users to receive new product updates. Interim software releases are available at the Microchip website.

RECOMMENDED READING

This user's guide describes how to use the Automotive Networking Development Board. Other useful documents are listed below. The following Microchip documents are available and recommended as supplemental reference resources.

Release Notes for MPLAB® ICD 3 In-Circuit Debugger

For the latest information on using the Automotive Networking Development Board, read the "Readme for Automotive Networking Development Board.htm" file (an HTML file) in the Readmes subdirectory of the MPLAB IDE installation directory. The release notes (Readme) contains update information and known issues that may not be included in this user's guide.

THE MICROCHIP WEBSITE

Microchip provides online support via our website at www.microchip.com. This website is used as a means to make files and information easily available to customers. Accessible by using your favorite Internet browser, the website contains the following information:

- **Product Support** – Data sheets and errata, application notes and sample programs, design resources, user's guides and hardware support documents, latest software releases and archived software
- **General Technical Support** – Frequently Asked Questions (FAQs), technical support requests, online discussion groups, Microchip consultant program member listing
- **Business of Microchip** – Product selector and ordering guides, latest Microchip press releases, listing of seminars and events, listings of Microchip sales offices, distributors and factory representatives

DEVELOPMENT SYSTEMS CUSTOMER CHANGE NOTIFICATION SERVICE

Microchip's customer notification service helps keep customers current on Microchip products. Subscribers will receive e-mail notification whenever there are changes, updates, revisions or errata related to a specified product family or development tool of interest.

To register, access the Microchip website at www.microchip.com, click on Customer Change Notification and follow the registration instructions.

The Development Systems product group categories are:

- **Compilers** – The latest information on Microchip C compilers, assemblers, linkers and other language tools. These include all MPLAB C compilers; all MPLAB assemblers (including MPASM™ assembler); all MPLAB linkers (including MPLINK™ object linker); and all MPLAB librarians (including MPLIB™ object librarian).
- **Emulators** – The latest information on Microchip in-circuit emulators. This includes the MPLAB REAL ICE™ and MPLAB ICE 2000 in-circuit emulators.
- **In-Circuit Debuggers** – The latest information on the Microchip in-circuit debuggers. This includes MPLAB ICD 3 in-circuit debuggers and PICKit™ 3 debug express.

- **MPLAB® IDE** – The latest information on Microchip MPLAB IDE, the Windows® Integrated Development Environment for development systems tools. This list is focused on the MPLAB IDE, MPLAB IDE Project Manager, MPLAB Editor and MPLAB SIM simulator, as well as general editing and debugging features.
- **Programmers** – The latest information on Microchip programmers. These include production programmers such as MPLAB REAL ICE in-circuit emulator, MPLAB ICD 3 in-circuit debugger and MPLAB PM3 device programmers. Also included are nonproduction development programmers such as PICSTART® Plus and PICkit 2 and 3.

CUSTOMER SUPPORT

Users of Microchip products can receive assistance through several channels:

- Distributor or Representative
- Local Sales Office
- Field Application Engineer (FAE)
- Technical Support

Customers should contact their distributor, representative or field application engineer (FAE) for support. Local sales offices are also available to help customers. A listing of sales offices and locations is included in the back of this document.

Technical support is available through the website at:

<http://www.microchip.com/support>.

REVISION HISTORY

Revision A (10/2016)

This is the initial release of this document.

Chapter 1. The Automotive Networking Development Board

1.1 INTRODUCTION

The CAN, LIN, CAN-FD Automotive Networking Development Board provides a low-cost modular platform for CAN, LIN, CAN-FD network development using 8-bit, 16-bit, and 32-bit Microchip microcontroller families. It features four mikroBUS™ headers to accommodate a variety of plug-in Click™ Board combinations for LIN, CAN, and CAN-FD development. The Automotive Networking Development Board supports CAN and CAN-FD natively. The CAN digital connection from the microcontroller connects to the TX/RX connection on the mikroBUS™ header. This connection supports the CAN and CAN-FD Transceiver Click™ boards without having to lose the microcontroller UART connection to the other mikroBUS™ headers.

1.2 HIGHLIGHTS

This chapter covers the following topics:

- Kit Contents
- Using the Automotive Networking Development Board for the First Time
- Automotive Networking Development Board Functionality and Features

1.3 KIT CONTENTS

The Automotive Networking Development Board kit contains the following:

- The Automotive Networking Development Board
- Jumpers (15 jumpers pre-placed onto the board)
- The kit **does NOT** contain a processor PIM (Plug-in Module)
- The kit **does NOT** contain a power supply

1.4 USING THE AUTOMOTIVE NETWORKING DEVELOPMENT BOARD FOR THE FIRST TIME

The Automotive Networking Development Board kit does not contain a processor PIM. The user will need to acquire a processor PIM. Refer to www.microchip.com for supported PIMs and example projects.

To get started with the board, the user needs to:

- Verify that a PIM is correctly installed onto the board. All PIMs should be aligned so that the notched corner marking is oriented in the lower left corner

CAUTION

The power supply provides +3.3V and +5V (regulated) to the entire board. The switch S6 will determine whether the processor PIM will receive +3.3V or +5V. Do NOT power a 3.3V PIM with 5V.

Automotive Networking Development Board User's Guide

- Power the Automotive Networking Development Board. The board can be powered with a USB connection or a DC (7-30V) power supply. To enable power over the USB connector, place a jumper on pins 1 and 2 of connector J28. To enable power from a DC supply through the barrel jack connector or screw terminal, place the jumper on pins 2 and 3 of J28
- Verify that the jumper on JP2 is installed (to enable the LEDs)
- Program the PIM with the example code found on www.microchip.com

1.5 AUTOMOTIVE NETWORKING DEVELOPMENT BOARD FUNCTIONALITY AND FEATURES

FIGURE 1-1: AUTOMOTIVE NETWORKING DEVELOPMENT BOARD

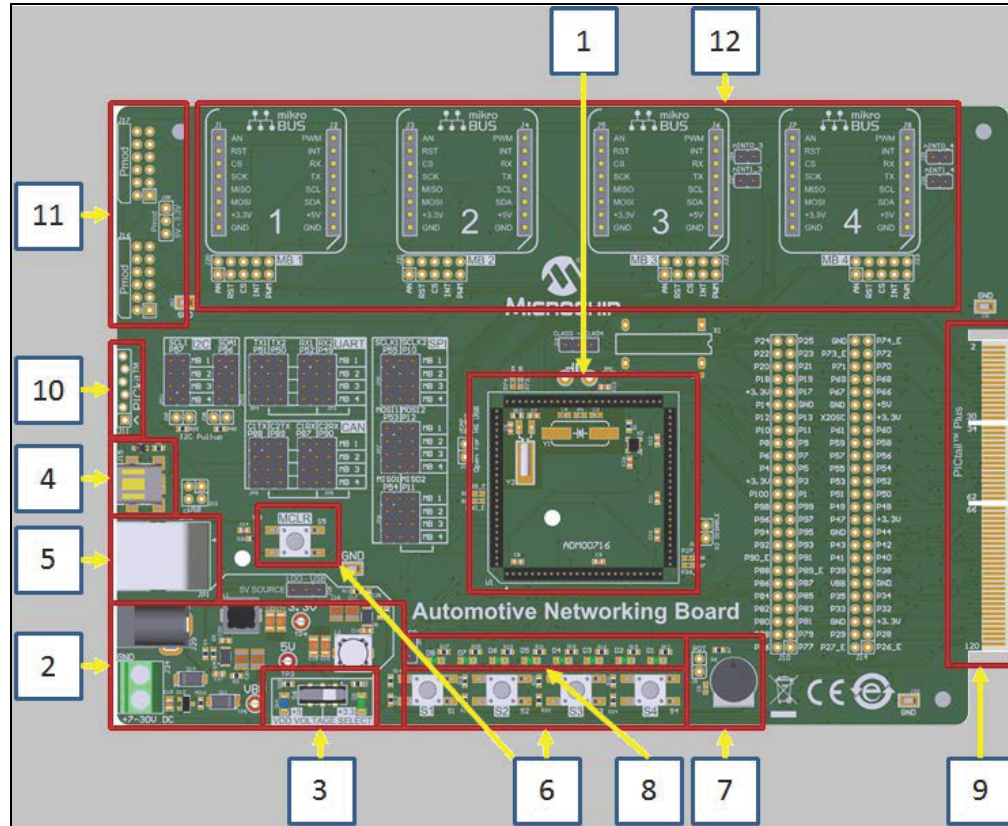

A layout of the Automotive Networking Development Board is shown in Figure 1-1. The board includes the key features mentioned below, as indicated in the diagram:

1. 100-pin PIM header, compatible with the PIM versions of selected PIC[®] MCU and dsPIC[®] DSC devices
2. Direct 7-30V DC power input that provides +3.3V and +5V (regulated) to the entire board
3. Power indicator LED will represent what voltage is applied to the processor PIM. For additional details refer to [Section 2.3 “Power Sources”](#).
4. USB connector for connectivity with MCUs that have a USB module
5. Standard 6-wire In-Circuit Debugger (ICD) connector for connections to an MPLAB[®] ICD programmer/debugger module

The Automotive Networking Development Board

6. Push button switches for device Reset and user-defined inputs
7. Potentiometer for analog input
8. Eight indicator LEDs
9. Edge connector for PICtail™ Plus card compatibility
10. Six-pin interface for the PICKit™ Programmer
11. Two Pmod interfaces
12. Four mikroBUS™ headers

For additional details on these features, refer to [Chapter 2. “Hardware”](#).

FIGURE 1-2: TOP VIEW OF THE BOARD

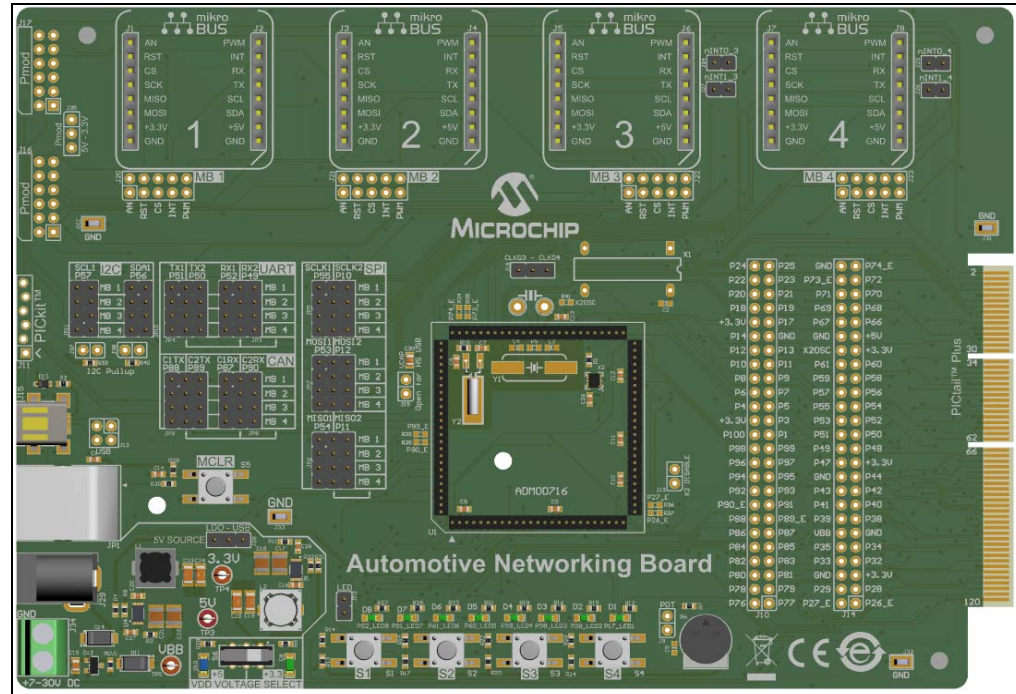
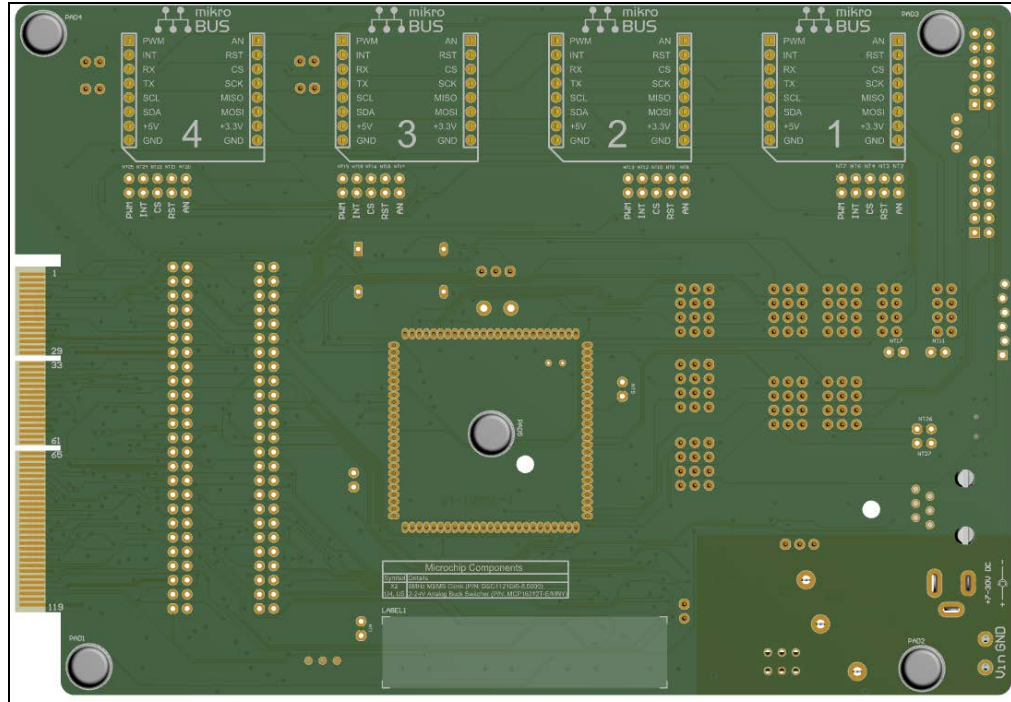

FIGURE 1-3: BOTTOM VIEW OF THE BOARD



Chapter 2. Hardware

2.1 INTRODUCTION

This chapter provides a more detailed description of the hardware features of the Automotive Networking Development Board.

2.2 HARDWARE FEATURES

The key features of the Automotive Networking Development Board are listed below.

2.2.1 Processor Support

The Automotive Networking Development Board has been designed to accommodate detachable 100-pin processor PIM modules. This makes it possible for the Automotive Networking Development Board to support most 3.3V or 5V PIC[®] MCUs and dsPIC[®] DSCs with appropriate PIMs. The PIM is always installed with the notched corner mark on the corner of the PIM board oriented to the lower left corner.

2.2.2 Switches

Five push button switches provide the following functions:

- S1: Active-low switch
- S2: Active-low switch
- S3: Active-low switch
- S4: Active-low switch
- S5: Active-low MCLR switch to hard reset the processor

When Idle, the switches are pulled high; when pressed, they are grounded.

2.2.3 Analog Input (Potentiometer)

A 10 kW potentiometer is connected through a series resistor. It can be adjusted from VDD to GND to provide an analog input to one of the controller's A/D channels.

2.2.4 LEDs

Eight LEDs (D1 through D8) are available. Set the pins output high to light the LEDs. These LEDs may be disabled by removing jumper JP2.

2.2.5 PICtail™ Plus Card Edge Modular Expansion Connectors

The Automotive Networking Development Board has been designed with the PICtail™ Plus modular expansion interface, allowing the board to provide basic generic functionality and still be easily extendable to new technologies as they become available.

2.2.6 Pmod Connectors

The Automotive Networking Development board has two Pmod ports to provide support to Digilent lines of small peripheral interface modules. The Pmod ports J16 and J17 have the same pinout as shown in [Figure 2-1](#) below.

FIGURE 2-1: Pmod CONNECTOR INTERFACE

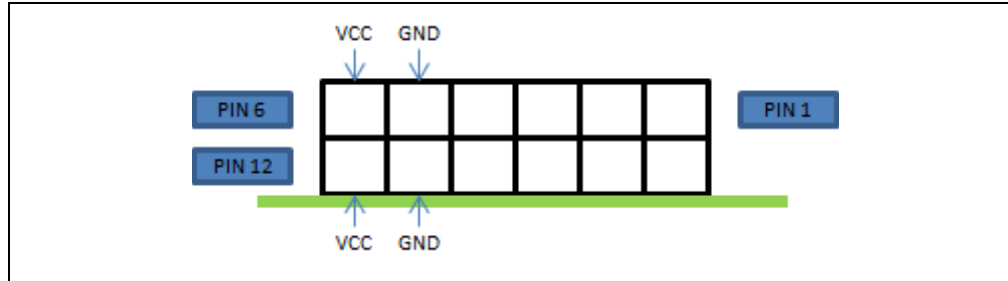

2.3 POWER SOURCES

2.3.1 USB Connector

The USB connector (J15) will power the Automotive Networking Development Board. A jumper must be placed onto J28 (pins 1 and 2) to connect +5V from the USB connector J15. Switch S6 will need to be set to 3.3V or 5V based on the user requirement. When USB power is connected to J15, the power LED D9 or D10 will always be ON to indicate that +3.3V or +5V is available to the PIM module header on the board.

2.3.2 Barrel Plug External Power Supply

The Barrel Plug connector (J29) will power the Automotive Networking Development Board. A jumper must be placed onto J28 (pins 2 and 3) to connect the output from the switching power supply circuit to 5V. When power is connected to J29 the power LED D9 or D10 will always be ON to indicate that +3.3V or +5V is available to the PIM module header on the board. To set the voltage delivered to the micro on the PIM, switch S6 will need to be set to 3.3V or 5V based on the user's requirements. The supported external power range applied to the barrel plug is 7 to 30V.

Note: When powering the board through the barrel plug connector(J29) the user should NOT apply power to the screw terminal (J34).

2.3.3 Screw Terminal External Power Supply

The screw terminal connector (J34) will power the Automotive Networking Development Board. A jumper must be placed onto J28 (pins 2 and 3) to connect the output from the switching power supply circuit to 5V. When power is connected to J34, the power LED D9 or D10 will always be ON to indicate that +3.3V or +5V is available to the PIM module header on the board. To set the voltage delivered to the microcontroller on the PIM, switch S6 will need to be set to 3.3V or 5V, based on the user's requirements. The supported external power range applied to the screw terminal is 7V to 30V.

Note: When powering the board through the screw terminal (J34), the user should NOT apply power to the barrel plug connector(J29).

2.4 ON-BOARD JUMPER CONFIGURATIONS

2.4.1 I²C

Most processor PIM modules bring out a I²C connections on PIM pins 57 (SCL) and 56 (SDA).

JP11 will connect PIM pin 57 to click board headers 1, 2, 3, or 4. By default, the board also supplies a 2k pull-up resistor for the I²C clock.

JP10 will connect PIM pin 56 to click board headers 1, 2, 3, or 4. By default, the board also supplies a 2k pull-up resistor for the I²C data.

FIGURE 2-2: I²C JUMPER BLOCK

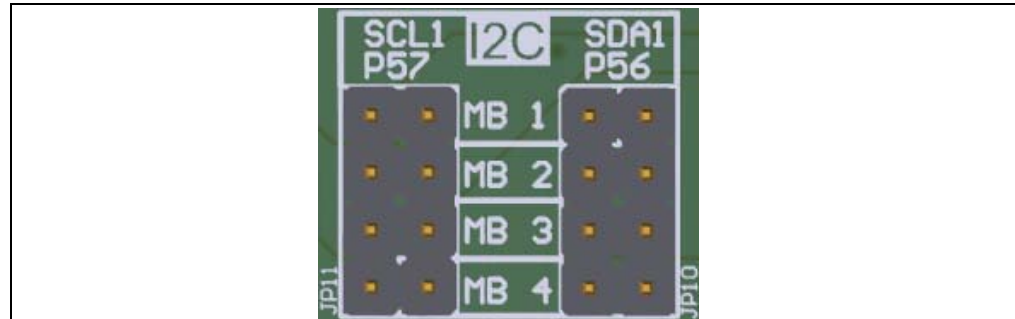

2.4.2 UART

Most processor PIM modules bring out a UART connection on PIM pins P51 (TX) and P52 (RX). PIM modules that have a second UART bring that connection out on P50 (TX) and P49 (RX).

JP4 will connect PIM pin 51 or PIM pin 50 to click board headers 1, 2, 3, or 4.

JP3 will connect PIM pin 52 or PIM pin 49 to click board headers 1, 2, 3, or 4.

FIGURE 2-3: UART JUMPER BLOCK

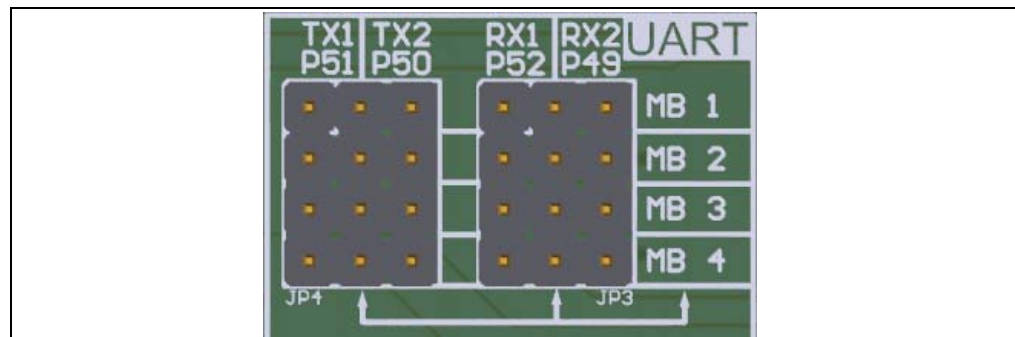

2.4.3 SPI

Most processor PIM modules bring out a SPI connection on PIM pins 55 (SCLK), 53 (MOSI), and 54 (MISO). PIM modules that have a second SPI bring that connection out on PIM pins 10 (SCLK), 12 (MOSI), and 11 (MISO).

JP5 will connect PIM pin 55 or PIM pin 10 to click board headers 1, 2, 3, or 4.

JP7 will connect PIM pin 53 or PIM pin 12 to click board headers 1, 2, 3, or 4.

JP6 will connect PIM pin 54 or PIM pin 11 to click board headers 1, 2, 3, or 4.

FIGURE 2-4: SPI JUMPER BLOCK

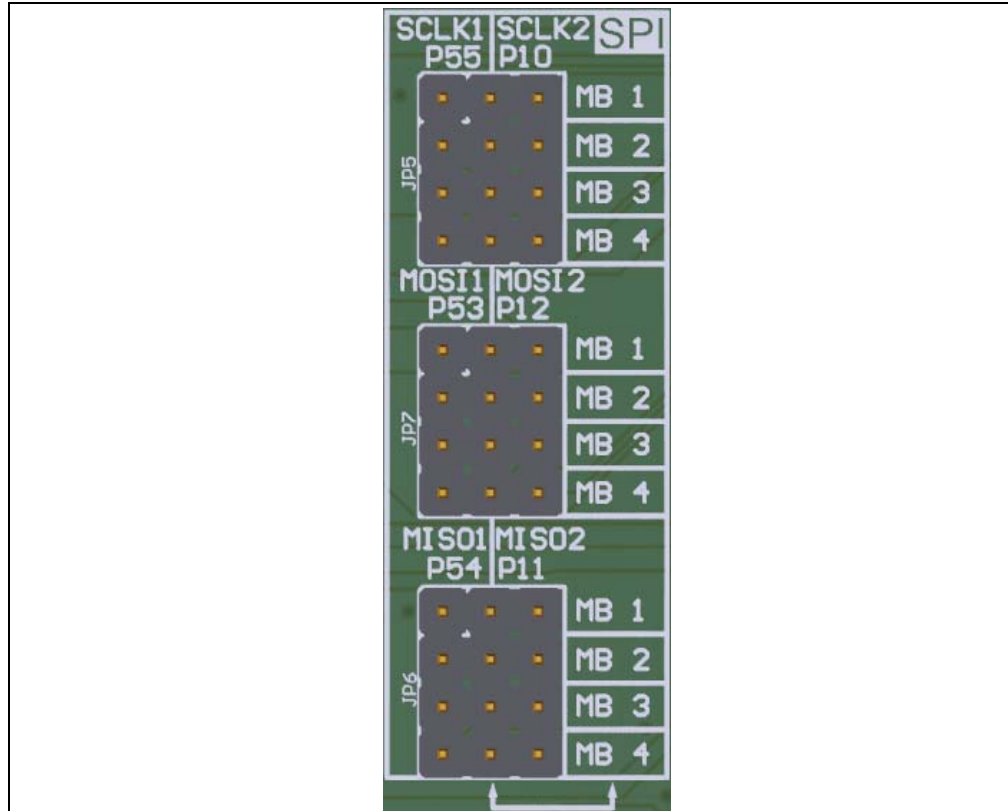

2.4.4 CAN

Most processor PIM modules bring out a CAN connection on PIM pins 88 (TX), 87 (RX). PIM modules that have a second CAN bring that connection out on PIM pins 89 (TX), 90 (RX).

JP9 will connect PIM pin 88 or PIM pin 89 to click board headers 1, 2, 3, or 4.

JP8 will connect PIM pin 87 or PIM pin 90 to click board headers 1, 2, 3, or 4.

FIGURE 2-5: CAN JUMPER BLOCK

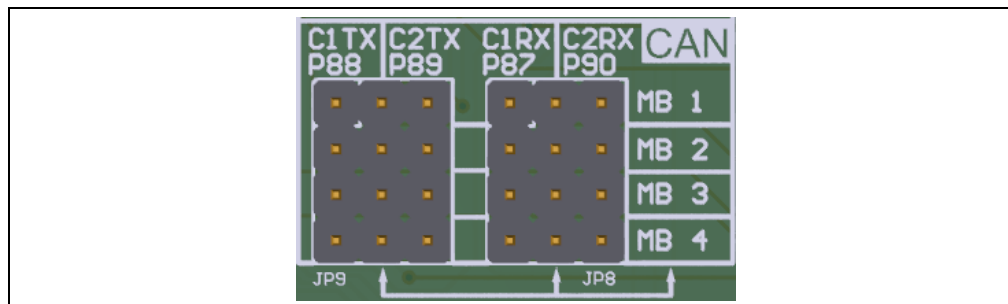

2.4.5 mikroBUS™ Headers

There are four mikroBUS™ headers on the Automotive Networking Development Board and all of them share the SPI, CAN, I²C and UART connections that can be enabled or disabled in the respective jumper blocks. These connections can be configured into the SPI, CAN, I²C and UART jumper blocks.

The rest of the connections on a mikroBUS™ header are not shared. The AN, RST, CS, INT and Pulse-Width Modulator (PWM) connections back to the microcontroller would be unique for each header.

Each header has a breakout jumper connection (J20 for mikroBUS™ header 1). If the user needs to change one of the connections from the microcontroller to the mikroBUS™ header, cut the trace on the back of the board at the breakout connector location. For example, if the user wants to change the AN connection on the mikroBUS™ header 1, cut the AN trace on the back of J20, then wire in another connection from J10/J14.

FIGURE 2-6: TOP OF CLICK

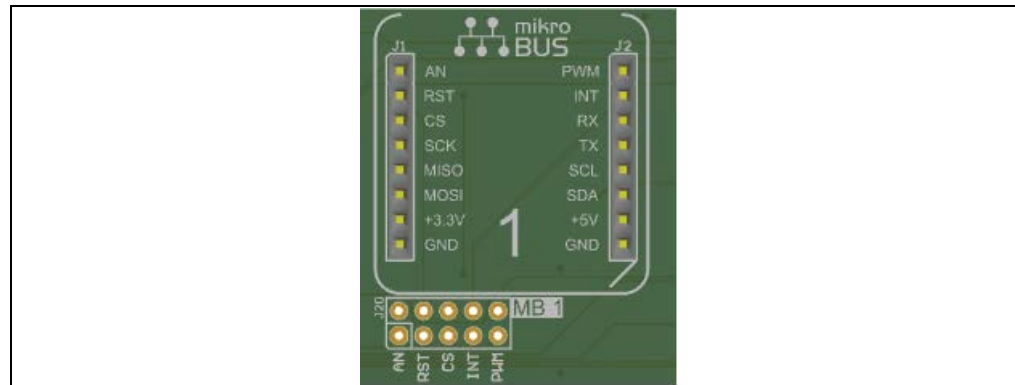
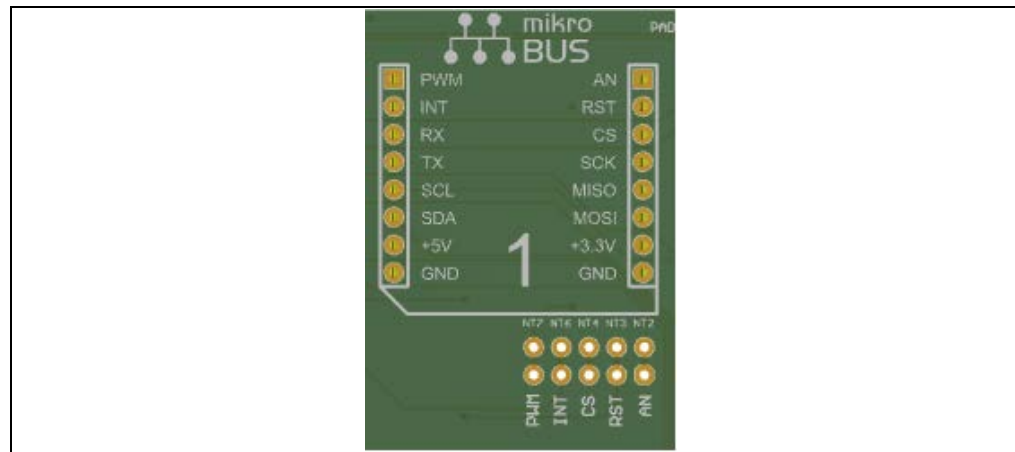

FIGURE 2-7: BOTTOM OF CLICK



2.5 OSCILLATOR CONFIGURATIONS

2.5.1 Default Resonator (MEMS resonator)

The Automotive Networking Development Board uses the DSC1121 which is a Microchip MEMS oscillator as the default clock source into the microcontroller on the PIM header. The DSC1101 on this board has been programmed to generate an output frequency of 8 MHz and is offered in a small 2.5x2.0 mm package.

The DSC1121 is part of a family of high-performance oscillators that utilize a proven silicon MEMS technology that provides excellent jitter performance and stability over a wide range of supply voltages.

MEMS technology eliminates the need for crystals and significantly enhances the product reliability and performance over the wide temperature range. MEMS oscillators have a flat temperature coefficient over the entire range from -55°C to +125°C, as opposed to crystals whose temperature coefficient and stability increases significantly when the temperature rises.

MEMS resonators are very small and are encapsulated which makes them extremely robust against shocks and vibrations. MEMS oscillators are configurable and one-time programmable devices over a wide frequency range of operation. The DSC1121 has an enable pin (pin 1) connected to J13. When a jumper is placed onto J13 this will disable the oscillator output.

2.5.2 Optional Oscillator (Various sources)

To make use of the other oscillator options on the Automotive Networking Development Board, the user will need to disable the DSC1121 Microchip MEMS oscillator by placing a jumper onto J13. The Automotive Networking Development Board provides footprints for the user to populate one of the following primary oscillator source options for the processor PIM: surface mount crystal, through-hole mounted crystal, or a through-hole mounted 4-pin TTL oscillator. The user should only populate one oscillator footprint as the primary source for the processor PIM.

2.6 PROGRAMMING THE BOARD

2.6.1 ICD

An MPLAB[®] programmer or debugger can be connected through the modular connector (JP1) for low-cost debugging.

2.6.2 PICkit™ Programmer connector

Connector J11 provides the footprint for a 6-pin PICkit™ programmer interface.

Chapter 3. Software

3.1 INTRODUCTION

The Automotive Networking Development Board can be used with MPLAB® X Integrated Development Environment (IDE), available free on Microchip's website, www.microchip.com. This software is used for programming and debugging a PIM on the Automotive Networking Development Board.

Note: This kit does **NOT** contain a processor PIM (Plug-in Module).

3.2 SOFTWARE OVERVIEW

The Automotive Networking Development Board supports the use of a low-voltage in-circuit debugger, as well as a low-voltage programmer for all supported devices through MPLAB® X. In-circuit debugging allows the user to run, examine and modify programs for the supported device embedded in the board's hardware. This facilitates the debugging of firmware and hardware concurrently. Use the Automotive Networking Development Board with MPLAB X IDE to run, stop and single-step through programs – breakpoints can be set and the processor can be reset. When the processor stops, the contents of the register are available for examination and modification.

NOTES:

Chapter 4. Troubleshooting Common Problems

4.1 PROGRAMMING ISSUES

4.1.1 Programming of the PIM Module has Failed

4.1.1.1 CAUSE 1

The orientation of the PIM on the Automotive Networking Development Board is incorrect.

4.1.1.2 SOLUTION 1

Adjust the orientation of the PIM on the Automotive Networking Development Board. For additional details on these features, refer to [Section 2.2.1 “Processor Support”](#).

4.1.1.3 CAUSE 2

The voltage supplied to the microcontroller on the PIM is incorrect.

4.1.1.4 SOLUTION 2

Confirm the jumper on J28 is populated correctly and adjust switch S6 to correctly meet the user's requirements of voltage level supplied to the micro on the PIM board (3.3V or 5V).

For additional details on these features, refer to [Section 1.4 “Using the Automotive Networking Development Board for the First Time”](#).

NOTES:

Appendix A. Schematics

A.1 INTRODUCTION

This section provides detailed technical information on the Automotive Networking Development Board.

A.2 DEVELOPMENT BOARD BLOCK DIAGRAM

FIGURE A-1: DEVELOPMENT BOARD BLOCK DIAGRAM

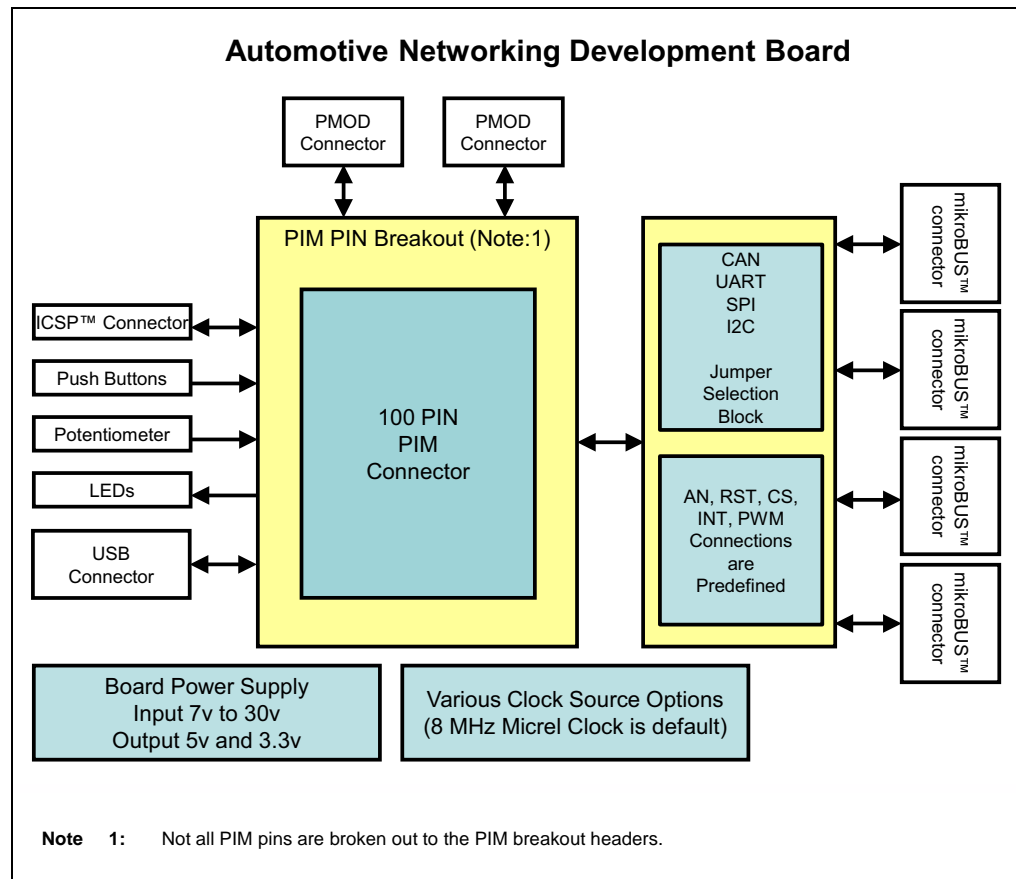

A.3 DEVELOPMENT BOARD SCHEMATICS

FIGURE A-2: mikroBUS™ INTERFACE

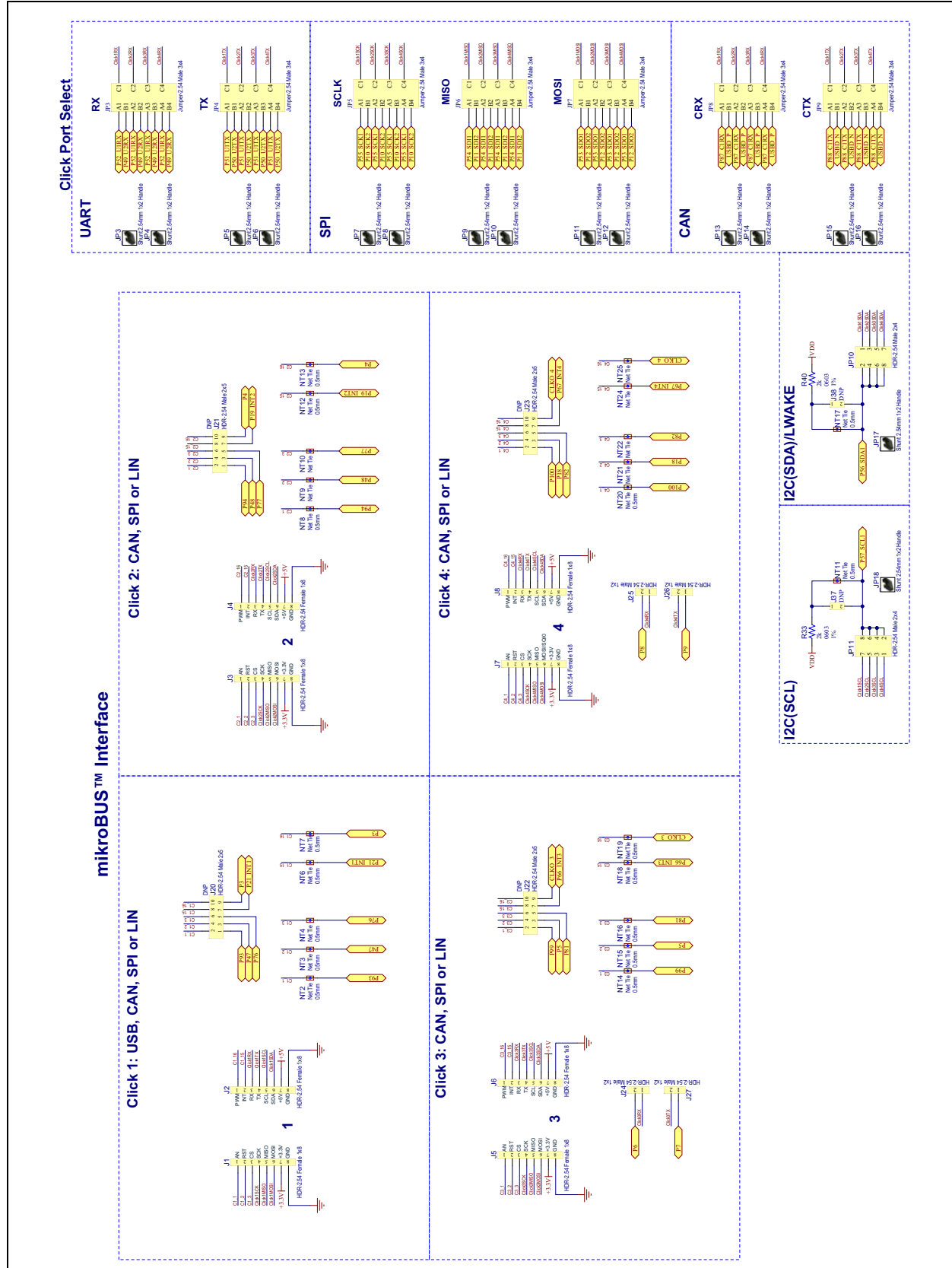

FIGURE A-3: PIM CONNECTION AND BREAKOUT

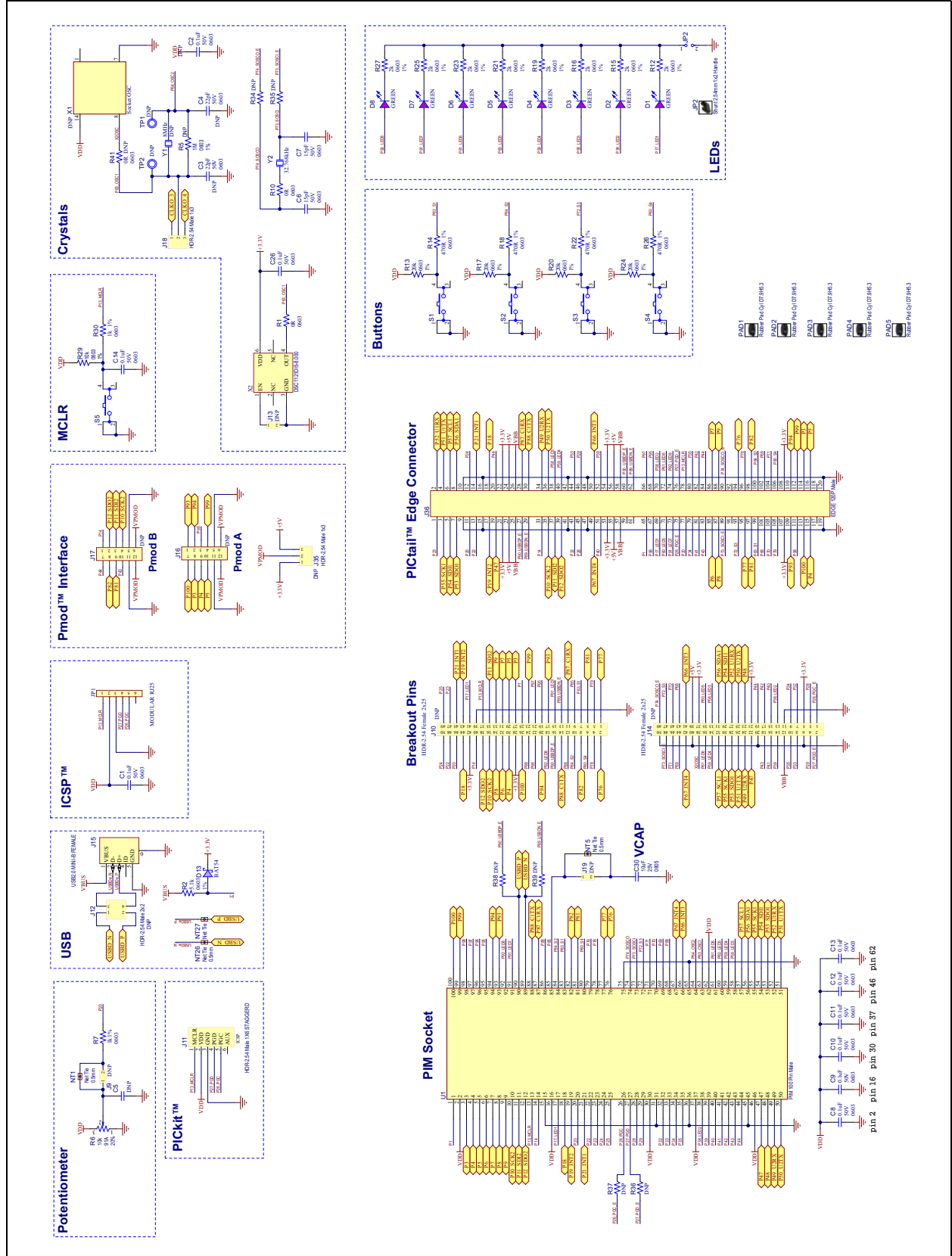
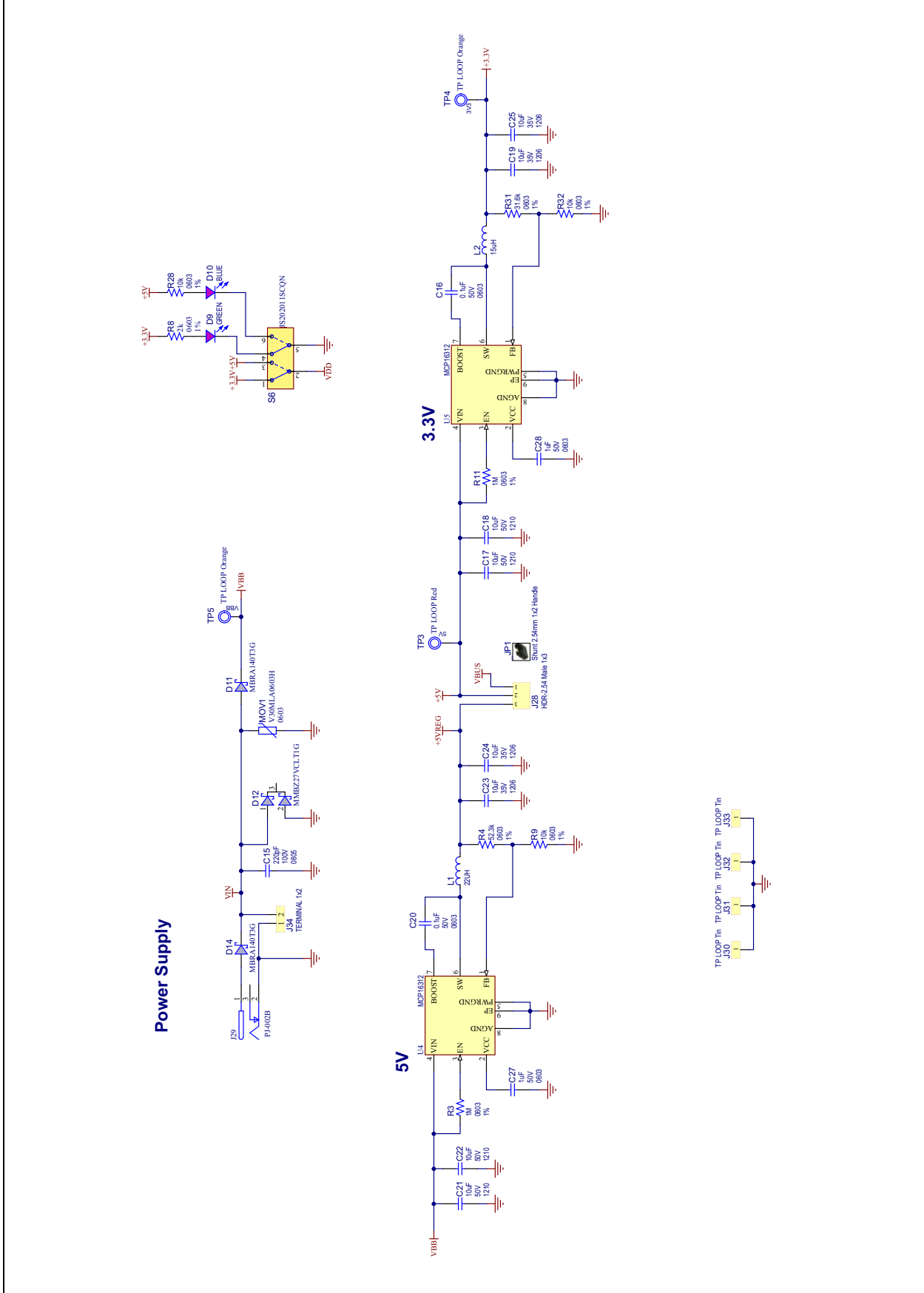

FIGURE A-4: POWER SUPPLY





MICROCHIP

Worldwide Sales and Service

AMERICAS

Corporate Office

2355 West Chandler Blvd.
Chandler, AZ 85224-6199

Tel: 480-792-7200

Fax: 480-792-7277

Technical Support:

[http://www.microchip.com/
support](http://www.microchip.com/support)

Web Address:

www.microchip.com

Atlanta

Duluth, GA

Tel: 678-957-9614

Fax: 678-957-1455

Austin, TX

Tel: 512-257-3370

Boston

Westborough, MA

Tel: 774-760-0087

Fax: 774-760-0088

Chicago

Itasca, IL

Tel: 630-285-0071

Fax: 630-285-0075

Cleveland

Independence, OH

Tel: 216-447-0464

Fax: 216-447-0643

Dallas

Addison, TX

Tel: 972-818-7423

Fax: 972-818-2924

Detroit

Novi, MI

Tel: 248-848-4000

Houston, TX

Tel: 281-894-5983

Indianapolis

Noblesville, IN

Tel: 317-773-8323

Fax: 317-773-5453

Los Angeles

Mission Viejo, CA

Tel: 949-462-9523

Fax: 949-462-9608

New York, NY

Tel: 631-435-6000

San Jose, CA

Tel: 408-735-9110

Canada - Toronto

Tel: 905-695-1980

Fax: 905-695-2078

ASIA/PACIFIC

Asia Pacific Office

Suites 3707-14, 37th Floor
Tower 6, The Gateway
Harbour City, Kowloon

Hong Kong

Tel: 852-2943-5100

Fax: 852-2401-3431

Australia - Sydney

Tel: 61-2-9868-6733

Fax: 61-2-9868-6755

China - Beijing

Tel: 86-10-8569-7000

Fax: 86-10-8528-2104

China - Chengdu

Tel: 86-28-8665-5511

Fax: 86-28-8665-7889

China - Chongqing

Tel: 86-23-8980-9588

Fax: 86-23-8980-9500

China - Dongguan

Tel: 86-769-8702-9880

China - Guangzhou

Tel: 86-20-8755-8029

China - Hangzhou

Tel: 86-571-8792-8115

Fax: 86-571-8792-8116

China - Hong Kong SAR

Tel: 852-2943-5100

Fax: 852-2401-3431

China - Nanjing

Tel: 86-25-8473-2460

Fax: 86-25-8473-2470

China - Qingdao

Tel: 86-532-8502-7355

Fax: 86-532-8502-7205

China - Shanghai

Tel: 86-21-5407-5533

Fax: 86-21-5407-5066

China - Shenyang

Tel: 86-24-2334-2829

Fax: 86-24-2334-2393

China - Shenzhen

Tel: 86-755-8864-2200

Fax: 86-755-8203-1760

China - Wuhan

Tel: 86-27-5980-5300

Fax: 86-27-5980-5118

China - Xian

Tel: 86-29-8833-7252

Fax: 86-29-8833-7256

ASIA/PACIFIC

China - Xiamen

Tel: 86-592-2388138

Fax: 86-592-2388130

China - Zhuhai

Tel: 86-756-3210040

Fax: 86-756-3210049

India - Bangalore

Tel: 91-80-3090-4444

Fax: 91-80-3090-4123

India - New Delhi

Tel: 91-11-4160-8631

Fax: 91-11-4160-8632

India - Pune

Tel: 91-20-3019-1500

Japan - Osaka

Tel: 81-6-6152-7160

Fax: 81-6-6152-9310

Japan - Tokyo

Tel: 81-3-6880-3770

Fax: 81-3-6880-3771

Korea - Daegu

Tel: 82-53-744-4301

Fax: 82-53-744-4302

Korea - Seoul

Tel: 82-2-554-7200

Fax: 82-2-558-5932 or

82-2-558-5934

Malaysia - Kuala Lumpur

Tel: 60-3-6201-9857

Fax: 60-3-6201-9859

Malaysia - Penang

Tel: 60-4-227-8870

Fax: 60-4-227-4068

Philippines - Manila

Tel: 63-2-634-9065

Fax: 63-2-634-9069

Singapore

Tel: 65-6334-8870

Fax: 65-6334-8850

Taiwan - Hsin Chu

Tel: 886-3-5778-366

Fax: 886-3-5770-955

Taiwan - Kaohsiung

Tel: 886-7-213-7828

Taiwan - Taipei

Tel: 886-2-2508-8600

Fax: 886-2-2508-0102

Thailand - Bangkok

Tel: 66-2-694-1351

Fax: 66-2-694-1350

EUROPE

Austria - Wels

Tel: 43-7242-2244-39

Fax: 43-7242-2244-393

Denmark - Copenhagen

Tel: 45-4450-2828

Fax: 45-4485-2829

France - Paris

Tel: 33-1-69-53-63-20

Fax: 33-1-69-30-90-79

Germany - Dusseldorf

Tel: 49-2129-3766400

Germany - Karlsruhe

Tel: 49-721-625370

Germany - Munich

Tel: 49-89-627-144-0

Fax: 49-89-627-144-44

Italy - Milan

Tel: 39-0331-742611

Fax: 39-0331-466781

Italy - Venice

Tel: 39-049-7625286

Netherlands - Drunen

Tel: 31-416-690399

Fax: 31-416-690340

Poland - Warsaw

Tel: 48-22-3325737

Spain - Madrid

Tel: 34-91-708-08-90

Fax: 34-91-708-08-91

Sweden - Stockholm

Tel: 46-8-5090-4654

UK - Wokingham

Tel: 44-118-921-5800

Fax: 44-118-921-5820

06/23/16