

QB50 Project, TR01/TR02 BeEagleSAT and HavelSat

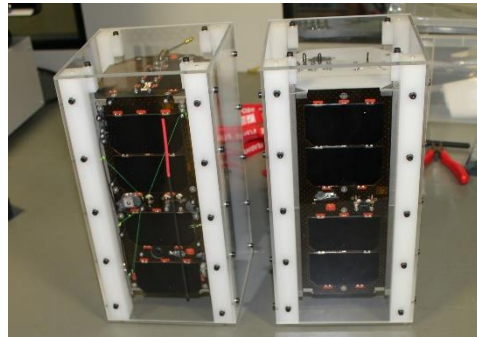
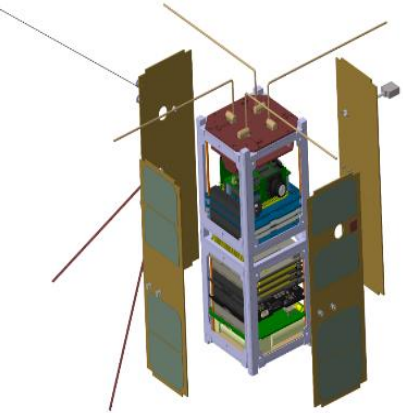

Istanbul Technical University, Faculty of Aeronautics and Astronautics,
Space Systems Design and Test Laboratory
Istanbul, Turkey

A.R Aslan¹, B. Karabulut¹, M.Ş. Uludağ¹, M.E. Bas², E. Yakut²,
M.D. Aksulu², S. Türkoğlu¹, M. Karataş¹, C. Cenik¹, M. Suer², İ.
Arslan³, K. Arslankoz³

1 Space Systems Design and Test Lab, Istanbul Technical
University, Istanbul, Turkey

2 Gumush Uzay Ltd., Istanbul, Turkey

3 HAVELSAN Co., Ankara, Turkey

Also with contributions from

AIRFORCE ACADEMY

SABANCI UNIVERSITY

Ertek Co.



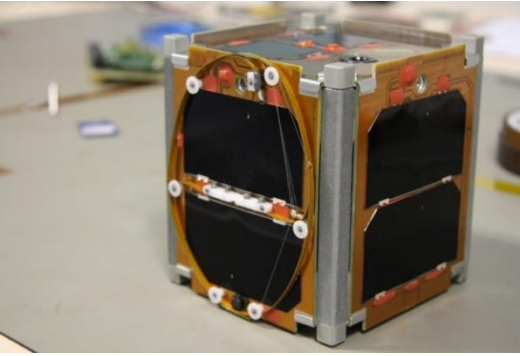

ITUPSAT1: 2009

TURKSAT 3USAT: 2013

BEEAGLESAT and HAVELSAT: 2016-17

UBAKUSAT: 2017

ASELSAT: 2018

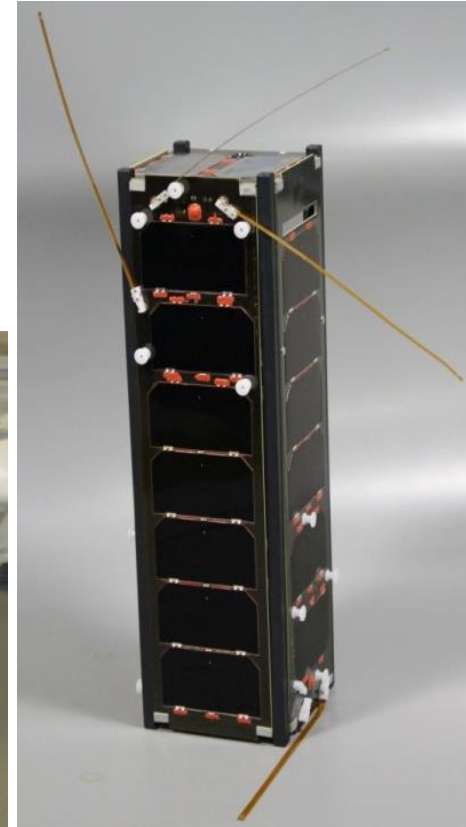
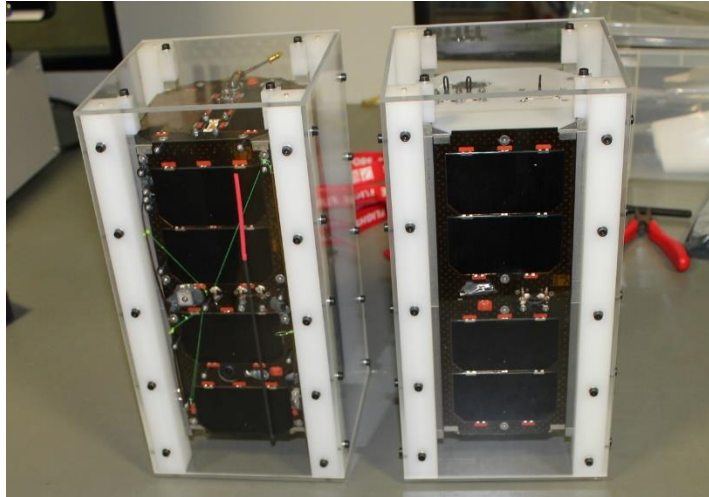
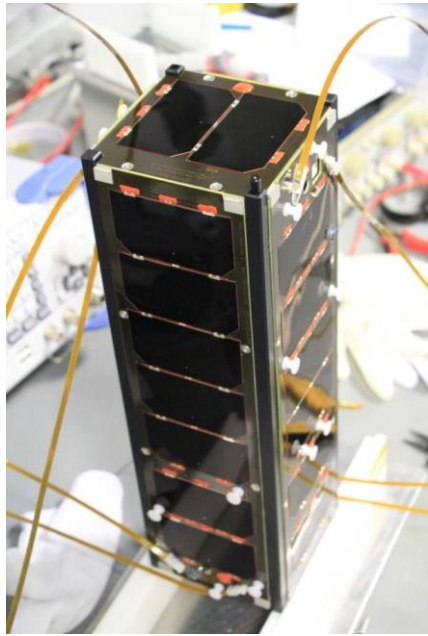



BeEagleSAT and HavelSat

- BeEagleSAT is a joint project of Istanbul Technical University, Turkish Air Force Academy, and Sabanci University (UTEB MEMBERS) along with SMEs and Aerospace Industry HAVELSAN
- HavelSat is developed by ITU and Havelsan Co

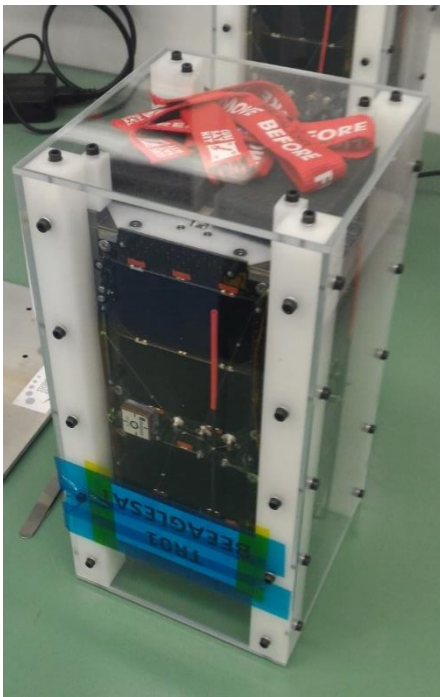

Asırlardır Çoğuş

51

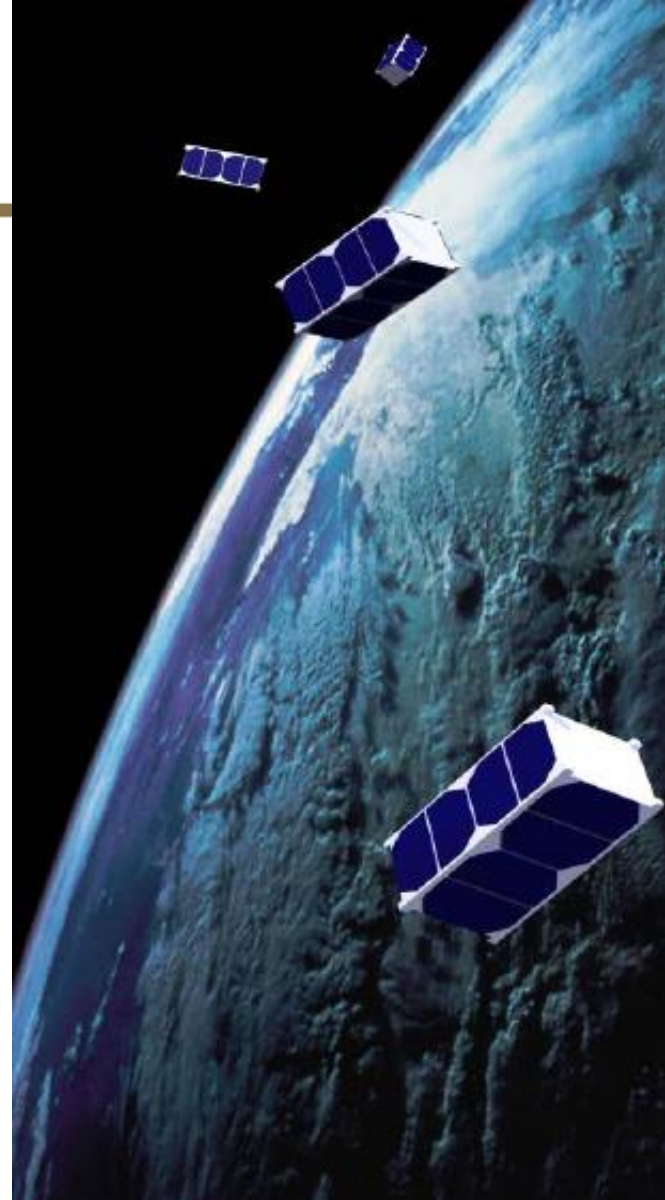

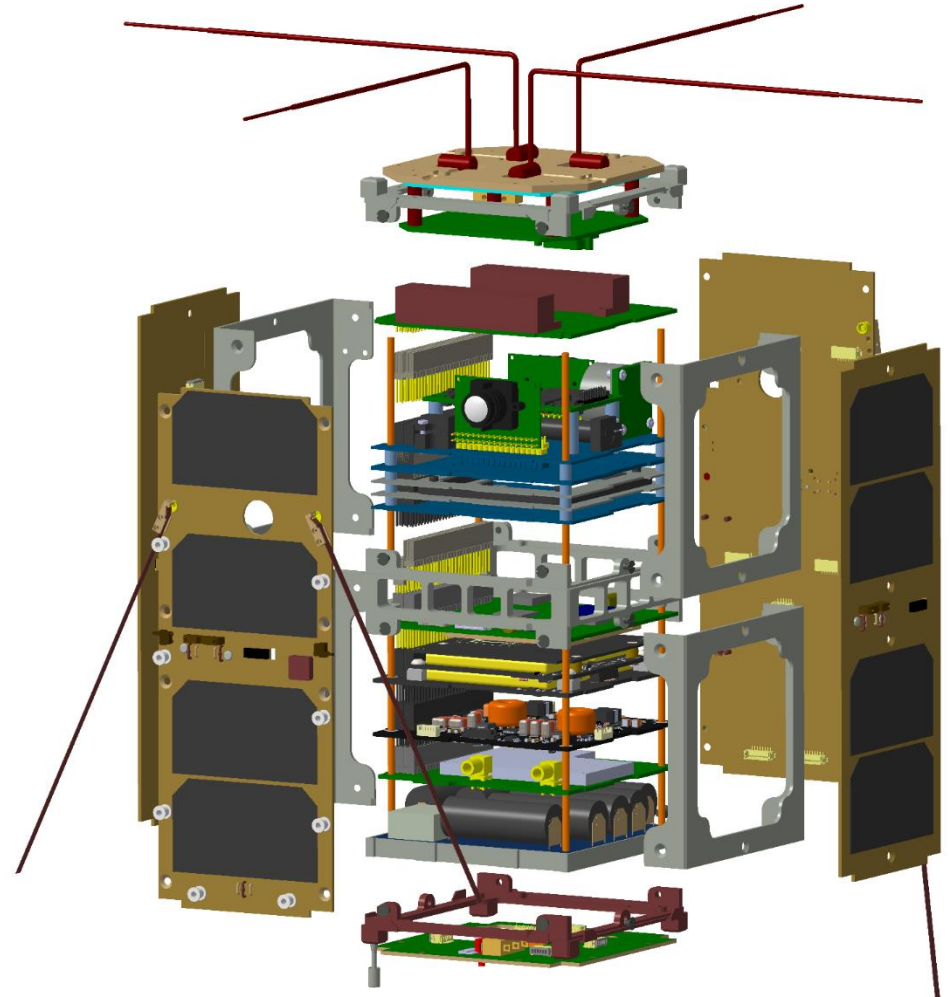
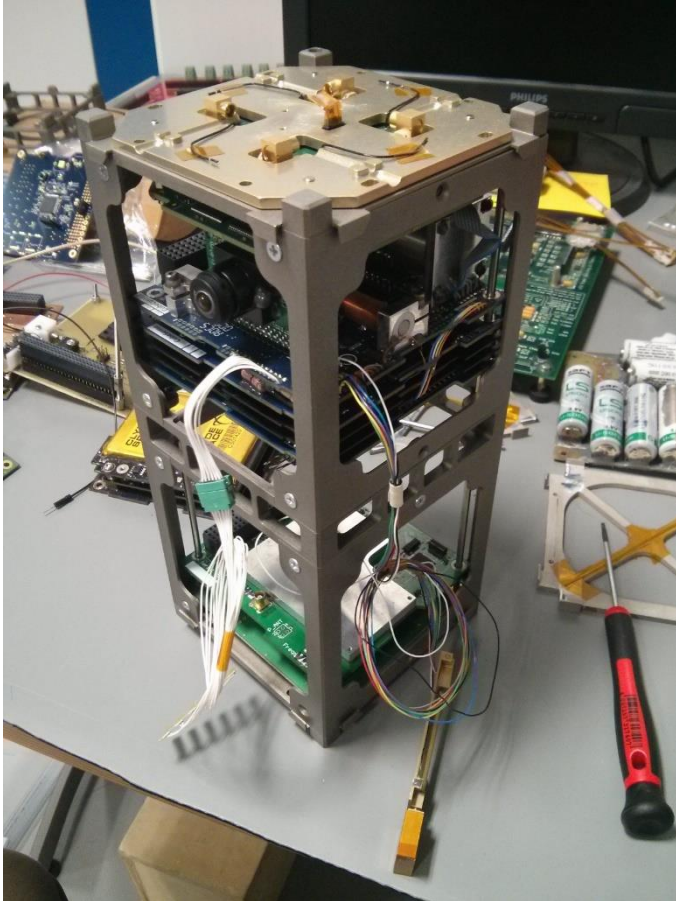

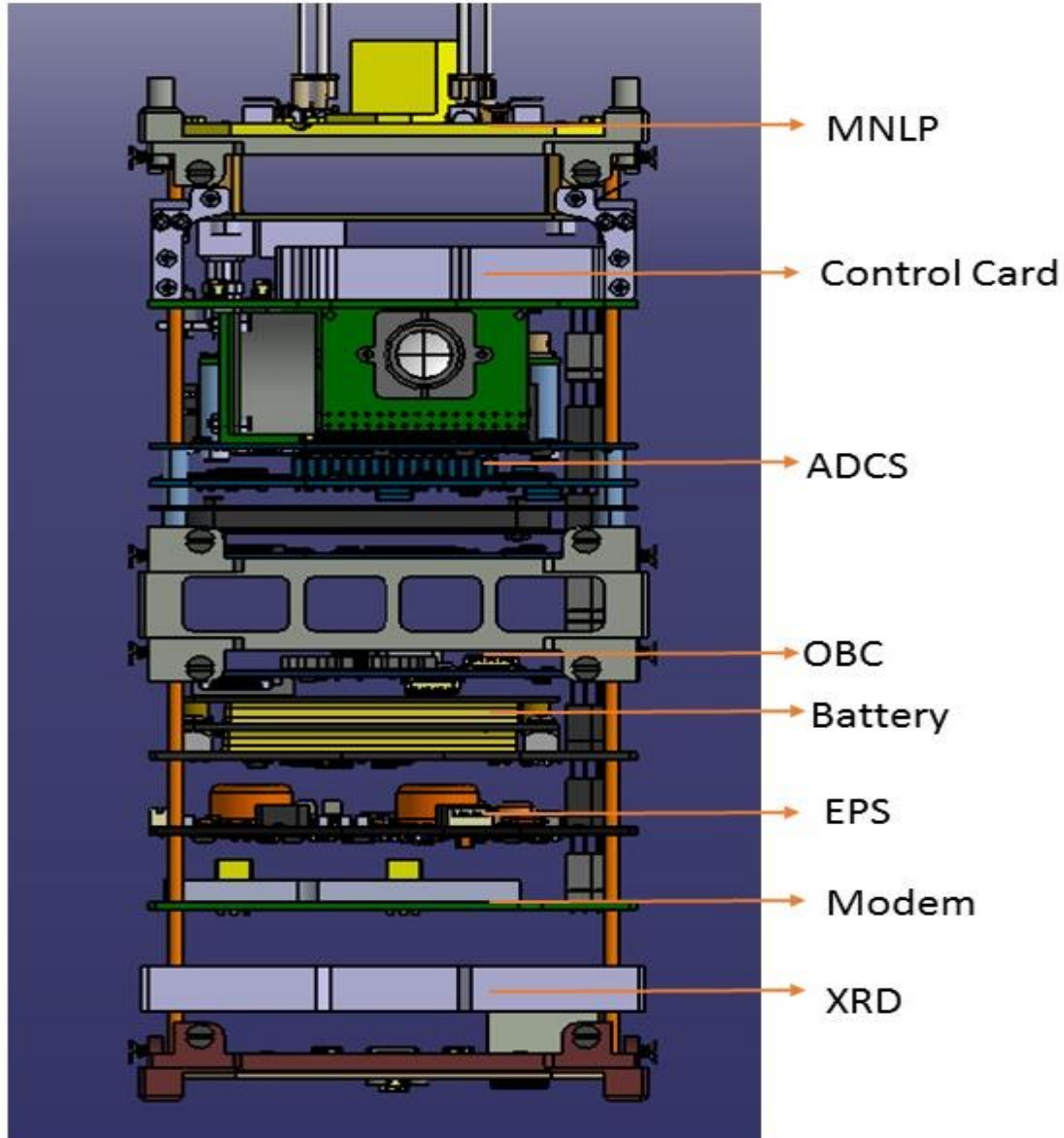

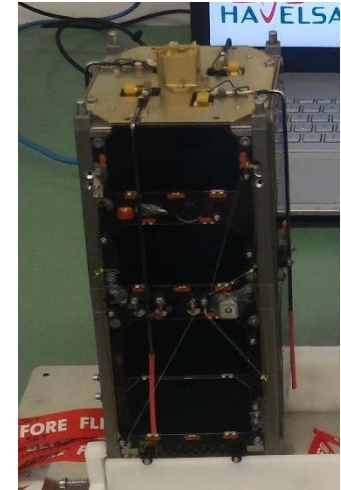
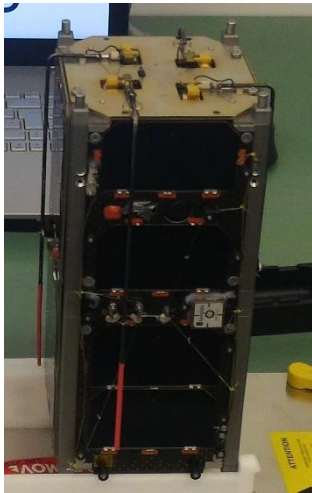
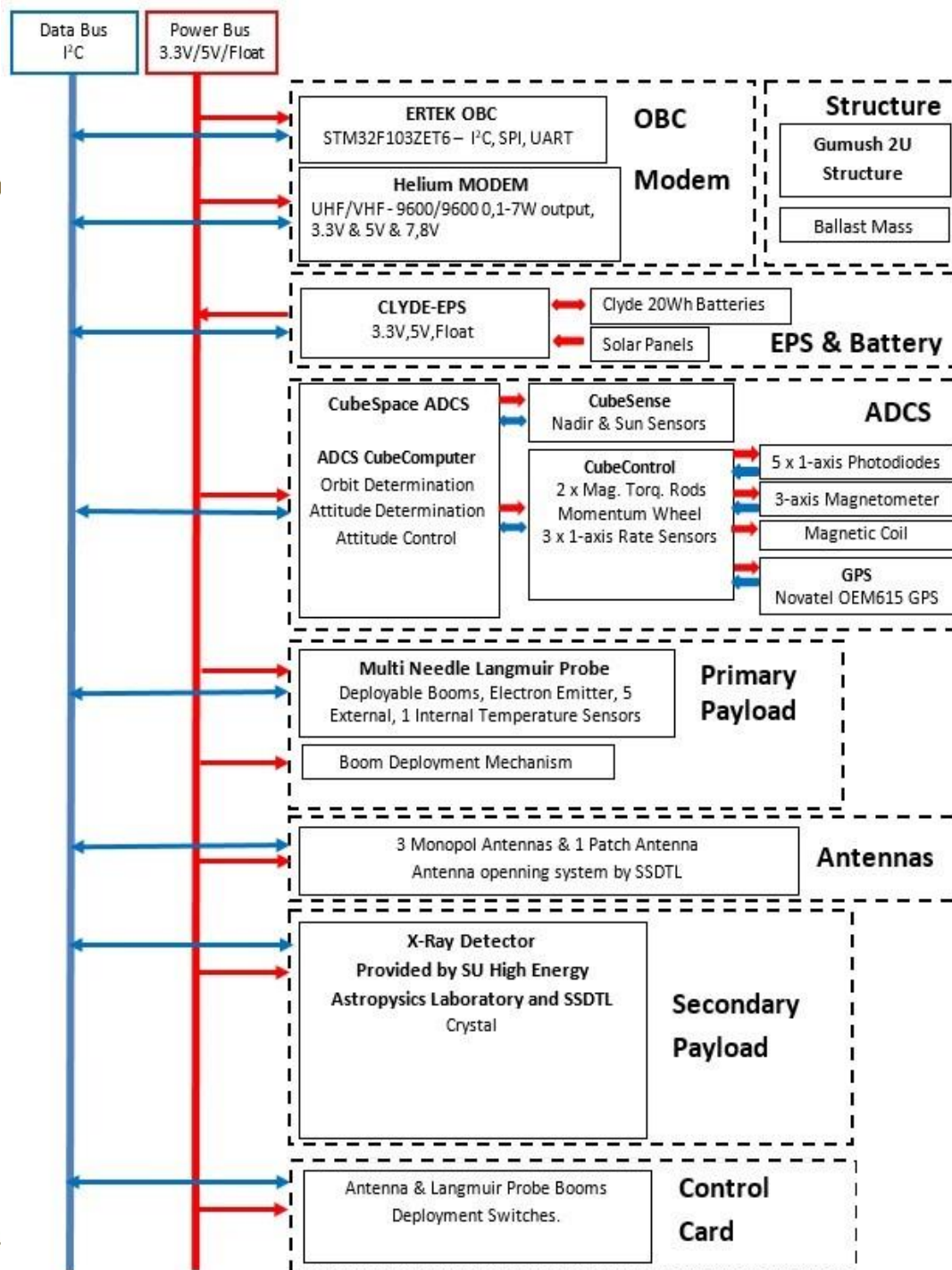

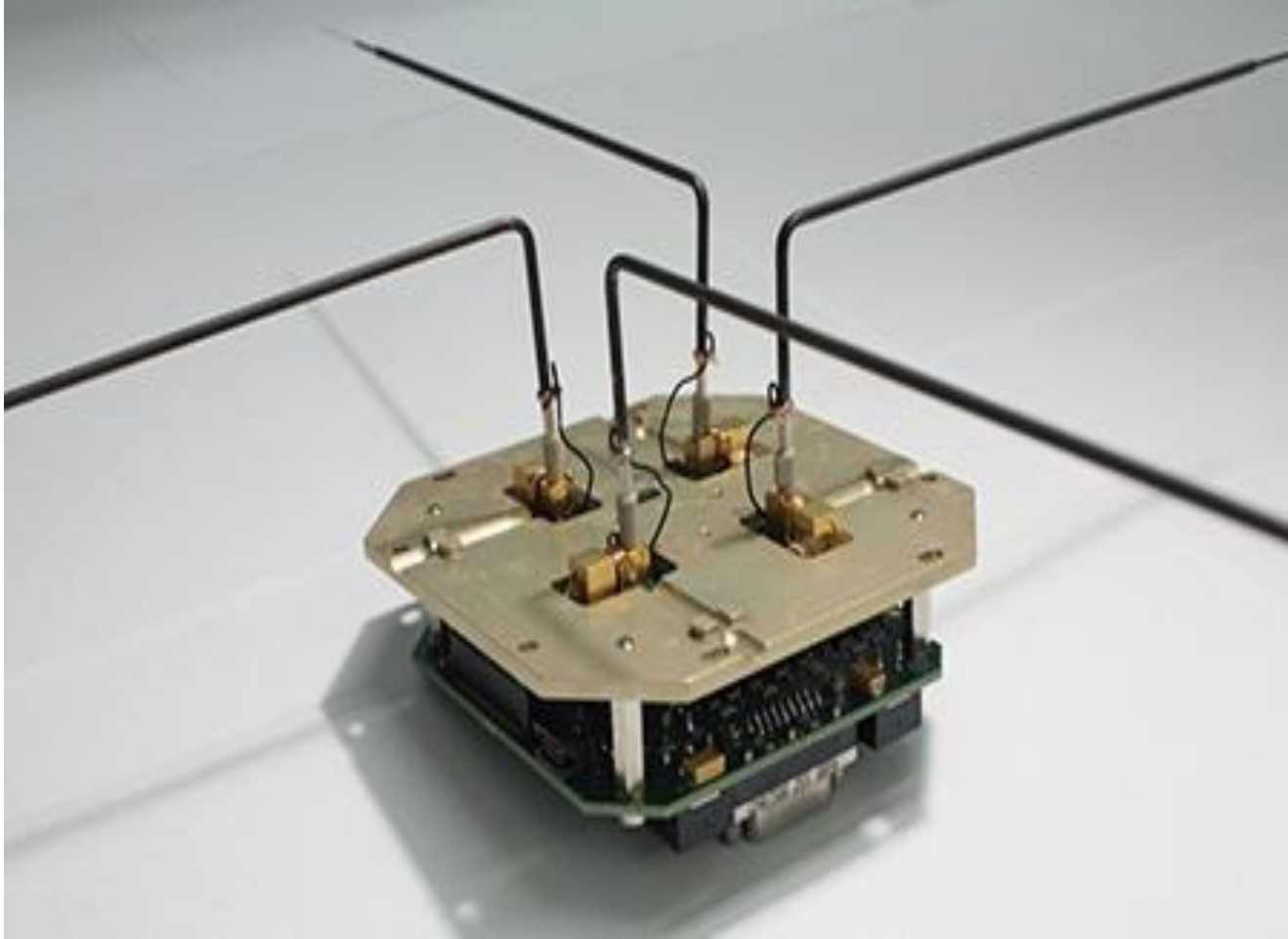

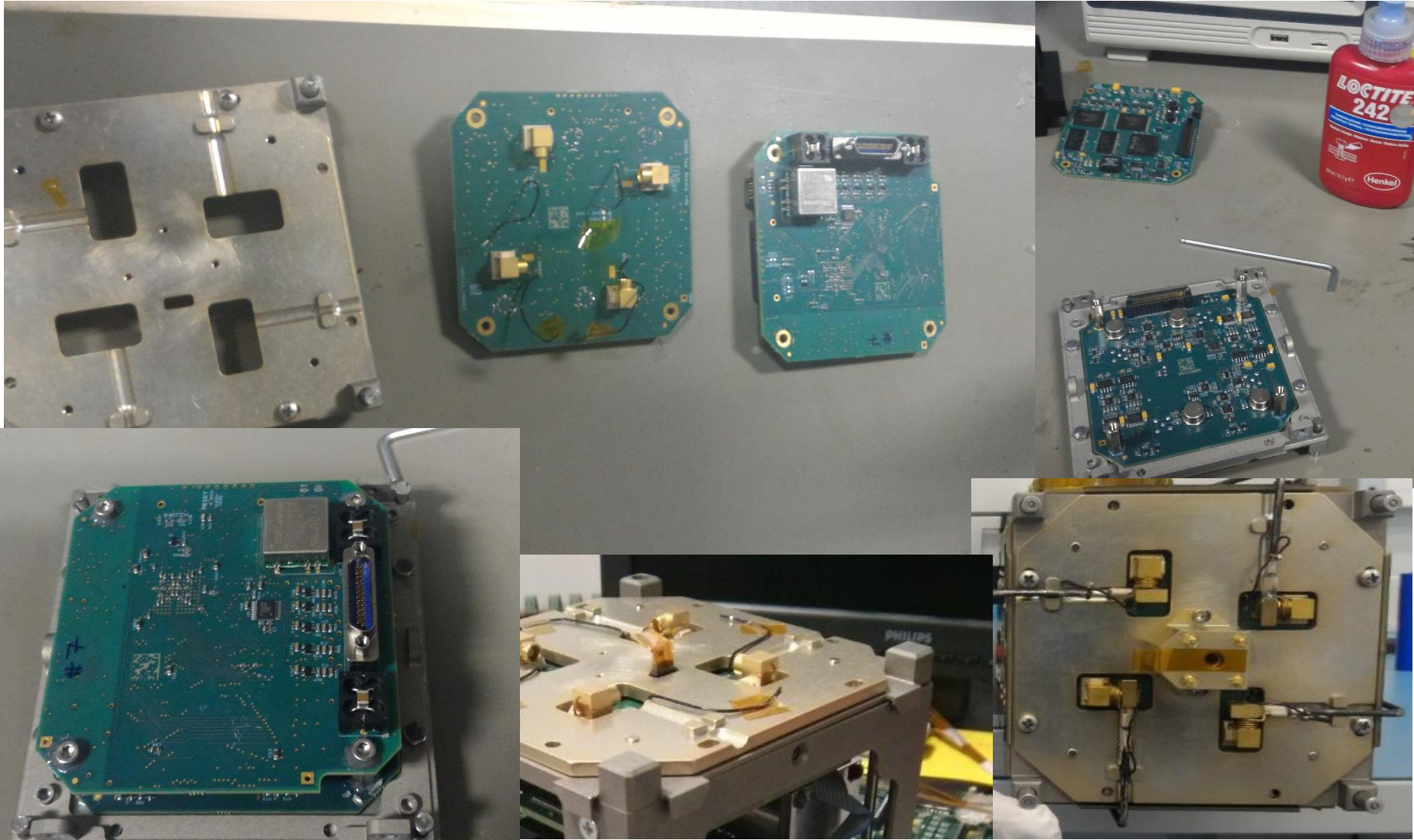

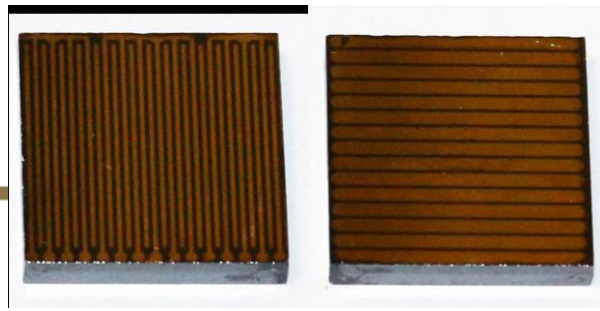

XRD

- The BeeagleSat also houses a secondary science unit, namely X-Ray (CdZnTe) detector developed to measure the high energy X-ray background at a range of altitudes at low Earth orbit of the

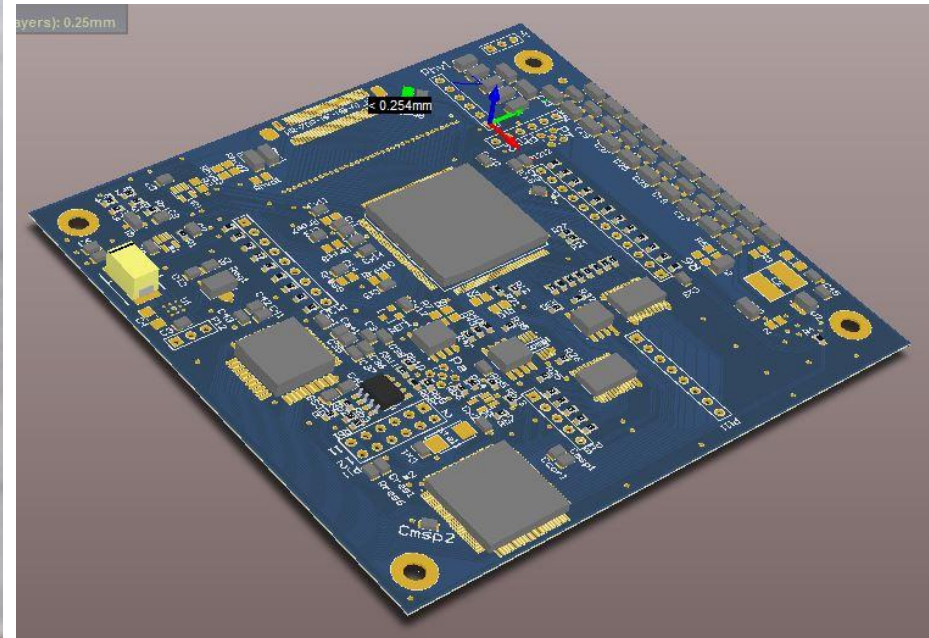

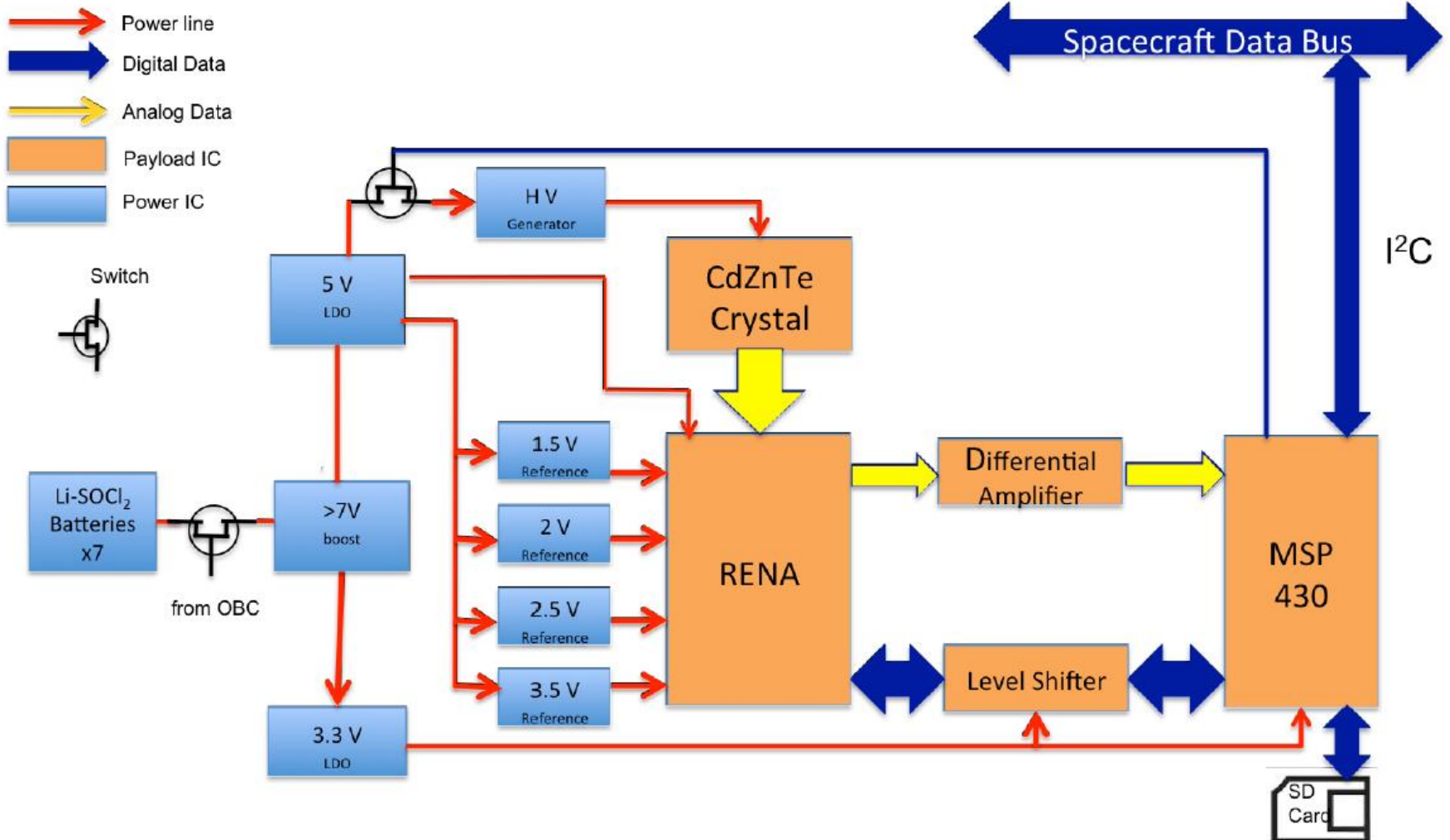

Subsystem	Mass [kg]
Extra Mass	0,1947
mNLP	0,1905
Control Card	0,0595
ADCS with GPS	0,3680
OBC-Beacon	0,0565
Battery	0,1950
EPS	0,0915
Modem	0,0860
Structure	0,2662
Solar Panel 1 (Nadir)	0,1159
Solar Panel 2 (PC104 - Bus)	0,0876
Solar Panel 3 (Zenith)	0,1167
Solar Panel 4 (-)	0,0876
Solar Panel 5 (Bottom)	0,0523
ExtraPC104BusConnectors	0,0417
Cables	0,1500
XRD	0,0980
Total	2,2577

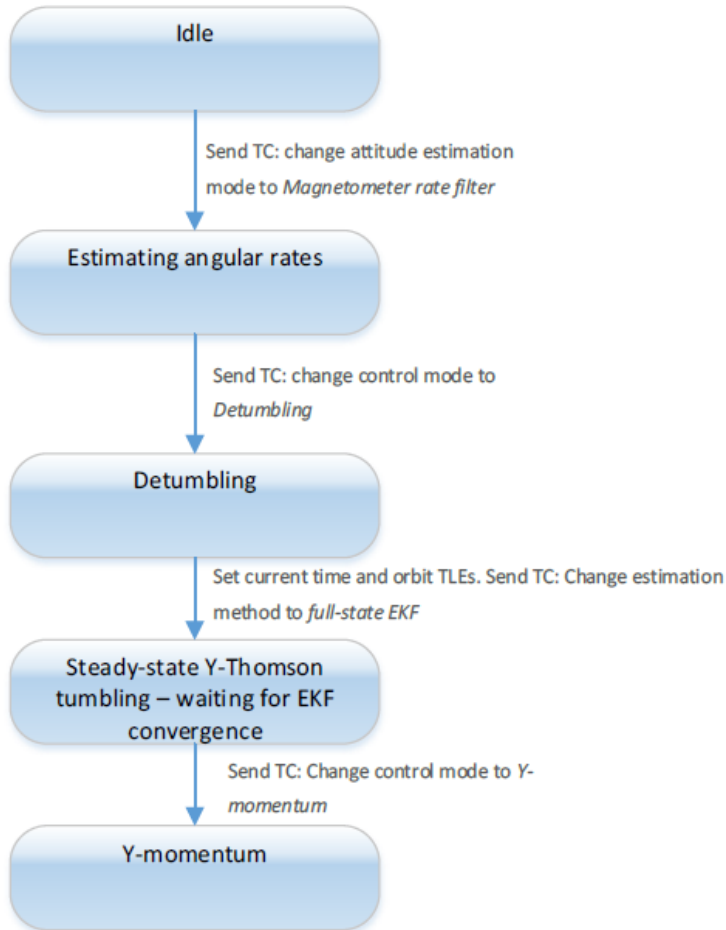

- In house algorithm developed to make ADCS mode transitions autonomous but can be made manual too.

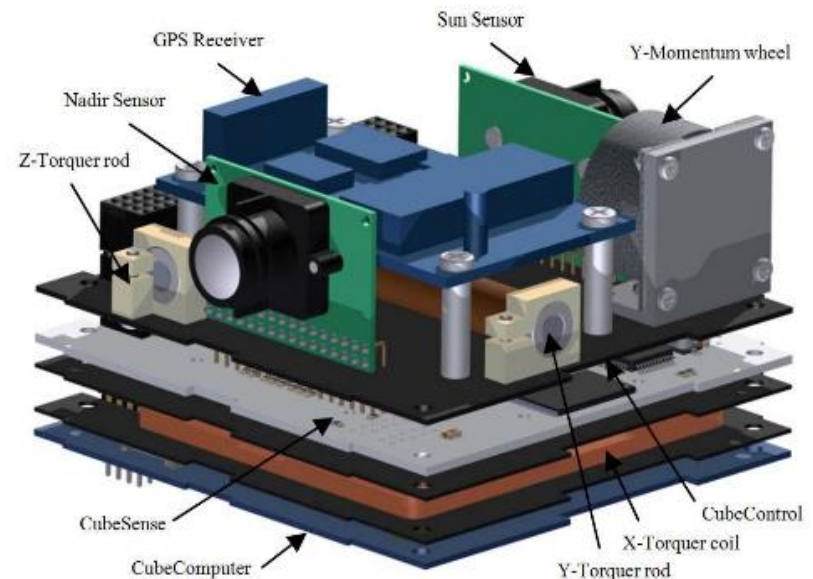

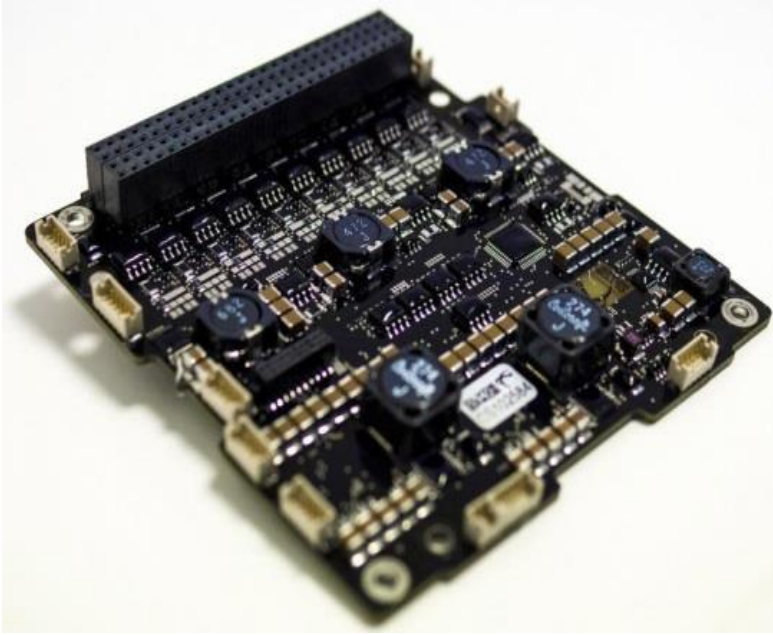

	Power Req (w)	Duty Cycle (%)	Power Consumed (W)
mNLP	1,18	x	0,5
ADCS	0,65	100	0,65
GPS	1	0,0015	0,000015
OBC	0,25	100	0,25
XRAY	0,8	X	
Helium (rX)	0,2	100	0,2
Helium (tX)	3,5	0,7	0,0245
Beacon	1,5	50	0,75
EPS	0,1	100	0,1
Total Power Consumed			2,47
Power Generated			2,62
Margin (%)			5,55

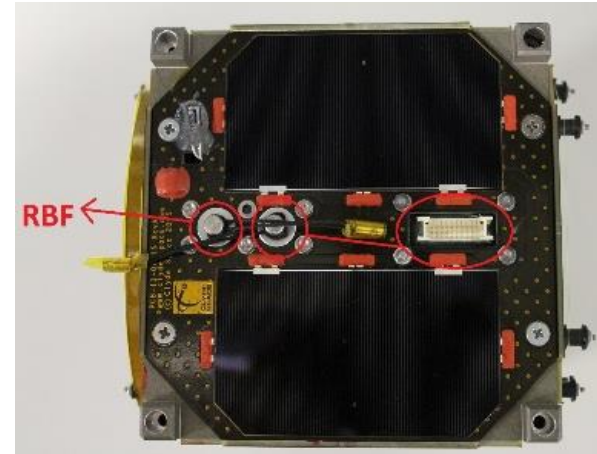
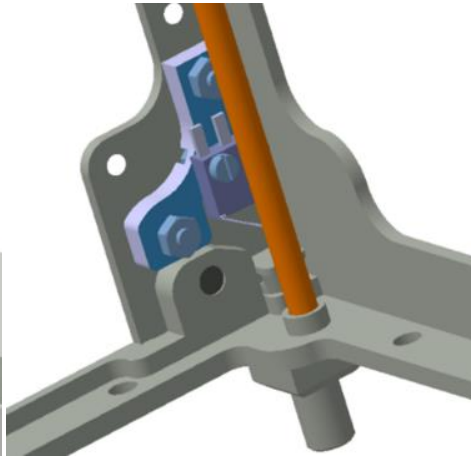
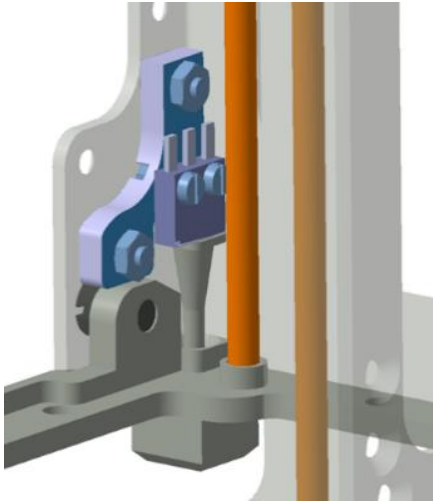
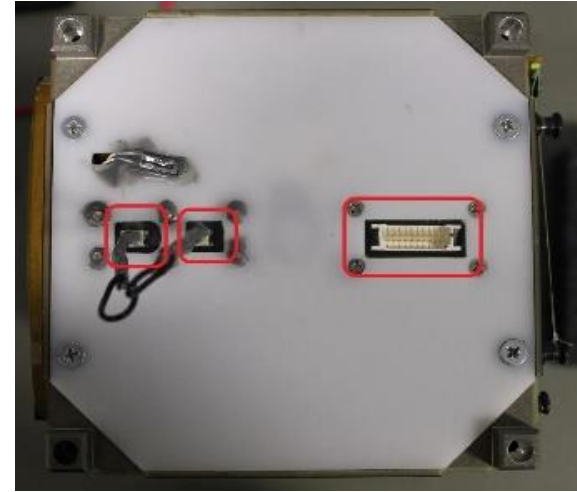
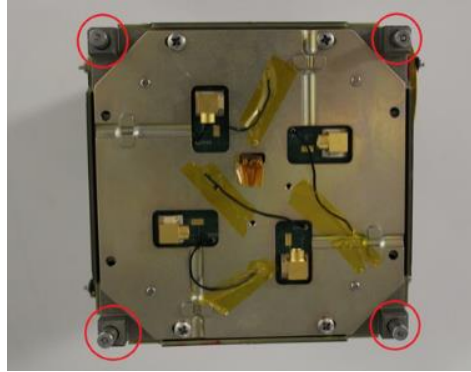

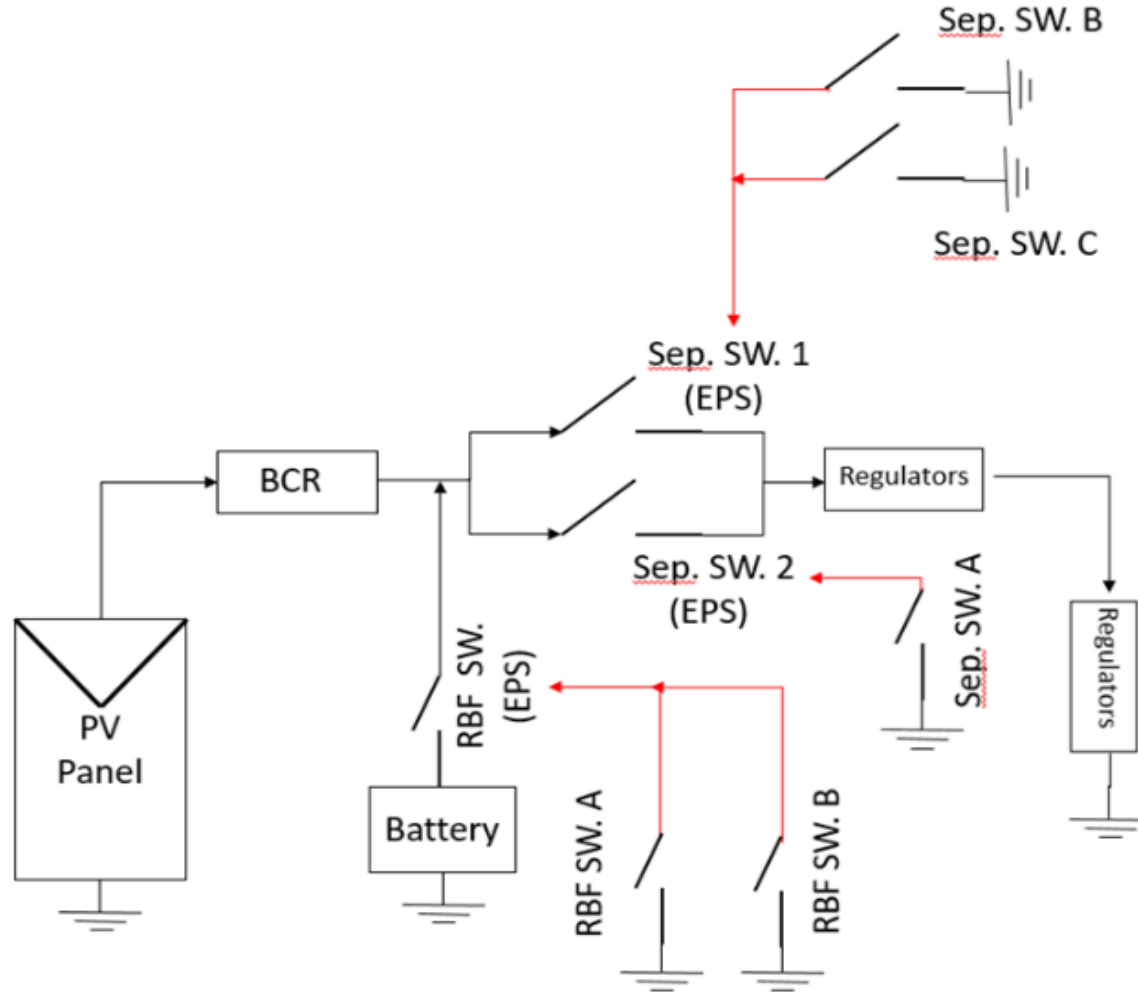

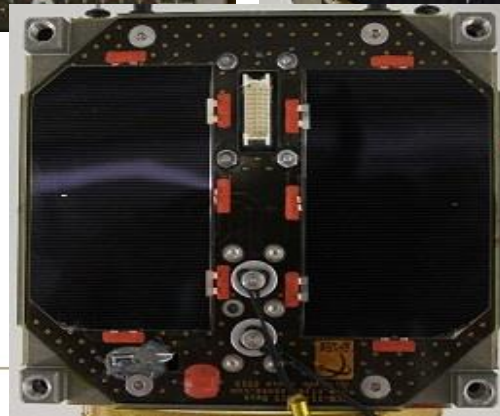
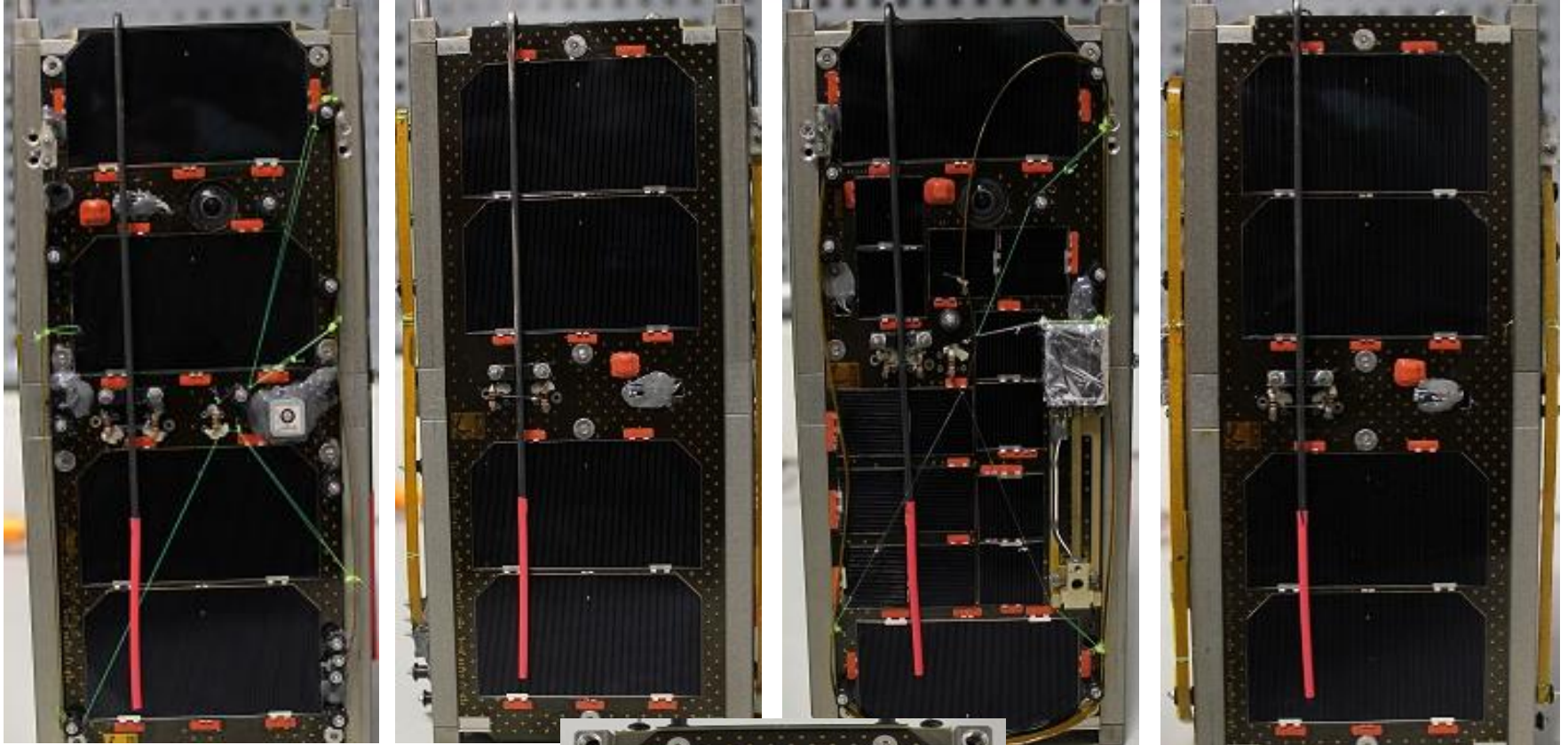

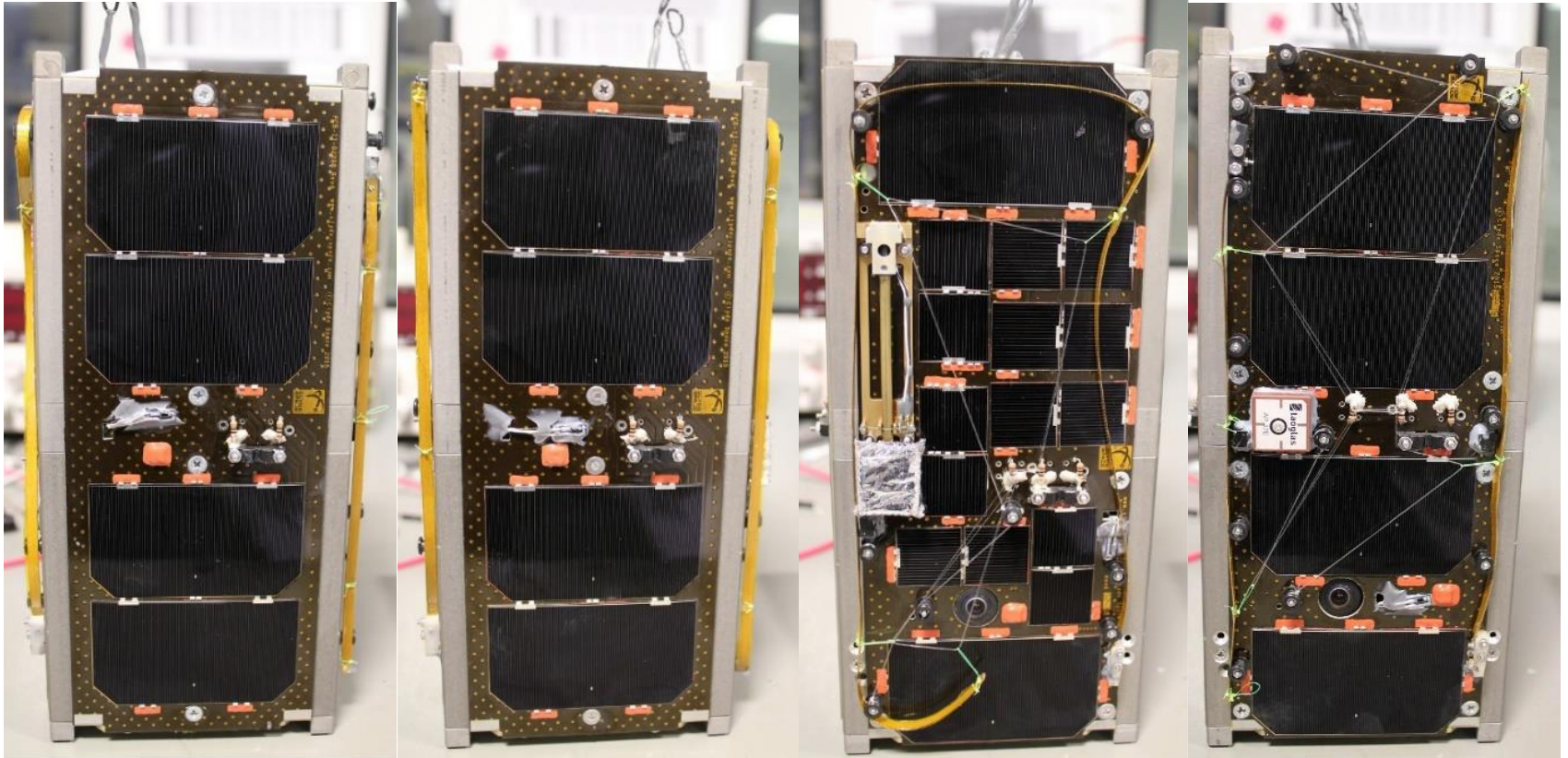

Transceiver Specifications	
Manufacturer	Astrodev
Model	Helium 100
Maximum power output to antenna [W]	1 Watt
Maximum transmitter field strength (volts/meter);	7.02 V/m
Rx Frequency Range [MHz]	120 - 150
Tx Frequency Range [MHz]	430 - 450
Circuit Loss: [dB]	0.5
Antenna Manufacturer	Istanbul Technical University
Antenna Type:	Monopole
Antenna Axial Ratio: [dB]	0
Antenna location	Side +Y
Emission Bandwidth:	-3 dB [20 kHz]
Data Rate	9600 kbps
Modulation Scheme:	GMSK

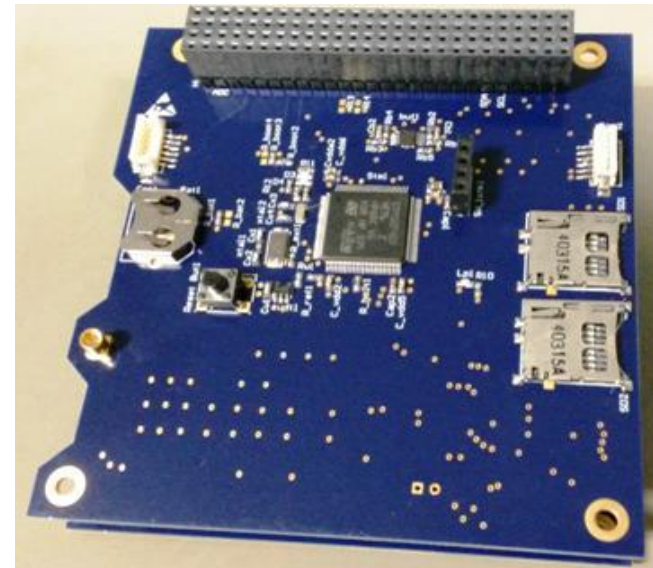

Satellite	Uplink	Downlink
BeEagleSAT	145.985 MHz	437.370 MHz
HAVELSAT	145.935 MHz	436.845 MHz



- 2 UHF
- 2 VHF
- Kenwood TS-200 (plus TNC)

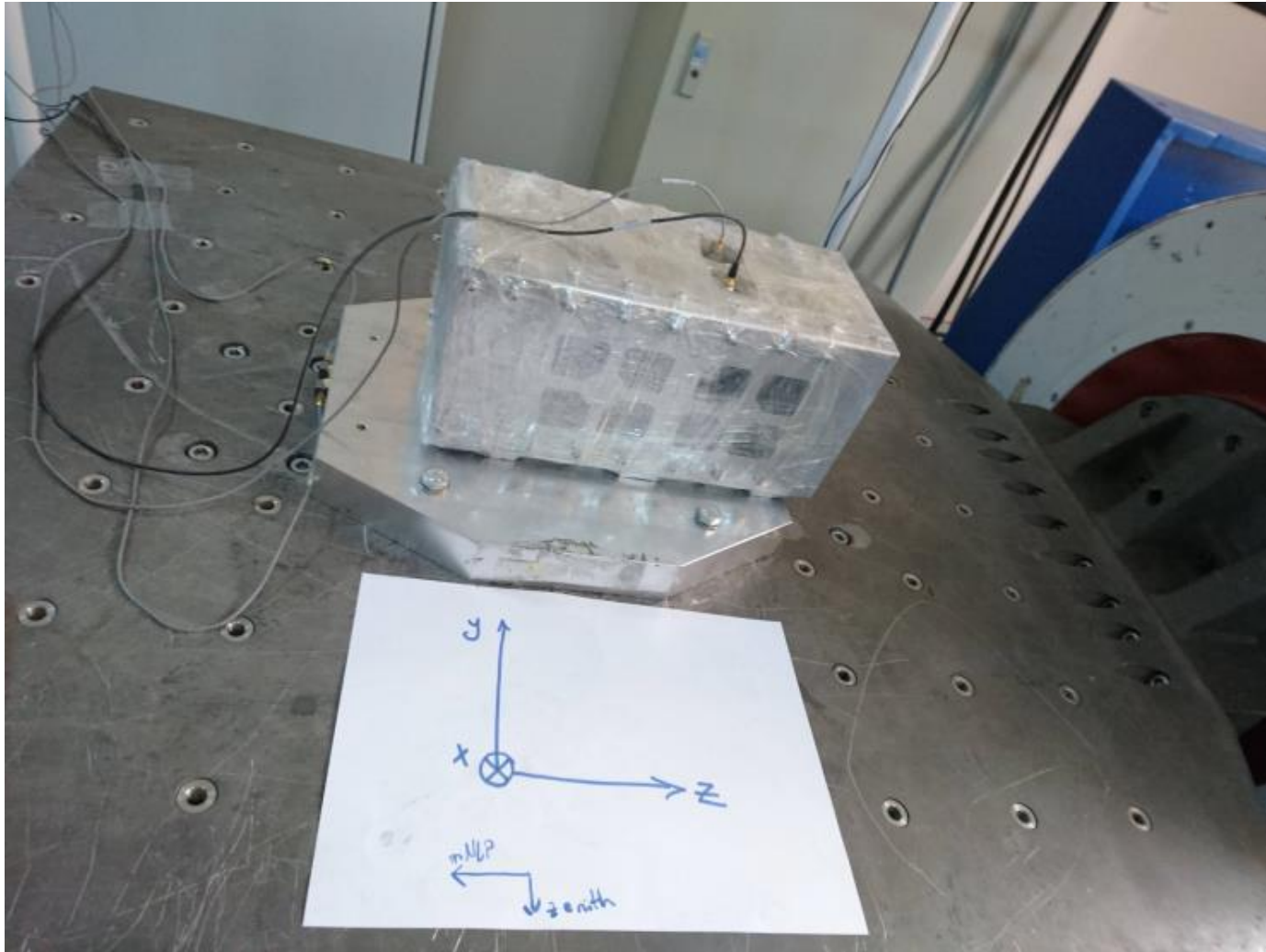

VIBRATION TEST (in house facility)

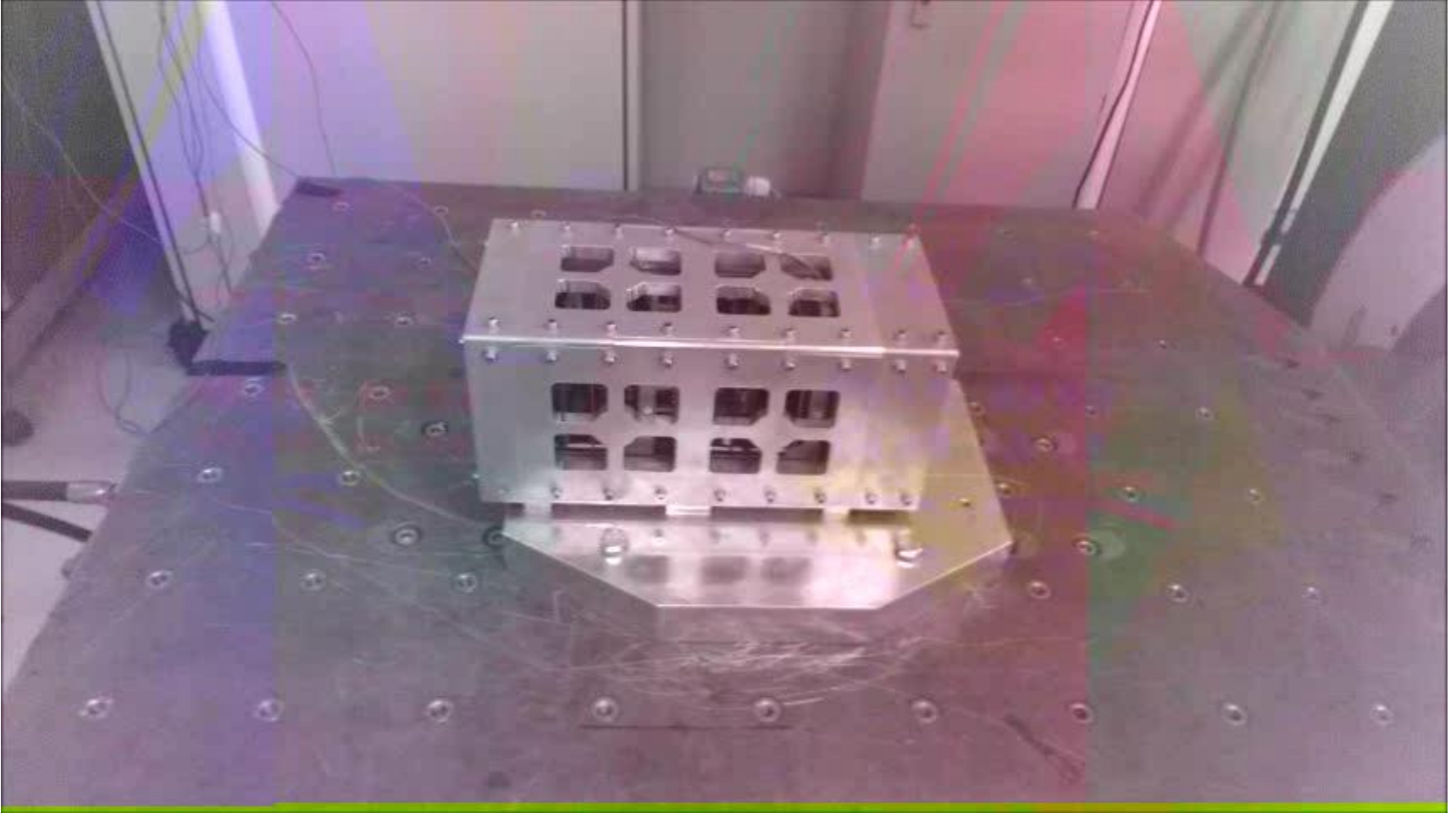

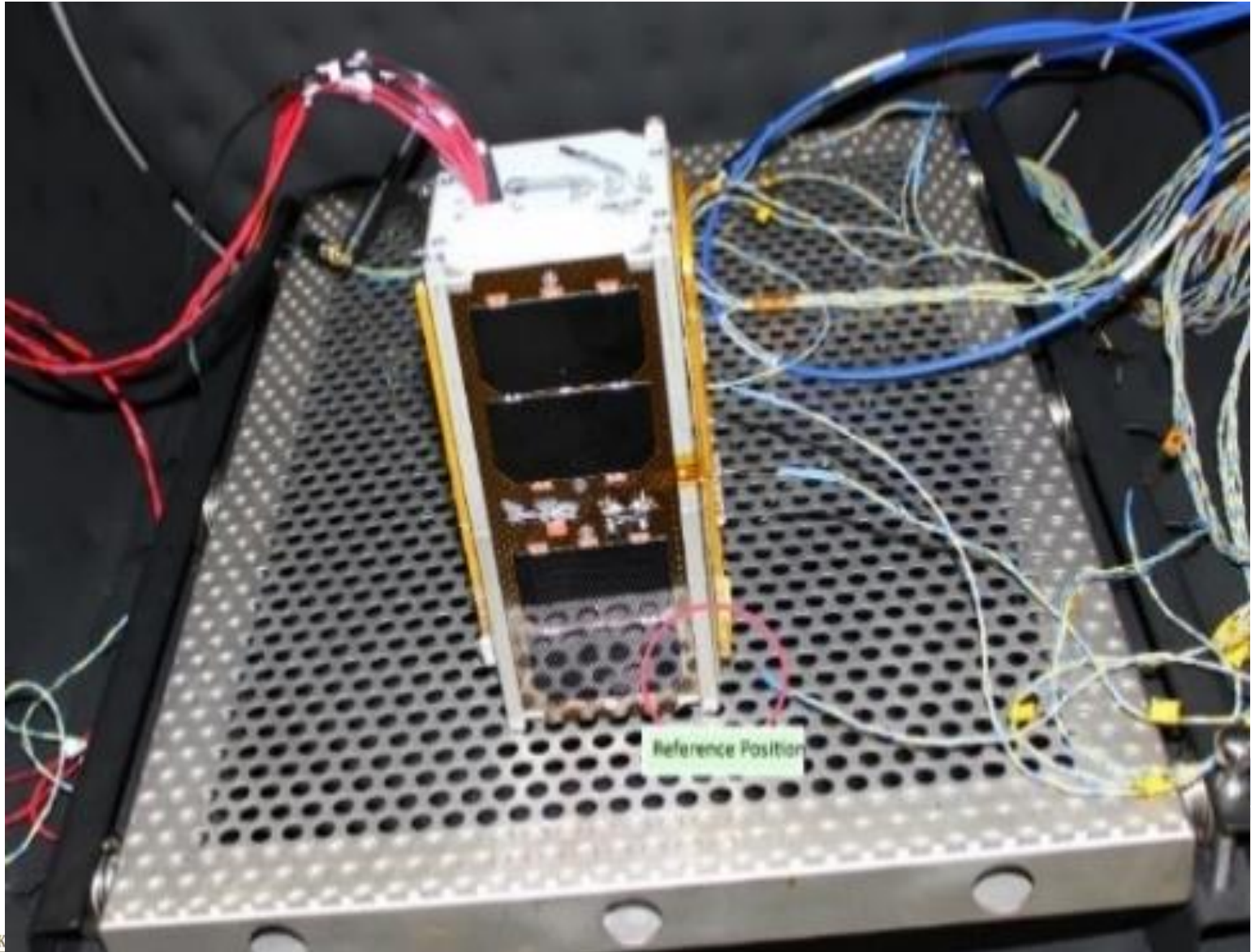

Min temperature	$-20 \pm 2 \text{ }^{\circ}\text{C}$
Max temperature	$+50 \pm 2 \text{ }^{\circ}\text{C}$
Temperature variation rate	$\geq 1 \text{ }^{\circ}\text{C}/\text{min}$
Dwell time	1 hour at extreme temperatures
Vacuum	10-5 mBar
Cycles	4

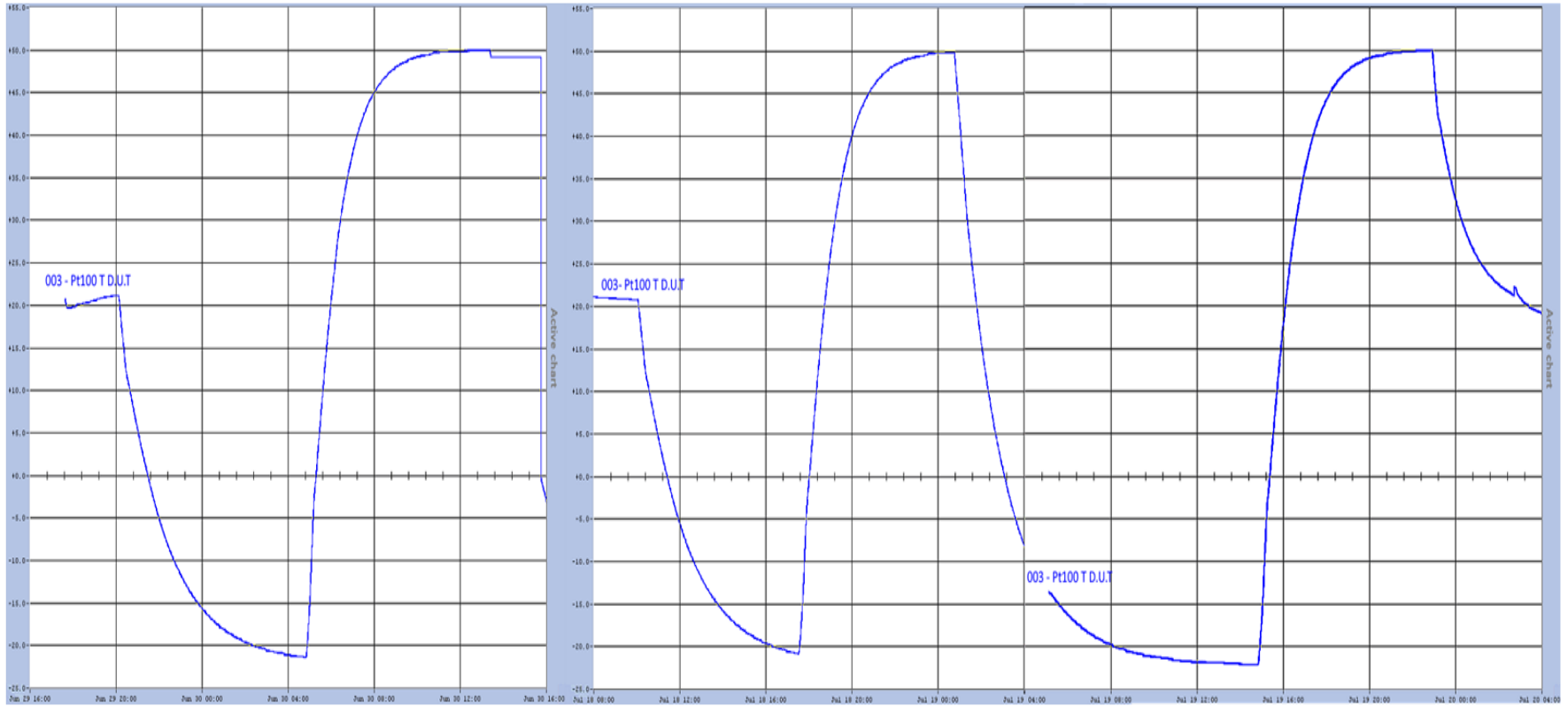

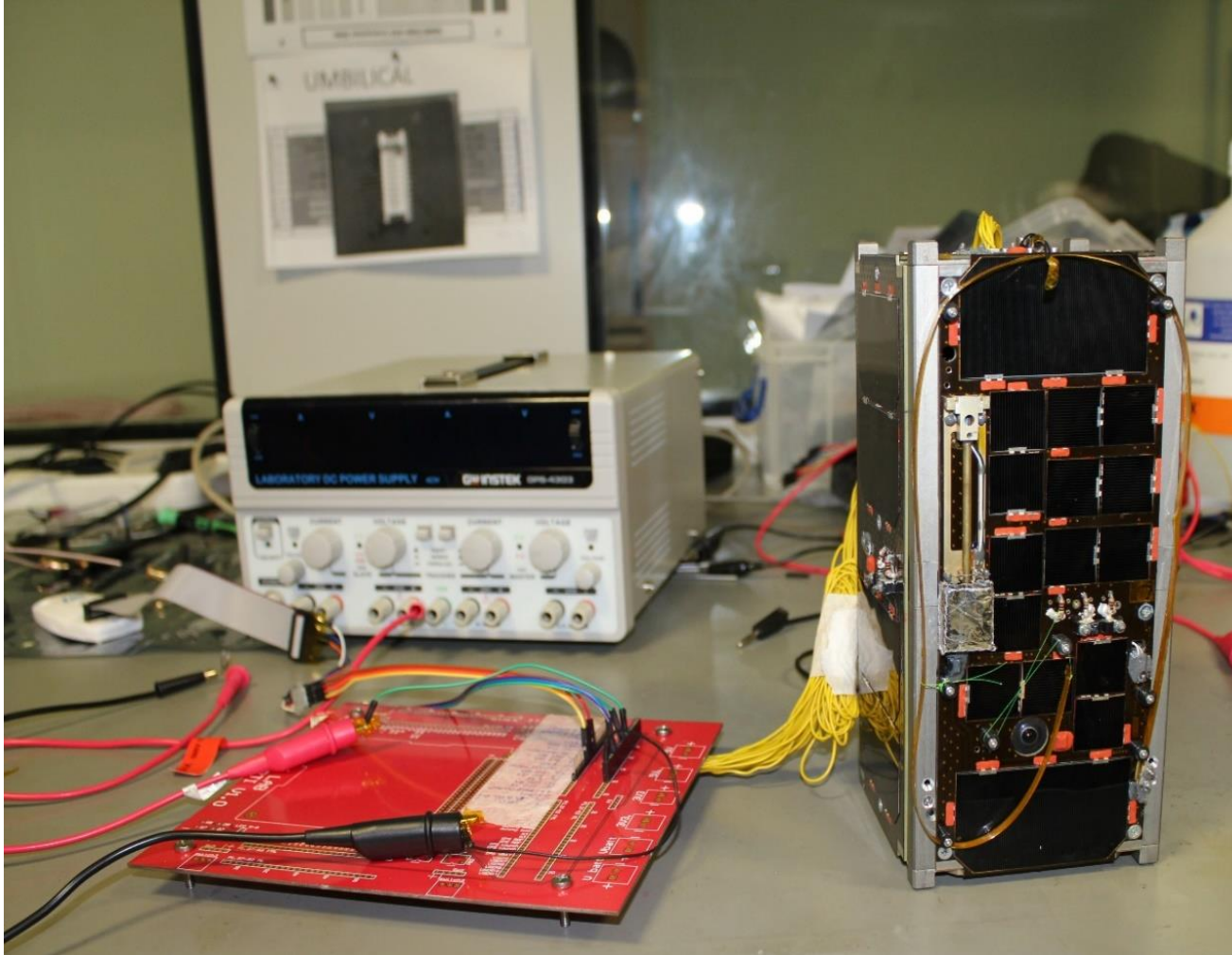

Concept of Operations & Timeline

Deployment + time (minutes)	Event
0	Power to EPS, OBC, BEACON, MODEM and CONTROL CARD (CC)
30	Deploy M-NLP Booms and Communication Antennas
60	Modem Rx is on
65	Beacon is on.
70	Power on ADCS.
75	Start to collect WOD data.
~ 1 Month	M-NLP begins to collect data.



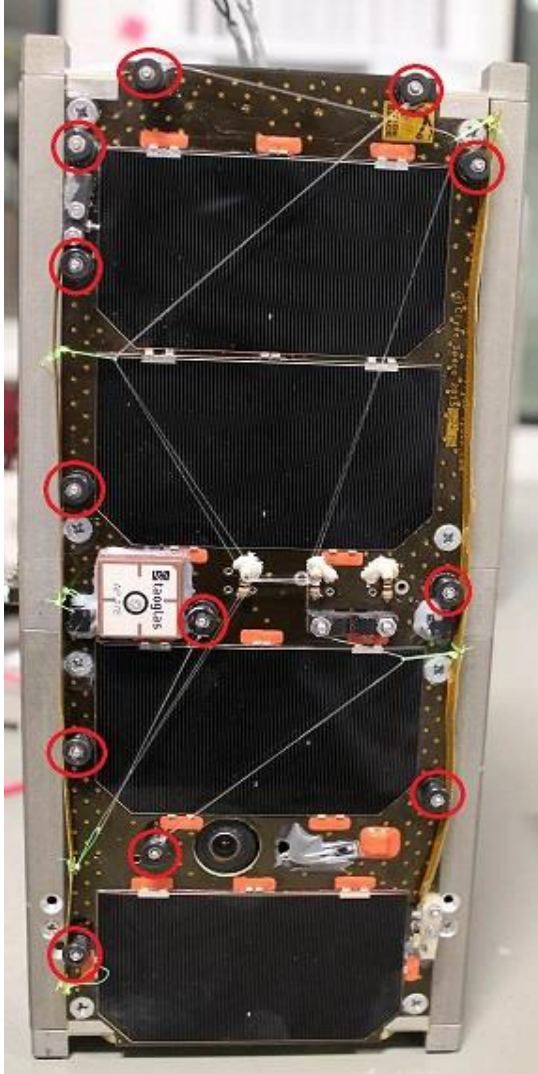

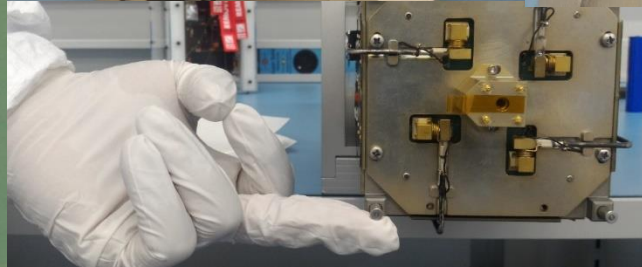
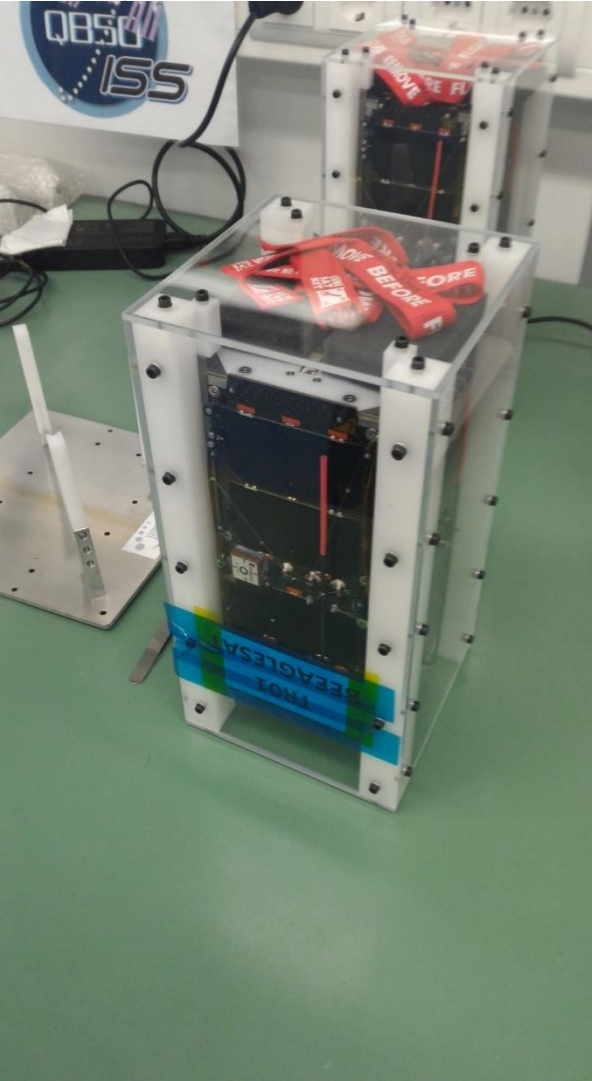

TR01 and TR02 in
NRCDS



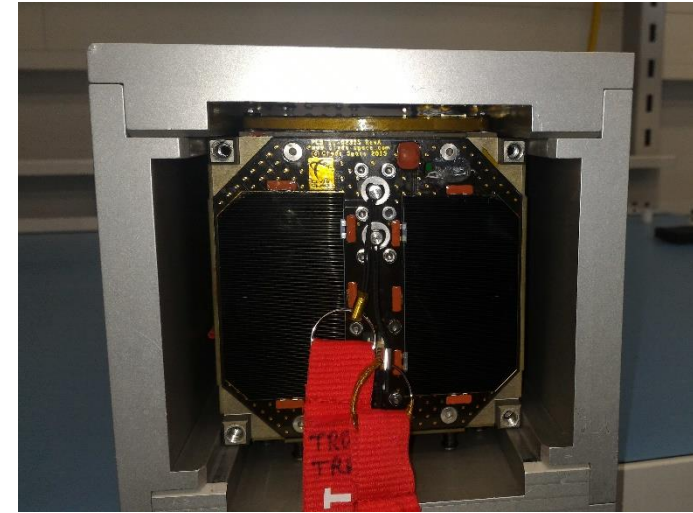
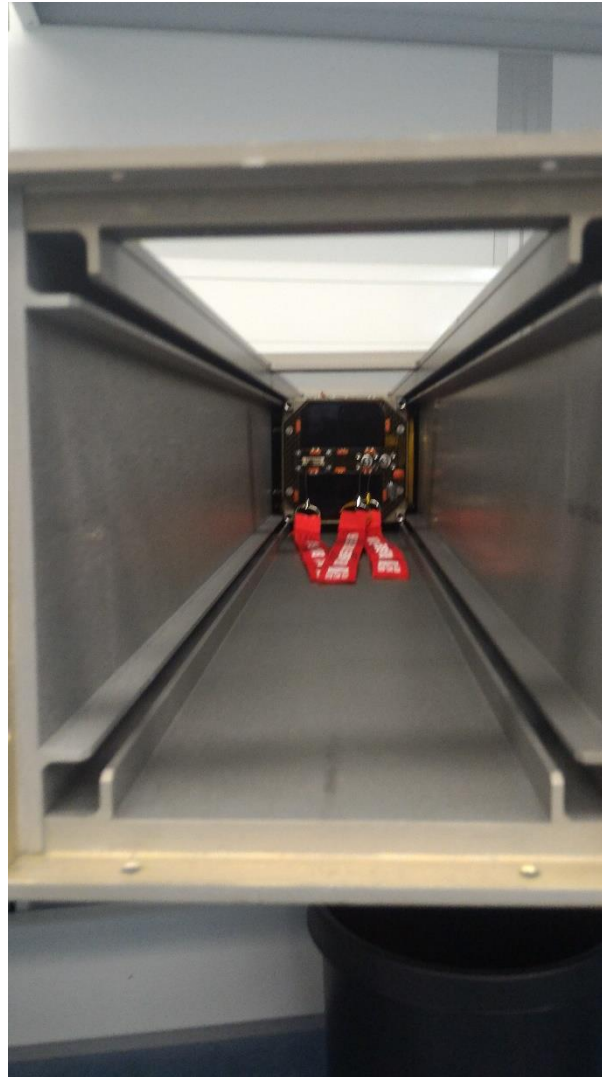
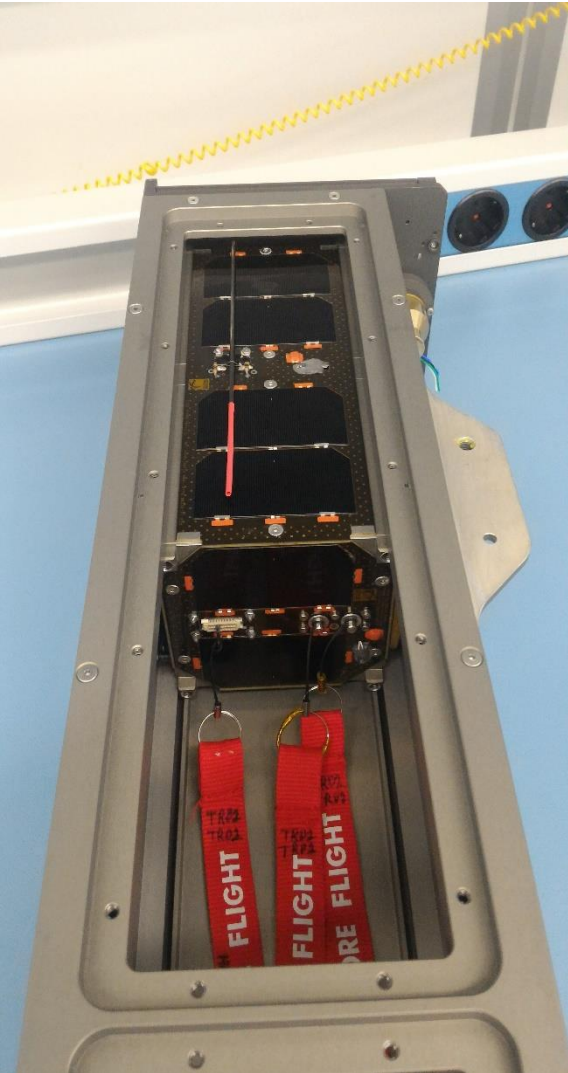



We Look Forward To a Fruitful Cooperation

Towards being a civilization living
in the Solar System

Space Systems Design and Test Lab

Istanbul Technical University
Department of Space Engineering

+90532 480 3449

aslanr@itu.edu.tr , uludagm@itu.edu.tr

www.usttl.itu.edu.tr



Thank you!

Uzay Sistemleri Tasarım ve Test Laboratuvarı
(Space Systems Design and Test Lab.)
www.usttl.itu.edu.tr

Prof. Dr. Alim Rüstem Aslan – aslanr@itu.edu.tr
Mehmet Şevket Uludağ – uludagm@itu.edu.tr

