

Drawer Slide Installation Guide

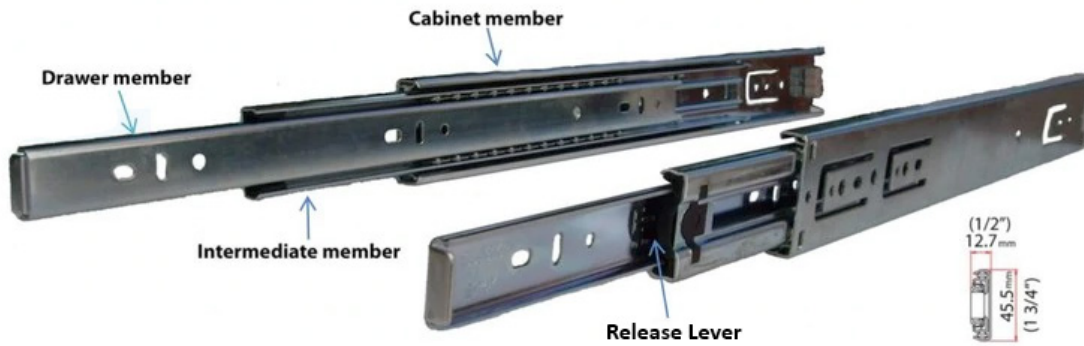

NOTE: Drawer needs 1/2" clearance on both sides to accommodate slides.

1. Before installing the slides, separate the cabinet and drawer members. Note that the release lever moves upward on the left hand side and downward on the right hand side.

i
 Drawer must be 1/2" narrower than cabinet opening on each side. Top and bottom drawer should have 1/8" minimum clearance from the cabinet opening.
 i

2. Install Cabinet Member:

- Using a level, place and align cabinet member into position inside the cabinet. For **Overlay Drawer Fronts**, align the front of the cabinet member with the front edge of the cabinet. For **Insert Drawer Fronts**, setback the front of the cabinet member the thickness of the drawer front.
- Fasten each side with two pan head wood screws into the horizontal slots. You will need to move the slide member back and forth to access the screw holes.

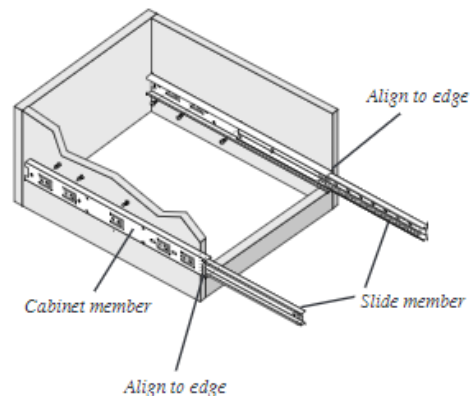

3. Install Drawer Member:

- Align the front edge of the drawer member with the front edge of the drawer box.
- Fasten each member with two pan head screws in the vertical slots.

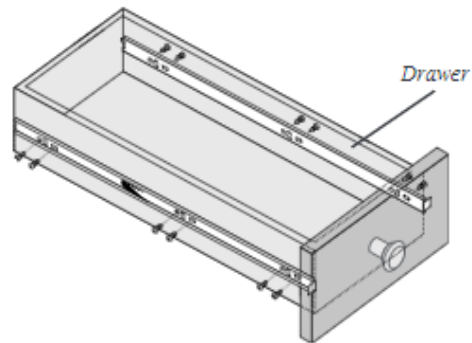

4. Insert Drawer:

- Insert drawer into cabinet and close. The drawer release lever will lock as drawer is closed.
- If necessary, adjust the height of the drawer using the vertical slots on the drawer member and the depth of the drawer by adjusting the horizontal slots on the cabinet member.
- When all adjustments are complete, install an additional screw in the center hold on the cabinet and drawer member to lock the slide members in position. At least two locking screws per member are recommended for supporting heavy objects to avoid tear out of slide.

