

htc®



User Guide

Contents

Introduction

About VIVE Mars CamTrack	5
What's inside the box?	5

Hardware

SteamVR Base Station 2.0	8
VIVE Tracker (3.0)	9
Rover	9
Mars	10
Calibration kit	12

System setup

Setting up VIVE Mars CamTrack	13
Example virtual production studio setup	15
Connecting Mars to your PC	15
Mounting VIVE Tracker (3.0) to Rover	16
Connecting Rover to Mars	17
Setting up the base stations	18
Tips for setting up the base stations	19
Adding Mars as an endpoint in Unreal Engine	20
Enabling FreeD on Mars and adding Mars to Aximmetry	20
Manually updating the Mars firmware	23

Camera calibration

Setting up the calibration board	25
Collecting calibration data using the Camera Calibration Tool	26
Importing calibration data into Unreal Engine	29

Real-time compositing in Unreal Engine

Creating a project with a virtual production template	34
Connecting to Mars using the Live Link plug-in	36
Setting up the virtual camera using the Live Link Controller	37
Configuring the media source using Composure	40

FAQs

How many base stations can I use?	44
Can I use an odd number of base stations?	44
Cleaning the base stations	44
Can I use more than one VIVE Tracker (3.0)?	45
Why does VIVE Tracker (3.0) automatically turn off?	45
How do I verify that VIVE Tracker (3.0) is detected?	45
What does the status light on VIVE Tracker (3.0) mean?	45
Why doesn't the VIVE Tracker (3.0) status icon on the Mars dashboard turn blue?	45
Troubleshooting VIVE Tracker (3.0)	45
Why can't I see the incoming video feed in the Camera Calibration Tool?	45

Trademarks and copyrights

About this guide

The following symbols indicate useful and important information.



Notes provide details on setup, answers to common questions, and information on what to do in specific situations.



Tips provide supplemental information or alternative methods you may find helpful for particular steps or procedures.



Important notes provide information needed to complete certain tasks or configure specific settings or features.



Warnings provide critical information for avoiding potential problems or preventing damage to hardware.

Introduction

About VIVE Mars CamTrack

VIVE Mars CamTrack is a solution that integrates VIVE Tracker (3.0), SteamVR Base Station 2.0, and a suite of other devices and tools to help you incorporate VR tracking technology into your virtual production projects.

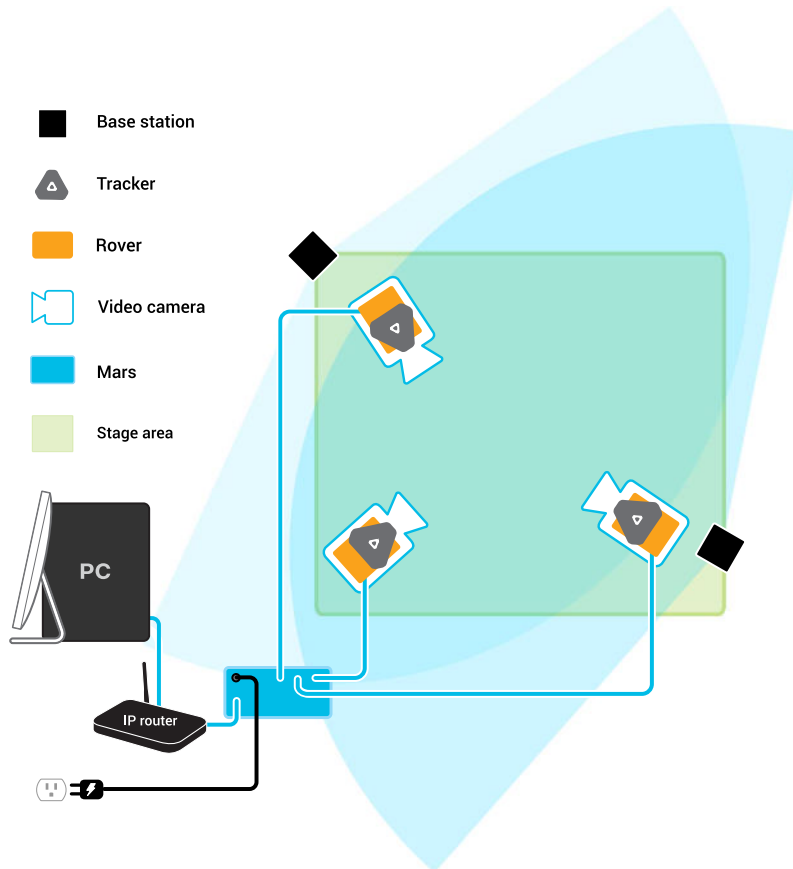

What's inside the box?

The packaging includes everything you'll need to set up your virtual production studio, as well as documentation to help you get started.

Here's what you'll find inside the box:

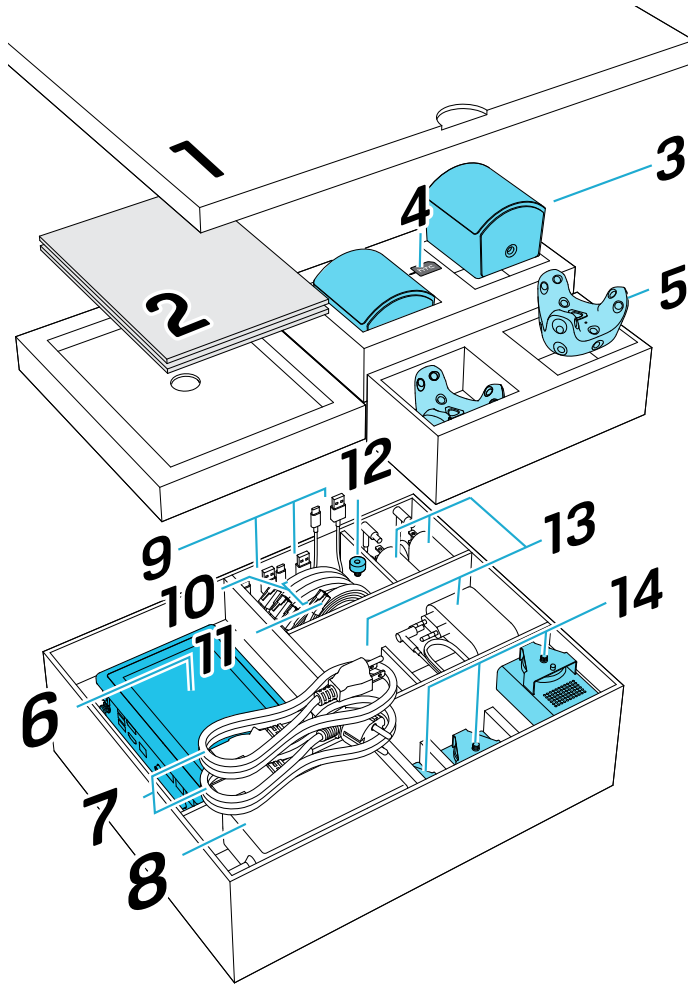

No.	Item	Quantity
1	Calibration kit	1
2	Documentation	-
-	Quick Start Guide	1
-	Safety guide	1
-	Warranty certificate	1
3	SteamVR Base Station 2.0	2
4	Channel changing pin (for base station)	1
5	VIVE Tracker (3.0)	2
6	Mars	1
7	Power cord for Mars*	1
8	AC adapter for Mars	1
9	USB cable (VIVE Tracker (3.0) to Rover)	3
10	15-m LAN cable (Mars to Rover)	3

No.	Item	Quantity
11	5-m LAN cable (Mars to router)	1
12	Screw for calibration board	1
13	AC adapter for base station*	2
14	Rover**	3

*Items may vary according to country or region.

**A third VIVE Tracker (3.0) must be purchased separately.

If you have questions or concerns about VIVE Mars CamTrack, or if you want to report damaged or missing items, go to vive.com/support/contactus to contact the VIVE Support team.

Hardware

SteamVR Base Station 2.0

SteamVR Base Station 2.0 uses advanced optics to determine the exact location of each VIVE Tracker (3.0) and Rover module.



- The base stations transmit signals to VIVE Tracker (3.0). Make sure the lines of sight between the base stations and the VIVE Tracker (3.0) units are not obstructed.
- The signals transmitted by the base stations may interfere with nearby infrared sensors, including those used by infrared remote controls.

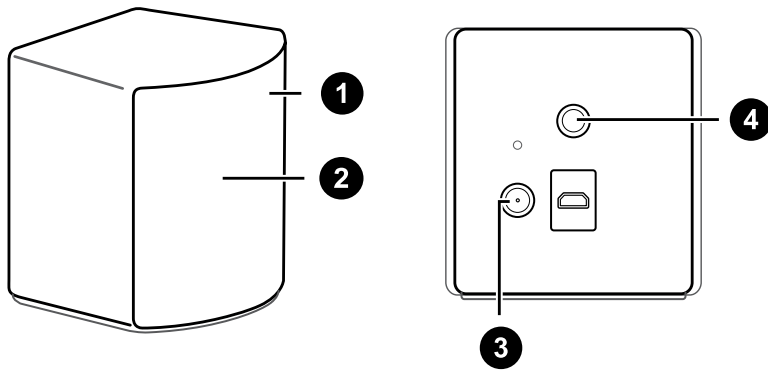

1	Status light
2	Front panel
3	Power port
4	Threaded mounting hole



- Do not attempt to force open the base stations for any reason. Doing so could injure you or damage the product.
- If the front panel of a base station is cracked or damaged, stop using the base station immediately and contact the VIVE Support team.

Visit [VIVE Support](#) to learn more about Base Station 2.0.

VIVE Tracker (3.0)

VIVE Tracker (3.0) sends location data to the Rover module it's attached to.

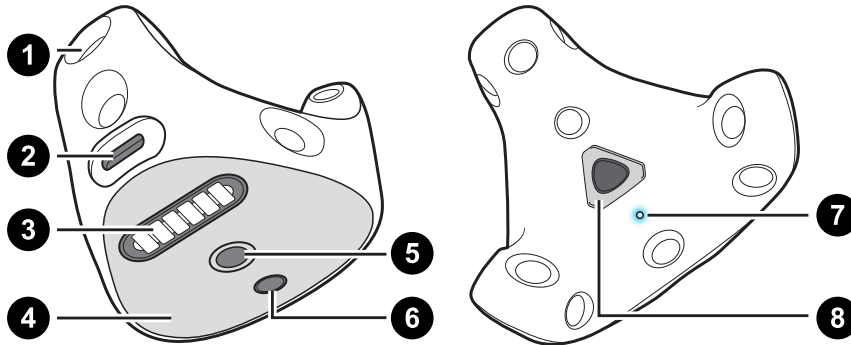

1	Sensors
2	USB Type-C® port
3	Pogo pin port
4	Friction pad
5	Standard camera mount
6	Stabilizing pin recess
7	Status light
8	Power button

Visit [VIVE Support](#) to learn more about VIVE Tracker (3.0).

Rover

Rover sends tracking data from VIVE Tracker (3.0) to Mars.

Rover collects tracking data from VIVE Tracker (3.0) and relays it to Mars to refresh the signal and prevent signal degradation.

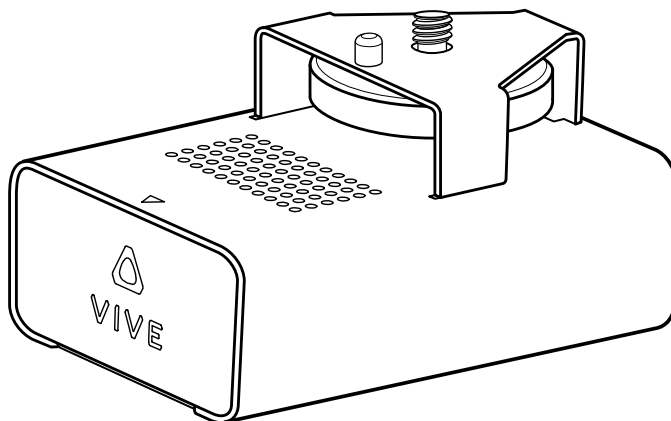

Rover is also responsible for transmitting FIZ (focus, iris, zoom) data that the lens encoder can convert into data that can be used by virtual production engines. VIVE Mars CamTrack supports the LOLED Indiemark lens encoder.

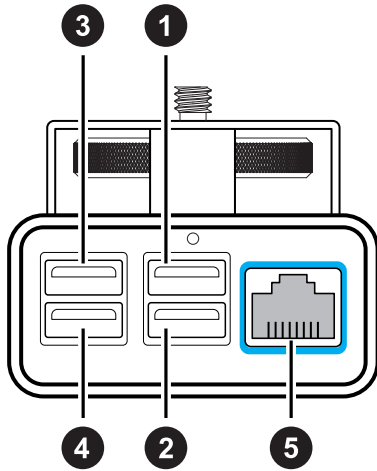

1	USB Type-A port 1	Primary connection port for VIVE Tracker (3.0)
2	USB Type-A port 2	Zoom data can be transmitted through this port
3	USB Type-A port 3	Focus data can be transmitted through this port
4	USB Type-A port 4	Iris data can be transmitted through this port
5	Ethernet port	For connecting Rover to Mars to transmit tracking data

Mars

Mars collects tracking data from each Rover and sends it to your PC through an IP router.

Mars allows you to manage each connected device and check relevant information through the Mars dashboard, which is located directly on the top side of Mars.

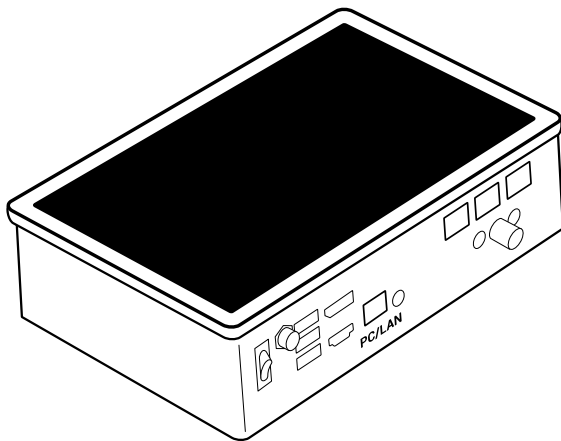

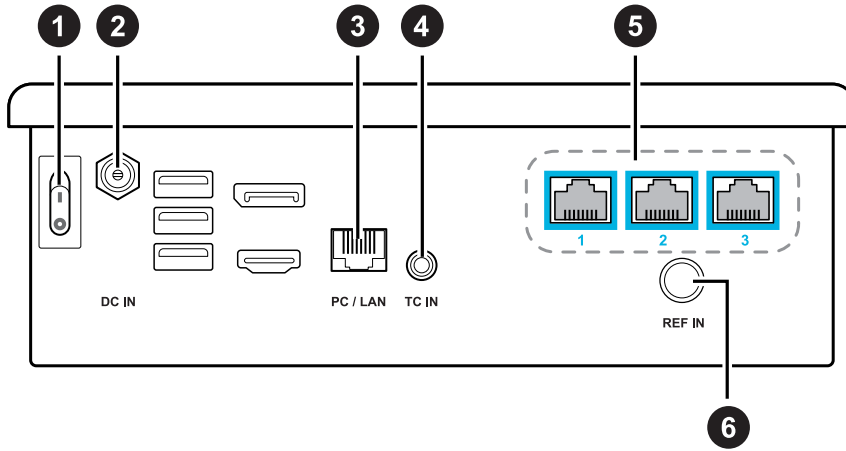

1	Power switch	For powering Mars on and off
2	DC power input	For connecting Mars to power
3	PC/LAN port	For connecting to IP router
4	TC input	For connecting timecode generator
5	Ethernet ports	For connecting Rover units
6	REF input	For connecting genlock generator

Mars dashboard

The Mars dashboard displays the connection status of each connected hardware device and other system-related information. You can also access several system configuration options.

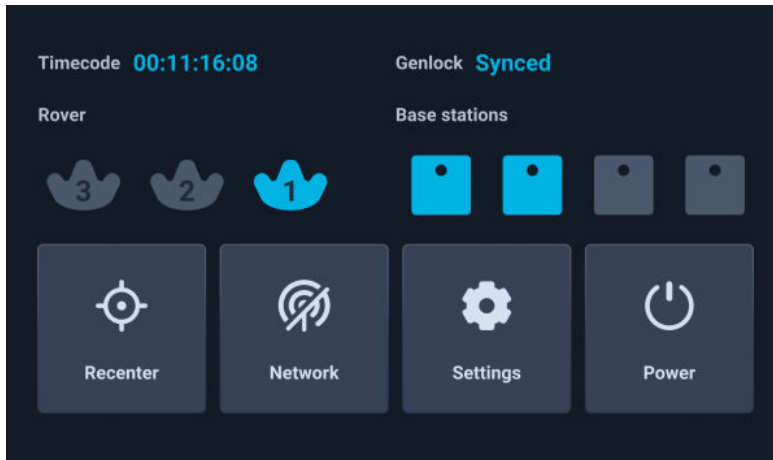

- **Rover:** The status of each Rover module is represented by a VIVE Tracker (3.0) icon.

Icon	Device status
Solid gray	No Rover module is detected.
Flashing gray	The Rover module is booting up.
Flashing blue	VIVE Tracker (3.0) is detected but not tracking yet.

Icon	Device status
Solid blue	VIVE Tracker (3.0) is detected and tracking.

- **Timecode:** Displays the timecode from a connected camera or sync generator.
- **Genlock:** The status **Synced** will be displayed when an external sync generator is connected.



An external sync generator is required to use this feature.

- **Base stations:** Displays the connection status of each base station.
- **Recenter:** Reset the coordinates of a tracker to a positional origin (neutral coordinates).
- **Network:** Displays the IP address when the network status is active. Tap to configure network settings.
- **Power:** Tap to restart or power off Mars.
- **Settings:** Configure additional settings and check for system updates. You can also export system logs for system diagnostics and analysis.

Calibration kit

The calibration kit includes items for assembling the calibration board, which is placed inside the tracking area during the camera calibration process.

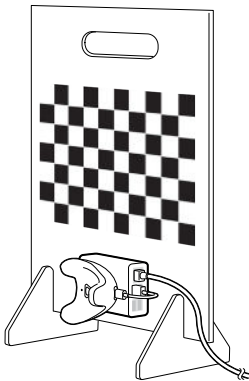

The calibration kit includes an acrylic calibration board with a chessboard pattern, which is used as the calibration target during camera calibration. The kit also includes base supports for the board and a screw for attaching a Rover module and VIVE Tracker (3.0), which is used to determine the location of the calibration target.

After setting up VIVE Mars CamTrack, you'll need to assemble the calibration board and attach a Rover module and VIVE Tracker (3.0) to it. You can then place the board inside the tracking area and start the calibration process. For details, see [Setting up the calibration board](#) on page 25 and [Collecting calibration data using the Camera Calibration Tool](#) on page 26.

System setup

Setting up VIVE Mars CamTrack

In addition to the included hardware components, you'll need an IP router and a PC equipped with a virtual production engine.

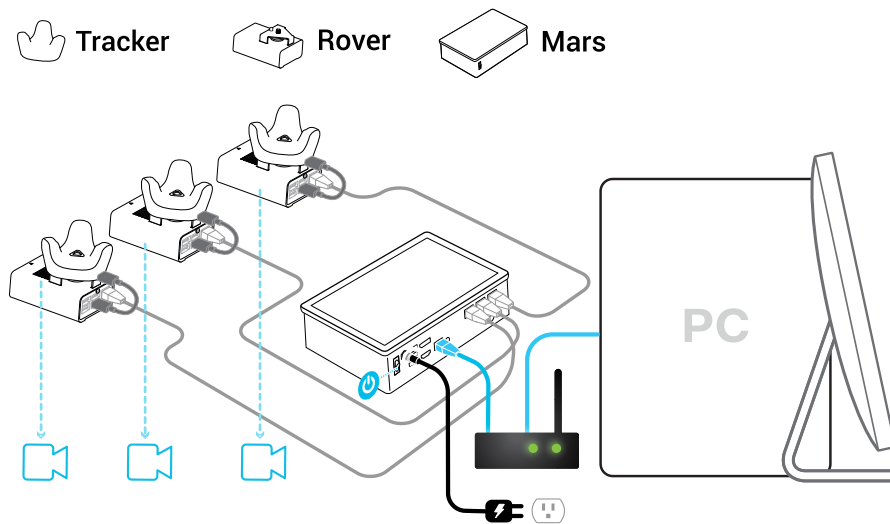

1. Connect Mars to your PC using an IP router.
See [Connecting Mars to your PC](#) on page 15.
2. Connect Mars to a power outlet using the included AC adapter and power cord.

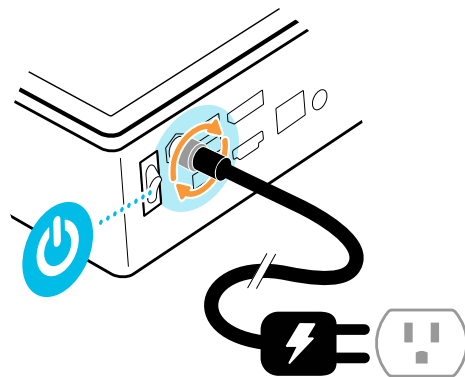

3. Power on Mars.
4. Mount VIVE Tracker (3.0) to Rover.
See [Mounting VIVE Tracker \(3.0\) to Rover](#) on page 16.

5. Connect Rover to Mars. Rover will turn on automatically.
See [Connecting Rover to Mars](#) on page 17.
6. Check the Mars dashboard to confirm that Rover is detected.
See [Mars](#) on page 10 for details on the Mars dashboard.



Even if the status light on VIVE Tracker (3.0) isn't green, it can still be tracked. Just check the status icon on the Mars dashboard to confirm the tracking status.

See [What does the status light on VIVE Tracker \(3.0\) mean?](#) on page 45 for details.

7. Set up the base stations, but **do not** connect them all to power at the same time. See [Setting up the base stations](#) on page 18.
8. Connect Mars to your virtual production software. See [Adding Mars as an endpoint in Unreal Engine](#) on page 20.
9. Set up the calibration board and start collecting calibration data. See [Setting up the calibration board](#) on page 25 and [Collecting calibration data using the Camera Calibration Tool](#) on page 26.

Example virtual production studio setup

You can mount Rover to any type of camera mounting accessory that uses a 1/4-inch screw.

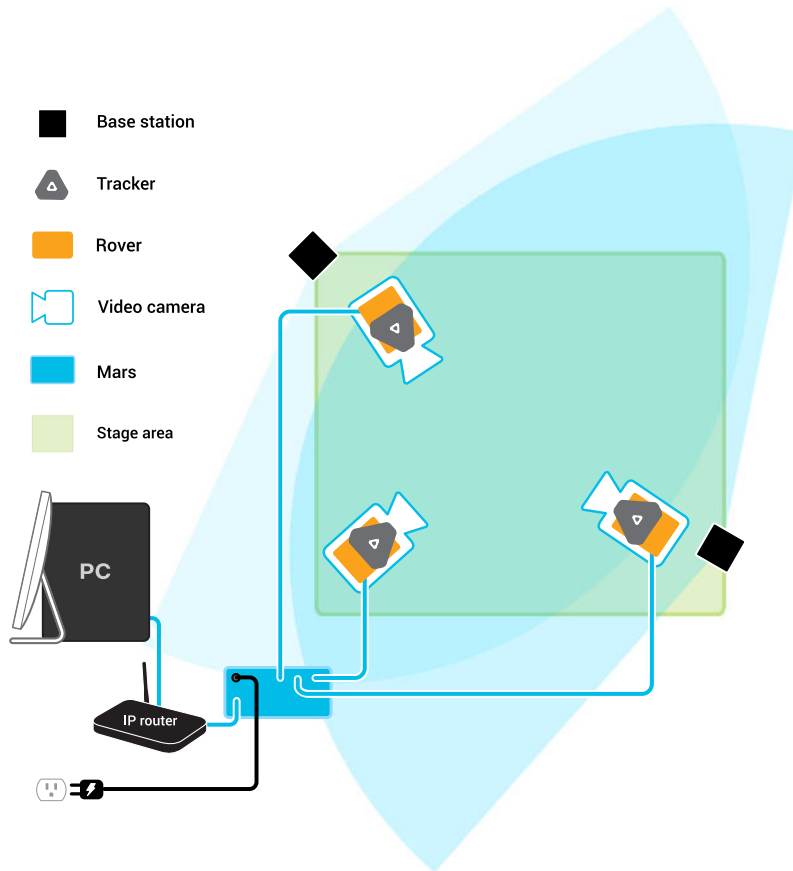

Connecting Mars to your PC

Mars processes positioning data and sends it to your PC through an IP router.

1. Connect one end of the 5-m LAN cable to the Ethernet port (labeled PC/LAN) on Mars.
2. Connect the other end of the 5-m LAN cable to an Ethernet port on your router.

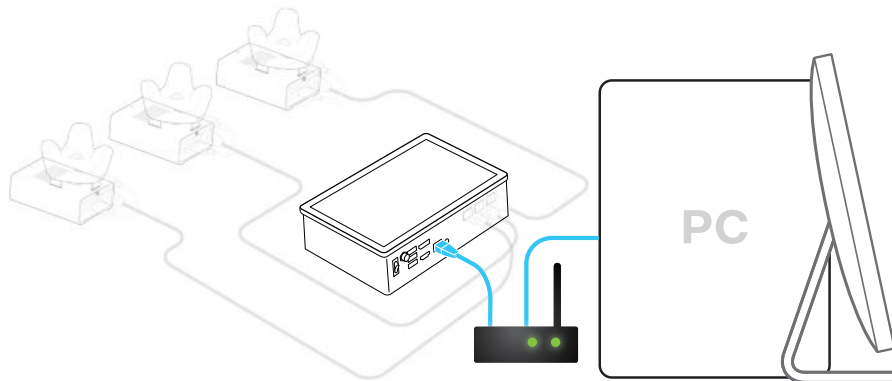

Mounting VIVE Tracker (3.0) to Rover

Rover comes installed with a mounting plate for mounting VIVE Tracker (3.0) to Rover.

1. Align the mounting screw on Rover with the screw hole on the bottom of VIVE Tracker (3.0).
2. Attach VIVE Tracker (3.0) to Rover and rotate the mounting screw counterclockwise until it is securely fastened.

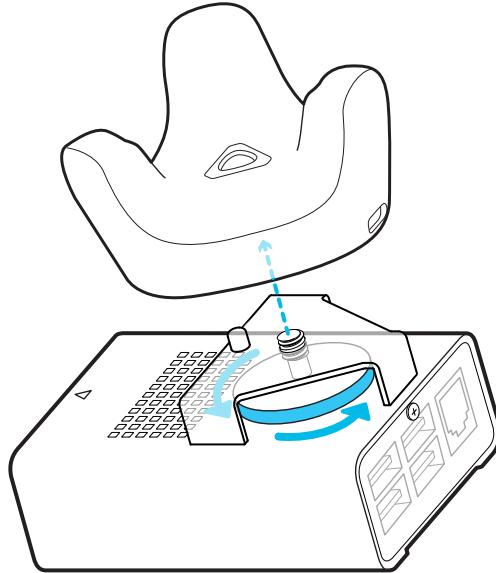

Make sure the front edge of the tracker is parallel to the front side of Rover, which is indicated by the blue arrow on the chassis. Failure to properly align the tracker may reduce the accuracy of camera calibration.

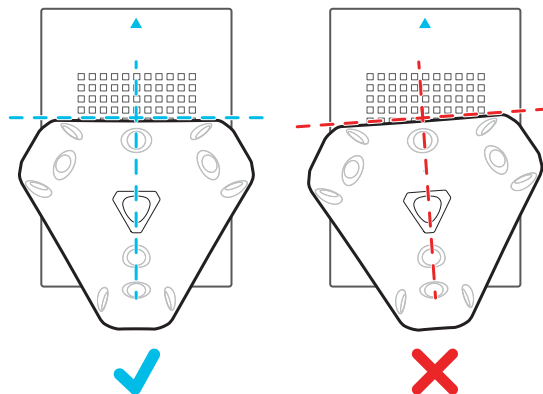

3. Connect the Type-C end of a 10-cm USB Type-C to Type-A cable to the USB Type-C port on VIVE Tracker (3.0), and then connect the Type-A end to a USB Type-A port on Rover.

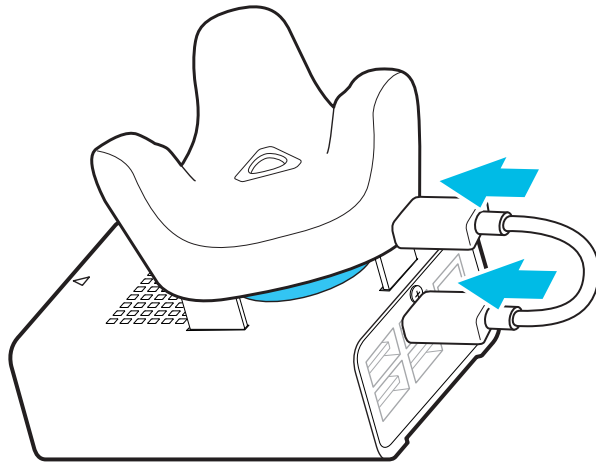

Connecting Rover to Mars

You can connect up to three assembled Rover modules to Mars at the same time.

! Only two assembled Rover modules can be connected to Mars during camera calibration— one for your camera, and one for the calibration board.

1. Connect one end of a 15-m LAN cable to the Ethernet port on Rover.
2. Connect the other end of the 15-m LAN cable to an Ethernet port on Mars.

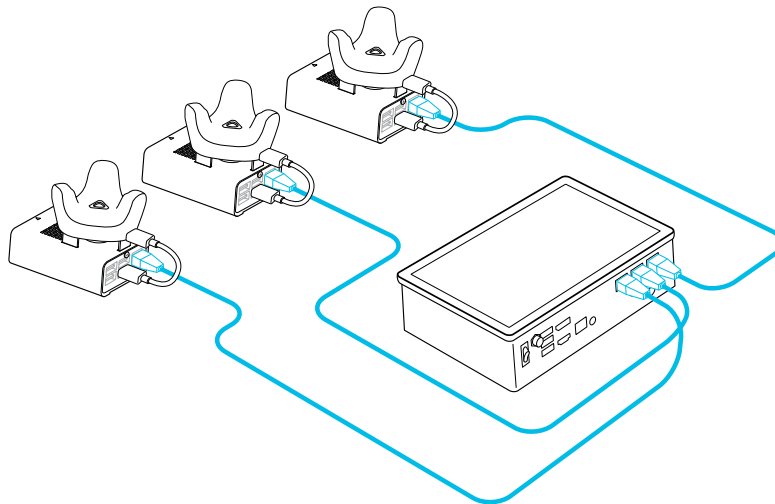

! Do not connect any third-party devices to Mars using these Ethernet ports. Doing so will void the warranty and may cause damage to Mars and any connected third-party devices.

Setting up the base stations

Here's how to set up the base stations for VIVE Mars CamTrack.

1. Mount the base stations at the edge of the tracking area near power outlets.



If you're not able to mount the base stations using the mounting kit, you can attach them to tripods or place them on a stable surface, as long as it's high enough.

For details on using the mounting kit, visit [VIVE Support](#).

2. Face each base station toward the center of the tracking area where you plan to set up the calibration board. See [Collecting calibration data using the Camera Calibration Tool](#) on page 26 for details.



Remember to peel the protective film off the front panels of the base stations.

3. Connect the base stations to power one at a time. Make sure the first base station is detected by Mars before connecting the second one.

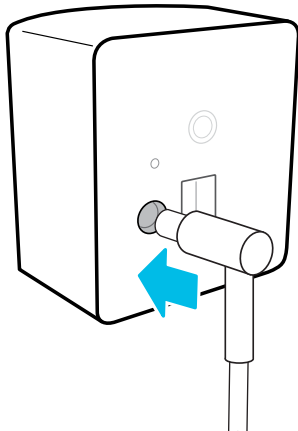

Only use the power cables and adapters included with the base stations.

Depending on the hardware version of your base stations, the LED indicators will be white or green.



If Mars doesn't automatically detect the base stations, press the channel button on the back with the channel changing pin to set the channel manually. You may need to set the channel manually for any additional base stations you connect.

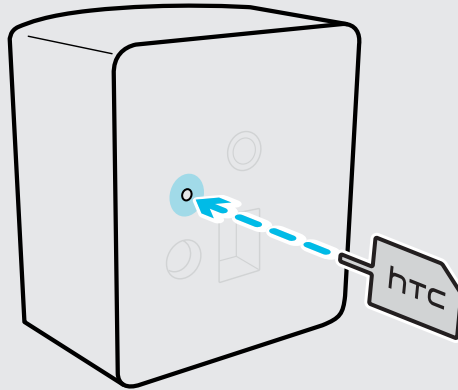

The status icon on the Mars dashboard will turn blue about 10-15 seconds after setting the base station channel.

Tips for setting up the base stations

Before setting up the base stations, make sure to prepare your production area based on the amount of space you have available.

The minimum area required for room-scale setup is 2 m x 1.5 m (6.5 ft x 5 ft).

Set up your base stations to fit the requirements of your studio space. For the best results, keep the following things in mind:

- Make sure the base stations are set up outside the production area and adequately secured to avoid damage or compromised performance.
- Each base station has a 150-degree horizontal field of view and a 110-degree vertical field of view. To maximize the scope of your production area, set up the base stations at least 2 m (6.5 ft) high and 5 m (16 ft) apart. In addition, make sure each base station is tilted down between 30 and 45 degrees.
- For optimal tracking, make sure VIVE Tracker (3.0) is at least 0.5 m (1.6 ft) away from each base station and that each base station is at least 0.5 m (1.6 ft) high. The height of the base stations determines how far up or down they need to be tilted to fully cover the production area.
- Avoid setting up the base stations under bright lights, which could negatively affect their tracking performance.
- After turning on the base stations, do not move or tilt them, as doing so could disrupt tracking. If you reposition the base stations, you'll need to set them up again.

Adding Mars as an endpoint in Unreal Engine

Before starting camera calibration, you'll need to add Mars as an endpoint in Unreal™ Engine.

1. Go to **Edit > Project Settings > Plugins > UDP Messaging > Static Endpoints**, and then click the **+** button.
2. Enter the Mars IP address and port number (in this example, **"6666"**).

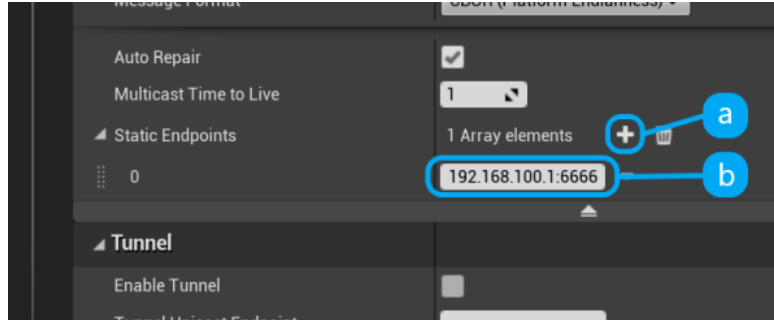

You can find the Mars IP on the Mars dashboard and the port number in the network settings. Just tap the network button to open the network settings.

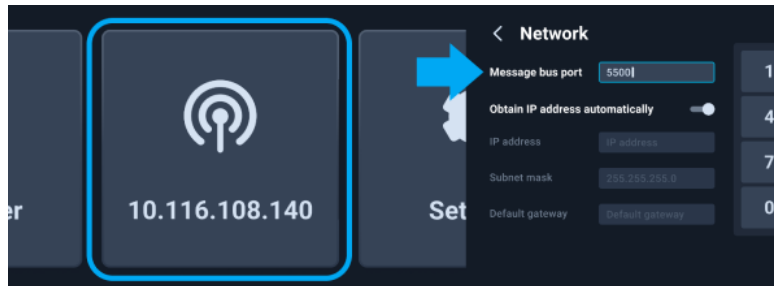

3. Click **+ Source**, go to **Message Bus Source** under **Live Link Sources**, and then click **VIVE Live Link** to open the Live Link plug-in.

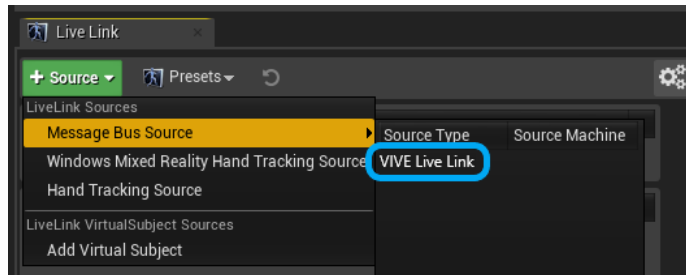

Enabling FreeD on Mars and adding Mars to Aximmetry

FreeD is an industry-standard protocol used by cameras to directly send tracking data—such as transform, rotation, focus, and zoom—to virtual production systems. It allows production systems to incorporate realistic virtual studio sets into video productions without the need for additional hardware.

Here's how to enable FreeD on Mars and add Mars to Aximmetry:

1. On the Mars dashboard, tap **Settings** and check your firmware version. Make sure you have Mars firmware 2.03.999.1 or later installed.

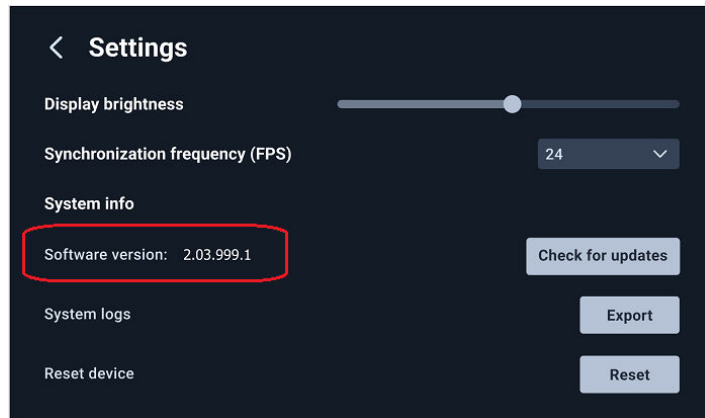

For details on how to update the firmware, see [Manually updating the Mars firmware](#) on page 23.

2. On the Mars dashboard, tap **Network** (or tap the Mars IP when the network is active), and then tap **Camera tracking protocols**.

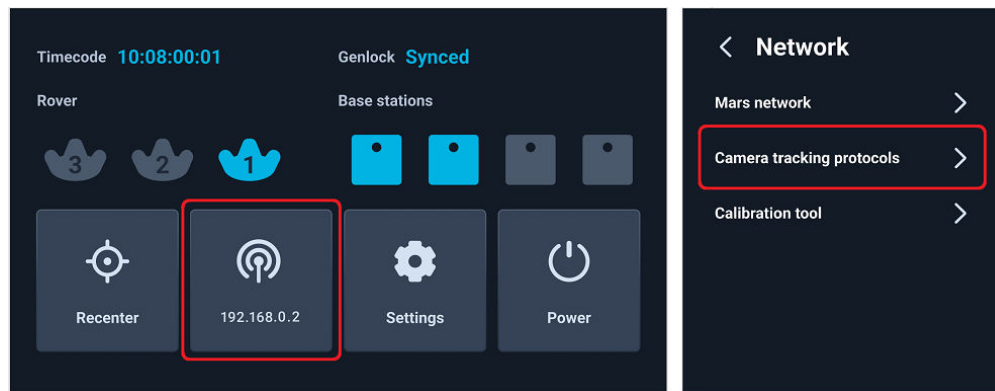

3. Turn on **FreeD** and enter your computer's IP address.

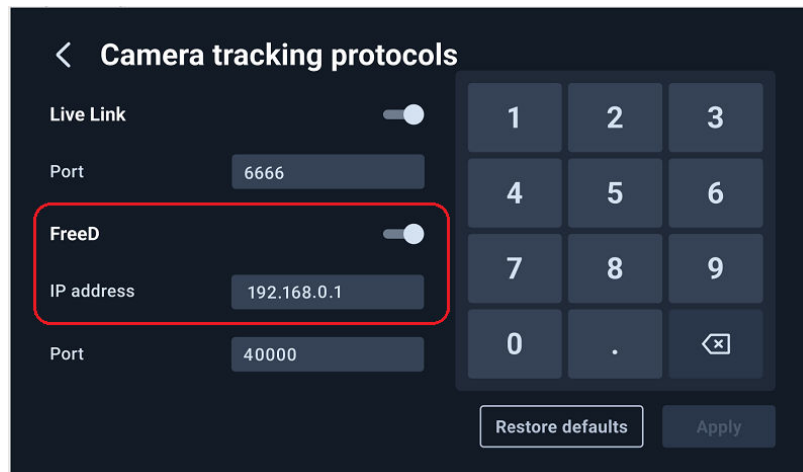

4. On your computer, launch Aximmetry. The Startup Configuration window will be displayed.
5. Click **Device Mapper** in the left pane.
6. Under Category, select **Camera Tracking**, and then click **Manage Devices**.

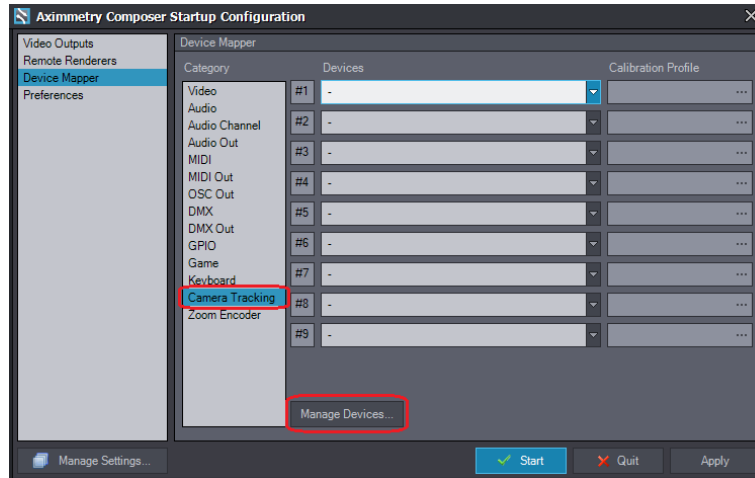

7. In the Manage Devices dialog box, select **Free-D** under Camera Tracking, and then click **Add**.

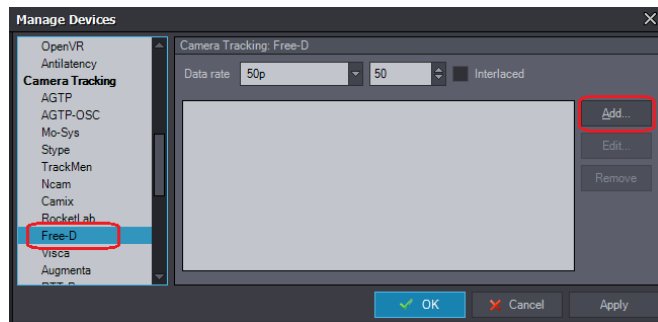

The Add Device dialog box will be displayed.

8. In the **UDP port** field, enter the port number that appears under **FreeD** on the **Camera tracking protocols** screen on the Mars dashboard.

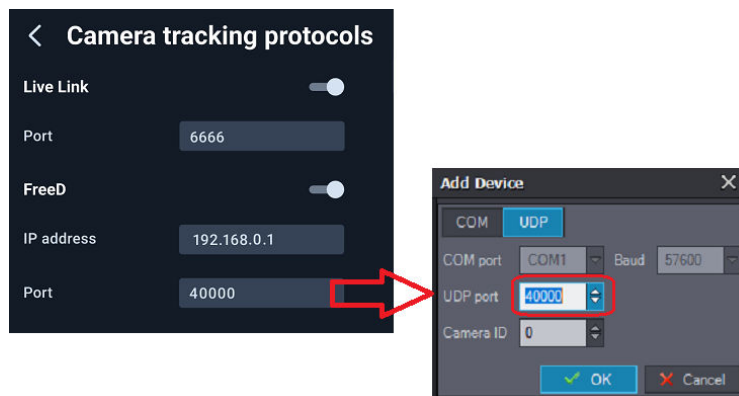

9. In the **Camera ID** field, select **1** to associate it with Rover 1's Ethernet port on Mars, and then click **OK**.
10. Repeat steps 7 to 9 to add Rover 2 and Rover 3. In the **Camera ID** field, select **2** and **3** respectively.

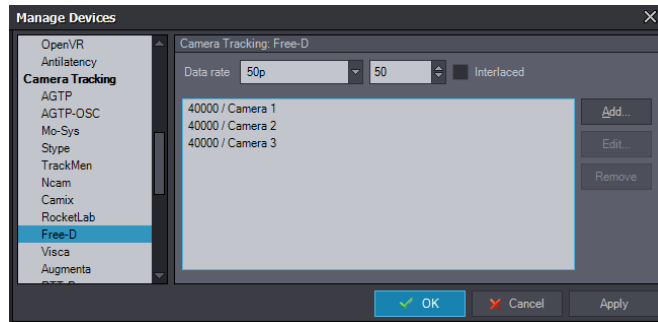

Manually updating the Mars firmware

Mars regularly checks for updates automatically. You can also update the firmware manually to get the latest features and enhancements.

1. Download the Mars firmware.
 - a) Go to <https://mars.vive.com/>.
 - b) Scroll down to the bottom of the page to find the **Support** section.
 - c) Click the **Mars Firmware** dropdown heading, and then click **Download**.

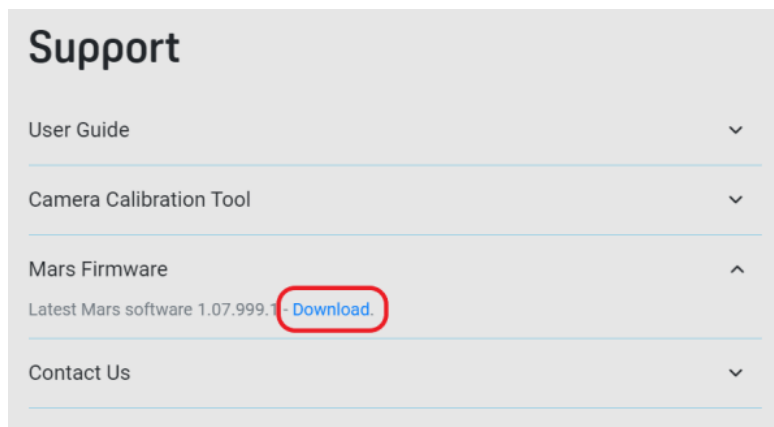

2. Copy the firmware update package to a USB Type-A flash drive.

3. Connect the flash drive to one of the three USB Type-A ports on the back of Mars.

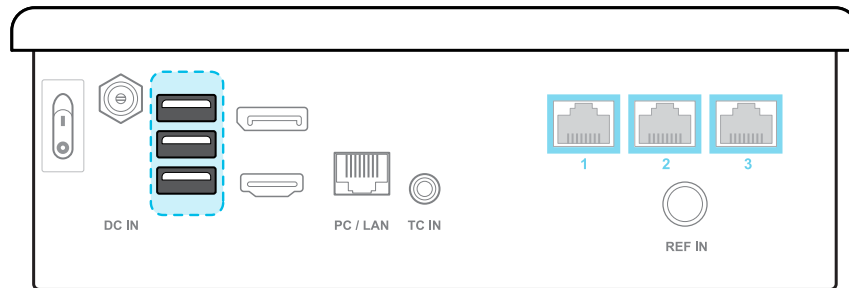

4. On the Mars dashboard, tap **Settings**, and then tap **Check for updates**.
For details on the Mars dashboard, see [Mars](#) on page 10.
5. Follow the onscreen instructions to install the firmware update package.

Camera calibration

Setting up the calibration board

Set up the calibration board and place it inside the tracking area on your set before starting the camera calibration process.

1. Attach the base supports to the calibration board.

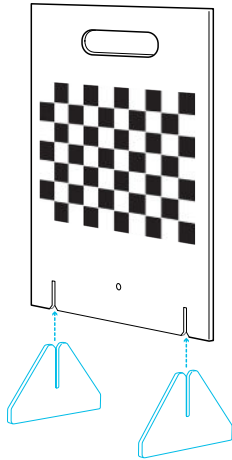

2. Attach an assembled Rover module to the calibration board under the chessboard pattern using the screw included in the box.

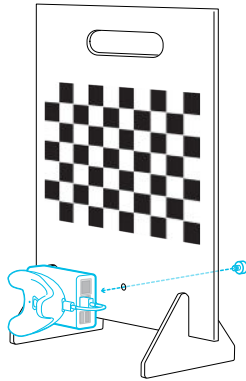

- Make sure the Rover module is securely attached to the calibration board. Any gaps between the board and the module could affect calibration.
- The in-box screw has an interior screw thread so you can install the Rover module and calibration board to a tripod for greater precision during calibration.

3. Place the calibration board inside the tracking area at the same height as the camera, with the camera facing the board at a 90-degree angle.

See [Example virtual production studio setup](#) on page 15 for details.



Make sure the calibration board doesn't obscure the Rover module from the base stations after rotating it 45 degrees in either direction. This will be important during camera calibration.

See [Collecting calibration data using the Camera Calibration Tool](#) on page 26 for details.

Collecting calibration data using the Camera Calibration Tool

The Camera Calibration Tool captures images to generate calibration data that you can import into your virtual production engine to calibrate your camera.

If you haven't downloaded the Camera Calibration Tool, visit www.vive.com/mars/cct.

1. Attach a Rover module to your camera, with the front side of Rover parallel to the camera lens.

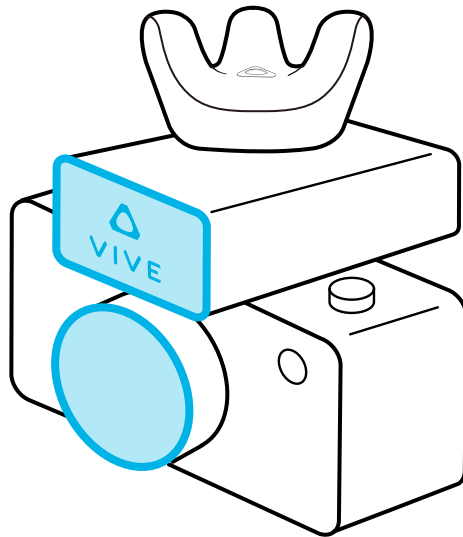

The internal screw thread on the bottom of Rover has a depth of 5.5 mm. To avoid damaging Rover or your camera during installation, make sure the exterior screw thread on your camera is no longer than 4.5 mm.

2. On your PC, open the Camera Calibration Tool, enter the Mars IP and port number, and then click **Connect**.

MARS IP/Port number ⓘ 10.116.105.11 5500 Connect



You can find the Mars IP on the Mars dashboard. See [Mars](#) on page 10 for details.

3. Select your video capture device from the **Video source** dropdown menu.

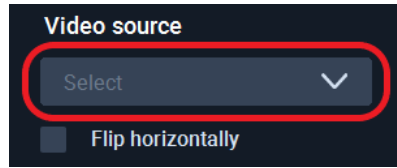

If the video feed is inverted on the x-axis, you can select **Flip horizontally** to correct it.

4. For **Save location**, click the folder icon  and select a destination folder for the images and calibration data.

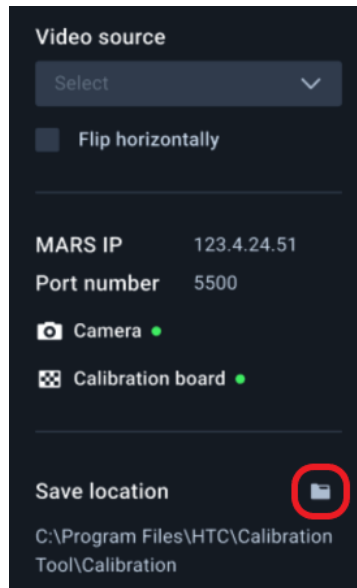

5. Click the play button to start the calibration process.
6. Move the camera so the chessboard pattern falls inside the red frame.

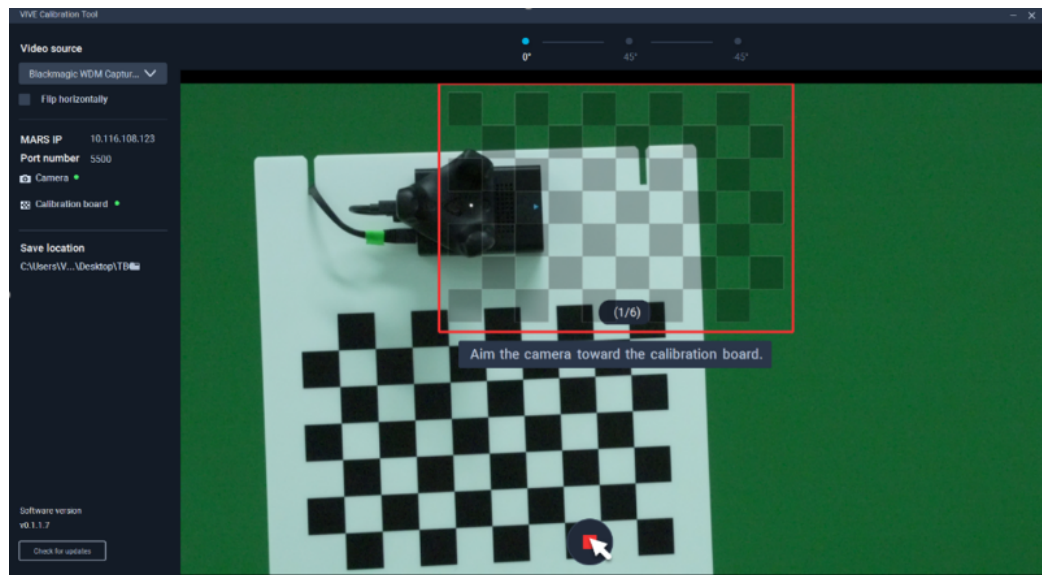

The frame will turn blue, and the Camera Calibration Tool will capture an image.

7. Move the camera as needed to capture additional images until you're prompted to rotate the calibration board.
8. Rotate the calibration board 45 degrees (counterclockwise), then click **Continue** and capture a second set of images.

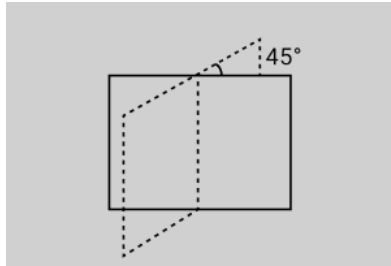

After capturing the second set of images, you'll be prompted to rotate the board 45 degrees in the opposite direction.

9. Rotate the calibration board 45 degrees clockwise (-45 degrees), click **Continue**, and then capture the third and final set of images.

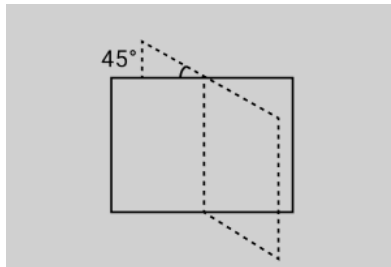

The Camera Calibration Tool will process the images and display the results. Click **Show in folder** to open the save location containing the images and calibration data.

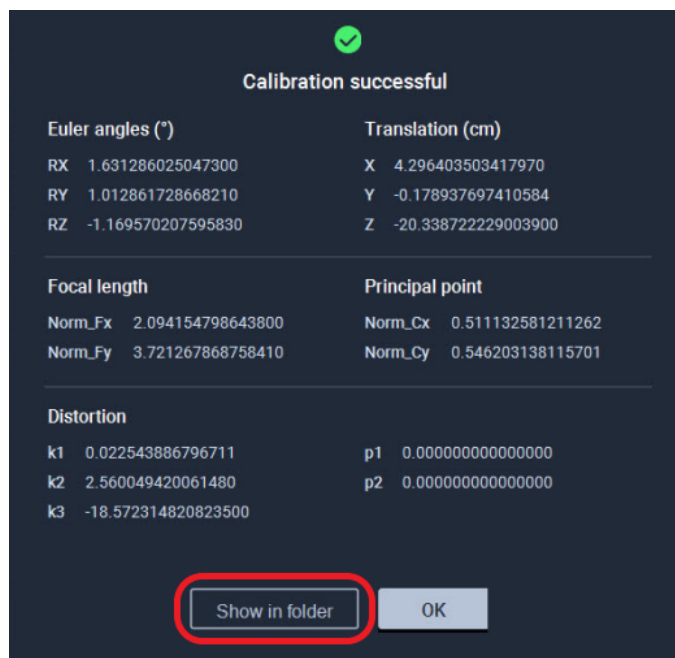

10. Import the calibration data into your virtual production engine to calibrate your camera. For details, see [Importing calibration data into Unreal Engine](#) on page 29.

Importing calibration data into Unreal Engine

Here's how to configure the virtual camera with the calibration data collected using the Camera Calibration Tool.

1. Open the TXT file containing the calibration data.
 - a) Open the save location and find **Calibration_Result.txt**.

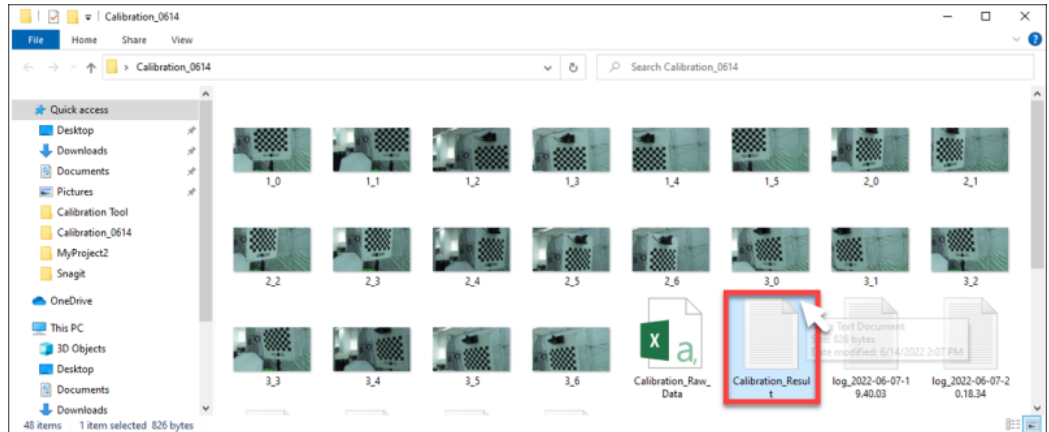

- b) Double-click the file to open it and view the calibration data. Keep the file open for reference.

```

Calibration_Result - Notepad
File Edit Format View Help
2022/06/14 14:07:58-
Euler (unit:degree):
1.55780243873596
0.77961266040802
-1.55513167381287

Translation (unit:cm):
8.35970230102539
1.45085420608521
-19.6163955688477

Focal length (Norm_Fxy):
1.27871391179044
2.2729528235003

Principal point (Norm_Cxy):
0.509477092550921
0.535811494055578

Distort (k1,k2,p1,p2,k3):
-0.20086824625772
0.370794559417618
0
0
-0.681560102689194
  
```

2. In Unreal Engine, enable the **Camera Calibration** plug-in.
 - a) Click **Settings > Plugins** to open the **Plugins** browser tab.

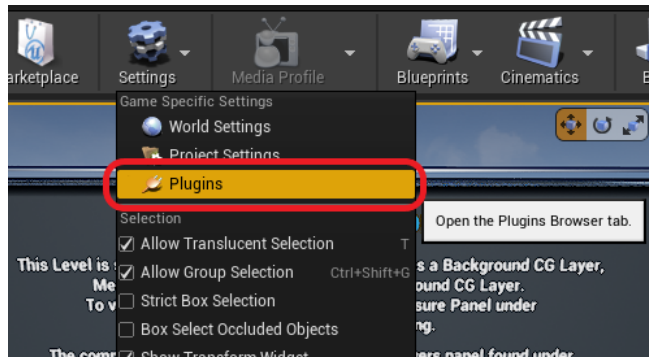

- b) Search for camera calibration and then select **Enabled** under the **Camera Calibration** plug-in.

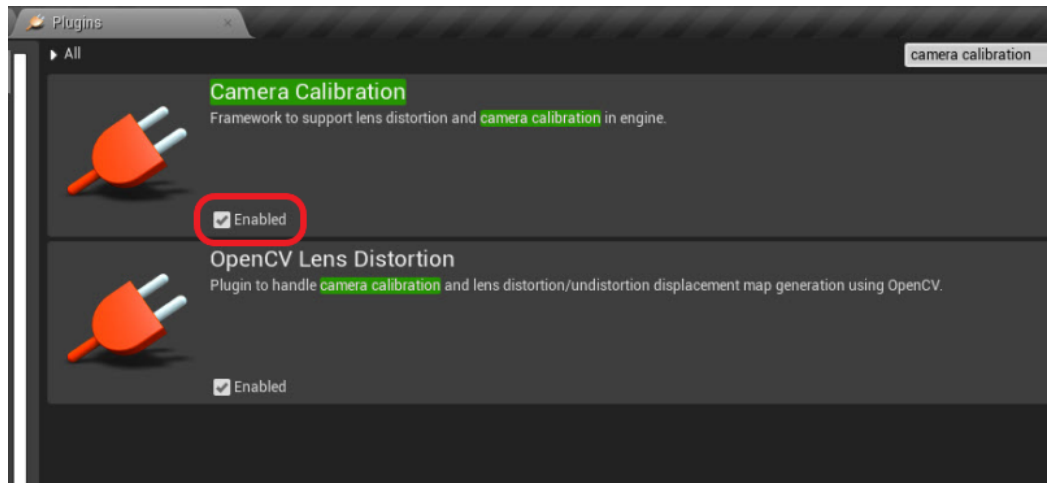

Restart Unreal Engine when prompted.

- 3. Right-click inside the **Content Browser** panel to open the context menu, then go to **Miscellaneous** and click **Lens File** to create a Lens File asset.

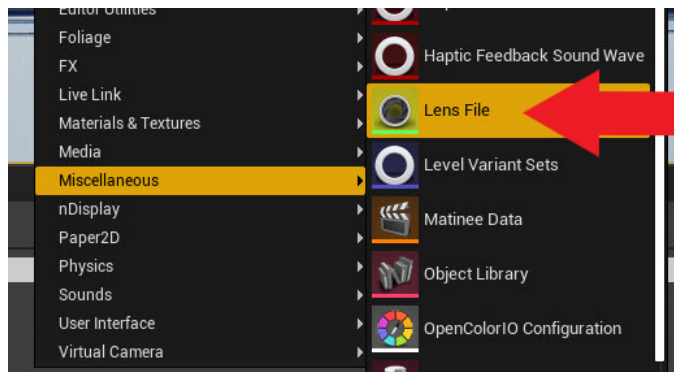

- In the **Content Browser** panel, double-click the Lens File asset to open the Lens File Asset Editor.

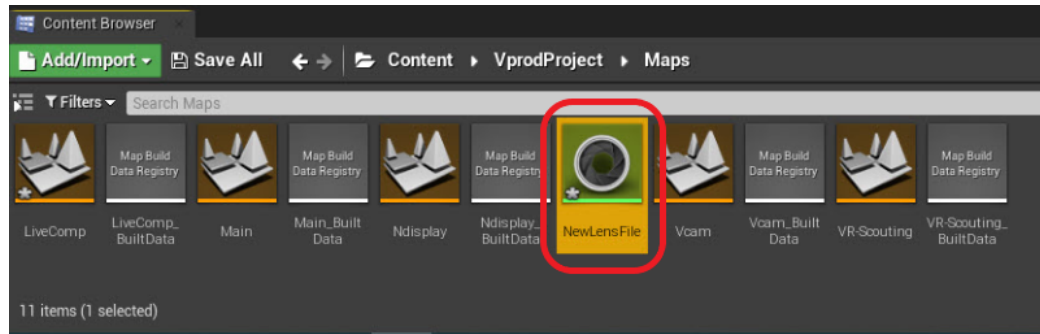

- Click the **Calibration Steps** panel and specify the **Sensor Dimensions** for your camera, then click **Save Lens Information**.

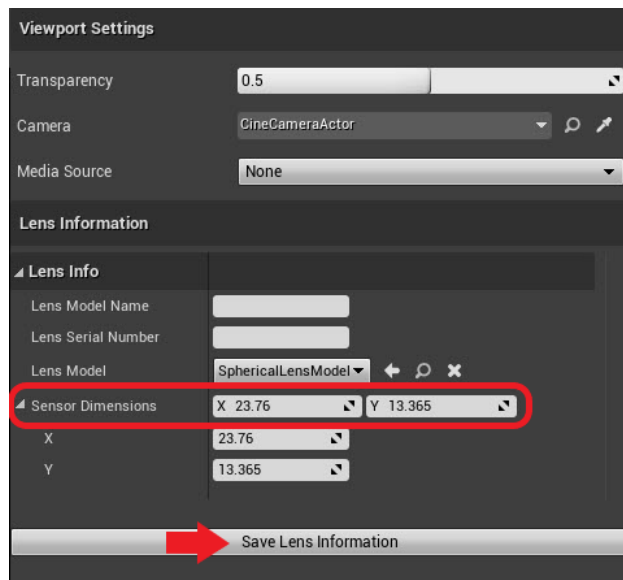
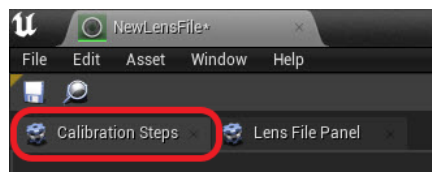

- Click the **Lens File Panel** and select **Focal Length**.

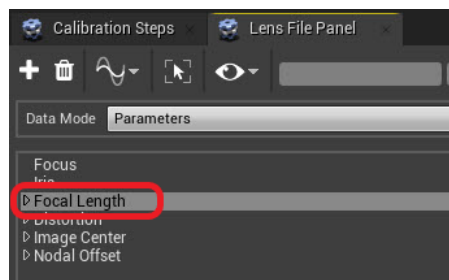

- Click the **+** button to open the Add Lens Data Point window, then enter the focal length values (Fx, Fy) from **Calibration_Result.txt** and click **Add**.

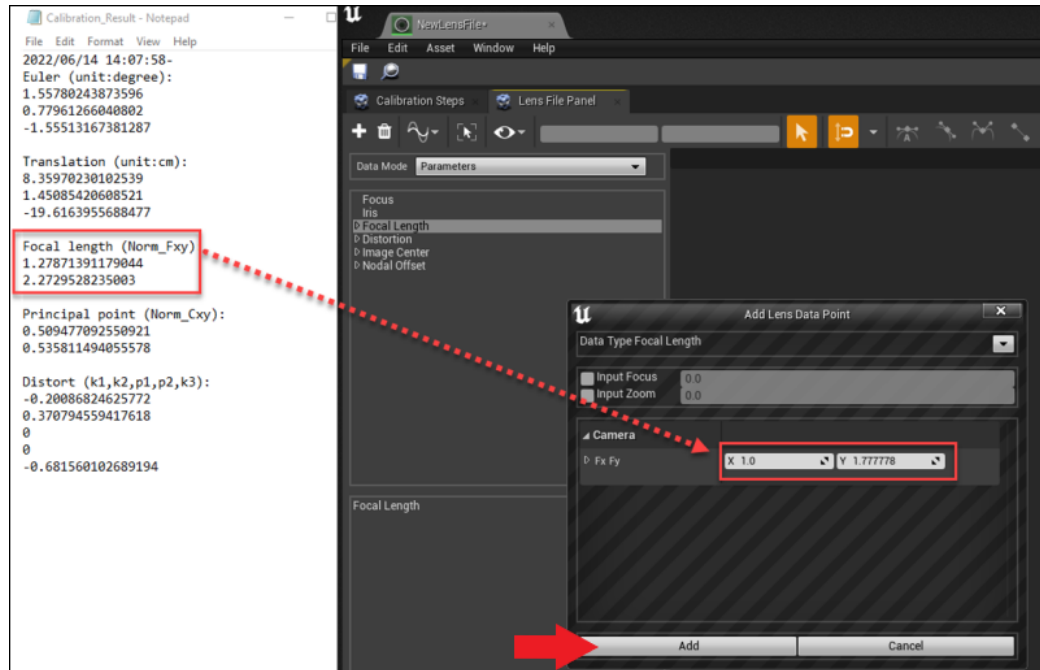

- Do the same for **Distortion**, **Image Center**, and **Nodal Offset**, and then click the **Save** button.

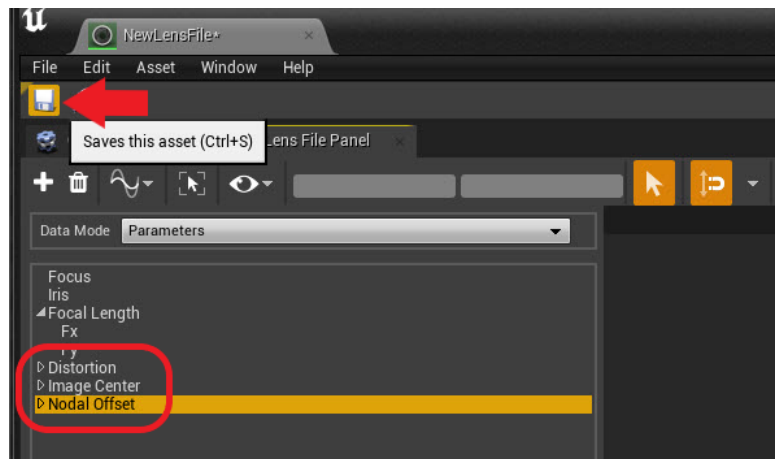

9. In the **World Outliner** panel, select your **CineCameraActor**.

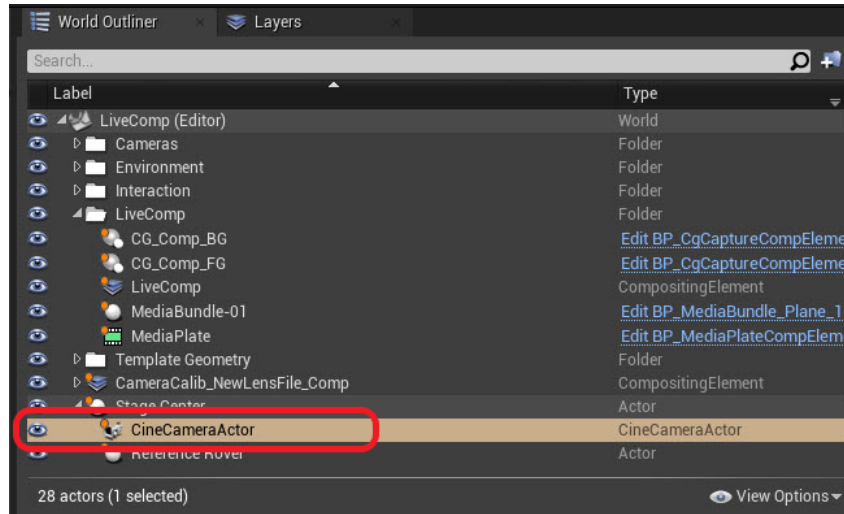

10. Go to the **Details** panel and select **LiveLinkComponent Controller**. Select **Live Link Camera Controller** as the **Camera Role** and then select your Lens File.

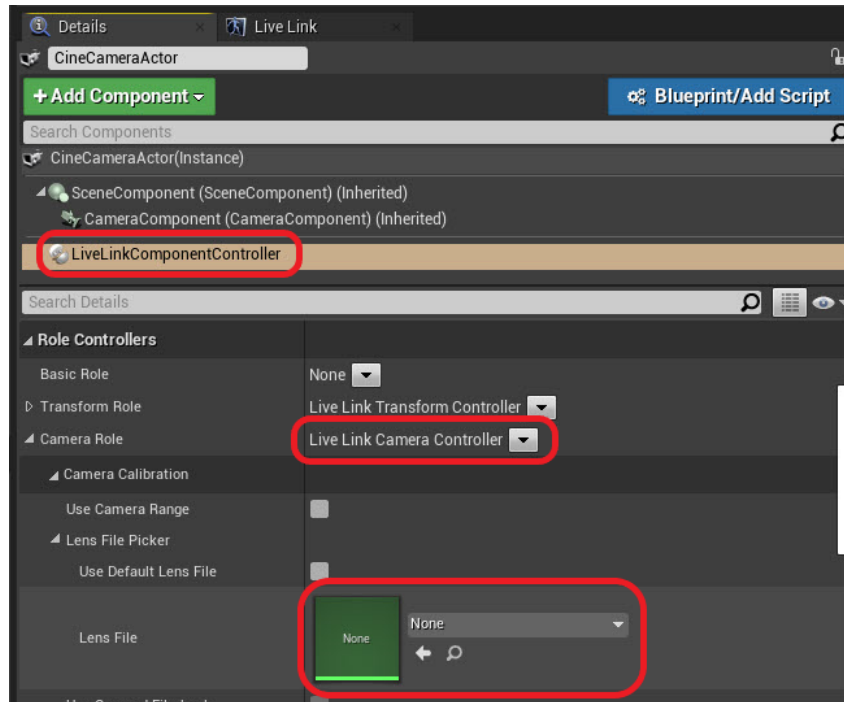

You can also drag and drop the Lens File asset from the **Content Browser** panel.

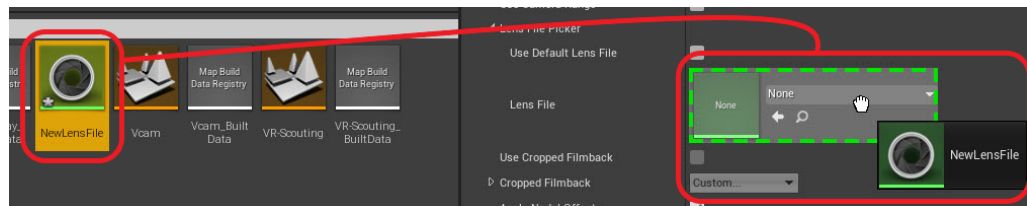

The calibration data will now be applied to the virtual camera.

Real-time compositing in Unreal Engine

Creating a project with a virtual production template

Create a project with a virtual production template to utilize virtual production components.

1. Launch Unreal Engine on your computer. The Unreal Project Browser will appear.
2. Select the category **Film, Television, and Live Events**.

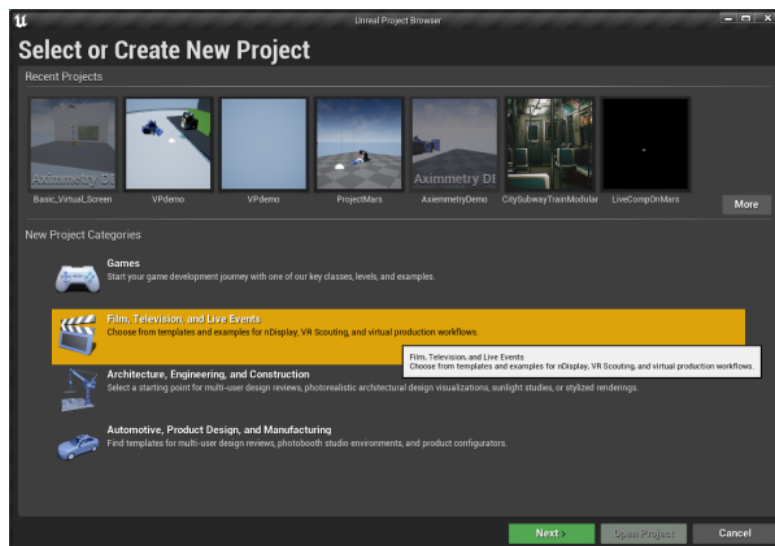

3. Select the template **Virtual Production**.

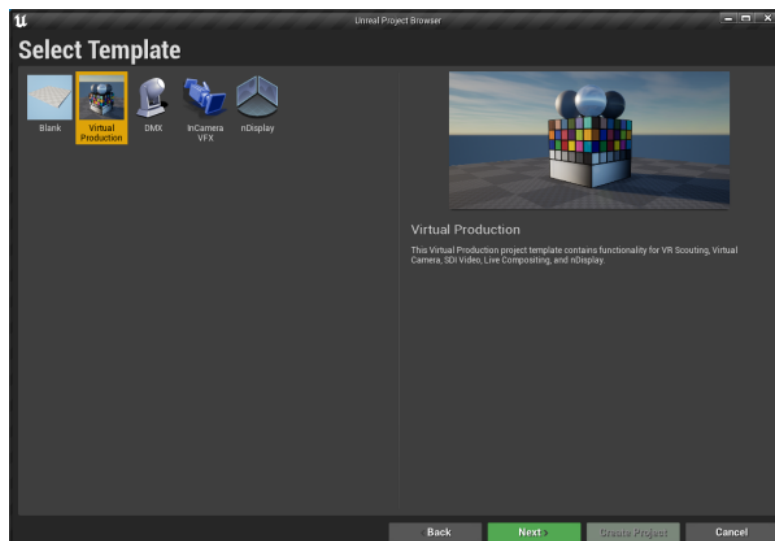

- On the Project Settings screen, select a destination folder for the project, and then click **Create Project**.

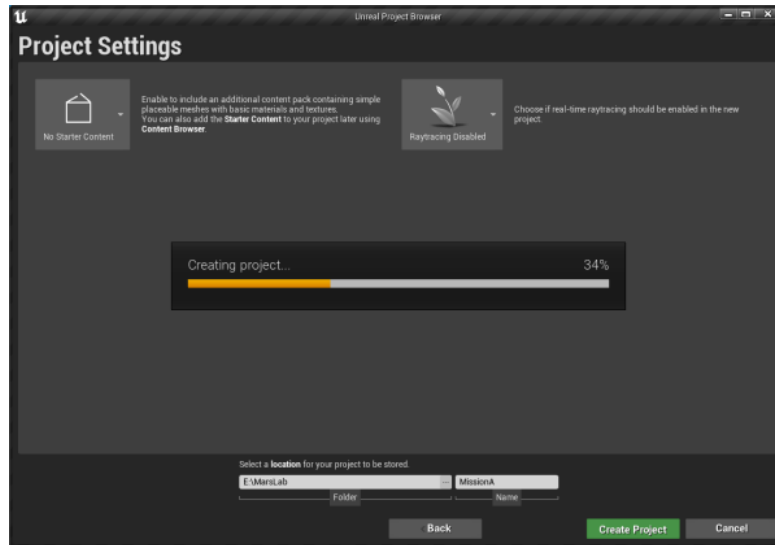

- In the **Content Browser** panel, go to **Content > VprodProject > Maps** and open **LiveComp**.

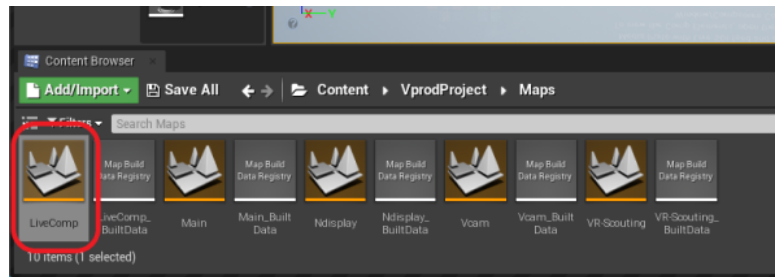

The **LiveComp** folder will appear in the **World Outliner** panel.

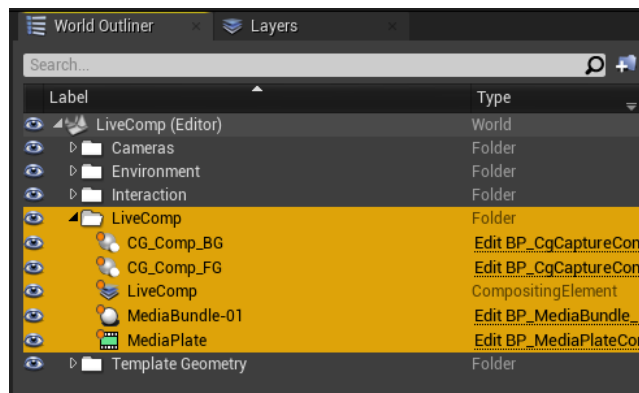

Connecting to Mars using the Live Link plug-in

After creating a project, you'll need to add Mars using the Live Link plug-in.

1. Open **Live Link** from the **Window** menu.

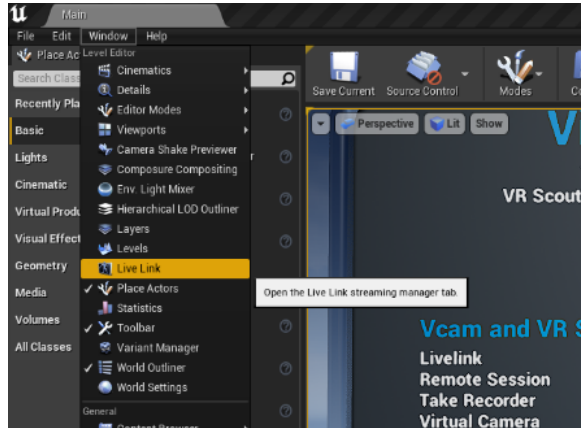

2. In the **Live Link** tab, click **+ Source**, then go to **Message Bus Source** and select the Mars source type.

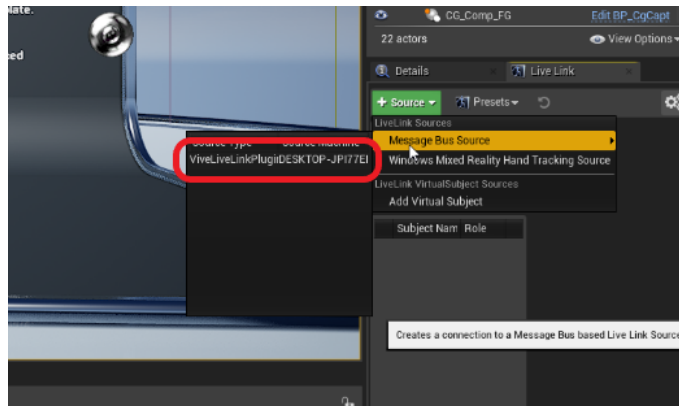

If Mars doesn't appear as an endpoint under **Message Bus Source**, you'll need to add it manually. See [Adding Mars as an endpoint in Unreal Engine](#) on page 20.

The Rover units connected to Mars will appear under Subject Name in the **Live Link** panel.

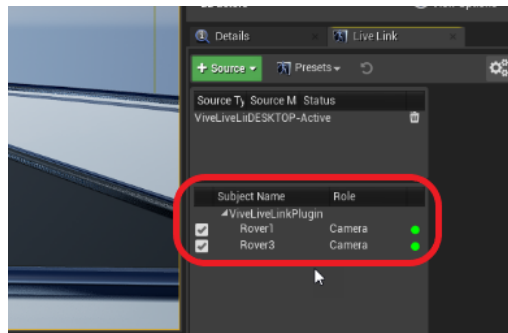

Setting up the virtual camera using the Live Link Controller

Here's how to set up your virtual camera in an Unreal Engine virtual production project.

1. In the **Place Actors** panel, go to the **Basic** tab, and then click and drag **Empty Actor** into your viewport to add it to your scene.

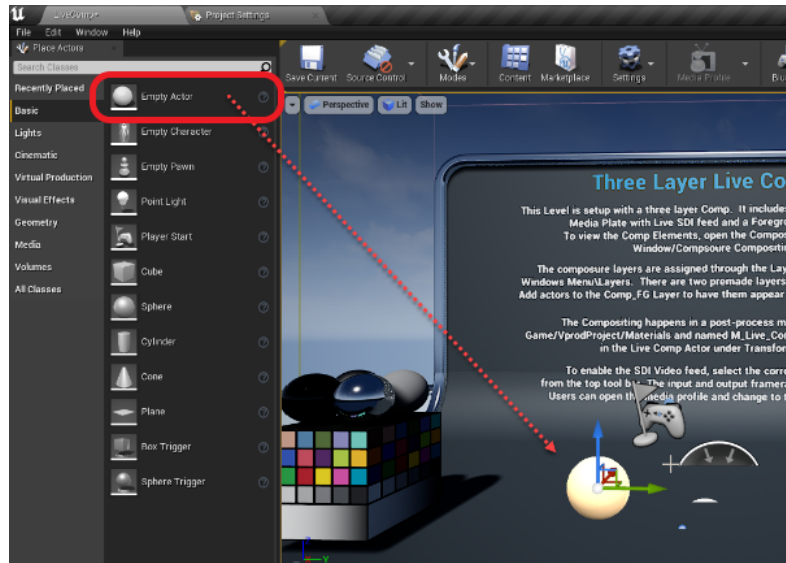

2. In the **World Outliner** panel, rename the empty actor to **Stage Center**.

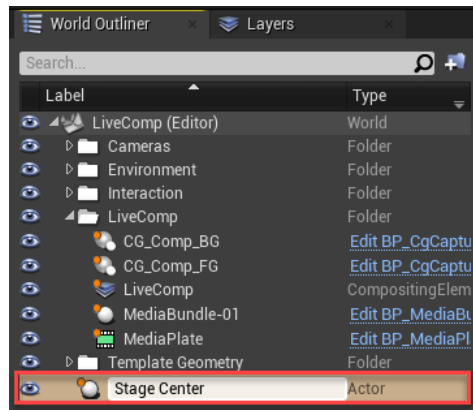

3. Set the **Location** and **Rotation** coordinates of the Stage Center actor to 0.

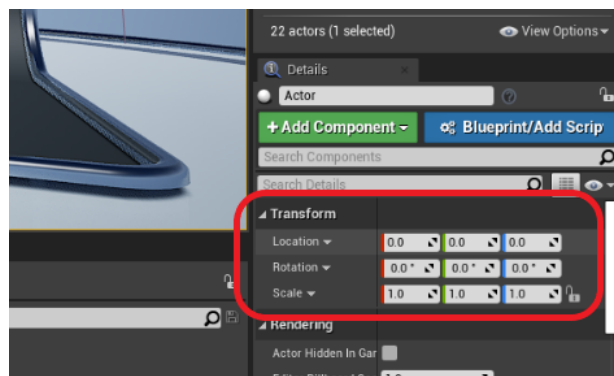

- Pull the Stage Center actor up through the floor of the viewport so it's fully visible.

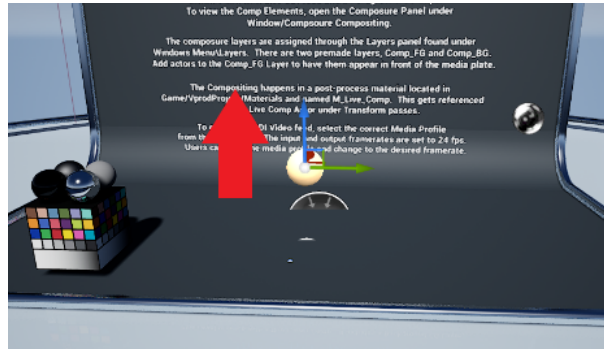

- In the **World Outliner** panel, drag the **Cine Camera Actor** under the Stage Center actor, and then set its **Location** and **Rotation** coordinates to 0.
- In the **World Outliner** panel, select **CineCameraActor**.

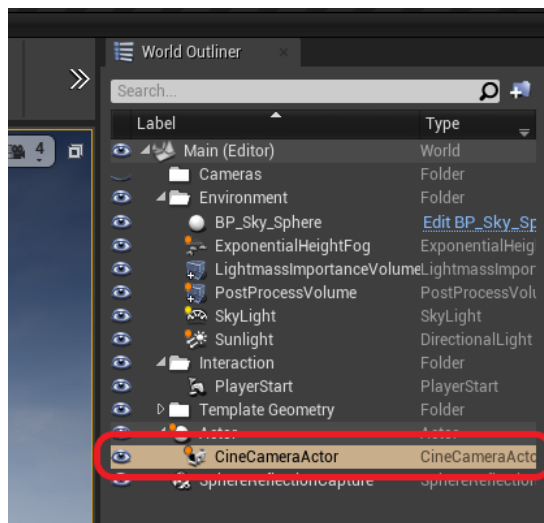

- In the **Details** panel, click **Add Component**, and then select **Live Link Controller**.

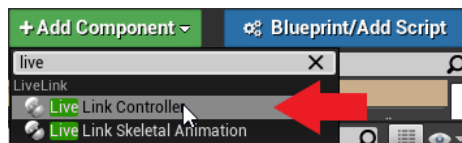

- Select **LiveLinkComponentController**.

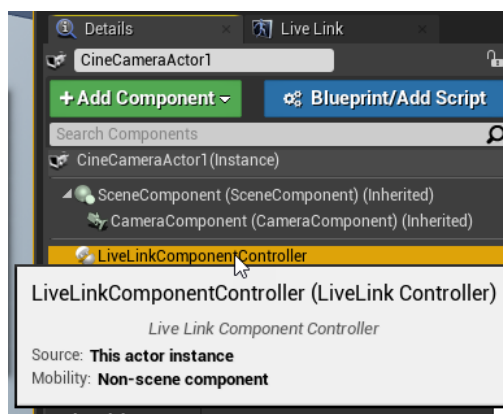

9. For **Subject Representation**, select **Rover 1**.

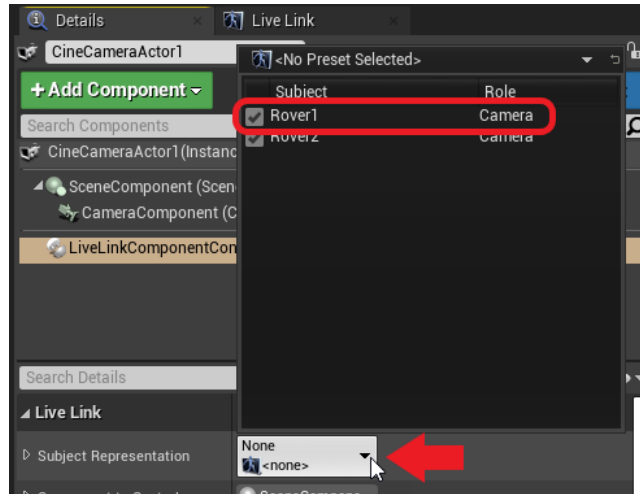

10. Place a Rover unit on your set in a stage center position with the VIVE logo facing away from the camera. Connect it to Mars, and then tap **Recenter** on the Mars dashboard.

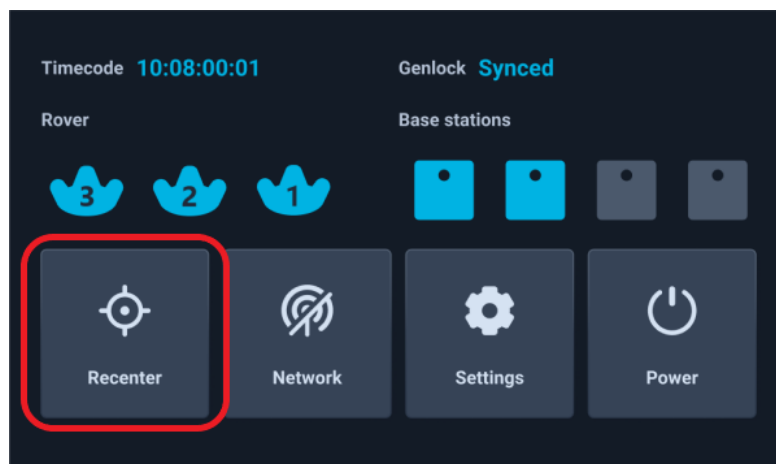

The **Location** and **Rotation** coordinates of **Rover 2** will be set to 0 and the actor **CineCameraActor (Rover 1)** will stay in the same relative position.

Configuring the media source using Composure

Here's how to configure the media source using Composure, the standard graphics utility plug-in for Unreal Engine.

1. In the **World Outliner** panel, select **MediaBundle-01**.

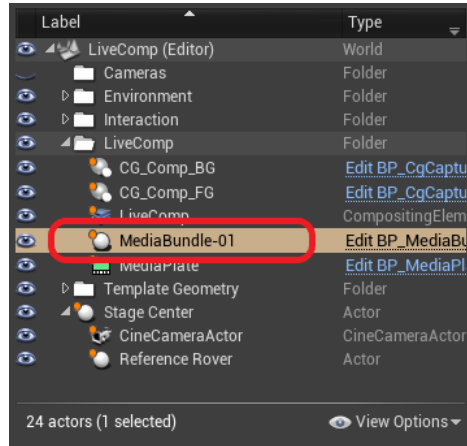

2. In the **Details** panel, double-click the icon under **Media Bundle** to open the configuration panel.

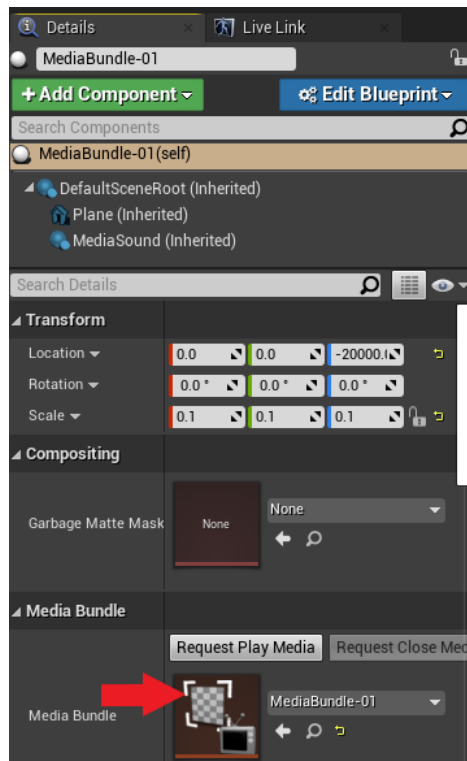

- For **Media Source**, select the media source associated with your video capture card. Make sure the settings are consistent with your camera's outgoing video feed.

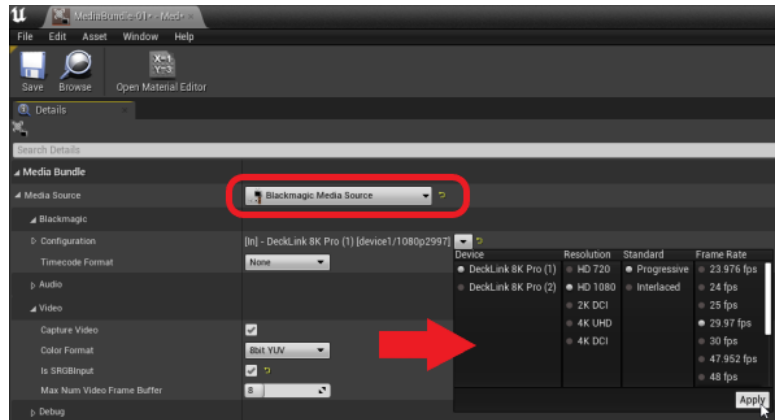

Remember to click **Apply** if you change any settings.

- Make sure **Is SRGBInput** is selected, and then click **Save**.

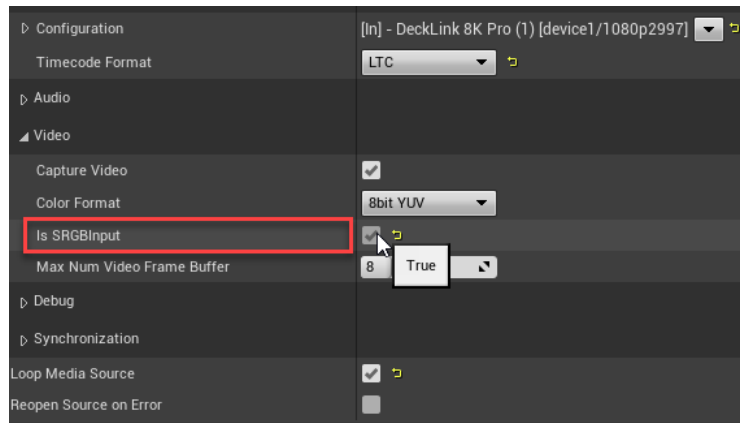

- In the **Details** panel, click the **Request Play Media** button under **Media Bundle**.

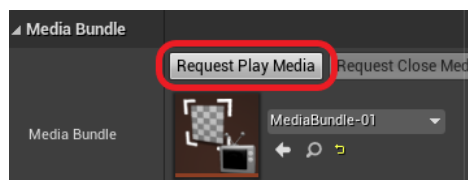

- In the **World Outliner** panel, select **MediaPlate**, and then select the texture **T_MediaBundle-01_BC** as the **Media Source** in the **Details** panel.

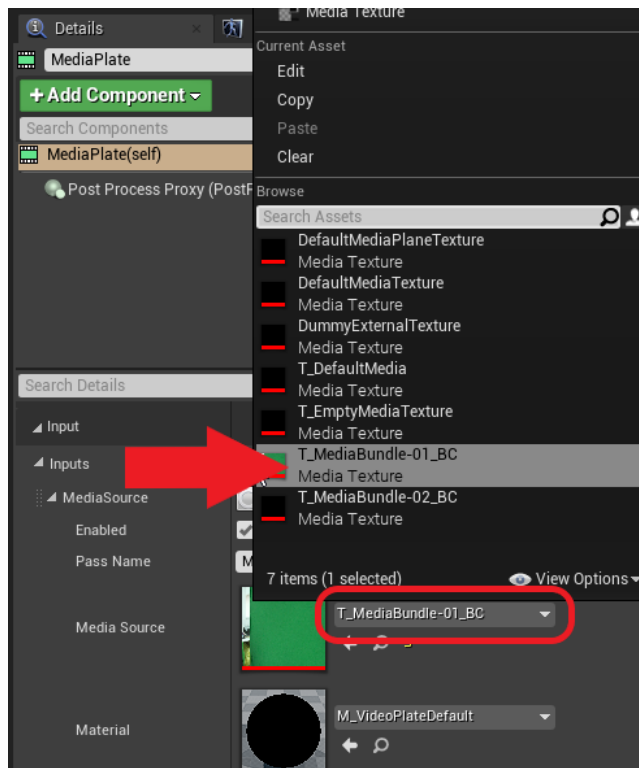

- Go to **Transform Passes > Chroma Keying > Key Colors**, click the **+** button to add a key color element, and then click the picker button to open the **Color Picker**.

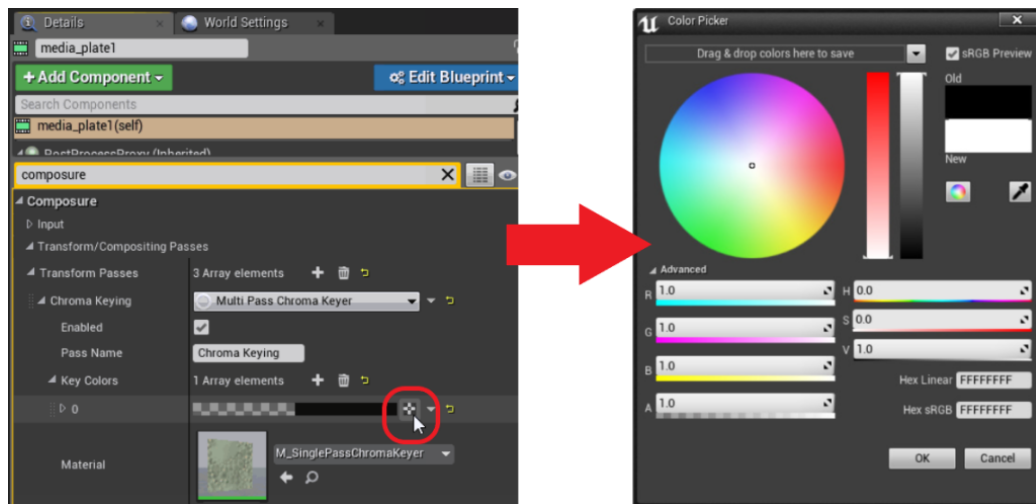

8. Select the correct green value, then use the **Eye Dropper** to add it to the **MediaPlate** preview.

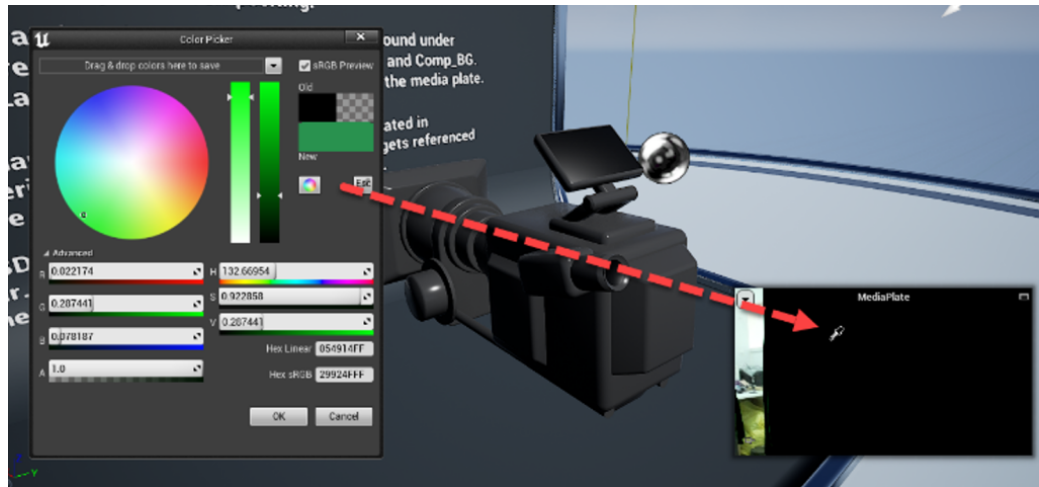

9. In the **World Outliner** panel, select the **LiveComp** element to view the results.

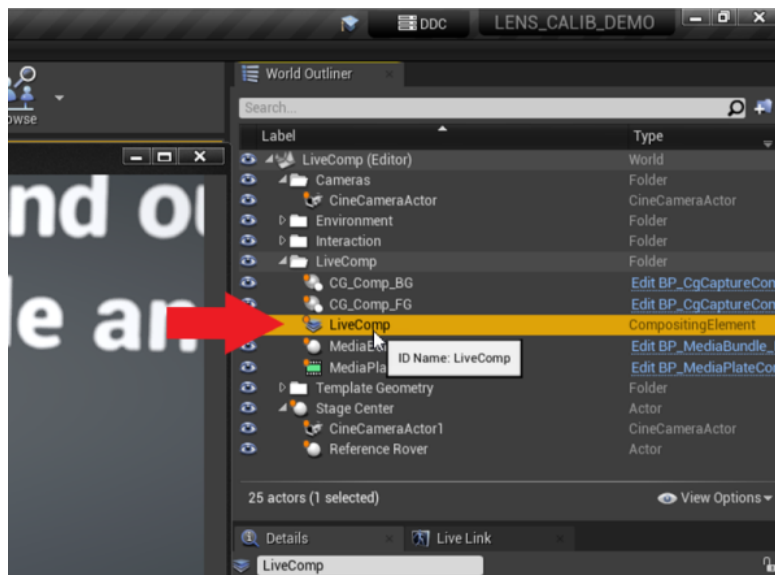

After configuring the media source, you're ready to import calibration data. For details, see [Importing calibration data into Unreal Engine](#) on page 29.

FAQs

How many base stations can I use?

You can use up to four base stations in a single VIVE Mars CamTrack setup with an area of up to 10 m x 10 m (32 ft 10 in x 32 ft 10 in).

You'll need to set up at least two base stations for minimum tracking coverage.

Can I use an odd number of base stations?

Yes. Each base station works independently of each other, and there is no pairing requirement among them.

Because at least two base stations are required for minimum tracking coverage and you can use a maximum of four base stations, the only possible setup with an odd number of base stations would have a total of three base stations.

Cleaning the base stations

Always keep the base stations and their power adapters dry and away from liquids to avoid shock hazard.

To clean the base stations:

- 1.** Unplug and unmount the base stations.
- 2.** Use a lightly moistened non-abrasive cloth to clean the base stations. Do not use cleaning chemicals.
- 3.** While cleaning the base stations, do not scratch the front panel nor disassemble any of its parts.

Can I use more than one VIVE Tracker (3.0)?

You can use up to three VIVE Tracker (3.0) units in a VIVE Mars CamTrack setup.

You'll need at least two VIVE Tracker (3.0) units for a basic VIVE Mars CamTrack setup—one for your camera, and one for the calibration board.

Why does VIVE Tracker (3.0) automatically turn off?

If VIVE Tracker (3.0) turns off by itself, it's most likely because the battery is drained.

Normally, VIVE Tracker (3.0) turns off after going idle or after pairing times out. However, when connected to Mars, VIVE Tracker (3.0) will never go idle or time out.

How do I verify that VIVE Tracker (3.0) is detected?

You can check the Mars dashboard to see if VIVE Tracker (3.0) is detected by Mars.

When VIVE Tracker (3.0) is detected, the VIVE Tracker (3.0) icon will flash blue. When the icon turns solid blue, VIVE Tracker (3.0) is detected and actively tracking.

What does the status light on VIVE Tracker (3.0) mean?

The status light on the tracker turns white or orange according to the following behaviors:

- **White:** VIVE Tracker (3.0) is working normally and fully charged.
- **Orange:** VIVE Tracker (3.0) is working normally and charging.

Why doesn't the VIVE Tracker (3.0) status icon on the Mars dashboard turn blue?

If the status icon doesn't turn blue, check that the Mars firmware is up to date.

Troubleshooting VIVE Tracker (3.0)

If VIVE Tracker (3.0) cannot be detected by Mars, try the following:

- Make sure that VIVE Tracker (3.0) is in the field of view of at least one base station.
- Turn VIVE Tracker (3.0) off and on again to reactivate tracking.
- Restart Mars.

Why can't I see the incoming video feed in the Camera Calibration Tool?

Depending on how your video capture device is configured, the Camera Calibration Tool might not display the incoming video feed.

If the Camera Calibration Tool doesn't display the incoming video feed after you select a video source, try reconfiguring your video capture device. For example, if you're using a **Blackmagic DeckLink 8K Pro**, you can resolve this issue by configuring the connector mapping as follows:

1. In the Blackmagic Desktop Video Utility, select your device, and then click the settings icon .
2. Click the **Connectors** tab.

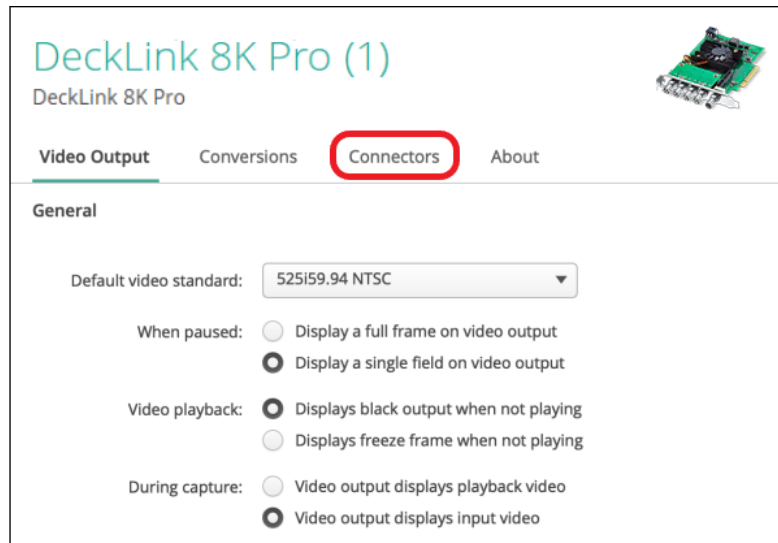

3. Under **Connector Mapping**, select one of the following for **Connector**:
 - **SDI 1 & 2 In, SDI 3 & 4 Out**
 - **SDI 1 In, SDI 2 Out**

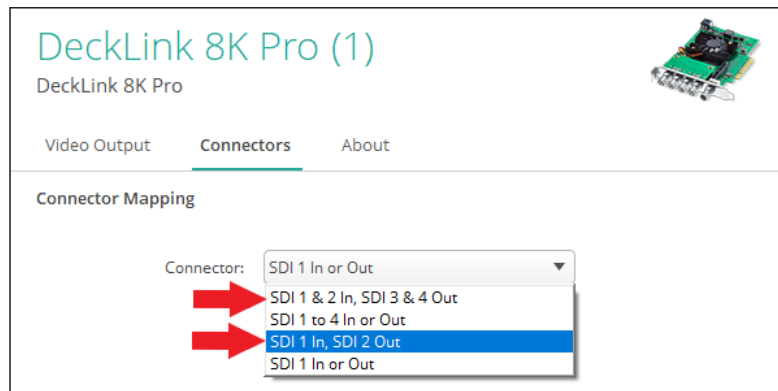

Trademarks and copyrights

©2022 HTC Corporation. All Rights Reserved.

VIVE, the VIVE logo, HTC, the HTC logo, and all other HTC product and service names are trademarks and/or registered trademarks of HTC Corporation and its affiliates in the U.S. and other countries.

Steam, the Steam logo and SteamVR are trademarks and/or registered trademarks of Valve Corporation in the U.S. and/or other countries.

All other trademarks and service marks mentioned herein, including company names, product names, service names and logos, are the property of their respective owners and their use herein does not indicate an affiliation with, association with, or endorsement of or by HTC Corporation. Not all marks listed necessarily appear in this User Guide.

Screen images contained herein are simulated. HTC shall not be liable for technical or editorial errors or omissions contained herein, nor for incidental or consequential damages resulting from furnishing this material. The information is provided “as is” without warranty of any kind and is subject to change without notice. HTC also reserves the right to revise the content of this document at any time without prior notice.

No part of this document may be reproduced or transmitted in any form or by any means, electronic or mechanical, including photocopying, recording or storing in a retrieval system, or translated into any language in any form without prior written permission from HTC.