



ROHM
SEMICONDUCTOR

Nano

Breakthrough energy savings
and miniaturization
ROHM Nano Power Supply Technologies

Nano Pulse Control™
Nano Energy™
Nano Cap™

Ver. 2.0

Creating Three Core Power Supply Technologies with the Goal of Becoming No.1 in Analog ICs

Higher voltages and frequencies

Enables direct step-down from 60V to 2.5V

Nano Second

Ultra-high-speed pulse control technology

Nano Pulse Control™



Lower current consumption

Enables 10-year drive on a single coin battery

Nano Ampere

Ultra-low current consumption technology

Nano Energy™



Greater miniaturization • Reduced design load

Eliminates stability issues related to capacitance

Nano Farad

Ultra-stable control technology

Nano Cap™



Nano Pulse Control™, Nano Energy™ and Nano Cap™ are trademarks or registered trademarks of ROHM Co., Ltd.

A pioneering project promoted by engineers with challenging spirit brings new core technologies

In 2014 a new project emerged within the IC development department to develop power supply IC technologies. Power supply ICs occupy an important position at ROHM, and at the time ROHM was improving the technologies from a product development perspective by improving the performance required for different applications. This new project was started with the objective of establishing novel core technologies for power supply ICs aligned with superior product development by leveraging ROHM's vertically integrated production system to thoroughly pursue not only circuit and layout design, but also process technologies. ROHM was able to create three new power supply technologies through trial and error by a leader with a wealth of experience and achievement in power supply IC and engineers eager to take on new challenges recruited from within the company.

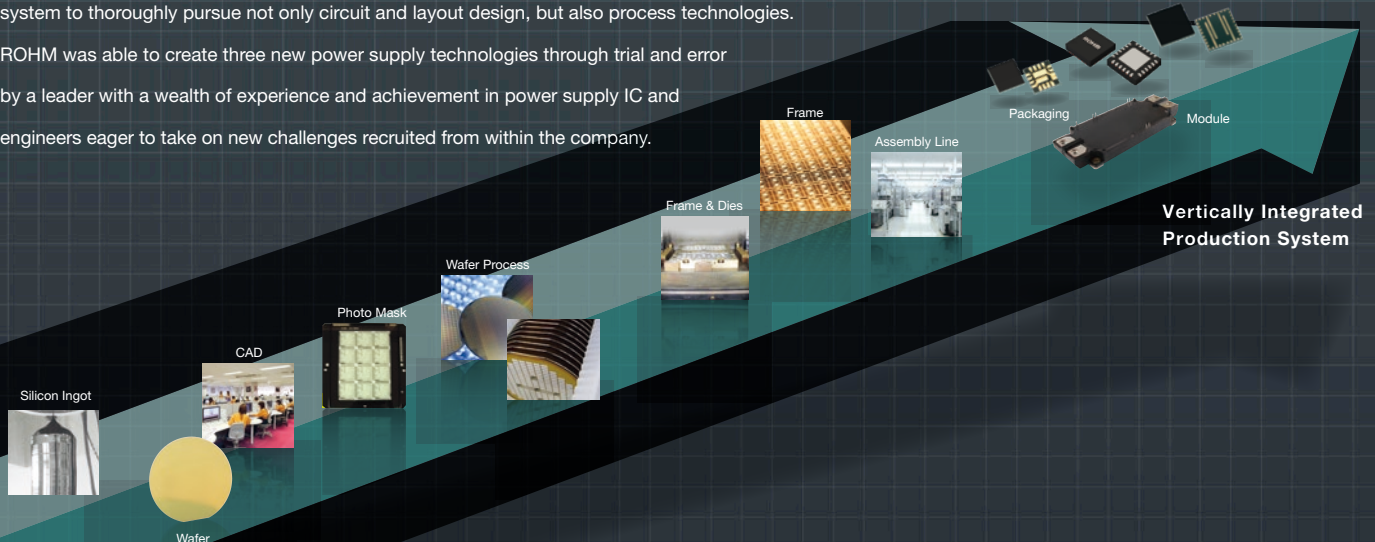
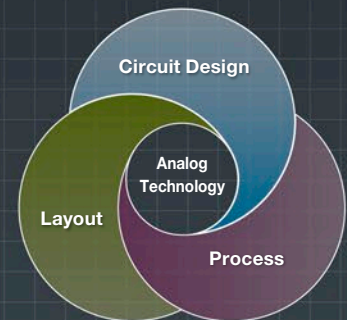

Electronics for the Future

Becoming a company that solves social issues through electronics

Pursuing the limits of power supply ICs

These three new technologies achieve superior specifications on the minimal unit of nano (10^{-9}).

The first technology is ultra-high-speed pulse control technology Nano Pulse Control™ that provides circuit control with a switching ON time (control width of the power supply IC) in nanoseconds (ns), making it possible to convert from high to low voltages using a single IC - unlike conventional solutions requiring two or more power supply ICs.

The second technology, ultra-low current consumption technology Nano Energy™, achieves quiescent current on the order of nano ampere (nA) by minimizing current consumption at ultra-low loads and trade-off coming from reducing current consumption, contributing to extending the operating time of mobile devices.

The third technology, Nano Cap™ ultra-stable control technology established in 2020, supports the order of nano farad (nF) output capacitances 10x smaller than conventional capacitances, ensuring extremely stable operation even when the input voltage or output load current fluctuates. Eliminating capacitor issues in analog circuits reduces not only capacitance but also the design resources required.

As a company dedicated to solving social issues through electronics, ROHM incorporates these technologies in power supply and analog ICs to provide solutions of energy efficiency and miniaturization to the market. In addition, ROHM is pursuing further technological development to find extreme solutions that can be applied to power supply ICs and semiconductors to achieve a sustainable society through the effective use of resources and reducing environmental impact.

Solutions Required by Applications

- Power saving (longer application life)
- High power compatibility
- Stable operation
- Higher functionality (including greater miniaturization)
- Safety functions

Solutions Power Supply ICs Can Provide

- High power conversion efficiency, low current consumption
- Higher withstand voltage, large current support
- Fast response
- High integration, fewer peripheral components/ greater miniaturization
- Protection functions, long-term operation (high reliability)

Nano Pulse Control™



- Supports greater miniaturization by enabling step-down from 60V (Max) to 2.5V
- Drives GaN devices with 2ns pulse control

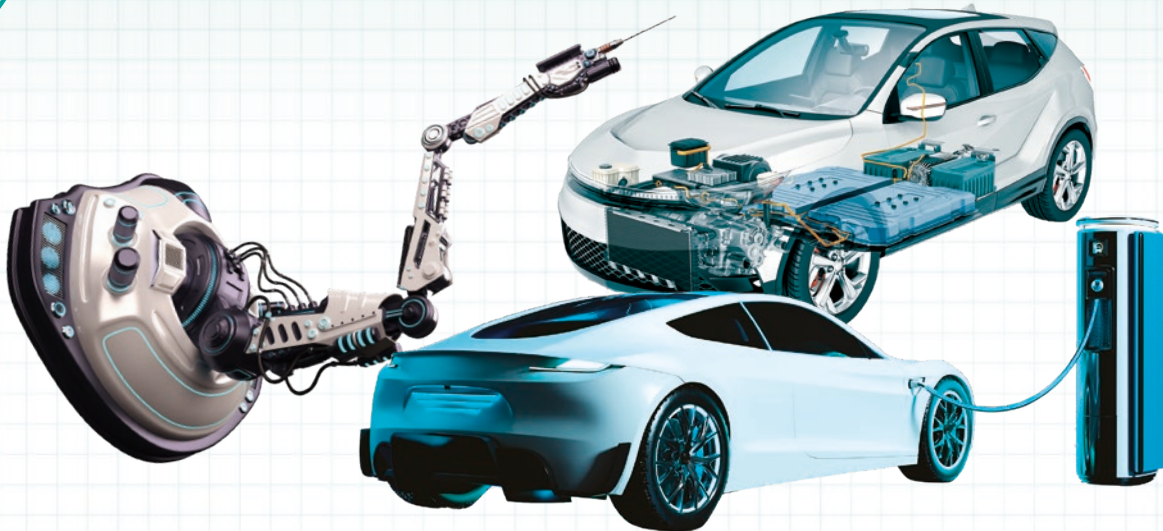

Development Background

Every electronic device must pursue lower power consumption to improve cost efficiency, and can not accept limitless increasing power consumption for increasing performance and functionality. Along with this, power supply systems that handle large amounts of power are trending towards higher voltages to reduce power loss during transmission, while in MCUs that control electronic circuits, the transistor drive voltage is being reduced to reduce internal power consumption in line with chip miniaturization.

In power supply systems (DC-DC converters) that use 48V, such as mild hybrid vehicles and industrial robots, where it is necessary to step down the voltage from 48V to the 3.3V or 2.5V required by the MCU, or in automotive applications that requires voltage conversion with a high step-down ratio at 2MHz or higher switching operation to avoid AM radio interference, it was common to step-down in two steps (two chips) by first dropping the voltage to an intermediate voltage of 12V.

What's more, as 48V systems require voltage step-down from a maximum of 60V to as low as 2.5V after considering margin, stepping down in a one chip must achieve a high step-down ratio of 24:1 which entails shortening the switching ON time of the power supply IC to 20ns (thinner pulses).

Technology Formation and Solutions

ROHM took on the challenge of 'single-chip' DC-DC converter systems by moving away from conventional thinking to develop a unique circuit architecture that enables ultra-high-speed control. At the same time, ROHM has established ultra-high speed pulse control technology Nano Pulse Control™ by taking advantage of a vertically integrated production system that includes high voltage BiCDMOS processes. This technology has succeeded in shortening the switching ON time to as low as 9ns, which in 2016 was the industry's lowest value for DC-DC converter ICs. Considering that the lowest ROHM could achieve at that time was 120ns, this proved to be groundbreaking technology. Another key point is the ability to provide stable control and protection circuitry at this extremely narrow pulse width.

Overview of Nano Pulse Control™ Technology

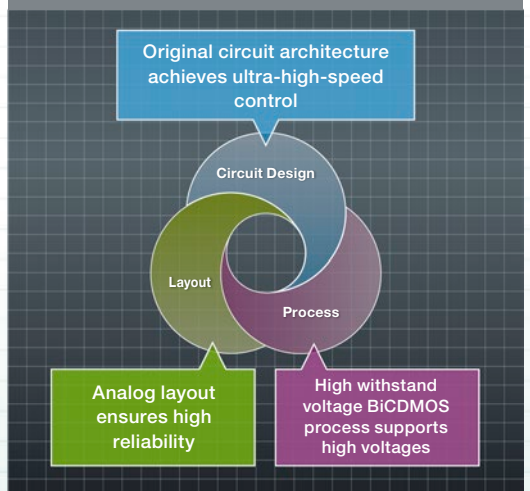

Nano Pulse Control™ Technology Solutions

System Configuration Comparison

Conventional System Configuration

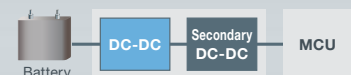

System Configuration with Nano Pulse Control™ Equipped DC-DC



Contributes to dramatically smaller, simpler systems



Typical Specifications and the Future

With the establishment of Nano Pulse Control™ technology, it is now possible to not only step down from a maximum of 60V to 2.5V at 2MHz switching required in the automotive field, but also from 5V to ultra-low voltages of 1V or less necessary for advanced SoCs with a single chip power supply IC. Compared with 2-chip buck power supply solutions, the number of components, including peripherals, can be significantly reduced, contributing to lower costs through miniaturization and system simplification in a wide range of applications such as industrial robots, base station sub power supplies, and 48V mild hybrid vehicles. ROHM is further refining its Nano Pulse Control™ technology to control high-speed, low-loss GaN devices.

Effects of Nano Pulse Control™

DC-DC Converter IC Pulse Width Comparison (High Voltage Products for Automotive and Industrial Equipment)

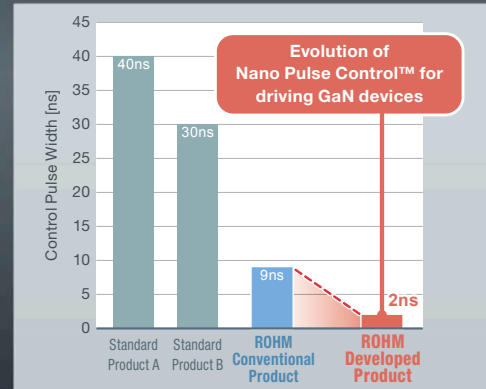

Achieves ultra-speed pulse control in the high frequency range

Topic

ROHM Establishes Ultra-High-Speed Control IC Technology that Maximizes the Performance of GaN Devices



ROHM Establishes Ultra-High-Speed Drive Control IC Technology that Maximizes GaN Device Performance

While the adoption of GaN devices has expanded due to their superior high-speed switching characteristics, the speed of control ICs, which are responsible for directing the driving of these devices, has become an issue. In response, ROHM has further evolved Nano Pulse Control™, succeeding in significantly improving the control pulse width from the conventional 9ns to an industry-best* 2ns. This has led to the establishment of ultra-high speed drive control IC technology that maximizes the performance of GaN devices. ROHM is currently developing 100V input voltage 1ch DC-DC controller ICs using this technology.

Power Supply Solution Using GaN Devices and Nano Pulse Control™ Technology

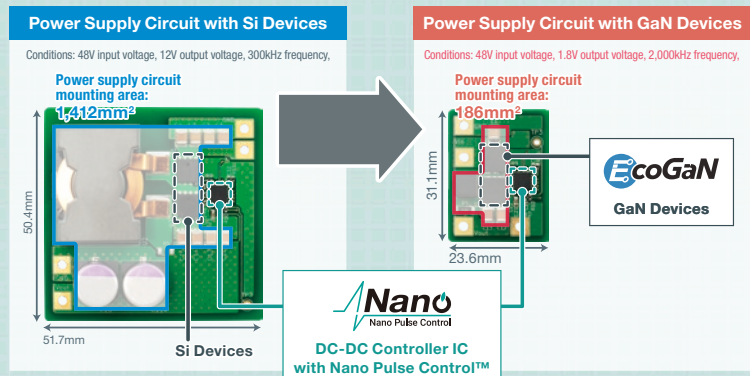

Reduces power supply circuit mounting area by 86%, enabling dramatic miniaturization

*ROHM March 2023 study

*EcoGaN™ is a trademark or a registered trademark of ROHM Co., Ltd.

Nano Energy™



- Ultra-low current consumption enables 10-year drive on a single coin battery
- BMS solution with state-of-the-art rechargeable batteries



Development Background

The use of high-performance smartphones, wearables, and various IoT devices continue to increase in homes, factories, and other locations and fields. Not only is there a strong demand to minimize power consumption in the systems of these battery driven devices, but reducing size in consideration of space allocation becomes a critical requirement when incorporating new features and improving design.

As a result, batteries are becoming smaller and denser, while in the IoT field there are many cases where equipment maintenance cannot be regularly performed. Around 2015 a key phrase in the IoT field was ‘10-year operation on a single coin battery’.

To address this issue, ROHM began developing technology to significantly reduce current consumption, an important specification for power supply ICs. When development started in 2015, one of the indicators was how far we could go below 360nA, which at the time was the lowest current consumption in the power IC industry.

Technology Formation and Solutions

Reducing current consumption can be achieved by simply increasing the resistance value of the circuit, but this can cause problems such as generating leakage current in the element, increasing noise sensitivity, and degrading the response characteristics of the circuit.

ROHM established Nano Energy™, an ultra-low current consumption technology that significantly lowers the benchmark of 360nA by minimizing the trade-offs associated when lowering current at ultra-light loads. As the first product incorporating this technology, the BD70522GUL buck DC-DC converter IC achieves an ultra-low current consumption (quiescent current) of 180nA that enables 1.4x longer battery life during no-load compared to conventional products under specific conditions. This was only made possible by integrating three analog technologies covering circuit design, layout, and processes using ROHM’s vertically integrated production system.

Overview of Nano Energy™ Technology

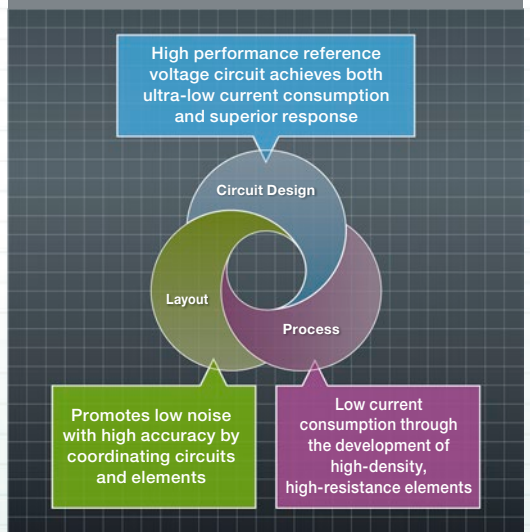

Nano Energy™ Technology Solutions

Comparing Application Run Time Using a Coin Battery

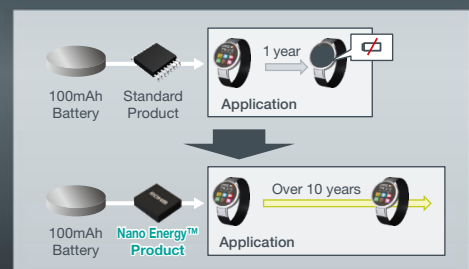

Dramatically extends application run time



Typical Specifications and the Future

Beginning with the establishment of Nano Energy™ technology, ROHM has achieved ultra-low power supply solutions for the IoT field by significantly reducing the current consumption of power supply ICs. This not only reduces the time and costs required to maintain IoT devices, but also extends the operating time when using small batteries in electronic devices such as wearables that are becoming increasingly sophisticated and compact. What's more, it is now possible to keep the power supply operating even with a small amount of power generated from environmental sources such as sunlight, heat, and vibration.

ROHM is expanding Nano Energy™ as a core technology for low current consumption not only to power supply ICs, but also to internal power supplies for other products such as reset ICs and op amps, contributing to extending operating times in various battery-driven applications.

Effects of Nano Energy™

Comparison of Quiescent Current of Buck DC-DC Converter ICs in Equivalent Application
($V_{IN}(\text{Max})=5.5\text{V}$, $I_{OUT}(\text{Max})=500\text{mA}$)

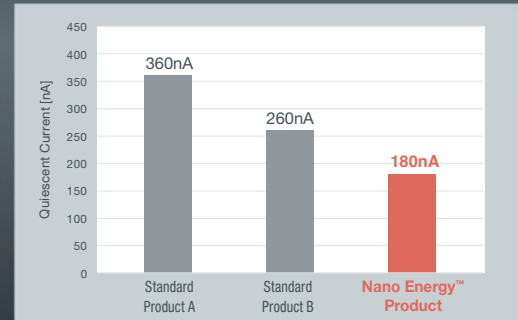

Topic

Battery Management Reference Design for Advanced Rechargeable Batteries

Nano Energy™ technology is ideally suited for energy harvesting using solar cells and state-of-the-art rechargeable batteries. ROHM is working with battery manufacturers to strengthen the development and supply of reference designs for battery management systems (BMS) in IoT devices. One example is the REFLVMS00x reference design that consists of a power supply IC equipped with Nano Energy™ along with the most advanced batteries from various battery manufacturers, resulting in an ultra-low power supply solution that also includes a charge control IC for managing the charging, monitoring, and discharging of the batteries to achieve an ultra-high efficiency energy storage unit. A voltage detector (reset IC) is mounted as well to detect anomaly voltages utilizing Nano Energy™ for ultra-low quiescent current, providing efficient power supply functions for user applications.

Overview of ROHM's Nano Energy™ Battery Management Solution

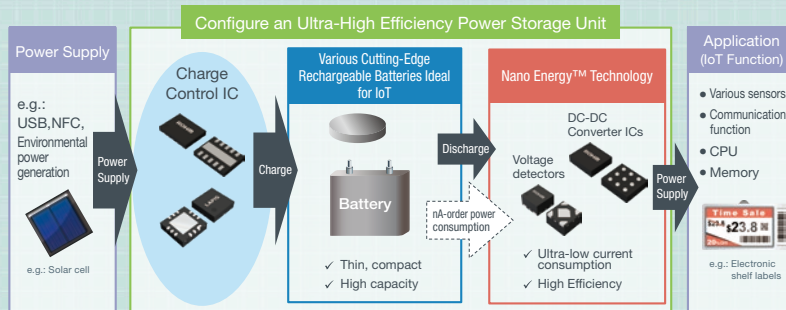

Provides efficient power supply functions for applications by minimizing loss

Battery Management Reference Design

(Collaboration with Maxell, Ltd.'s All-solid-state Battery)

General-Purpose Solution

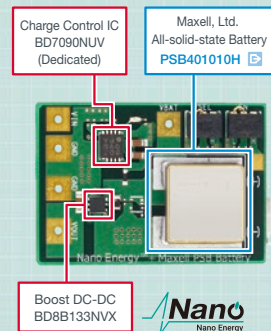

REFLVMS002-EVK-001

Solution for Energy Harvesting

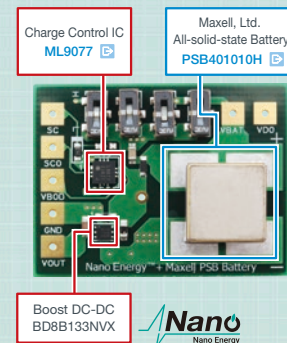

REFLVMS003-EVK-001

➔ REFLVMS002: Maxell's All-solid-state Battery × Nano Energy™ Collaboration Board

➔ REFLVMS003: All-solid-state Battery Charging Solution Board for Energy Harvesting

Nano Cap™



- Eliminates stability issues related to capacitance
- Another proprietary technology for achieving high-speed load response

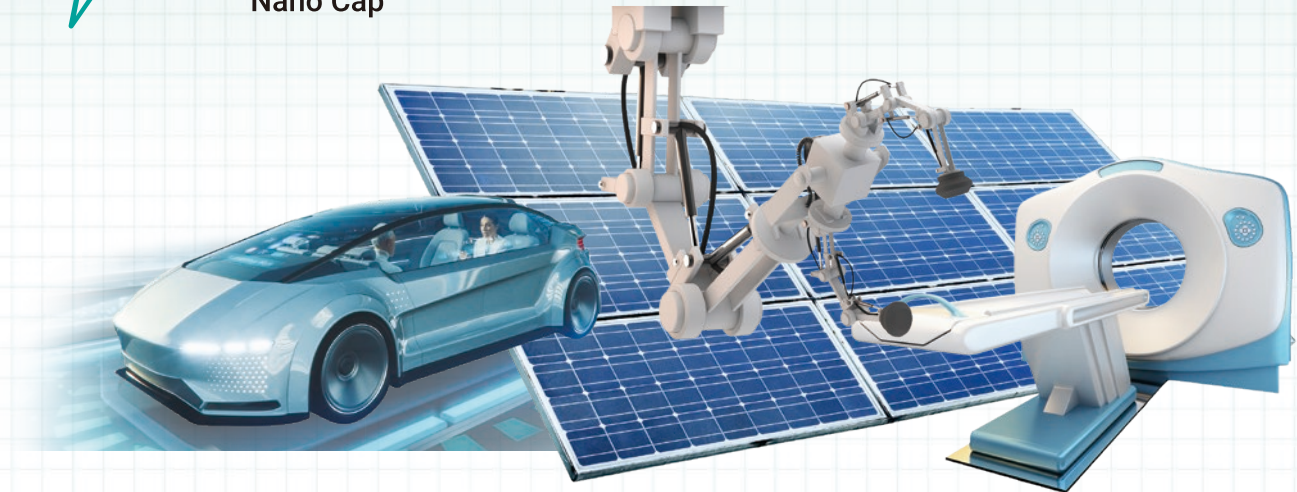

Development Background

As the number of electronic components continues to rise following the electrification of devices in all fields, the effective use of resources and reducing environmental impact have become major issues on a global scale. In the automotive field in particular, as technological innovations in electric vehicles and automated driving increase the number of electronic components, there is a growing demand to reduce the number of capacitors that are often used to stabilize electronic circuits as many as possible.

To address this issue, power supply circuits are requiring power supply ICs (LDO regulators) that can operate even with small output capacitors, but reducing capacitance increases the risk that the output voltage of the IC will become unstable and oscillate in response to input or load variations. As such, achieving stable operation required by applications (e.g. limiting output voltage fluctuations to within $\pm 5\%$ during load fluctuations) is possible down to $1\mu\text{F}$, but to ensure stable operation in the nF range and below an unprecedented technological breakthrough was necessary.

Overview of Nano Cap™ Technology

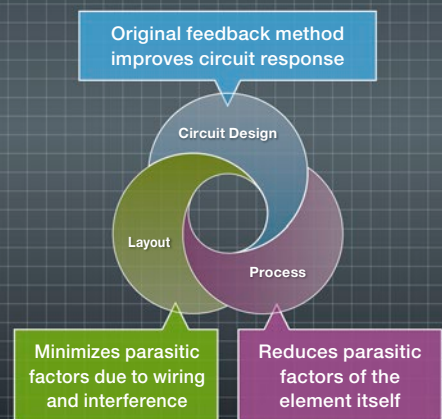

Technology Formation and Solutions

Nano Cap™ technology utilizes a unique feedback method to provide stable control of LDO regulator output by improving response in analog circuits while minimizing parasitic factors related to wiring and the amplifier, making it possible to reduce the output capacitance to less than 1/10th over conventional solutions.

For example, in the case of a circuit comprised of an LDO regulator and MCU, a $1\mu\text{F}$ capacitor is generally required at the output of the LDO and 100nF at the input of the MCU, but with Nano Cap™ technology stable operation can be achieved using just a 100nF capacitor at the MCU side. What's more, even when high circuit reliability is required, such as in automotive applications, stable operation is possible by reducing the output capacitor of the LDO to around 100nF (much less than $1\mu\text{F}$). This not only decreases the size of components and substrates, but also reduces the number of design resources by supporting a wider range of capacitances.

Nano Cap™ Technology Solutions

Capacitance Required for Stable Operation Against Load Fluctuations In Power Supply ICs

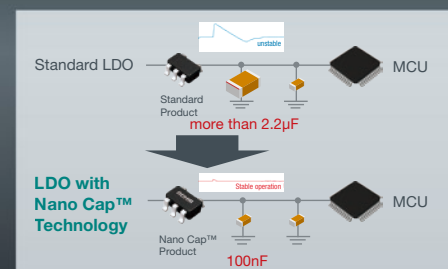

Combines a high level of capacitance reduction with stable operation



Typical Specifications and the Future

Incorporating Nano Cap™ ultra-stable control technology in the BD9xxN1 series of LDOs enables support for output capacitances as low as 100nF, which is less than 1/10th that of general products, ensuring stable operation required by applications (output voltage variation within 100mV: 1mA ↔ 50mA/1μs load current fluctuation) even when the input voltage or load current fluctuates.

This provides compatibility with a wide range of output capacitors, including not only common μF-order compact MLCCs (Multi-Layer Ceramic Capacitors) and large capacitance electrolytic capacitors, but also ultra-compact MLCCs down to 1μF or less in the 0603 size which were previously not stable enough and couldn't withstand actual use.

ROHM is further accelerating product deployment of Nano Cap™ technology established in 2020 to solve stability issues related to capacitors in various analog circuits by deploying in the internal circuitry of LDO regulators, Op Amps, and other products.

Effects of Nano Cap™

Comparison of Stable Operation in Automotive LDO Regulators (150mA) (Graphs of Response Performance to Load Current Fluctuation)

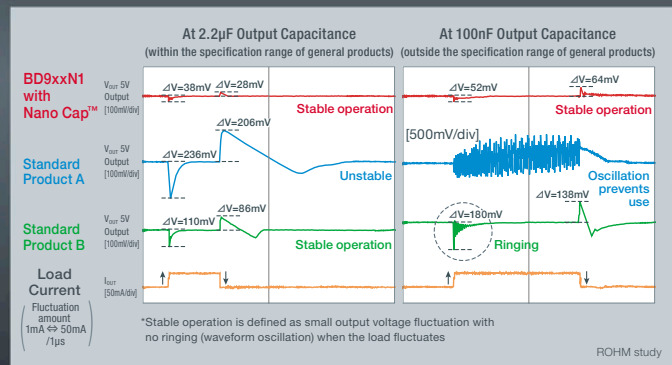

Ensures stable operation with a wide range of capacitances from minimal 100nF

Column

ROHM Establishes QuiCur™, an Innovative Power Supply Technology that Maximizes the Response Performance of Power Supply ICs

Nano Cap™ provides ultra-stable control of output by improving response in analog circuits while minimizing parasitic factors related to wiring and amplifiers. In this case, QuiCur™ high-speed load response technology is also utilized to reduce output capacitance to 100nF, less than 1/10th that of conventional, while maintaining stable operation. QuiCur™ is named after ROHM's original 'Quick Current' circuit that makes it possible to maximize load response characteristics without causing instability in the feedback circuits of power supply ICs. By expanding the stable control range in power supply IC feedback circuit with Nano Cap™ and achieving extreme response performance using QuiCur™, we have succeeded in developing LDOs that enable stable operation on the nF order which was not possible in the past.

Technical Combination of QuiCur™ and Nano Cap™ (Frequency Characteristics Described by Bode Plot)

f_c : Zero cross frequency, index of response performance
 f_{pc} : Change point determined by the output capacitor C_{out}

QuiCur™ High-Speed Load Response Technology

Eliminates the unusable area while allowing the zero cross f_0 to be set at the limit of the unstable area

Nano Cap™ Ultra-Stable Control Technology

The stable control area can be extended to higher frequency bands

QuiCur™ High-Speed Load Response Technology

Eliminates the unusable area while allowing the zero cross f_0 to be set at the limit of the unstable area

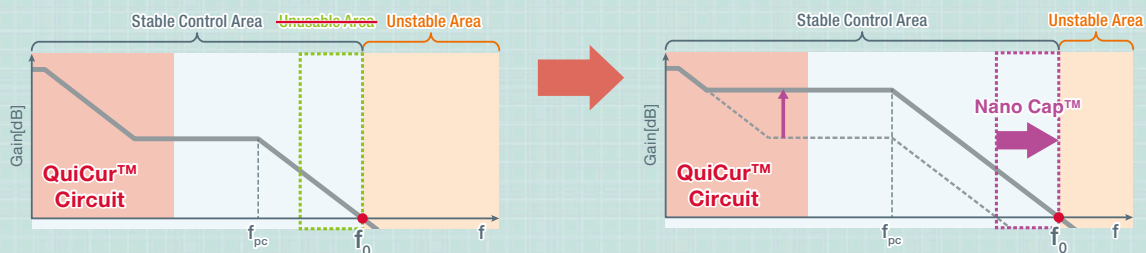

Leveraging technologies minimizes capacitance while achieving extreme response performance

HIGHLIGHT PRODUCTS

☆: Indicates that the product is under development as of the date of publication (July 1, 2023)



Nano Pulse Control™ Technology Product Lineup

DC-DC Converter ICs: Buck Type with Built-in FET (V_{IN}=36V or higher for primary power supplies)

Part No.	Input Voltage Maximum Rating [V]	Input Voltage [V]	Output Voltage [V]	Output Current (Max)[A]	Quiescent Current [μA]	Switching Frequency (Max)[MHz]	Light Load Mode	Operating Temperature [°C]	Package	Compliant Standard
BD9V100MUF-C	70	16.0 to 60.0	0.8 to 5.5	1	2500	2.3	-	-40 to +125	VQFN24FV4040	AEC-Q100 (Automotive Grade)
BD9V101MUF-LB	70	16.0 to 60.0	0.8 to 5.5	1	2500	2.3	-	-40 to +150 (Tj)	VQFN24FV4040	-
BD9P105EFV-C	42	3.5 to 40.0	0.8 to 8.5	1	10	2.2	✓	-40 to +125	HTSSOP-B20	AEC-Q100 (Automotive Grade)
BD9P105MUF-C	42	3.5 to 40.0	0.8 to 8.5	1	10	2.2	✓	-40 to +125	VQFN20FV4040	AEC-Q100 (Automotive Grade)
BD9P108MUF-C	42	3.5 to 40.0	0.8 to 8.5	1	10	2.2	✓	-40 to +125	VQFN24FV4040	AEC-Q100 (Automotive Grade)
BD9P135EFV-C	42	3.5 to 40.0	3.3	1	10	2.2	✓	-40 to +125	HTSSOP-B20	AEC-Q100 (Automotive Grade)
BD9P135MUF-C	42	3.5 to 40.0	3.3	1	10	2.2	✓	-40 to +125	VQFN20FV4040	AEC-Q100 (Automotive Grade)
BD9P155EFV-C	42	3.5 to 40.0	5.0	1	10	2.2	✓	-40 to +125	HTSSOP-B20	AEC-Q100 (Automotive Grade)
BD9P155MUF-C	42	3.5 to 40.0	5.0	1	10	2.2	✓	-40 to +125	VQFN20FV4040	AEC-Q100 (Automotive Grade)
BD8P250MUF-C	42	3.5 to 36.0	5.0	2	8	2.4	✓	-40 to +125	VQFN24FV4040	AEC-Q100 (Automotive Grade)
BD9P205EFV-C	42	3.5 to 40.0	0.8 to 8.5	2	10	2.2	✓	-40 to +125	HTSSOP-B20	AEC-Q100 (Automotive Grade)
BD9P205MUF-C	42	3.5 to 40.0	0.8 to 8.5	2	10	2.2	✓	-40 to +125	VQFN20FV4040	AEC-Q100 (Automotive Grade)
BD9P208MUF-C	42	3.5 to 40.0	0.8 to 8.5	2	10	2.2	✓	-40 to +125	VQFN24FV4040	AEC-Q100 (Automotive Grade)
BD9P233MUF-C	42	3.0 to 36.0	3.3	2	26	2.4	✓	-40 to +125	VQFN32FAV050	AEC-Q100 (Automotive Grade)
BD9P235EFV-C	42	3.5 to 40.0	3.3	2	10	2.2	✓	-40 to +125	HTSSOP-B20	AEC-Q100 (Automotive Grade)
BD9P235MUF-C	42	3.5 to 40.0	3.3	2	10	2.2	✓	-40 to +125	VQFN20FV4040	AEC-Q100 (Automotive Grade)
BD9P255EFV-C	42	3.5 to 40.0	5.0	2	10	2.2	✓	-40 to +125	HTSSOP-B20	AEC-Q100 (Automotive Grade)
BD9P255MUF-C	42	3.5 to 40.0	5.0	2	10	2.2	✓	-40 to +125	VQFN20FV4040	AEC-Q100 (Automotive Grade)
BD9P305EFV-C	42	3.5 to 40.0	0.8 to 8.5	3	10	2.2	✓	-40 to +125	HTSSOP-B20	AEC-Q100 (Automotive Grade)
BD9P308MUF-C	42	3.5 to 40.0	0.8 to 8.5	3	10	2.2	✓	-40 to +125	VQFN24FV4040	AEC-Q100 (Automotive Grade)
BD9F500QUZ	39	4.5 to 36.0	0.6 to 14.0	5	20	2.2	✓	-40 to +85	VMMMP16LZ3030	-
BD9P608MFF-C	42	3.5 to 40.0	0.8 to 8.5	6	10	2.2	✓	-40 to +125	VFN20FV4535	AEC-Q100 (Automotive Grade)

DC-DC Converter IC: Buck Type with Built-in FET (V_{IN}=7V or higher for secondary power supplies)

Part No.	Input Voltage Maximum Rating [V]	Input Voltage [V]	Output Voltage [V]	Output Current (Max)[A]	Quiescent Current [μA]	Switching Frequency (Max)[MHz]	Light Load Mode	Operating Temperature [°C]	Package	Compliant Standard
BD9S402MUF-C	7	2.7 to 5.5	0.6 to 4.125	4	1800	2.2	-	-40 to +125	VQFN16FV3030	AEC-Q100 (Automotive Grade)

DC-DC Controller IC: Buck Type with External FET (Compatible with GaN HEMT drive)

Part No.	Input Voltage Maximum Rating [V]	Input Voltage [V]	Output Voltage [V]	Output Current (Max)[A]	Quiescent Current [μA]	Switching Frequency (Max)[MHz]	Light Load Mode	Operating Temperature [°C]	Package	Compliant Standard
☆BD9JZ01MUV	102	4.0 to 100.0	0.8 to 48.0 (with FET)	-	9	3.0	✓	-40 to +125	VQFN024V4040	-

Nano Pulse Control™ Technology Related Products (EcoGaN™)



GaN HEMT

Part No.	Drain-Source Voltage V _{DS} [V]	Drain-Source Current I _{DS} [A]	Rated Gate-Source Voltage V _{GS} Maximum Rating[V]	Drain-Source ON Resistance R _{DS(on)} [mΩ]	Total Gate Charge Q _g [nC]	Package
GNP1150TCA-Z	650	11	6	150	2.7	DFN8080AK
GNP1070TC-Z	650	20	6	70	5.2	DFN8080K
GNE1040TB	150	10	8	40	2	DFN5060
☆GNE1015TB	150	15	8	15	4.9	DFN5060
☆GNE1007TB	150	20	8	7	10.2	DFN5060

Nano Energy™ Technology Product Lineup



DC-DC Converter ICs: Built-in FET

Part No.	Topology	Input Voltage Maximum Rating [V]	Input Voltage [V]	Output Voltage [V]	Output Current (Max)[A]	Quiescent Current [μA]	Switching Frequency (Max)[MHz]	Enable	Power Good	Operating Temperature [°C]	Package	Compliant Standard
BD70522GUL	Buck	6	2.5 to 5.5	1.2 to 3.3 (Selectable)	0.5	0.18	1	✓	✓	-40 to +85	VCSP50L1C	-
☆BD8B133NVX	Boost	4.5	0.9 to 3.6	1.8 / 3.0 / 3.3	1.0	0.18	4	✓	-	-40 to +85	SSON06RX2020	-

Voltage Detectors: Window-Type (Detects both sides)

Part No.	Over Voltage Detection Voltage [V]	Under Voltage Detection Voltage [V]	Detection Voltage Accuracy [%]	Reset Operating Voltage [V]	Output Type	Delay Time Setting	Circuit Current(OFF) [μA]	Operating Temperature [°C]	Package	Compliant Standard
BD48HW0G-C	1.277/Adjustable	1.277/Adjustable	±0.75	1.8 to 40.0	Open Drain	-	0.5	-40 to +125	SSOP6	AEC-Q100 (Automotive Grade)
BD52W01G-C	1.32	1.08	±5	1.6 to 6.0	Open Drain	Adjustable Delay	0.3	-40 to +125	SSOP6	AEC-Q100 (Automotive Grade)
BD52W02G-C	1.65	1.35	±5	1.6 to 6.0	Open Drain	Adjustable Delay	0.3	-40 to +125	SSOP6	AEC-Q100 (Automotive Grade)
BD52W03G-C	1.98	1.62	±5	1.6 to 6.0	Open Drain	Adjustable Delay	0.3	-40 to +125	SSOP6	AEC-Q100 (Automotive Grade)
BD52W04G-C	2.75	2.25	±5	1.6 to 6.0	Open Drain	Adjustable Delay	0.3	-40 to +125	SSOP6	AEC-Q100 (Automotive Grade)
BD52W05G-C	3.63	2.97	±5	1.6 to 6.0	Open Drain	Adjustable Delay	0.3	-40 to +125	SSOP6	AEC-Q100 (Automotive Grade)
BD52W06G-C	5.5	4.5	±5	1.6 to 6.0	Open Drain	Adjustable Delay	0.3	-40 to +125	SSOP6	AEC-Q100 (Automotive Grade)

Voltage Detectors: Over Voltage Detection Type

Part No.	Over Voltage Detection Voltage [V]	Under Voltage Detection Voltage [V]	Detection Voltage Accuracy [mV]	Reset Operating Voltage [V]	Output Type	Delay Time Setting	Circuit Current(OFF) [μA]	Operating Temperature [°C]	Package	Compliant Standard
BD70H12G-2C	1.2	-	±50	0.8 to 6	Open Drain	-	0.3	-40 to +125	SSOP5	AEC-Q100 (Automotive Grade)
BD70H35G-2C	3.46	-	±50	0.8 to 6	Open Drain	-	0.3	-40 to +125	SSOP5	AEC-Q100 (Automotive Grade)
BD70H36G-2C	3.56	-	±50	0.8 to 6	Open Drain	-	0.3	-40 to +125	SSOP5	AEC-Q100 (Automotive Grade)
BD70H37G-2C	3.66	-	±50	0.8 to 6	Open Drain	-	0.3	-40 to +125	SSOP5	AEC-Q100 (Automotive Grade)
BD70H38G-2C	3.76	-	±50	0.8 to 6	Open Drain	-	0.3	-40 to +125	SSOP5	AEC-Q100 (Automotive Grade)
BD73H35G-2C	3.46	-	±50	0.8 to 6	CMOS	-	0.3	-40 to +125	SSOP5	AEC-Q100 (Automotive Grade)
BD73H36G-2C	3.56	-	±50	0.8 to 6	CMOS	-	0.3	-40 to +125	SSOP5	AEC-Q100 (Automotive Grade)
BD73H37G-2C	3.66	-	±50	0.8 to 6	CMOS	-	0.3	-40 to +125	SSOP5	AEC-Q100 (Automotive Grade)
BD73H38G-2C	3.76	-	±50	0.8 to 6	CMOS	-	0.3	-40 to +125	SSOP5	AEC-Q100 (Automotive Grade)

Voltage Detectors: Under Voltage Detection Type

Part No.	Over Voltage Detection Voltage [V]	Under Voltage Detection Voltage [V]	Detection Voltage Accuracy [%]	Reset Operating Voltage [V]	Output Type	Delay Time Setting	Circuit Current(OFF) [μA]	Operating Temperature [°C]	Package	Compliant Standard
BD52xxG-2M series (0.1V step 42 types)	-	0.9 to 5.0	±2.5	0.8 to 6	Open Drain	Adjustable Delay	0.27	-40 to +105	SSOP5	AEC-Q100 (Automotive Grade)
BD53xxG-2M series (0.1V step 42 types)	-	0.9 to 5.0	±2.5	0.8 to 6	CMOS	Adjustable Delay	0.27	-40 to +105	SSOP5	AEC-Q100 (Automotive Grade)
BD52xxG-2C series (0.1V step 42 types)	-	0.9 to 5.0	±3	0.8 to 6	Open Drain	Adjustable Delay	0.27	-40 to +125	SSOP5	AEC-Q100 (Automotive Grade)
BD53xxG-2C series (0.1V step 42 types)	-	0.9 to 5.0	±3	0.8 to 6	CMOS	Adjustable Delay	0.27	-40 to +125	SSOP5	AEC-Q100 (Automotive Grade)
BD52xxNVX-2C series (14 types)	-	0.965 to 3.1	±2.5	0.8 to 6	Open Drain	Adjustable Delay	0.27	-40 to +125	SSON004R1010	AEC-Q100 (Automotive Grade)
BD5320NVX-2C	-	2.0	±2.5	0.8 to 6	CMOS	Adjustable Delay	0.27	-40 to +125	SSON004R1010	AEC-Q100 (Automotive Grade)

CMOS Op Amp

Part No.	Input/Output Type	No. of Channels	Supply Voltage [V]	Circuit Current [μA/ch]	Input Offset Voltage [mV]	Input Bias Current [nA]	Input Voltage [V]	Output Voltage [V]	Slew Rate [V/ms]	Input Referred Noise Voltage [nV/√Hz]	Gain Bandwidth Product [KHz]	Operating Temperature [°C]	Package	Compliant Standard
☆ LMR1901YG-M	Rail-to-Rail Input/Output	1	1.7 to 5.5	0.19	0.005	0.0005	V _{SS} to V _{DD}	V _{SS} +0.040 to V _{DD} -0.040	0.3	600	1.3	-40 to +105	SSOP5	AEC-Q100 (Automotive Grade)

Nano Cap™ Technology Product Lineup



LDO Regulators

Part No.	V _i Maximum Rating [V]	Input Voltage [V]	Output Voltage [V]	Output Voltage Accuracy [%]	Output Current (Max)[A]	Quiescent Current [μA]	Output Capacitance [μF]	Input/Output Voltage Difference [V]	Shutdown Switch	Operating Temperature T _j [°C]	Package	Compliant Standard
BD900N1G-C	45	3.0 to 42	Adjustable: 1 to 18	±2.0	0.15	28	0.05 to 470	3.3V output voltage products 0.5 (I _C : 100mA)	-	-40 to +150	SSOP5	AEC-Q100 (Automotive Grade)
BD900N1WG-C	45	3.0 to 42	Adjustable: 1 to 18	±2.0	0.15	28	0.05 to 470		✓	-40 to +150	SSOP5	AEC-Q100 (Automotive Grade)
BD933N1G-C	45	3.0 to 42	3.3	±2.0	0.15	28	0.05 to 470		-	-40 to +150	SSOP5	AEC-Q100 (Automotive Grade)
BD933N1WG-C	45	3.0 to 42	3.3	±2.0	0.15	28	0.05 to 470		✓	-40 to +150	SSOP5	AEC-Q100 (Automotive Grade)
BD950N1G-C	45	3.0 to 42	5.0	±2.0	0.15	28	0.05 to 470		-	-40 to +150	SSOP5	AEC-Q100 (Automotive Grade)
BD950N1WG-C	45	3.0 to 42	5.0	±2.0	0.15	28	0.05 to 470		✓	-40 to +150	SSOP5	AEC-Q100 (Automotive Grade)
BD900N1EFJ-C	45	3.0 to 42	Adjustable: 1 to 18	±2.0	0.15	28	0.05 to 470		-	-40 to +150	HTSOP-J8	AEC-Q100 (Automotive Grade)
BD900N1WEFJ-C	45	3.0 to 42	Adjustable: 1 to 18	±2.0	0.15	28	0.05 to 470		✓	-40 to +150	HTSOP-J8	AEC-Q100 (Automotive Grade)
BD933N1EFJ-C	45	3.0 to 42	3.3	±2.0	0.15	28	0.05 to 470		-	-40 to +150	HTSOP-J8	AEC-Q100 (Automotive Grade)
BD933N1WEFJ-C	45	3.0 to 42	3.3	±2.0	0.15	28	0.05 to 470		✓	-40 to +150	HTSOP-J8	AEC-Q100 (Automotive Grade)
BD950N1EFJ-C	45	3.0 to 42	5.0	±2.0	0.15	28	0.05 to 470		-	-40 to +150	HTSOP-J8	AEC-Q100 (Automotive Grade)
BD950N1WEFJ-C	45	3.0 to 42	5.0	±2.0	0.15	28	0.05 to 470		✓	-40 to +150	HTSOP-J8	AEC-Q100 (Automotive Grade)
☆ BD9xxN1FP3-C	45	3.0 to 42	3.3, 5.0	±2.0	0.15	28	0.05 to 470	-	-40 to +150	SOT223-4	AEC-Q100 (Automotive Grade)	
☆ BD9xxN1WFP3-C	45	3.0 to 42	3.3, 5.0	±2.0	0.15	28	0.05 to 470	✓	-40 to +150	SOT223-4	AEC-Q100 (Automotive Grade)	
☆ BD9xxN1HFV-C	45	3.0 to 42	3.3, 5.0, Adjustable: 1 to 18	±2.0	0.15	28	0.05 to 470	-	-40 to +150	HVSOF6	AEC-Q100 (Automotive Grade)	
☆ BD9xxN1WHFV-C	45	3.0 to 42	3.3, 5.0, Adjustable: 1 to 18	±2.0	0.15	28	0.05 to 470	✓	-40 to +150	HVSOF6	AEC-Q100 (Automotive Grade)	
☆ BD9xxN5EFJ-C	45	3.0 to 42	3.3, 5.0, Adjustable: 1 to 18	±2.0	0.5	25	0.23 to 470	-	-40 to +150	HTSOP-J8	AEC-Q100 (Automotive Grade)	
☆ BD9xxN5WEFJ-C	45	3.0 to 42	3.3, 5.0, Adjustable: 1 to 18	±2.0	0.5	25	0.23 to 470	✓	-40 to +150	HTSOP-J8	AEC-Q100 (Automotive Grade)	
☆ BD9xxN5FP-C	45	3.0 to 42	3.3, 5.0, Adjustable: 1 to 18	±2.0	0.5	25	0.23 to 470	-	-40 to +150	TO252-3/5	AEC-Q100 (Automotive Grade)	
☆ BD9xxN5WFP-C	45	3.0 to 42	3.3, 5.0, Adjustable: 1 to 18	±2.0	0.5	25	0.23 to 470	✓	-40 to +150	TO252-5	AEC-Q100 (Automotive Grade)	
☆ BD9xxN5HFP-C	45	3.0 to 42	3.3, 5.0, Adjustable: 1 to 18	±2.0	0.5	25	0.23 to 470	-	-40 to +150	HRP5	AEC-Q100 (Automotive Grade)	
☆ BD9xxN5WHFP-C	45	3.0 to 42	3.3, 5.0, Adjustable: 1 to 18	±2.0	0.5	25	0.23 to 470	✓	-40 to +150	HRP5	AEC-Q100 (Automotive Grade)	
☆ BD9xxN5FP2-C	45	3.0 to 42	3.3, 5.0, Adjustable: 1 to 18	±2.0	0.5	25	0.23 to 470	-	-40 to +150	TO263-3/5	AEC-Q100 (Automotive Grade)	
☆ BD9xxN5WFP2-C	45	3.0 to 42	3.3, 5.0, Adjustable: 1 to 18	±2.0	0.5	25	0.23 to 470	✓	-40 to +150	TO263-5	AEC-Q100 (Automotive Grade)	

CMOS Op Amps

Part No.	Input/Output Type	No. of Channels	Supply Voltage [V]	Circuit Current [mA/ch]	Input Offset Voltage [mV]	Input Bias Current [nA]	Input Voltage [V]	Output Voltage [V]	Slew Rate [V/μs]	Output Stability @1nF	Input Referred Noise Voltage [nV/√Hz]	Gain Bandwidth Product [MHz]	Operating Temperature [°C]	Package	Compliant Standard
BD77501G	Rail-to-Rail Output	1	7 to 15	1.3	4	0.001	V _{SS} to V _{DD} -2.0	V _{SS} +0.25 to V _{DD} -0.25	10	✓	-	8	-40 to +85	SSOP5	-
BD77502FVM	Rail-to-Rail Output	2	7 to 15	1.3	4	0.001	V _{SS} to V _{DD} -2.0	V _{SS} +0.25 to V _{DD} -0.25	10	✓	-	8	-40 to +85	MSOP8	-
BD77504FV	Rail-to-Rail Output	4	7 to 15	1.3	4	0.001	V _{SS} to V _{DD} -2.0	V _{SS} +0.07 to V _{DD} -0.06	10	✓	-	8	-40 to +85	SSOP-B14	-
BD7280YG-C	Rail-to-Rail Input/Output	1	2.5 to 5.5	1.7	0.01	0.0005	V _{SS} to V _{DD}	V _{SS} +0.010 to V _{DD} -0.010	10	✓	12	7	-40 to +125	SSOP6	AEC-Q100 (Automotive Grade)
BD7281YG-C	Rail-to-Rail Input/Output	1	2.5 to 5.5	1.7	0.01	0.0005	V _{SS} to V _{DD}	V _{SS} +0.010 to V _{DD} -0.010	10	✓	12	7	-40 to +125	SSOP5	AEC-Q100 (Automotive Grade)
☆ BD7282YFJ-C	Rail-to-Rail Input/Output	2	2.5 to 5.5	1.7	0.01	0.0005	V _{SS} to V _{DD}	V _{SS} +0.010 to V _{DD} -0.010	10	✓	12	7	-40 to +125	SOP-J8	AEC-Q100 (Automotive Grade)
☆ BD7282YFVM-C	Rail-to-Rail Input/Output	2	2.5 to 5.5	1.7	0.01	0.0005	V _{SS} to V _{DD}	V _{SS} +0.010 to V _{DD} -0.010	10	✓	12	7	-40 to +125	MSOP8	AEC-Q100 (Automotive Grade)
☆ BD7284YFV-C	Rail-to-Rail Input/Output	4	2.5 to 5.5	1.7	0.01	0.0005	V _{SS} to V _{DD}	V _{SS} +0.010 to V _{DD} -0.010	10	✓	12	7	-40 to +125	SSOP-B14	AEC-Q100 (Automotive Grade)

- 1) The information contained in this document is intended to introduce ROHM Group (hereafter referred to as ROHM) products. When using ROHM products, please verify the latest specifications or datasheets before use.
- 2) ROHM products are designed and manufactured for use in general electronic equipment and applications (such as Audio Visual equipment, Office Automation equipment, telecommunication equipment, home appliances, amusement devices, etc.) or specified in the datasheets. Therefore, please contact the ROHM sales representative before using ROHM products in equipment or devices requiring extremely high reliability and whose failure or malfunction may cause danger or injury to human life or body or other serious damage (such as medical equipment, transportation, traffic, aircraft, spacecraft, nuclear power controllers, fuel control, automotive equipment including car accessories, etc. hereafter referred to as Specific Applications). Unless otherwise agreed in writing by ROHM in advance, ROHM shall not be in any way responsible or liable for any damages, expenses, or losses incurred by you or third parties arising from the use of ROHM Products for Specific Applications.
- 3) Electronic components, including semiconductors, can fail or malfunction at a certain rate. Please be sure to implement, at your own responsibilities, adequate safety measures including but not limited to fail-safe design against physical injury, and damage to any property, which a failure or malfunction of products may cause.
- 4) The information contained in this document, including application circuit examples and their constants, is intended to explain the standard operation and usage of ROHM products, and is not intended to guarantee, either explicitly or implicitly, the operation of the product in the actual equipment it will be used. As a result, you are solely responsible for it, and you must exercise your own independent verification and judgment in the use of such information contained in this document. ROHM shall not be in any way responsible or liable for any damages, expenses, or losses incurred by you or third parties arising from the use of such information.
- 5) When exporting ROHM products or technologies described in this document to other countries, you must abide by the procedures and provisions stipulated in all applicable export laws and regulations, such as the Foreign Exchange and Foreign Trade Act and the US Export Administration Regulations, and follow the necessary procedures in accordance with these provisions.
- 6) The technical information and data described in this document, including typical application circuits, are examples only and are not intended to guarantee to be free from infringement of third parties intellectual property or other rights. ROHM does not grant any license, express or implied, to implement, use, or exploit any intellectual property or other rights owned or controlled by ROHM or any third parties with respect to the information contained herein.
- 7) No part of this document may be reprinted or reproduced in any form by any means without the prior written consent of ROHM.
- 8) All information contained in this document is current as of the date of publication and subject to change without notice. Before purchasing or using ROHM products, please confirm the latest information with the ROHM sales representative.
- 9) ROHM does not warrant that the information contained herein is error-free. ROHM shall not be in any way responsible or liable for any damages, expenses, or losses incurred by you or third parties resulting from errors contained in this document.
- 10) The information contained in this document is current as of September 1st, 2023.

R2043A

ROHM Co.,Ltd.

21 Saiin Mizosaki-cho, Ukyo-ku,
Kyoto 615-8585 Japan
TEL : +81-75-311-2121 FAX : +81-75-315-0172

www.rohm.com

