

## 2. 4GHz 通信モジュール

### 定 格

品名	2. 4GHz通信モジュール	電源電圧	2.1~3.6V
型名	RM-241S	消費電力 (電流値)	送信時: 36mA 受信時: 27mA Deepスリープ時: 0.8 $\mu$ A以下
電波仕様		重量	約2.3g
周波数帯	2. 4GHz帯	外形寸法	31.1mm(縦) × 23.2mm(横) × 6.3mm(厚み)
変調方式	DSSS/O-QPSK	動作温度	-25°C~+75°C
無線規格	IEEE802.15.4準拠	保存温度	-40°C~+85°C
最大転送速度	250kbps	環境対策	RoHS対応
チャンネル数	16ch(2405MHz~2480MHz)	セキュリティ	AES128標準装備
アンテナ	外部アンテナ	ネットワーク	マルチホップ通信標準装備
アンテナ接続口	MHF_IPEX	電波法	工事設計認証取得済
最大送信電力	+10dBm(約10mW) (ソフトにより変更可能)		
受信感度	-101dBm		
最大通信距離	約400m (見通し距離)		
制御仕様		外部I/F	GPIO(24PIN) ADC(12bit × 6ch) SPI(1ch) I2C(1ch) UART(1ch)
コアプロセッサ	STM32W (ARM Cortex-M3)		
内蔵メモリ	Flash: 128KB SRAM: 8KB		

接続コネクタ 13pin × 2列(1.27ピッチピンヘッダ)  
[GH01132V100、CviLux製]

### 外形寸法図

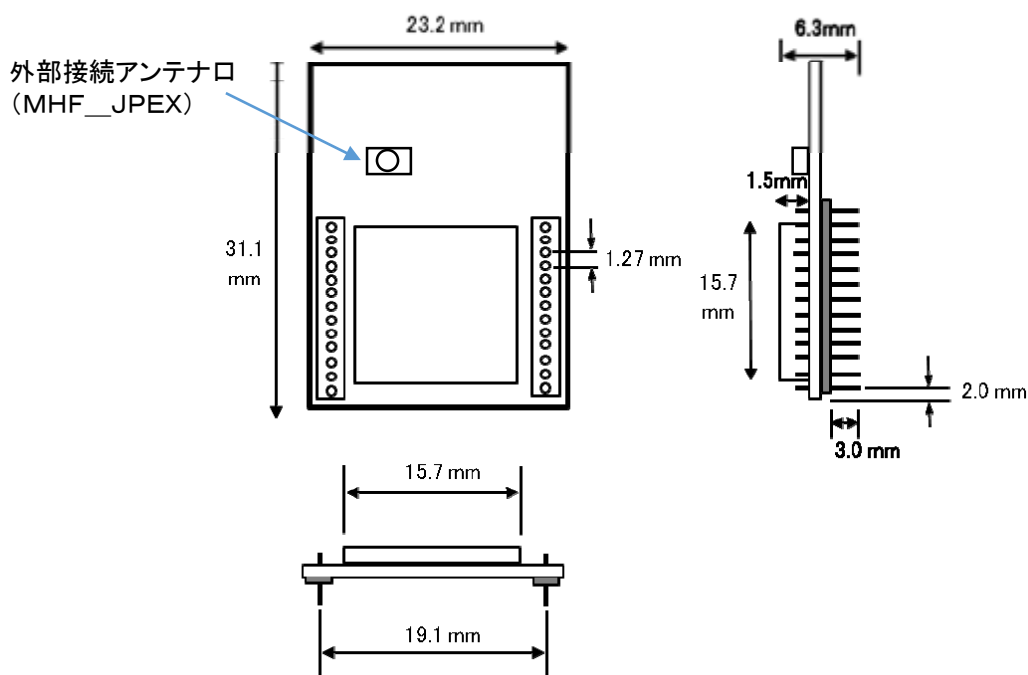

型番	GREENHOUSE	分類	発行	頁
RM-241S		RF	2016年2月 (初版)	1/2

## 2. 4GHz 通信モジュール

### ピンアサイン

Pin No	記号	I/O	内容
1	GND		GND
2	nRESET	I	Active low chip reset
3	PA1	I/O	Digital I/O
	TIM2_CH3	O	Timer 2 channel 3 output
		I	Timer 2 channel 3 input
	SC2SDA	I/O	TWI data of Serial Controller 2
	SC2MISO	O	SPI slave data out of Serial Controller 2
4	PA0	I/O	Digital I/O
	TIM2_CH1	O	Timer 2 channel 1 output
		I	Timer 2 channel 1 input
	SC2MOSI	O	SPI master data out of Serial Controller 2
		I	SPI slave data in of Serial Controller 2
5	(NC)	-	Not Connected
6	PB3	I/O	Digital I/O
	TIM2_CH3	O	Timer 2 channel 3 output
		I	Timer 2 channel 3 input
	UART_CTS	I	UART CTS Serial Controller 1
	SC1SCLK	O	SPI master clock of Serial Controller 1
7	PB4	I/O	Digital I/O
	TIM2_CH4	O	Timer 2 channel 4 output
		I	Timer 2 channel 4 input
	UART_RTS	O	UART RTS Serial Controller 1
	SC1nSSEL	I	SPI slave select of Serial Controller 1
8	PA2	I/O	Digital I/O
	TIM2_CH4	O	Timer 2 channel 4 output
		I	Timer 2 channel 4 input
	SC2SCL	I/O	TWI clock of Serial Controller 2
	SC2SCLK	O	SPI master clock of Serial Controller 2
	I	SPI slave clock of Serial Controller 2	

Pin No	記号	I/O	内容
9	PA3	I/O	Digital I/O
	SC2nSSEL	I	SPI slave select of Serial Controller 2
	TRACECLK	O	Synchronous CPU trace clock
	TIM2_CH2	O	Timer 2 channel 2 output
		I	Timer 2 channel 2 input
10	PA4	I/O	Digital I/O
	ADC4	I	ADC Input 4
	PTL_EN	O	Frame signal of Packet Trace Interface
	TRACEDATA2	O	Synchronous CPU trace data bit 2
11	PA5	I/O	Digital I/O
	ADC5	I	ADC Input 5
	PTL_DATA	O	Data signal of Packet Trace Interface
	nBOOTMODE	I	Embedded serial bootloader activation
12	PA6	I/O	Digital I/O
	TIM1_CH3	O	Timer 1 channel 3 output
		I	Timer 1 channel 3 input
	PB1	I/O	Digital I/O
	SC1MISO	O	SPI slave data out of Serial Controller 1
13	SC1MOSI	O	SPI master data out of SerialController1
	SC1SDA	I/O	TWI data of Serial Controller 1
	SC1TXD	O	UART transmit data of Serial Controller 1
	TIM2_CH1	O	Timer 2 channel 1 output
		I	Timer 2 channel 1 input
14	VCC		VCC
15	SWCLK	I/O	Serial Wire clock I/O with debugger
	JTCK	I	JTAG clock input from debugger
16	PC2	I/O	Digital I/O
	JTDO	O	JTAG data out to debugger
	SWO	O	Serial Wire Output asynchronous trace output to debugger
17	PC3	I/O	Digital I/O
	JTD1	I	JTAG data in from debugger
18	PC4	I/O	Digital I/O
	JTMS	I	JTAG mode select from debugger
	SWDIO	I/O	Serial Wire bidirectional data

Pin No	記号	I/O	内容
19	PB0	I/O	Digital I/O
	VREF	O	ADC reference output
	VREF	I	ADC reference input
	IRQA	I	External interrupt source A
	TRACECLK	O	Synchronous CPU trace clock
	TIM1CLK	I	Timer 1 external clock input
	TIM1CLK	O	Timer 2 external clock mask input
20	PC1	I/O	Digital I/O
	ADC3	I	ADC Input 3
	SWO	O	Serial Wire Output output to debugger
21	TRACEDATA0	O	Synchronous CPU trace data bit 0
	PC0	I/O	Digital I/O
	JRST	I	JTAG reset input from debugger
	IRQD	I	Default external interrupt source D
22	TRACEDATA1	O	Synchronous CPU trace data bit 1
	PB7	I/O	Digital I/O
	ADC2	I	ADC Input 2
	IRQC	I	Default external interrupt source C
	TIM1_CH2	O	Timer 1 channel 2 output
23		I	Timer 1 channel 2 input
	PB6	I/O	Digital I/O
	ADC1	I	ADC Input 1
	IRQB	I	External interrupt source B
	TIM1_CH1	O	Timer 1 channel 1 output
24		I	Timer 1 channel 1 input
	PB5	I/O	Digital I/O
	ADC0	I	ADC Input 0
	TIM2CLK	I	Timer 2 external clock input
	TIM1MSK	I	Timer 2 external clock mask input
25	PB2	I/O	Digital I/O
	SC1MISO	I	SPI slave data in of Serial Controller 1
	SC1MOSI	I	SPI master data in of SerialController1
	SC1SCL	I/O	TWI clock of Serial Controller 1
	SC1RXD	I	UART receive data of Serial Controller 1
	TIM2_CH2	O	Timer 2 channel 2 output
26		I	Timer 2 channel 2 input
	GND		GND

### オプション



2.4GHz用  
ホイップアンテナ  
ANT-241S



ホイップアンテナ用  
専用ケーブル  
ANT-CBL

型番

RM-241S

GREENHOUSE

分類

RF

発行

2016年2月  
(初版)

頁

2 / 2