

Does colour exist when no one is watching?

Quantum mechanics' entangled pairs can be compared to a machine that throws out balls of opposite colours in opposite directions. When Bob catches a ball and sees that it is black, he immediately knows that Alice has caught a white one. In a theory that uses hidden variables, the balls had always contained hidden information about what colour to show. However, quantum mechanics says that the balls were grey until someone looked at them, when one randomly turned white and the other black. Bell inequalities show that there are experiments that can differentiate between these cases. Such experiments have proven that quantum mechanics' description is correct.

HIDDEN VARIABLES

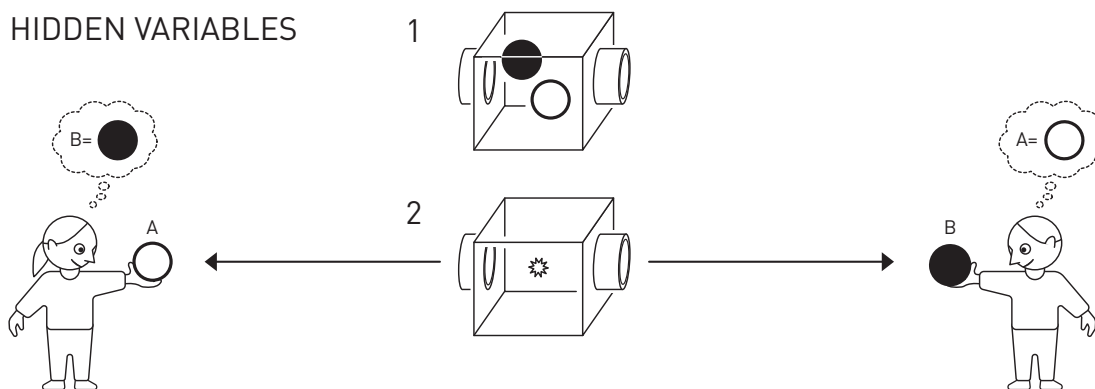

QUANTUM MECHANICS

