

\* This publication supersedes M44A2 series data published in TM 9-2320-209-20-1; TM 9-2320-209-20-2-1; TM 9-2320-209-20-2-2; TM 9-2320-209-20-3-1; TM 9-2320-209-20-3-2; TM 9-2320-209-20-3-3; TM 9-2320-209-20-3-4, 27 May 1981. Retain all TM 9-2320-209-20 publications for reference pertaining to M44 and M44A1 series trucks.

## TECHNICAL MANUAL UNIT MAINTENANCE FOR 2-1/2-TON, 6X6, M44A2 SERIES TRUCKS (MULTIFUEL)

Model		NSN Without Winch	NSN With Winch
Truck, Cargo	M 35 A 2	2320-00-077-1616	2320-00-077-1617
	M 35 A 2 C	2320-00-926-0873	2320-00-926-0875
	M 36 A 2	2320-00-077-1618	2320-00-077-1619
Truck, Tank, Fuel	M 49 A 2 C	2320-00-077-1631	2320-00-077-1632
Truck, Tank, Water	M 50 A 2	2320-00-077-1633	2320-00-077-1634
	M 50 A 3	2320-00-937-4036	2320-00-937-5264
Truck, Van, Shop	M 109 A 3	2320-00-077-1636	2320-00-077-1637
Truck, Instrument Repair Shop	M 185 A 3	4940-00-077-1638	4940-00-077-1639
Truck, Tractor	M 275 A 2	2320-00-077-1640	2320-00-077-1641
Truck, Dump	M 342 A 2	2320-00-077-1643	2320-00-077-1644
Truck, Maintenance, Pipeline Construction	M 756 A 2		2320-00-904-3277
	M 764		2320-00-937-5980
Truck, Maintenance, Earth Boring and Polesetting			

HOW TO USE THIS MANUAL	v
INTRODUCTION	1-1
SERVICE AND TROUBLESHOOTING INSTRUCTIONS	2-1
ENGINE AND CLUTCH SYSTEMS MAINTENANCE	3-1
ELECTRICAL SYSTEM MAINTENANCE	4-1
TRANSMISSION MAINTENANCE	5-1
TRANSFER CASE MAINTENANCE	6-1
PROPELLER SHAFTS, AXLES, AND SUSPENSION SYSTEM MAINTENANCE	7-1
PARKING BRAKE, COMPRESSED AIR, AND SERVICE BRAKE SYSTEM MAINTENANCE	8-1
WHEEL, HUB, DRUM, AND STEERING SYSTEM MAINTENANCE	9-1
FRAME MAINTENANCE	10-1
BODY, CAB, AND ACCESSORIES MAINTENANCE	11-1
SPECIAL PURPOSE BODIES MAINTENANCE	12-1
WINCH AND POWER TAKEOFF MAINTENANCE	13-1
SPECIAL PURPOSE KITS MAINTENANCE	14-1
SHIPMENT AND LIMITED STORAGE	15-1

DISTRIBUTION STATEMENT A. Approved for public release; distribution is unlimited.

## **WARNING**

### **EXHAUST GASES CAN KILL**

1. DO NOT operate your vehicle engine in enclosed area.
2. DO NOT idle vehicle engine with cab windows closed.
3. DO NOT drive vehicle with inspection plates or cover plates removed.
4. BE ALERT at all times for exhaust odors.
5. BE ALERT for exhaust poisoning symptoms. They are:
  - Ž Headache
  - Ž Dizziness
  - Ž Sleepiness
  - Loss of muscular control
6. If YOU SEE another person with exhaust poisoning symptoms:
  - Remove person from area
  - Expose to open air
  - Keep person warm
  - Do not permit person to move
  - Administer artificial respiration, if necessary\*

\* For artificial respiration, refer to FM 21-11.

## **WARNING SUMMARY**

- Drycleaning solvent is flammable and will not be used near open flame. Use only in well-ventilated places. Failure to do so may result in injury to personnel.
- Wear leather gloves when handling cable. Do not let cable run through hands. Broken or rusty wires can cause injury to personnel.
- Ensure new, longer front hydraulic brake lines, currently used on 5-ton trucks, are installed on all 2-1/2-ton trucks. Old, shorter front hydraulic brake lines are subject to failure during full steering travel and must be replaced with new, longer front hydraulic brake lines. Failure to do this will result in injury or death to personnel.
- Compressed air source will not exceed 30 psi (207 kPa). When cleaning with compressed air, eyeshields must be worn. Failure to wear eyeshields may result in injury to personnel.
- Do not use a dry brush or compressed air to clean brakeshoes. There may be asbestos dust on brakeshoes which can be dangerous to your health if you breathe it. (Brakeshoe must be wet, and a soft bristle brush must be used.)
- Do not perform testing near fuel tank with fill cap or sending unit removed. Fuel may ignite causing injury to personnel.
- Diesel fuel is flammable. Do not perform troubleshooting checks near open flame, sparks, or electricity. Injury to personnel may result

**WARNING SUMMARY (Contd)**

- Eye protection is required when performing fuel system troubleshooting checks. Failure to wear eye protection may result in injury to personnel.
- Ignition switch must remain OFF during fuel system troubleshooting checks. Failure to verify that ignition system is turned off may result in injury to personnel.
- Eyeshields must be worn when working with compressed air system. Failure to wear eyeshields may result in injury to personnel.
- Diesel fuel is flammable. Do not perform fuel system procedures near open flame. Injury or death to personnel may result.
- Use caution when removing radiator filler cap. Steam or hot coolant under pressure may cause injury to personnel.
- Remove all jewelry such as rings, dog tags, bracelets, etc. If jewelry or disconnected battery ground cable contacts positive battery post, a direct short can result, causing damage to equipment or severe injury to personnel.
- Completely deflate tires before removing from axles if there is obvious damage to wheel components. Injury or death to personnel may result from exploding wheel components.
- Support cab body while in raised position for mount replacement. Failure to do so may result in injury to personnel.
- Do not perform this procedure while smoking or within 50 feet of sparks or open flame. Fuel is flammable and can explode easily, causing injury or death to personnel and damage to equipment.
- Air compressor becomes hot during operation. Allow compressor to cool before handling, or injury to personnel may result.
- Before performing fuel system procedures, allow engine to cool. Failure to do so may result in injury to personnel.
- Fuel pressure is sufficient to penetrate skin. Wear hand protection at all times when removing injector tubes. Failure to do so may result in injury to personnel.
- Use caution when testing thermostat, hot water may cause injury to personnel.
- Ensure vehicle is firmly supported while spring seat is removed. Failure to do so may result in injury to personnel.
- Do not disconnect air couplings before draining air reservoirs. Small parts under pressure may shoot out with high velocity, causing injury to personnel.
- All personnel must stand clear during removal of cargo body dropside. Cargo body dropside will swing free when pins are removed and injury to personnel may result.
- Leaves and plates of assembled spring are under tension. Restrain all leaves and plates while removing center bolt. Release tension slowly. Failure to do so may result in injury to personnel.
- Alternator must be supported during installation. Failure to support alternator may cause injury to personnel or damage to equipment.
- Do not smoke, have open flame, or make sparks when performing battery maintenance. Batteries may explode causing severe injury to personnel.
- If NBC exposure is suspected, all air filter media should be handled by personnel wearing protective equipment, Consult your unit NBC officer or NBC NCO for appropriate handling or disposal instructions.

## WARNING SUMMARY (Contd)

- NBC contaminated filters must be handled using adequate precautions (FM 21-40) and must be disposed of by trained personnel.
- Do not put fingers between frame and engine supports. Jack failure may result in injury to personnel.
- Do not drain oil when engine is hot. Hot oil may cause injury to personnel.
- Battery acid (electrolyte) is extremely harmful. Always wear safety goggles and rubber gloves when performing battery maintenance. Severe injury will result if acid contacts eyes or skin.
- When removing battery cables, disconnect ground cable first. Do not allow tools to come in contact with vehicle when disconnecting cable clamps. A direct short can result, causing instant heating of tools, tool damage, battery damage, or battery explosion, and severe injury to personnel.
- Eye protection is required when using wire brush for cleaning. Failure to do so may result in injury to personnel.
- Never remove tire lockring without first deflating tire. Lockring may explode off, causing injury or death to personnel.
- When assembling plates and leaves with C-clamp, the plates and leaves will be under tension. Use care not to disturb the assembly until center bolt and nut are tightened. Failure to do so may result in injury to personnel.
- Some vehicles have two separate wires and connectors. Mark wires for installation. Connecting wires on wrong terminals may cause fuel to ignite, resulting in injury to personnel.
- Do not touch hot exhaust system components with bare hands; injury to personnel will result.
- Do not remove radiator cap if engine is hot. Steam or hot coolant under pressure may cause injury to personnel.
- Do not disconnect air lines before draining air reservoirs. Small parts under pressure may shoot out with high velocity, causing injury to personnel.
- Lockring must be properly seated around wheel when installed. If lockring is not correctly installed, it may explode off when tire is inflated, causing injury or death to personnel.
- Never attempt to correct seating of lockring by hammering, striking, or forcing while tire is inflated. Lockring may explode off causing injury or death to personnel.
- Never inflate a tire without a tire inflation cage. Injury or death to personnel may result from exploding wheel components.
- Always use tire inflation equipment specified in TM 9-2610-200-24. Warn personnel to stand 10 ft (3.1m) clear of tire inflation cage while inflating tire. Injury or death may result from exploding wheel components.
- Never rest or lean against tire inflation cage while tire is being inflated or injury or death to personnel may result.
- Keep fingers clear of hood and cowling when replacing hinge. Failure to do so may result in injury to personnel.
- All personnel must stand clear during lifting operations. A snapped chain, shifting or swinging load may result in injury to personnel.
- Tailgate is heavy. Ensure tailgate is supported prior to removing pins. Failure to do so may cause injury to personnel.

**WARNING SUMMARY (Contd)**

- Always use hand throttle to control engine speed when operating winch. Avoid sudden changes in speed. Rough, jerky operation may cause broken shearpins and snapped cables. Injury to personnel or damage to equipment may result.
- Never stand between test vehicles. Assistant must remain in secondary vehicle to engage service brake if cable snaps or automatic brake fails. Failure to do this may result in injury to personnel.
- Vehicle will become charged with electricity if A-frame contacts or breaks high voltage line. Do not attempt to leave vehicle while high voltage line is in contact with A-frame or vehicle. Leaving the vehicle may result in injury to personnel.
- Do not remove slave receptacle before disconnecting battery ground cables. If energized battery cables contact cab, a direct short will result and may cause injury to personnel.
- Short, front flexible hydraulic brake lines are subject to failure during full steering travel and must be replaced with new, longer flexible hydraulic brake lines P/N 7409330. Failure to do so may cause injury or death to personnel. Refer to para. 8-16 for replacement.
- Place support under radiator before removing support plates. Failure to do so may result in injury to personnel and damage to equipment.
- Stay clear of moving parts. Failure to do so may result in injury or death to personnel.
- Improper cleaning methods and use of unauthorized cleaning solvents may injure personnel and damage equipment. Refer to TM 9-247 for correct information.
- Do not use compressed air or a dry brush for cleaning when working in areas of vehicle where asbestos brake lining dust may accumulate. Remove asbestos dust and other residue from these areas using a soft bristle brush or cloth soaked with water. Breathing asbestos dust may cause injury to personnel.
- Ensure fuel shutoff valve is OFF and remove throttle cable before cranking engine. Failure to do so may result in injury to personnel.
- Do not place fingers between frame and crossmember while replacing mount. Doing so may result in injury to personnel.
- Bracket posts must be held in position before removing U-bolts. Failure to do so may result in injury to personnel

**TECHNICAL MANUAL**  
**NO. 9-2320-361-20**

**TECHNICAL ORDER**  
**NO. 36A12-1B-1094-2**

HEADQUARTERS  
DEPARTMENT OF THE ARMY  
Washington D. C., 25 October 1991

**TECHNICAL MANUAL**  
**FOR**  
**UNIT MAINTENANCE**  
**2-1/2-Ton, 6X6, M44A2 SERIES TRUCKS**  
**(MULTIFUEL)**

<b>Model</b>		<b>NSN Without Winch</b>	<b>NSN With Winch</b>
Truck, Cargo	M35A2	2320-00-077-1616	2320-00-077-1617
	M35A2C	2320-00-926-0873	2320-00-926-0875
	M36A2	2320-00-077-1618	2320-00-077-1619
Truck, Tank, Fuel	M49A2C	2320-00-077-1631	2320-00-077-1632
Truck, Tank, Water	M50A2	2320-00-077-1633	2320-00-077-1634
	M50A3	2320-00-937-4036	2320-00-937-5264
Truck, Van, Shop	M109A3	2320-00-077-1636	2320-00-077-1637
Truck, Instrument Repair Shop	M185A3	4940-00-077-1638	4940-00-077-1639
Truck, Tractor	M275A2	2320-00-077-1640	2320-00-077-1641
Truck, Dump	M342A2	2320-00-077-1643	2320-00-077-1644
Truck, Maintenance, Pipeline Construction	M756A2		2320-00-904-3277
Truck, Maintenance, Earth Boring and Polesetting	M764		2320-00-937-5980

\* This publication supersedes M44A2 series vehicle data published in TM 9-2320-209-20-1; TM 9-2320-209-20-2-1; TM 9-2320-209-20-2-2; TM 9-2320-209-20-3-1; TM 9-2320-209-20-3-2; TM 9-2320-209-20-3-3; TM 9-2320-209-20-3-4, 27 May 1981. Retain all TM 9-2320-209-20 publications for reference pertaining to M44 and M44A1 series trucks.

**DISTRIBUTION STATEMENT A. Approved for public release;**  
distribution is unlimited.

**REPORTING OF ERRORS**

You can help improve this manual. If you find any mistakes or if you know of a way to improve the procedures, please let us know. Mail your letter, DA Form 2028 (Recommended Changes to Publications and Blank Forms), or DA Form 2028-2 located in back of this manual direct to: Commander, U.S. Army Tank-Automotive Command, ATTN: AMSTA-MB, Warren, Michigan 48397-5000. A reply will be furnished to you.

	<b>Page</b>
<b>HOW TO USE THIS MANUAL</b> .....	<b>v</b>
<b>CHAPTER 1 INTRODUCTION</b> .....	<b>1-1</b>
Section I. General Information .....	1-1
II. Equipment Description and Data .....	1-3
III. Principles of Operation .....	1-37
<b>CHAPTER 2 SERVICE AND TROUBLESHOOTING INSTRUCTIONS</b> .....	<b>2-1</b>
Section I. Repair Parts, Special Tools, TMDE, and Support Equipment .....	2-1
II. Service Upon Receipt .....	2-1
III. Preventive Maintenance Checks and Services (PMCS) .....	2-2
IV. Mechanical Systems Troubleshooting. ....	2-24
V. Compressed Air and Brake System Troubleshooting .....	2-52
VI. Electrical Systems Troubleshooting. ....	2-74
VII. STE/ICE Troubleshooting (Simplified Test Equipment for Internal Combustion Engines) .....	2-148
<b>CHAPTER 3 ENGINE AND CLUTCH SYSTEMS MAINTENANCE</b> .....	<b>3-1</b>
Section I Engine Maintenance .....	3-1
II. Engine Lubrication System Maintenance .....	3-6
III. Clutch System Maintenance .....	3-14
IV. Air Intake System Maintenance .....	3-20
V. Turbocharger Maintenance .....	3-28
VI. Fuel System Maintenance .....	3-31
VII. Accelerator System Maintenance.. ....	3-70
VIII. Exhaust System Maintenance .....	3-82
IX. Cooling System Maintenance .....	3-92

CHAPTER 4	<b>ELECTRICAL SYSTEM MAINTENANCE</b> .....	4-1
Section I.	Charging System Maintenance .....	4-1
II.	Starting System Maintenance .....	4-10
III.	Instruments, Sending Units, Switches, and Horn Maintenance .....	4-15
IV.	Lighting System Maintenance .....	4-57
V.	Battery and Battery Box Maintenance .....	4-72
VI.	Wiring Harness Maintenance .....	4-79
CHAPTER 5	<b>TRANSMISSION MAINTENANCE</b> .....	5-1
CHAPTER 6	<b>TRANSFER CASE MAINTENANCE</b> .....	6-1
CHAPTER 7	<b>PROPELLER SHAFTS, AXLES, AND SUSPENSION SYSTEM MAINTENANCE</b> .....	7-1
Section I.	Propeller Shafts Maintenance .....	7-1
II.	Front and Rear Axle Maintenance .....	7-15
III.	Front and Rear Suspension Maintenance .....	7-28
CHAPTER 8	<b>PARKING BRAKE, COMPRESSED AIR, AND SERVICE BRAKE SYSTEM MAINTENANCE</b> .....	8-1
Section I.	Parking Brake Maintenance .....	8-1
II.	Service Brake and Hydraulic Systems Maintenance .....	8-18
III.	Compressed Air System Maintenance .....	8-45
CHAPTER 9	<b>WHEEL, HUB, DRUM, AND STEERING SYSTEM MAINTENANCE</b> .....	9-1
Section I.	Wheel, Hub, and Drum Maintenance .....	9-1
II.	Steering System Maintenance .....	9-12
CHAPTER 10	<b>FRAME MAINTENANCE</b> .....	10-1
CHAPTER 11	<b>BODY, CAB AND ACCESSORIES MAINTENANCE</b> .....	11-1
Section I.	Body and Cab Maintenance .....	11-1
II.	Accessories Maintenance .....	11-56
CHAPTER 12	<b>SPECIAL PURPOSE BODIES MAINTENANCE</b> .....	12-1
Section I.	Cargo Body Maintenance .....	12-1
II.	Dump Body Maintenance .....	12-16
III.	Tank Body Maintenance .....	12-29
IV.	Van Body Maintenance .....	12-94
V.	Earth Boring and Polesetting Truck Body Maintenance .....	12-132
VI.	Pipeline Construction Body Maintenance .....	12-165
VII.	Tractor Maintenance .....	12-177



CHAPTER 13	<b>WINCH AND POWER TAKEOFF MAINTENANCE</b>	13-1
Section I.	Winch Maintenance	13-1
Section II.	Power Takeoff Controls and Linkage Maintenance	13-34
CHAPTER 14	<b>SPECIAL PURPOSE KITS MAINTENANCE</b>	14-1
Section I.	Winterization Kits Maintenance	14-1
Section II.	Van Body Primary and Secondary Heater Kit Maintenance	14-36
Section III.	Deepwater Forging Kit Maintenance	14-60
Section IV.	A-Frame Kit Maintenance	14-66
Section V.	Mounting Kit Maintenance	14-70
Section VI.	100-Amp Alternator Kit Maintenance	14-85
Section VII.	Troop Seat Mounting Kit and Seatbelt Kits Maintenance	14-92
CHAPTER 15	<b>SHIPMENT AND LIMITED STORAGE</b>	15-1
Section I.	General Preparation of Truck for Shipment	15-1
Section II.	Loading and Movement	15-2
Section III.	Limited Storage	15-2
APPENDIX A	REFERENCES	A-1
APPENDIX B	MAINTENANCE ALLOCATION CHART	B-1
APPENDIX C	EXPENDABLE/DURABLE SUPPLIES AND MATERIALS LIST	C-1
APPENDIX D	TORQUE LIMITS	D-1
APPENDIX E	SCHEMATIC AND WIRING DIAGRAMS	E-1
INDEX		Index 1

## HOW TO USE THIS MANUAL

### ABOUT YOUR MANUAL

Spend some time looking through this manual. You'll find that it has a new look, different than most of the TM's you've been using.

New features added to improve the convenience of this manual and increase your efficiency are:

- a. **Accessing Information** – These include features such as the bleed-to-edge locators on the cover and edge of the manual. Extensive troubleshooting guides for specific systems lead directly to step-by-step directions for problem solving and maintenance tasks.
- b. **Illustrations** – A variety of methods are used to make locating and fixing components much easier. Locator illustrations with keyed text, exploded views, and cut-away diagrams make the information in this manual easier to understand and follow.
- c. **Modification or Special Purpose Kits** – M44A2 series vehicles can be updated with modification kits or equipped with special purpose kits. They allow the vehicle to operate more efficiently or perform a special function. Sometimes the vehicle being worked on doesn't exactly match the maintenance procedure in this manual because the proper kit has not been installed. Refer to troubleshooting sections in chapter 2 to find troubleshooting instructions or a reference to kit installation instructions.
- d. **Keying Text With Illustrations** - Illustration and text are located on facing pages that show the specific task you are working on. In some cases, the task steps and illustrations are located side by side. Continue reading for an example of modular text and illustrations.
- e. **General Features** - Your TM is the best source available for providing information and data critical to vehicle operation and maintenance:
  - Safety summary (warning pages a, b, c, and d)
  - General information, equipment description, and data (chapter 1, sections I and II)
  - Principles of operation (chapter 1, section III)
  - Preventive Maintenance Checks and Services - PMCS (chapter 2, section III)
  - Systems Troubleshooting (chapter 2, sections IV, V, VI, and VII)
  - Detailed maintenance procedures (chapters 3 through 14)
  - Shipment and limited storage (chapter 15, sections I, II, and III)
  - References (appendix A)
  - Maintenance Allocation Chart – MAC (appendix B)
  - Expendable/durable supplies and materials list (appendix C)
  - Torque limits (appendix D)
  - Schematic and Wiring Diagrams (appendix E)

A typical example of how to use this manual is provided on the following pages.

## USING YOUR MANUAL: AN EXAMPLE

**TASK:** The operator of an M44A2 series vehicle, model number M35A2C, has complained of excessive exhaust noise and exhaust fumes entering the cab of his vehicle. The vehicle has been assigned to you for repair.

### TROUBLESHOOTING STEPS:

1. Look at the cover of this manual. You'll see chapter/section titles listed from top to bottom on the right-hand side.
2. Look at the right-edge of the manual. On some of the pages you'll see edge indicators (black bars) that are aligned with the chapter/section bars on the cover. These are the locations of the chapters/sections in the text.
3. Look for "SERVICE AND TROUBLESHOOTING INSTRUCTIONS" in the chapter list on the cover. This is where the troubleshooting information is located.
4. Turn to those pages with the edge indicator matching the black bar for service and troubleshooting instructions. Page numbers are also listed next to chapter/section titles.
5. Chapter 2 is divided into seven sections:
  - Section I - Repair Parts, Special Tools, TMDE, and Support Equipment
  - Section II - Service Upon Receipt
  - Section III - Preventive Maintenance Checks and Services (PMCS)
  - Section IV - Mechanical Systems Troubleshooting
  - Section V - Compressed Air and Brake System Troubleshooting
  - Section VI - Electrical Systems Troubleshooting
  - Section VII - STE/ICE Troubleshooting
6. Turn to section IV, "MECHANICAL SYSTEMS TROUBLESHOOTING" (page 2-24). This troubleshooting section is system-oriented and is broken down into 25 major vehicle systems.
7. One of the first pages of this section is the "MECHANICAL TROUBLESHOOTING SYMPTOM INDEX" (turn to page 2-25).
8. Look down the list until you find "EXHAUST SYSTEM." Beneath that heading you will find the symptoms noted by the vehicle operator: "Excessive exhaust noise" and "Exhaust fumes in cab."
9. Turn to the page indicated: 2-33.

**\* ARMY TM 9-2320-361-20  
AIR FORCE TO 36A12-1B-1094-2**

\* This publication supersedes M44A2 series data published in TM 9-2320-209-20-1; TM 9-2320-209-20-1; TM 9-2320-209-20-2; TM 9-2320-209-20-3; TM 9-2320-209-20-4; TM 9-2320-209-20-5; TM 9-2320-209-20-6; 21 May 1981. Retain all TM 9-2320-209-20 publications for reference pertaining to M44 and M44A1 series trucks.

HOW TO USE THIS MANUAL	v
INTRODUCTION	1-1
SERVICE AND TROUBLESHOOTING INSTRUCTIONS	2-1
ENGINE AND CLUTCH SYSTEMS MAINTENANCE	3-1
ELECTRICAL SYSTEM MAINTENANCE	4-1
TRANSMISSION MAINTENANCE	5-1
TRANSFER CASE MAINTENANCE	6-1
PROPELLER SHAFTS, AXLES, AND SUSPENSION SYSTEM MAINTENANCE	7-1
PARKING BRAKE, COMPRESSED AIR, AND SERVICE BRAKE SYSTEM MAINTENANCE	8-1
WHEEL, HUB, DRUM, AND STEERING SYSTEM MAINTENANCE	9-1
FRAME MAINTENANCE	10-1
BODY, CAB, AND ACCESSORIES MAINTENANCE	11-1
SPECIAL PURPOSE BODIES MAINTENANCE	12-1
WINCH AND POWER TAKEOFF MAINTENANCE	13-1
SPECIAL PURPOSE KITS MAINTENANCE	14-1
SHIPMENT AND LIMITED STORAGE	15-1

**TECHNICAL MANUAL  
UNIT MAINTENANCE  
FOR  
2-1/2-TON, 6X6,  
M44A2 SERIES TRUCKS  
(MULTIFUEL)**

**TRUCK, CARGO: 2-1/2-TON, 6X6,  
M35A2, M35A2C, M36A2;  
TRUCK, TANK, FUEL: 2-1/2-TON, 6X6, M49A2C;  
TRUCK, TANK, WATER: 2-1/2-TON, 6X6,  
M50A2, M50A3;  
TRUCK, VAN, SHOP: 2-1/2-TON, 6X6, M109A3;  
TRUCK, INSTRUMENT REPAIR SHOP:  
2-1/2-TON, 6X6, M185A3;  
TRUCK, TRACTOR: 2-1/2-TON, 6X6, M275A2;  
TRUCK, DUMP: 2-1/2-TON, 6X6, M342A2;  
TRUCK, MAINTENANCE, PIPELINE  
CONSTRUCTION: 2-1/2-TON, 6X6, M756A2;  
TRUCK, MAINTENANCE;  
EARTH BORING AND POLESETTING:  
2-1/2-TON, 6X6, M764**

DISTRIBUTION STATEMENT A. Approved for public release; distribution is unlimited.

**DEPARTMENTS OF THE ARMY AND THE AIR FORCE**

TM 9-2320-361-20

**MECHANICAL SYSTEMS TROUBLESHOOTING  
SYMPTOM INDEX**

MALFUNCTION NO.	MALFUNCTION	TROUBLESHOOTING PROCEDURE PAGE
<b>ENGINE</b>		
1.	Engine will not crank	2-28
2.	Engine cranks but will not start	2-28
3.	Starter cranks engine slowly	2-29
4.	Engine stops during normal operation	2-29
5.	Engine stops when accelerator is returned to idle position	2-30
6.	Engine misfires during operation	2-30
7.	Poor acceleration and/or lack of power	2-30
8.	Engine surges	2-31
9.	Excessive engine oil loss or consumption during normal operation	2-31
10.	Engine oil pressure too low or too high at normal operation temperature	2-31
11.	Excessive vibration or clunking	2-32
12.	Excessive fuel consumption	2-32
<b>EXHAUST SYSTEM</b>		
13.	Exhaust color blue during normal operation	2-32
14.	Exhaust color white during normal operation and idle	2-32
15.	Excessive exhaust noise	2-33
16.	Exhaust fumes in cab	2-33
<b>MANIFOLD HEATER SYSTEM</b>		
17.	Engine cranks but will not start in cold weather (fuel system operating properly)	2-33
<b>COOLING SYSTEM</b>		
18.	Engine temperature gage above 230°F (110°C)	2-34
19.	Engine does not reach normal operating temperature	2-34
20.	Coolant loss during normal operation	2-34
<b>FUEL SYSTEM</b>		
21.	No fuel at fuel injectors	2-35
<b>PERSONNEL HOT WATER HEATER</b>		
22.	Personnel hot water heater does not heat cab	2-35
<b>TRANSMISSION</b>		
23.	Transmission noisy	2-35
24.	Transmission leaks oil	2-36
<b>CLUTCH</b>		
25.	Clutch pedal will not travel or depress	2-36
26.	Vehicle creeps with clutch depressed	2-36
27.	Clutch drags, slips, or does not engage	2-36

2-25

- On page 2-33, step/test relating to resolving the problem of "Excessive exhaust noise" is listed:

Step 1. During your inspection, you discover that an exhaust pipe is cracked and rusted. The part must be replaced. Chapter 3, section VIII is referenced.

- Turn to the "TABLE OF CONTENTS" and find the chapter dealing with the engine. You find it as "CHAPTER 3, ENGINE AND CLUTCH SYSTEMS MAINTENANCE." Furthermore, you note that the chapter is divided into nine sections; you are interested in "Section VIII. Exhaust System Maintenance."

**NOTE:** Before attempting to repair or replace the exhaust system, as a Unit mechanic, you must:

- Determine the maintenance responsibility of repair or replacement of the component.
- If the task is at your echelon of maintenance responsibility, you must identify the tools needed and the replacement parts required.

Refer to the Maintenance Allocation Chart - MAC (appendix B) to determine not only the maintenance responsibility of the item, but also to obtain an estimate of the time required to perform the task, tools needed, and any special notes/requirements necessary.

Refer to TM 9-2320-361-20P, Unit Maintenance Repair Parts and Special Tools List for M44A2 Series Vehicles, for requisition data concerning replacement parts for this task.

- Turn to chapter 3, section VIII, which covers "EXHAUST SYSTEM MAINTENANCE." In the maintenance index we find that there are two paragraphs listed, para. 3-37 and 3-38.
- Paragraph 3-38 is a task for replacing the exhaust system used only on model M50A2 and M50A3 vehicles. All other M44A2 series vehicles will follow para. 3-37 for replacement of the exhaust system. Notice that, in this case, it starts on the same page, 3-82.
- The first two pages shown have procedures and illustrations for performing the removal steps for components of the exhaust system.

TM 9-2320-361-20

Table 2-2. Mechanical Troubleshooting (Contd.)

MAIFUNCTION TEST OR INSPECTION CORRECTIVE ACTION
<p><b>15. EXCESSIVE EXHAUST NOISE</b></p> <p>Step 1. Inspect turbocharger for secure mounting and exhaust leaks. If turbocharger mountings are loose, tighten 23-27 lb-ft (31-37 N-m).</p> <p>Step 2. Inspect exhaust pipes for secure connections, cracks, breaks, and excessive rust. Replace damaged parts (chapter 3, section VIII).</p> <p>Step 3. Inspect exhaust stack for secure connections, cracks, and breaks. Replace damaged parts (chapter 3, section VIII).</p> <p>Step 4. If excessive exhaust noise still exists, it may be necessary to install exhaust insulator kit 12300664.</p> <p style="text-align: center;">END OF TESTING!</p>
<p><b>16. EXHAUST FUMES IN CAB</b></p> <p>Step 1. Inspect exhaust manifold, turbocharger, exhaust pipes, and connections for leaks. Replace damaged parts (chapter 3, section VIII).</p> <p>Step 2. Inspect exhaust manifold and turbocharger for leaks. If leaking, notify supervisor.</p> <p style="text-align: center;">END OF TESTING!</p> <p style="text-align: center;"><b>MANIFOLD HEATER SYSTEM</b></p>
<p><b>17. ENGINE CRANKS BUT WILL NOT START IN COLD WEATHER (FUEL SYSTEM OPERATING PROPERLY)</b></p> <p>Step 1. Check manifold heater system electrical circuit (table 2.4, malfunction 39).</p> <p>Step 2. Check fuel pump supply lines and filter for leaks, bends, kinks, and restrictions. If vehicle is equipped with alcohol evaporator, check for proper operation as required (TM 9-2320-361-10).</p> <p style="text-align: center;"><b>WARNING</b></p> <p>Diesel fuel is flammable. Do not perform fuel system procedures near open flame. Injury to personnel may result.</p> <p style="text-align: center;"><b>NOTE</b></p> <ul style="list-style-type: none"> <li>Have drainage container ready to catch fuel.</li> <li>During steps 3 and 4, do not confuse in-tank fuel pump pressure with manifold heater pump pressure.</li> </ul> <p>Step 3. Disconnect fuel line at fuel nozzle, energize manifold heater circuit and check to see if fuel is discharged. If fuel is not discharged, replace manifold heater fuel pump (para. 3-30 or 3-31).</p> <p>Step 4. Check fuel nozzle for proper operation. Remove fuel return lines (para. 3-27). Energize circuit and check to see if fuel is discharged. If fuel is not discharged, notify supervisor.</p> <p style="text-align: center;">END OF TESTING!</p>

2-33

TM 9-2320-361-20

Section VIII. EXHAUST SYSTEM MAINTENANCE

3-36. EXHAUST SYSTEM MAINTENANCE INDEX		
PARA. NO.	TITLE	PAGE NO.
3-37.	Exhaust System Replacement	3-82
3-38.	Exhaust System (M50A2 and M50A3) Replacement	3-86

3-37. EXHAUST SYSTEM REPLACEMENT	
This task covers:	
a. Removal	b. Installation
<p><b>INITIAL SETUP:</b></p> <p><b>APPLICABLE MODELS</b> All except M50A2, M50A3</p> <p><b>MATERIALS/PARTS</b> Four gaskets Ten locknuts Two lockwashers</p> <p><b>REFERENCES (TM)</b> TM 9-2320-361-10 TM 9-2320-361-20P</p>	<p><b>EQUIPMENT CONDITION</b> Air cleaner element removed (para. 3-14).</p> <p><b>GENERAL SAFETY INSTRUCTIONS</b> Do not touch hot exhaust system components with bare hands.</p>
<b>WARNING</b>	
Do not touch hot exhaust system components with bare hands. Severe injury to personnel will result.	
<p>a. Removal</p> <ol style="list-style-type: none"> <li>Remove locknut (13) and screw (7) from coupling (14). Discard locknut (13).</li> <li>Disconnect elbow (9) from flex tube (15), and remove coupling (14) and gasket (8) from elbow (9). Discard gasket (8).</li> <li>Loosen clamp (11) and remove elbow (9), clamp (11), and gasket (10) from turbocharger (12). Discard gasket (10).</li> <li>Remove locknut (22) and screw (21) from coupling (23), and remove flex tube (15), coupling (23), and gasket (24) from exhaust pipe (29). Discard gasket (24) and locknut (22).</li> <li>Remove locknut (2) and screw (38) from coupling (39). Discard locknut (2).</li> <li>Remove stack pipe (1), coupling (39), and gasket (40) from exhaust pipe (29). Discard gasket (40).</li> <li>Remove four locknuts (4), screws (36), two clamps (3), and exhaust shield (35) from exhaust pipe (29). Discard locknuts (4).</li> <li>Remove two locknuts (30), washers (31), screws (34), washers (33), and cover plates (18) from fender (32). Discard locknuts (30).</li> </ol>	

3-82

**DETAILED MAINTENANCE PROCEDURES:**

15. Detailed procedures: Include everything you must do to accomplish a basic maintenance task.
  - a. Before beginning the maintenance task, look through the procedure. You must familiarize yourself with the entire maintenance procedure before beginning the maintenance task. The entire procedure of paragraph 3-37: "EXHAUST SYSTEM REPLACEMENT" includes: a. Removal and b. Installation.
  - b. The eight basic headings listed under "INITIAL SETUP" outline special tools, materials, personnel requirements, and special conditions. Headings will not be listed if there are no entries. The headings are:
    - **APPLICABLE MODELS** Any models that require that particular maintenance task.
    - **TEST EQUIPMENT** Test equipment needed to complete a task.
    - **SPECIAL TOOLS** Those special tools needed to complete a task. Common tools are not listed.
    - **MATERIALS/PARTS** All parts or materials needed to complete a task.
    - **PERSONNEL REQUIRED** The number of personnel needed to perform a task. If only one mechanic is needed, this heading will not be used. If you think that you need more help to correctly or safely complete a task (perhaps as the result of unusual conditions, etc.), alert your supervisor and ask for help.
    - **REFERENCES (TM)** Those additional manuals needed to complete a task.
    - **EQUIPMENT CONDITION** Notes the conditions that must exist before starting the task. For exhaust system replacement, the vehicle must have the parking brake set and the air cleaner element removed.
    - **GENERAL SAFETY INSTRUCTIONS** Summarizes all safety warnings for the maintenance task.
  - c. A step-by-step maintenance procedure follows the "INITIAL SETUP" and gives detailed instructions for the procedure. These instructions give part name and action performed. The numbers in parentheses correspond to the part's callout number in the accompanying illustration. Warnings, cautions, and notes give additional information.
    - **WARNINGS** - Indicate conditions, practices, or procedures which must be observed to avoid personnel injury, loss of life, or long-term health hazard.
    - **CAUTIONS** - Indicate conditions, practices, or procedures which must be observed to avoid damage to equipment or destruction of equipment.
    - **NOTES** - Include essential information of special importance, interest, or aid in job performance.
  - d. At the end of a procedure, "FOLLOW-ON TASKS" will list those additional tasks that must be performed to complete the procedure.
16. You can also use the Table of Contents (page ii) to find more information about the vehicle. For example: Principles of Operation in chapter 1.
17. Unit PMCS are presented in table 2-1 starting on page 2-4.
18. Chapter 2, section VII, STE/ICE Troubleshooting, can be used if STE/ICE is available for troubleshooting or PMCS.
19. Refer to TM 9-2320-361-20P, Unit Maintenance Repair Parts and Special Tools List for Truck, 2-1/2-Ton, 6x6, M44A2 Series, when requisitioning parts, special tools, and equipment for unit maintenance.
20. Your manual is easier to use once you understand its design. We hope it will encourage you to use it more often as an aid to maintenance support for M44A2 series vehicles.

## CHAPTER 1 INTRODUCTION

- Section I. General Information (page 1-1)  
Section II. Equipment Description and Data (page 1-3)  
Section III. Principles of Operation (page 1-37)

### Section I. GENERAL INFORMATION

#### 1-1. SCOPE

a. This technical manual contains instructions for unit maintenance of 2-1/2-ton, 6x6, multifuel, M44A2 series vehicles.

b. The vehicle model numbers and equipment names are:

- (1) M35A2 Cargo Truck, WO/W and W/W
- (2) M35A2C Cargo Truck With Dropsides, WO/W and W/W
- (3) M36A2 Cargo Truck With Extra Long Wheelbase, WO/W and W/W
- (4) M49A2C Fuel Tank Truck, WO/W and W/W
- (5) M50A2 Water Tank Truck (400- and 600-Gallon Tanks), WO/W and W/W
- (6) M50A3 Water Tank Truck (Two 500-Gallon Tanks), WO/W and W/W
- (7) M109A3 Shop Van Truck, WO/W and W/W
- (8) M185A3 Instrument Repair Shop Truck, WO/W and W/W
- (9) M275A2 Tractor Truck, WO/W and W/W
- (10) M342A2 Dump Truck, WO/W and W/W
- (11) M756A2 Pipeline Construction Maintenance Truck, W/W
- (12) M764 Earth Boring and Polesetting Maintenance Truck, W/W

#### 1-2. MAINTENANCE FORMS, RECORDS, AND REPORTS

Department of the Army forms and procedures used for equipment maintenance will be those prescribed by DA Pam 738-750, The Army Maintenance Management System (TAMMS).

#### 1-3. DESTRUCTION OF ARMY MATERIEL TO PREVENT ENEMY USE

Procedures for destruction of Army materiel to prevent enemy use can be found in TM 750-244-6.

#### 1-4. PREPARATION FOR STORAGE OR SHIPMENT

Storage and shipment instructions are in Chapter 15, Shipment and Limited Storage, of this manual and TM 746-10, Marking, Packaging and Shipment of Supplies and Equipment: General Packaging Instructions for Field Use.

#### 1-5. REPORTING QUALITY DEFICIENCIES, IDEAS, AND EQUIPMENT IMPROVEMENT RECOMMENDATIONS

If your 2-1/2-ton, M44A2 series vehicle needs improvement, let us know. Send us an EIR. You, the user, are the only one who can tell us what you don't like about your equipment. Let us know why you don't like the design. Put it on an SF 368 (Quality Deficiency Report). Mail in accordance with DA PAM 738-750.

## **1-6. EQUIPMENT IMPROVEMENT REPORT AND MAINTENANCE DIGEST (EIR MD)**

The quarterly Equipment Improvement Report and Maintenance Digest, TB 43-0001-39 series, contains valuable field information on the equipment covered in this manual. The information in the TB 43-0001-39 series is compiled from some of the Equipment Improvement Reports that you prepared on the vehicles covered in this manual. Many of these articles resulted from comments, suggestions, and improvement recommendations that you submitted to the EIR program. The TB 43-0001-39 series contains information on equipment improvements minor alterations, proposed Modification Work Orders (MWO's), warranties (if applicable), actions taken on some of your DA Form 2028's (Recommended Changes to Publications), and advance information on proposed changes that may affect this manual. The information will help you in doing your job better and will help in keeping you advised of the latest changes to this manual. Also refer to DA Pam 25-30, Consolidated Index of Army Publications and Blank Forms, and Appendix A of this manual.

## **1-7. WARRANTY INFORMATION**

The transfer, transmission, transmission shaft, front axle assembly, rear axle assembly, differential carrier, air hydraulic cylinder, steering gear, cargo body, winch, power takeoff assembly, and delivery pump are warranted in accordance with TB 9-2320-209-14 for the M35A2 and M35A2C cargo trucks, M49A2C fuel tank truck, M50A3 water tank truck, and M275A2 tractor truck. The warranty starts on the date found in block 23, DA Form 2408-9, in the logbook. Report all defects in material or workmanship to your supervisor, who will take appropriate action.

## Section II. EQUIPMENT DESCRIPTION AND DATA

### 1-8. GENERAL

M44A2 series, 6x6, 2-1/2-ton vehicles are highly mobile tactical vehicles capable of traveling over most terrain types under severe weather conditions. The vehicles of this series utilize common cab, body, engine, drivetrain, electrical, brake, and chassis components that accommodate a variety of configurations to accomplish multiple combat support and service roles. All M44A2 series vehicles have a pintle hook for towing. Tiedowns and lifting shackles are used for air, rail, or sea shipment. All vehicles described in this section may be equipped with a front winch for recovery operations.

### 1-9. EQUIPMENT DESCRIPTION AND DATA INDEX

PARA. NO.	TITLE	PAGE NO.
1-10.	Equipment Characteristics, Capabilities, and Features	1-4
1-11.	Location and Description of Major External Components	1-10
1-12.	Location and Description of Major Internal Components	1-12
1-13.	Location and Contents of Warning, Caution, and Data Plates	1-14
1-14.	Differences Between Models	1-30
1-15.	Equipment Data	1-31



**1-10. EQUIPMENT CHARACTERISTICS, CAPABILITIES, AND FEATURES**

**a. M35A2 Cargo Truck, WO/W and W/W.**

**PURPOSE:** This model is used to transport cargo and troops. The M35A2 has permanent steel-welded sides, making it a preferred vehicle when transporting bulky or shifting loads. Side racks have built-in troop seats which may be positioned for troop transport operations. A bow and tarpaulin kit is available.

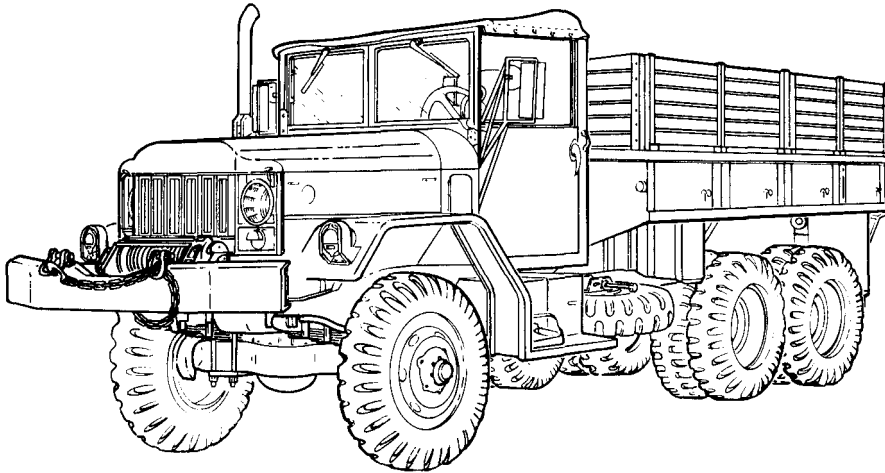

**M35A2 CARGO TRUCK W/W**

**b. M35A2C Cargo Truck With Dropsides, WO/W and W/W.**

**PURPOSE:** M35A2C cargo trucks are used to transport cargo and troops. The hinged steel sides can be folded down or removed for easy side loading and unloading operations. Side racks have built-in troop seats which may be positioned for troop transport operations. A bow and tarpaulin kit is available.

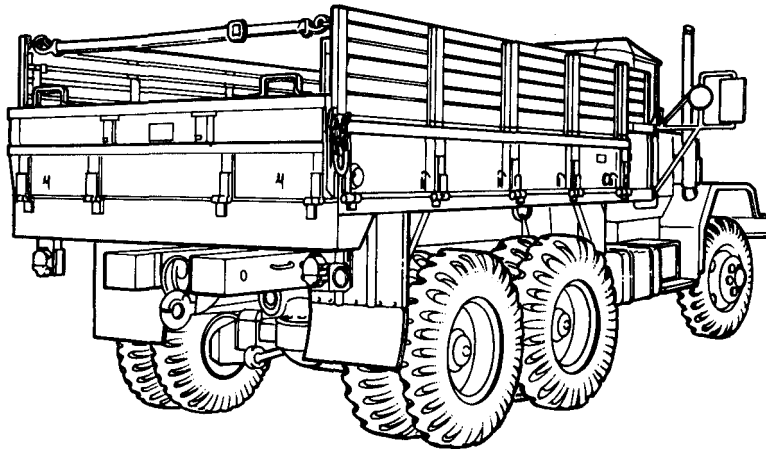

**M35A2C CARGO TRUCK WITH DROPSIDES**

**1-10. EQUIPMENT CHARACTERISTICS, CAPABILITIES, AND FEATURES (Contd)****c. M36A2 Cargo Truck With Extra Long Wheelbase (XLWB), WO/W and W/W.**

PURPOSE: M36A2 cargo trucks have the same load capacities as M35A2 and M35A2C. However, the M36A2 truck bed is 63 inches (160 centimeters) longer. This provides each vehicle with an additional 140 cubic feet (3.9 cubic meters) of cargo space. Only the hinged right side can be folded down or removed for easy side loading and unloading operations. No troop seats are available for this model. A bow and tarpaulin kit with end flaps is available.

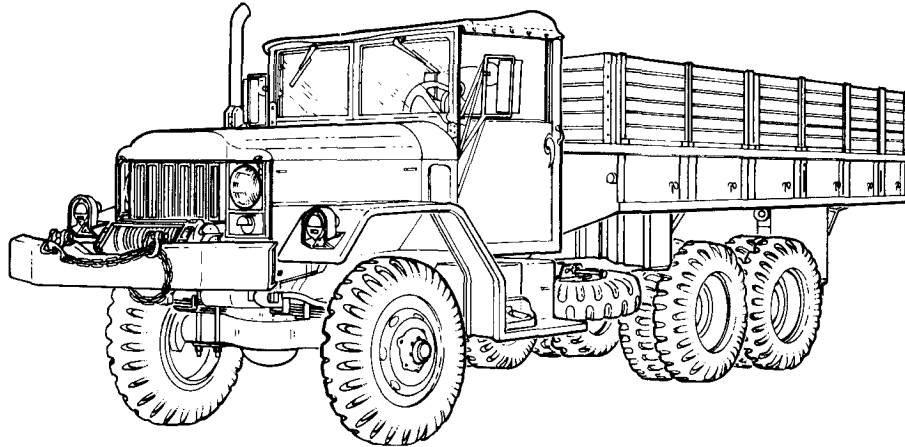
**M36A2 CARGO TRUCK WITH EXTRA LONG WHEELBASE W/W****d. M49A2C Fuel Tank Truck, WO/W and W/W.**

PURPOSE: M49A2C fuel tank trucks are used to transport and discharge fuel. The two 600-gallon (2271 L) tanks can be filled or emptied with or without the use of a delivery pump located in the rear body compartment. The pump can also be used to transfer fuel from one container to another. Only the 600-gallon (2271 L) tank located over the rear axle may be filled for cross-country operations.

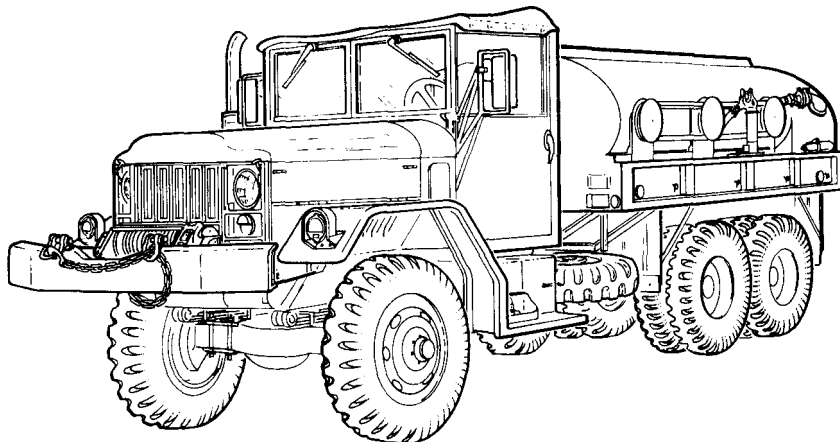
**M49A2C FUEL TANK TRUCK W/W**

**1-10. EQUIPMENT CHARACTERISTICS, CAPABILITIES, AND FEATURES (Contd)**

**e. M50A2, M50A3 Water Tank Truck, WO/W and W/W.**

PURPOSE: M50A2 and M50A3 water tank trucks are used to transport and discharge water. Filling, emptying, and transferring water is done the same way fuel is filled, emptied, and transferred on the M49A2C fuel tank truck. The M50A2 has a 400-gallon (1514 L) tank in front and a 600-gallon (2271 L) tank located over the rear axles. The M50A3 has two 500-gallon (1893 L) tanks. Only the tank located over the rear axle may be filled for cross-country operations.

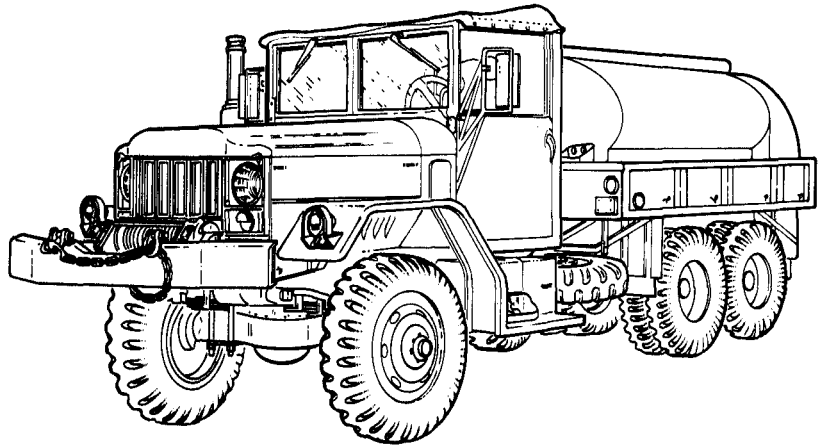

**M50A2, M50A3 WATER TANK TRUCK W/W**

**f. M109A3 Shop Van Truck, WO/W and W/W.**

PURPOSE: M109A3 shop van truck is used as a mobile repair shop. It may be used to transport special equipment that must be kept free of dirt, dust, and moisture. This vehicle is not reducible in height.

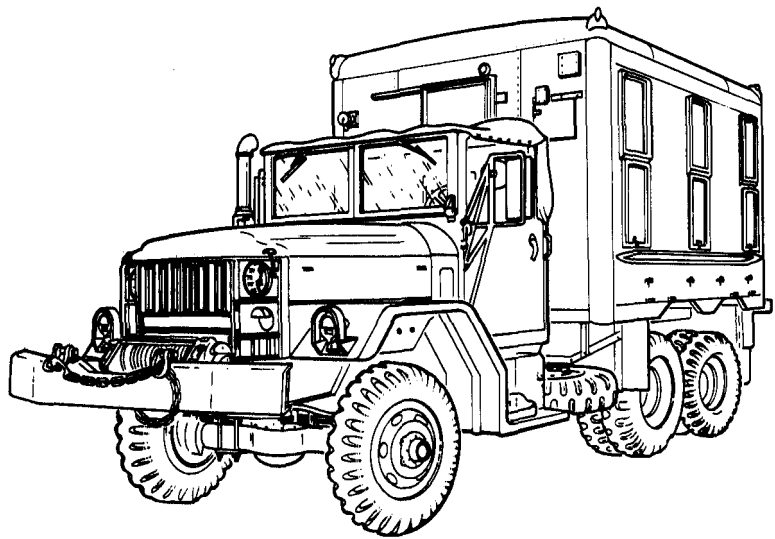

**M109A3 SHOP VAN TRUCK W/W**

**1-10. EQUIPMENT CHARACTERISTICS, CAPABILITIES, AND FEATURES (Contd)****g. M185A3 Instrument Repair Shop Truck, WO/W and W/W.**

PURPOSE: M185A3 has special equipment (grinder with wire wheel, vise, drill sets, etc.) included with the vehicle to allow for more extensive field repairs. This vehicle is not reducible in height.

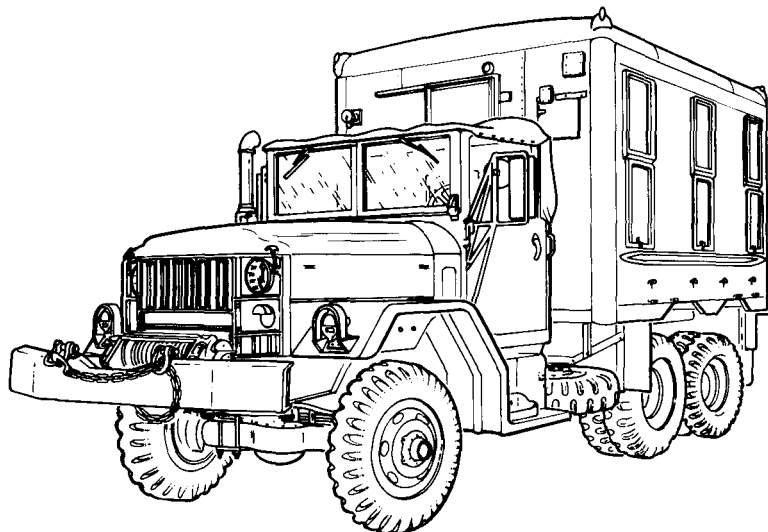

**M185A3 INSTRUMENT REPAIR SHOP TRUCK W/W**

**h. M275A2 Tractor Truck, WO/W and W/W.**

PURPOSE: M275A2 tractor truck is equipped with a fifth wheel used to transport a semitrailer. The M275A2, when attached to a semitrailer, has limited cross-country applications.

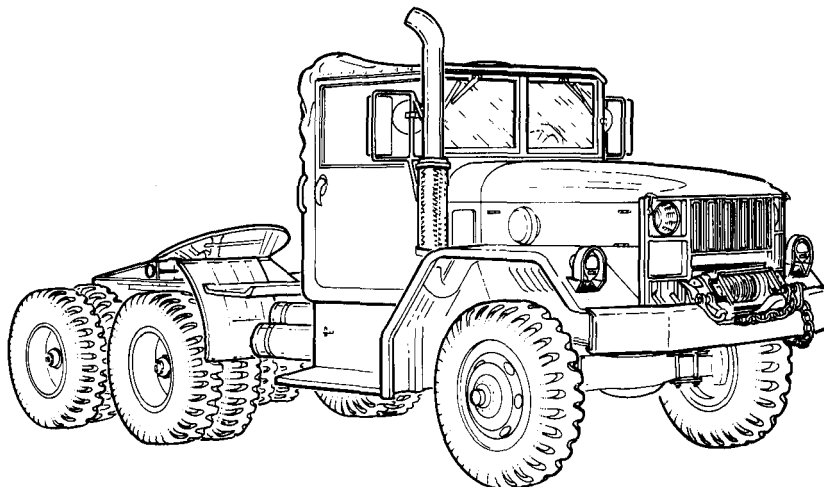

**M275A2 TRACTOR TRUCK**

**1-10. EQUIPMENT CHARACTERISTICS, CAPABILITIES, AND FEATURES (Contd)**

**i. M342A2 Dump Truck, WO/W and W/W.**

PURPOSE: M342A2 dump truck is used to transport materials such as sand, gravel, and stone. The forward end of the welded steel body extends up and over the vehicle cab to protect it from damage during loading operations. A troop seat kit with covering may be installed for troop transport operations.

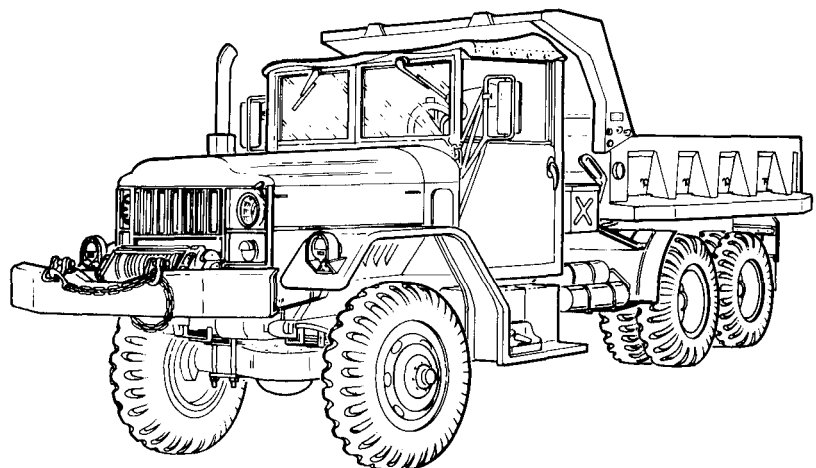

**M342A2 DUMP TRUCK W/W**

**j. M756A2 Pipeline Construction Maintenance Truck, W/W.**

PURPOSE: The M756A2 pipeline construction maintenance truck is used to load, unload, and transport pipe and pipeline construction equipment. An A-frame, side racks, bows, and tarpaulin are included with the vehicle. Side racks have built-in troop seats for transporting pipeline construction personnel. Both side panels may be removed for side mounting of A-frame. All vehicles have a winch mounted behind the cab for lifting pipes and a second winch mounted on the front of vehicle for recovery operations.

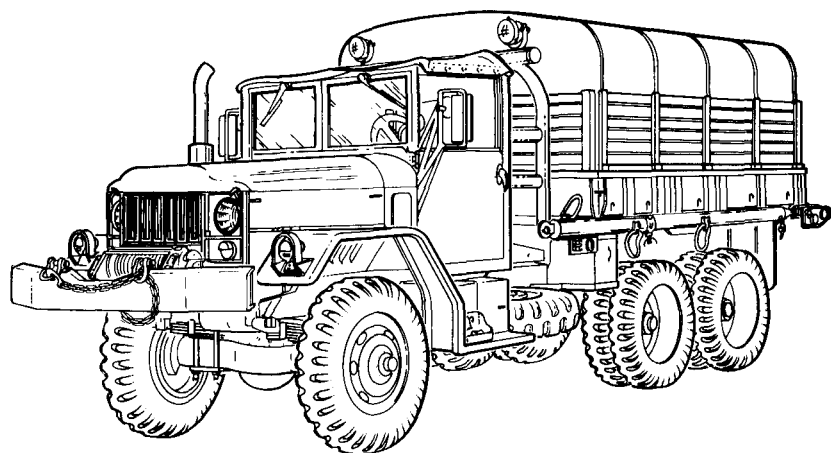

**M756A2 PIPELINE CONSTRUCTION MAINTENANCE TRUCK WW**

**1-10. EQUIPMENT CHARACTERISTICS, CAPABILITIES, AND FEATURES (Contd)****k. M764 Earth Boring and Polesetting Maintenance Truck, W/W.**

PURPOSE: M764 earth boring and polesetting maintenance truck uses an auger to bore holes and a derrick and rear winch to set and pull poles. A collapsible cable reel is used to lay wire and light cable. Hydraulically-operated outriggers are used to steady vehicle for earth boring and polesetting operations.

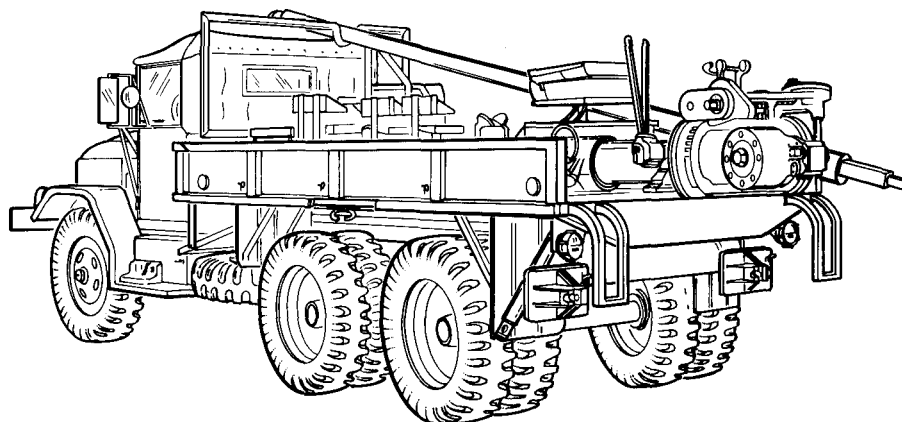

**M764 EARTH BORING AND POLESETTING MAINTENANCE TRUCK W/W**

## 1-11. LOCATION AND DESCRIPTION OF MAJOR EXTERNAL COMPONENTS

The exterior components described below are common to most of the vehicles covered in this manual. Special differences can be found in TM 9-2320-361-10 or table 1-1 of this manual.

- (A) ENGINE** - Provides power for the vehicle.
- (B) LIFTING TIEDOWN SHACKLES** - Used for lifting the vehicle in ship-to-shore operations and for tiedown attachments when transporting vehicle.
- (C) FRONT WINCH** - Used for recovery operations, powered by a propeller shaft extending from transmission power takeoff.
- (D) PRIMARY FUEL FILTER** - Filters contaminants from fuel.
- (E) AIR CLEANER** - Filters air before it enters the intake manifold.
- (F) TRANSMISSION** - Transmits engine power to transfer case.
- (G) FRONT PROPELLER SHAFT** - Transmits engine power from transfer case to front differential.
- (H) FUEL TANK** - Stores fuel.
- (I) REAR PROPELLER SHAFT(S)** - Transmits engine power from transmission to transfer case and then to rear differentials.
- (J) REAR BOGIE** - Suspension system that supports rear vehicle weight.
- (K) TOWING PINTLE HOOK** - Permits towing of vehicles or equipment.
- (L) REAR DIFFERENTIALS** - Transmits power from propeller shaft to axles.
- (M) AIR RESERVOIRS** - Storage tank(s) for compressed air.
- (N) SPARE TIRE CARRIER** - Stores spare tire.
- (O) TRANSFER POWER TAKEOFF** - Supplies power to drive pump for water and fuel tank vehicles, earth boring auger, and rear winch.
- (P) TRANSFER CASE** - The two-speed transfer case along with five forward speed transmission provides 10 speed ranges to front and rear differentials.
- (Q) AIR-HYDRAULIC CYLINDER** - Air-hydraulic cylinder increases fluid pressure to the wheel cylinders. The wheel cylinders expand and press the brakeshoes against the drum to slow or stop the vehicle.
- (R) MASTER CYLINDER** - Stores brake fluid in reservoir and supplies hydraulic pressure to displace fluid into the brake system. The master cylinder also compensates for seepage from the system.
- (S) TRANSMISSION POWER TAKEOFF** - Supplies power to drive front winch on all vehicles. Dump vehicles have a double-ended unit on left side of transmission. The forward output shaft is used to drive front winch. The rear accessory drive shaft drives the hydraulic pump for the dump vehicle.
- (T) SECONDARY AND FINAL FUEL FILTERS** - Filters fuel from primary fuel filter before fuel enters fuel injection pump.

1-11. LOCATION AND DESCRIPTION OF MAJOR EXTERNAL COMPONENTS (Contd)

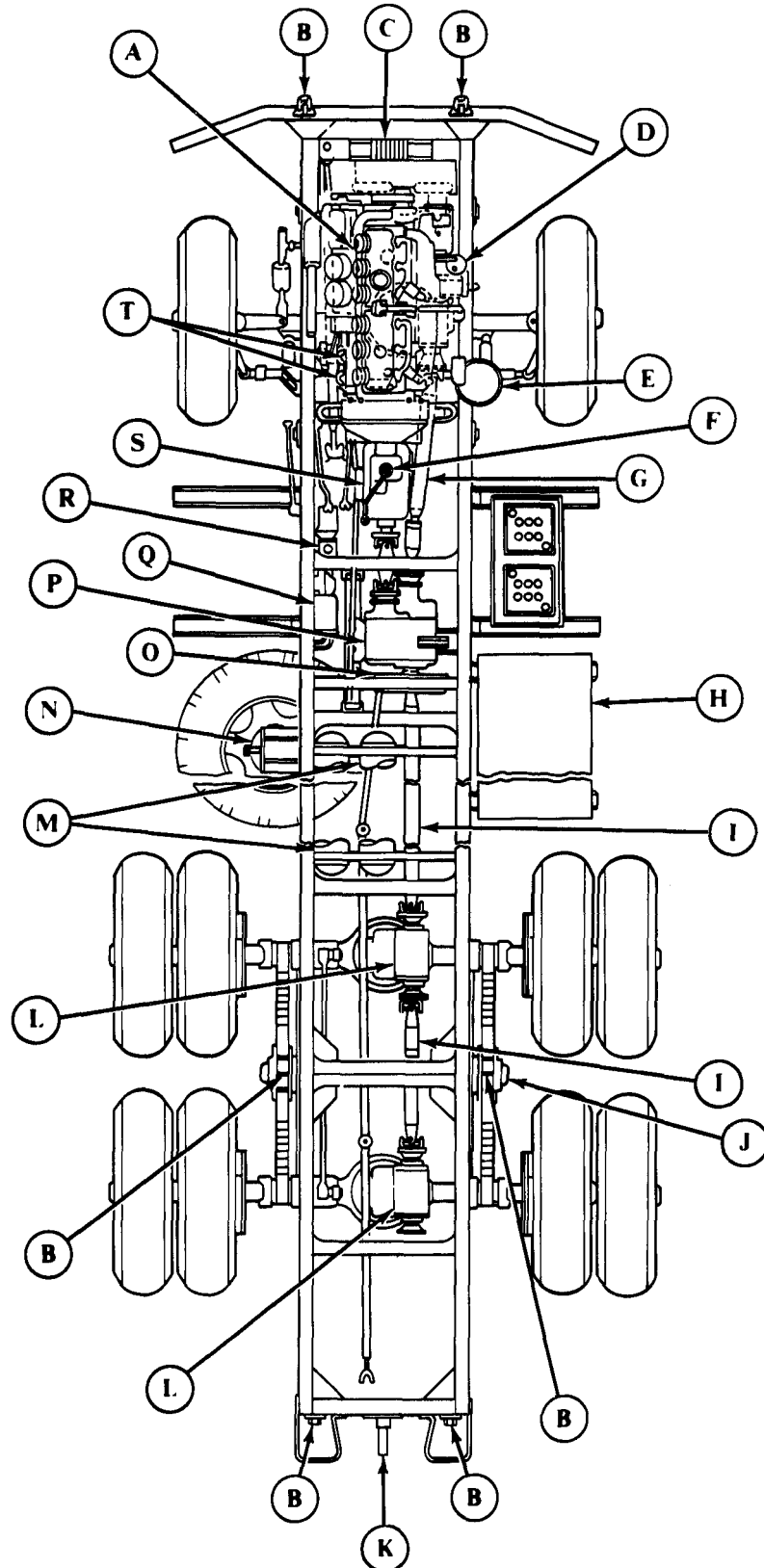



## 1-12. LOCATION AND DESCRIPTION OF MAJOR INTERNAL COMPONENTS

The major interior components shown below are common to one or more models covered by this manual. Components not covered here are found in TM 9-2320-361-10 or the applicable maintenance chapters of this manual.

- (A) STEERING WHEEL** - Manual control for turning vehicle.
- (B) TRANSMISSION GEARSHIFT LEVER** - Is used to shift transmission into 1 through 5, neutral, or reverse driving gears. Vehicle must be fully stopped before shifting from 2nd to 1st gear or into reverse. First and reverse have no synchronizing gears.
- (C) COWL VENTILATION** - When open, allows air flow into the driver's compartment.
- (D) POWER DIVIDER CONTROL LEVER** - Used on earth boring and polesetting vehicles for driving either the earth auger or rear winch on the polesetter. The rear winch direction is reversed with this lever. Driving power is provided by transfer case power takeoff (PTO). The transfer case shift lever must be in neutral and transmission gearshift in drive (1 through 3 or reverse).
- (E) TRANSFER CASE SHIFT LEVER** - Used on all vehicles to change ratio of driving power to axles and wheels. Lever is pulled up for HIGH range (greater speed and lower power) or down for LOW range (lower speed and higher power). This shift lever is placed in neutral to allow the transfer PTO lever to be engaged while preventing drive power to axles and wheels.
- (F) DRIVER'S SEAT** - One crewmember adjustable seat.
- (G) TRANSFER POWER TAKEOFF LEVER** - Place in UP position to provide driving power to earth boring auger or rear winch. The transfer case shift lever must be in neutral to prevent driving power to axles and wheels before this lever can be engaged.
- (H) PARKING BRAKE LEVER** - Pulled up to apply parking brake. The knob at the top of the handle is turned clockwise to increase brake cable tension.
- (I) HINGE LOCK** - Locks transmission PTO lever in neutral (N) position.
- (J) TRANSMISSION POWER TAKEOFF LEVER** - Provides two-speed and reverse driving power to front winch. Neutral positions are used between each drive and reverse positions. Input power is available to the transmission PTO when clutch is engaged and engine is running. Transmission is normally placed in neutral (N) when driving power is applied to the front winch.
- (K) REAR WINCH HINGE LOCK** - Locks rear winch lever in up (disengaged) position.
- (L) REAR WINCH CONTROL LEVER** - A two-position lever to engage or disengage drive to rear winch. The transfer case shift lever must be in neutral and transmission gearshift in drive (1 through 3 or reverse).
- (M) ACCELERATOR PEDAL** - Foot control for determining engine speed.
- (N) CLUTCH PEDAL** - Is depressed to disengage engine from transmission and allows shifting to different gear ratio. When clutch pedal is released, engine engages transmission.
- (O) SERVICE BRAKE PEDAL** - Foot control for stopping vehicle.
- (P) HYDRAULIC HOIST LEVER** - Control lever for raising and lowering dump body. Driving power to the hydraulic pump is supplied by the transmission PTO.
- (Q) INSTRUMENT CLUSTER** - Contains indicators to show engine performance.

1-12. LOCATION AND DESCRIPTION OF MAJOR INTERNAL COMPONENTS (Contd)

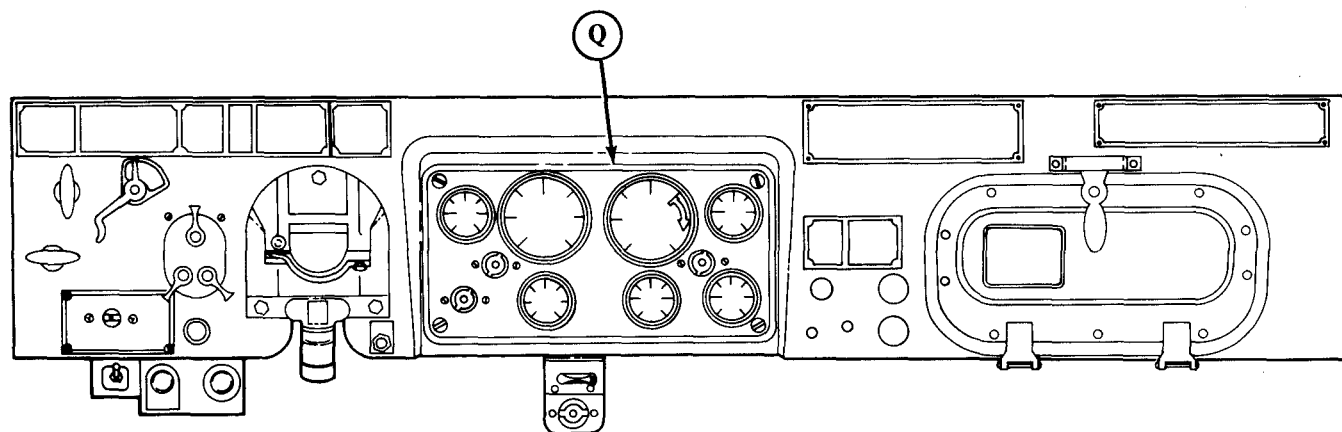
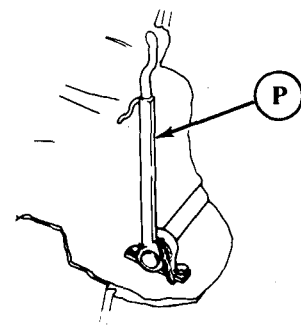
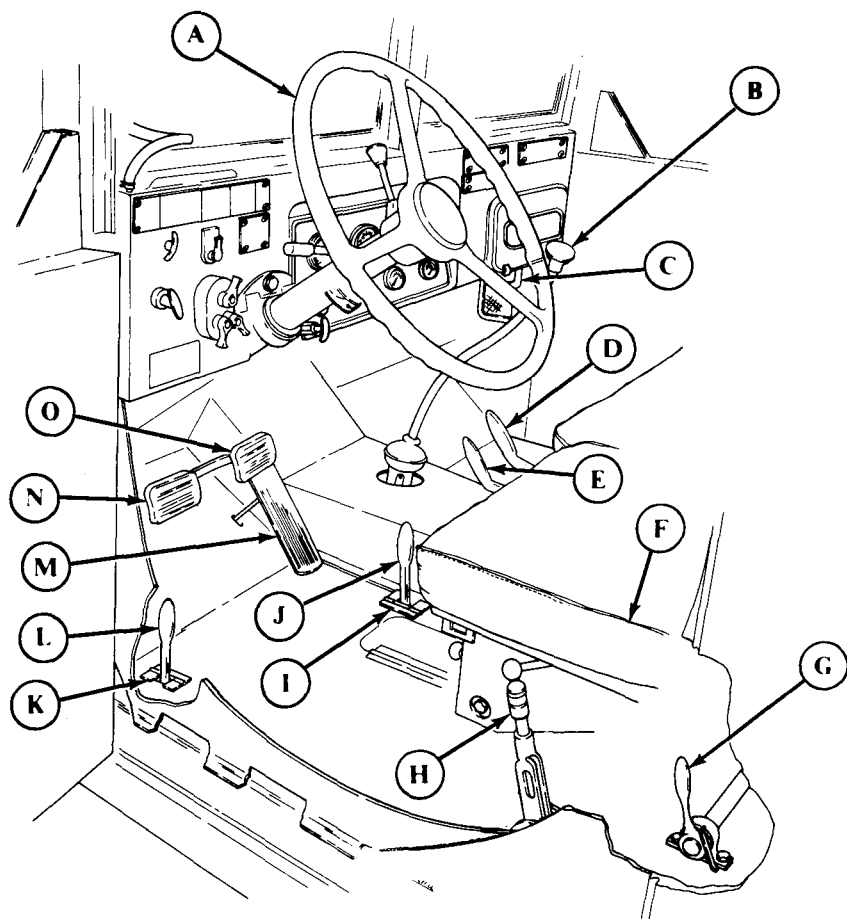

**1-13. LOCATION AND CONTENTS OF WARNING, CAUTION, AND DATA PLATES**

a. The location and contents of warning, caution, and data plates are provided in this paragraph. A complete list and location of all warning, caution, and data plates is in TM 9-2320-361-20P. If any of these plates are worn, broken, painted over, missing, or unreadable, they must be replaced.

b. Below are those plates that are located inside the cab. These plates are common to one or more models covered in this manual.

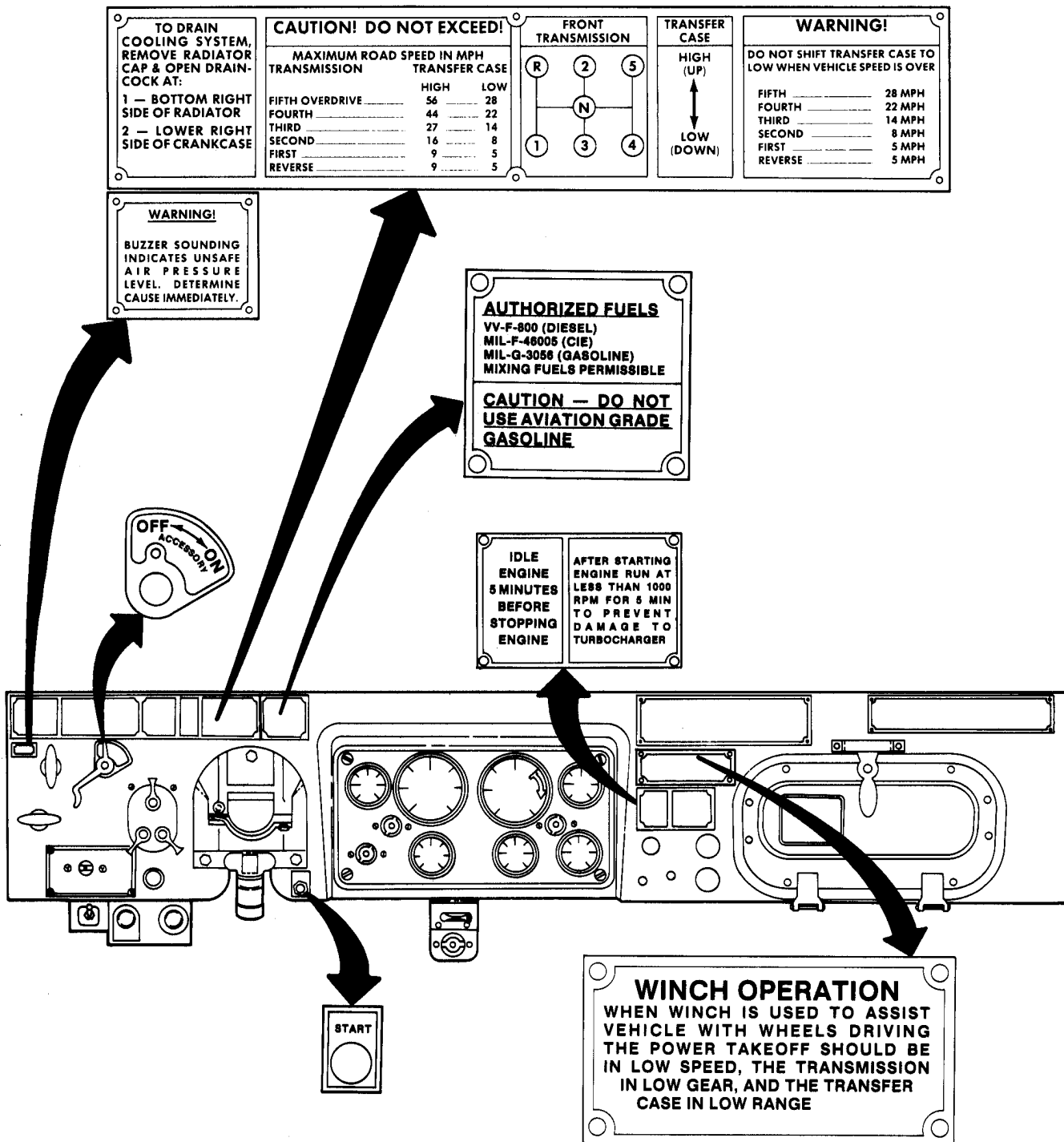

**1-13. LOCATION AND CONTENTS OF WARNING, CAUTION, AND DATA PLATES (Contd)**

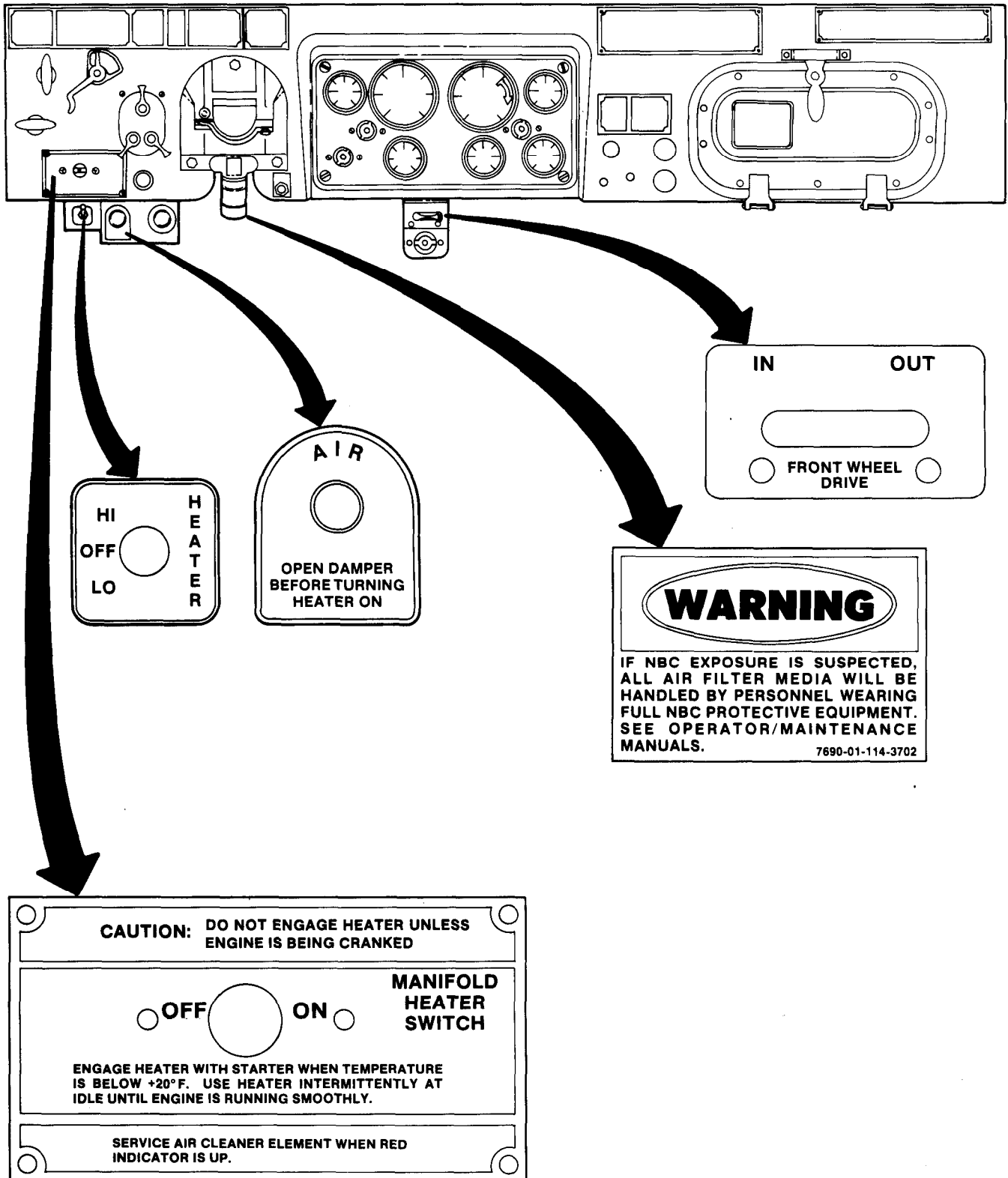

**1-13. LOCATION AND CONTENTS OF WARNING, CAUTION, AND DATA PLATES (Contd)**

<b>TRUCK, CARGO, DROP SIDE: 2-1/2 TON, 6X6, M35A2C W/W</b>				<b>IDENTIFICATION DATA</b>																														
<b>WEIGHT &amp; DIMENSION DATA</b>				STOCK NO.	2320-926-0875																													
C.G. LOCATION BASED ON 5,000 LBS. PAYLOAD W/O CREW 				<table border="1"> <tr> <th>WEIGHTS W/O CREW</th> <th>EMPTY</th> <th>CROSS CENTRY</th> <th>HIGH-WAY</th> </tr> <tr> <td>PAYLOAD</td> <td></td> <td>5,000</td> <td>10,000</td> </tr> <tr> <td>FRONT AXLE</td> <td>6,450</td> <td>6,646</td> <td>6,842</td> </tr> <tr> <td>INTER AXLE</td> <td>3,540</td> <td>5,942</td> <td>8,344</td> </tr> <tr> <td>REAR AXLE</td> <td>3,540</td> <td>5,942</td> <td>8,344</td> </tr> <tr> <td>TOTAL LBS</td> <td>13,530</td> <td>18,530</td> <td>23,530</td> </tr> <tr> <td>MAX TOWED LOAD LBS</td> <td></td> <td>6,000</td> <td>10,000</td> </tr> </table>	WEIGHTS W/O CREW	EMPTY	CROSS CENTRY	HIGH-WAY	PAYLOAD		5,000	10,000	FRONT AXLE	6,450	6,646	6,842	INTER AXLE	3,540	5,942	8,344	REAR AXLE	3,540	5,942	8,344	TOTAL LBS	13,530	18,530	23,530	MAX TOWED LOAD LBS		6,000	10,000	IDENTIFICATION NO.	
WEIGHTS W/O CREW	EMPTY	CROSS CENTRY	HIGH-WAY																															
PAYLOAD		5,000	10,000																															
FRONT AXLE	6,450	6,646	6,842																															
INTER AXLE	3,540	5,942	8,344																															
REAR AXLE	3,540	5,942	8,344																															
TOTAL LBS	13,530	18,530	23,530																															
MAX TOWED LOAD LBS		6,000	10,000																															
LOADED CG BASED ON LOAD OF UNIFORM DENSITY COMPLETELY FILLING BODY SHIPPING CUBAGE 1,252 CU. FT.				MFD. BY																														
				CONTRACT NO.																														
				U.S. PROPERTY																														

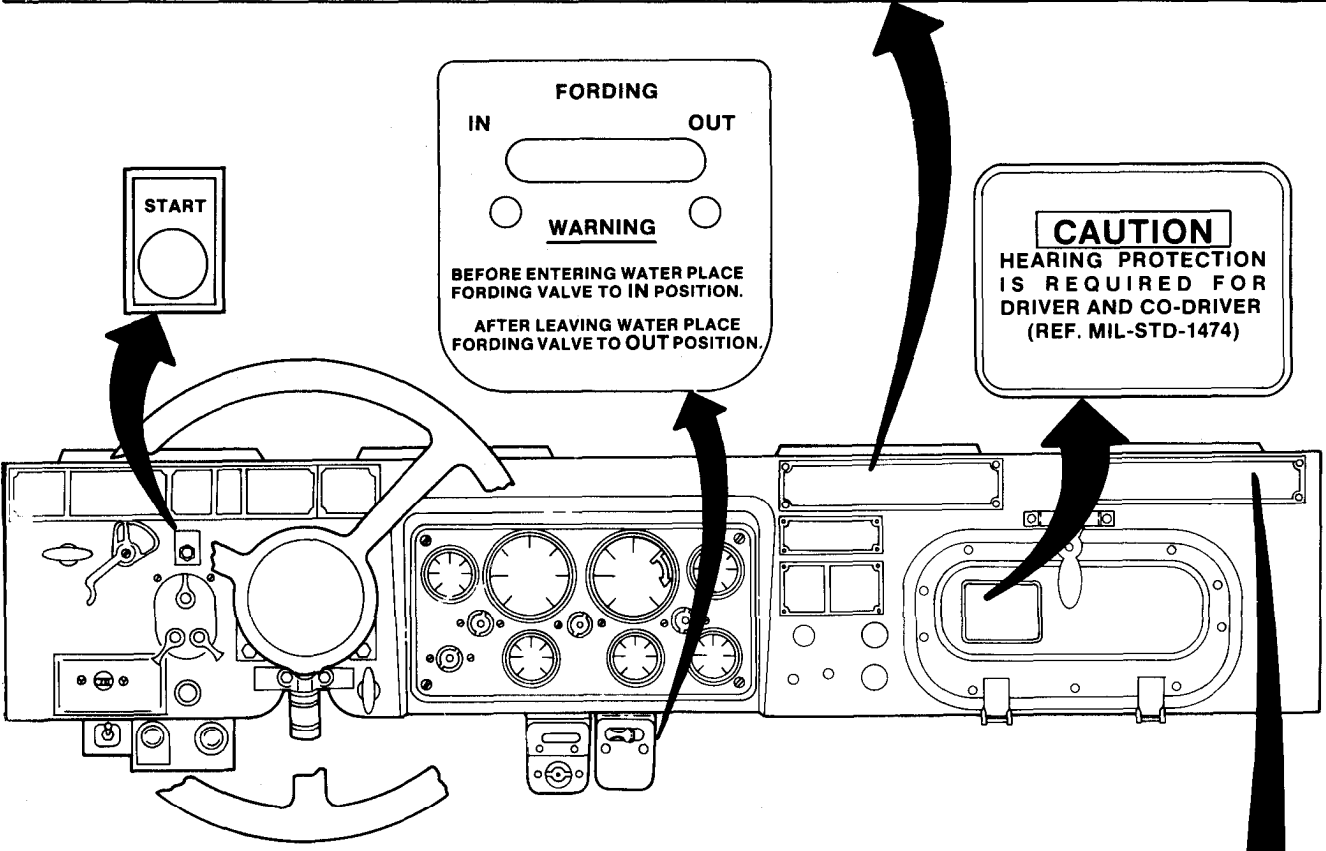

**NOTE**

TM 9-2320-209 publications, listed on data plate, apply only to M44 and M44A1 vehicles. TM 9-2320-361 publications supersede TM 9-2320-209 publications for M44A2 vehicles only.

<b>SERVICING DATA</b>		<b>TRUCK, 2-1/2 TON 6 X 6</b>				<b>PUBLICATIONS APPLYING TO THIS VEHICLE</b>	
<b>ELECTRICAL SYSTEM 24V</b>		<b>TIRE INFLATION PRESSURES</b>		<b>11:00 SINGLE — TIRES — 9:00 DUALS</b>			
CRANKCASE CAPACITY	22 QTS.			2-1/2 TON—5-TON	PAYLOAD	2-1/2 TON—5-TON	
COOLING SYSTEM CAPACITY	32 QTS.	HIGHWAY	50 LBS. 50 LBS.				OPERATOR'S MANUAL — TM 9-2320-209-10
FUEL TANK CAPACITY	50 GAL.	CROSS COUNTRY	35 LBS.				LUBRICATION ORDER — LO 9-2320-209-12
		MUD, SAND, SNOW	15 LBS.				MAINTENANCE MANUAL — TM 9-2320-209-20
<b>TEMPERATURE</b>	<b>ENGINE OIL</b>	<b>GEAR OIL</b>	<b>GREASE</b>				PARTS LIST — TM 9-2320-209-20P
ABOVE 32° F	OE GRADE S.A.E. 30	GO GRADE 90	SEE LUBRICATION ORDER				
40° F TO -10° F	OE GRADE S.A.E. 10	GO GRADE 90	NO. LO 9-2320-209-12				
0° F TO -65° F	SEE LUBRICATION ORDER NO. LO 9-2320-209-12						

1-13. LOCATION AND CONTENTS OF WARNING, CAUTION, AND DATA PLATES (Contd)

**WARNING**  
DO NOT USE WINCH TO  
PAY OUT LINE LOADS  
GREATER THAN 3000  
LBS FOR ANY DISTANCE  
GREATER THAN 10 FT.

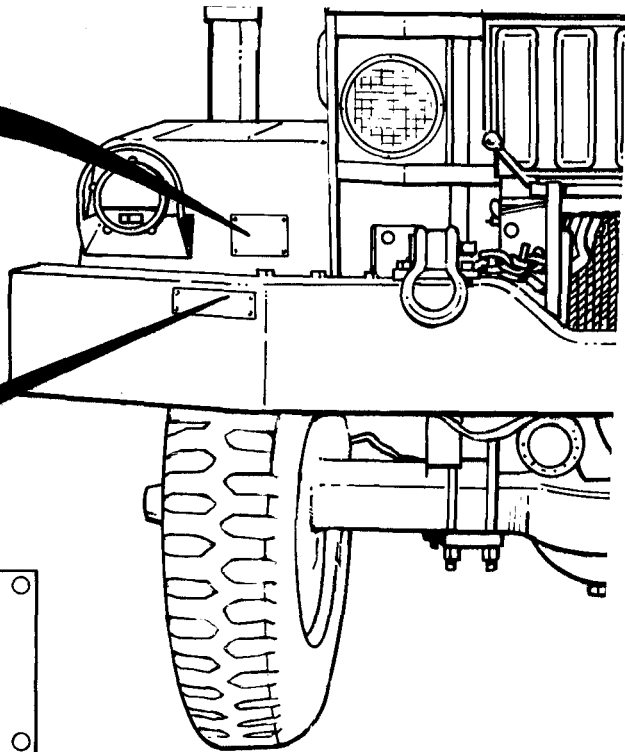

**WINCH CABLE & SNATCH BLOCK RATINGS**  
SAFE WORKING LOADS  
6,100 LBS FOR SINGLE LINE 1/2" DIA CABLE  
12253105-11; 10,000 LBS FOR HOOK OF  
SNATCH BLOCK 11631700

**WINCH CABLE**  
— HI WIND  
— NEU  
— LOW  
■ NEU  
— REV  
UNWIND

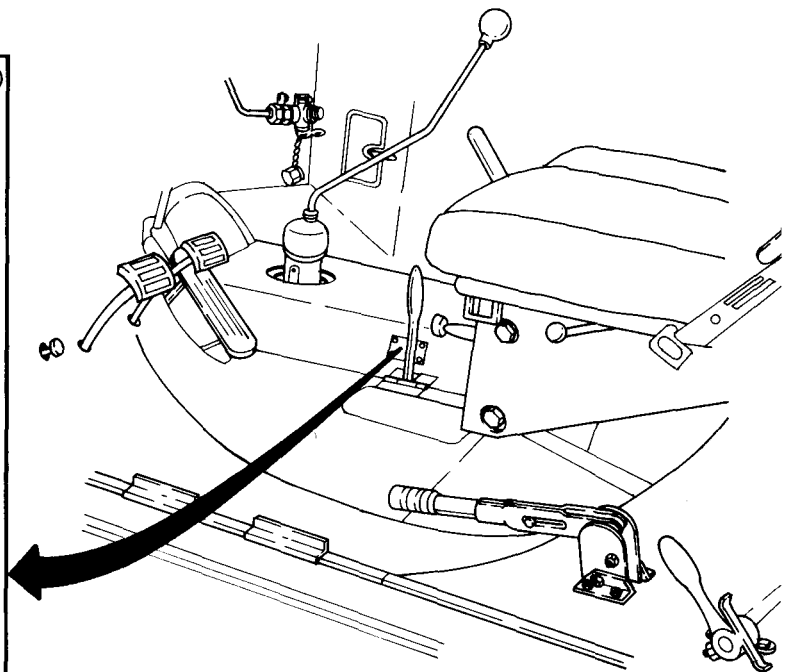

**1-13. LOCATION AND CONTENTS OF WARNING, CAUTION, AND DATA PLATES (Contd)**

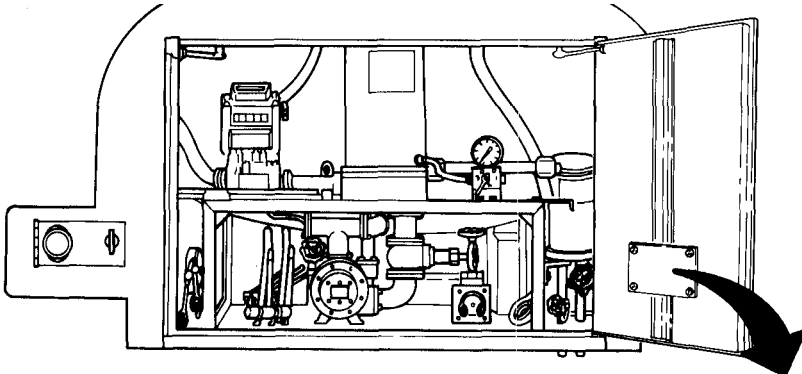

**FOR PARTS REQUISITION IDENTIFICATION**

MFG'S. SERIAL NO. \_\_\_\_\_  
 GOV. CONTRACT NO. \_\_\_\_\_

NOMINAL TANK LENGTH 152" WIDTH 96"

**OPERATING INSTRUCTIONS**  
 EACH OPERATION BEGINS WITH ALL VALVES CLOSED

**CAUTION** PRIOR TO FUEL TRANSFER

(1) **STATIC DISCHARGE**  
 (A) CLIP WIRE FROM STATIC DISCHARGE REEL ON SERVICING TRUCK TO GROUND ROD (TRUCK TO GROUND)  
 (B) ENSURE UNIT REQUIRING SERVICE IS GROUNDED (UNIT OR AIRCRAFT TO GROUND)  
 (C) GROUND SERVICING TRUCK TO UNIT OR AIRCRAFT REQUIRING SERVICE  
 (D) GROUND REFUELING NOZZLE TO UNIT OR AIRCRAFT.  
 STEPS (A) THROUGH (D) ABOVE MUST BE ACCOMPLISHED BEFORE REMOVAL OF FILLER CAPS ON UNIT OR AIRCRAFT TO BE SERVICED.

(2) **DO NOT CARRY MORE THAN ONE TYPE OF FUEL AT ONE TIME**  
 SEE APPLICABLE TECHNICAL ORDER FOR CHANGING FROM ONE TYPE OF FUEL TO ANOTHER TYPE FOR SERVICING PURPOSES.

(3) **TO DISCHARGE FROM TANK THRU PUMP**  
 (SEE GROUNDING PROCEDURE ABOVE)  
 (A) START ENGINE. POSITION TRANSMISSION IN SECOND GEAR. PLACE TRANSFER IN NEUTRAL. ENGAGE POWER TAKEOFF. PULL-OUT THROTTLE CONTROL SLOWLY TO EXTREME POSITION. SPEED CONTROL UNIT WILL CONTROL ENGINE AT 1150 RPM.  
 (B) OPEN DESIRED TANK COMPARTMENT DISCHARGE VALVE BY MOVING CORRESPONDING CONTROL LEVER TO OPEN POSITION.  
 (C) TURN DELIVERY LINE GATE VALVE TO OPEN POSITION.  
 (D) DISCHARGE THRU HOSE BY OPENING NOZZLE.

(4) **TO FILL TANK OR TRANSFER LIQUID FROM ONE SOURCE TO ANOTHER THRU PUMP**  
 (SEE GROUNDING PROCEDURE ABOVE)  
 (A) ATTACH SUCTION HOSE (ONE OR BOTH 10 FOOT SECTIONS) TO ADAPTER AT SUCTION LINE GATE VALVE.  
 (B) REPEAT (3)(A) ABOVE.  
 (C) PLACE END OF SUCTION HOSE INTO SOURCE.  
 (D) TURN SUCTION AND DELIVERY LINE GATE VALVES TO OPEN POSITION.  
 (E) DISCHARGE THRU HOSE INTO TANK TO BE FILLED. BY OPENING NOZZLE.

NOTE PERFORM DIFFERENTIAL PRESSURE CHECK DURING FUELING OPERATION.

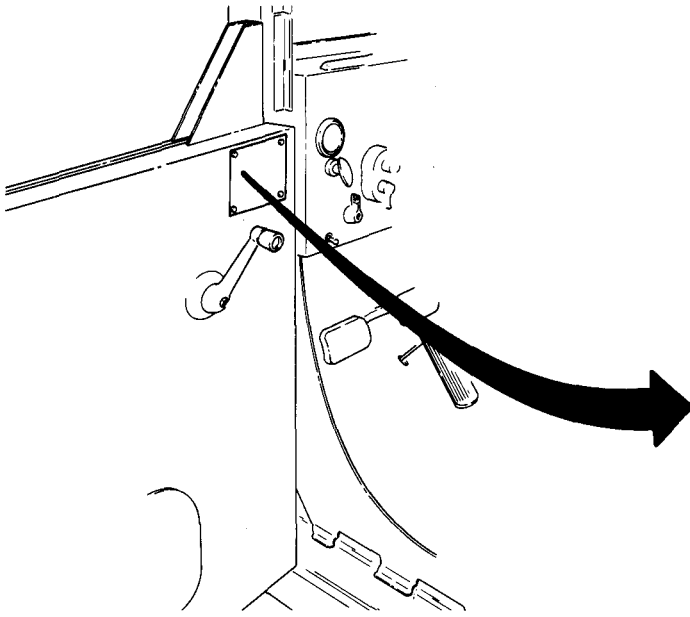

**CAUTION**

TO DIRECT HEAT TO WATER TANK

1. CLOSE FRONT EXHAUST STACK SHUTOFF CAP.
2. OPEN WATER TANK EXHAUST SHUTOFF (TURN HANDLE COUNTERCLOCKWISE TO OPEN).

TANK EXHAUST HEATER MUST NOT BE OPERATED WITH LESS THAN 10 INCHES OF WATER IN EITHER TANK COMPARTMENT AND VEHICLE MUST NOT BE OPERATED WITH BOTH EXHAUST SHUTOFFS CLOSED.

SERIOUS DAMAGE MAY RESULT IF THESE WARNINGS ARE NOT OBSERVED.

## 1-13. LOCATION AND CONTENTS OF WARNING, CAUTION, AND DATA PLATES (Contd)

**—OPERATING INSTRUCTIONS—**

ORDNANCE NO. 10937246  
AUTOMATIC WATER DRAIN  
THIS UNIT WILL AUTOMATICALLY COLLECT AND DISCHARGE  
WATER WHICH HAS BEEN REMOVED FROM THE FUEL BY  
THE COMBINATION FUEL MONITOR FILTER WATER SEPARATOR.

AN INTERNAL FLOAT VALVE ASSEMBLY ARMY NO. 10947552  
AUTOMATICALLY DISCHARGES WATER THROUGH THE 1" VALVE  
LOCATED ON THE BOTTOM OF THIS UNIT. THIS 1" VALVE  
SHOULD BE OPEN DURING FUELING OPERATIONS.

THE 1/2" VALVE (MANUAL DRAIN VALVE) SHOULD BE  
OPENED PERIODICALLY TO DRAIN THE SUMP ASSEMBLY.

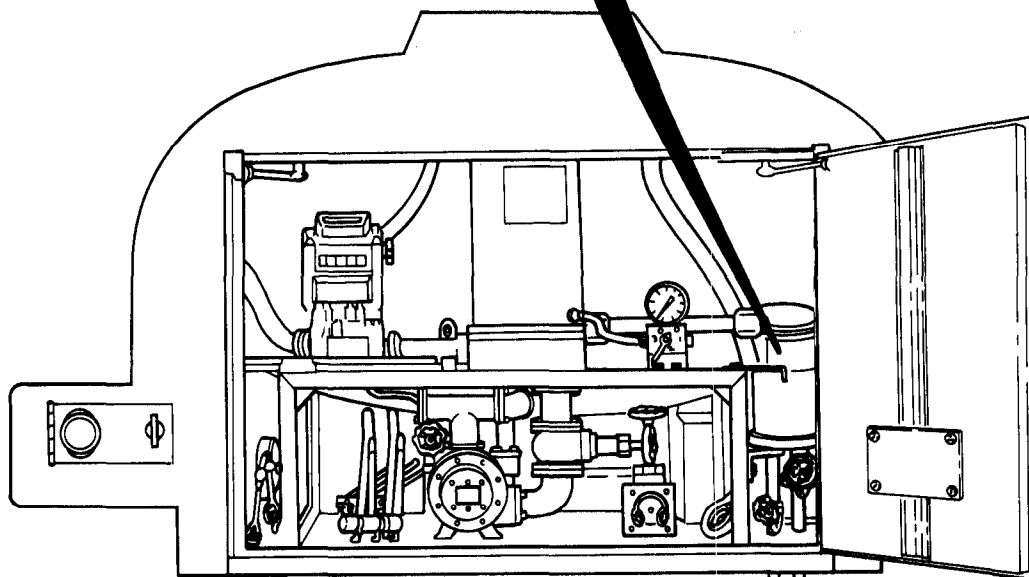



**1-13. LOCATION AND CONTENTS OF WARNING, CAUTION, AND DATA PLATES (Contd)**

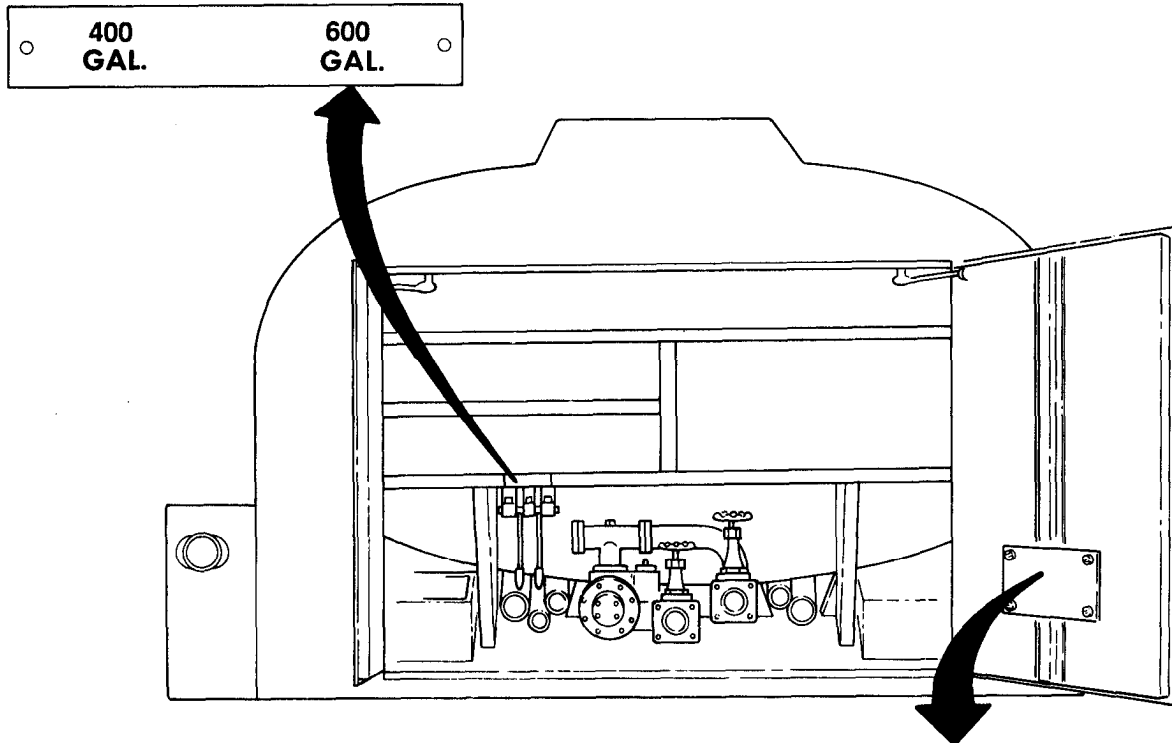

**FOR PARTS REQUISITION IDENTIFICATION**

MFG'S. SERIAL NO.

GOV. CONTRACT NO.

NOMINAL TANK LENGTH 148" WIDTH 96"

**OPERATING INSTRUCTIONS**

**EACH OPERATION BEGINS WITH ALL VALVES CLOSED**

- (1) **TO DISCHARGE FROM TANK BY GRAVITY**
  - (A) ATTACH 2" X 1-1/2" BUSHING TO SUCTION STUB.
  - (B) ATTACH 1-1/2" DISCHARGE HOSE W/ OR W/O NOZZLE AS DESIRED.
  - (C) OPEN TANK OUTLET VALVE LEVER AND SUCTION VALVE.
  - (D) DISCHARGE THROUGH HOSE BY OPENING NOZZLE IF ATTACHED.
- (2) **TO DISCHARGE FROM TANK THROUGH PUMP**
  - (A) ATTACH 2" X 1-1/2" BUSHING TO DISCHARGE STUB.
  - (B) ATTACH 1-1/2" DISCHARGE HOSE W/ OR W/O NOZZLE AS DESIRED.
  - (C) OPEN TANK OUTLET LEVER AND DISCHARGE VALVE.
  - (D) START ENGINE, POSITION TRANSMISSION IN FOURTH GEAR, POSITION TRANSFER IN NEUTRAL, ENGAGE POWER TAKEOFF, PULL OUT THROTTLE CONTROL SLOWLY TO EXTREME POSITION. SPEED CONTROL UNIT WILL CONTROL ENGINE AT 1100 RPM.
- (3) **TO FILL TANK FROM OUTSIDE SOURCE OR TRANSFER LIQUID FROM ONE SOURCE TO ANOTHER**
  - (A) ATTACH 2" SOCKET HOSE TO SUCTION STUB.
  - (B) PLACE END OF SUCTION HOSE W/ STRAINER ATTACHED INTO SOURCE.
  - (C) ATTACH 2" X 1-1/2" BUSHING TO DISCHARGE STUB.
  - (D) ATTACH 1-1/2" DISCHARGE HOSE W/ OR W/O NOZZLE AS DESIRED.
  - (E) PLACE END OF DISCHARGE HOSE INTO TANK TO BE FILLED.
  - (F) OPEN SUCTION AND DISCHARGE VALVES.
  - (G) REPEAT PROCEDURE (2D) AS NOTED ABOVE.
- (4) **TO FILL TANK FROM HYDRANT**
  - (A) ATTACH 2-1/2" X 1-1/2" BUSHING TO HYDRANT.
  - (B) ATTACH 1-1/2" DISCHARGE HOSE W/ OR W/O NOZZLE AS DESIRED.
  - (C) PLACE END OF DISCHARGE HOSE INTO TANK.
  - (D) OPEN HYDRANT VALVE WITH WRENCH PROVIDED.
  - (E) DISCHARGE THROUGH HOSE BY OPENING NOZZLE IF ATTACHED.
- (5) **TO OPERATE TWO DISCHARGE LINES**
  - (A) ATTACH SIAMESE FITTING OR ONE END OF LENGTH OF HOSE WITH SIAMESE FITTING ON OTHER END TO DISCHARGE STUB AND COUPLE ADDITIONAL LENGTH OF HOSE TO SIAMESE FITTING.

**CAUTION**

- (6) **PARKING TANK DURING FREEZING**
  - (A) CLOSE TANK VALVE LEVERS, OPEN SUCTION AND DISCHARGE VALVES, PROTECTOR CAPS TO BE LEFT OFF
  - (B) RUN PUMP 80 SECONDS TO DRAIN PIPES DRY
- (7) **CHECK WATER LEVEL BEFORE LIGHTING HEATER**
  - (A) WHEN IMMERSION HEATER IS REQUIRED AS PART OF OPERATION, CHECK WATER LEVEL WITH GAGE STICK
  - (B) IF WATER LEVEL IS BELOW CAUTION MARK ON GAGE STICK, OR LESS THAN 9-3/16" FROM BOTTOM, DO NOT LIGHT HTR.

**1-13. LOCATION AND CONTENTS OF WARNING, CAUTION, AND DATA PLATES (Contd)**

○ 500 GAL. ○ 500 GAL. ○

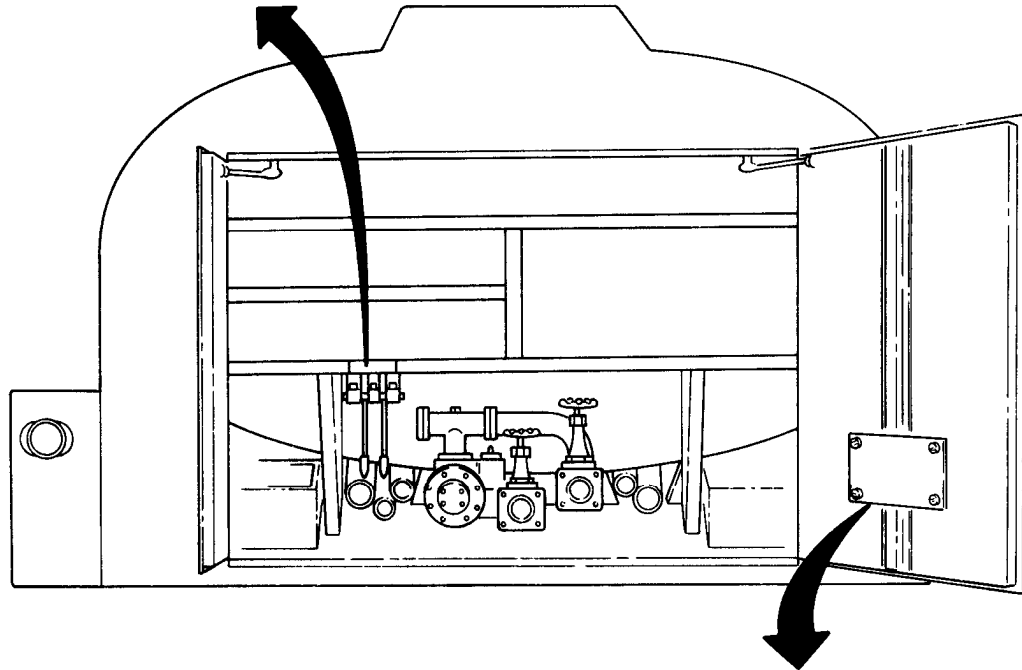

**FOR PARTS REQUISITION IDENTIFICATION**

MFG'S. SERIAL NO.

GOV. CONTRACT NO.

NOMINAL TANK LENGTH 148 WIDTH 96

**OPERATING INSTRUCTIONS**

**EACH OPERATION BEGINS WITH ALL VALVES CLOSED**

(1) **TO DISCHARGE FROM TANK BY GRAVITY**

- (A) ATTACH 2 X 1-1-2 BUSHING TO SUCTION STUB
- (B) ATTACH 1-1-2 DISCHARGE HOSE W OR W O NOZZLE AS DESIRED.
- (C) OPEN TANK OUTLET VALVE LEVER AND SUCTION VALVE.
- (D) DISCHARGE THROUGH HOSE BY OPENING NOZZLE IF ATTACHED.

(2) **TO DISCHARGE FROM TANK THROUGH PUMP**

- (A) ATTACH 2 X 1-1-2 BUSHING TO DISCHARGE STUB.
- (B) ATTACH 1-1-2 DISCHARGE HOSE W OR W O NOZZLE AS DESIRED.
- (C) OPEN TANK OUTLET LEVER AND DISCHARGE VALVE
- (D) START ENGINE. POSITION TRANSMISSION IN FOURTH GEAR. POSITION TRANSFER IN NEUTRAL. ENGAGE POWER TAKEOFF. PULL OUT THROTTLE CONTROL SLOWLY TO EXTREME POSITION. SPEED CONTROL UNIT WILL CONTROL ENGINE AT 1100 RPM

(3) **TO FILL TANK FROM OUTSIDE SOURCE OR TRANSFER LIQUID FROM ONE SOURCE TO ANOTHER**

- (A) ATTACH 2 SOCKET HOSE TO SUCTION STUB
- (B) PLACE END OF SUCTION HOSE W STRAINER ATTACHED INTO SOURCE
- (C) ATTACH 2 X 1-1-2 BUSHING TO DISCHARGE STUB
- (D) ATTACH 1-1-2 DISCHARGE HOSE W OR W O NOZZLE AS DESIRED.
- (E) PLACE END OF DISCHARGE HOSE INTO TANK TO BE FILLED.
- (F) OPEN SUCTION AND DISCHARGE VALVES
- (G) REPEAT PROCEDURE (2D)

(4) **TO FILL TANK FROM HYDRANT**

- (A) ATTACH 2-1-2 X 1-1-2 BUSHING TO HYDRANT.
- (B) ATTACH 1-1-2 DISCHARGE HOSE W OR W O NOZZLE AS DESIRED
- (C) PLACE END OF DISCHARGE HOSE INTO TANK.
- (D) OPEN HYDRANT VALVE WITH WRENCH PROVIDED
- (E) DISCHARGE THROUGH HOSE BY OPENING NOZZLE IF ATTACHED

(5) **TO OPERATE TWO DISCHARGE LINES**

- (A) ATTACH SIAMESE FITTING OR ONE END OF LENGTH OF HOSE WITH SIAMESE FITTING ON OTHER END TO DISCHARGE STUB AND COUPLE ADDITIONAL LENGTH OF HOSE TO SIAMESE FITTING.

**CAUTION**

(6) **PARKING TANK DURING FREEZING**

- (A) CLOSE TANK VALVE LEVERS. OPEN SUCTION AND DISCHARGE VALVES. PROTECTOR CAPS TO BE LEFT OFF
- (B) RUN PUMP 60 SECONDS TO DRAIN PIPES DRY

(7) **CHECK WATER LEVEL BEFORE LIGHTING HEATER**

- (A) WHEN IMMERSION HEATER IS REQUIRED AS PART OF OPERATION. CHECK WATER LEVEL WITH GAGE STICK
- (B) IF WATER LEVEL IS BELOW CAUTION MARK ON GAGE STICK OR LESS THAN 9-3-16 FROM BOTTOM. DO NOT LIGHT HTR

1-13. LOCATION AND CONTENTS OF WARNING, CAUTION, AND DATA PLATES (Contd)

**CAUTION**  
PULL OUT DRUM LOCK  
BEFORE OPERATING WINCH

**CAUTION**  
DO NOT TIGHTEN  
SAFETY BRAKE  
ADJUSTING BOLT  
MORE THAN NECESSARY  
TO HOLD LOAD

**WINCH CABLE & SNATCH BLOCK**  
RATING ON LEVEL SURFACE  
9,500 LBS FOR 5/8 DIA CABLE 12253105-13;  
11,500 LBS FOR HOOK OF SNATCH BLOCK 11631726

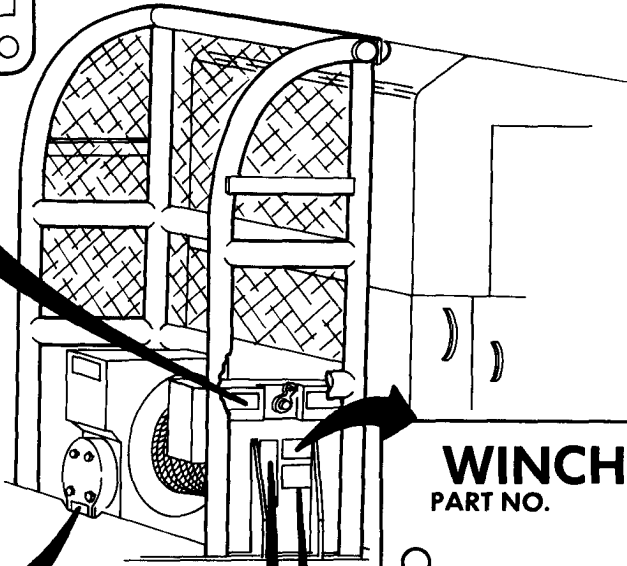

**WINCH ASSY**  
PART NO.  
MEDIUM DUTY  
MANUFACTURER  
SERIAL NO.

**WARNING**  
DO NOT WIND OUT CABLE  
WHEN ATTACHED TO LOAD.  
LOAD MUST BE WOUND IN  
ONLY.

**1-13. LOCATION AND CONTENTS OF WARNING, CAUTION, AND DATA PLATES (Contd)**

**WARNING**

1. NO UNAUTHORIZED PERSONNEL ALLOWED IN REAR OF VEHICLE DURING OPERATION OF WINCH.
2. AVOID CABLE WHEN OPERATING WINCH UNDER HEAVY LOAD.

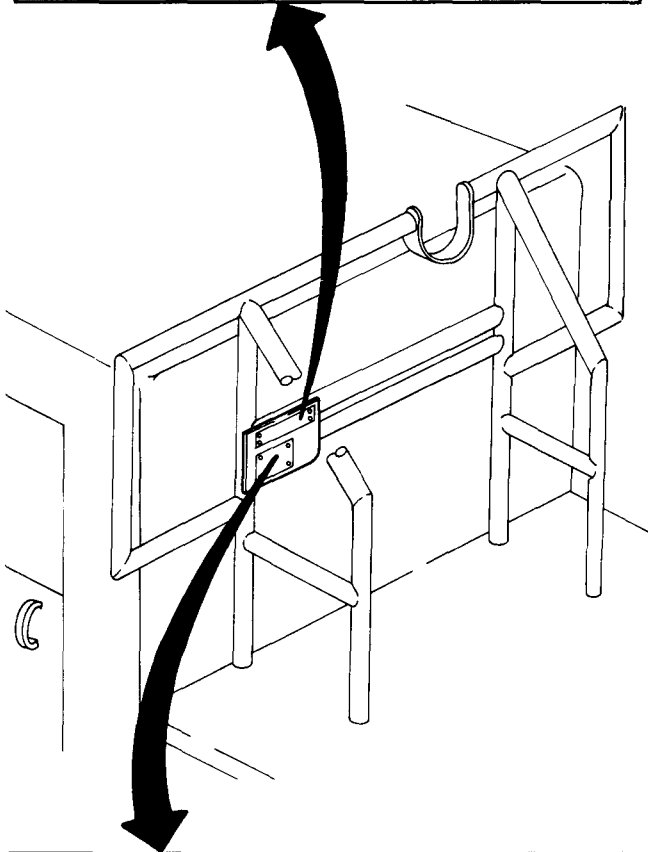

**REAR WINCH SHEAR PIN REPLACEMENT**

1. PLACE TRANSFER PTO IN NEUTRAL.
2. ROTATE DRIVE SPROCKET UNTIL SHEAR PIN HOLES ARE IN LINE.
3. REMOVE FAILED SHEAR PIN.
4. INSTALL NEW ALUMINUM SHEAR PIN (11609886) AND INSERT COTTER PINS IN EACH END OF SHEAR PIN.

**CAUTION**

BEFORE REPLACING SHEAR PIN RELIEVE CABLE TENSION IF POSSIBLE. IF LOAD IS SUSPENDED OBSERVE EXTREME CAUTION WHEN REPLACING SHEAR PIN.

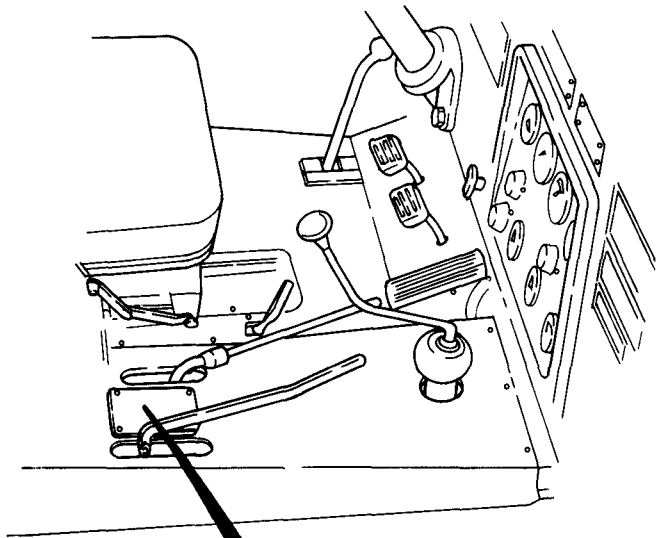

**POWER DIVIDER**

REAR WINCH FWD —

REAR WINCH REV. —

NEUTRAL —————

EARTH AUGER —————

1-13. LOCATION AND CONTENTS OF WARNING, CAUTION, AND DATA PLATES (Contd)

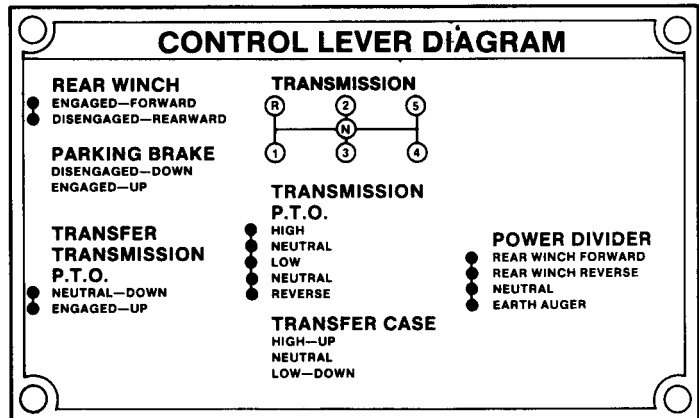

**WARNING**

1. NO UNAUTHORIZED PERSONNEL ALLOWED IN REAR OF VEHICLE DURING OPERATION OF WINCH.
2. AVOID CABLE WHEN OPERATING WINCH UNDER HEAVY LOAD.

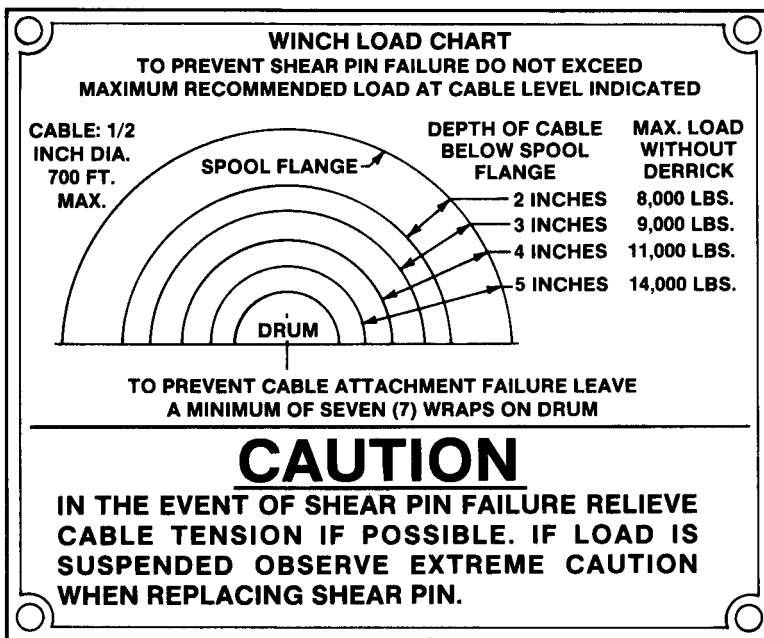

**WARNING**

EAR PROTECTION REQUIRED DURING OPERATION OF AUGER

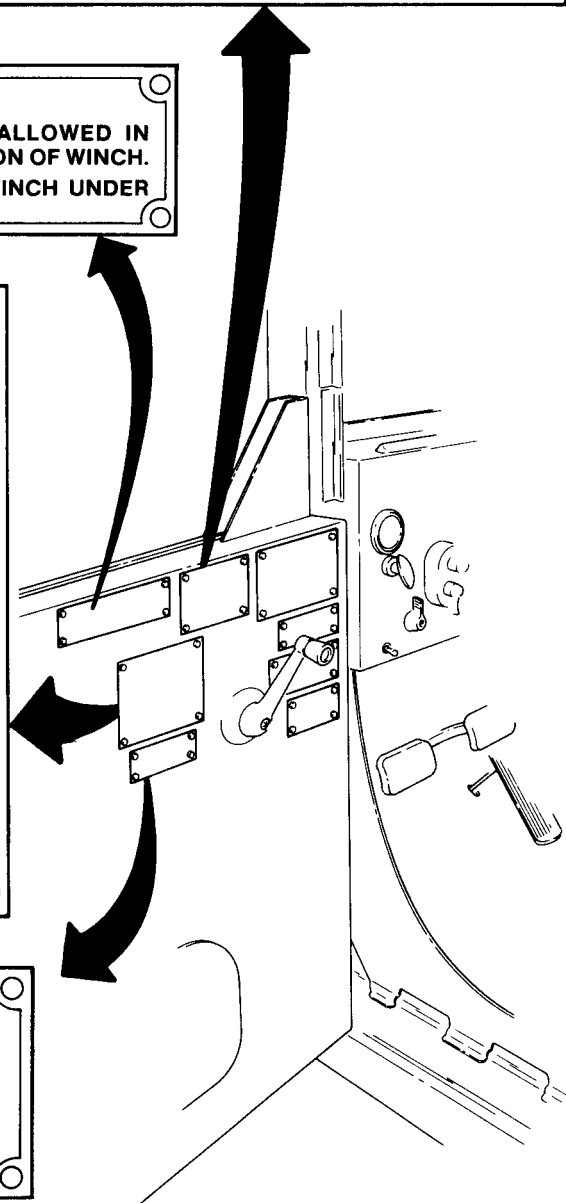

**1-13. LOCATION AND CONTENTS OF WARNING, CAUTION, AND DATA PLATES (Contd)**

<b>OPERATING PROCEDURE</b>	
<p><b>EARTH AUGER</b></p> <p>STEP 1. ENGAGE PARKING BRAKE. STEP 2. DISENGAGE VEHICLE CLUTCH. STEP 3. TRANSFER CASE — NEUTRAL. STEP 4. TRANSMISSION AVERAGE SOIL — 3RD GEAR HARD OR FROZEN SOIL — 2ND GEAR DISINTEGRATED SHALE — 1ST GEAR</p> <p>STEP 5. ENGAGE TRANSFER P.T.O. STEP 6. POWER DIVIDER — EARTH AUGER STEP 7. ENGAGE VEHICLE CLUTCH SLOWLY.</p> <p><b>MAXIMUM ENGINE SPEED</b> AVERAGE SOIL — 2,600 RPM HARD OR FROZEN SOIL — 2,400 RPM DISINTEGRATED SHALE — 1,800 RPM</p> <p><b>COLLAPSIBLE REEL CAPACITY</b> 3,000 LBS. DO NOT EXCEED.</p>	<p><b>REAR WINCH</b></p> <p>STEP 1. ENGAGE PARKING BRAKE. STEP 2. DISENGAGE VEHICLE CLUTCH. STEP 3. TRANSFER CASE — NEUTRAL. STEP 4. ENGAGE TRANSFER P.T.O. STEP 5. TRANSMISSION LOADS EXCEEDING 1,000 LBS. OR AWKWARD LOADS — 1ST GEAR LIGHT LOADS — 1ST, 2ND, OR 3RD GEAR</p> <p>STEP 6. ENGAGE REAR WINCH. STEP 7. POWER DIVIDER TO PLAY OUT CABLE — REVERSE TO TAKE UP CABLE — FORWARD</p> <p>STEP 8. ENGAGE VEHICLE CLUTCH.</p> <p><b>REAR WINCH CAPACITY</b> SEE WINCH LOAD CHART AND DERRICK LOAD CHART FOR MAXIMUM LINE PULL. REFER TO THE WINCH LOAD CHART WHEN THE DERRICK IS NOT USED DURING WINCH OPERATION.</p> <p><b>COLLAPSIBLE REEL</b> SAME AS REAR WINCH OPERATION EXCEPT STEP 7, REAR WINCH IS DISENGAGED.</p>

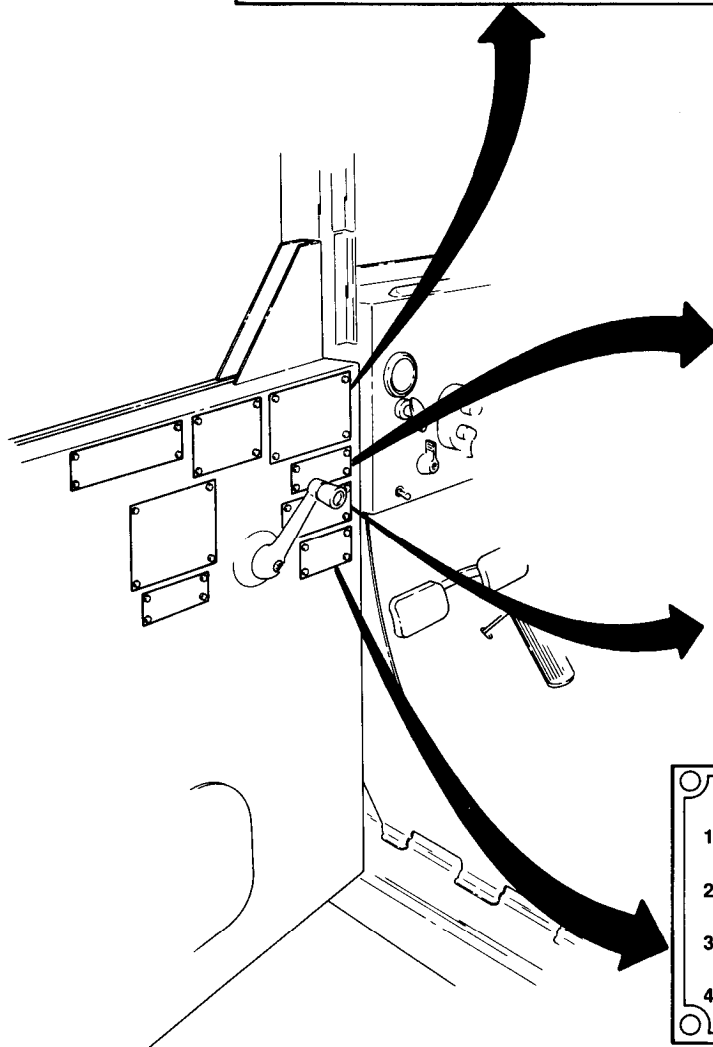

**CAUTION**

DO NOT OPERATE TRANSFER P.T.O. WITH TRANSMISSION IN 4TH OR 5TH GEAR.

**WARNING**

TO STOP WINCH WITH LOAD ON CABLE DISENGAGE VEHICLE CLUTCH AND MOVE THE POWER DIVIDER CONTROL LEVER TO NEUTRAL POSITION.  
DO NOT DISENGAGE THE REAR WINCH.

**CAUTION**

1. LOWER OUTRIGGERS PRIOR TO BORING OR WINCH OPERATIONS.
2. RAISE OUTRIGGERS PRIOR TO MOVING VEHICLE.
3. REMOVE AND STOW OUTRIGGER FEET BEFORE MOVING VEHICLE.
4. LOCK OUTRIGGERS DURING TRAVEL.

1-13. LOCATION AND CONTENTS OF WARNING, CAUTION, AND DATA PLATES (Contd)

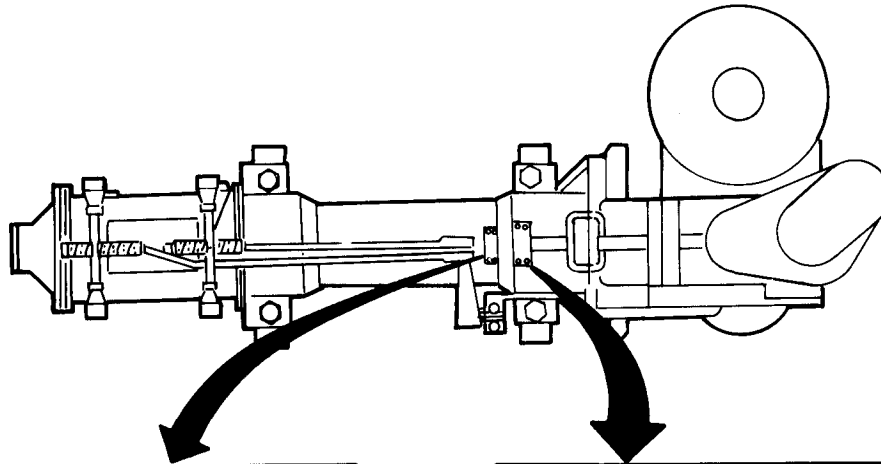

**WARNING**  
 LOCK BORING MACHINE LEVERS  
 IN BACK POSITION WITH LOCKING  
 LATCH BEFORE LEAVING CONTROLS.

**CAUTION**

1. LOWER OUTRIGGERS PRIOR TO BORING OR WINCH OPERATIONS.
2. RAISE OUTRIGGERS PRIOR TO MOVING VEHICLE.
3. REMOVE AND STOW OUTRIGGER FEET BEFORE MOVING VEHICLE.
4. LOCK OUTRIGGERS DURING TRAVEL.

**BORING MACHINE LEVELING PROCEDURE**

1. SET POWER LEVELER HANDLE TO OBTAIN THE RACK BAR MOVEMENT INDICATED BELOW.
2. TO ACTIVATE LEVELING:  
 LEFT BORING MACHINE LEVER—NEUTRAL  
 RIGHT BORING MACHINE LEVER—FORWARD

**VEHICLE TRANSMISSION**

\_\_\_\_\_  
 1ST REVERSE

\_\_\_\_\_  
 1ST REVERSE

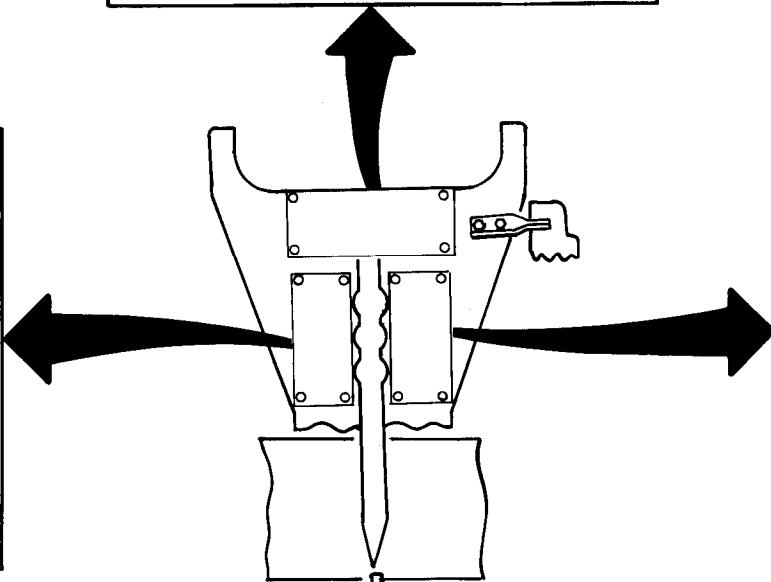

**DIRECTION OF RACK BAR MOVEMENT**

\_\_\_\_\_  
 RIGHT  
 LEFT

\_\_\_\_\_  
 NEUTRAL

\_\_\_\_\_  
 RAISE  
 LOWER

1-13. LOCATION AND CONTENTS OF WARNING, CAUTION, AND DATA PLATES (Contd)

**CAUTION**  
DO NOT EXCEED THE PULLING CAPACITY SPECIFIED

A	PULLING CAP.
VERT	5,000 LBS.
3'	4,100 LBS.
4'	3,000 LBS.
5'	2,500 LBS.
6'	2,100 LBS.
8'	1,600 LBS.
10'	1,300 LBS.

PULLING CAPACITY 5,000 LBS. IN ANY DIRECTION AT ALL ANGLES WHEN SNATCH SHEAVE IS USED.

**CAUTION**

- DO NOT STRIKE BUMPER SPRING AGAINST BOTTOM OF BORING HEAD.
- DO NOT LOAD AUGER ABOVE BUMPER SPRING.
- DO NOT RUN THE AUGER RACK BAR BELOW THE BOTTOM SIGHTING HOLE IN THE DERRICK TUBE.
- PERSONNEL SHOULD AVOID AUGER DURING OPERATION.

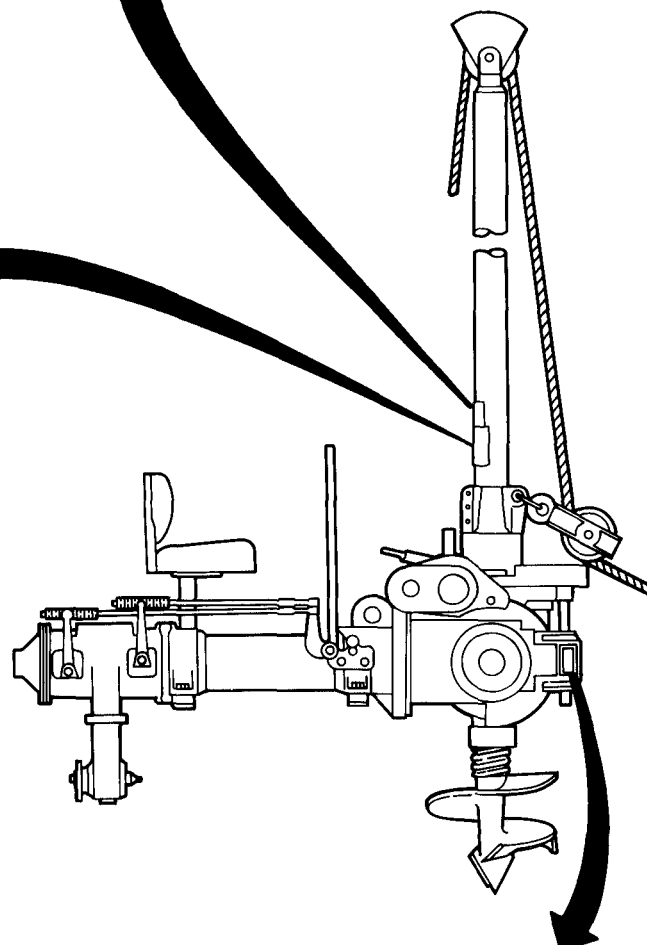

**WARNING**  
EAR PROTECTION REQUIRED DURING OPERATION OF AUGER



1-13. LOCATION AND CONTENTS OF WARNING, CAUTION, AND DATA PLATES (Contd)

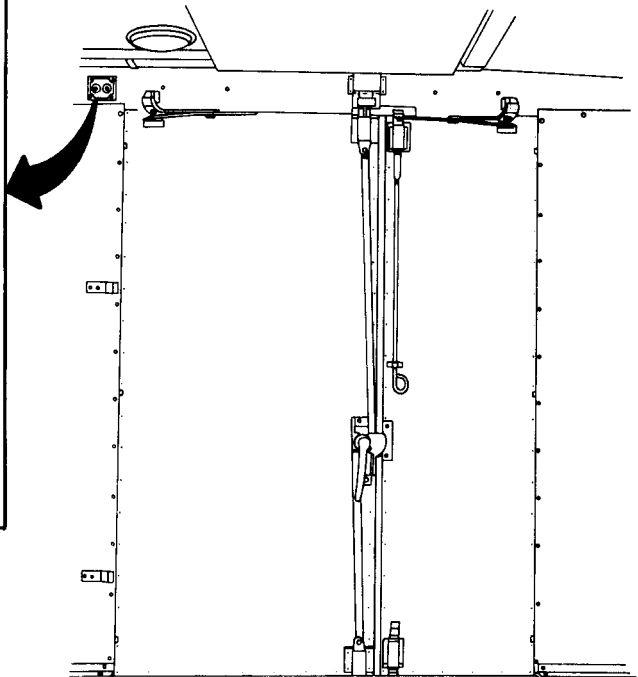
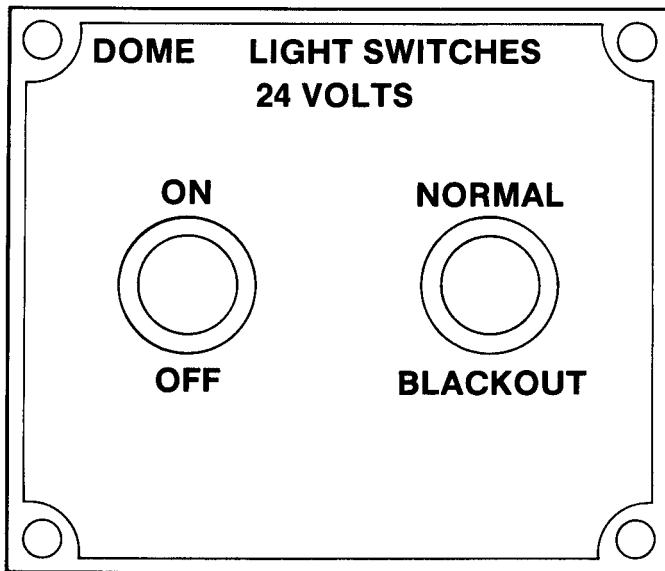
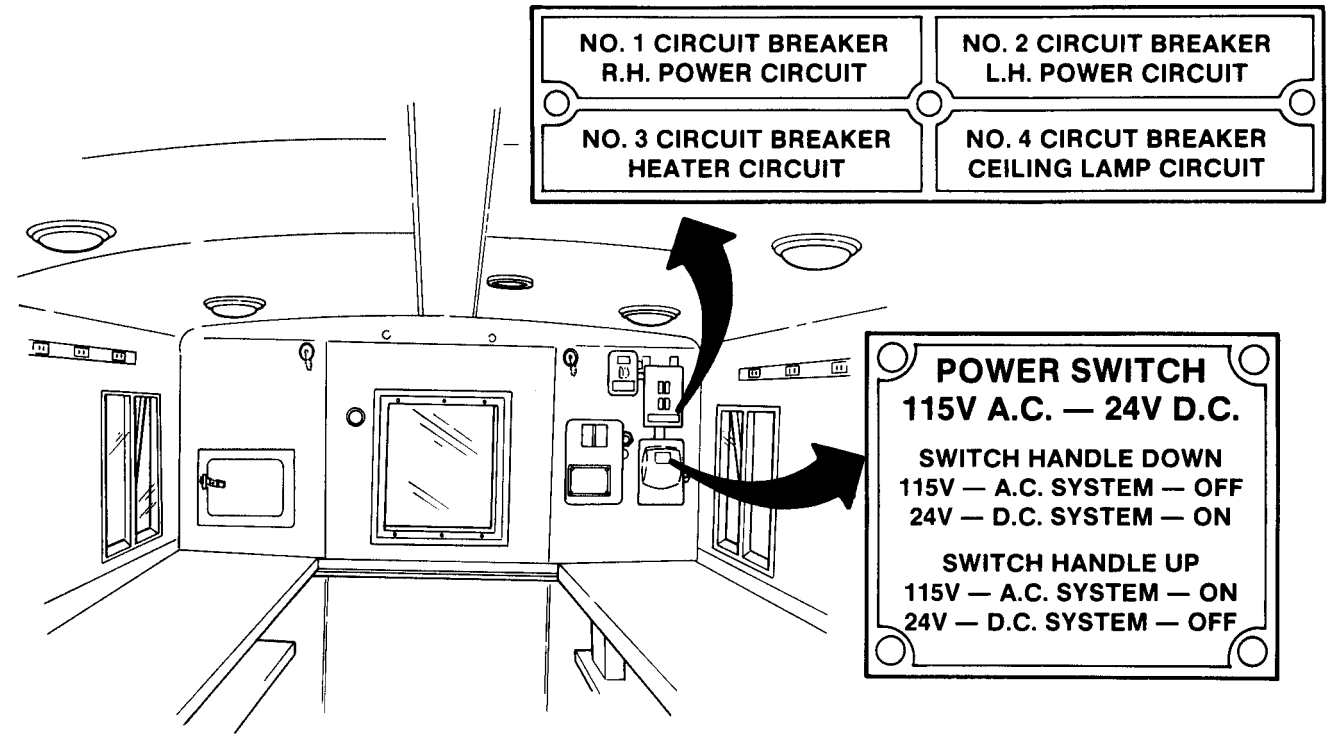

1-13. LOCATION AND CONTENTS OF WARNING, CAUTION, AND DATA PLATES (Contd)

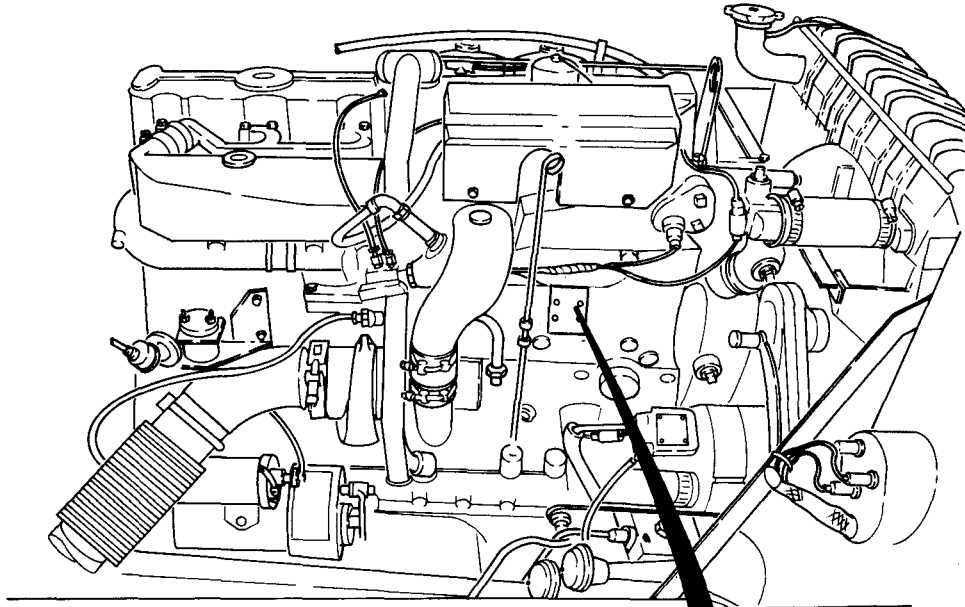

<b>ENGINE EXHAUST EMISSION CONTROL INFORMATION</b>	
<b>MULTIFUEL</b>	
<input type="radio"/> MODEL LDT465	<input type="text"/> DATE OF ENGINE MFG MO & YR <input type="text"/> <input type="radio"/>
<b>ENGINE SPECIFICATIONS</b>	
ADVERTISED H.P. <input type="text"/> AT <input type="text"/> R.P.M.	
FUEL RATE AT ADVERTISED H.P. <input type="text"/> MM <sup>3</sup> /STROKE	
VALVE LASH INT. <input type="text"/> IN. EXH. <input type="text"/> IN.	
INJECTION TIMING <input type="text"/>	
THIS ENGINE CONFORMS TO U.S. ENVIRONMENTAL PROTECTION AGENCY REGULATIONS APPLICABLE TO <input type="text"/> MODEL YEAR HEAVY-DUTY DIESEL ENGINES	
<b>CONTRACT NO.</b>	
<input type="radio"/> <input type="text"/>	<input type="radio"/> <input type="text"/>
<b>PART NO. SERIAL NO.</b>	
<input type="text"/>	<input type="text"/>
<b>M.A.N. LICENSE</b>	<b>ACCEPTED</b>

**1-14. DIFFERENCES BETWEEN MODELS**

*Table 1-1. Differences Between Models.*

EQUIPMENT/FUNCTION	M35A2	M35A2C	M36A2	M49A2C	M50A2	M50A3	M109A3	M185A3	M275A2	M342A2	M756A2	M764
Cargo Transport	X	X	X							X		
Personnel Transport	X	X								X	X	
Fuel Servicing				X								
Water Servicing					X	X						
Shop Van							X					
Instrument Repair Shop								X				
Fifth Wheel Operations									X			
Dump Operations										X		
Pipeline Construction											X	
Earth Boring												X
Cab Protector										X	X	X
Floodlights											X	
Front Winch (10,000 lb capacity)	X	X	X	X	X	X	X	X	X	X	X	X
Rear Winch (20,000 lb capacity)											X	
Rear Winch (14,000 lb capacity)												X
Cargo:												
Permanent Sides	X		X				X	X		X		X
Removable Sides		X	X								X	
Tires/Tubes (9:00 x 20) 8 ply	X	X	X	X	X	X	X	X	X	X	X	X

**1-15. EQUIPMENT DATA**

Equipment performance data for the M44A2 series vehicles is listed in table 1-2. This information includes only that data applicable to unit maintenance. Information not covered can be found in TM 9-2320-361-10 or LO 9-2320-209-12-1.

*Table 1-2. Equipment Data.*

**NOTE**

Standard and metric measurements will be used in this table. A list of their abbreviations is provided below.

**TABULATED DATA ABBREVIATIONS**

<b>MEASUREMENT</b>	<b>ABBREVIATION</b>	<b>MEASUREMENT</b>	<b>ABBREVIATION</b>
Ampere . . . . .	A	KiloWatt . . . . .	kW
Ampere Per Hour . . . . .	A/h	Liters . . . . .	L
Celsius . . . . .	C	Maximum . . . . .	max.
Centimeter . . . . .	cm	Miles Per Hour . . . . .	mph
Cubic Feet Per Minute . . . . .	cfm	Miles Per Gallon . . . . .	mpg
Cubic Meters Per Minute . . . . .	cm <sup>3</sup> /m	Millimeter . . . . .	mm
Fahrenheit . . . . .	F	Minimum . . . . .	min
Gallons . . . . .	gal.	Newton Meter . . . . .	N·m
Horsepower . . . . .	hp	Pint . . . . .	pt
Inch . . . . .	in.	Pound . . . . .	lb
Kilograms . . . . .	kg	Pound-Feet . . . . .	lb-ft
Kilometers Per Hour . . . . .	km/h	Pound Per Square Inch . . . . .	psi
Kilometers Per Liter . . . . .	km/L	Quart . . . . .	qt
KiloPascal . . . . .	kPa	Revolutions Per Minute . . . . .	rpm

	<b>STANDARD</b>	<b>METRIC</b>
<b>1. MAXIMUM PAYLOAD PER VEHICLE</b>		
M35A2, M35A2C, M36A2, M109A3, M185A3, M342A2, M756A2 . . . . .	5,000 lb	2,270 kg
M49A2C . . . . .	1,200 gal.	4,542 L
M50A2 . . . . .	1,000 gal.	3,785 L
M50A3 . . . . .	1,000 gal.	3,785 L
M275A2 . . . . .	7,000 lb	3,178 kg
M764 . . . . .	500 lb	227 kg
<b>2. CAPACITIES</b>		
Cooling system . . . . .	32 qt	30.3 L
Engine:		
Crankcase Only . . . . .	20 qt	18.9 L
Crankcase and Filter . . . . .	22qt	20.8 L
Differential (front or rear) . . . . .	6 qt each	5.7 L
Fuel Tank (all vehicles) . . . . .	50 gal.	189.3 L

Table 1-2. Equipment Data (Contd).

	STANDARD	METRIC
Transmission:		
(without PTO) . . . . .	4.25 qt	4.0 L
(with PTO) . . . . .	5.25 qt	4.97 L
Transfer Case (with or without PTO) . . . . .	7 qt	6.6 L
Windshield Washer Reservoir. . . . .	3 qt	2.8 L
Dump Body Hydraulic Oil Reservoir . . . . .	18 qt	17 L
Front Winch:		
Housing, Clutch End . . . . .	1 pt	0.47 L
Worm Gear Housing . . . . .	1.50 pt	0.71 L
Rear Winch (M756A2 only):		
Housing, Clutch End . . . . .	1.75 pt	0.83 L
Worm Gear Housing . . . . .	2.6 pt	1.2 L
Rear Winch (M764 only):		
Worm Gear Housing . . . . .	7 pt	3.3 L
Speed Reducer . . . . .	1.75 pt	.83 L
Power Divider . . . . .	3.5 qt	3.3 L
Earth Boring Machine and Outriggers (M764):		
Boring Case . . . . .	10 qt	9.5 L
Intermediate Gearcase . . . . .	10 pt	4.7 L
Clutch and Brake . . . . .	5 qt	4.7 L
Hydraulic Outriggers . . . . .	8 qt	7.6 L

3. ENGINE

Manufacturer . . . . .	Hercules Engines, Inc.	
Model . . . . .	LD-465-1, LD-465-1C	
Type . . . . .	Liquid-Cooled, Multifuel, Six Cylinders, In-Line	
Model . . . . .	LDT-465-1C, LDT-465-1D	
Type . . . . .	Turbocharged, Liquid-Cooled, Multifuel, Six Cylinders, In-Line	
Weight . . . . .	1,650 lb	749 kg
Idle Speed:		
Early Models (LD-465-1, LD-465-1C)		
(engine idle speed stamped on fuel pump ID plate) . . . . .	650-700 rpm	
Late Models (LDT-465-1C, LDT-465-1D)		
(engine idle speed stamped on fuel pump ID plate) . . . . .	800-850 rpm	
Operating Speed:		
Full Load (governed) . . . . .	1200-2650 rpm	
No Load (governed) . . . . .	1200-2900 rpm	
Brake Horsepower:		
Gross (fan belt removed; air compressor turning but unloaded) . . . . .		
	130 hp (min) @ 2600 rpm	96.98 kW @ 2600 rpm
Net (fan belt installed; alternator and air compressor turning but unloaded) . . . . .		
	118 hp @ 2600 rpm	88.0 kW @ 2600 rpm
Torque:		
Gross . . . . .	305 lb-ft @ 1500 rpm	414 N·m @ 1500 rpm
Net . . . . .	297 lb-ft @ 1500 rpm	403 N·m @ 1500 rpm

Table 1-2. Equipment Data (Contd).

	STANDARD	METRIC
Oil Pressure:		
Idle (with OE/HDO @ 200°F) . . . . .	10 psi min	68.95 kPa
Full Load @ 2600 rpm . . . . .	40 psi min	275.8 kPa
	75 psi max	517.13 kPa
Air Flow @ 2600 rpm . . . . .	405 cfm	11.34 cm/m
Compression Ratio . . . . .	22:1	
Firing Order . . . . .	1, 5, 3, 6, 2, 4	
Fuel Consumption (approx.) . . . . .	5-6 mpg	2.13-2.55 km/L
Manifold Heater (for cold weather starting):		
Type . . . . .	Flame Type, Spark Ignition	
Spark Ignition Gap . . . . .	0.088-0.093 in.	2.23-2.36 mm
Fuel Pump . . . . .	Electric	
Fuel . . . . .	(Multifuel) Same as Engine	
 4. FUEL SYSTEM		
Fuel Pump Locations:		
Electrical . . . . .	In Tank	
Mechanical . . . . .	On Fuel Injection	
Mechanical . . . . .	Fuel Injection Pump	
Fuel Filter (primary, secondary, final):		
Manufacturer . . . . .	Bendix or Purolator	
Air Cleaner:		
Type . . . . .	Dry Element	
Air Flow . . . . .	.410 cfm max	11 cm/m
 5. COOLING SYSTEM		
Radiator Filler Cap Pressure. . . . .	6.5 to 8 psi	44.8 to 55.2 kPa
Thermostat:		
Starts to Open . . . . .	180°F	82°C
Fully Open . . . . .	200°F	93°C
Radiator . . . . .	Vertical Flow Type	
 6. ELECTRICAL SYSTEM		
Batteries:		
Model . . . . .	6TN	
Voltage . . . . .	12 Volts	
Plates Per Cell . . . . .	23	
Number of Batteries . . . . .	2	
Temp When Fully Charged . . . . .	80°F	26.6°C
Rating . . . . .	100 A/h	
Alternator		
Manufacturer . . . . .	Prestolite Co.	
Model . . . . .	AMA 5102UT	
Voltage Output . . . . .	28 Vmax	
Current Output . . . . .	60 A max	
Voltage Regulator . . . . .	Mounted Internally	
Starter:		
Voltage . . . . .	24 Volts	
Specification . . . . .	MS53011-2	
Mounting Plate to Pinion Housing Rotation . . . . .	285°	
Capacity (peak). . . . .	9.5 hp	7.1 kW

Table 1-2. Equipment Data (Contd).

STANDARD

METRIC

7. TRANSMISSION

Manufacturer . . . . . Spicer Div-Dana Corp.  
 Model . . . . . 3053A  
 Type . . . . . Syncromesh  
 Speeds . . . . . 5 Forward, 1 Reverse  
 Gear Ratios:  
     First Speed (No Synchronizing Gear) . . . . . 5.02 to 1  
     Second Speed . . . . . 2.78 to 1  
     Third Speed . . . . . 1.62 to 1  
     Fourth Speed . . . . . 1.00 to 1.00  
     Fifth Speed (Override) . . . . . 0.79 to 1  
     Reverse (No Synchronizing Gear) . . . . . 4.90 to 1  
 Oil Type . . . . . GO 80/90

8. TRANSMISSION POWER TAKEOFF (ALL EXCEPT M342A2)

Manufacturer . . . . . Spicer Div-Dana Corp.  
 Model . . . . . WN-7-28  
 Type . . . . . Heavy-Duty  
 Speeds . . . . . 2 Forward, 1 Reverse  
 Input Drive . . . . . Transmission  
 Horsepower Delivered:  
     100 rpm . . . . . 2.7  
     500 rpm . . . . . 13  
     1000 rpm . . . . . 27  
 Output Shaft (Front) . . . . . 1-1/4in. Dia.; 5/16in. Keyway  
 Use . . . . . Front Winch Drive  
 Location . . . . . left Side of Transmission  
 Oil Type . . . . . Lubricated from Transmission

9. TRANSMISSION POWER TAKEOFF (M342A2)

Manufacturer . . . . . Spicer Div-Dana Corp.  
 Model . . . . . WND-7-28  
 Type . . . . . Heavy-Duty  
 Speeds . . . . . 2 Forward, 1 Reverse  
 Input Drive . . . . . Transmission  
 Horsepower Delivered:  
     100 rpm . . . . . 2.7  
     500 rpm . . . . . 13  
     1000 rpm . . . . . 27  
 Output Shaft (Front) . . . . . 1-1/4 in., Dia.; 5/16 in. Keyway  
 Output Shaft (Rear) . . . . . 7/8in. Dia.; 5/16 in. Keyway  
 Use:  
     Output Shaft (Front) . . . . . Front Winch Drive  
     Output Shaft (Rear) . . . . . Dump Body Hydraulic Pump Drive  
 Location . . . . . Left Side of Transmission  
 Oil Type . . . . . Lubricated from Transmission

Table 1-2. Equipment Data (Contd).

	STANDARD	METRIC
<b>10. TRANSFER CASE</b>		
Manufacturer . . . . .	Rockwell Int.	
Model . . . . .	T-136-27	
Type . . . . .	Two-Speed Syncromesh	
Front Axle Engagement . . . . .	Air Actuated	
Transmission Driven Input Shaft to Output Shaft for Rear Axles:		
Drive Ratio:		
Low Range (High Load) . . . . .	1.980 to 1.000	
High Range (Low Load) . . . . .	1.010 to 1.000	
Transmission Driven Input Shaft to Front Output Shaft for Front Axle:		
Drive Ratio:		
Low Range (High Load) . . . . .	2.137 to 1.000	
High Range (Low Load) . . . . .	1.078 to 1.000	
Oil Type . . . . .	GO 80/90	
<b>11. TRANSFER CASE POWER TAKEOFF</b>		
Manufacturer . . . . .	Rockwell Int.	
Model . . . . .	P-136-C	
Speed . . . . .	One (Variable with Engine RPM and Transmission Gear Selection)	
Input Drive . . . . .	Transfer	
Output Shaft . . . . .	Tapered 1-1/2 in. to 1 in.	
Horsepower Delivered . . . . .	Same as Engine HP	
Location . . . . .	Top Rear of Transfer Case	
Use . . . . .	Rear Winch Drive, Fuel Tanker Pump, Water Tanker Pump, or Earth Auger	
<b>12. FRONT WINCH</b>		
Specification . . . . .	MS51352	
Manufacturer . . . . .	Spicer or Beekin	
Type . . . . .	PTO Shaft Driven	
Winch Capacity . . . . .	10,000 lb max	4,536 kg
Cable Capacity (1/2 in. dia. test load). . . . .	10,432 lb max	4,732 kg
Operating Capacity with 1/2 in. Dia. Cable 200 ft Long:		
Maximum line load at any time not to exceed . . . . .	6,100 lb	2,769 kg
Snatch block to be used when load is less than 100 ft from vehicle.		
Maximum snatch below load, unless stated on block, for any arrangement not to exceed . . . . .	10,000 lb	4,536 kg
Winch protected with aluminum shear pin.		



Table 1-2. Equipment Data (Contd)

	STANDARD	METRIC
<b>13. REAR WINCH (M756A2 ONLY)</b>		
Manufacturer . . . . .	Spicer or Beekin	
Type . . . . .	PTO Shaft Driven	
Winch Capacity . . . . .	20,000 lb max	9,072 kg
Cable Capacity (5/8 in. dia. test load) . . . . .	16,283 lb max	7,386 kg
Operating Capacity with 5/8 in. Dia. Cable 200 ft Long:		
Maximum line load at any time not to exceed . . . . .	9,500 lb	4,309 kg
Snatch block to be used when load is less than 100 ft from vehicle.		
Maximum snatch block load, unless stamped on block, for any arrangement not to exceed . . . . .	11,500 lb	5,216 kg
Winch protected with aluminum shear pin.		
<b>14. REAR WINCH (M764 ONLY)</b>		
Manufacturer . . . . .	Highway Trailer Ind.	
Model . . . . .	W-3780-D	
Type . . . . .	PTO Shaft Driven	
Winch Capacity . . . . .	14,000 lb max	6,350 kg
Cable Capacity (1/2 in. dia. test load) . . . . .	10,300 lb max	4,672 kg
Operating Capacity with 1/2 in. Dia. Cable, 700 ft Long:		
Maximum line load with derrick in vertical position only and without snatch block . . . . .	5,000 lb	2,268 kg
Maximum line load with top of derrick 10 ft from vertical position and without snatch block . . . . .	1,300 lb	590 kg
Maximum line load with derrick in any position and at all angles with snatch block . . . . .	5,000 lb	2,268 kg
Maximum line load with snatch block and without derrick . . . . .	8,000 lb	3,629 kg
Winch protected with aluminum shear pin.		
<b>15. TIRES</b>		
Tire Size . . . . .	9:00 x 20, 8 ply	

## Section III. PRINCIPLES OF OPERATION

**1-16. GENERAL**

This section explains how components of the 2-1/2-ton, M44A2 series vehicles work together. A functional description of these components and their related parts will be covered in the following paragraphs. Electrical wiring schematics shown are for reference only and are not to be used for troubleshooting. To find the operation of a specific system or component, see the principles of operation reference index below.

**1-17. PRINCIPLES OF OPERATION REFERENCE INDEX**

PARA. NO.	TITLE	PAGE NO.
1-18.	Control Systems Operation	1-38
1-19.	Power Systems Operation	1-46
1-20.	Electrical Systems Operation	1-56
1-21.	Compressed Air and Brake System Operation	1-60
1-22.	Special Purpose Bodies Systems Operation	1-64

## 1-18. CONTROL SYSTEMS OPERATION

The control systems include those controls and their related parts that are essential to the operation of the vehicle. These controls are common to all vehicles with the exception of transfer case power takeoff controls. Each part will be described as part of the following systems:

- a. **Starting System Operation (page 1-38).**
- b. **Manifold Heater System Operation (page 1-40).**
- c. **Accelerator Controls System Operation (page 1-41).**
- d. **Parking Brake System Operation (page 1-42).**
- e. **Steering System Operation (page 1-43).**
- f. **Clutch Control System Operation (page 1-44).**
- g. **Transfer Case Control System Operation (page 1-45).**

### a. Starting System Operation.

The starting system will start the engine in all types of weather and has built-in protection that prevents starter engagement once the engine has started. Major components of the starting system are:

- (A) ACCESSORY POWER SWITCH** - Activates all electrical circuits except arctic heaters.
- (B) STARTER SWITCH** - When pressed, provides battery power to starter relay.
- (C) FUEL PRESSURE SWITCH** - Prevents reengagement of starter motor once engine is running.
- (D) STARTER RELAY** - Transfers amperage through starter cables from battery to starter solenoid.
- (E) BATTERIES** - Provide 24-volt battery power to energize starter motor.
- (F) STARTER SOLENOID** - Actuates starter motor gear to crank vehicle engine.
- (G) STARTER MOTOR** - When energized, converts electrical energy to mechanical power as it engages the flywheel to crank engine.

1-18. CONTROL SYSTEMS OPERATION (Contd)

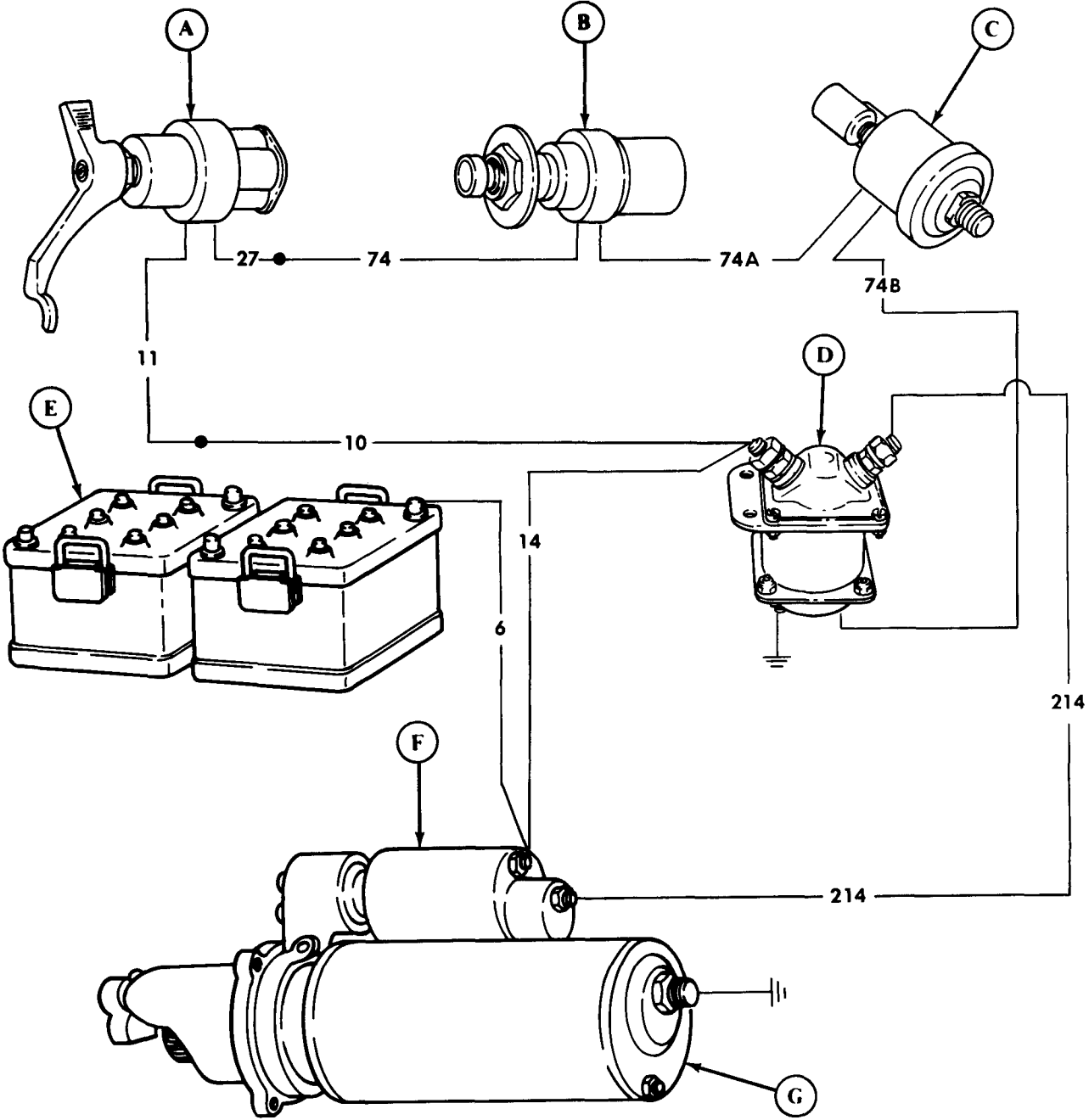

**1-18. CONTROL SYSTEMS OPERATION (Contd)**

**b. Manifold Heater System Operation.**

The manifold heater system warms air entering the intake manifold to allow engine to start in cold weather conditions. Major components of the manifold heater system are:

- (A) MANIFOLD HEATER SWITCH** - When pressed, the circuit to the heater fuel pump is activated. The spray nozzle valve is opened and the spark plug is energized by the ignition unit.
- (B) HEATER FUEL FILTER** - Cleans fuel before fuel enters fuel pump.
- (C) HEATER FUEL PUMP** - Supplies fuel to spray nozzle when activated.
- (D) HEATER SPRAY NOZZLE** - Distributes vaporized fuel into intake manifold.
- (E) HEATER IGNITION UNIT** - Energizes spark plug.
- (F) HEATER SPARK PLUG** - Ignites vaporized fuel distributed into intake manifold.

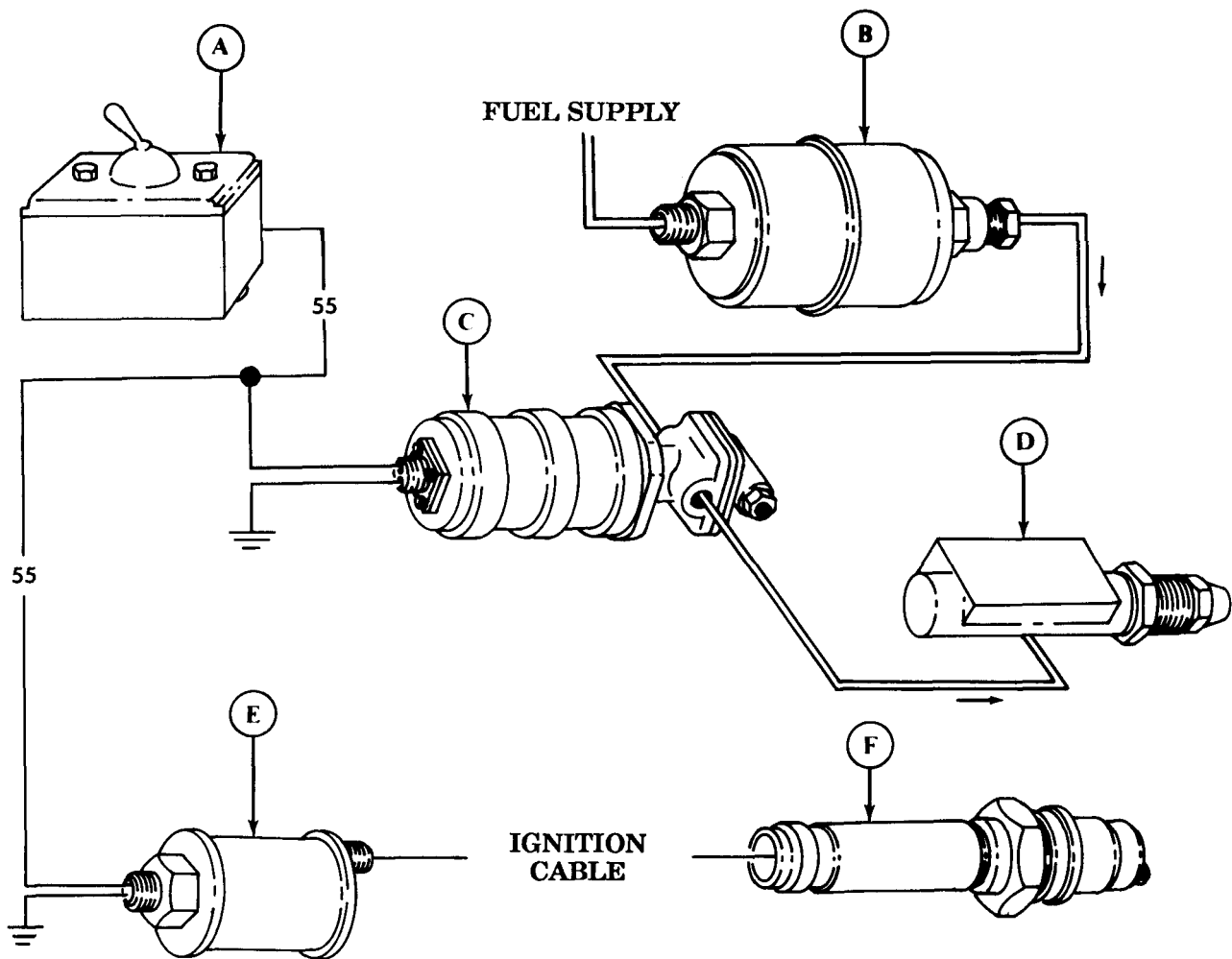

**1-18. CONTROL SYSTEMS OPERATION (Contd)**

**c. Accelerator Controls System Operation.**

The accelerator controls system permits the operator to control vehicle speed and engine power. Major components of the accelerator controls system are:

- (A) ENGINE STOP CONTROL** - Cuts off fuel supply to engine when pulled.
- (B) HAND THROTTLE CONTROL** - Sets engine speed at desired rpm without operator maintaining pressure on accelerator pedal.
- (C) ACCELERATOR PEDAL** - Controls engine speed.
- (D) ACCELERATOR LINKAGE** - Links accelerator pedal and throttle control to fuel pump.

1. Injection Pump Lever
2. Accelerator Rod
3. Return Spring
4. Pivot Lever

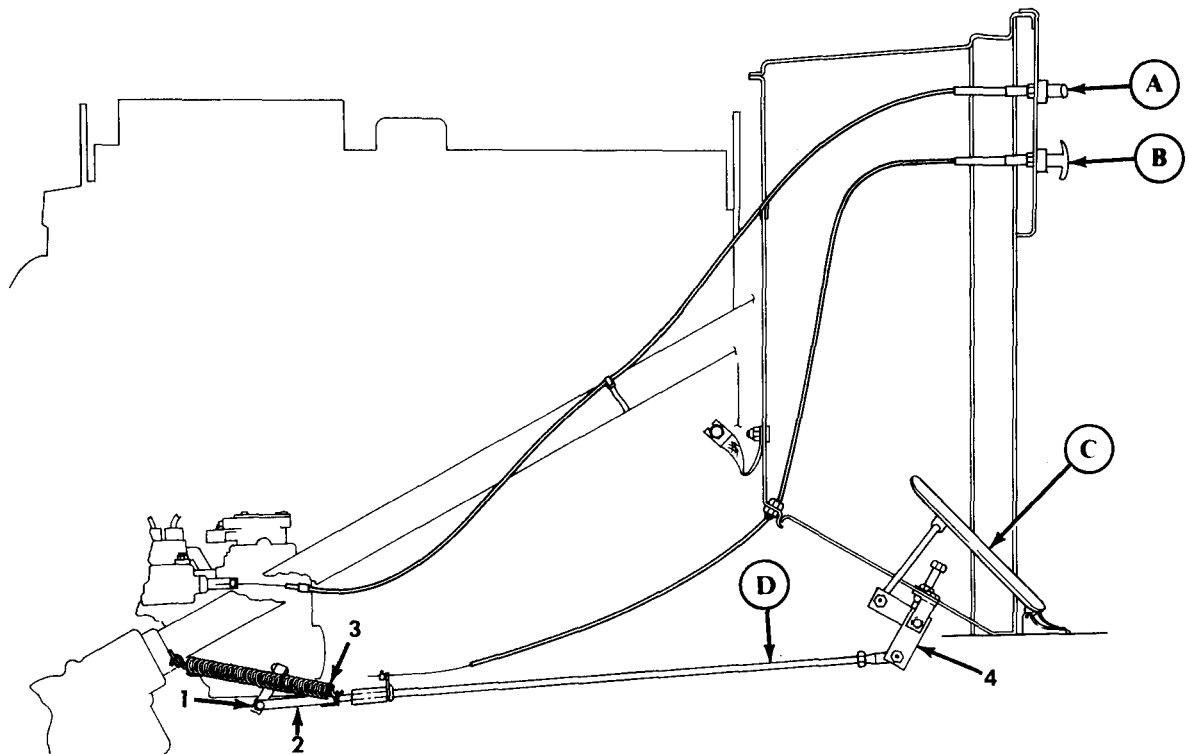
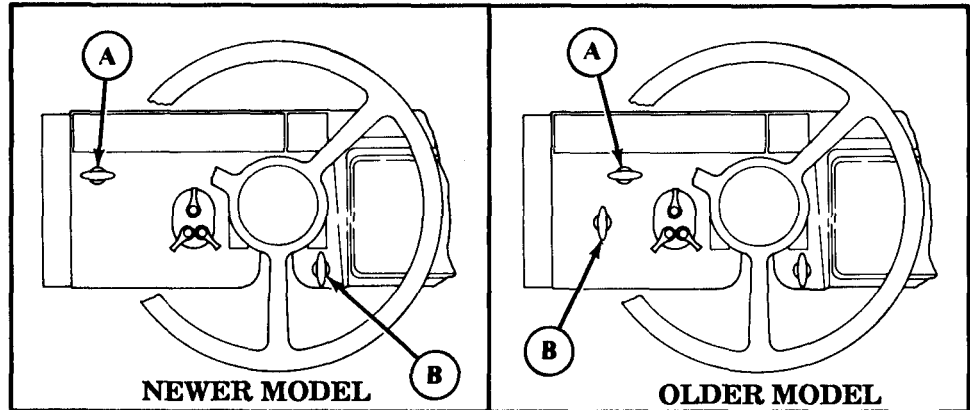

1-18. CONTROL SYSTEMS OPERATION (Contd)

**d. Parking Brake System Operation.**

The parking brake system is a manually-operated system that provides a means of keeping the vehicle motionless when it is stopped. Major components of the parking brake system are:

- (A) PARKING BRAKE CONTROL LEVER** - Applies parking brake when pulled to raised position. When lowered, parking brake is released.
- (B) ADJUSTING KNOB** - Permits operator to make minor tension adjustment in parking brake cable.
- (C) PARKING BRAKE CABLE** - Links parking brake lever to actuating lever.
- (D) BRAKEDRUM** - Provides surface for brakeshoes to press against when parking brake is applied.
- (E) ACTUATING LEVER** - Forces inner and outer brakeshoes against brakedrum when parking brake control lever is raised.
- (F) PARKING BRAKE ADJUSTING SCREW** - Used to ensure full contact of brakeshoes with brakedrum.
- (G) BRAKESHOES** - Apply friction to brakedrum when parking brake control lever is raised.
- (H) ECCENTRIC PIN** - Equalizes distance between brakeshoes and brakedrum.

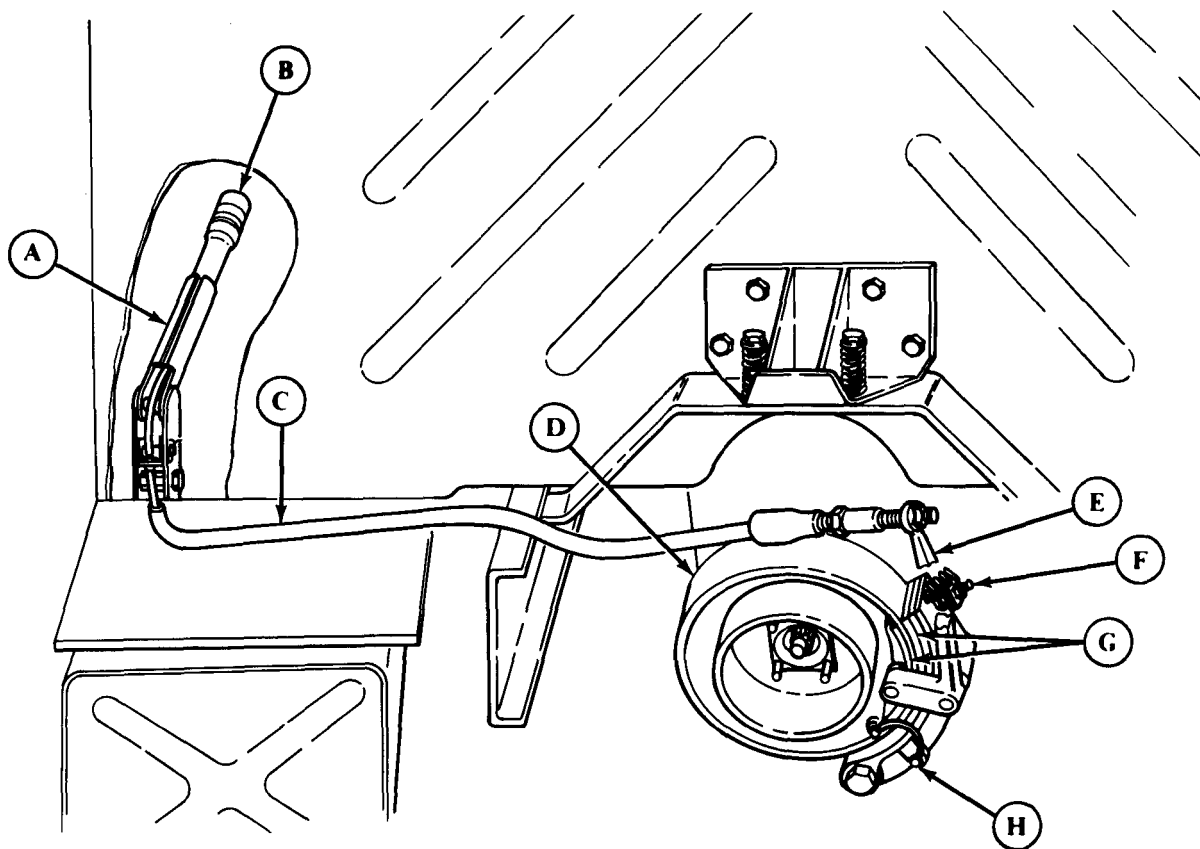

## 1-18. CONTROL SYSTEMS OPERATION (Contd)

### e. Steering System Operation.

Major components of the steering system are:

- (A) **STEERING COLUMN** - Supports steering shaft through instrument panel and firewall to steering gear.
- (B) **STEERING WHEEL** - Used by operator to control direction of vehicle travel.
- (C) **STEERING ARM** - Connects drag link to steering knuckle.
- (D) **TIE ROD** - Connects steering knuckles so both front wheels will pivot when steering wheel is turned.
- (E) **DRAG LINK** - Transmits movement from pitman arm to the steering arm.
- (F) **STEERING KNUCKLE** - Serves as a pivot point and link for the front wheel from the tie rod.
- (G) **PITMAN ARM** - Transmits steering torque from steering gear to drag link.
- (H) **STEERING GEAR** - Transmits mechanical power from the steering wheel to the pitman arm.

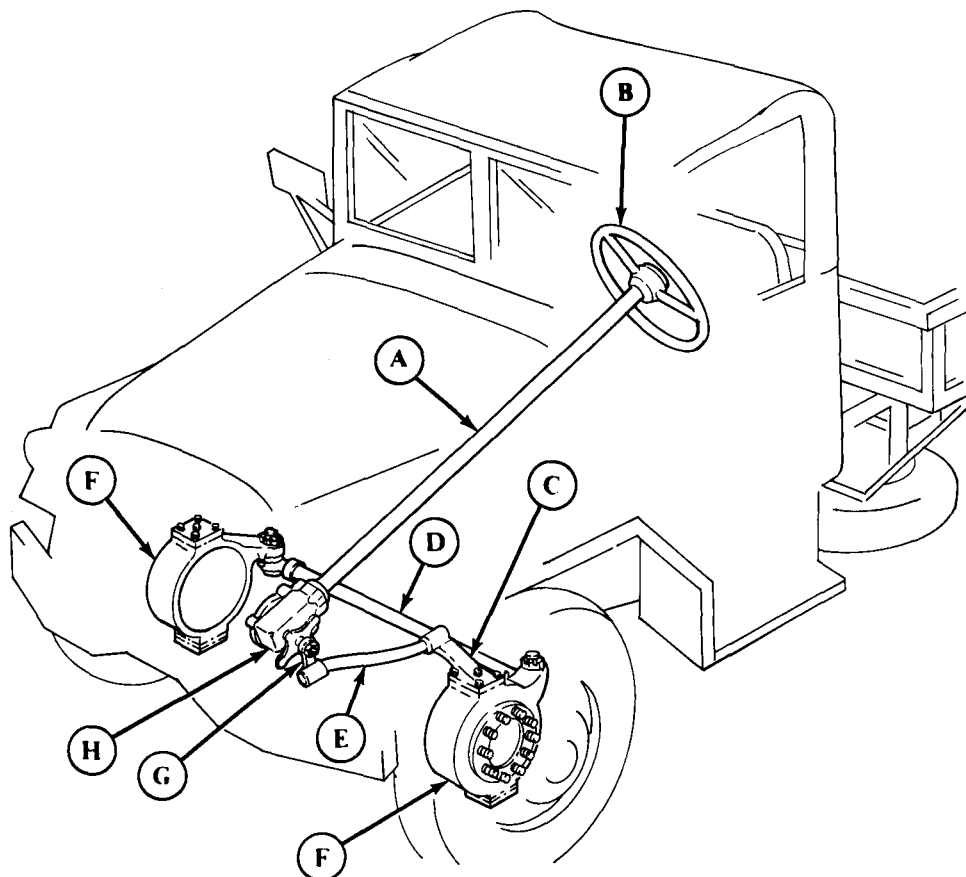



**1-18. CONTROL SYSTEMS OPERATION (Contd)**

**f. Clutch Control System Operation.**

The clutch control system permits engagement or disengagement of transmission and transmission power takeoff (PTO). Major components of the clutch control system are:

- (A) CLUTCH PEDAL** - When pressed down, it disengages transmission from engine. When released, engine and transmission are engaged.
- (B) REMOTE CONTROL LEVER** - Transmits movement of clutch rod to actuate clutch.
- (C) CLUTCH ROD** - Transmits movement from clutch pivot assembly to remote control lever and shaft, and is used to adjust clutch pedal free travel.
- (D) CLUTCH PIVOT ASSEMBLY** - Transfers torque from clutch lever to clutch rod.
- (E) CLUTCH LEVER** - Transmits movement from clutch pedal to clutch pivot assembly.

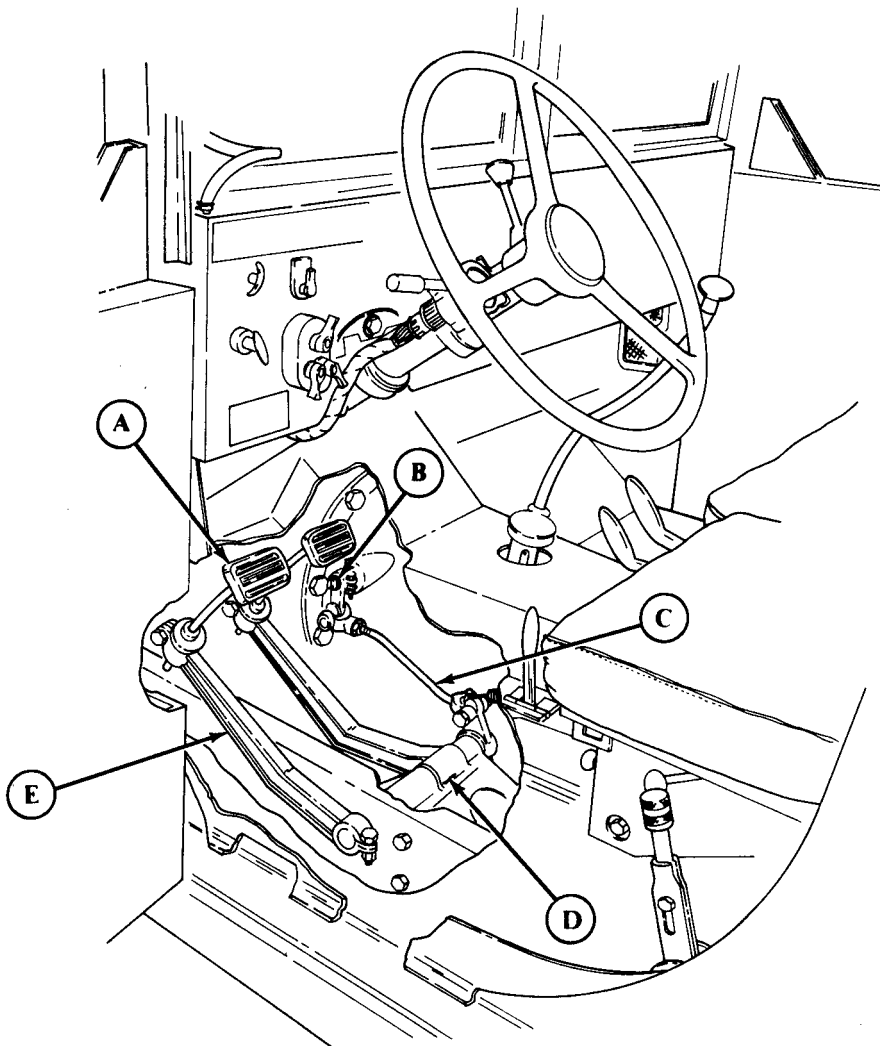

## 1-18. CONTROL SYSTEMS OPERATION (Contd)

### g. Transfer Case Control System Operation.

The transfer case control system converts four-wheel driving power into six-wheel driving power and provides source of power to operate auxiliary equipment through a power takeoff (PTO). Major components of transfer case control system are:

- (A) TRANSFER CASE SHIFT LEVER** - Is pulled up to HIGH for light load operations or pushed down to LOW for heavy load operations.
- (B) TRANSFER CASE SHIFT LEVER LINK** - Transmits movement of transfer case shift lever to shift shaft.
- (C) TRANSFER CASE LOCKOUT ROD** - Actuates and adjusts the movement of transfer case lockout.
- (D) TRANSFER CASE PTO CONTROL LEVER LINK** - Transmits movement of transfer case PTO control lever assembly to transfer case PTO lever.
- (E) TRANSFER CASE PTO CONTROL LEVER ASSEMBLY** - Manual control for engaging power takeoff.
- (F) TRANSFER CASE LOCKOUT** - Locks transfer case in NEUTRAL position to prevent vehicle movement when transfer case PTO is engaged.

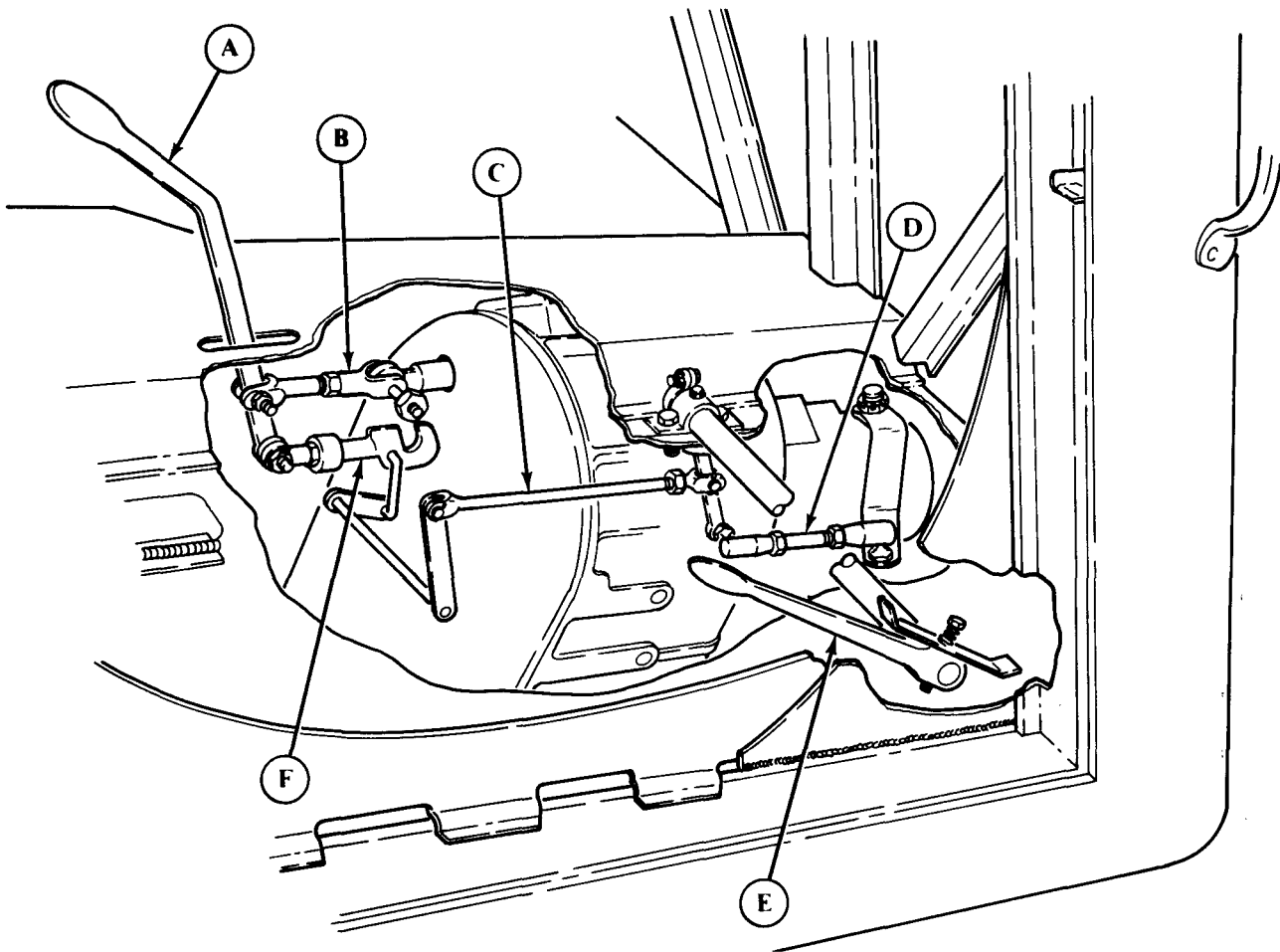

## 1-19. POWER SYSTEMS OPERATION

The power system includes those components that give all vehicles covered in this manual the power to move. Each of these components will be described as part of the following subsystems:

- a. **Powertrain System Operation (page 1-46).**
- b. **Engine Oil System Operation (page 1-48).**
- c. **Fuel System Operation (page 1-50).**
- d. **Air Intake System Operation (page 1-52).**
- e. **Exhaust System Operation (page 1-53).**
- f. **Cooling System Operation (page 1-54).**

### a. Powertrain System Operation.

The powertrain system is the same on all models covered in this manual with the exception of the long wheel base models which have an additional propeller shaft and center bearing. The powertrain transmits engine power throughout the vehicle to put it in motion. Major components of the powertrain are:

- (A) ENGINE** - Provides mechanical power for powertrain component operation.
- (B) TRANSMISSION** - Transfers engine power to meet different speeds and power requirements.
- (C) TRANSFER CASE** - Distributes power to front and rear axles.
- (D) UNIVERSAL JOINTS** - Permit power to be transmitted at slight angles between transmission and transfer case and between transfer case and differentials.
- (E) DIFFERENTIALS** - Distribute power to left and right axle shafts independently.
- (F) AXLES** - Transmit power from differentials to wheels.
- (G) PROPELLER SHAFTS** - Drive shafts that transmit power from the transmission to the transfer case, to the differentials.
  - 1. Front differential to transfer case propeller shaft
  - 2. Transmission to transfer case propeller shaft
  - 3. Transfer case to forward-rear differential propeller shaft
  - 4. Forward-rear differential to rear-rear differential propeller shaft

1-19. POWER SYSTEMS OPERATION (Contd)

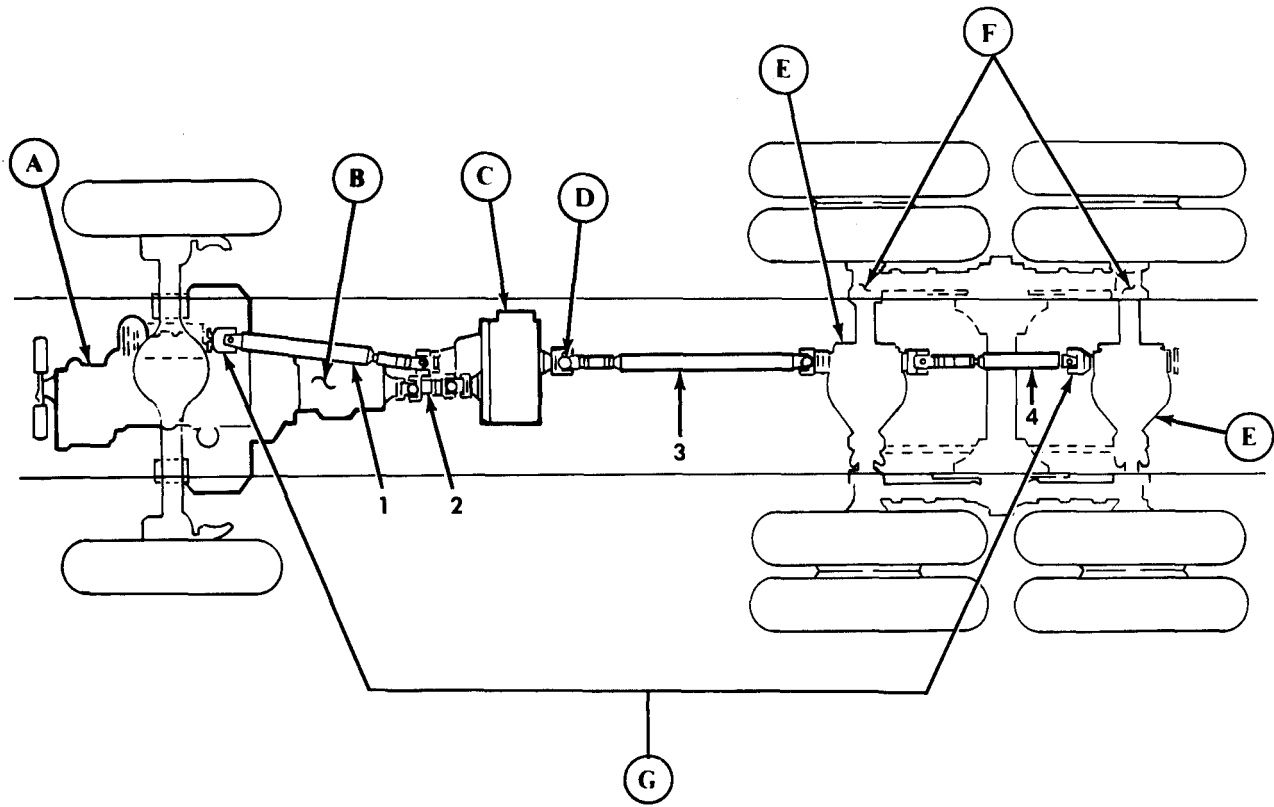

**1-19. POWER SYSTEMS OPERATION (Contd)**

**b. Engine Oil System Operation.**

The engine oil system provides lubricating oil for internal engine parts. Major components of the engine oil system are:

- (A) CRANKCASE BREATHER** - Vents engine crankcase.
- (B) OIL FILLER CAP** - Covers engine oil fill opening.
- (C) OIL DIPSTICK** - Indicates engine oil level.
- (D) OIL PRESSURE TRANSMITTER** - Sends an electrical signal indicating engine oil pressure to the oil pressure gage on instrument panel.
- (E) OIL FILTERS** - Filters oil of dirt and other foreign material to help ensure flow of uncontaminated oil to engine.
- (F) ENGINE OIL COOLER** - Removes excess heat from engine oil as coolant circulates through internal tubes of oil cooler.
- (G) ENGINE OIL PAN** - Reservoir for engine oil.
- (H) ENGINE OIL PAN DRAINPLUG** - When removed, allows lubricating oil to be drained from engine.

1-19. POWER SYSTEMS OPERATION (Contd)

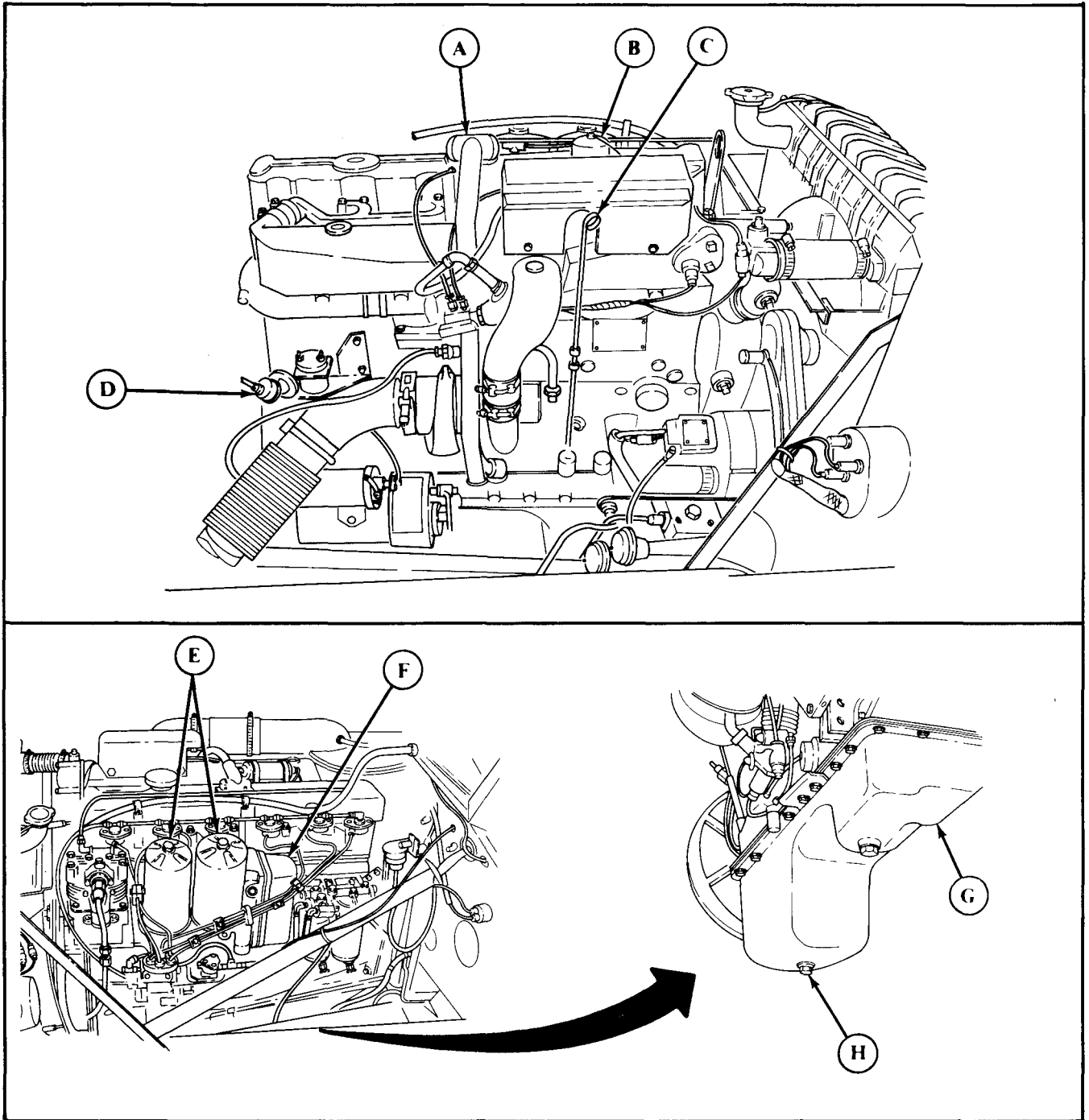

**1-19. POWER SYSTEMS OPERATION (Contd)****c. Fuel System Operation.**

The fuel system stores, cleans, and supplies fuel to the fuel injectors where it is mixed with air for combustion in engine cylinders. Major components of the fuel system are:

- (A) PRIMARY FUEL FILTER** - First filter to remove water and dirt from fuel.
- (B) FUEL SUPPLY LINE** - Directs fuel from fuel pump in fuel tank to primary fuel filter, to fuel transfer pump, to secondary and final fuel filters, to fuel injector pump, and then to fuel injectors.
- (C) FUEL TANK FILLER CAP** - Covers fuel fill opening.
- (D) FUEL LEVEL SENDING UNIT** - Detects fuel level in fuel tank and sends an electrical signal to fuel gage on instrument panel.
- (E) FUEL PUMP** - Draws fuel from fuel tank and pumps it through fuel supply line.
- (F) FUEL TANK** - Stores fuel for vehicle use.
- (G) FUEL RETURN LINE** - Directs unused fuel back to fuel tank.
- (H) VENT LINE** - Allows clean air to enter fuel tank as fuel supply is used up.
- (I) FUEL INJECTORS** - Spray a fine mist of fuel into combustion chambers.
- (J) FINAL FUEL FILTER** - Removes additional dirt from fuel.
- (K) SECONDARY FUEL FILTER** - Removes additional dirt from fuel.
- (L) FUEL TRANSFER PUMP** - Forces flow of fuel through secondary and final fuel filters to the fuel injector pump.
- (M) FUEL INJECTOR PUMP** - Furnishes pressurized fuel to the fuel injectors.

1-19. POWER SYSTEMS OPERATION (Contd)

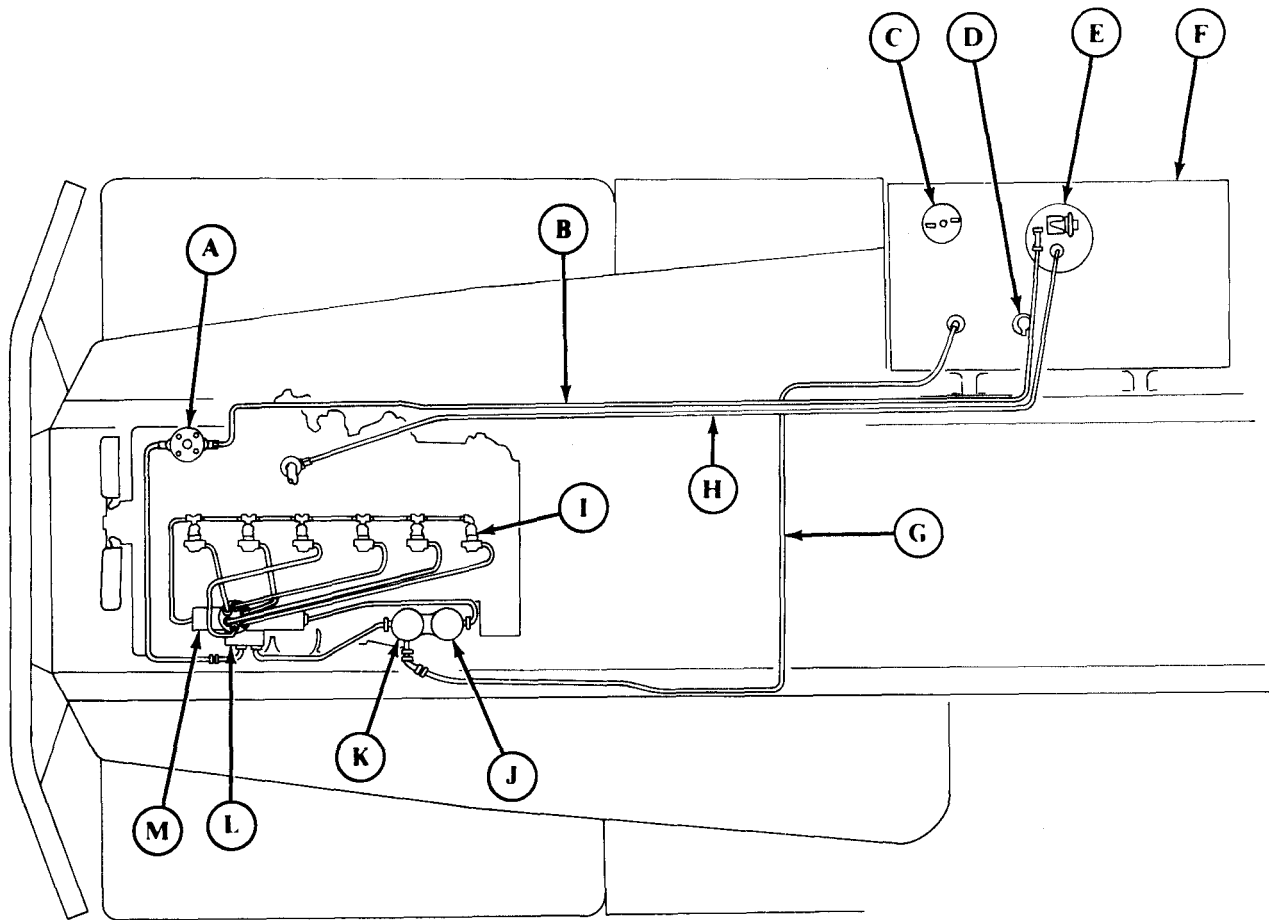



**1-19. POWER SYSTEMS OPERATION (Contd)**

**d. Air Intake System Operation.**

The air intake system cleans air going to the combustion chambers where it mixes with fuel from the injectors to provide power for the engine. Major components of the air intake system are:

- (A) AIR CLEANER** - Directs outside air through filter element.
- (B) FILTER ELEMENT** - Removes dirt and dust from the air.
- (C) AIR CLEANER OUTLET** - Directs air from air cleaner to turbocharger.
- (D) AIR CLEANER INDICATOR** - Shows red when filter element needs servicing.
- (E) AIR CLEANER HOOD** - Prevents rain and large objects from entering air intake system.

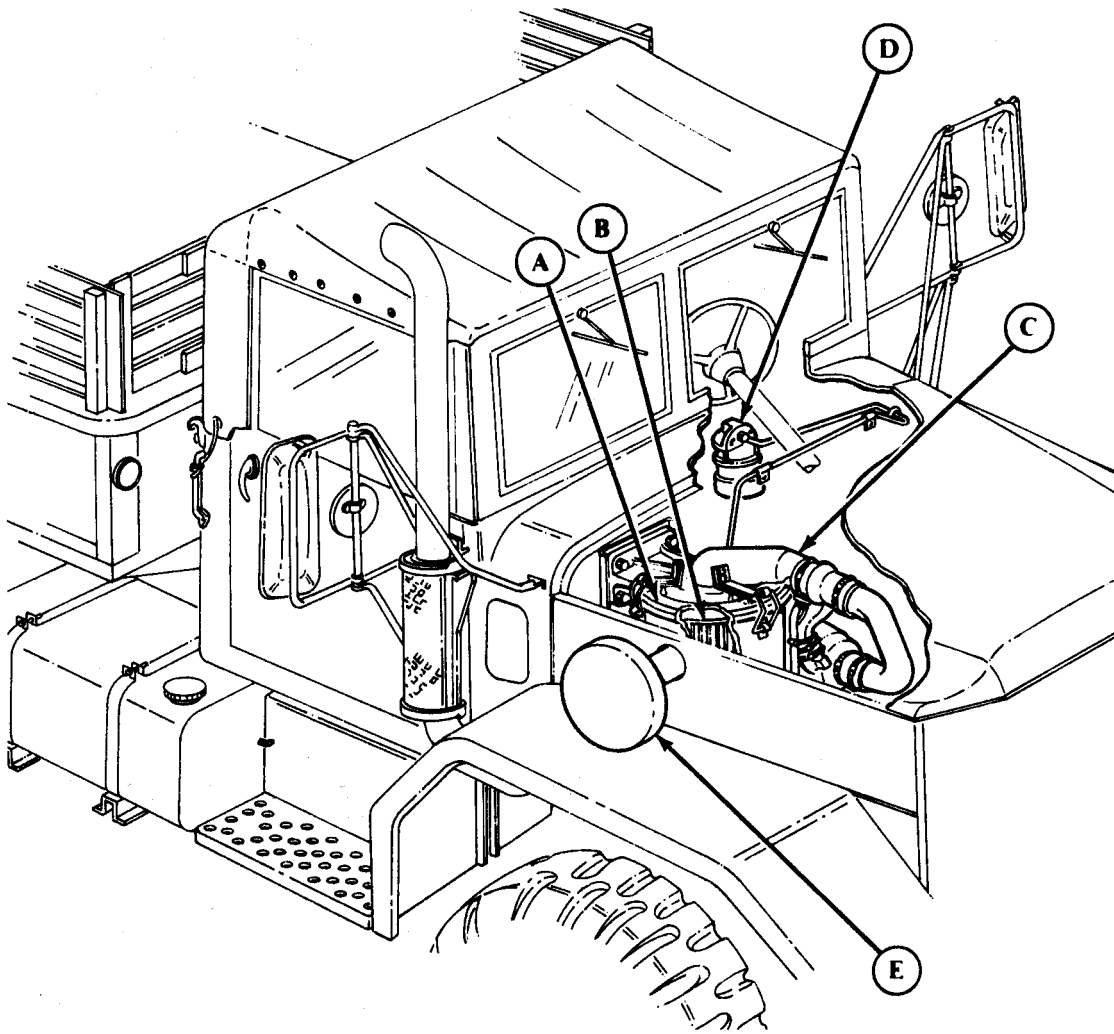

## 1-19. POWER SYSTEMS OPERATION (Contd)

### e. Exhaust System Operation.

The exhaust system directs exhaust gases away from the vehicle and crew compartment. The exhaust configuration is identical for all models covered in this manual with the exception of the M50A2 and M50A3 models which have an exhaust pipe cap. Both configurations are covered here:

- (A) **EXHAUST PIPES** - Direct exhaust gases away from vehicle and crew compartment.
- (B) **EXHAUST PIPE SHIELD** - Protects personnel from hot exhaust pipes.
- (C) **EXHAUST PIPE CAP** (M50A2 and M50A3 only) - Used in cold weather to prevent exhaust gases from escaping from exhaust pipe. This forces gases through the exhaust pipes beneath the water tank keeping the water from freezing. Gases then exit through rear of vehicle.

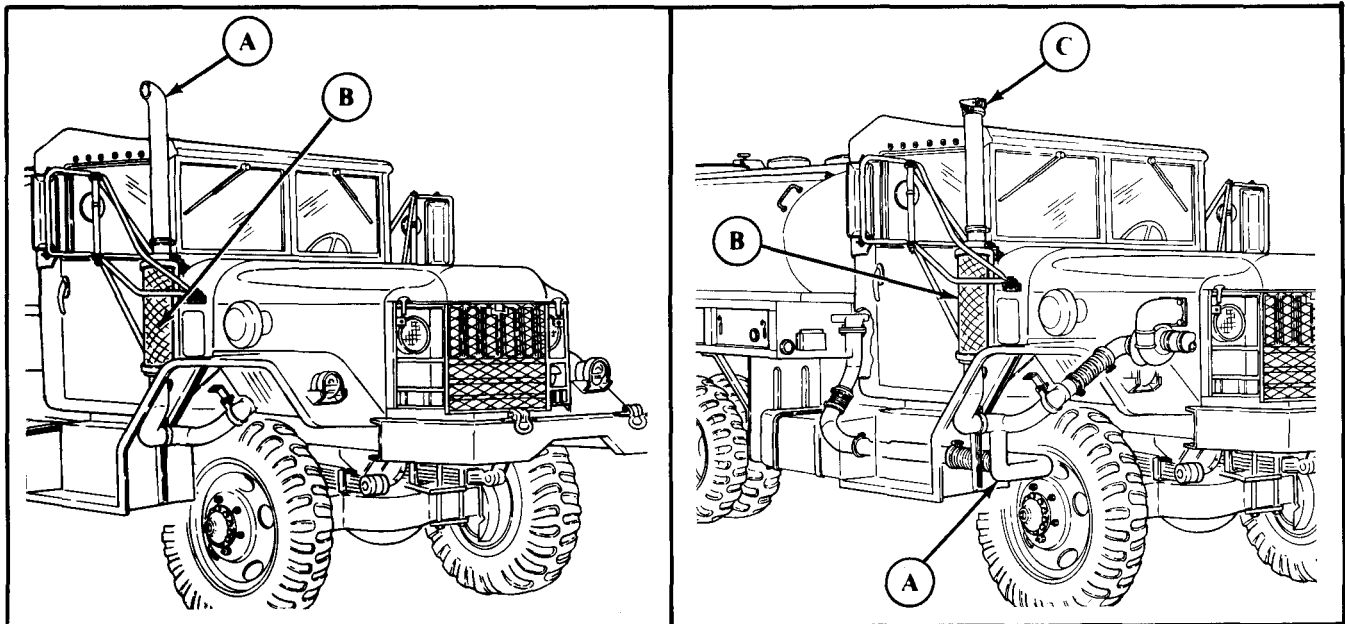

**1-19. POWER SYSTEMS OPERATION (Contd)**

**f. Cooling System Operation.**

The cooling system removes excess heat from the engine. Major components of the cooling system are:

- (A) ENGINE OIL COOLER** - Removes excess heat from engine oil.
- (B) TEMPERATURE GAGE SENDING UNIT** - Detects temperature of engine coolant and sends an electrical signal to temperature gage on instrument panel.
- (C) THERMOSTAT** - Shuts off coolant flow to radiator until temperature reaches 180°F (82°C). Coolant is then allowed to flow to the radiator through the upper radiator hose.
- (D) RADIATOR FILLER CAP** - When removed, filler neck serves as filling point for cooling system. When installed, cap allows cooling system to pressurize.
- (E) RADIATOR** - Directs coolant through a series of fins or baffles so outside air can remove excess heat from coolant.
- (F) UPPER RADIATOR HOSE** - Directs coolant from engine block to radiator when thermostat opens.
- (G) FAN** - Pulls outside air through radiator to remove excess heat from coolant.
- (H) WATER PUMP** - Circulates coolant through cooling system.
- (I) LOWER RADIATOR HOSE** - Directs coolant from radiator back to engine block.

1-19. POWER SYSTEMS OPERATION (Contd)

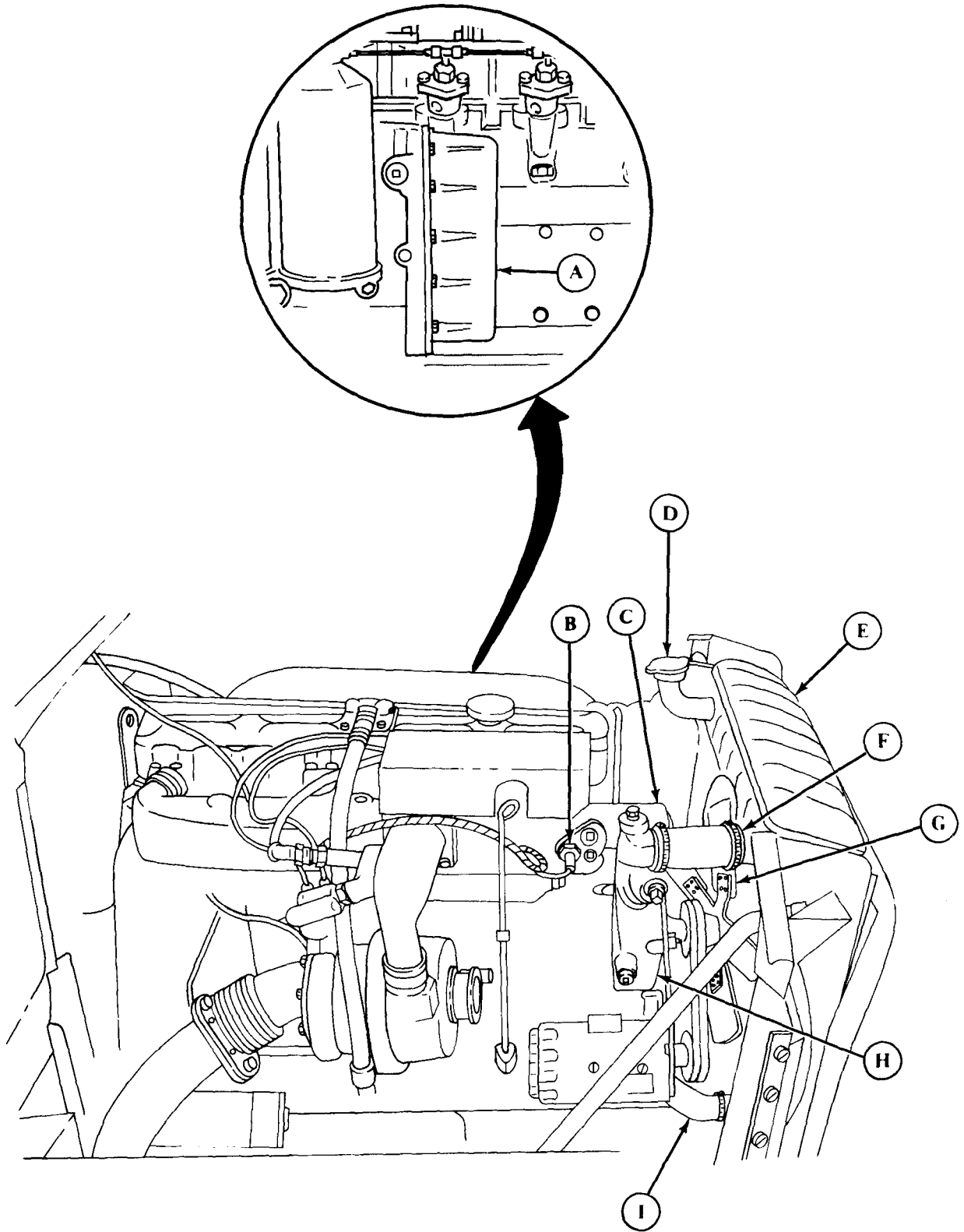

**1-20. ELECTRICAL SYSTEMS OPERATION**

Wires with circuit numbers are shown here for reference only and are NOT to be used for troubleshooting procedures.

The electrical systems include those components that either provide or are powered by electricity. Each of these components will be described as part of the following subsystems:

- a. **Battery System Operation (page 1-56).**
- b. **Starting System Operation (page 1-57).**
- c. **Generating System Operation (page 1-58).**
- d. **Heating System Operation (page 1-58).**
- e. **Gage and Warning System Operation (page 1-59).**

**a. Battery System Operation.**

- (A) BATTERIES** - Two type 6TN batteries store and supply electrical energy. They provide 24-volts DC for the starting system and electrical accessories.
- (B) SLAVE RECEPTACLE** - Provides a convenient place to plug in an external power source to assist in cranking the engine. Used when vehicle batteries are not sufficiently charged.
- (C) ACCESSORY POWER SWITCH** - Connects or disconnects the batteries from the vehicle electrical

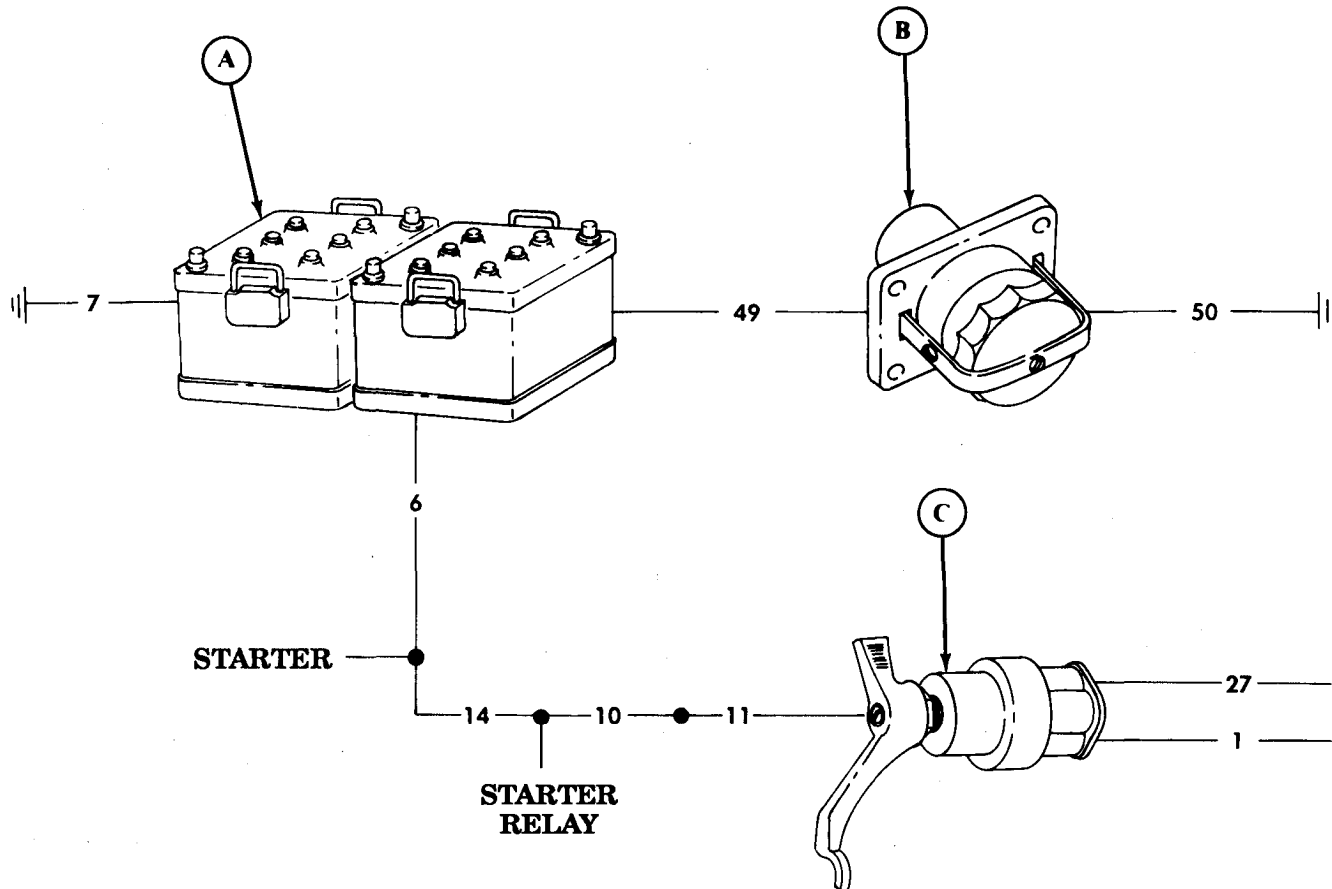

**1-20. ELECTRICAL SYSTEMS OPERATION (Contd)**

**b. Starting System Operation.**

- (A) STARTER SWITCH** - Connects 24-volt battery power to starter motor when pressed.
- (B) STARTER RELAY** - A magnetic switch, actuated by starter switch that allows 24-volt battery power to flow to starter motor.
- (C) STARTER SOLENOID** - Actuates starter motor gear to crank vehicle engine.
- (D) STARTER MOTOR** - Cranks vehicle engine for starting when supplied with 24-volt battery power.

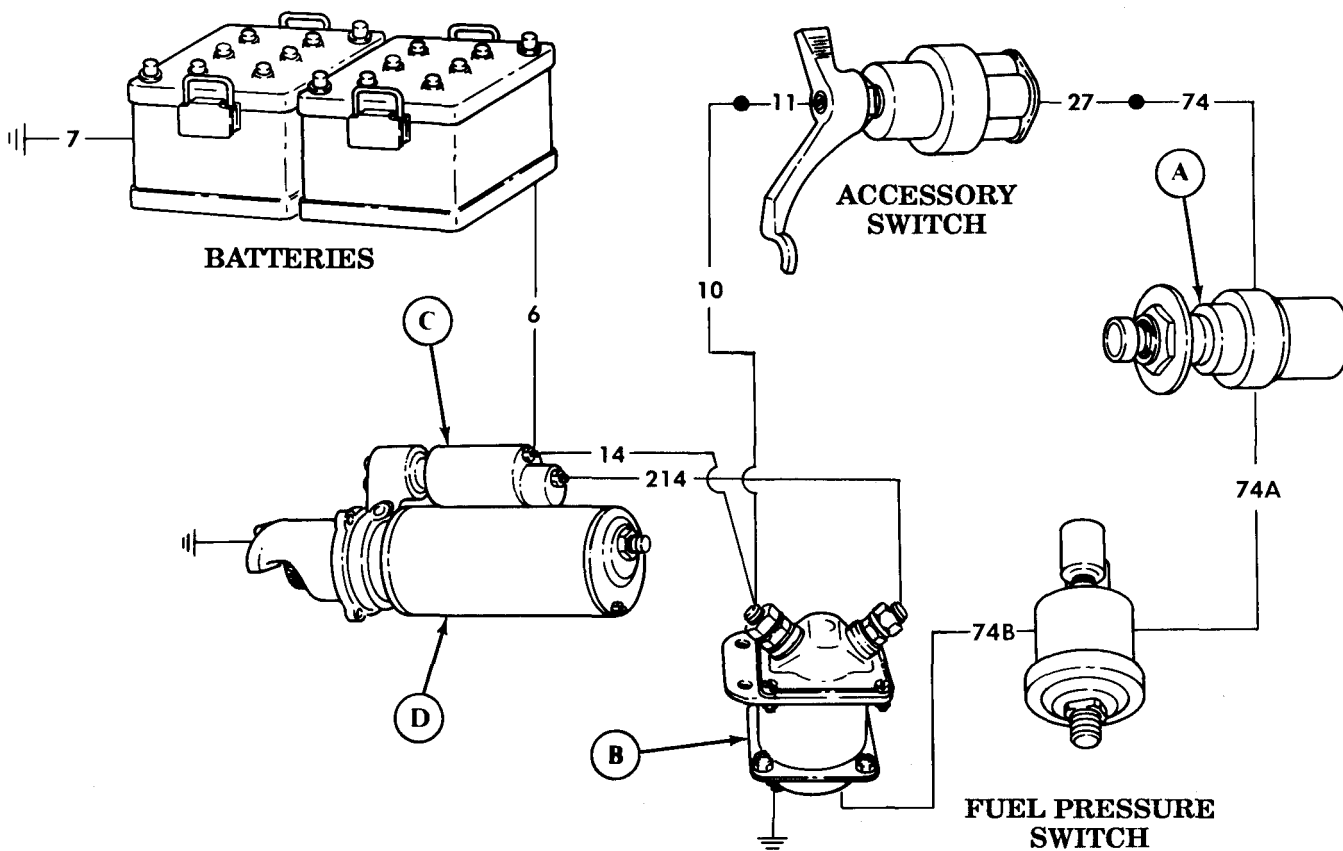

**1-20. ELECTRICAL SYSTEMS OPERATION (Contd)**

**c. Generating System Operation.**

**ALTERNATOR** - Supplies electrical power to operate all electrical accessories and keeps batteries charged when vehicle engine is operating.

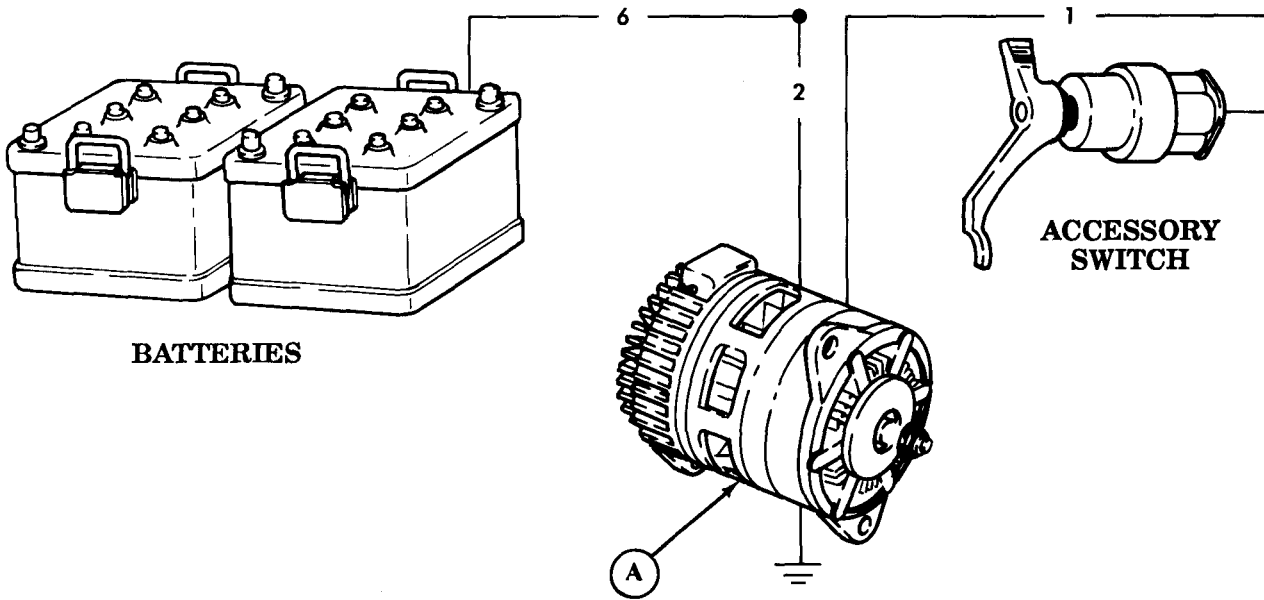

**d. Heating System Operation.**

**HOT WATER PERSONNEL HEATER** - Warms interior of vehicle cab in cold weather. Hot engine coolant circulating through heater is utilized to warm air flowing through heater core. An electric motor, with two speeds, powers a fan to force outside air through heater and into cab.

**PERSONNEL HEATER SWITCH** - Allows heater fan to be operated at two speeds to ensure comfort of personnel in cab.

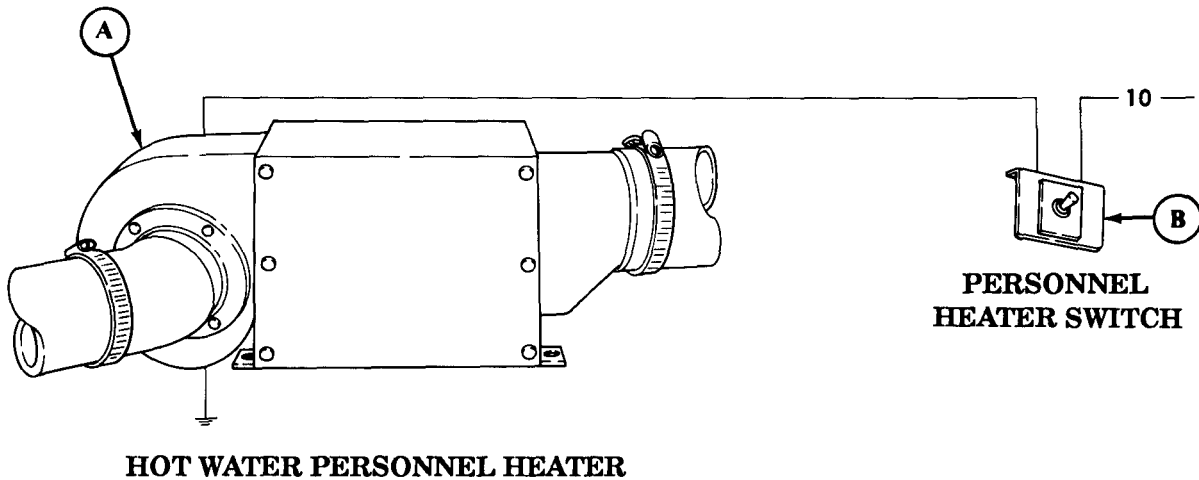

**1-20. ELECTRICAL SYSTEMS OPERATION (Contd)**

**e. Gage and Warning System Operation.**

- (A) OIL PRESSURE GAGE** - Indicates pressure of oil circulating through vehicle engine. Receives electrical current from oil pressure sending unit located on engine block.
- (B) ENGINE TEMPERATURE GAGE** - Indicates temperature of engine coolant circulating through engine. Receives electrical current from engine temperature sending unit located on engine block.
- (C) WARNING BUZZER** - Produces a loud sound to warn vehicle operator that the low air pressure switch has been activated.
- (D) LOW AIR PRESSURE SWITCH** - Activates warning buzzer to sound when pressure in compressed air system is not high enough to safely operate vehicle.
- (E) BATTERY/GENERATOR GAGE** - Indicates amount of voltage in electrical system provided by batteries and alternator.
- (F) FUEL GAGE** - Indicates amount of fuel in fuel tank. Receives electrical current from fuel tank sending unit located in fuel tank.

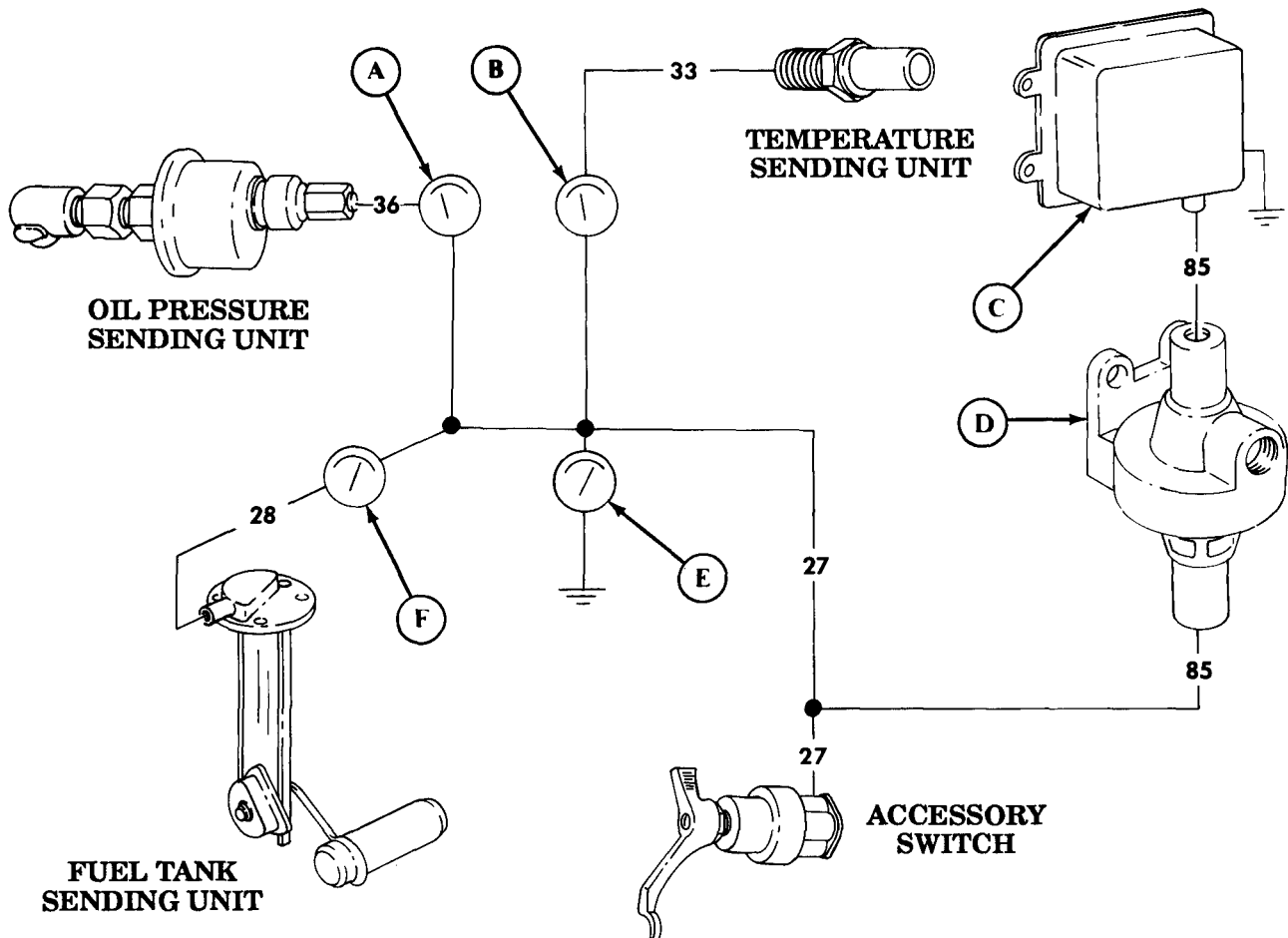



## 1-21. COMPRESSED AIR AND BRAKE SYSTEM OPERATION

The compressed air and brake system takes filtered air, compresses it, and supplies it to various components that enable the operator to slow down or stop the vehicle. This system also supplies compressed air to air-actuated accessories throughout the vehicle such as air horn and windshield wipers. These components and accessories will be described as part of the following systems:

- a. **Compressed Air System Operation (page 1-60).**
- b. **Brake System Operation (page 1-62).**

### a. Compressed Air System Operation.

- (A) AIR COMPRESSOR** - Draws in air, filters it, pressurizes it, and forces it into air reservoirs for storage.
- (B) AIR HORN** - Receives air from the compressed air system in order to operate.
- (C) GOVERNOR** - Automatically opens or closes a valve inside air compressor to ensure a sufficient quantity of compressed air is available for air system.
- (D) WINDSHIELD WIPER MOTOR** - Receives air from the compressed air system to actuate windshield wipers.
- (E) PRESSURE GAGE** - Indicates amount of pressurized air available in the air system. Normal pressure is 85-120 psi (586-827 kPa).
- (F) SAFETY VALVE** - Prevents excessive pressure to build up in air system by releasing air when necessary.
- (G) AIR RESERVOIRS** - Store pressurized air for use in air system and traps water to protect air-operated accessories from corrosion and freezing.

1-21. COMPRESSED AIR AND BRAKE SYSTEM OPERATION (Contd)

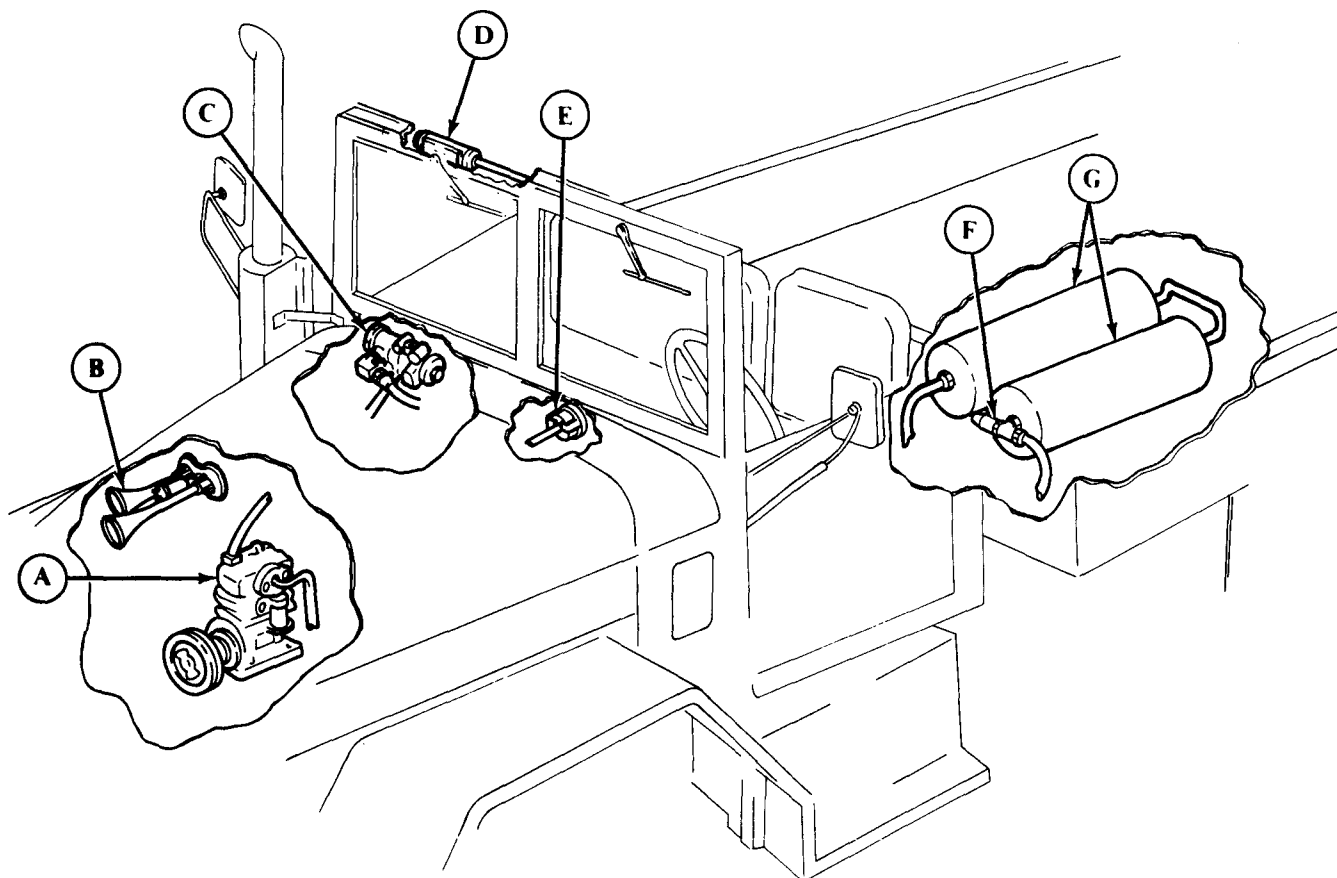

1-21. COMPRESSED AIR AND BRAKE SYSTEM OPERATION (Contd)

**b. Brake System Operation.**

- (A) HYDRAULIC BRAKE LINES** - Directs brake fluid under hydraulic pressure to all six wheel cylinders.
- (B) BRAKE PEDAL** - Operator control for slowing or stopping vehicle. Applies force through brake linkage to master cylinder to actuate vehicle brakes.
- (C) BRAKE LINKAGE** - Transmits brake pedal force to master cylinder.
- (D) HAND CONTROL VALVE (M275A2 only)** - Controls semi-trailer brake system. Allows brakes to be applied and released manually.
- (E) MASTER CYLINDER** - Stores brake fluid and is the filling location for addition of brake fluid. Converts force from brake linkage into hydraulic pressure.
- (F) AIR-HYDRAULIC UNIT** - Combines hydraulic pressure from master cylinder and air pressure from compressed air system to supply increased hydraulic pressure to the vehicle brakes.
- (G) WHEEL CYLINDER** - Converts hydraulic pressure into mechanical force to press brakeshoes against surface of brakedrum.
- (H) BRAKEDRUM** - Encloses wheel cylinder and brakeshoes, and provides surface for brakeshoes to press against.
- (I) BRAKESHOE** - Applies friction to brakedrum to slow or stop rotation of wheels.

1-21. COMPRESSED AIR AND BRAKE SYSTEM OPERATION (Contd)

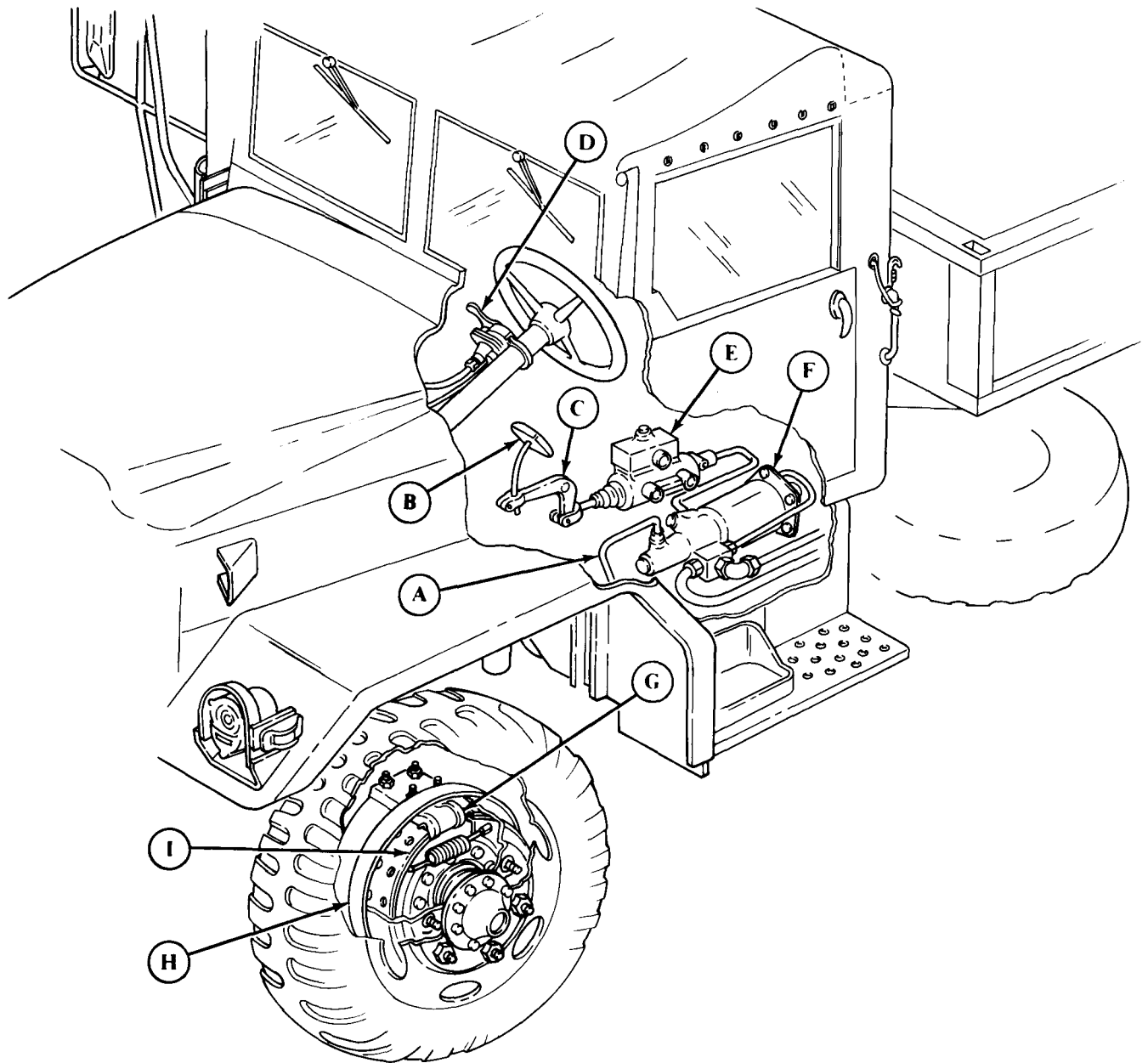

## 1-22. SPECIAL PURPOSE BODIES SYSTEMS OPERATION

The special purpose bodies include controls, hydraulics, and their related equipment that are required to perform specific tasks for outside construction. Each of these parts will be described as part of the following system:

- a. **Dump Body Hydraulic System Operation (M342A2) (page 1-64).**
- b. **Earth Boring, Polesetting, and Rear Winch Systems Operation (M764) (page 1-66).**
- c. **Outrigger Hydraulic System Operation (M764) (page 1-68).**
- d. **Water Tank System Operation (M50A2, M50A3) (page 1-70).**
- e. **Fuel Tank System Operation (M49A2C) (page 1-70).**
- f. **Rear Winch and Pipeline Systems Operation (M756A2) (page 1-72).**

a. **Dump Body Hydraulic System Operation (M342A2).**

The dump body is used on M342A2 vehicles. These models are used to transport and deposit cargo. Dump body hydraulic system converts mechanical power from transmission PTO into fluid power through use of hydraulic pump. Pump draws oil from oil reservoir and then forces it into control valve. This hydraulic pressure raises and lowers dump body. Major components of dump body hydraulic system are:

- (A) DUMP BODY CONTROL LEVER LOCK** - Prevents operation of dump body control lever.
- (B) DUMP BODY CONTROL LEVER** - Permits operation of dump body in four positions. It is pushed forward to lowest position to raise dump body, raised to second lowest position to lock dump body, and raised to third position to lower dump body. When control lever is fully raised to vertical position, dump body is locked in position by use of a hydraulic safety latch.
- (C) HYDRAULIC RESERVOIR** - Storage tank for hydraulic oil.
- (D) CONTROL VALVE** - Four-port valve accepts pressurized oil from hydraulic pump and directs oil to cylinder assembly.
- (E) HYDRAULIC SAFETY LATCH** - Hydraulically-operated in conjunction with dump body control lever. Safety latch locks dump body in the lowered position and releases it when control lever is pushed forward.
- (F) CYLINDER ASSEMBLY** - Consists of two hydraulic cylinders which raise and lower dump body using hydraulic oil pressure.
- (G) CONTROL BOX** - Transmits motion of control rod to actuate control valve.
- (H) HYDRAULIC PUMP** - Driven by PTO propeller shaft, it draws oil from oil reservoir, then pressurizes and directs it to control valve.
- (I) DUMP BODY CONTROL ROD** - Connects control lever to control box.
- (J) TRANSMISSION POWER TAKEOFF PROPELLER SHAFT** - Transmits power from transmission PTO to hydraulic pump.
- (K) DUMP BODY CONTROL LINK** - Connects control valve to transmission PTO.
- (L) TRANSMISSION POWER TAKEOFF** - Attached to side of transmission to provide power for hydraulic pump.

1-22. SPECIAL PURPOSE BODIES SYSTEMS OPERATION (Contd)

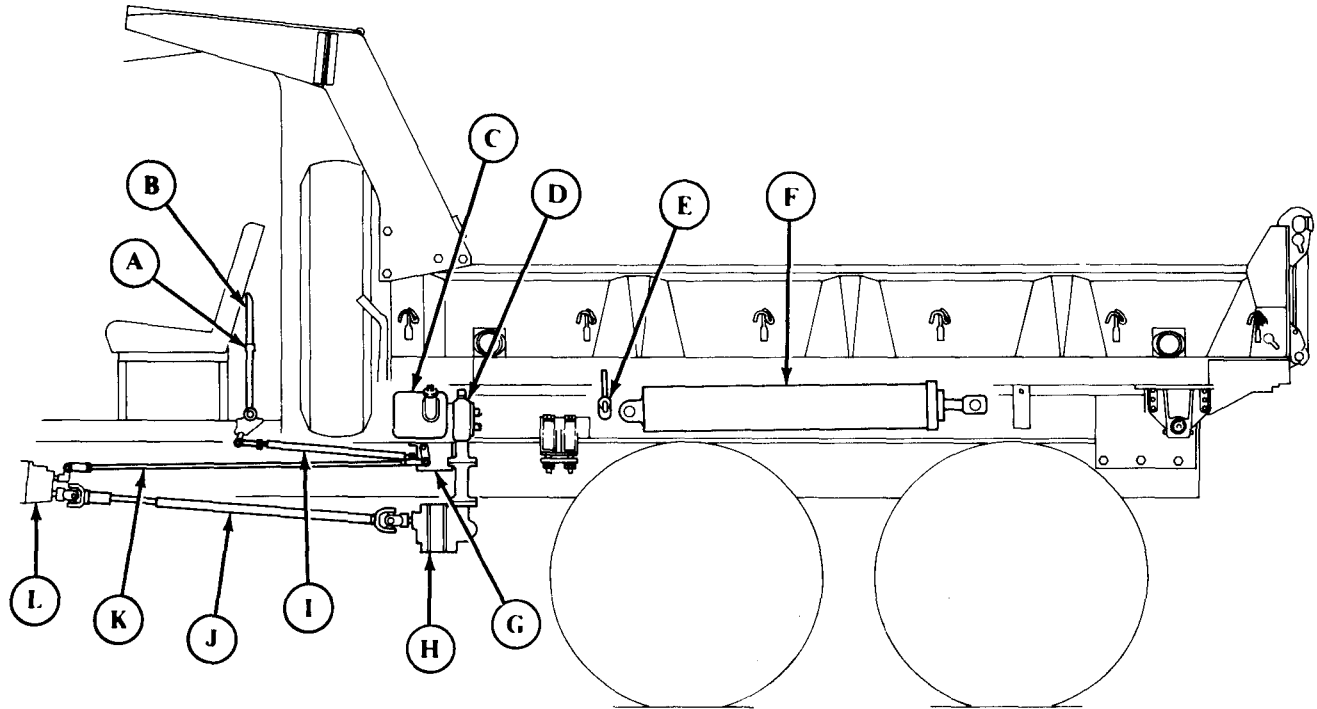

1-22. SPECIAL PURPOSE BODIES SYSTEMS OPERATION (Contd)
--

**b. Earth Boring, Polesetting, and Rear Winch Systems Operation (M764).**

The rear winch and earth boring machine are mechanically driven from the engine and operate individually through a power divider. Rear winch is used primarily with polesetting derrick to position and install poles. The earth boring machine is used to drill select size holes to mount poles. Major components of earth boring machine, polesetting derrick, and rear winch are:

- (A) REAR WINCH CONTROL ROD** - Connects rear winch to power divider.
- (B) REAR WINCH CONTROL** - A manually-operated control lever located inside the cab that permits engagement and disengagement of the rear winch.
- (C) POWER-DIVIDER CONTROL LEVER** - A manually-operated control lever located inside the cab that permits engagement and disengagement of earth boring machine and permits forward and reverse operation of rear winch.
- (D) EARTH BORING AND REAR WINCH CONTROL ROD** - Connects earth boring machine and rear winch control to power divider.
- (E) REAR WINCH** - Reels in or pays out cable for polesetting operations.
- (F) REAR WINCH DRIVE CHAIN** - Transmits mechanical power from power divider to rear winch.
- (G) EARTH BORING CLUTCH** - Allows smooth transfer of power and control for all operations of earth boring machine.
- (H) EARTH BORING CLUTCH CONTROLS** - Operate drive clutch and feed clutch.
- (I) POWER LEVELER** - Positions earth boring machine and polesetting derrick using mechanical power.
- (J) POLESETTING DERRICK** - Raises, positions, and installs poles.
- (K) EARTH BORING MACHINE** - Houses auger bit drive and polesetting derrick.
- (L) MAIN SUPPORT TUBE** - Supports operator's seat and earth boring clutch controls.
- (M) EARTH BORING PROPELLER SHAFT** - Transmits power from power divider to earth boring machine.
- (N) POWER DIVIDER** - Uses mechanical power of the transfer case power takeoff to drive rear winch, earth boring machine, and outriggers.

1-22. SPECIAL PURPOSE BODIES SYSTEMS OPERATION (Contd)

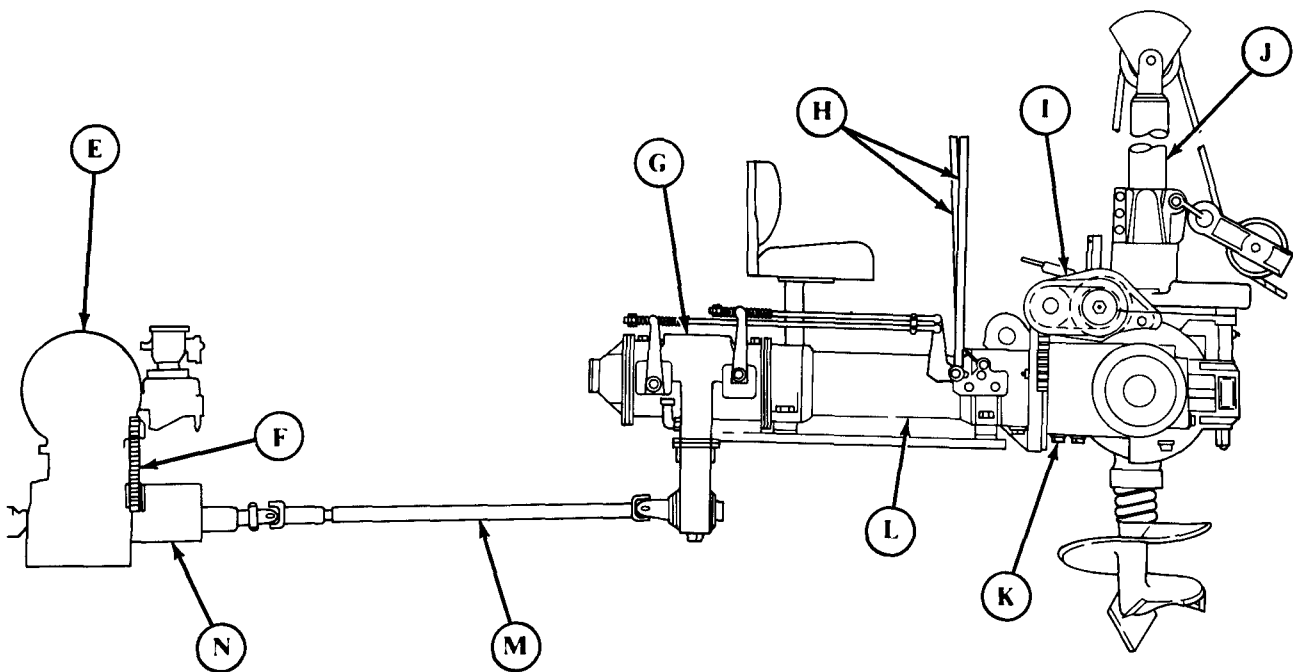
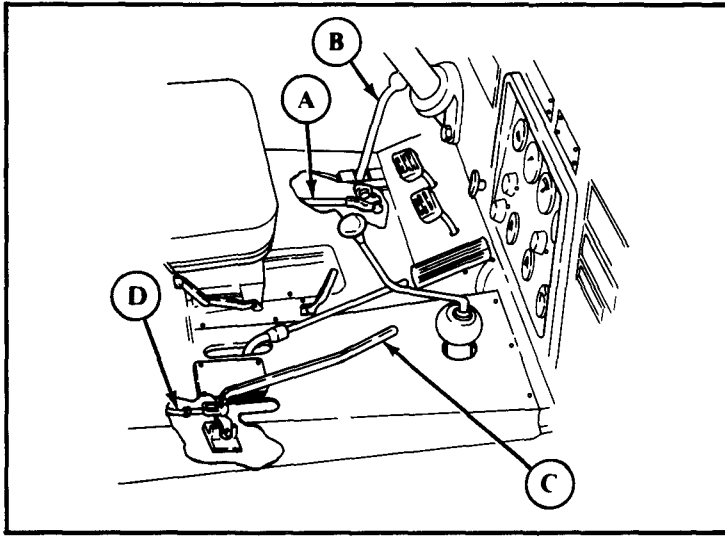



**1-22. SPECIAL PURPOSE BODIES SYSTEMS OPERATION (Contd)****c. Outrigger Hydraulic System Operation (M764).**

The outrigger hydraulic system converts power of engine into fluid power by use of hydraulic pump. At this pump, oil pressure is supplied to left and right outrigger control valves, which direct fluid pressure to outrigger legs. Outrigger legs stabilize the vehicle for earth boring and polesetting operations. The major components of the outrigger hydraulic system are:

- (A) OUTRIGGER CONTROL VALVE** - Consists of two two-way valves that are located directly under the control levers. Valves direct hydraulic oil from hydraulic pump to hydraulic outriggers and back to hydraulic reservoir.
- (B) OUTRIGGER CONTROL LEVERS** - Manual controls attached to the control valve that regulate hydraulic oil flow for raising and lowering outriggers.
- (C) HYDRAULIC OIL RESERVOIR** - Storage tank for hydraulic oil.
- (D) HYDRAULIC PUMP** - Draws oil from hydraulic oil reservoir and directs it to outrigger control valve.
- (E) OUTRIGGER LATCH** - Used to support outrigger in upward position when not in use.
- (F) OUTRIGGER CYLINDER** - A hydraulically-driven piston that extends when control lever is pushed to DOWN position and retracts when control lever is pushed to UP position. This cylinder is contained in the upper portion of the outrigger leg.
- (G) OUTRIGGER LEG** - Two hydraulically-actuated support legs mounted on body at rear of vehicle. Each leg consists of an upper leg, lower leg, and outrigger shoe.

1-22. SPECIAL PURPOSE BODIES SYSTEMS OPERATION (Contd)

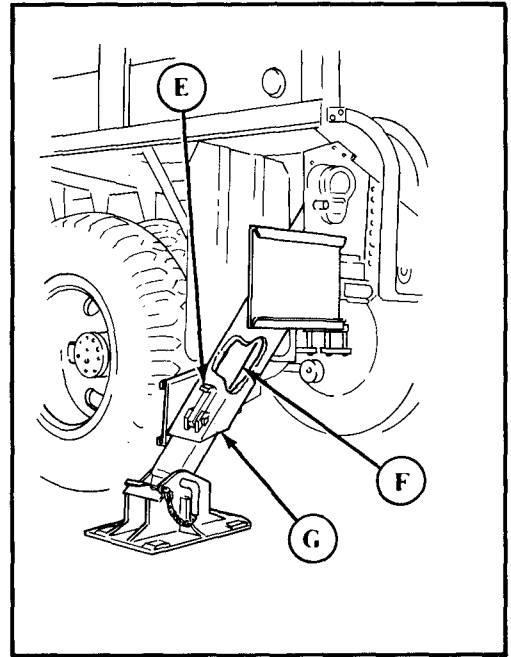
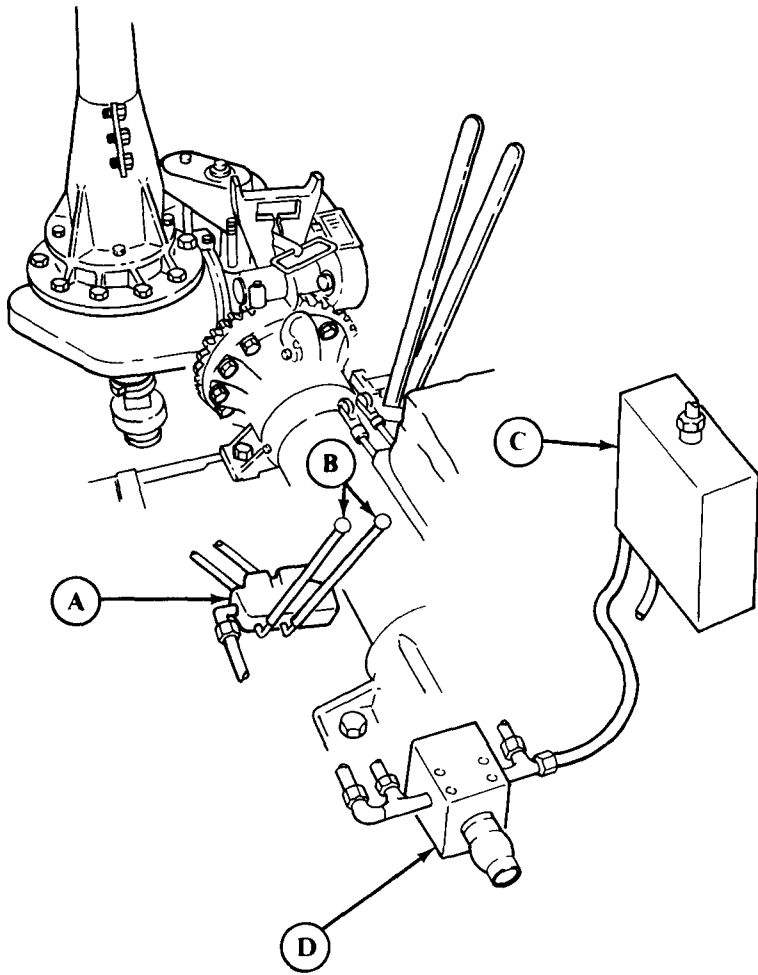

1-22. SPECIAL PURPOSE BODIES SYSTEMS OPERATION (Contd)
--

**d. Water Tank System Operation (M50A2, M50A3).**

Water tanks M50A2 and M50A3 are used for transferring quantities of water. They can operate in cold weather using the exhaust pipe cap which causes engine exhaust to be diverted under the water tank. This warms the water to prevent it from freezing in temperatures below 32°F (0°C). The water tank system differs in operation compared to the fuel tank system operation. Refer to para. 1-22e for description of major water tank components and para. 1-19e for exhaust components.

**e. Fuel Tank System Operation (M49A2C).**

The fuel tank is used to transport and dispense quantities of fuel. Fuel is dispensed with the use of a pump driven by engine power through the transfer case PTO. Major components of fuel tank system are:

- (A) DISCHARGE VALVE CONTROL LEVERS** - Two manual control levers that allow fuel to be discharged from either front or rear compartment of tank body.
- (B) METER** - Indicates quantity of fuel dispensed.
- (C) FUEL FILTER/WATER SEPARATOR** - Separates water from fuel and removes contaminants from fuel before distribution.
- (D) PRESSURE GAGE** - Checks condition of filter elements by indicating difference in pressure between inlet and outlet side of filter.
- (E) SUMP**- Collects water from separator and drains through the manual drain valve.
- (F) GATE VALVES** - Provide a means of turning on or shutting off flow of fuel.
- (G) MANIFOLD DRAIN** - Accepts fuel from discharge pipes and transfers it to pump.
- (H) PUMP**- Draws fuel from tank and discharges it under pressure.
- (I) EMERGENCY CONTROL LEVER RELEASE** - When actuated, it allows discharge valve control levers to return to OFF position which stops flow of fuel.
- (J) STATIC REAR AND GROUNDING WIRES** - Transmits any static electricity produced by fuel flowing through the piping harmlessly to the ground. The grounding wires are pulled out from static reel and attached to ground and vehicle to be fueled.
- (K) MANUAL DRAIN VALVE** - Provides a means to periodically drain water from sump.
- (L) DUMP VALVE** - When opened, water collected by fuel filter/water separator is automatically allowed to drain out.
- (M) FUEL DISCHARGE PIPE** - Receives fuel from tank body compartments and directs it to fuel filter/water separator.
- (N) DISCHARGE VALVE** - Operates by cables and is used to drain front and rear tank compartments.
- (O) FRONT AND REAR DISCHARGE VALVE CABLES** - Connect discharge valve control levers to the two discharge valves.

1-22. SPECIAL PURPOSE BODIES SYSTEMS OPERATION (Contd)

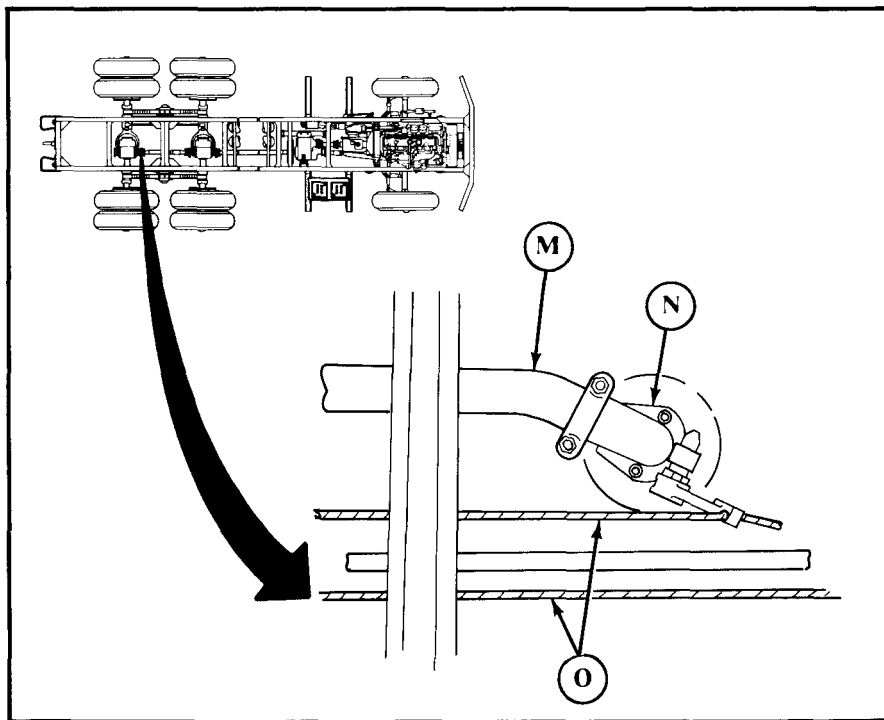
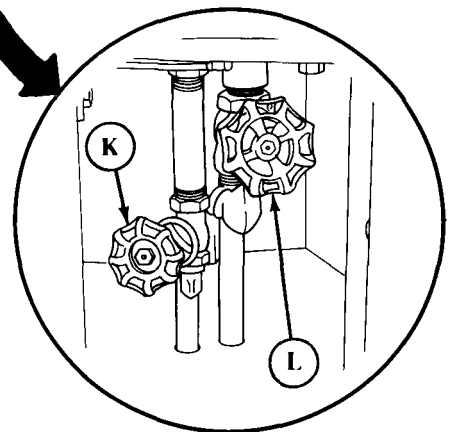
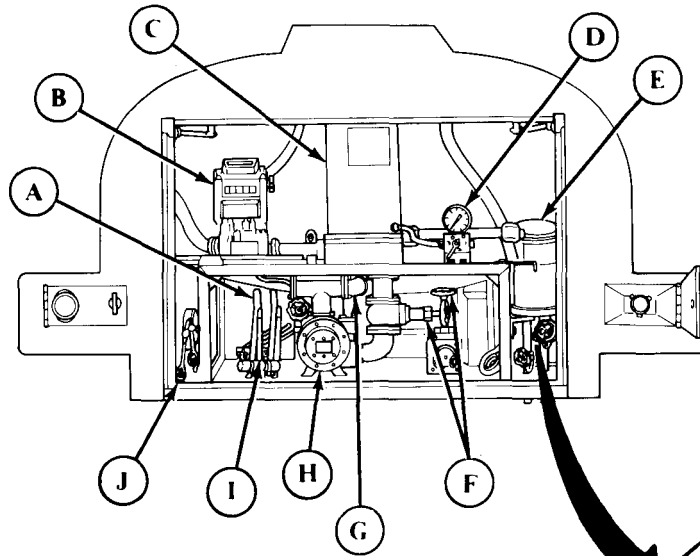

**1-22. SPECIAL PURPOSE BODIES SYSTEMS OPERATION (Contd)**

**f. Rear Winch and Pipeline Systems Operation (M756A2).**

A rear winch is installed on the M756A2 pipeline construction vehicle. Rear winch is used with A-frame to position, assemble, and install pipe. A-frame can be used at rear or either side of vehicle. Major components of the rear winch and pipeline systems are:

- (A) REAR WINCH** - Reels in or pays out winch cable for pipe installation operations.
- (B) TRANSFER CASE POWER TAKEOFF** - Receives power from vehicle engine through the transfer case to provide power directly to rear winch.
- (C) WINCH DRIVE CHAIN** - Transfers power from PTO to winch.
- (D) A-FRAME** - Provides different routing positions for winch cable.
- (E) WINCH CABLE** - Used to hoist, move, and install pipe.

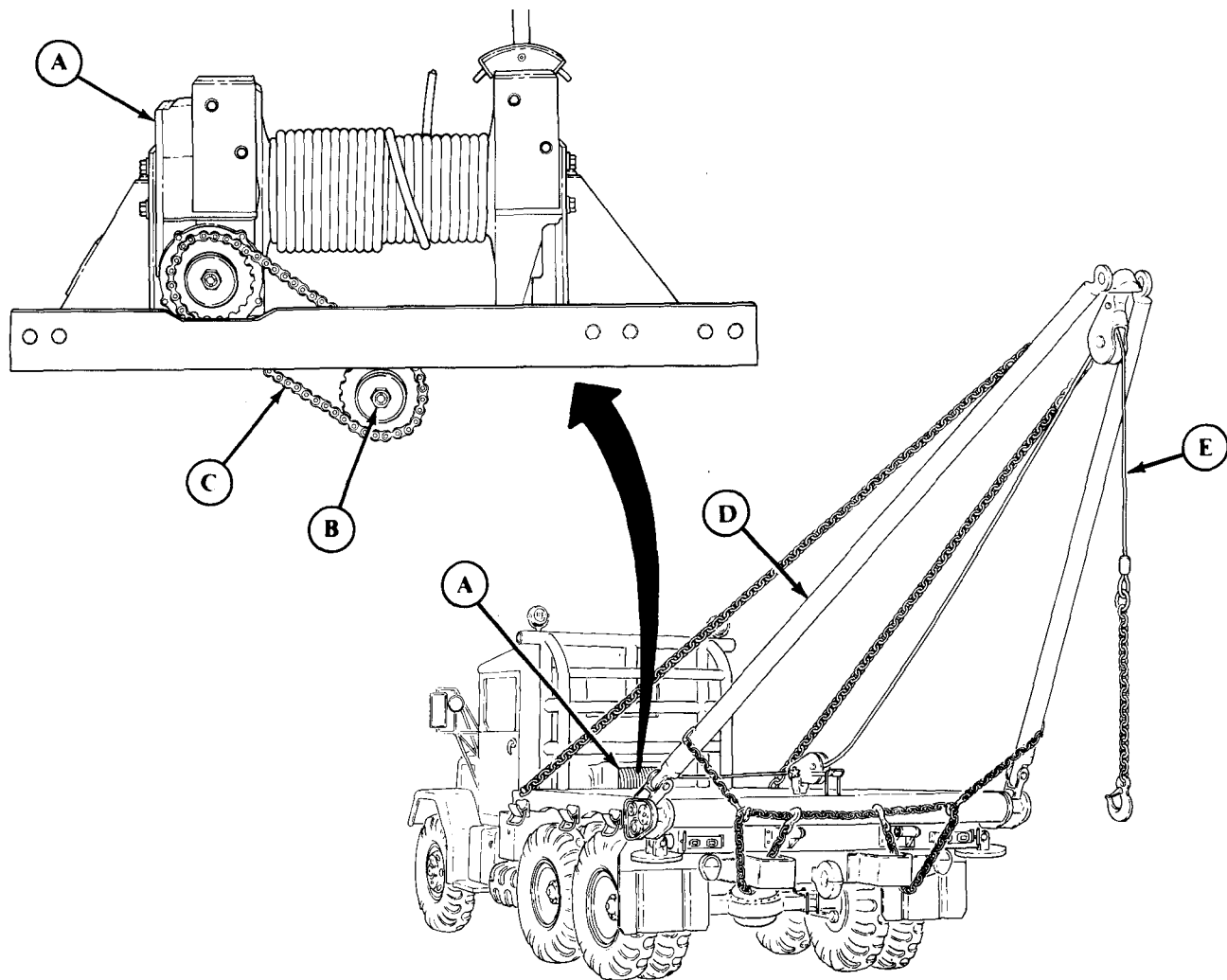

## CHAPTER 2

### SERVICE AND TROUBLESHOOTING INSTRUCTIONS

Section I.	Repair Parts, Special Tools, TMDE, and Support Equipment (page 2-1)
Section II.	Service Upon Receipt (page 2-1)
Section III.	Preventive Maintenance Checks and Services (PMCS) (page 2-2)
Section IV.	Mechanical Systems Troubleshooting (page 2-24)
Section V.	Compressed Air and Brake System Troubleshooting (page 2-52)
Section VI.	Electrical Systems Troubleshooting (page 2-74)
Section VII.	STE/ICE Troubleshooting (page 2-148)

#### Section I. REPAIR PARTS, SPECIAL TOOLS, TMDE, AND SUPPORT EQUIPMENT

##### 2-1. COMMON TOOLS AND EQUIPMENT

For authorized common tools and equipment, refer to the Modified Table of Organization and Equipment (MTOE) applicable to your unit.

##### 2-2. SPECIAL TOOLS, TMDE, AND SUPPORT EQUIPMENT

Special Tools, Special Test, Measurement, and Diagnostic Equipment (TMDE), and Support Equipment used to maintain the vehicles covered in this manual can be found in TM 9-2320-361-20P.

##### 2-3. REPAIR PARTS

Repair parts covering unit maintenance are listed and illustrated in the Repair Parts and Special Tools List (TM 9-2320-361-20P).

#### Section II. SERVICE UPON RECEIPT

##### 2-4. GENERAL

**a.** Upon receipt of a new, used, or reconditioned vehicle, you must determine if the vehicle has been properly prepared for service. The following steps should be performed:

**(1)** Inspect all assemblies, subassemblies, and accessories to be sure they are in proper working order.

**(2)** Secure, clean, lubricate, or adjust as needed.

**(3)** Check all Basic Issue Items (TM 9-2320-361-10) to be sure every item is present, in good condition, and properly mounted or stowed.

**(4)** Follow general procedures for all service and inspections given in TM 9-2320-361-10.

**b.** The operator will assist when performing service upon receipt inspections.

**c.** Refer to TM 9-2320-361-10 when testing equipment for proper operation.

##### 2-5. GENERAL INSPECTION AND SERVICING INSTRUCTIONS

The following steps should be taken while performing general inspection and services:

**(1)** Use TM 9-2320-361-10 and LO 9-2320-209-12-1, as well as other sections of this manual, when servicing and inspecting equipment.

## 2-5. GENERAL INSPECTION AND SERVICING INSTRUCTIONS (Contd)

### WARNING

Drycleaning solvent is flammable and will not be used near open flame. Use only in well-ventilated places. Failure to do so may result in injury to personnel.

(2) Clean all exterior surfaces coated with rust-preventive compounds with drycleaning solvent.

(3) Read "Processing and Deprocessing Record of Shipping, Storage, and Issue of Vehicles and Spare Engines," tag (DD Form 1397) and follow all precautions listed. This tag should be attached to steering wheel, shift column, or battery switch.

### NOTE

If vehicle has been driven to using organization, all of the above work should have been completed.

## 2-6. SPECIFIC INSPECTION AND SERVICING INSTRUCTIONS

The following steps should be taken while performing specific inspections and services:

(1) Perform the semiannual (S), six months, or 6,000 miles (9,654 kilometers), preventive maintenance checks and services listed in section III of this chapter.

(2) Lubricate the vehicle according to LO 9-2320-209-12-1. Do not lubricate gearcases or engine unless processing tag states that the oil is unsuitable for 500 miles (805 kilometers) of operation. If oil is suitable, just check level.

(3) Schedule semiannual service on DD Form 314 (Preventive Maintenance Schedule and Record Card).

(4) If vehicle is delivered with a dry charged battery, activate it according to TM 9-6140-200-14.

(5) Check vehicle coolant level and determine if solution is proper for climate. (Refer to TB 750-651 for preparation of antifreeze solutions.)

## Section III. PREVENTIVE MAINTENANCE CHECKS AND SERVICES (PMCS)

### 2-7. GENERAL

The best way to maintain vehicles covered by this manual is to inspect them on a regular basis so minor faults can be discovered and corrected before they result in serious damage or failure of vehicle and equipment or injury to personnel. This section contains systematic instructions for inspection, adjustment, and correction of vehicle components to avoid costly repairs or major breakdowns. This is referred to as Preventive Maintenance Checks and Services (PMCS).

### 2-8. INTERVALS

#### NOTE

Designated intervals are performed under usual operating conditions. PMCS intervals must be performed more frequently when operating under unusual conditions.

a. Unit maintenance, assisted by operator/crew will perform the checks and services contained in table 2-1 at the following intervals:

(1) **Semiannually (S)**. Every 6 months or 6,000 miles (9,654 kilometers), whichever comes first.

(2) **Annually (A)**. Every 12 months or 12,000 miles (19,308 kilometers), whichever comes first.

(3) **Biennially (B)**. Every 24 months or 24,000 miles (38,616 kilometers), whichever comes first.

b. Perform all (S) inspections in addition to (A) inspections at the time of the annual inspection. Perform all (A) and (S) inspections in addition to (B) inspections at the time of the biennial inspection.

## 2-9. REPORTING REPAIRS

All uncorrected defects will be recorded on Equipment Inspection and Maintenance Worksheet, DA Form 2404, in accordance with DA Pam 738-750.

## 2-10. GENERAL SERVICE AND INSPECTION PROCEDURES

**a.** While performing specific PMCS procedures, make sure items are correctly assembled, secure, serviceable, not worn, not leaking, and adequately lubricated as defined below:

**(1)** An item is **CORRECTLY ASSEMBLED** when it is in proper position and all parts are present.

**(2)** When wires, nuts, washers, hoses, or attaching hardware cannot be moved by hand, wrench, or prybar, they are secure.

**(3)** An item is **UNSERVICEABLE** if it is worn beyond established wear limits or is likely to fail before the next scheduled inspection.

**(4)** An item is **WORN** if there is play between joining parts, or warning and caution plates are not readable.

**(5)** **LEAKS.** TM 9-2320-361-10 contains definitions of class I, II, and III leaks and their effect on vehicle operation.

**(6)** If an item meets the requirements specified by lubrication order, LO 9-2320-209-12-1, then it is **ADEQUATELY LUBRICATED**.

**b.** Where the instruction "Tighten" appears in a procedure, you must tighten with a wrench to the given torque value even when the item appears to be secure.

### **WARNING**

Drycleaning solvent is flammable and will not be used near open flame. Use only in well-ventilated places. Failure to do so may result in injury to personnel.

**c.** Where the instruction "clean" appears in a procedure, you must use drycleaning solvent, specification P-D 680, to clean grease or oil from metal parts. After the item is cleaned, rinsed, and dried, apply a light grade of oil to unprotected surfaces to prevent rusting. To clean rubber and plastic materials, use soap and water.

## 2-11. SPECIFIC PMCS PROCEDURES

**a.** The preventive maintenance checks and services for which you are responsible are provided in table 2-1. The checks and services listed are arranged in logical order requiring minimal time and effort on your part.

**b.** The following columns read across on the PMCS schedule:

**Item Number.** Provides logical order for PMCS performance and is used as a source number for DA Form 2404, on which your PMCS results will be recorded.

**(2) Interval.** Shows a bullet (•) opposite each item number to indicate when that check is to be performed. The bullet will be repeated when consecutive item numbers are to be inspected during the same interval. Interval columns include:

**(a) Semiannually (S).** Every 6 months or 6,000 miles (9,654 kilometers), whichever comes first.

**(b) Annually (A).** Every 12 months or 12,000 miles (19,308 kilometers), whichever comes first.

**(c) Biennially (B).** Every 24 months or 24,000 miles (38,616 kilometers), whichever comes first.

**(3) Item To Be Inspected.** Lists the system, common name, or location of the item to be inspected.

**(4) Procedures.** Provides instructions for servicing, inspection, replacement, or adjustment, and in some cases, having an item repaired at a higher level. If a defect is found, repair, fill, replace, or adjust as needed.



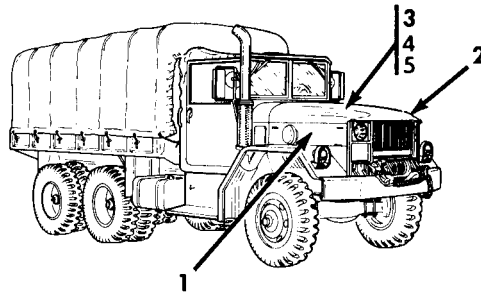

Table 2-1. Preventive Maintenance Checks and Services.

Item No.	Interval			Item to be Inspected	Procedures
	S	A	B		
					<b>PRIOR TO ROAD TEST</b>
1	•			Starter	Perform all Before Operation checks listed in TM 9-2320-361-10, "Preventive Maintenance Checks and Services".
2	•			Engine and engine compartment	Start engine (TM 9-2320-361-10). While starting engine, listen for unusual noises and difficult cranking.
3	•			Throttle control	<p>a. Observe response to accelerator pedal (4). Listen for unusual noises. Observe for hesitation, varying idle speed, and sticking or binding of accelerator pedal.</p> <p>b. Be alert for excessive vibration and the smell of fuel, oil, coolant, and exhaust.</p> <p>Check travel and free movement of throttle control (1) by watching accelerator pedal (4). When throttle control (1) is pulled out all the way, accelerator pedal (4) will be down against stop screw. Check that throttle control (1) does not bind or stick in any position.</p>
					<b>ROAD TEST</b>
					Perform all During Operation checks listed in TM 9-2320-361-10 in addition to those that follow. Drive the vehicle at least 5 miles (8 kilometers) over varied terrain both on and off road. This will provide ample time to check reported malfunctions and to locate unreported malfunctions.

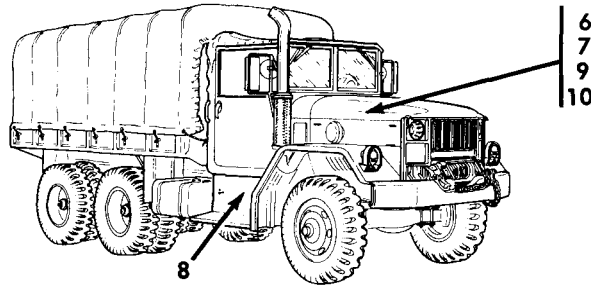

Table 2-1. Preventive Maintenance Checks and Services (Contd).

Item No.	S-Semiannually			A-Annually	B-Biennially	Procedures
	Interval	S	A	B	Item to be Inspected	
4	•				Clutch	Check clutch pedal (5) for 1.5-2.0 in. (3.8-5.0 cm) free travel. If not within limits, adjust clutch pedal (para. 3-10).
5	•				Brakes	<p>a. Check brake pedal (3) to make sure it stops no less than 2.0 in. (5.0 cm) above floor. If brake pedal (3) stops less than 2 in. (5.0 cm) above floor, check brakeshoe adjustment (para. 8-8).</p> <p>b. Check brake pedal (3) for 0.2-0.5 in. (.06-1.25 cm) free travel. If brake pedal adjustment is required (para. 8-14).</p>
6	•				Steering system	<p>a. Check steering wheel (2) and make sure it does not exceed more than 1 in. (2.5 cm) free play.</p> <p>b. Turn steering wheel (2) through full range and check for binding or excessive steering.</p>
7	•				Engine stop control	<p>Stop engine (TM 9-2320-361-10).</p> <p style="text-align: center;"><b>AFTER ROAD TEST</b></p> <p>Perform all after-operation weekly and monthly checks in TM 9-2320-361-10 PMCS. Then make the following inspections in the order given, including kit items on vehicles so equipped.</p> <p style="text-align: center;"><b><u>WARNING</u></b></p> <ul style="list-style-type: none"> <li>Do not smoke, have open flame, or make sparks when performing battery maintenance. Batteries may explode causing severe injury to personnel.</li> <li>Remove all jewelry such as rings, dog tags, bracelets, etc. If jewelry or disconnected battery ground cable contacts battery post, a direct short can result, causing damage to equipment or severe injury to personnel.</li> </ul>
8	Ž				Batteries	Check and record specific gravity of each cell. Check electrolyte level. If low, add distilled water. Inspect battery cables for frays, splits, corrosion, and security. Clean top of batteries and lightly coat terminals with grease (TM 9-6140-200-14).
9	Ž				Air cleaner indicator	Test air cleaner indicator for proper operation (para. 3-16).
10				•	Data, caution, and warning plates	Inspect for completeness, security, and readability. Replace if necessary.

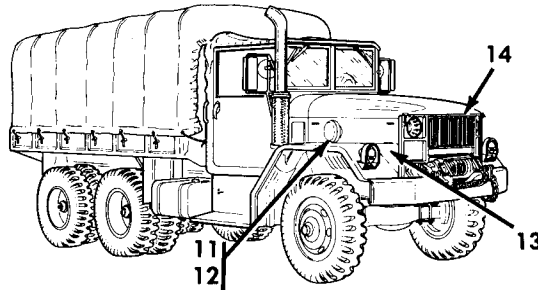
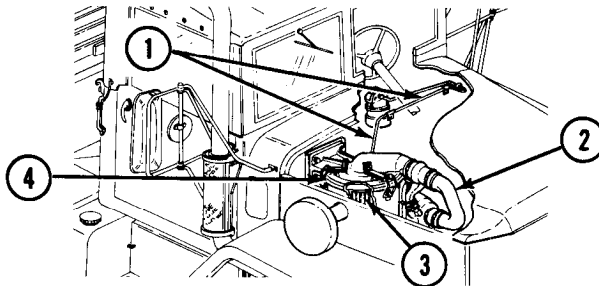

Table 2-1. Preventive Maintenance Checks and Services (Contd).

Item No.	Interval			Item to be Inspected	Procedures
	S	A	B		
					<b>ENGINE COMPARTMENT</b> <b>WARNING</b> If NBC exposure is suspected, all air filter media should be handled by personnel wearing protective equipment. Consult your unit NBC officer or NBC NCO for appropriate handling or disposal instructions. <b>NOTE</b> Open hood and secure with retaining latch (TM 9-2320-361-10).
11	•			Air intake system	a. Inspect air cleaner (4) and air intake tubes (2) for security or damage. b. Check air cleaner indicator tube (1) for kinks or bends. c. Inspect air cleaner element (3) for tears or presence of dirt and oil. Clean or replace as necessary (para. 3-14).
12	•	•		Starter and starter wiring	a. Inspect starter (5) mounting nuts for security. If loose, tighten nuts 70-80 lb-ft (95-108 N·m). b. Inspect starter (5) wiring for loose and corroded connections. If corrosion is present, clean. If loose, tighten.
13	•			Alternator and alternator wiring	a. Inspect alternator (9) for secure mounting. b. Inspect alternator (9) wiring for burned or frayed wires and loose or broken terminal connections. If loose, tighten. If burned, frayed, or broken, replace or repair wiring (para. 4-50).
14	•			Cooling system	a. Inspect radiator (6) for clogged or bent fins and protruding objects. Clean radiator and straighten bent fins.



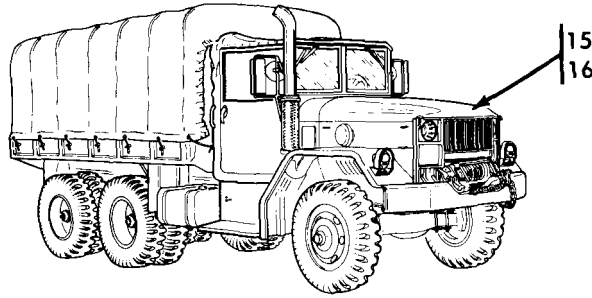
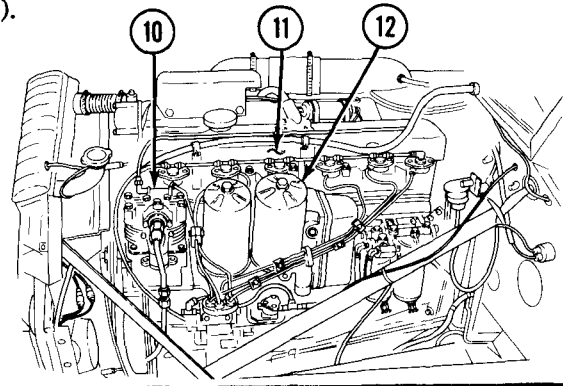
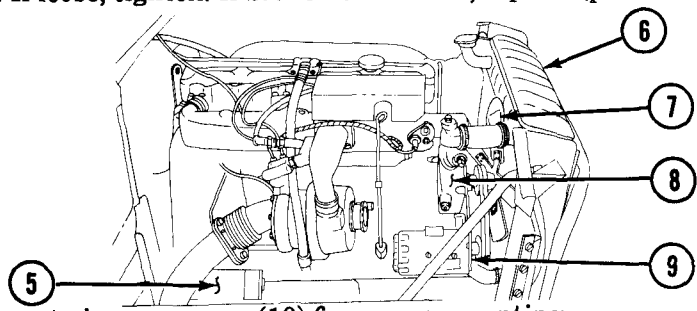

Table 2-1. Preventive Maintenance Checks and Services (Contd).

Item No.	Interval			Item to be Inspected	Procedures
	S	A	B		
	•				<p>b. Test coolant freeze point.</p> <p>c. Inspect radiator (6) for corrosion. If excessive corrosion is found, flush radiator. Flush radiator and cylinder block every four years (para. 3-41).</p> <p>d. Inspect fan (7) for cracks and missing or loose rivets and screws. Replace fan (7) if defective (para. 3-40).</p> <p>e. Inspect radiator mounts for cracks, breaks, and loose conditions. If loose, tighten. If broken or cracked, replace (para. 3-42).</p> <p>f. Inspect water pump (8) for cracks, leaks, and loose conditions. If loose, tighten. If broken or cracked, replace (para. 3-47).</p>
15	•			Air compressor	<p>Inspect air compressor (10) for secure mounting.</p>
16	•			Engine lubrication	<p>a. Check oil dipstick for metal particles at end of dipstick. If metal particles are present, notify your supervisor.</p> <p>b. Check rocker arm cover (11) and oil pan areas for leaks. If leaking, notify your supervisor.</p> <p>c. Inspect oil filter (12) for leaks. If leaking, tighten center bolt 60 lb-ft (81 N·m).</p>



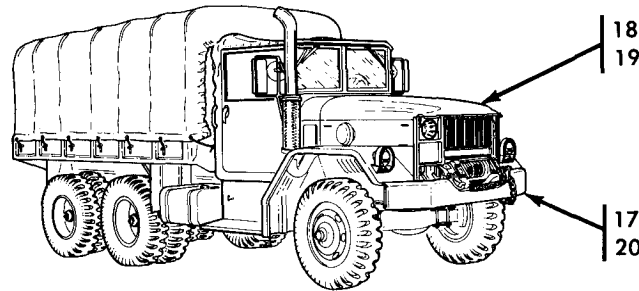

Table 2-1. Preventive Maintenance Checks and Services (Contd).

S-Semiannually

A-Annually

B-Biennially

Item No.	Interval			Item to be Inspected	Procedures
	S	A	B		
17	•			Vibration damper	<p>a. Make sure inner member and outer member alinement marks (1) are alined. If not, notify your supervisor.</p> <p style="text-align: center;"><b>WARNING</b></p> <p style="text-align: center;">Stay clear of moving parts. Failure to do so may result in injury or death to personnel.</p> <p>b. With engine started and at idle (TM 9-2320-361-10), visually inspect vibration damper (2) for wobble and runout. If wobble or runout exist, notify your supervisor.</p> <p>The diagram shows a vibration damper assembly. Callout 1 points to the inner member and callout 2 points to the outer member.</p>
18	•			Engine crankcase breather adapter	Remove engine crankcase breather adapter (4) and clean (para. 3-7).
19	•			Manifold heater	Inspect tubing (3) and wiring (5) for loose connections and leaks. If leaking or loose, tighten.
20	•			Engine pads and mounts	Inspect front engine mounts for loose screws, broken, split, or missing rubber pads (6). If loose, tighten 65-70 lb-ft (88-95 N·m). If pads (6) are defective, replace (para. 3-2).

The diagram shows the engine compartment. Callout 3 points to a manifold heater, callout 4 points to the engine crankcase breather adapter, callout 5 points to a manifold heater tube, and callout 6 points to an engine pad or mount.

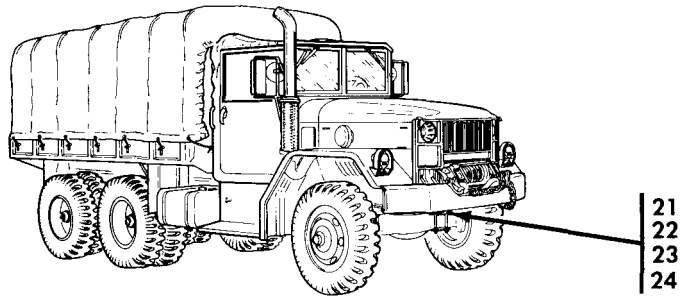
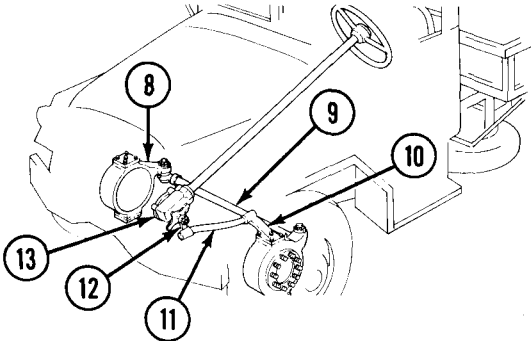
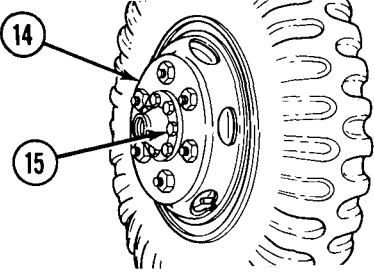

Table 2-1. Preventive Maintenance Checks and Services (Contd).

Item No.	S-Semiannually			A-Annually	B-Biennially	Procedures
	S	A	B			
21		•				<p>Inspect steering gear (13) for security. If loose, tighten mounting screws 62-68 lb-ft (84-92 N·m).</p>
22	•					<p style="text-align: center;"><b>UNDERSIDE OF VEHICLE</b></p> <p>a. Inspect steering knuckles (7), tie rod (9), steering arm (10), drag link (11), and pitman arm (12) for breaks, cracks, and loose conditions. If loose, tighten. If broken or cracked, notify your supervisor.</p> <p>b. Inspect wheel bearing for loose conditions. If loose, adjust (para. 9-5).</p> <p>c. Inspect steering stops (8) for bends and breaks. If bent or broken, notify your supervisor.</p>
23	•					<p>Check front end alinement. Correct toe-in is <math>13 \pm .06</math> in. (<math>3.2 \pm 1.6</math> cm). Adjust toe-in if incorrect (para. 9-7).</p> 
24	•					<p>a. Inspect front axle flanges (14) for leaks and loose mounting screws (15). If loose or leaking, tighten screws (15) 60-80 lb-ft (81-108 N·m).</p> 

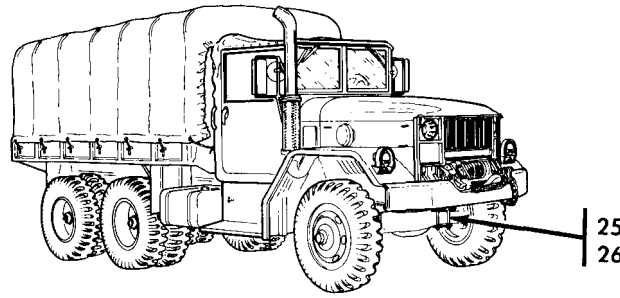

Table 2-1. Preventive Maintenance Checks and Services (Contd).

Item No.	Interval			Item to be Inspected	Procedures
	S	A	B		
25	•	•		Front suspension	<p>b. Inspect axle housing (4) for cracks that may cause leaks. If axle housing is cracked, notify your supervisor.</p> <p>c. Remove breather from front axle and clean (para. 7-8).</p> <p>a. Inspect springs (1) and shackles (2) for cracks, breaks, and security. If spring U-bolts are loose, tighten 190-230 lb-ft (258-312 N·m). If cracked or broken, replace (para. 7-13).</p> <p>b. Inspect shock absorbers (3) and mounting brackets for looseness, wear, cracks, and leaks. Replace leaking shock absorbers (3) if more than a class I leak is found (LO 9-2320-209-12-1). If worn or cracked, replace (para. 7-20).</p> <p>c. Check front axle drainplug for leaks. If loose, tighten (LO 9-2320-209-12-1).</p>
	•				
26	•	•		Brake system	<p>a. Check brakeshoe (5) condition. If brakeshoes (5) are worn beyond .331 in. (8.4 mm), replace (para. 8-7).</p> <p>b. Inspect master cylinder (6) and wheel cylinders (10) to make sure they are not loose, leaking, or damaged. If loose, tighten. If damaged, replace (paras. 8-9 and 8-10).</p> <p>c. Inspect air-hydraulic cylinder (7) to make sure it is not loose, leaking, or damaged. If loose, tighten. If damaged, replace (para. 8-11).</p> <p style="text-align: center;"><b>WARNING</b></p> <p>Ensure new, longer front hydraulic brake lines, currently used on 5-ton trucks, are installed on all 2-1/2-ton trucks. Old, shorter front hydraulic brake lines are subject to failure during full steering travel and must be replaced with new, longer front hydraulic brake lines. Failure to do this will result in injury or death to personnel.</p>
	•				

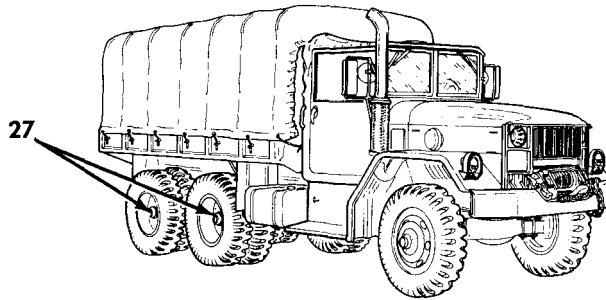
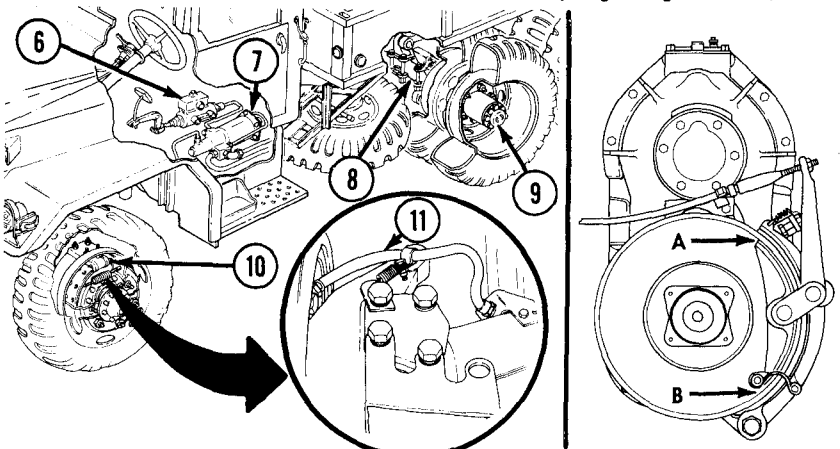

Table 2-1. Preventive Maintenance Checks and Services (Contd).

Item No.	Interval			Item to be Inspected	Procedures
	S	A	B		
27	•			Forward-rear axle and rear-rear axle	<p>d. Inspect all flexible hydraulic brake hoses for bulges, pinches, cracks, crimping, chafing, abrasions, or leaks. If any of these conditions exist, replace or reposition to prevent failure. Check front brake hoses (11) for loose or missing fittings, and make sure they are long enough to allow full steering travel. If brake hose (11) is too short it must be replaced with new longer hose (paras. 8-15 and 8-16).</p> <p>e. Inspect parking brakeshoes for wear. Replace both brakeshoes if lining thickness is 0.188 in. (4.76 mm) or less (para. 8-3).</p> <p>f. Inspect parking brake cable, lever, and brakeshoe assembly for binding and loose or missing components. Tighten components if loose or replace if missing or damaged (chapter 8, section I).</p> <p>g. Check parking brakeshoe clearance to parking brakedrum (A and B). If clearance is not 0.015 in. (0.381 mm), adjust (para. 8-3).</p>  <p>a. Inspect axle housings (8) for cracks that may cause leaks. If axle housing is cracked, notify your supervisor.</p> <p>b. Check fittings and plugs for leaks. If loose, tighten (LO 9-2320-209-12-1).</p> <p>c. Remove breather valves and clean (para. 7-7).</p> <p>d. Inspect axle housings (8) for leaks at differential housing and pinion seal. If leaking, notify your supervisor.</p> <p>e. Inspect axle flange (9) for leaks. If leaking, tighten loose screws 60-80 lb-ft (81-108 N-m).</p>
	•				
	•				
	•				
	•				



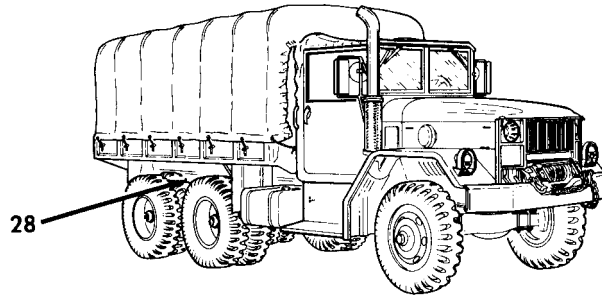

Table 2-1. Preventive Maintenance Checks and Services (Contd).

Item No.	Interval			Item to be Inspected	Procedures
	S	A	B		
28	•			Rear suspension	<p><b>a.</b> Inspect torque rods (1) for looseness or damage. If loose, notify your supervisor.</p> <p>(1) Place flat end of crowbar or pinch bar between torque rod (1) and mounting bracket (2).</p> <p>(2) Push on end of bar until hook end moves 4 - 6 in. (101.6-152.4 mm).</p> <p>(3) Release pressure on bar: If torque rod does not return to original position, replace (para. 7-22).</p>

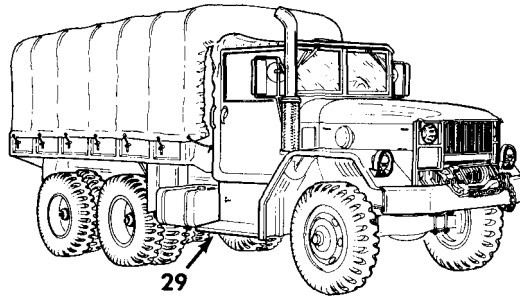
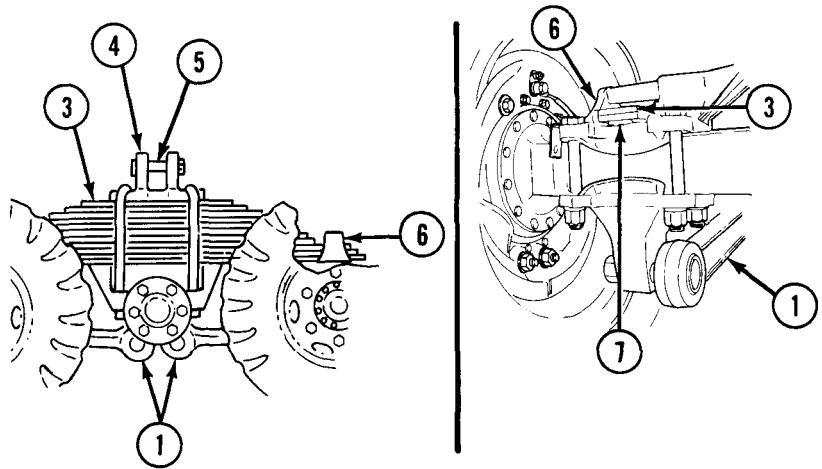

Table 2-1. Preventive Maintenance Checks and Services (Contd).

Item No.	Interval			Item to be Inspected	Procedures
	S	A	B		
	•				<p>b. Inspect springs (3) for cracks, breaks, and security. If spring U-bolts are loose, tighten 190-220 lb-ft (258-298 N-m). If cracked or broken, replace (para. 7-17).</p> <p>c. Inspect front and rear spring wear pads (7) for wear. Replace wear pads (7) if spring (3) is rubbing against spring bracket (6) (para. 7-21).</p> <p>d. Test spring seat bushing by placing jack under torque rods (1) and raise vehicle until springs (3) are raised off wear pad (7) but not touching spring bracket (6). Position prybar between U-bolt saddle (4) and lifting pin (5). Pull up on prybar. If there is play, inspect bushings for damage or adjust as necessary.</p>
29	•			<p>Frame and cross-members</p>	<p>a. Squirt oil on suspected loose rivet(s). Clean excess oil and tap rivet with hammer. A loose rivet will squirt oil from underside. If loose or broken rivets are found, notify your supervisor.</p> <p>b. Check spare tire carrier for security, completeness of assembly, and proper operation.</p>



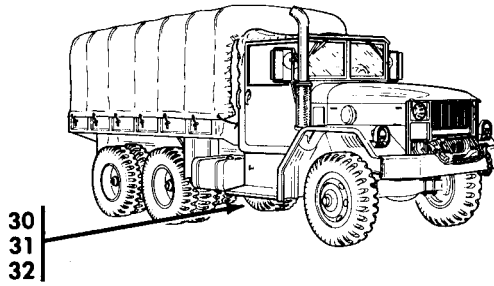
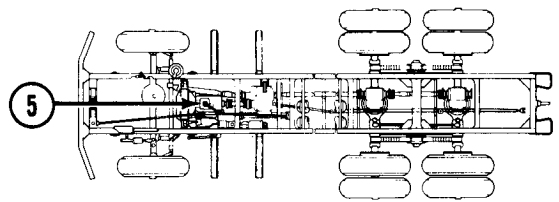
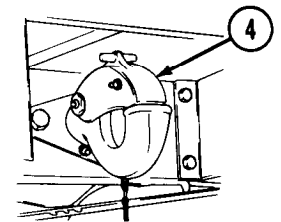
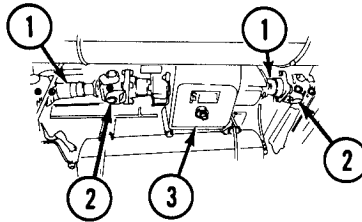

Table 2-1. Preventive Maintenance Checks and Services (Contd).

Item No.	Interval			Item to be Inspected	Procedures
	S	A	B		
30		•		Propeller shafts	<p>c. Check operation of towing pintle hook (4). Inspect pintle and bracket for cracks and breaks. If cracked or broken, replace (para. 10-4).</p> <p>a. Check all propeller shafts (1) for bends, cracks, and loose conditions. If loose, tighten mounting screws 90-120 lb-ft (122-163 N·m). If cracked or broken, replace (para. 7-2).</p> <p>b. Inspect universal joints (2) to make sure there is no play, broken retaining clips and bearing cups, or missing lubrication fittings (para. 7-4).</p>
31		•		Transmission	<p>a. Inspect transmission (5) for loose screws and plugs that may cause leaks. If loose, tighten.</p> <p>b. Inspect transmission (5) for missing or loose mounting screws. If loose, tighten 23-26 lb-ft (31-35 N·m). If missing, notify your supervisor.</p> <p>c. Remove transmission breather valve and clean (para. 5-2).</p>
32		•		Transfer case	<p>a. Inspect transfer case (3) for oil leaks, cracks, and loose screws that may cause leaks.</p> <p>b. Inspect transfer case (3) for loose mounting screws and nuts. If transfer case stud nuts are loose, tighten 125-135 lb-ft (169-183 N·m). If transfer case support bracket screws and nuts are loose, tighten 65-70 lb-ft (88-95 N·m).</p> <p>c. Remove transfer case breather valve and clean (para. 6-4).</p>



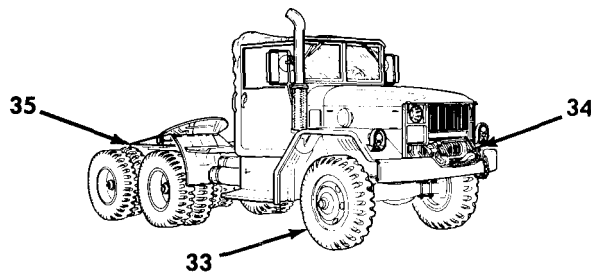

Table 2-1. Preventive Maintenance Checks and Services (Contd).

Item No.	S-Semiannually			A-Annually			B-Biennially		
	Interval			Item to be Inspected			Procedures		
	S	A	B						
33	•			Wheel and tire assemblies			Check each tire for wear using tire tread depth gage. Tread depth should not be less than 0.13 in. (3.18 mm) as indicated on tire tread depth gage (TM 9-2610-201-14). Refer to TM 9-2610-200-14 and TM 9-2610-201-14 for specific instructions for matching tires and tire rotation.		
34		•		Front winch			<p style="text-align: center;"><b>SPECIAL PURPOSE BODIES AND EQUIPMENT</b></p> a. Inspect front winch for secure mounting and broken or missing parts. If loose, tighten (para. 13-5). b. Perform drag brake and automatic brake test (paras. 13-2 and 13-4).		
35		•		Rear winch			a. Inspect rear winch for secure mounting and broken or missing parts. If loose, tighten (para. 13-18). b. Perform drag brake and automatic brake test (paras. 13-2 and 13-4).		

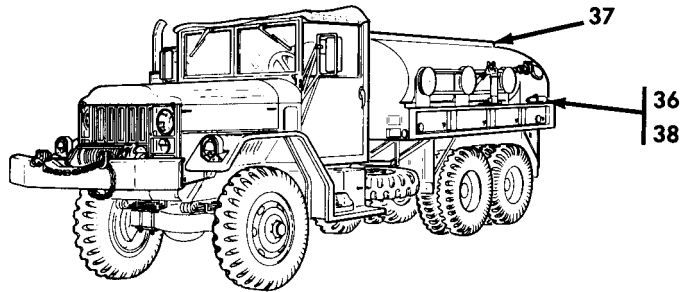

Table 2-1. Preventive Maintenance Checks and Services (Contd).

Item No.	Interval			Item to be Inspected	Procedures
	S	A	B		
	S-Semiannually				A-Annually
					B-Biennially
36	•			Fuel pump system and gravity discharge system	<p style="text-align: center;"><b>M49A2C FUEL TANK TRUCK</b></p> <p>a. Check all pipes (1), caps (2), and couplings (3) to make sure they are not loose or leaking.</p> <p style="text-align: center;"><b>NOTE</b></p> <p>Refer to TM 9-2320-361-10 for operating procedures when doing the following checks:</p> <p>b. Pump enough fuel from one compartment to another to make sure fuel system works properly and there are no unusual noises, vibrations, or leaks.</p> <p>c. Gravity discharge fuel from one compartment to a clean container. Empty enough fuel to make sure gravity discharge system works properly and does not leak.</p> <div style="text-align: center;"> </div>
37	•			Tank body	<p>a. Inspect manhole covers (4) and filler caps (6) to make sure they seal properly and are not damaged.</p> <p>b. Inspect chains (7) and locks (5) to make sure they are not missing or damaged.</p>

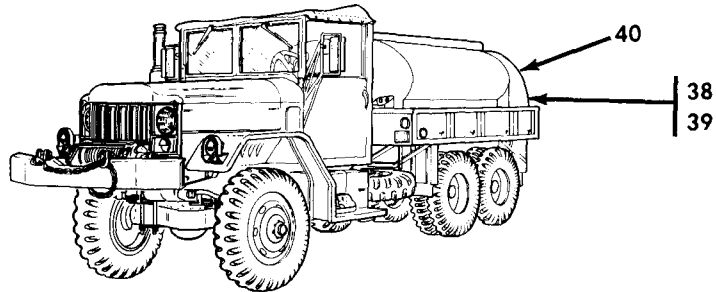
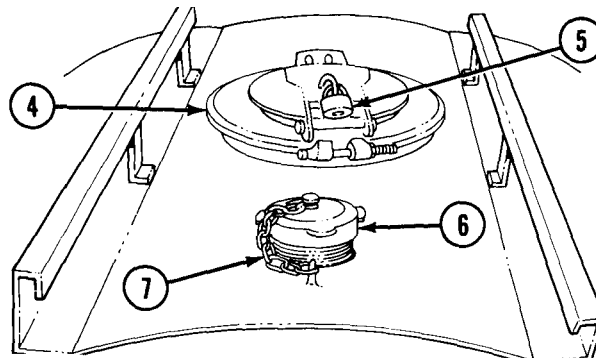

Table 2-1. Preventive Maintenance Checks and Services (Contd).

Item No.	S-Semiannually			Item to be Inspected	A-Annually	B-Biennially
	S	A	B			
38	•			Water separator filter	Replace fuel filter elements (para. 12-41) and Go-No-Go fuses (para. 12-21).	
39	•			Water pump system and gravity discharge system		<p><b>M50A2 AND M50A3 WATER TANK TRUCKS</b></p> <p>NOTE</p> <p>Refer to TM 9-2320-361-10 for operating procedures when doing the following checks:</p> <p><b>a.</b> Pump enough water from one compartment to another to make sure water pump system works properly, and there are no unusual noises, vibrations, or leaks.</p> <p><b>b.</b> Gravity discharge water from one compartment to a clean container. Empty enough water to ensure gravity discharge system works properly and does not leak.</p>
40	•			Tank body	Inspect manhole covers (4) and filler caps (6) to ensure they seal properly and are not damaged.	



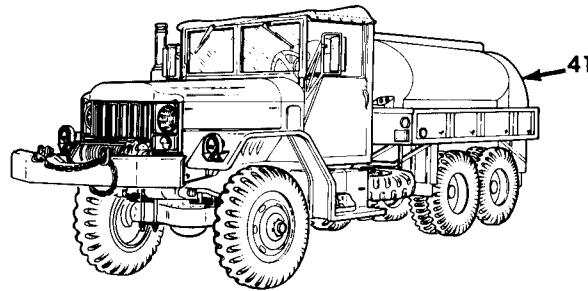

Table 2-1. Preventive Maintenance Checks and Services (Contd).

Item No.	Interval			Item to be Inspected	Procedures
	S	A	B		
41	•			Exhaust bypass system	<p style="text-align: center;"><b><u>CAUTION</u></b></p> <p>Exhaust bypass system will overheat tank body if there is less than 10 in. (25.0 cm) of water in either compartment. Make sure level is above 10 in. (25.0 cm) before checking exhaust bypass system.</p> <p>Check exhaust bypass system for proper operation as follows:</p> <p style="text-align: center;"><b><u>WARNING</u></b></p> <p>Do not touch hot exhaust system components with bare hands. Injury to personnel may result.</p> <ol style="list-style-type: none"> <li>a. Close and latch front exhaust shutoff valve (1).</li> <li>b. Open rear exhaust shutoff valve (2).</li> <li>c. Start engine (TM 9-2320-361-10).</li> <li>d. Check to make sure exhaust gases are coming out of rear exhaust.</li> <li>e. Stop engine (TM 9-2320-361-10).</li> <li>f. Open front exhaust shutoff valve (1).</li> <li>g. Close rear exhaust shutoff valve (2).</li> </ol> <div style="text-align: center;"> </div>

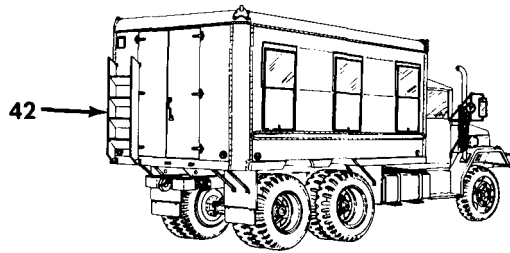
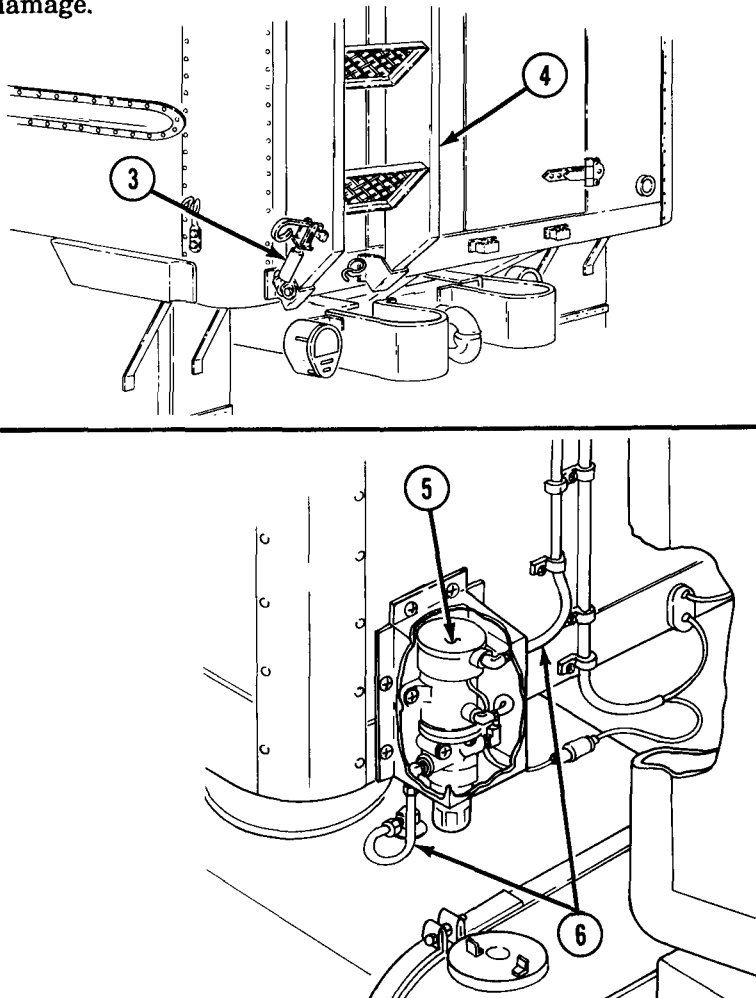

Table 2-1. Preventive Maintenance Checks and Services (Contd).

Item No.	Interval			Item to be Inspected	Procedures
	S	A	B		
42	•			Van body hardware	<p><b>M109A3 AND M185A3 SHOP VAN TRUCKS</b></p> <p>a. Inspect access ladder (4) and mounting hardware (3) for breaks, bends, or damage.</p> <p>b. Inspect heater fuel pump (5) and fuel lines (6) for leaks or damage.</p> 



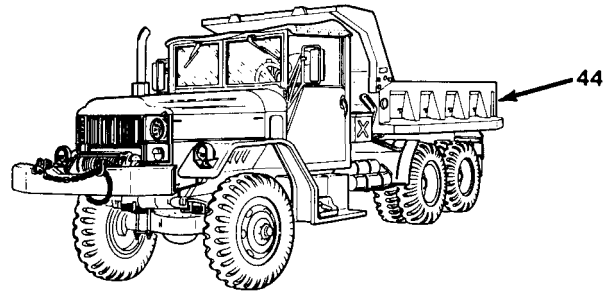
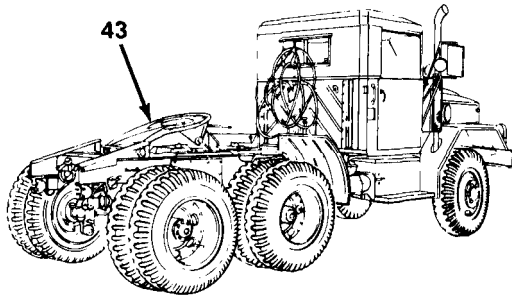
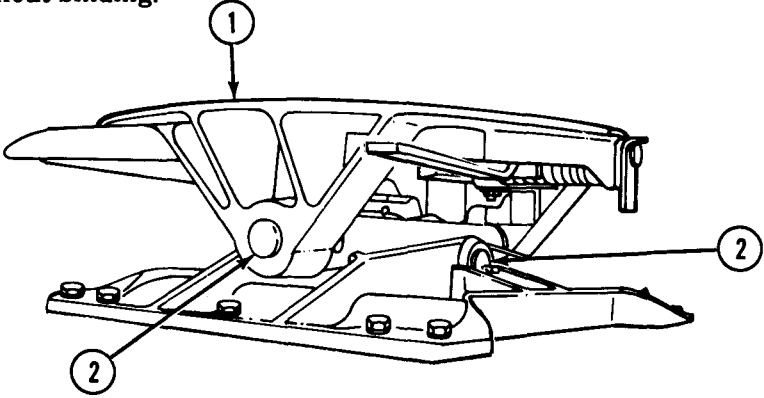
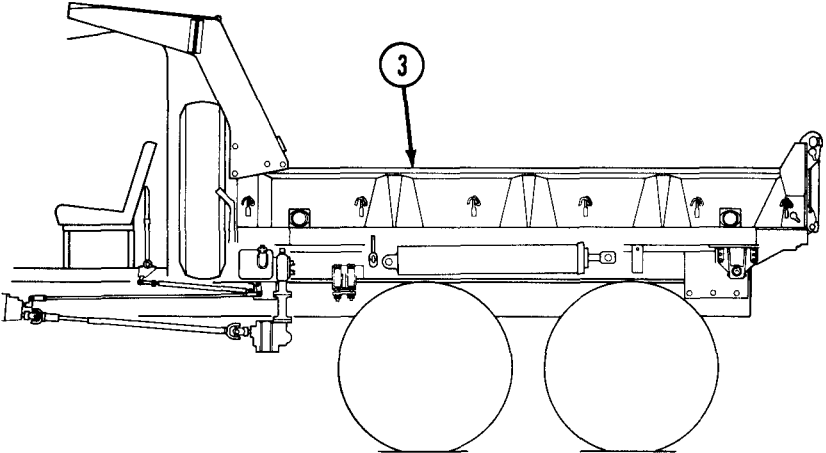

Table 2-1. Preventive Maintenance Checks and Services (Contd).

Item No.	S-Semiannually			A-Annually	B-Biennially	Procedures
	S	A	B			
43	•					<p><b>M275A2 TRACTOR TRUCK</b></p> <p>a. Inspect face of fifth wheel (1) for cracks, breaks, or damage. If damaged, replace (para. 12-113).</p> <p>b. Inspect pivot pins (2) and ensure fifth wheel (1) moves without binding.</p> 
44	•					<p><b>M342A2 DUMP TRUCK</b></p> <p>a. Inspect dump body (3) to ensure it aligns with frame.</p> <p>b. Inspect dump body (3) for loose or missing mounting screws.</p> 

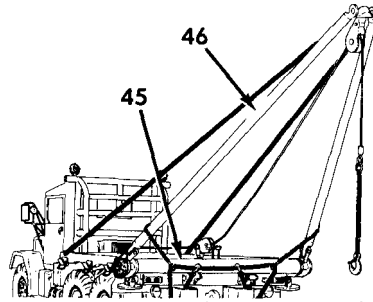
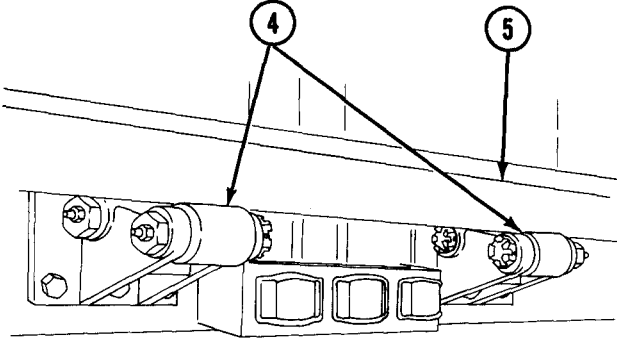
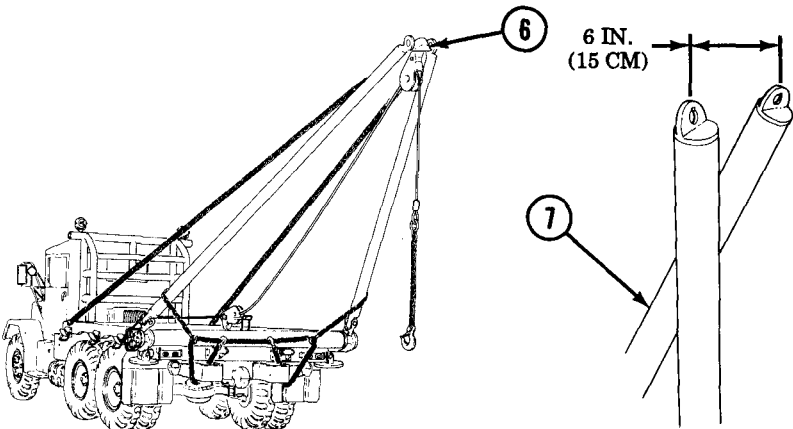

Table 2-1. Preventive Maintenance Checks and Services (Contd).

S-Semiannually

A-Annually

B-Biennially

Item No.	Interval			Item to be Inspected	Procedures
	S	A	B		
45	•			Tailboard roller	<p><b>M756A2 PIPELINE CONSTRUCTION TRUCK</b></p> <p>a. Check tailboard roller (5) to ensure it does not bind by turning it two or three turns.</p> <p>b. Check tailboard roller (5) end play (movement from side to side). If end play is less than .030 in. (.76 mm), adjust (para. 12-102).</p> <p>c. Check clearance between tailboard roller (5) and auxiliary rollers (4). Clearance should be .020 in. (.51 mm).</p> 
	•				
	•				
46	•			A-frame	<p>Put ginpoles (7) in position and take out trunnion (6). Inspect ginpoles (7) for bends or if they overlap more than 6 in. (15 cm).</p> 

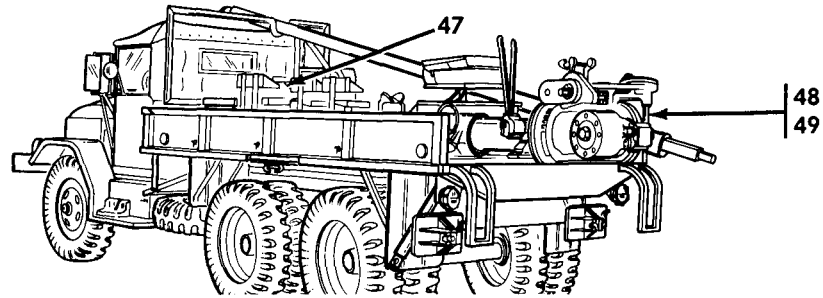

Table 2-1. Preventive Maintenance Checks and Services (Contd).

S-Semiannually

A-Annually

B-Biennially

Item No.	Interval			Item to be Inspected	Procedures
	S	A	B		
47	•			Rear winch level wind	<p><b>M764 EARTH BORING AND POLESETTING TRUCK</b></p> <p>Check tension on cable level wind drive chains as follows:</p> <ol style="list-style-type: none"> <li>Remove level wind drive chain covers (paras. 13-14 and 13-15).</li> <li>Reduction drive chains (1) and (3) should have no more than 0.5 in. (12.69 mm) slack.</li> <li>Carriage cross chain (2) should have no slack.</li> <li>Install level wind drive chain covers (paras. 13-14 and 13-15).</li> </ol>
48	•			Earth boring machine	<p>Check tension on horizontal and vertical drive chains as follows:</p> <ol style="list-style-type: none"> <li>Remove drive chain covers (para. 12-87).</li> <li>Horizontal drive chains (5) and vertical drive chains (4) should have no more than .125 in. (3.17 mm) slack.</li> <li>Install drive chain covers (para. 12-87).</li> </ol>
49	•			Rack thrust plates	<p>To check rack thrust plates and adjustments on leveling worms and clutch assembly, notify your supervisor.</p>

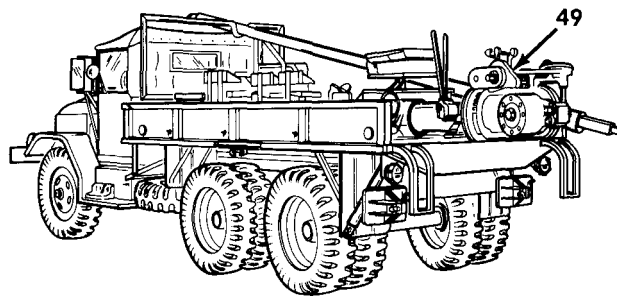

Table 2-1. Preventive Maintenance Checks and Services (Contd).

Item No.	Interval			Item to be Inspected	Procedures
	S	A	B		
50	•			Rifle mounting kit	<p>a. Check top mount and lower mount for looseness and damage. If loose, tighten. If damaged, replace (para. 14-44).</p> <p>b. Check handle for excessive looseness, binding, and damage.</p>
51	•			Machine gun mount	Perform preventive maintenance checks and services (TM 9-1005-245-14).
52				M-8 chemical alarm	Perform preventive maintenance checks and services (TM 3-6665-225-12).
53				M-11 decontamination unit	Perform preventive maintenance checks and services (TM 3-4230-204-12&P).
54				Vehicle lubrication	Lubricate vehicle (LO 9-2320-209-12-1).
					<b>FINAL ROAD TEST</b>
					After all services and inspections have been completed, take vehicle on a short road test to ensure all corrections have been implemented. Correct any defects or malfunctions that may occur during this test.

## Section IV. MECHANICAL SYSTEMS TROUBLESHOOTING

### 2-12. GENERAL

#### NOTE

If malfunction corrective action does not correct malfunction, notify your supervisor.

**a.** This section provides information to diagnose and correct malfunctions of mechanical systems. Because of its complexity, Mechanical Systems Troubleshooting is divided into the following functional systems:

- Engine (page 2-28)
- Exhaust System (page 2-32)
- Manifold Heater System (page 2-33)
- Cooling System (page 2-34)
- Fuel System (page 2-35)
- Personnel Hot Water Heater (page 2-35)
- Transmission (page 2-35)
- Clutch (page 2-36)
- Transfer Case (page 2-36)
- Propeller Shafts (page 2-37)
- Differentials (page 2-37)
- Wheels and Tires (page 2-38)
- Steering (page 2-39)
- Frame and Brackets (page 2-41)
- Suspension (page 2-42)
- Winch (page 2-42)
- Power Takeoff (page 2-43)
- Nonelectrical Gages (page 2-44)
- Fifth Wheel (page 2-45)
- Dump Body (M342A2) (page 2-45)
- Earth Boring and Polesetting (M764) (page 2-46)
- Outriggers (M764) (page 2-47)
- Fuel Tank (M49A2C) (page 2-47)
- Water Tank (M50A2 and M50A3) (page 2-49)
- Personnel Fuel Burning Heater/Power Plant Heater (page 2-50)

**b.** Each malfunction symptom given for an individual component or system is followed by step(s) to determine the cause and corrective action you must take to remedy the problem.

**c.** Before taking any action to correct a possible malfunction, the following rules should be followed:

- (1) Question operator to obtain any information that might help you to determine the cause of the problem.
- (2) Never overlook the chance that the problem could be of simple origin. The problem could be corrected with minor adjustment.
- (3) Use all senses to observe and locate troubles.
- (4) Use test instruments or gages to help you to determine and isolate problems.
- (5) Always isolate the system where the malfunction occurs and then locate the defective component.
- (6) Use standard automotive theories and principles when troubleshooting the vehicles covered in this manual.

**d.** Omissions. This manual cannot list all mechanical malfunctions that may occur. If a malfunction occurs that is not listed in table 2-2, notify your supervisor.

## MECHANICAL SYSTEMS TROUBLESHOOTING SYMPTOM INDEX

MALFUNCTION NO.	MALFUNCTION	TROUBLESHOOTING PROCEDURE PAGE
<b>ENGINE</b>		
1.	Engine will not crank . . . . .	2-28
2.	Engine cranks but will not start . . . . .	2-28
3.	Starter cranks engine slowly . . . . .	2-29
4.	Engine stops during normal operation . . . . .	2-29
5.	Engine stops when accelerator is returned to idle position . . . . .	2-30
6.	Engine misfires during operation . . . . .	2-30
7.	Poor acceleration and/or lack of power . . . . .	2-30
8.	Engine surges . . . . .	2-31
9.	Excessive engine oil loss or consumption during normal operation . . . . .	2-31
10.	Engine oil pressure too low or too high at normal operation temperature . . . . .	2-31
11.	Excessive vibration or clunking . . . . .	2-32
12.	Excessive fuel consumption . . . . .	2-32
<b>EXHAUST SYSTEM</b>		
13.	Exhaust color blue during normal operation . . . . .	2-32
14.	Exhaust color white during normal operation and idle . . . . .	2-32
15.	Excessive exhaust noise . . . . .	2-33
16.	Exhaust fumes in cab . . . . .	2-33
<b>MANIFOLD HEATER SYSTEM</b>		
17.	Engine cranks but will not start in cold weather (fuel system operating properly) . . . . .	2-33
<b>COOLING SYSTEM</b>		
18.	Engine temperature gage above 230°F (110°C). . . . .	2-34
19.	Engine does not reach normal operating temperature. . . . .	2-34
20.	Coolant loss during normal operation . . . . .	2-34
<b>FUEL SYSTEM</b>		
21.	No fuel at fuel injectors . . . . .	2-35
<b>PERSONNEL HOT WATER HEATER</b>		
22.	Personnel hot water heater does not heat cab . . . . .	2-35
<b>TRANSMISSION</b>		
23.	Transmission noisy . . . . .	2-35
24.	Transmission leaks oil . . . . .	2-36
<b>CLUTCH</b>		
25.	Clutch pedal will not travel or depress . . . . .	2-36
26.	Vehicle creeps with clutch depressed. . . . .	2-36
27.	Clutch drags, slips, or does not engage . . . . .	2-36

**MECHANICAL SYSTEMS TROUBLESHOOTING  
SYMPTOM INDEX (Contd)**

MALFUNCTION NO.	MALFUNCTION	TROUBLESHOOTING PROCEDURE PAGE
<b>TRANSFER CASE</b>		
28.	Burning odor evident with clutch engaged. . . . .	2-36
29.	Transfer case difficult to shift . . . . .	2-37
30.	Transfer case grinds or pops out of gear during normal vehicle operation . . . . .	2-37
31.	Transfer case noisy . . . . .	2-37
<b>PROPELLER SHAFTS</b>		
32.	Propeller shaft vibration . . . . .	2-37
<b>DIFFERENTIALS</b>		
33.	Differential noisy . . . . .	2-37
34.	Differential clunks during turns or initial takeoff. . . . .	2-38
35.	Differential vibrates . . . . .	2-38
36.	Differential leaks oil . . . . .	2-38
<b>WHEELS AND TIRES</b>		
37.	Uneven tire wear . . . . .	2-38
38.	Vehicle shimmy, wobble, or vibration. . . . .	2-39
<b>STEERING</b>		
39.	Excessive play in steering . . . . .	2-39
40.	Steering wheel hard to turn . . . . .	2-40
41.	Vehicle wanders or pulls to one side. . . . .	2-40
<b>FRAME AND BRACKETS</b>		
42.	Towing pintle does not latch or lock . . . . .	2-41
43.	Pintle hook does not turn . . . . .	2-41
44.	Excessively loose lifting shackle . . . . .	2-41
45.	Loose spare tire carrier . . . . .	2-41
<b>SUSPENSION</b>		
46.	Noisy suspension . . . . .	2-42
47.	Continuous wandering or swaying (poor control) . . . . .	2-42
48.	Vehicle sags . . . . .	2-42
<b>WINCH</b>		
49.	Winch inoperative . . . . .	2-42
50.	Winch operates in one direction only. . . . .	2-43
51.	Operates at one speed only . . . . .	2-43
52.	Drag brake does not operate . . . . .	2-43
53.	Winch does not hold load when power released . . . . .	2-43
54.	Automatic brake overheats . . . . .	2-43
55.	Vehicle rolls while operating rear winch . . . . .	2-43
<b>POWER TAKEOFF</b>		
56.	Power takeoff noisy . . . . .	2-43
57.	Power takeoff difficult to shift . . . . .	2-44
58.	(Transmission-driven) power takeoff inoperative . . . . .	2-44
59.	(Transfer-driven) power takeoff inoperative. . . . .	2-44

**MECHANICAL SYSTEMS TROUBLESHOOTING  
SYMPTOM INDEX (Contd)**

MALFUNCTION No.	MALFUNCTION	TROUBLESHOOTING PROCEDURE PAGE
<b>NON ELECTRICAL GAGES</b>		
60.	Speedometer or tachometer bounces, noisy, or inoperative. . . . .	2-44
61.	Air pressure gage inoperative . . . . .	2-44
<b>FIFTH WHEEL</b>		
62.	Trailer will not hitch to fifth wheel. . . . .	2-45
<b>DUMP BODY (M342A2)</b>		
63.	Dump body will not raise . . . . .	2-45
64.	Dump body does not lower . . . . .	2-45
65.	Dump body does not hold in raised position . . . . .	2-45
66.	Hydraulic pump noisy . . . . .	2-46
67.	Tailgate does not open . . . . .	2-46
<b>EARTH BORING AND POLESETTING (M764)</b>		
68.	Earth boring machine will not operate . . . . .	2-46
69.	Earth boring machine cannot be moved vertically . . . . .	2-46
70.	Earth boring machine cannot be moved horizontally. . . . .	2-46
<b>OUTRIGGERS (M764)</b>		
71.	Outriggers inoperative . . . . .	2-47
72.	Outriggers operate slowly . . . . .	2-47
<b>FUEL TANK (M49A2C)</b>		
73.	Fuel does not pump from compartments, or pumps slowly. . . . .	2-47
74.	Delivery pump dispenses fuel slowly from both tanks. . . . .	2-47
75.	Fuel does not pump or pumps fuel slowly from selected tank, and fuel drains slowly from selected tank using gravity procedures . . .	2-48
76.	Fuel tank compartments cannot be suction filled . . . . .	2-48
<b>WATER TANK (M50A2 AND M50A3)</b>		
77.	Water cannot be pumped from both tanks . . . . .	2-49
78.	Water cannot be pumped or pumps slowly from selected tank, and water drains slowly from selected tank using gravity procedures. .	2-49
79.	Water pumps out of both tanks slower than normal . . . . .	2-49
80.	Water tank compartments cannot be suction filled . . . . .	2-50
<b>PERSONNEL FUEL BURNING HEATER/POWER PLANT HEATER KIT</b>		
81.	Heater will not operate in high or low position. . . . .	2-50
82.	Heater will not operate . . . . .	2-50



Table 2-2. Mechanical Troubleshooting.

MALFUNCTION	TEST OR INSPECTION	CORRECTIVE ACTION
-------------	--------------------	-------------------

**ENGINE**

**1. ENGINE WILL NOT CRANK**

- Step 1. Check starting system (table 2-4, electrical troubleshooting, malfunction 2).
- Step 2. Remove starter and visually check starter drive, ring gear, and flywheel for broken and missing teeth.
  - a. If starter teeth are damaged, replace starter (para. 4-7).
  - b. If ring gear is damaged, notify your supervisor.

**WARNING**

Ensure fuel shutoff valve is OFF and remove throttle cable before cranking engine. Failure to do so may result in injury to personnel.

- Step 3. Check for seized engine or fluid-locked pistons. Remove radiator and rotate engine at vibration damper bolt two full revolutions with starter removed.  
If engine is seized, notify your supervisor.
- Step 4. Check belt-driven engine accessories and water pump for seizure. Remove all belts (para. 4-2 and 8-28).  
Manually turn drive pulley of each accessory and water pump.
  - a. If water pump drive pulley will not turn, replace water pump (para. 3-47).
  - b. If any drive pulley accessory will not turn, replace accessory (paras. 3-47, 4-3, and 8-26).  
If fuel pump needs replacement, notify your supervisor.
- Step 5. Check air induction system for presence of water.  
Remove air cleaner cover (para. 3-14).
  - a. If air cleaner cover is contaminated with water, replace element (para. 3-14).
  - b. If water is present within air cleaner, notify your supervisor.
- Step 6. Check vertical exhaust system and turbocharger for presence of water. Remove exhaust elbow from turbocharger (para. 3-37).
  - a. If water is present in exhaust elbow, disassemble and drain exhaust system (para. 3-37).
  - b. If water is present in turbocharger housing, identified by water on turbocharger fins or hub, notify your supervisor.

END OF TESTING!

**2. ENGINE CRANKS BUT WILL NOT START**

- Step 1. Refer to table 2-4, electrical troubleshooting, malfunction 3.
- Step 2. Check air cleaner indicator (TM 9-2320-361-10).
  - a. If red appears at indicator window, inspect air intake head for restrictions. If restrictions are not present, replace air cleaner element (para. 3-14).
  - b. Reset air cleaner indicator (TM 9-2320-361-10).

**WARNING**

- Diesel fuel is flammable. Do not perform fuel system procedures near open flame. Injury or death to personnel may result.
- Compressed air source will not exceed 30 psi (207 kPa). When cleaning with compressed air, eyeshields must be worn. Failure to wear eyeshields may result in injury to personnel.

Table 2-2. Mechanical Troubleshooting (Contd)

MALFUNCTION	TEST OR INSPECTION	CORRECTIVE ACTION
-------------	--------------------	-------------------

- Step 3. Turn accessory switch to ON position and drain 1/2 pint (0.25 liter) of fuel from primary fuel filter, secondary fuel filter, and final fuel filter. Check for contaminated fuel.  
If water or contamination are present, remove fuel tank (chapter 3, section VI). Clean and flush entire fuel system. Dry system with compressed air.
- Step 4. Check for white exhaust smoke during cranking.
- If white smoke can be seen, air maybe in fuel system. Bleed fuel system (para. 3-29).
  - If white smoke can be seen, coolant maybe inside combustion chambers. If coolant is present on dipstick, notify your supervisor.
- Step 5. Check in-tank pump pressure (para. 3-26). If pressure is below 4 psi (27.58 kPa), replace in-tank fuel pump (para. 3-26).
- Step 6. Turn accessory switch to ON position and check pressure at secondary and final fuel filters (para. 3-29).
- If pressure is below 2 psi (14.00 kPa), remove and replace primary fuel filter (para. 3-28) and recheck pressure at secondary and final fuel filters. If pressure is still below 2 psi (14.00 kPa), replace secondary and final fuel filters (para. 3-29).
  - If filters are clean and pressure is still below 2 psi (14.00 kPa) at secondary and final fuel filter, inspect fuel lines for kinks, bends, breaks, loose connections, restrictions, and leaks. Repair fuel lines if damaged.

END OF TESTING!

### 3. STARTER CRANKS ENGINE SLOWLY

- Step 1. Check starting system circuits (table 2-4, malfunction 3).
- Step 2. In cold weather, make sure proper engine oil is being used and /or replace oil (LO 9-2320-209-12-1).
- Step 3. Check water pump and belt driven accessories for seizing (malfunction 1, step 4).

END OF TESTING!

### 4. ENGINE STOPS DURING NORMAL OPERATION

- Step 1. Check air cleaner for restrictions (malfunction 2, step 2).
- Step 2. Check fuel system for contamination and restrictions (malfunction 2, step 3 and malfunction 21).
- Step 3. Check for restrictions in exhaust system. Ensure exhaust is not bent, restricted, or damaged.  
If exhaust system is damaged or restricted, replace damaged parts (para. 3-37).
- Step 4. Check air induction system for major restrictions.  
If air induction system is restricted, clean or replace defective components (Chapter 3, section IV).
- Step 5. Check governor idle speed (para. 8-29).  
If governor idle speed is set below specifications, adjust (para. 8-29).

END OF TESTING!

Table 2-2. Mechanical Troubleshooting (Contd).

MALFUNCTION	TEST OR INSPECTION	CORRECTIVE ACTION
-------------	--------------------	-------------------

**5. ENGINE STOPS WHEN ACCELERATOR IS RETURNED TO IDLE POSITION**

- Step 1. Check air induction system for restrictions.  
If air induction system is restricted, clean or replace defective components (Chapter 3, section IV).
- Step 2. Check governor idle speed (para. 8-29).  
If governor idle speed is set below specifications, adjust (para. 8-29).
- Step 3. Perform malfunction 27.

END OF TESTING!

**6. ENGINE MISFIRES DURING OPERATION**

- Step 1. Check air cleaner for restrictions (malfunction 2, step 2).
- Step 2. Check for air or water in fuel system (malfunction 2, steps 3 and 4).

END OF TESTING!

**7. POOR ACCELERATION AND/OR LACK OF POWER**

- Step 1. Check air cleaner for restrictions (malfunction 2, step 2).
- Step 2. Check air induction system for restrictions. If air induction system is restricted, clean or replace defective components (Chapter 3, section IV).
- Step 3. Check fuel system for contamination and restrictions (malfunction 2, steps 3 and 4).
- Step 4. Check exhaust system for restrictions.  
Replace restricted or damaged parts (para. 3-37).
- Step 5. Inspect accelerator pedal and throttle lever for full travel.  
Adjust throttle lever travel (para. 3-33).
- Step 6. Check vehicle for dragging brakes, low tire inflation, or cargo overload limit (TM 9-2320-361-10).
  - a. If defects are evident during check, adjust or replace components (para. 8-8 or TM 9-2320-361-10).
  - b. Correct overload condition (TM 9-2320-361-10).
- Step 7. Check throttle linkage for binding and sticking.  
If linkage is binding or sticking, replace throttle linkage (para. 3-33).
- Step 8. Check maximum engine governed speed set within specifications (para. 8-29). If maximum engine governed speed setting is incorrect, adjust (para. 8-29). Perform malfunction 27.
- Step 9. Check turbocharger hoses and intake manifold elbow for leaks.
  - a. Tighten base screws and clamps. Replace any missing screws or clamps (para. 3-13).
  - b. If no improvement during test run, turbocharger malfunction is indicated; notify your supervisor.

END OF TESTING!

Table 2-2. Mechanical Troubleshooting (Contd).

MALFUNCTION	TEST OR INSPECTION	CORRECTIVE ACTION
-------------	--------------------	-------------------

**8. ENGINE SURGES**

- Step 1. Check fuel system for contamination and restrictions.  
Refer to malfunction 2, steps 3 and 4.
- Step 2. Inspect throttle linkage for proper operation and adjustment  
If linkage does not operate properly, adjust or replace as necessary (para. 3-33).
- Step 3. Check in-tank fuel pump operation (para. 3-26).  
If fuel pressure is uneven or below specifications, replace (para. 3-26).  
END OF TESTING!

**9. EXCESSIVE OIL LOSS OR CONSUMPTION DURING NORMAL OPERATION**

- Step 1. Check oil for overfilling. Check oil level (TM 9-2320-361-10).  
If oil level is too high, drain crankcase to safe operating level (LO 9-2320-209-12-1).
- Step 2. Check for external oil leaks at oil pan, drainplug, oil filter, oil filter housing, oil cooler, oil dipstick tube, rocker arm cover, and oil feed lines.  
Tighten any loose connections or loose screws that may cause leaks.
- Step 3. Check maximum engine governed speed set within specifications (para. 8-29).  
If maximum engine governed speed is incorrect, adjust (para. 8-29).
- Step 4. Complete troubleshooting malfunction 10, step 4.
- Step 5. If oil leaks still exist, or engine still burns oil, notify your supervisor.  
END OF TESTING!

**10. ENGINE OIL PRESSURE TOO LOW OR TOO HIGH AT NORMAL OPERATION TEMPERATURE****CAUTION**

Do not operate engine except during testing. When condition of no oil pressure is evident, continued operations may damage engine internally.

- Step 1. Check engine oil level (LO 9-2320-209-12-1).  
If level is low, check for external oil leaks at oil pan, drainplug, oil filter, oil filter housing, oil cooler, oil dipstick tube, and rocker arm cover.  
Tighten any loose connections or loose screws that may cause leaks.
- Step 2. Check engine for excessive engine operating temperature (TM 9-2320-361-10).
- Step 3. Check that engine oil grade is correct for vehicle use and climate conditions (LO 9-2320-209-12-1).  
If engine oil grade is incorrect, replace oil (LO 9-2320-209-12-1).
- Step 4. Check oil pressure gage for proper operation.
- Check operation of oil pressure gage (table 2-4, malfunction 32).
  - Check oil pressure. Oil pressure should be 40-75 psi at 2,600 rpm.  
If oil pressure gage has a maximum reading of 60 psi and needle peaks at 60 psi, replace with new oil pressure gage (range 0-120 psi) (para. 4-12).
  - If oil pressure is still too high or too low, notify your supervisor.
- Step 5. Check all external oil fuel lines for leakage or restrictions. Clear restrictions or repair leaks.

END OF TESTING!

Table 2-2. Mechanical Troubleshooting (Contd).

MALFUNCTION	TEST OR INSPECTION	CORRECTIVE ACTION
-------------	--------------------	-------------------

**11. EXCESSIVE VIBRATION OR CLUNKING**

Check engine mounts and pads for looseness or damage.

If engine mounts or pads are damaged, replace (paras. 3-2 and 3-3).

END OF TESTING!

**12. EXCESSIVE FUEL CONSUMPTION**

Step 1. Check for air cleaner restrictions (malfunction 2, step 2).

Step 2. Inspect fuel lines, hoses, and connections for leaks and damage.

a. Tighten any loose connections.

b. If fuel lines, hoses, or connections are leaking or damaged, notify your supervisor.

END OF TESTING!

**EXHAUST SYSTEM**

**13. EXHAUST COLOR BLUE DURING NORMAL OPERATION**

**NOTE**

Blue exhaust indicates presence of excess engine oil in cylinder combustion space.

Step 1. Check that engine oil grade is correct for vehicle use and climatic conditions (LO 9-2320-209-12-1).

If oil grade is incorrect, replace oil (LO 9-2320-209-12-1) and oil filters (para. 3-8).

Step 2. Check that engine fuel grade is correct for vehicle use and climatic conditions (TM 9-2320-361-10).

a. If fuel grade is incorrect, drain complete fuel system and replace with correct grade of fuel (TM 9-2320-361-10).

b. If problem persists, notify your supervisor.

END OF TESTING!

**14. EXHAUST COLOR WHITE DURING NORMAL OPERATION AND IDLE**

**CAUTION**

Thick white smoke indicates coolant is present in engine combustion chambers during operation. When this condition is evident, shut engine down immediately and determine cause. Continued engine operations may result in permanent engine damage.

Step 1. Check engine temperature. Ensure engine temperature is at specified level (TM 9-2320-361-10).

If engine temperature is above operating level, perform malfunction 18.

Step 2. If problem persists, notify your supervisor.

END OF TESTING!

Table 2-2. Mechanical Troubleshooting (Contd).

MALFUNCTION	TEST OR INSPECTION	CORRECTIVE ACTION
-------------	--------------------	-------------------

**15. EXCESSIVE EXHAUST NOISE**

- Step 1. Inspect turbocharger for secure mounting and exhaust leaks.  
If turbocharger mountings are loose, tighten 23-27 lb-ft (31-37 N·m).
- Step 2. Inspect exhaust pipes for secure connections, cracks, breaks, and excessive rust. Replace damaged parts (chapter 3, section VIII).
- Step 3. Inspect exhaust stack for secure connections, cracks, and breaks. Replace damaged parts (chapter 3, section VIII).
- Step 4. If excessive exhaust noise still exists, it may be necessary to install exhaust insulator kit 12300664.

END OF TESTING!

**16. EXHAUST FUMES IN CAB**

- Step 1. Inspect exhaust manifold, turbocharger, exhaust pipes, and connections for leaks.  
Replace damaged parts (chapter 3, section VIII).
- Step 2. Inspect exhaust manifold and turbocharger for leaks. If leaking, notify your supervisor.

END OF TESTING!

**MANIFOLD HEATER SYSTEM****17. ENGINE CRANKS BUT WILL NOT START IN COLD WEATHER (FUEL SYSTEM OPERATING PROPERLY)**

- Step 1. Check manifold heater system electrical circuit (table 2-4, malfunction 39).
- Step 2. Check fuel pump supply lines and filter for leaks, bends, kinks, and restrictions. If vehicle is equipped with alcohol evaporator, check for proper operation as required (TM 9-2320-361-10).

**WARNING**

Diesel fuel is flammable. Do not perform fuel system procedures near open flame. Injury or death to personnel may result.

**NOTE**

- Have drainage container ready to catch fuel.
- During steps 3 and 4, do not confuse in-tank fuel pump pressure with manifold heater pump pressure.

- Step 3. Disconnect fuel line at fuel nozzle, energize manifold heater circuit and check to see if fuel is discharged.

If fuel is not discharged, replace manifold heater fuel pump (para. 3-30 or 3-31).

- Step 4. Check fuel nozzle for proper operation. Remove fuel return lines (para. 3-27). Energize circuit and check to see if fuel is discharged. If fuel is not discharged, notify your supervisor.

END OF TESTING!

Table 2-2. Mechanical Troubleshooting (Contd).

MALFUNCTION	TEST OR INSPECTION	CORRECTIVE ACTION
-------------	--------------------	-------------------

**COOLING SYSTEM**

**18. ENGINE TEMPERATURE GAGE ABOVE 230°F (110°C)**

**WARNING**

Use caution when removing radiator filler cap. Steam or hot coolant under pressure may cause injury to personnel.

- Step 1. Ensure engine fuel supply grade is correct for vehicle use and climatic conditions (TM 9-2320-361-10).  
If fuel grade is incorrect, completely drain fuel system and replace fuel with correct grade (TM 9-2320-361-10).
- Step 2. Check coolant protection level with antifreeze tester.  
If coolant is not within safe range, service cooling system (para. 3-41).
- Step 3. Check engine temperature gage and engine temperature sending unit (table 2-4, malfunction 30).  
If engine temperature gage is defective, replace (para. 4-12).  
If engine temperature sending unit is defective, replace (para. 4-24).
- Step 4. Inspect drivebelts and pulleys for damage and check belt tension. Replace any damaged parts and adjust drivebelts (para. 4-2).
- Step 5. Inspect fan for broken or missing blades.  
If blades are broken or missing, replace fan (para. 3-40).
- Step 6. Inspect radiator for bent fins.  
Straighten bent fins, or replace radiator (para. 3-42).
- Step 7. Start engine. Remove radiator cap and visually check coolant for proper circulation. Stop engine if coolant is not circulating properly, remove thermostat, and test or replace (para. 3-46).
- Step 8. Check for clogged or broken radiator (TM 750-254). For cleaning and flushing instructions refer to TB 750-651.
- Step 9. Check operation of temperature gage (table 2-4, malfunction 30).

END OF TESTING!

**19. ENGINE DOES NOT REACH NORMAL OPERATING TEMPERATURE**

- Step 1. Start engine. Remove radiator cap and visually check coolant for proper circulation. Stop engine. If coolant is circulating below 100°F, remove thermostat and test or replace (para. 3-46).
- Step 2. Test coolant temperature gage, sending unit, and electrical circuits (table 2-4, malfunction 30).

END OF TESTING!

**20. COOLANT LOSS DURING NORMAL OPERATION**

- Step 1. Pressurize cooling system and check for leaks.
  - a. Tighten loose clamps, fasteners, or fittings.
  - b. Replace leaking hoses and/or water pump (para. 3-43 or 3-47).
- Step 2. Check radiator cap for proper relief pressure (TM 750-254). Relief pressure should be 15 psi (103 kPa). Replace radiator cap if defective.
- Step 3. Check for coolant in oil.  
If coolant is found in oil, notify your supervisor.

END OF TESTING!

Table 2-2. Mechanical Troubleshooting (Contd).

MALFUNCTION	TEST OR INSPECTION	CORRECTIVE ACTION
-------------	--------------------	-------------------

**FUEL SYSTEM****WARNING**

- Diesel fuel is flammable. Do not perform troubleshooting checks near open flame, sparks, or electricity. Injury to personnel may result.
- Eye protection is required when performing fuel system troubleshooting checks. Failure to wear eye protection may result in injury to personnel.
- Ignition switch must remain OFF during fuel system troubleshooting checks. Failure to verify that ignition system is turned off may result in injury to personnel.

**21. NO FUEL AT FUEL INJECTORS**

Step 1. Check final fuel filter for restrictions (para. 3-29).

- If final fuel filters are restricted or defective, replace (para. 3-29).
- If final fuel filters are not restricted and problem persists, notify your supervisor.

END OF TESTING!

**PERSONNEL HOT WATER HEATER****22. PERSONNEL HOT WATER HEATER DOES NOT HEAT CAB**

Step 1. Engine does not reach normal operating temperature.

Refer to malfunction 19.

Step 2. Check personnel hot water heater for clogged, broken, or leaking inlet/outlet hoses.

If personnel hot water heater hoses are leaking or collapsed, replace (para. 3-44).

Step 3. Check for proper personnel hot water heater control cable operation of heater, defroster, and heater diverter vents and doors.

If control cables are bent or broken, replace (para. 11-41).

Step 4. Check heater blower motor and fan for proper operation (TM 9-2320-361-10).

If damaged, replace personnel hot water heater (para. 11-42).

END OF TESTING!

**TRANSMISSION****23. TRANSMISSION NOISY**

Step 1. Check propeller shafts condition. Remove propeller shafts and inspect (para. 7-2).

If propeller shafts assemblies are worn or defective, repair or replace (para. 7-2).

Step 2. Check clutch for proper adjustment.

Adjust clutch linkage as necessary (para. 3-10).

Step 3. Check transmission fluid level (LO 9-2320-209-12-1).

Step 4. Drain transmission fluid and check for signs of broken gears, metal shavings, and contamination (LO 9-2320-209-12-1).

If broken gears or metal shavings are found, notify your supervisor.

END OF TESTING!



Table 2-2. Mechanical Troubleshooting (Contd).

MALFUNCTION	TEST OR INSPECTION	CORRECTIVE ACTION
-------------	--------------------	-------------------

**24. TRANSMISSION LEAKS OIL**

- Step 1. Check transmission fluid level (LO 9-2320-209-12-1). If fluid level is too high, drain to proper level (LO 9-2320-209-12-1).
- Step 2. Check drainplug for leaks.  
If drainplug is leaking, tighten.
- Step 3. Check breather for restrictions.  
If breather is restricted, refer to para. 5-2.

END OF TESTING!

**25. CLUTCH PEDAL WILL NOT TRAVEL OR DEPRESS**

- Step 1. Check transmission fluid level (LO 9-2320-209-12-1).  
If fluid level is low, add fluid (LO 9-2320-209-12-1).
- Step 2. Check clutch linkage to ensure it is connected and properly adjusted (para. 3-10).

END OF TESTING!

**CLUTCH**

**26. VEHICLE CREEPS WITH CLUTCH DEPRESSED**

- Step 1. Check clutch pedal free travel. Clutch pedal should have 1.5 - 2 in. (3.8 - 5 cm) free travel.  
If clutch requires adjustment, refer to para. 3-10.
- Step 2. If free travel will not adjust, notify your supervisor.

END OF TESTING!

**27. CLUTCH DRAGS, SLIPS, OR DOES NOT ENGAGE**

- Step 1. Check clutch linkage for binding.  
If linkage binds, check for bent or broken parts. Replace damaged parts (para. 3-10).
- Step 2. Check linkage for proper lubrication (LO 9-2320-209-12-1).
- Step 3. Check clutch linkage for proper adjustment.  
Adjust clutch linkage as necessary (para. 3-10).
- Step 4. Inspect torque rods.
  - a. Place flat end of crowbar or pinch bar between torque rod and mounting bracket.
  - b. Push on end of bar until hook end moves 4-6 in. (10.2-15.2 cm).
  - c. Release pressure on bar.  
If torque rod does not return to original position, replace (para. 7-22).
- Step 5. Check clutch for proper adjustment.  
If clutch is not adjusted properly, notify your supervisor.

END OF TESTING!

**TRANSFER CASE**

**28. BURNING ODOR EVIDENT WITH CLUTCH ENGAGED**

- Check clutch linkage and adjustment (para. 3-10).
  - a. If clutch is not adjusted correctly, adjust (para. 3-10).
  - b. If problem persists, notify your supervisor.

END OF TESTING!

Table 2-2. Mechanical Troubleshooting (Contd).

MALFUNCTION	TEST OR INSPECTION	CORRECTIVE ACTION
-------------	--------------------	-------------------

**29. TRANSFER CASE DIFFICULT TO SHIFT**

- Step 1. Check transfer case fluid level (LO 9-2320-209-12-1).  
Fill or drain to proper level (LO 9-2320-209-12-1).
- Step 2. Inspect shift linkage for bends, breaks, or missing parts.  
Replace any broken, bent, or missing parts (para. 6-2 or 6-3).
- Step 3. If internal problems in transfer case exist, notify your supervisor.

END OF TESTING!

**30. TRANSFER CASE GRINDS OR POPS OUT OF GEAR DURING NORMAL VEHICLE OPERATION**

- Step 1. Check condition and adjustment of external transfer case linkages. If linkages are damaged, repair, replace, or adjust (para. 6-2 or 6-3).
- Step 2. If internal problems in transfer case exist, notify your supervisor.

END OF TESTING!

**31. TRANSFER CASE NOISY**

- Step 1. Check transfer case fluid level (LO 9-2320-209-12-1).  
If low, fill to proper level (LO 9-2320-209-12-1).
- Step 2. Drain transfer case fluid (LO 9-2320-209-12-1) and check for signs of broken gears, metal shavings and contamination.  
If broken gears, metal shavings, or contamination are found in transfer case or on magnetic drainplug, notify your supervisor.

END OF TESTING!

**PROPELLER SHAFTS****32. PROPELLER SHAFT VIBRATION**

- Step 1. Inspect propeller shaft for foreign material or damage.  
Clean foreign material from propeller shaft, or replace if damaged (para. 7-2).
- Step 2. Inspect propeller shaft for loose screws.  
If any screws are loose, tighten.
- Step 3. Check universal joints for play or looseness.  
If rust is visible around U-joint, disassemble and inspect.  
Replace U-joint, disassemble and inspect. Replace U-joint if damaged (para. 7-4).

END OF TESTING!

**DIFFERENTIALS****33. DIFFERENTIAL NOISY**

- Step 1. Check to see if front wheel drive is engaged.  
Disengage front wheel drive when traveling on hard flat surfaces.
- Step 2. Check lubrication level in axle housing differential (LO 9-2320-209-12-1). If low, fill to proper oil level (LO 9-2320-209-12-1).
- Step 3. Check for loose inner wheel adapter nuts or loose lugnuts.
  - a. If inner wheel adapter nuts are loose, tighten 400-425 lb-ft (542-576 N·m).
  - b. If lugnuts are loose, tighten 325-355 lb-ft (441-481 N·m).

Table 2-2. Mechanical Troubleshooting (Contd).

MALFUNCTION	TEST OR INSPECTION	CORRECTIVE ACTION
-------------	--------------------	-------------------

Step 4. Check for loose or damaged wheel bearings. Raise wheel off ground. Use prybar to check for excessive play.

- a. Adjust wheel bearings (para. 9-5).
- b. If damaged, replace wheel bearings (para. 9-3 or 9-4).

Step 5. Check differential operation. Remove differential propeller shaft(s) (para. 7-2). Raise wheels (TM 9-2320-361-10) and manually turn wheels and observe differential operation.

- a. If tires will not rotate, check brakeshoe condition and operation (para. 8-7).
- b. Remove brakedrums (para. 8-2). If brake system components are defective, repair or replace (paras. 8-7 through 8-16, as necessary, or notify your supervisor).
- c. If tires still will not rotate, notify your supervisor.
- d. If tire rotation drags at some points during full rotation, remove and inspect axle shafts (para. 7-6 or 7-10).
- e. If axle shafts are defective, replace (para. 7-6 or 7-10).

END OF TESTING!

**34. DIFFERENTIAL CLUNKS DURING TURNS OR INITIAL TAKE OFF**

Step 1. Check differential propeller shaft(s) and universal joint(s) condition (para. 7-2).

Repair or replace defective components (para. 7-2).

Step 2. Check front axle shafts and universal joints for defects (para. 7-6).

Repair or replace defective components (para. 7-6).

Step 3. If internal problems in differential exist, notify your supervisor.

END OF TESTING!

**35. DIFFERENTIAL VIBRATES**

Step 1. Check tires and rims condition. Repair or replace defective components (para. 9-2).

Step 2. Complete troubleshooting malfunction 34, steps 1 and 2.

Step 3. If internal problems in differential exist, notify your supervisor.

END OF TESTING!

**36. DIFFERENTIAL LEAKS OIL**

Check axle seals condition. Inspect drum for presence of gear oil.

If gear oil is present in or around drums, replace axle seals (para. 7-7).

END OF TESTING!

**WHEEL AND TIRES**

**37. UNEVEN TIRE WEAR**

Step 1. Check vehicle for overload (TM 9-2320-361-10). If vehicle load is excessive, adjust to capacity limit.

Step 2. Check for loose inner wheel adapter nuts or loose lugnuts (malfunction 33, step 3).

- a. If inner wheel adapter nuts are loose, tighten 400-425 lb-ft (542-576 N.m).
- b. If lugnuts are loose, tighten 325-355 lb-ft (441-481 N.m).

Table 2-2. Mechanical Troubleshooting (Contd).

MALFUNCTION	TEST OR INSPECTION	CORRECTIVE ACTION
-------------	--------------------	-------------------

- Step 3. Check for correct tire pressure (TM 9-2320-361-10).  
Adjust tire pressure if necessary (TM 9-2320-361-10).
- Step 4. Check shock absorbers for class II or class III leakages.  
Replace any defective shocks (para. 7-20).
- Step 5. Check for improper toe-in adjustment.  
If tire problem is on front wheels, adjust toe-in (para. 9-7).
- Step 6. Check wheel bearings for proper adjustment and damage. Raise wheel off ground. Use prybar to check for excessive play.  
a. Adjust wheel bearings (para. 9-5).  
b. If damaged, replace wheel bearings (para. 9-3 or para. 9-4).
- Step 7. Check drag link for defects (para. 9-11).  
a. If linkage parts are defective, replace (para. 9-11).  
b. Perform steering gear adjustment (para. 9-9).
- Step 8. Check to make sure tires have been properly rotated (TM 9-2610-200-14 and TM 9-2610-201-14) for specific instructions.

END OF TESTING!

### 38. VEHICLE SHIMMY, WOBBLE, OR VIBRATION

- Step 1. Check for loose inner wheel adapter nuts or loose lugnuts (malfunction 33, step 3).
- Step 2. Check for dirt or mud buildup on wheel.  
Clean dirt and mud from wheel.
- Step 3. Inspect wheels for bends and damage.  
If bent or damaged, replace wheel (para. 9-2).
- Step 4. Inspect wheel bearings for proper adjustment and damage. Raise wheel off ground. Use prybar to check for excessive play.  
a. Adjust wheel bearings (para. 9-5).  
b. If damaged, replace wheel bearings (para. 9-3).
- Step 5. Inspect steering knuckles for loose conditions.  
If steering knuckles are loose and/or damaged, notify your supervisor.
- Step 6. Perform malfunction 37, step 7.

END OF TESTING!

### STEERING

#### 39. EXCESSIVE PLAY IN STEERING

- Step 1. Check for correct tire pressure (TM 9-2320-361-10).  
Adjust tire pressure, if necessary.
- Step 2. Check steering gear for secure mounting.  
If loose, tighten mounting screws 62-68 lb-ft (84-92 N·m).

Table 2-2. Mechanical Troubleshooting (Contd).

MALFUNCTION	TEST OR INSPECTION	CORRECTIVE ACTION
-------------	--------------------	-------------------

- Step 3. Inspect pitman arm, drag link, steering arm, steering knuckles, and tie-rod ends for looseness or damage.
  - a. Replace loose or damaged parts (paras. 9-8, 9-9, 9-10, and 9-11). If steering arm or knuckle is damaged, notify your supervisor.
  - b. Reset correct toe-in (para. 9-7).
- Step 4. Inspect wheel bearings for proper adjustment and damage (malfunction 38, step 4). Raise wheel off ground. Use prybar to check for excessive play.
  - a. Adjust wheel bearings (para. 9-5).
  - b. If damaged, replace wheel bearings (para. 9-3).
- Step 5. To adjust steering gear, refer to para. 9-9.  
If play in steering continues, notify your supervisor.

END OF TESTING!

**40. STEERING WHEEL HARD TO TURN**

- Step 1. Inspect pitman arm, drag link, steering, and tie-rod ends for binding, damage, or lack of lubrication.
  - a. If bent or damaged, replace (paras. 9-8, 9-9, 9-10, and 9-11). If steering arm is damaged, notify your supervisor.
  - b. If binding, lubricate (LO 9-2320-209-12-1).
- Step 2. Inspect steering knuckles for binding. Raise front wheels off ground. Disconnect drag link at pitman arm (paras. 9-8 and 9-11). Turn wheels to determine binding. If steering knuckles are binding, notify your supervisor.
- Step 3. Inspect springs for looseness.  
If loose, tighten U-bolts 190-230 lb-ft (258-312 N·m).
- Step 4. Check front tires for proper inflation.  
Adjust tire pressure as necessary (TM 9-2320-361-10).
- Step 5. Check for improper toe-in adjustment.  
Adjust toe-in if necessary (para. 9-7).

END OF TESTING!

**41. VEHICLE WANDERS OR PULLS TO ONE SIDE**

- Step 1. Check front tires for proper inflation.  
Adjust tire pressure as necessary (TM 9-2320-361-10).
- Step 2. Check front tires for uneven tire wear. If tire wear is evident, check toe-in.  
Adjust toe-in if necessary (para. 9-7).
- Step 3. Check for dragging brakes. Raise front wheels off ground. Spin wheels by hand, wheels should turn with slight drag when properly adjusted.  
If brakes require adjustment, refer to para. 8-8.
- Step 4. Check wheel bearings for proper adjustment and damage (malfunction 38). Raise wheel off ground. Use pry bar to check for excessive play.
  - a. Adjust wheel bearings (para. 9-5).
  - b. If damaged, replace wheel bearings (para. 9-3 or 9-4).
- Step 5. Check steering gear for loose mounting screws.  
If mounting screws are loose, tighten 62-68 lb-ft (84-92 N·m).

Table 2-2. Mechanical Troubleshooting (Contd).

MALFUNCTION	TEST OR INSPECTION	CORRECTIVE ACTION
-------------	--------------------	-------------------

Step 6. Inspect pitman arm, drag link, steering arm, and tie-rod ends for looseness or damage.

a. Replace loose or damaged parts, and reset correct toe-in (paras. 9-7, 9-8, 9-9, 9-10, and 9-11).

b. If steering arm is damaged, notify your supervisor.

Step 7. Inspect steering knuckles for binding or looseness (malfunction 40, step 2).

If binding or looseness is found, notify your supervisor.

Step 8. Inspect front springs and shackles for looseness.

Replace worn shackles (para. 7-13) or tighten loose spring U-bolts 190-230 lb-ft (258-312 N·m).

END OF TESTING!

#### FRAME AND BRACKETS

##### 42. TOWING PINTLE DOES NOT LATCH OR LOCK

Step 1. Inspect pintle hook for lubrication.

Lubricate pintle hook as required (LO 9-2320-209-12-1).

Step 2. Check pintle hook for proper operation.

If pintle hook is broken, bent, or parts are missing, disassemble and repair or replace (para. 10-4).

END OF TESTING!

##### 43. PINTLE HOOK DOES NOT TURN

Step 1. Check pintle hook for lubrication.

Lubricate pintle hook as required (LO 9-2320-209-12-1).

Step 2. Inspect pintle hook for bends.

If pintle hook is bent, replace (para. 10-4).

END OF TESTING!

##### 44. EXCESSIVELY LOOSE LIFTING SHACKLE

Inspect shackle pin for breaks, cracks, and bends.

If shackle pin is broken, cracked, or bent, replace (para. 10-2, 10-3, or 10-5).

END OF TESTING!

##### 45. LOOSE SPARE TIRE CARRIER

Step 1. Check for missing or broken mounting screws.

If mounting screws are broken or missing, replace (para. 10-7 or 12-16).

Step 2. Check spare tire carrier for bent, broken, or missing crank, crank gear, shaft, or bracket. If any spare tire carrier part is damaged, replace (para. 10-7 or 12-16).

END OF TESTING!

Table 2-2. Mechanical Troubleshooting (Contd).

MALFUNCTION	TEST OR INSPECTION	CORRECTIVE ACTION
-------------	--------------------	-------------------

**SUSPENSION**

**46. NOISY SUSPENSION**

- Step 1. Inspect leaf springs for damage.  
If damaged, replace (para. 7-12 or 7-16).
- Step 2. Check front spring shackles and steering linkage for lack of lubrication. If lubrication is required, refer to LO 9-2320-209-12-1.
- Step 3. Check rear spring seat pads for wear.  
If springs are rubbing against spring seat bracket, replace spring seat pads (para. 7-21).

END OF TESTING!

**47. CONTINUOUS WANDERING OR SWAYING (POOR CONTROL)**

- Step 1. Inspect front leaf springs for breaks.  
Replace any broken spring leafs (para. 7-13).
- Step 2. Inspect shock absorbers for class II or class III leaks and damage.  
Replace broken or leaking shocks (para. 7-20).
- Step 3. Inspect spring U-bolts for looseness or damage.
  - a. If U-bolts are loose, tighten 190-230 lb-ft (260-312 N-m).
  - b. If U-bolts are damaged, replace (para. 7-12).
- Step 4. Check steering system (malfunction 39).

END OF TESTING!

**48. VEHICLE SAGS**

- Step 1. Inspect leaf springs for breaks or damage.  
Replace any leaf springs that may cause the vehicle to sag (para. 7-12 or 7-16).
- Step 2. Inspect front leaf spring shackles for breaks or worn bushings.  
Replace any broken or worn shackles (para. 7-13).

END OF TESTING!

**WINCH**

**49. WINCH INOPERATIVE**

- Step 1. Check transmission power takeoff linkage when front winch is inoperative and/or power divider linkage when rear winch (M764) is inoperative for bends, breaks, or improper adjustment.
  - a. If PTO linkage is bent, broken, or out of adjustment, replace or adjust (para. 13-20).
  - b. If power divider linkage is bent, broken, or out of adjustment, replace or adjust (para. 13-23).
- Step 2. Check front winch driveshaft for broken or missing shearpin. If shearpin is broken or missing, refer to TM 9-2320-361-10.
- Step 3. Check front winch propeller shaft for breaks.  
If propeller shaft is broken, replace (para. 13-6).
- Step 4. Check front winch cable for bends and kinks.  
If winch cable is broken or kinked, replace (para. 13-3).

END OF TESTING!

Table 2-2. Mechanical Troubleshooting (Contd).

MALFUNCTION	TEST OR INSPECTION	CORRECTIVE ACTION
<b>50. WINCH OPERATES IN ONE DIRECTION ONLY</b>		
	Step 1. Check winch control linkage for bends or kinks.	If winch control linkage is bent or kinked, replace (para. 13-8).
	Step 2. Check transmission PTO linkage for bends or improper adjustment.	If PTO linkage is bent or out of adjustment, replace or adjust (para. 13-20).
		END OF TESTING!
<b>51. OPERATES AT ONE SPEED ONLY</b>		
	Check throttle control linkage for damage.	If throttle control linkage is damaged, replace (para. 3-35).
		END OF TESTING!
<b>52. DRAG BRAKE DOES NOT OPERATE</b>		
	Check drag brake adjustment.	a. Adjust drag brake as necessary (para. 13-2).
		b. If adjustment will not correct drag brake operation, replace winch (para. 13-5 or 13-18).
		END OF TESTING!
<b>53. WINCH DOES NOT HOLD LOAD WHEN POWER RELEASED</b>		
	Check automatic brake adjustment.	Adjust automatic brake as necessary (para. 13-4).
		END OF TESTING!
<b>54. AUTOMATIC BRAKE OVERHEATS</b>		
	Step 1. Check weight limits of winch and adjust size of load or use snatch block.	
	Step 2. Check automatic brake adjustment.	Adjust if necessary (para. 13-4).
		END OF TESTING!
<b>55. VEHICLE ROLLS WHILE OPERATING REAR WINCH</b>		
	Check parking brake for proper adjustment.	Adjust parking brake (para. 8-3).
		END OF TESTING!
<b>POWER TAKEOFF</b>		
<b>56. POWER TAKEOFF NOISY</b>		
	Step 1. Inspect PTO propeller shaft for proper lubrication.	Lubricate propeller shaft if required (LO 9-2320-209-12-1).
	Step 2. Inspect PTO propeller shaft for bends. If propeller shaft is bent, replace (para. 13-21).	
		END OF TESTING!



Table 2-2. Mechanical Troubleshooting (Contd).

MALFUNCTION	TEST OR INSPECTION	CORRECTIVE ACTION
-------------	--------------------	-------------------

**57. POWER TAKEOFF DIFFICULT TO SHIFT**

- Step 1. Inspect PTO shift linkage for improper lubrication.  
Lubricate PTO shift linkage if necessary (LO 9-2320-209-12-1).
- Step 2. Inspect PTO shift linkage for bends and cracks.  
If PTO shift linkage is bent or cracked, replace (para. 13-20).

END OF TESTING!

**58. (TRANSMISSION-DRIVEN) POWER TAKEOFF INOPERATIVE**

- Check power takeoff. Engage power takeoff and visually confirm output propeller shaft rotation.
  - a. If propeller shaft is noisy, inspect propeller shaft and universal joints. If propeller shaft is bent or universal joints have play, repair or replace (para. 13-6).
  - b. If propeller shaft is not rotating, inspect control linkage.  
Adjust control linkage and replace defective parts (para. 13-20).
  - c. If internal problem exists, notify your supervisor.

END OF TESTING!

**59. (TRANSFER-DRIVEN) POWER TAKEOFF INOPERATIVE**

- Check power takeoff. Engage and visually confirm output propeller shaft rotation.
  - a. If propeller shaft is noisy, inspect propeller shaft and universal joints.  
If propeller shaft is bent or universal joints have play, repair or replace (para. 7-2).
  - b. If propeller shaft is not rotating, inspect control linkage.  
Adjust control linkage and replace defective parts (para. 6-2 or 6-3).
  - c. If internal problem exists, notify your supervisor.

END OF TESTING!

**NONELECTRICAL GAGES**

**60. SPEEDOMETER OR TACHOMETER BOUNCES, NOISY, OR INOPERATIVE**

- Step 1. Inspect speedometer or tachometer drive shaft for binding and kinks.  
If drive shaft is bent or kinked, replace (para. 4-14, 4-15, or 4-16).
- Step 2. Remove speedometer or tachometer (para. 4-13) and check speedometer or tachometer cable operation.  
If cable is operating properly, replace speedometer or tachometer (para. 4-13).

END OF TESTING!

**61. AIR PRESSURE GAGE INOPERATIVE**

- Check operation of air pressure gage with known good air pressure gage.  
If test gage works properly, replace air pressure gage (para. 4-11).

END OF TESTING!

Table 2-2. Mechanical Troubleshooting (Contd).

MALFUNCTION	TEST OR INSPECTION	CORRECTIVE ACTION
-------------	--------------------	-------------------

**FIFTH WHEEL****62. TRAILER WILL NOT HITCH TO FIFTH WHEEL**

Inspect coupling jaws for bends and breaks.

If coupling jaws are broken or bent, replace fifth wheel (para. 12-113).

END OF TESTING!

**DUMP BODY (M342A2)****WARNING**

All personnel must stand clear during lifting operations. A snapped chain, swinging or shifting load result in cause injury or death to personnel.

**63. DUMP BODY WILL NOT RAISE**

Step 1. Check transmission PTO linkage for bends, breaks, or improper adjustment.

If transmission PTO linkage is bent, broken, or out of adjustment, replace or adjust (para. 13-20).

Step 2. Check all hydraulic lines for leaks, cracks, and breaks.

a. Tighten any loose fittings or loose hose connections.

b. If hoses are cracked or leaking, notify your supervisor.

Step 3. Visually check control valve for leaks and damage.

If leaking or damaged, notify your supervisor.

Step 4. Inspect pump housing for leaks and overheating with PTO engaged.

If pump is defective, notify your supervisor.

Step 5. Check control box, linkage, and lock operation. Move main control levers in cab and observe control box levers movement.

If control box lever, tailgate linkage, and lock will not operate, repair or replace (para. 12-11 or 12-12).

Step 6. Check hydraulic system for leaks.

If hydraulic hose fittings are leaking, notify your supervisor.

END OF TESTING!

**64. DUMP BODY DOES NOT LOWER**

Step 1. Check to ensure braces are not in raised position under dump body.

Lower and stow braces (TM 9-2320-361-10).

Step 2. Check control valve movement in and out.

If shaft will not move, notify your supervisor.

END OF TESTING!

**65. DUMP BODY DOES NOT HOLD IN RAISED POSITION**

Step 1. Check all hydraulic lines for leaks and cracks.

Tighten any loose connections.

If hoses are damaged, notify your supervisor.

Step 2. Check control valve for leaks.

If leaking, notify your supervisor.

Table 2-2. Mechanical Troubleshooting (Contd).

MALFUNCTION	TEST OR INSPECTION	CORRECTIVE ACTION
-------------	--------------------	-------------------

Step 3. Check hoist cylinder hoses for restrictions. If hydraulic hoses are restricted, notify your supervisor.

Step 4. Check control valve lever travel and adjustment.

a. If control valve lever travel and adjustment is incorrect, notify your supervisor.

b. If control valve shaft will not operate when control box is operated, notify your supervisor.

END OF TESTING!

**66. HYDRAULIC PUMP NOISY**

Check oil level in reservoir (LO 9-2320-209-12-1).

a. If fluid level is low, fill to proper level (LO 9-2320-209-12-1).

b. If hydraulic pump is still noisy, notify your supervisor.

END OF TESTING!

**67. TAILGATE DOES NOT OPEN**

Check for bent or broken linkage.

If linkage is bent or broken, notify your supervisor.

END OF TESTING!

**EARTH BORING AND POLESETTING (M764)**

**68. EARTH BORING MACHINE WILL NOT OPERATE**

Step 1. Check power divider control linkage for bends, breaks, or improper adjustment.

If power divider controls are bent, broken, or out of adjustment, refer to para. 13-23.

Step 2. Check power divider and earth boring propeller shafts and universal joints for breaks. If propeller shafts or universal joints are broken, refer to para. 13-21.

END OF TESTING!

**69. EARTH BORING MACHINE CANNOT BE MOVED VERTICALLY**

Check vertical drivechains for breaks or improper adjustment.

a. If vertical drivechains are broken, refer to para. 12-84.

b. If vertical drivechains are out of adjustment, notify your supervisor.

END OF TESTING!

**70. EARTH BORING MACHINE CANNOT BE MOVED HORIZONTALLY**

Check horizontal drivechains for breaks or improper adjustment.

a. If horizontal drivechains are broken, refer to para. 12-83.

b. If horizontal drivechains are out of adjustment, notify your supervisor.

END OF TESTING!

Table 2-2. Mechanical Troubleshooting (Contd).

MALFUNCTION	TEST OR INSPECTION	CORRECTIVE ACTION
-------------	--------------------	-------------------

**OUTRIGGERS (M764)****71. OUTRIGGERS INOPERATIVE**

Step 1. Check hydraulic lines, valve, and pump for leaks.

- a. Tighten loose connections.
- b. If hoses, valve, or pump are damaged, notify your supervisor.

Step 2. Check outrigger pump propeller shaft for breaks.

If broken, replace propeller shaft (para. 12-87).

END OF TESTING!

**72. OUTRIGGERS OPERATE SLOWLY**

Check for cracked, broken, or loose hydraulic hoses.

- a. Tighten loose connections.
- b. If hoses are cracked or broken, notify your supervisor.

END OF TESTING!

**FUEL TANK (M49A2C)****WARNING**

Diesel fuel is flammable. Do not perform fuel system procedures near open flame. Injury or death to personnel may result.

**73. FUEL DOES NOT PUMP FROM COMPARTMENTS, OR PUMPS SLOWLY**

Step 1. Inspect transfer PTO for proper operation.

If transfer PTO is inoperative, check PTO linkage for proper adjustment (para. 6-2).

Step 2. Check fusible link to make sure it is mounted to pin, and check fusible link for breaks.

If fusible link is broken or not mounted properly, replace or reinstall (para. 12-21).

Step 3. Check delivery pump propeller shaft for breaks and damaged universal joints.

If propeller shaft is broken or universal joints need replacement, replace (paras. 12-49 through 12-52).

Step 4. Perform fuel filter separator check (TM 9-2320-361-10).

If fuel filter separator is restricted, replace filter (para. 12-39).

Step 5. Check delivery pump strainer for restrictions.

- a. If restricted, clean or replace delivery strainer (para. 12-40).
- b. If fuel filter separator is not restricted and fuel pressure is low, replace delivery pump (para. 12-33).

END OF TESTING!

**74. DELIVERY PUMP DISPENSES FUEL SLOWLY FROM BOTH TANKS**

Step 1. Perform fuel filter separator check (TM 9-2320-361-10).

If fuel filter separator is restricted, replace filter (para. 12-39).

Table 2-2. Mechanical Troubleshooting (Contd).

MALFUNCTION	TEST OR INSPECTION	CORRECTIVE ACTION
-------------	--------------------	-------------------

- Step 2. Check delivery pump strainer for restrictions.
  - a. If restricted, clean or replace delivery pump strainer (para. 12-40).

**NOTE**

If no. 2 diesel fuel is being used and ambient air temperature is 32°F (0°C), the outlet pressure could be as low as 5 psi (34.5 kPa) (TM 9-2320-361-10 for fuel filter separator inlet and outlet pressure differences).

- b. If fuel system is clean and pressure is low, replace delivery pump (para. 12-33).
- Step 3. Check PTO speed control linkage for proper operation and adjustment (para. 13-20).
- Step 4. Check discharge valve control levers operation.
  - a. If control levers operation is defective, remove and inspect (para. 12-20).
  - b. If control lever assembly components are defective, replace (para. 12-20).
- Step 5. Check transfer case power takeoff operation,
  - If transfer case power takeoff is not operating, perform malfunction 59.

END OF TESTING!

**75. FUEL DOES NOT PUMP OR PUMPS FUEL SLOWLY FROM SELECTED TANK, AND FUEL DRAINS SLOWLY FROM SELECTED TANK USING GRAVITY PROCEDURES**

- Step 1. Check discharge control cables for proper lubrication (LO 9-2320-209-12-1).
- Step 2. Check discharge control cable for breaks or kinks.
  - If discharge control cable is broken or kinked, replace (para. 12-20).
- Step 3. Check discharge control cable for proper adjustment.
  - If control cable needs adjustment, remove slack in cable (para. 12-20).
- Step 4. Inspect discharge valve tubes for bent, crushed, broken, or leaking tubes.
  - Replace discharge valve tubes if bent, crushed, broken, or leaking (para. 12-21).
- Step 5. Inspect discharge valves for proper operation.
  - If discharge valves are broken or inoperative, replace (para. 12-18 or 12-19).

END OF TESTING!

**76. FUEL TANK COMPARTMENTS CANNOT BE SUCTION FILLED**

- Step 1. Check delivery pump propeller shaft for broken universal joints or broken shaft.
  - a. If shaft is broken, replace (para. 12-49 or 12-51).
  - b. If universal joints are broken, replace (para. 7-4).
- Step 2. Perform fuel filter separator check (TM 9-2320-361-10).
  - If fuel filter separator is restricted, replace (para. 12-39).
- Step 3. Check delivery pump strainer for restrictions.
  - a. If strainer is restricted, clean or replace (para. 12-40).

**NOTE**

If no. 2 diesel fuel is being used and ambient air temperature is 32°F (0°C), the outlet pressure could be as low as 5 psi (34.5 kPa) (TM 9-2320-361-10 for fuel filter separator inlet and outlet pressure differences).

- b. If fuel system is clean and pressure is low, replace delivery pump (para. 12-33).

Table 2-2. Mechanical Troubleshooting (Contd).

MALFUNCTION	TEST OR INSPECTION	CORRECTIVE ACTION
-------------	--------------------	-------------------

**WATER TANK (M50A2 AND M50A3)**

**77. WATER CANNOT BE PUMPED FROM BOTH TANKS**

- Step 1. Check delivery pump driveshaft and universal joints for breaks.
  - a. If driveshaft is broken, replace (para. 12-49, 12-50, 12-51, or 12-52).
  - b. If universal joints are broken, replace (para. 7-4).
- Step 2. Check delivery pump drivechain and sprocket for breaks.
  - If delivery pump drivechain or sprocket is broken, replace (para. 12-33).
- Step 3. Check transfer PTO for proper operation.
  - a. If transfer PTO is inoperative, check PTO linkage for proper operation and adjustment (paras. 6-2 and 6-3).
  - b. If transfer PTO linkage is operating properly and transfer PTO is defective, notify your supervisor.
- Step 4. Check delivery pump strainer for contamination or restrictions.
  - a. If delivery pump strainer is restricted, clean or replace strainer (para. 12-40).
  - b. If water system is clean and delivery pump propeller is operating at correct speed, replace delivery pump (para. 12-33).

END OF TESTING!

**78. WATER CANNOT BE PUMPED OR PUMPS SLOWLY FROM SELECTED TANK, AND WATER DRAINS SLOWLY FROM SELECTED TANK USING GRAVITY PROCEDURES**

- Step 1. Check discharge control cables for proper lubrication (LO 9-2320-209-12-1).
- Step 2. Check discharge control cables for breaks, bends, or kinks.
  - If discharge control cable is broken, bent, or kinked, replace (paras. 12-44 through 12-46).
- Step 3. Check discharge control cable for improper adjustment.
  - If cable requires adjustment, remove slack in cable (para. 12-47).
- Step 4. Inspect discharge valve tubes for bent, crushed, broken, or leaking tube.
  - If discharge valve tubes are bent, crushed, broken, or leaking, replace (para. 12-44 or 12-45).
- Step 5. Inspect discharge valves for proper operation.
  - If discharge valves are broken or inoperative, replace (paras. 12-46).

END OF TESTING!

**79. WATER PUMPS OUT OF BOTH TANKS SLOWER THAN NORMAL**

- Step 1. Check transfer PTO speed control linkage for proper operation and adjustment (para. 12-53).
- Step 2. Remove suction strainer from suction hose and check for restrictions (para. 12-40).
  - If suction strainer is restricted, clean or replace (para. 12-40).
- Step 3. Check delivery pump strainer for restrictions.
  - a. If delivery pump strainer is restricted, clean or replace (para. 12-40).
  - b. If water system is clean and water still pumps slowly, replace delivery pump (para. 12-33).

END OF TESTING!

Table 2-2. Mechanical Troubleshooting (Contd).

MALFUNCTION	TEST OR INSPECTION	CORRECTIVE ACTION
-------------	--------------------	-------------------

**80. WATER TANK COMPARTMENTS CANNOT BE SUCTION FILLED**

- Step 1. Check delivery pump propeller shafts for broken universal joints or broken shaft.
  - a. If shaft is broken, replace (para. 12-49, 12-50, 12-51, or 12-52).
  - b. If universal joints are broken, replace (para. 7-4).
- Step 2. Remove suction strainer from suction hose and check for restrictions (para. 12-40).  
If suction strainer is restricted, clean or replace (para. 12-40).
- Step 3. Check transfer PTO for proper operation.
  - a. If transfer PTO is inoperative, check transfer PTO linkage for proper operation and adjustment (para. 6-2 and 6-3).
  - b. If transfer PTO linkage is operating properly and transfer PTO is inoperative, notify your supervisor.
- Step 4. Check delivery pump strainer for restrictions.
  - a. If delivery pump strainer is restricted, clean or replace (para. 12-40).
  - b. If water system is clean and delivery pump driveshaft is operating at correct speed, replace delivery pump (para. 12-33).

END OF TESTING!

**PERSONNEL FUEL BURNING HEATER/POWER PLANT HEATER KIT**

**81. HEATER WILL NOT OPERATE IN HIGH OR LOW POSITION**

Refer to electrical troubleshooting table 2-4, malfunction 41.

**82. HEATER WILL NOT OPERATE**

**WARNING**

- Diesel fuel is flammable. Do not perform fuel system procedures near open flame. Injury or death to personnel may result.
- Compressed air source will not exceed 30 psi (207 kPa). When cleaning with compressed air, eyeshields must be worn. Failure to wear eyeshields may result in injury to personnel.

- Step 1. Refer to electrical troubleshooting table 2-4, malfunction 41.  
Perform electrical wire continuity tests. If defective, repair wires and connectors (table 2-4, malfunction 41).
- Step 2. Check fuel shutoff valve and make sure it is in full ON position.  
If fuel shutoff valve is damaged (or stuck in OFF or partial ON position), notify your supervisor.
- Step 3. Check heater fuel filter for contamination (para. 14-5).  
If water or contamination is present, clean and flush entire fuel system. Dry with compressed air.
- Step 4. Check fuel lines for breaks, bends, kinks, or leaking joints.  
If broken, kinked, or leaky joints are found, notify your supervisor.

Table 2-2. Mechanical Troubleshooting (Contd).

MALFUNCTION	TEST OR INSPECTION	CORRECTIVE ACTION
-------------	--------------------	-------------------

Step 5. Check fuel pump discharge.

- a. Remove fuel line from fuel pump output (para. 14-4).
- b. Use clean container for fuel discharge recovery.
- c. Position heater control box to RUN position.
- d. If fuel pump fails to pump adequate amount of fuel, 1/2-pint (0.24 liter) in 30 seconds, replace (para. 14-4).

Step 6. Inspect exhaust system for restrictions.

If exhaust pipe is restricted or damaged, repair or replace (para. 14-6).

Step 7. If fuel burning heater still fails to operate, replace fuel burning heater (para. 14-2).

Step 8. Check for proper operation of defroster and heat diverter control cables (TM 9-2320-361-10).

If control cables or vent are broken, replace (paras. 11-40 and 11-41).

END OF TESTING!



## Section V. COMPRESSED AIR AND BRAKE SYSTEM TROUBLESHOOTING

### 2-13. GENERAL

a This section provides information to diagnose and correct malfunctions of the compressed air and brake system. Because of its complexity, the compressed air and brake system is divided into the following functional components:

- Parking Brake (page 2-54)
- Service Brakes (page 2-56)
- Compressed Air (page 2-62)
- Air-Operated Accessories (page 2-71)

b. The air and brake system schematic (Appendix E) shows interrelationship of these systems, and should be used as a reference when performing compressed air and brake system troubleshooting.

c. Each malfunction symptom given for an individual component or system is followed by step(s) you should take to determine the cause and corrective action you must take to remedy the problem.

d. Before taking any action to correct a possible malfunction, the following rules should be followed:

- (1) Question operator to obtain any information that might help you to determine the cause of the problem.
- (2) Never overlook the chance that the problem could be of simple origin. The problem could be corrected with minor adjustment.
- (3) Use all senses to observe and locate troubles.
- (4) Use test instruments or gages to help you to determine and isolate problems.
- (5) Always isolate the system where the malfunction occurs and then locate the defective component.
- (6) Use standard automotive theories and principles when troubleshooting the vehicles covered in this manual.

#### **WARNING**

Do not disconnect air lines before draining air reservoirs. Small parts under pressure may shoot out with high velocity, causing injury to personnel.

**TROUBLESHOOTING SYMPTOM INDEX**

MALFUNCTION NO.	MALFUNCTION	TROUBLESHOOTING PROCEDURE PAGE
<b>PARKING BRAKE</b>		
1.	Parking brake will not hold vehicle . . . . .	2-54
2.	Parking brake drags . . . . .	2-54
<b>SERVICE BRAKES</b>		
3.	Brake pedal low, soft, or goes to floorboard (weak or no braking) . . . . .	2-56
4.	Excessive pedal pressure required to stop vehicle (brake pedal stops two inches or more above floorboard); no apparent air system failure . . . . .	2-58
5.	Vehicle pulls to right or left when applying brakes . . . . .	2-60
6.	Brakes drag . . . . .	2-61
7.	Brakes squeal . . . . .	2-62
<b>COMPRESSED AIR</b>		
8.	Excessive pedal pressure required to stop vehicle when towing a trailer M275A2) . . . . .	2-62
9.	No air pressure or compressed air reads below 60 psi (low air pressure warning buzzer sounding indicating air pressure not building up to normal operating range as indicated by gage) . . . . .	2-66
10.	Air pressure does not build up to normal operating pressure (above 85 psi) according to gage . . . . .	2-68
11.	Air pressure exceeds maximum (gage reads over 120 psi) and safety valve opens to release pressure . . . . .	2-68
12.	Low, or no reading on air pressure gage and warning buzzer shuts off . . . . .	2-70
13.	Warning buzzer fails to sound on low pressure (below 60 psi). . . . .	2-70
<b>AIR-OPERATED ACCESSORIES</b>		
14.	Windshield wipers inoperative or operate slowly (gage at normal operating pressure) . . . . .	2-71
15.	Front wheel drive does not engage (front wheel drive lock-in switch engaged) . . . . .	2-72
16.	Air horn does not work . . . . .	2-73

Table 2-3. Compressed Air and Brake System Troubleshooting.

MALFUNCTION	TEST OR INSPECTION	CORRECTIVE ACTION
-------------	--------------------	-------------------

**WARNING**

**ASBESTOS DUST**

Do not use a dry brush or compressed air to clean brakeshoes. There may be asbestos dust on brakeshoes which can be dangerous to your health if you breath it. (Brakeshoe must be wet, and a soft bristle brush must be used.)

**PARKING BRAKE**

**1. PARKING BRAKE WILL NOT HOLD VEHICLE**

- Step 1. Check parking brake cable (1) for breaks, bends, or improper adjustment.
  - a. Replace parking brake cable (1) if broken or bent (para. 8-4).
  - b. Adjust parking brake cable (1) if out of adjustment (TM 9-2320-361-10).
- Step 2. Inspect parking brakeshoes (5) for wear.
  - If parking brakeshoe (5) linings are worn more than 0.188 in. (4.78 mm), replace (para. 8-3).
- Step 3. If parking brakeshoe (5) linings and drum (4) are oily, replace parking brakeshoes (para. 8-3) and clean drum (4).
- Step 4. Check parking brakeshoe (5) clearance adjustment (para. 8-3).
  - If parking brakeshoe (5) clearance is out of adjustment, adjust (para. 8-3).

END OF TESTING!

**2. PARKING BRAKE DRAGS**

- Step 1. Check brakeshoe retracting spring (2) and lever retracting spring (3) for breaks, bends, missing, or disconnected conditions.
  - a. Reconnect brakeshoe retracting spring (2) or lever retracting spring (3) if disconnected.
  - b. If brakeshoe retracting spring (2) or lever retracting spring (3) is broken, bent, or missing, replace (para. 8-3).
- Step 2. Check parking brake cable (1) for binding or improper adjustment.
  - If parking brake cable (1) is binding or out of adjustment, replace (para. 8-4) or adjust (TM 9-2320-361-10).
- Step 3. Perform step 4 of malfunction 1.

Table 2-3. Compressed Air and Brake System Troubleshooting (Contd).

MALFUNCTION	TEST OR INSPECTION	CORRECTIVE ACTION
-------------	--------------------	-------------------

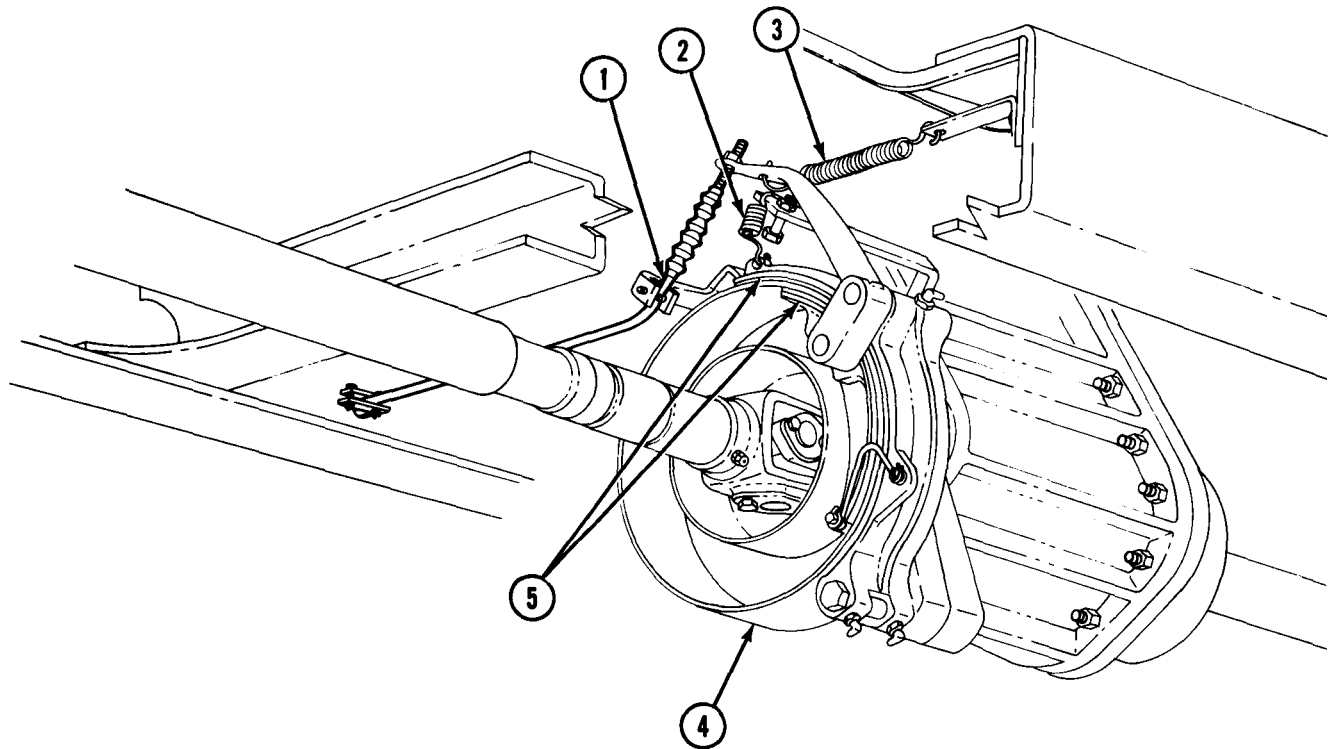

END OF TESTING!

Table 2-3. Compressed Air and Brake System Troubleshooting (Contd).

MALFUNCTION	TEST OR INSPECTION	CORRECTIVE ACTION
-------------	--------------------	-------------------

**SERVICE BRAKES**

**WARNING**

Ensure new longer front brake hoses, currently used on 5-ton trucks, are installed on all 2-1/2-ton trucks. Old shorter front brake hoses are subject to failure during full steering travel and must be replaced with new longer front brake hose. Failure to do this may result in injury or death to personnel.

**NOTE**

Old shorter front brake hoses should be replaced with new longer front brake hoses (para. 8-16).

**3. BRAKE PEDAL LOW, SOFT, OR GOES TO FLOORBOARD (WEAK OR NO BRAKING)**

Step 1. Check master cylinder fluid level.

If fluid level is low, fill to proper level (LO 9-2320-209-12-1).

Step 2. Check wheel cylinders (2), hydraulic brake lines (1), and hoses for leaks, cracks, breaks, or loose connections.

a. If hydraulic brake lines (1) or hoses are loose, tighten.

b. If hydraulic brake lines (1) or hoses are broken, cracked, or leaking, replace (para. 8-15, 8-16, or TM 9-243).

c. If wheel cylinders (2) are leaking, replace (para. 8-9).

Step 3. Check for air in service brake system.

Bleed service brake system (para. 8-12).

Step 4. Check service brake hydraulic fluid for contamination.

If fluid is contaminated, flush entire brake system (para. 8-12).

Step 5. Check service brakeshoes (3) for proper adjustment and check service brakeshoe (3) linings for wear.

a. Adjust service brakeshoes (3) if necessary (para. 8-8).

b. If service brakeshoe (3) linings are worn more than 0.328 in. (8.33 mm), replace (para. 8-7).

Step 6. Remove two screws (6) and shield (7) from air-hydraulic cylinder (4).

Step 7. Inspect master cylinder (5) for leaks.

If master cylinder (5) is leaking, replace (para. 8-10).

Step 8. Inspect air-hydraulic cylinder (4) for brake fluid leaks.

If air-hydraulic cylinder (4) is leaking brake fluid, replace (para. 8-11).

Step 9. Perform master cylinder (5) internal leakage test (para. 8-10).

a. If master cylinder (5) is leaking internally, replace (para. 8-10).

b. If master cylinder (5) is good, and malfunction still exists, replace air-hydraulic cylinder (4) (para. 8-11).

MALFUNCTION	TEST OR INSPECTION	CORRECTIVE ACTION
-------------	--------------------	-------------------

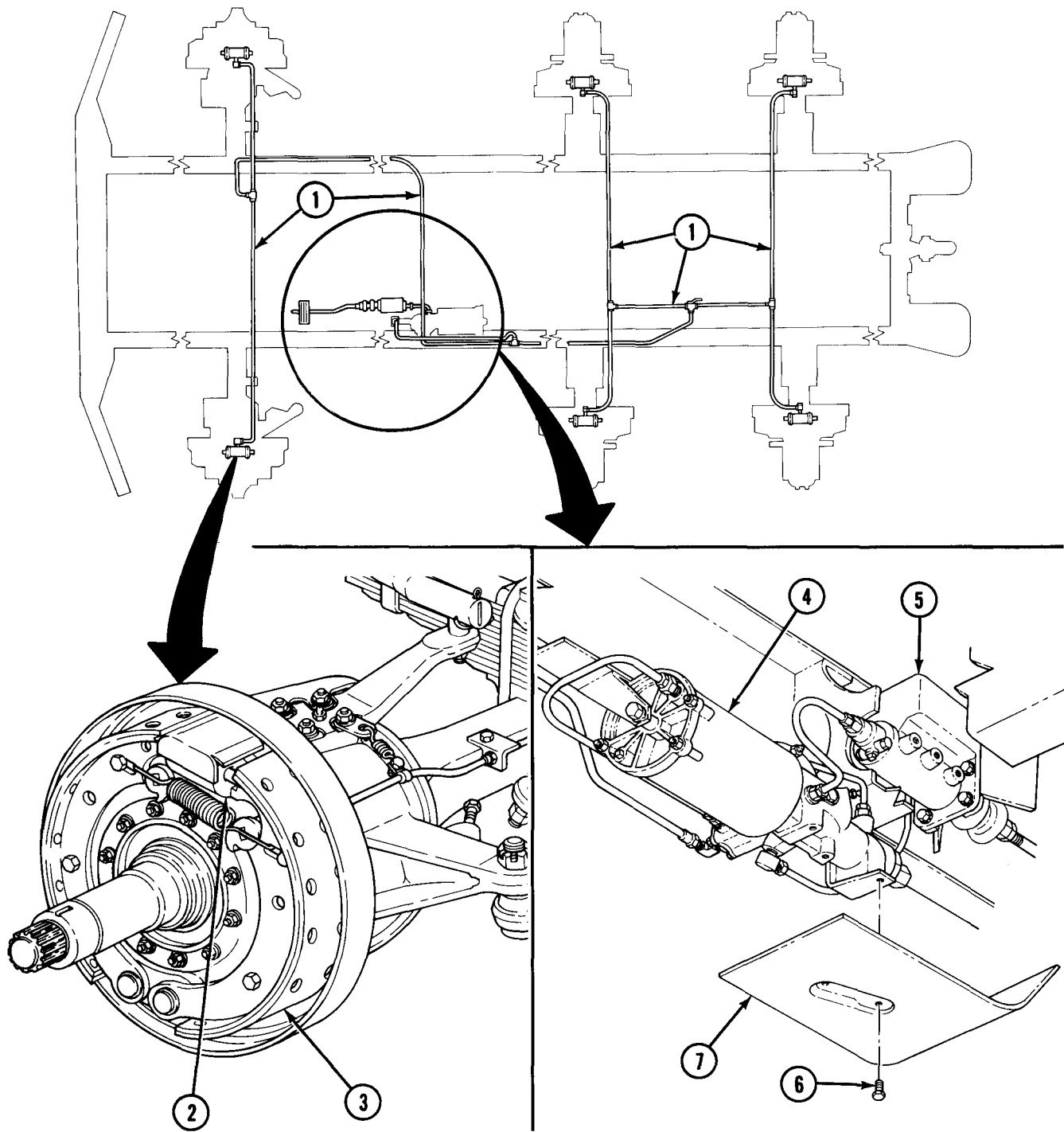

END OF TESTING!

Table 2-3. Compressed Air and Brake System Troubleshooting (Contd).

MALFUNCTION	TEST OR INSPECTION	CORRECTIVE ACTION
-------------	--------------------	-------------------

**4. EXCESSIVE PEDAL PRESSURE REQUIRED TO STOP VEHICLE (BRAKE PEDAL STOPS TWO INCHES OR MORE ABOVE FLOORBOARD); NO APPARENT AIR SYSTEM FAILURE**

Step 1. Check service brakeshoe (1) linings for oil or grease contamination.

If service brakeshoe (1) linings are saturated with oil or grease, repair oil or grease leak and replace brakeshoes (para. 8-7).

Step 2. Direct assistant to apply service brakes and listen for evidence of air escaping at air-hydraulic cylinder (2) and at vent (5).

a. If escaping air is present, replace air-hydraulic cylinder (para. 8-11).

b. If no air is escaping, proceed to test 1.

Test 1. Check air-hydraulic cylinder (2) for proper delivery line (7) supply pressure.

Step 1. Stop engine and open all draincocks (TM 9-2320-361-10) until brake system air pressure is vented.

Step 2. Remove two screws (3) and shield (4) from air-hydraulic cylinder (2).

Step 3. Disconnect delivery line (7) from elbow (6).

Step 4. Remove elbow (6) from air-hydraulic cylinder (2).

Step 5. Install tee (9) on air-hydraulic cylinder (2).

Step 6. Connect test gage (8) to tee (9) and connect delivery line (7) to tee (9).

Step 7. Direct assistant to start engine (TM 9-2320-361-10) and allow air pressure to build to normal operating pressure.

Step 8. Check test gage (8) reading and compare with reading on instrument panel air pressure gage.

**NOTE**

Air pressure gage in instrument panel has a maximum pressure scale of 120 psi. If old governor has been replaced with new governor, air pressure may exceed maximum pressure reading on instrument panel gage.

a. If reading on test gage (8) is same as instrument panel air pressure gage, replace air-hydraulic cylinder (2) (para. 8-11).

b. If reading on test gage (8) is less than instrument panel air pressure gage, check delivery line (7) for restrictions. If delivery line (7) is damaged or restricted, replace (para. 8-15).

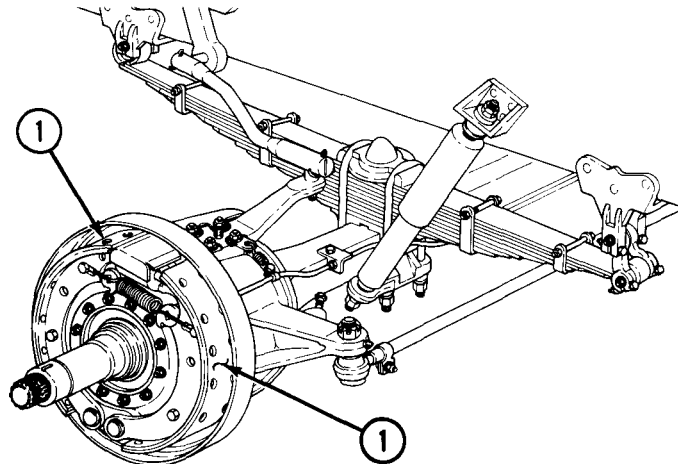
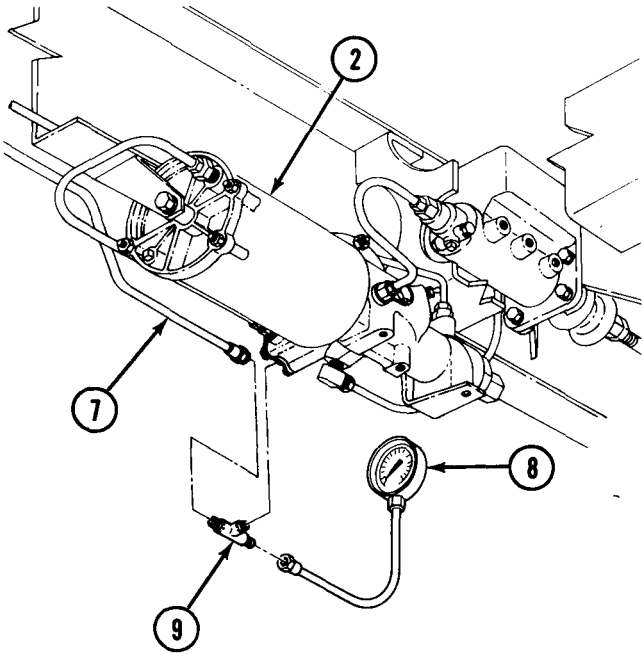
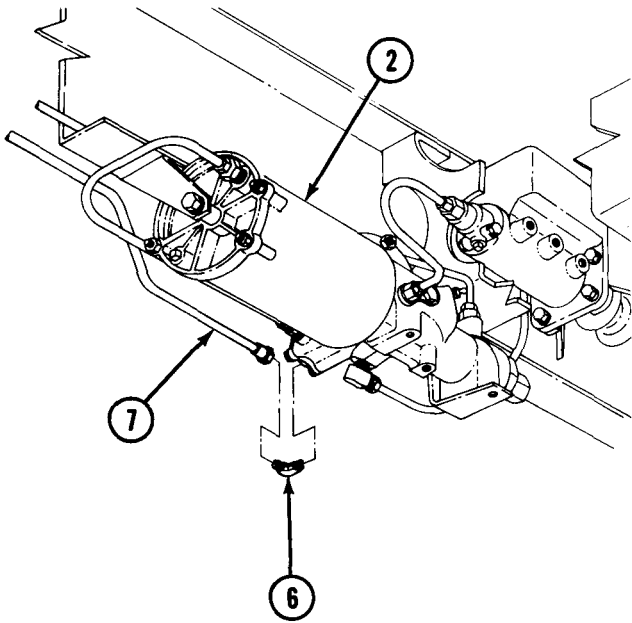
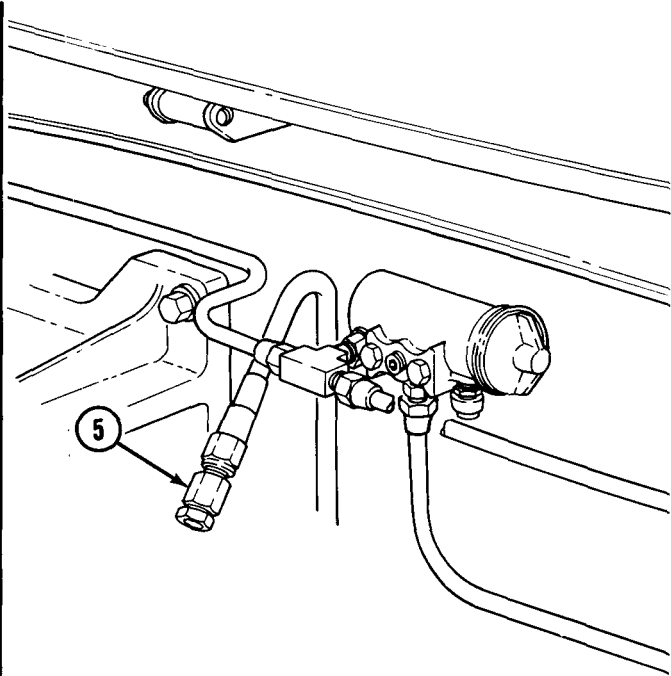
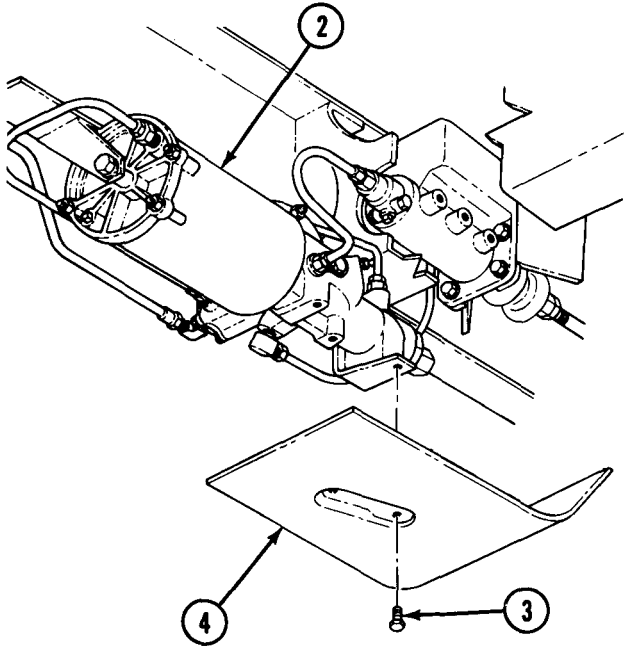

Table 2-3. Compressed Air and Brake System Troubleshooting (Contd).

MALFUNCTION	TEST OR INSPECTION	CORRECTIVE ACTION
-------------	--------------------	-------------------



END OF TESTING!

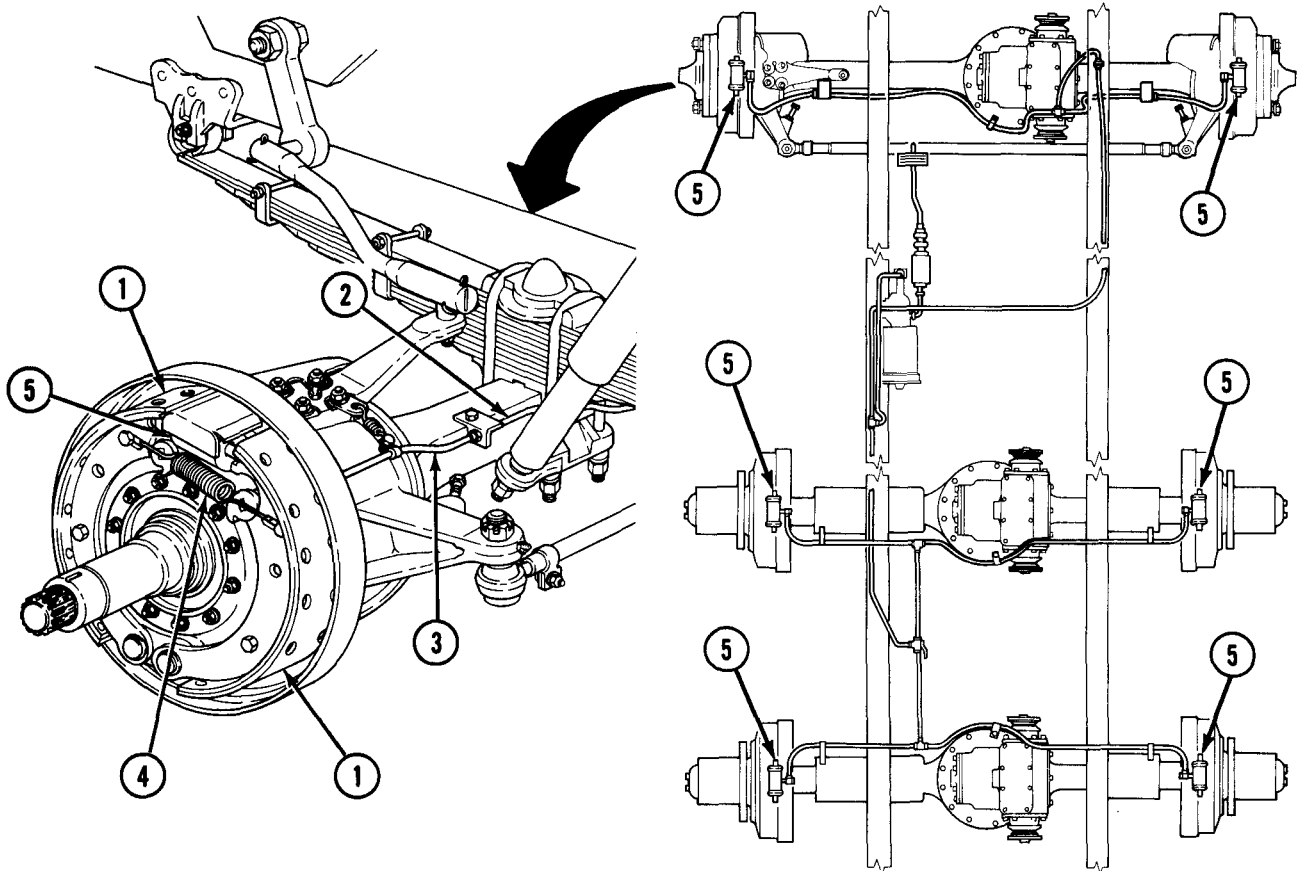

Table 2-3. Compressed Air and Brake System Troubleshooting (Contd).

MALFUNCTION	TEST OR INSPECTION	CORRECTIVE ACTION
-------------	--------------------	-------------------

**5. VEHICLE PULLS TO RIGHT OR LEFT WHEN APPLYING BRAKES**

- Step 1. Check clearances on each set of service brakeshoes (1). If service brakeshoes (1) are out of adjustment, adjust clearance (para. 8-8).
- Step 2. Check service brakeshoe (1) linings for wear.  
If service brakeshoe (1) linings are worn more than 0.328 in. (8.33 mm), replace service brakeshoes (1) (para. 8-7).
- Step 3. Check hydraulic brake lines (2) for bent or crushed conditions.  
Replace if hydraulic brake lines (2) are bent or crushed. Refer to TM 9-243 for instructions to double flare hydraulic brake lines (2).
- Step 4. Check hydraulic hoses (3) for pinches or cracks.  
If damaged, replace (para. 8-15).
- Step 5. Check brakeshoe return spring (4) for damage.  
If brakeshoe return spring (4) is broken or stretched, replace (para. 8-7).
- Step 6. Check wheel cylinders (5) to make sure wheel cylinder pistons move freely and are not frozen.  
If wheel cylinder pistons are frozen, replace wheel cylinders (5) (para. 8-9).



END OF TESTING!

Table 2-3. Compressed Air and Brake System Troubleshooting (Contd).

MALFUNCTION	TEST OR INSPECTION	CORRECTIVE ACTION
-------------	--------------------	-------------------

**6. BRAKES DRAG**

Step 1. Check brake pedal (6) free travel. Free travel should be 0.25-0.5 in. (6.35-12.7 mm).

Adjust brake pedal (6) free travel (para. 8-14).

Step 2. Check hydraulic brake lines (2) for bends, kinks, or restrictions.

Replace if hydraulic brake lines (2) are bent, kinked, or restricted. Refer to TM 9-243 for instructions to double flare hydraulic brake lines (2).

Step 3. Check service brakeshoes (1) adjustment (para. 8-8).

Step 4. Check service brake hydraulic fluid for contamination.

If fluid is contaminated, flush entire brake system (para. 8-12).

Step 5. Perform master cylinder (7) internal leakage test (para. 8-10).

a. If master cylinder (7) is leaking internally, replace (para. 8-10).

b. If master cylinder (7) is good, and malfunction still exists, replace air-hydraulic cylinder (8) (para. 8-11).

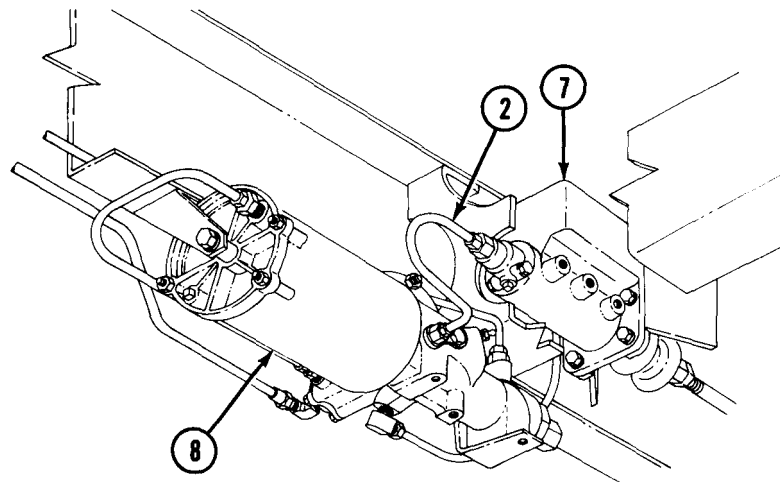
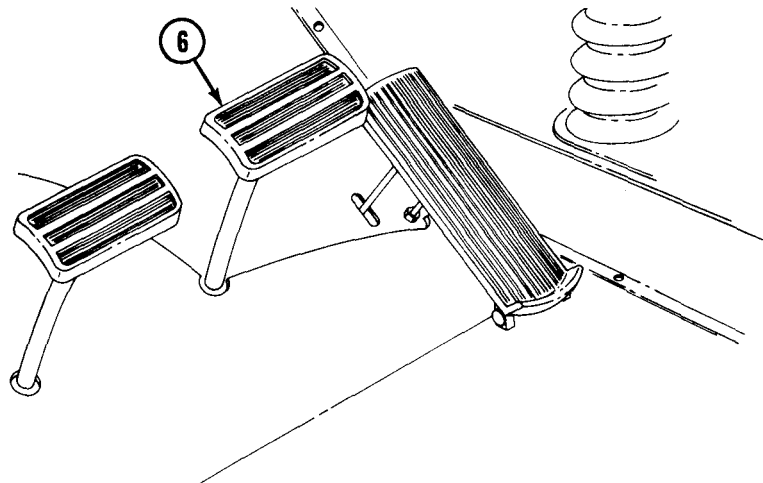

END OF TESTING!

Table 2-3. Compressed Air and Brake System Troubleshooting (Contd).

MALFUNCTION	TEST OR INSPECTION	CORRECTIVE ACTION
-------------	--------------------	-------------------

**7. BRAKES SQUEAL**

- Step 1. Check service brakeshoes (1) for proper installation, glazing, distortion, or excessive wear.
  - a. If service brakeshoes (1) are improperly installed, replace (para. 8-7).
  - b. If service brakeshoes (1) are glazed, distorted, or worn more than 0.328 in. (8.33 mm), replace (para. 8-7).
- Step 2. Check brakedrums (2) for heat spotting or heavy scoring.
  - If brakedrums (2) are heat-spotted or scored more than 0.03 in. (0.76 mm), replace (paras. 9-3 and 9-4).
- Step 3. Check brakedrum (2) and hub (4) for proper assembly.
  - If brakedrum (2) and hub (4) are not properly assembled, or if any screws (3) are missing, replace (para. 9-3 or 9-4).

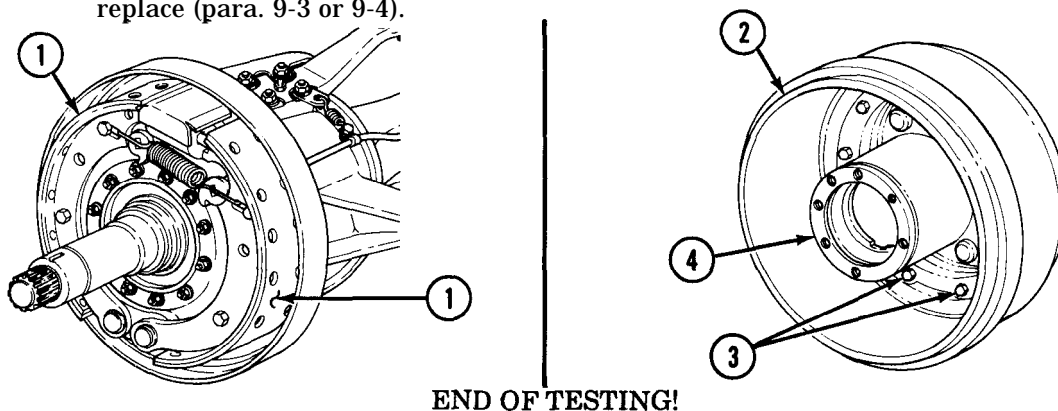

**COMPRESSED AIR**

**WARNING**

Do not disconnect air lines before draining air reservoirs. Small parts under pressure may shoot out with high velocity, causing injury to personnel.

**8. EXCESSIVE PEDAL PRESSURE REQUIRED TO STOP VEHICLE WHEN TOWING A TRAILER (M275A2)**

- Step 1. Start engine (TM 9-2320-361-10) and allow air pressure to build to normal operating pressure with trailer air lines disconnected from trailer and connected to dummy coupling and airbrake valves open.
- Step 2. Check lines, hoses, and rubber gaskets (10) for leaks.
- Step 3. Direct assistant to fully apply service brakes or pull down on trailer airbrake hand control.
  - a. If air leaks are found, repair as required.
  - b. If no air leaks are found, perform test 1.

**NOTE**

Perform test 1 on both trailer brake supply hoses.

Test 1. Check trailer brake supply hose (6) for proper pressure.

- Step 1. Stop engine and open all draincocks (TM 9-2320-361-10) until brake system air pressure is vented.
- Step 2. Remove quick-disconnect coupling (5) from trailer brake supply hose (6).

Table 2-3. Compressed Air and Brake System Troubleshooting (Contd).

MALFUNCTION	TEST OR INSPECTION	CORRECTIVE ACTION
-------------	--------------------	-------------------

Step 3. Install adapter (7) in trailer brake supply hose (6).

Step 4. Connect test gage (8) to adapter (7).

Step 5. Direct assistant to start engine (TM 9-2320-361-10) and allow air supply to build to normal operating pressure.

**NOTE**

- Service brake air pressure and airbrake hand control air pressure must not be checked at the same time.
- Air pressure must be held and maintained for pressure to equalize in air-hydraulic cylinder with air system pressure.

Step 6. Direct assistant to fully apply and hold service brakes or pull down on trailer airbrake hand control (TM 9-2320-361-10).

Step 7. Check test gage (8) reading and compare with reading on instrument panel gage.

**NOTE**

Air pressure gage on instrument panel has a maximum pressure scale of 120 psi. If old governor has been replaced with new governor, air pressure may exceed maximum pressure reading on instrument panel gage.

- a. If reading is lower than instrument panel gage reading, perform test 2.
- b. If reading compares with instrument panel gage, check trailer brake system for proper operation (TM 9-2320-213-14).

Step 8. Reinstall quick-disconnect coupling (5).

- a. Disconnect test gage (8) from adapter (7).
- b. Remove adapter (7) from trailer brake supply hose (6).
- c. Install quick-disconnect coupling (5) to trailer brake supply hose (6).
- d. Close all airbrake valves (TM 9-2320-361-10).
- e. Start engine (TM 9-2320-361-10) and ensure airbrake system pressurizes to normal operating pressure

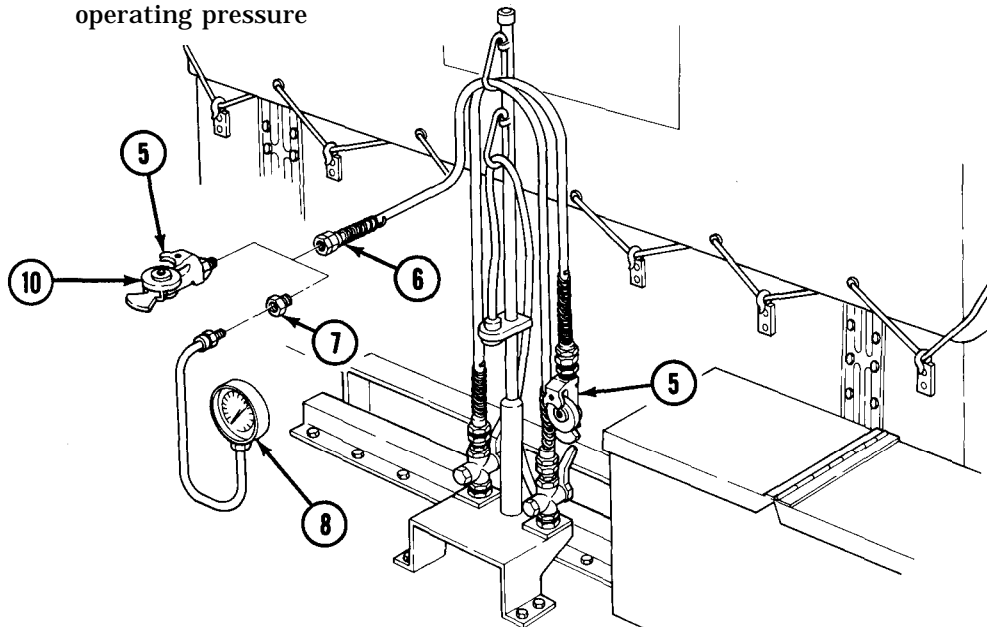

Table 2-3. Compressed Air and Brake System Troubleshooting (Contd).

MALFUNCTION	TEST OR INSPECTION	CORRECTIVE ACTION
-------------	--------------------	-------------------

Test 2. Check air pressure supply in protection valve (2).

Step 1. Stop engine and open all draincocks (TM 9-2320-361-10) until brake system air pressure is vented.

Step 2. Disconnect air brake supply hose (4) from safety protection valve elbow (3).

Step 3. Remove elbow (3) from safety protection valve (2).

Step 4. Install tee (6) in safety protection valve (2).

Step 5. Connect air brake supply hose (4) to tee (6) and connect test gage (5) to tee (6).

NOTE

- Service brake air pressure and airbrake hand control air pressure must not be checked at the same time.
- Air pressure must be held and maintained for pressure to equalize in air hydraulic cylinder with air system pressure.

Step 6. Direct assistant to fully apply and hold service brakes or pull down on airbrake hand control.

Step 7. Check test gage (5) reading.

- If readings are very low or build up very slowly, check all lines for bends, kinks, or restrictions. Repair or replace damaged lines (TM 9-243).
- If test gage (5) reads zero when service brakes are applied, replace air-hydraulic cylinder (1) (para. 8-11).
- If test gage (5) reads zero when airbrake hand control is applied, replace airbrake hand control (para. 8-21).

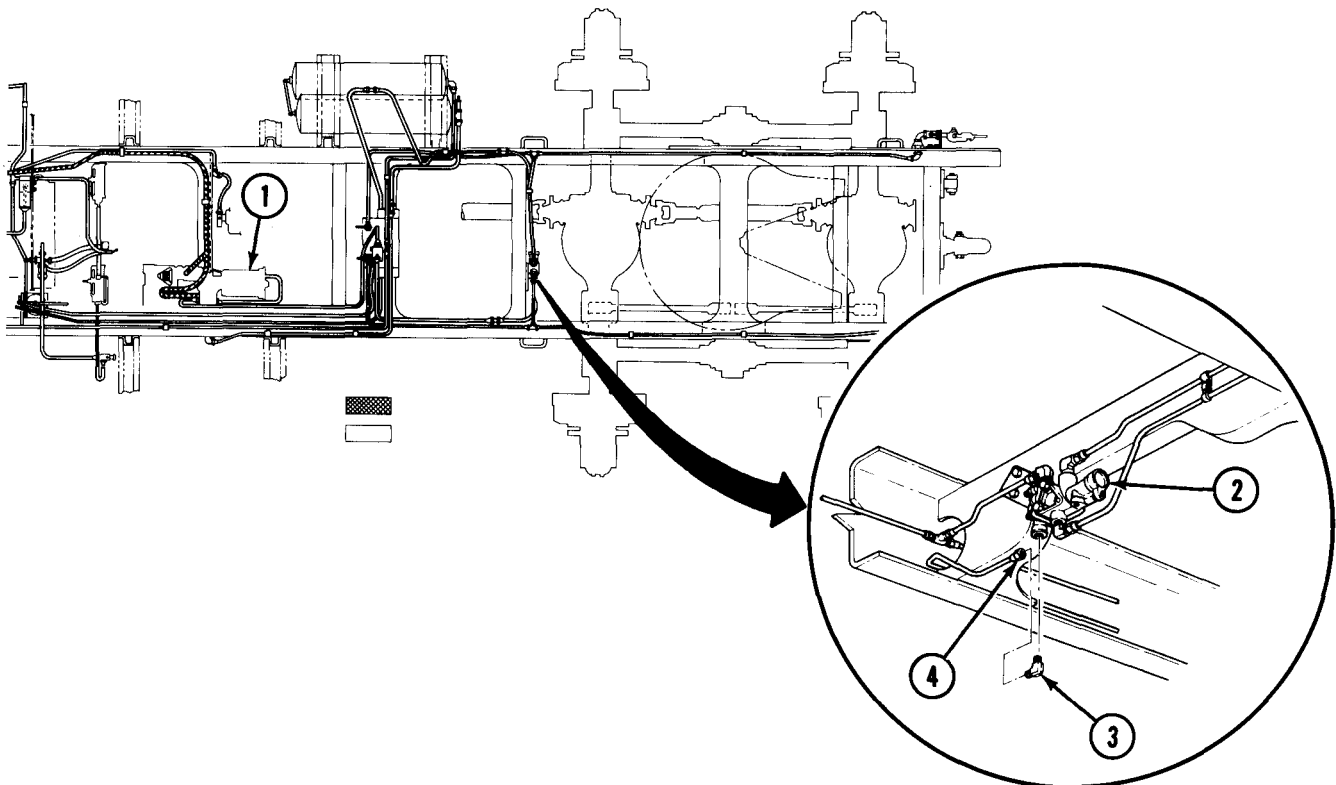

Table 2-3. Compressed Air and Brake System Troubleshooting (Contd).

MALFUNCTION	TEST OR INSPECTION	CORRECTIVE ACTION
-------------	--------------------	-------------------

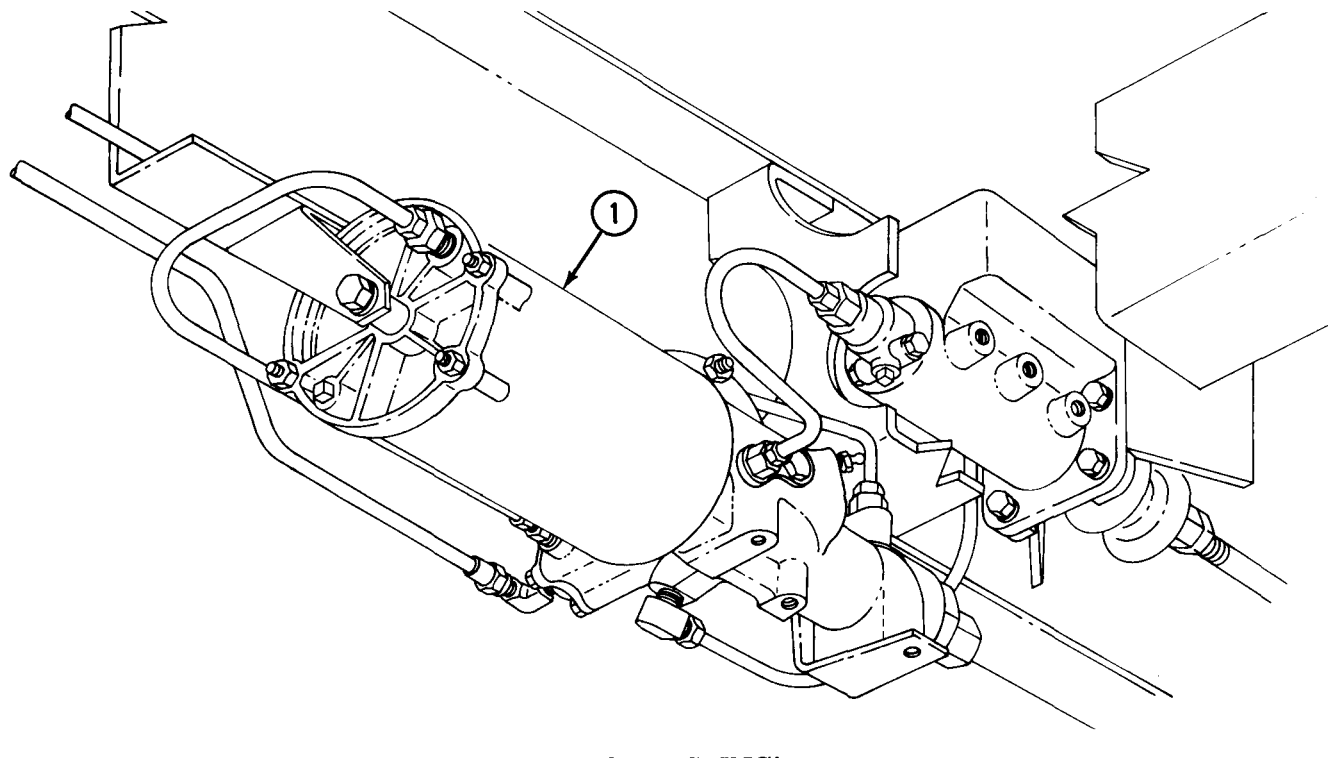
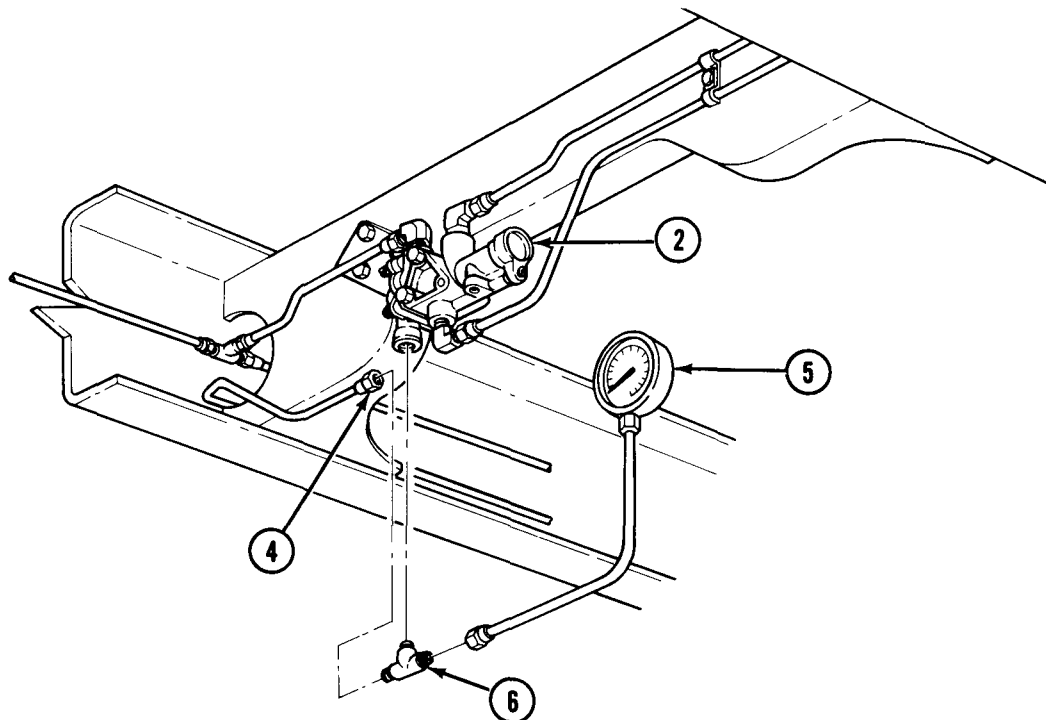

Table 2-3. Compressed Air and Brake System Troubleshooting (Contd).

MALFUNCTION	TEST OR INSPECTION	CORRECTIVE ACTION
-------------	--------------------	-------------------

**9. NO AIR PRESSURE OR COMPRESSED AIR READS BELOW 60 PSI (LOW AIR PRESSURE WARNING BUZZER SOUNDING, INDICATING AIR PRESSURE NOT BUILDING UP TO NORMAL OPERATING RANGE AS INDICATED BY GAGE)**

- Step 1. Check for missing or loose air compressor drivebelt (3).  
If air compressor drivebelt (3) is missing or loose, replace or adjust drivebelt (3) (para. 8-28).
- Step 2. Check for leaking compressed air lines and fittings.  
If leakage is found, repair or replace compressed air lines or fittings (TM 9-243).
- Step 3. Start engine (TM 9-2320-361-10) and feel compressor outlet line (5).
  - a. If compressor outlet line (5) is hot, proceed to test 1.
  - b. If compressor outlet line (5) is cool or warm, proceed to test 2.

Test 1. Check air reservoirs (1) for air pressure.

**WARNING**

Eyeshields must be worn when working with compressed air system.  
Failure to wear eyeshields may result in injury to personnel.

- Step 1. Start engine (TM 9-2320-361-10) and allow air pressure to build to normal operating pressure.
  - Step 2. Loosen air reservoir draincocks (2).
    - a. If a low volume of air pressure is released, perform step 3.
    - b. If a high volume of air pressure is released, proceed to test 2.
  - Step 3. Check compressor outlet line (5) for restrictions.
    - a. If compressor outlet line (5) is restricted, repair or replace (TM 9-243).
    - b. If compressor outlet line (5) is not restricted, proceed to test 2.
- Test 2. Check for air pressure at air horn supply line (7).
- Step 1. Stop engine and open all draincocks (2) (TM 9-2320-361-10) until brake system air pressure is vented.
  - Step 2. Disconnect air horn supply line (7) from air horn elbow (9).
  - Step 3. Connect air horn supply line (7) to test gage (8).
  - Step 4. Direct assistant to start engine (TM 9-2320-361-10) and allow sufficient time for pressure to build.
  - Step 5. Compare test gage (8) reading with gage reading on instrument panel.

**NOTE**

Air pressure gage on instrument panel has a maximum pressure scale of 120 psi. If old governor has been replaced with new governor, air pressure may exceed maximum pressure reading on instrument panel gage.

- a. If low or no air pressure is indicated on test gage (8), check air horn supply line (7) for restrictions or leaks. Repair or replace damaged compressed air lines (TM 9-243).
- b. If air compressor (4) is continuously unloading, not allowing air compressor to build air pressure, adjust air governor (6) (para. 8-29).
- c. If air governor (6) adjustment will not increase pressure and/or compressor outlet line (5) is warm or cool, replace air compressor (para. 8-26).

Table 2-3. Compressed Air and Brake System Troubleshooting (Contd).

MALFUNCTION	TEST OR INSPECTION	CORRECTIVE ACTION
-------------	--------------------	-------------------

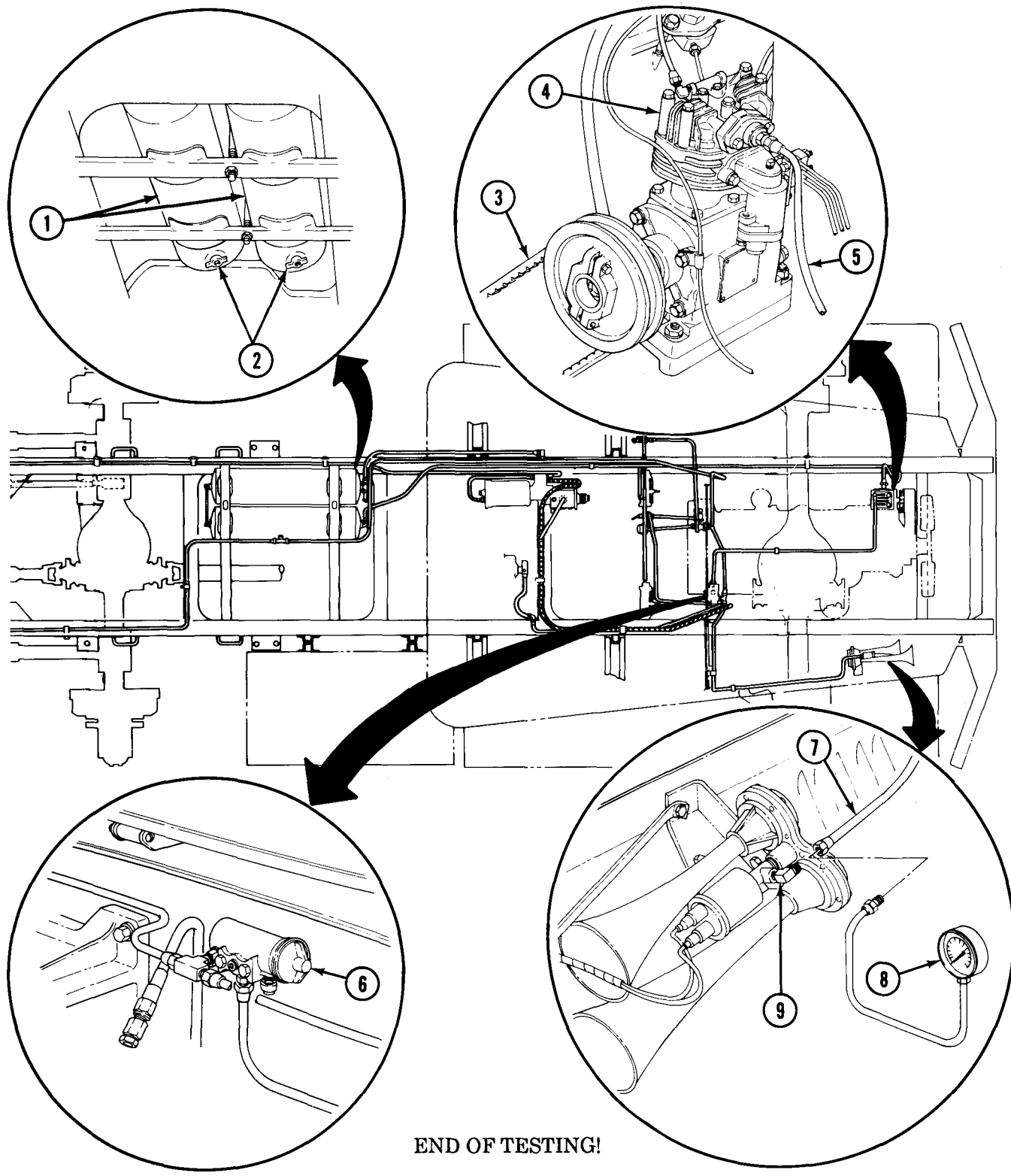

END OF TESTING!



Table 2-3. Compressed Air and Brake System Troubleshooting (Contd).

MALFUNCTION	TEST OR INSPECTION	CORRECTIVE ACTION
-------------	--------------------	-------------------

**10. AIR PRESSURE DOES NOT BUILD UP TO NORMAL OPERATING PRESSURE (ABOVE 85 PSI) ACCORDING TO GAGE**

Step 1. Check for compressed air leaks.

If leakage is found, repair or replace compressed air lines or fittings (TM 9-243).

Step 2. Adjust air governor (para. 8-29).

Step 3. Perform test 2 of malfunction 9.

END OF TESTING!

**NOTE**

Air pressure gage on instrument panel has a maximum pressure scale of 120 psi. If old governor has been replaced with new governor, air pressure may exceed maximum pressure reading on instrument panel gage.

**11. AIR PRESSURE EXCEEDS MAXIMUM (GAGE READS OVER 120 PSI) AND SAFETY VALVE OPENS TO RELEASE PRESSURE**

Step 1. Check for air loss through accessories (refer to malfunctions 14, 15, and 16).

**NOTE**

Step 2 applies to M275A2 only.

Step 2. Check for excessive air pressure as indicated by instrument panel gage.

If air pressure exceeds maximum and safety valve opens to release pressure, replace air governor (para. 8-29).

Step 3. Check governor signal line (4) for crimps, bends, or leaks.

a. If governor signal line (4) is crimped, bent, or leaking, repair or replace governor signal line (4) (para. 8-15).

b. If no restrictions are apparent, proceed to test 1.

Test 1. Check governor signal line (4) pressure.

Step 1. Stop engine and open all draincocks (TM 9-2320-361-10) until brake system air pressure is vented.

Step 2. Disconnect governor signal line (4) from adapter (3).

Step 3. Remove adapter (3) from air governor (2).

Step 4. Install tee (5) on air governor (2).

Step 5. Connect test gage (1) to tee (5) and governor signal line (4) to tee (5).

Step 6. Direct assistant to start engine (TM 9-2320-361-10) and allow air supply to built to normal operating pressure.

Table 2-3. Compressed Air and Brake System Troubleshooting (Contd).

MALFUNCTION	TEST OR INSPECTION	CORRECTIVE ACTION
-------------	--------------------	-------------------

Step 7. Compare air pressure reading indicated on test gage (1) to air pressure indicated on instrument panel gage.

**NOTE**

Step 7a applies to M275A2 only.

- If test gage (1) air pressure reading is the same as gage reading on instrument panel (exceeds maximum) and pressure protection valve continues to release pressure, replace air compressor (para. 8-26).
- If test gage (1) reading is below 85 psi (586 kPa), adjust governor (para. 8-29).
- If governor adjustment will not increase governor signal line (4) pressure above 85 psi (586 kPa) on test gage (1), replace air governor (para. 8-29).

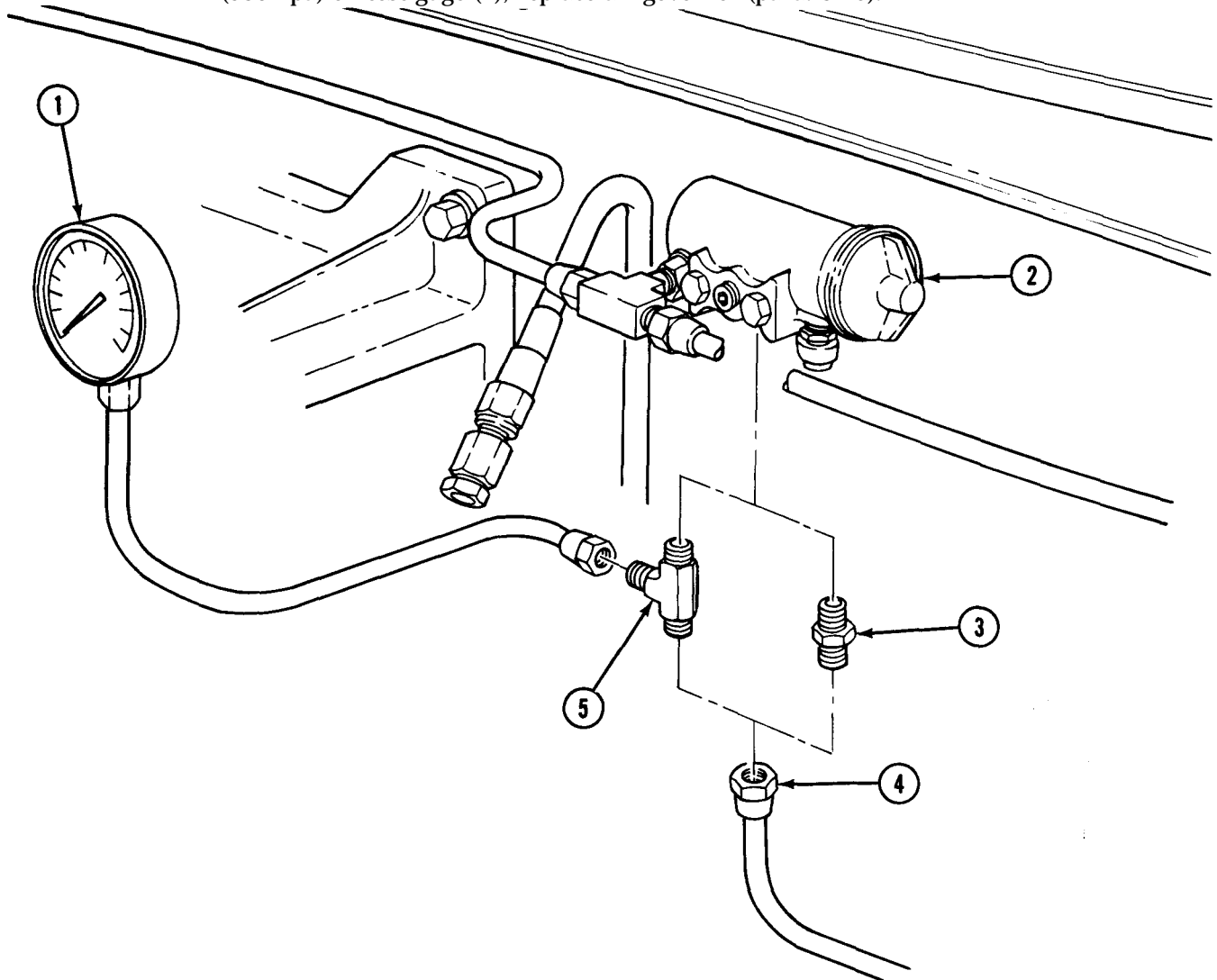

END OF TESTING!

Table 2-3. Compressed Air and Brake System Troubleshooting (Contd).

MALFUNCTION	TEST OR INSPECTION	CORRECTIVE ACTION
-------------	--------------------	-------------------

**12. LOW OR NO READING ON AIR PRESSURE GAGE AND WARNING BUZZER SHUTS OFF**

Test 1. Check air supply pressure to air pressure gage (1).

Step 1. Stop engine and open all draincocks (TM 9-2320-361-10) until brake system air pressure is vented.

Step 2. Disconnect air supply line (2) from air pressure gage adapter (3).

Step 3. Connect air supply line (2) to test gage (4).

Step 4. Start engine (TM 9-2320-361-10) and allow air pressure to build to normal operating pressure.

Step 5. Check test gage (4) reading.

- a. If reading is low or zero, check air supply line (2) for bends, kinks, or leaks. Repair or replace air supply line if bent, kinked, or leaking (para. 8-15).

**NOTE**

Air pressure gage on instrument panel has a maximum pressure scale of 120 psi. If old governor has been replaced with new governor, air pressure may exceed maximum pressure reading on instrument panel gage.

- b. If reading is above 85 psi (586 kPa) on test gage (4), replace air pressure gage (1) (para. 4-11).

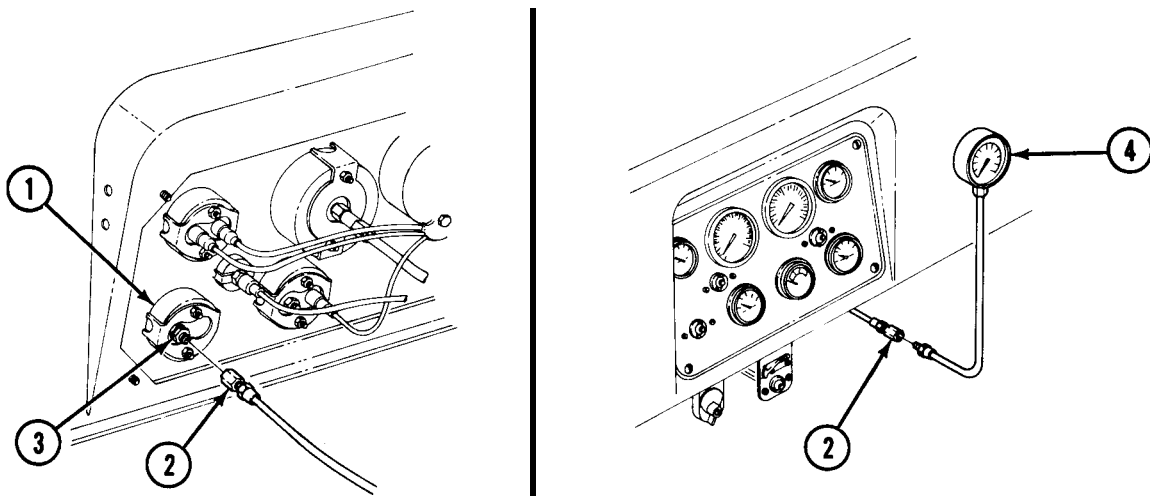

END OF TESTING!

**13. WARNING BUZZER FAILS TO SOUND ON LOW PRESSURE (BELOW 60 PSI)**

Refer to electrical troubleshooting table 2-4.

Table 2-3. Compressed Air and Brake System Troubleshooting (Contd).

MALFUNCTION	TEST OR INSPECTION	CORRECTIVE ACTION
-------------	--------------------	-------------------

**AIR-OPERATED ACCESSORIES**

**14. WINDSHIELD WIPERS INOPERATIVE OR OPERATE SLOWLY (GAGE AT NORMAL OPERATING PRESSURE)**

Step 1. Start engine (TM 9-2320-361-10) and allow air pressure to build to normal operating pressure.

Step 2. Operate windshield wipers and inspect lines and hoses for leaks.

a. If air leaks are found, repair as required.

b. If no air leaks are found, perform test 1.

Test 1. Check windshield wiper motor supply line (9) pressure.

Step 1. Compress clamp (8) and disconnect windshield wiper supply line (9) from tee (7).

Step 2. Install adapter (6) on test gage (5).

Step 3. Connect adapter (6) to windshield wiper supply line (9) with clamp (8).

Step 4. Start engine (TM 9-2320-361-10) and allow air pressure to build to normal operating pressure.

Step 5. Operate windshield wipers to full on position (TM 9-2320-361-10).

Step 6. Check reading on test gage (5).

a. If reading is lower than 55 psi (379 kPa), replace windshield wiper valve (para. 8-19).

b. If reading is 55 psi (379 kPa), perform test 2.

Test 2. Check windshield wiper motor (2) for clogs.

Step 1. Remove clamp (4) and hose (3) from windshield wiper motor (2).

Step 2. Using wire, clean orifice (1) on windshield wiper motor (2).

Step 3. Install hose (3) and clamp (4) on windshield wiper motor (2).

Step 4. Start engine (TM 9-2320-361-10) and allow air pressure to buildup to normal operating pressure.

Step 5. Operate windshield wipers (TM 9-2320-361-10), if windshield wipers are still inoperative, replace defective windshield wiper motor(s) (2) (para. 8-19).

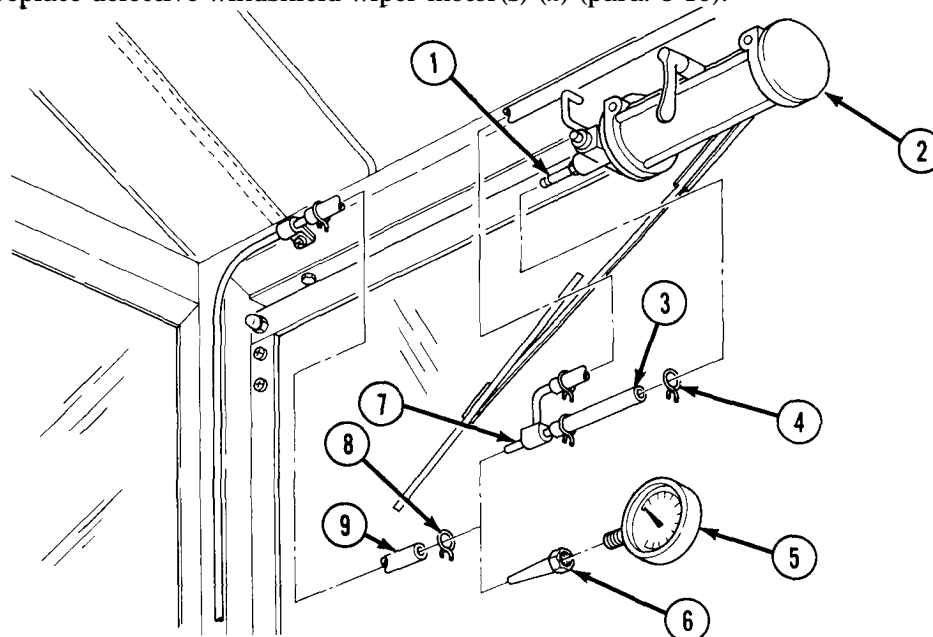

END OF TESTING!

Table 2-3. Compressed Air and Brake System Troubleshooting (Contd).

MALFUNCTION	TEST OR INSPECTION	CORRECTIVE ACTION
-------------	--------------------	-------------------

**15. FRONT WHEEL DRIVE DOES NOT ENGAGE (FRONT WHEEL DRIVE LOCK-IN SWITCH ENGAGED)**

- Step 1. Start engine (TM 9-2320-361-10) and allow air pressure to build to normal operating pressure.
- Step 2. Inspect lines and hoses for air leaks.
  - a. If air leaks are found, repair as required (para. 8-15).
  - b. If no leaks are found, perform test 1.

**Test 1. Check front axle engagement air cylinder supply line (1) pressure.**

- Step 1. Stop engine and open all draincocks (TM 9-2320-361-10) until brake system air pressure is vented.
- Step 2. Disconnect supply line (1) from air cylinder elbow (3).
- Step 3. Remove elbow (3) from air cylinder (2).
- Step 4. Install tee (5) on air cylinder (2).
- Step 5. Connect test gage (4) to tee (5) and connect supply line (1) to tee (5).
- Step 6. Start engine (TM 9-2320-361-10) and allow air pressure to build to normal operating pressure.
- Step 7. Place front wheel drive lock-in switch in ON position.
- Step 8. Check reading on test gage (4) and compare reading to instrument panel air pressure gage.

**NOTE**

Air pressure gage on instrument panel has a maximum pressure scale of 120 psi. If old governor has been replaced with new governor, air pressure may exceed maximum pressure reading on instrument panel gage.

- a. If reading is zero, replace front wheel drive lock-in switch (para. 6-4).
  - b. If reading is lower than instrument panel gage, and air can be heard escaping from transfer case vent, notify your supervisor.
- Step 9. If air system is operating properly, notify your supervisor.

Table 2-3. Compressed Air and Brake System Troubleshooting (Contd).

MALFUNCTION	TEST OR INSPECTION	CORRECTIVE ACTION
-------------	--------------------	-------------------

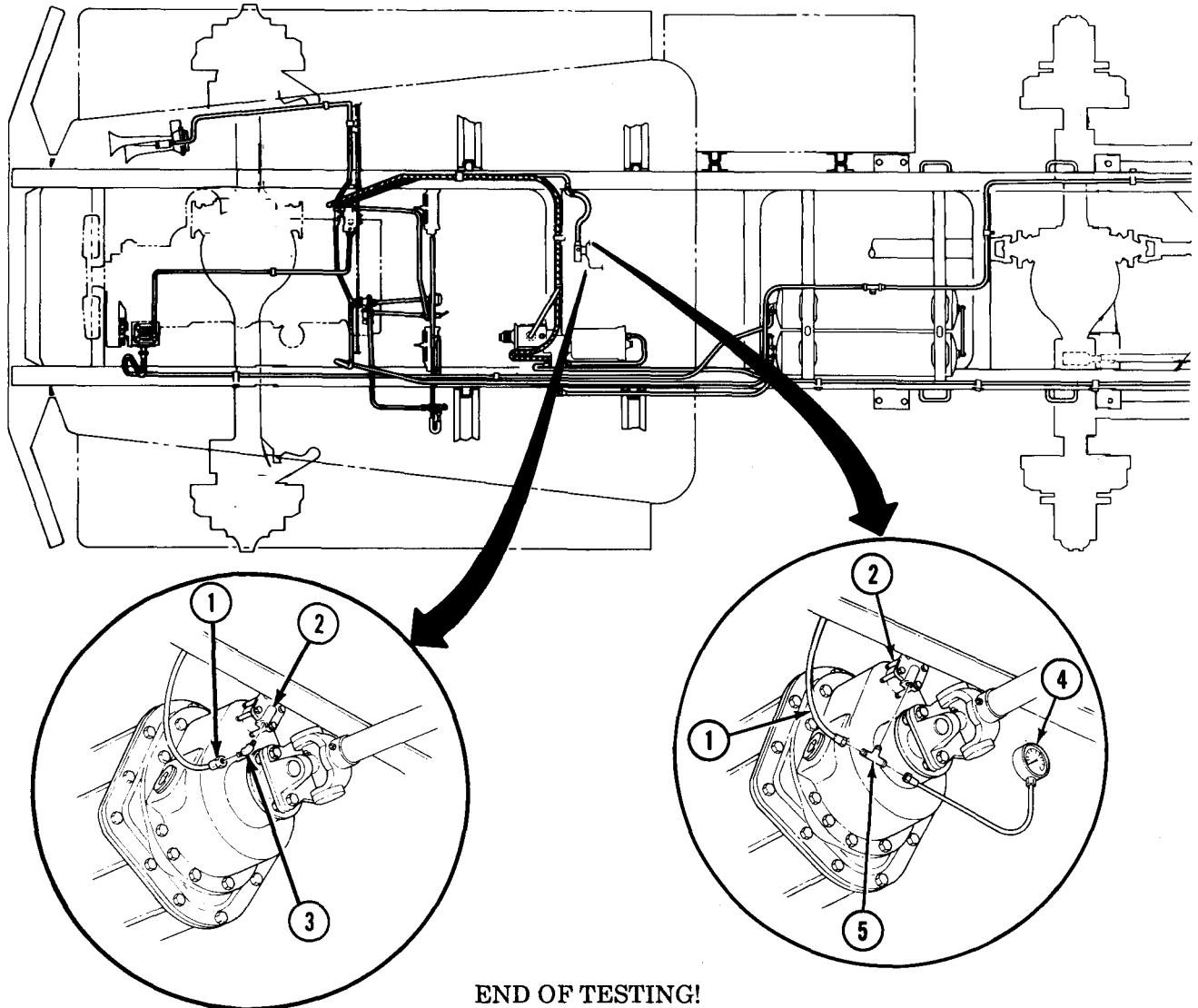

END OF TESTING!

**16. AIR HORN DOES NOT WORK**

Step 1. Refer to electrical troubleshooting malfunction 38.

Step 2. If malfunction still exists, refer to malfunction 9, test 2, steps 1-4.

**NOTE**

Air pressure gage on instrument panel has a maximum pressure scale of 120 psi. If old governor has been replaced with new governor, air pressure may exceed maximum pressure reading on instrument panel gage.

If air pressure reading of test 2 is comparable to air pressure gage on instrument panel, replace air horn (para. 4-31).

END OF TESTING!

## Section VI. ELECTRICAL SYSTEMS TROUBLESHOOTING

### 2-14. GENERAL

a. This section provides information to diagnose and correct malfunctions of the electrical system. Because of its complexity, the electrical system is divided into the following functional systems:

- Battery System (page 2-77)
- Starting System (page 2-79)
- Charging System (60 amp) (page 2-89)
- Charging System (100 amp) (page 2-95)
- Charging System (25 amp) (page 2-98)
- Lighting System (page 2-101)
- Indicators, Gages, and Warning System (page 2-120)
- Heating Systems (page 2-136)
- Trailer Connection System (page 2-146)

b. The wiring schematic (Appendix E) shows the interrelationship of these systems and should be used as a reference when performing electrical troubleshooting (table 2-4).

c. Each malfunction symptom given for an individual component or system is followed by step(s) you should take to determine the cause and corrective action you must take to remedy the problem.

d. Before taking any action to correct a possible malfunction, the following rules should be followed:

(1) Question operator to obtain any information that might help you to determine the cause of the problem.

(2) Never overlook the chance that the problem could be of simple origin. The problem could be corrected with minor adjustment.

(3) Use all senses to observe and locate troubles.

(4) Use test instruments or gages to help you determine and isolate problems.

(5) Always isolate the system where the malfunction occurs and then locate the defective component.

(6) Use standard automotive theories and principles when troubleshooting the vehicles covered in this manual.

e. Table 2-4 lists electrical malfunctions that may occur in individual systems of the vehicle. This table covers electrical troubleshooting only. Troubleshooting procedures for the mechanical systems can be found in table 2-2, section IV.

**2-15. TEST EQUIPMENT**

In troubleshooting the electrical system, multimeters will be used to make resistance or continuity tests and voltage or low ampere current tests. Multimeters may be found in the Common No. 1 and No. 2 Unit Maintenance Automotive Shop Sets.

**ELECTRICAL TROUBLESHOOTING  
SYMPTOM INDEX**

MALFUNCTION NO.	MALFUNCTION	TROUBLESHOOTING PROCEDURE PAGE
<b>BATTERY SYSTEM</b>		
1.	All vehicle electrical systems inoperative . . . . .	2-77
<b>STARTING SYSTEM</b>		
2.	Starter will not crank . . . . .	2-79
3.	Starter motor operates, but engine cranks slowly . . . . .	2-86
<b>CHARGING SYSTEM (60 AMP)</b>		
4.	No alternator output (generator in left-hand red) . . . . .	2-89
5.	Batteries not charging properly (generator in yellow or right-hand red) . . . . .	2-94
6.	Batteries hot or boiling, corrected specific gravity of all cells is 1.280 . . .	2-94
7.	Batteries use excessive water . . . . .	2-94
8.	Batteries run down in operation . . . . .	2-94
<b>CHARGING SYSTEM (100 AMP)</b>		
9.	No alternator output (generator in left-hand red) . . . . .	2-95
10.	Batteries not charging properly (generator in yellow or right-hand red) . . . . .	2-96
11.	Batteries hot or boiling, corrected specific gravity of all cells is 1.280 . . .	2-97
12.	Batteries use excessive water . . . . .	2-97
13.	Batteries run down in operation . . . . .	2-97
<b>CHARGING SYSTEM (25 AMP)</b>		
14.	No generator output (generator in left-hand red). . . . .	2-98
15.	Batteries not charging properly (generator in yellow or right-hand red) . . . . .	2-99
16.	Batteries run down in operation . . . . .	2-99
<b>LIGHTING SYSTEM</b>		
17.	Headlight does not operate on low or high beam, or both headlights inoperative . . . . .	2-101
18.	Front marker lamp does not light . . . . .	2-104
19.	Taillight or clearance lamp does not light . . . . .	2-104
20.	Stoplight lamp does not light . . . . .	2-105
21.	Blackout headlamp does not light . . . . .	2-106
22.	Front blackout marker lamp does not light. . . . .	2-107
23.	Blackout taillight lamp does not light . . . . .	2-108
24.	Blackout stoplight lamp does not light . . . . .	2-109
25.	Direction signal inoperative . . . . .	2-110
26.	All stoplights are inoperative . . . . .	2-116
27.	Both direction signals inoperative . . . . .	2-118
28.	Turn signals operate incorrectly with turn signal control lever in one or more positions . . . . .	2-119



**ELECTRICAL TROUBLESHOOTING  
SYMPTOM INDEX (Contd)**

MALFUNCTION NO.	MALFUNCTION	TROUBLESHOOTING PROCEDURE PAGE
<b>INDICATORS, GAGES, AND WARNING SYSTEM</b>		
29.	All gages inoperative . . . . .	2-121
30.	Engine temperature gage inoperative . . . . .	2-122
31.	Fuel gage inoperative . . . . .	2-124
32.	Oil pressure gage inoperative . . . . .	2-126
33.	Generator gage inoperative . . . . .	2-128
34.	In-tank fuel pump inoperative . . . . .	2-129
35.	Front wheel drive indicator light inoperative . . . . .	2-131
36.	Low air pressure warning system inoperative. . . . .	2-132
37.	Low air pressure warning system does not come on below 60 psi and does not go off above 66 psi. . . . .	2-133
38.	Horn does not operate . . . . .	2-134
<b>HEATING SYSTEMS</b>		
39.	Engine manifold heater does not work. . . . .	2-136
40.	Hot water personnel heater does not operate or does not operate in low position . . . . .	2-142
41.	Personnel fuel burning heater inoperative . . . . .	2-144
42.	Heater control box light inoperative, but heater operative . . . . .	2-146
<b>TRAILER CONNECTION SYSTEM</b>		
43.	One or more trailer lights inoperative . . . . .	2-146

**BATTERY SYSTEM**

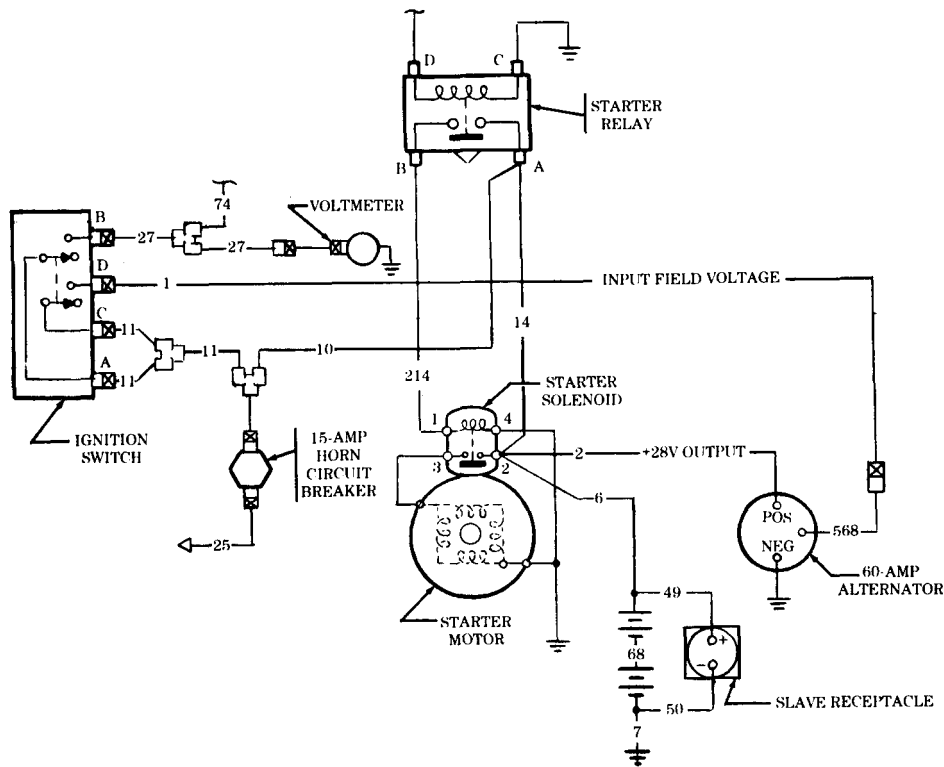

Table 2-4. Electrical Troubleshooting.

MALFUNCTION	TEST OR INSPECTION	CORRECTIVE ACTION
-------------	--------------------	-------------------

**BATTERY SYSTEM**

**1. ALL VEHICLE ELECTRICAL SYSTEMS INOPERATIVE**

**WARNING**

- Battery acid (electrolyte) is extremely harmful. Always wear safety goggles and rubber gloves when performing battery maintenance. Severe injury will result if acid contacts eyes or skin.
- Do not smoke, have open flame, or make sparks when performing battery maintenance. Batteries may explode causing severe injury to personnel.
- Remove all jewelry such as rings, dog tags, bracelets, etc. If jewelry or disconnected battery ground cable contacts battery positive post, a direct short can result, causing damage to equipment or severe injury to personnel.
- When removing battery cables, disconnect ground cable first. Do not allow tools to come in contact with vehicle when disconnecting cable clamps. A direct short can result, causing instant heating of tools, tool damage, battery damage, or battery explosion, and severe injury to personnel.

**CAUTION**

- During installation of battery terminals, ensure positive clamps are installed on positive (+) posts and negative clamps are installed on negative (-) posts. Failure to connect clamps to correct posts will reverse polarity of circuitry and may cause damage to rectifier diodes in alternator, vehicle wiring, and radios (if equipped).
- Do not use a hammer during installation of battery terminal. Spread battery terminal open, or damage to equipment may result.

Step 1. Open door of battery compartment. Loosen two thumbscrews and slide batteries onto running board. Visually check connections of battery cables.

Ensure battery cables are correctly connected to batteries (para. 4-48).

Step 2. Visually check batteries for cracks and leaks. Check terminal posts for corrosion and breaks (TM 9-6140-200-14).

- Replace any battery that is cracked, leaking, or has broken terminal posts (para. 4-49).
- If terminal posts or cable clamps are corroded, use soda and water solution to neutralize battery acid. Remove battery ground cable no. 7 from negative post first. Remove cable clamps from battery posts, clean posts, and clamp mating surfaces to bright metal.
- If battery terminals are clean and malfunction still exists, go to test 1.

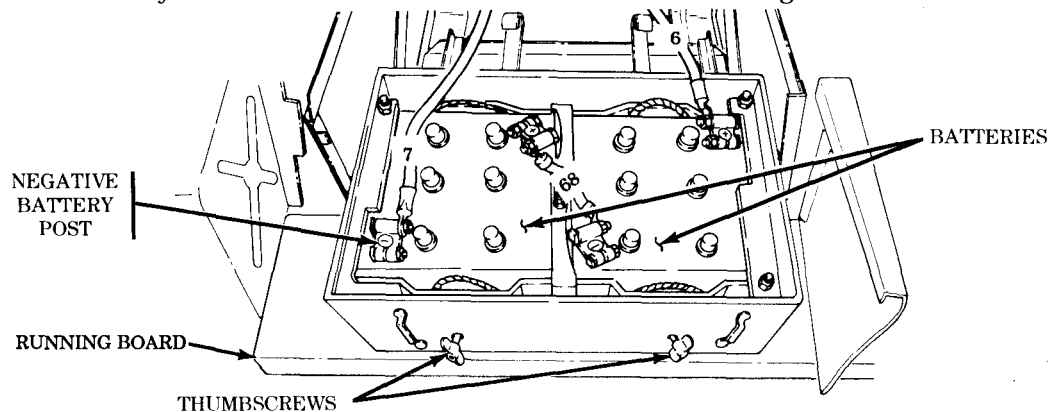

Table 2-4. Electrical Troubleshooting (Contd).

MALFUNCTION	TEST OR INSPECTION	CORRECTIVE ACTION
-------------	--------------------	-------------------

Test 1. Check specific gravity of each cell before adding distilled water.

Step 1. Using optical battery tester, which requires no temperature compensation, check specific gravity of electrolyte in each cell (TM 9-6140-200-14).

If specific gravity of any cell is below 1.225, battery must be replaced or recharged. Add distilled water as necessary after checking battery. Charge battery as necessary (TM 9-6140-200-14).

Step 2. Check specific gravity of cells after battery has been charged (TM 9-6140-200-14).

a. If specific gravity of any cell does not increase to 1.280 (full charge) in 25 hours of charging, replace battery (para. 4-49).

b. Each cell in a battery must test within 0.025 points of each other. If specific gravity of any cell is lower than 1.255 [corrected to 80°F (27°C) if necessary] after 25 hours of charging, replace battery (para. 4-49).

Test 2. Disconnect battery ground cable (para. 4-48) and test battery cables as follows:

Step 1. Set multimeter to RX1 scale.

Step 2. Check for continuity of battery cables no. 6 and 68 and for worn or frayed insulation.

a. If resistance is greater than 1 ohm, replace or repair battery cables (para. 4-48 or 4-51).

b. If insulation is worn or frayed, replace or repair battery cables (para. 4-48 or 4-51).

Step 3. Check continuity of battery ground cable no. 7 to frame ground.

a. If resistance measures greater than 1 ohm, clean cable no. 7 connection at right-hand frame rail.

b. If continuity is still greater than 1 ohm, replace or repair battery cable (para. 4-48 or 4-51).

Step 4. Connect battery ground cable (para. 4-48) and proceed to test 3.

Test 3. Check for battery voltage at starter solenoid.

Step 1. Set multimeter to a voltage range that will measure 24 Vdc.

Step 2. Check lead no. 6 at contact 2 of starter solenoid for battery voltage.

If battery voltage is not present, clean connections of lead no. 6 at contact no. 2 of starter solenoid.

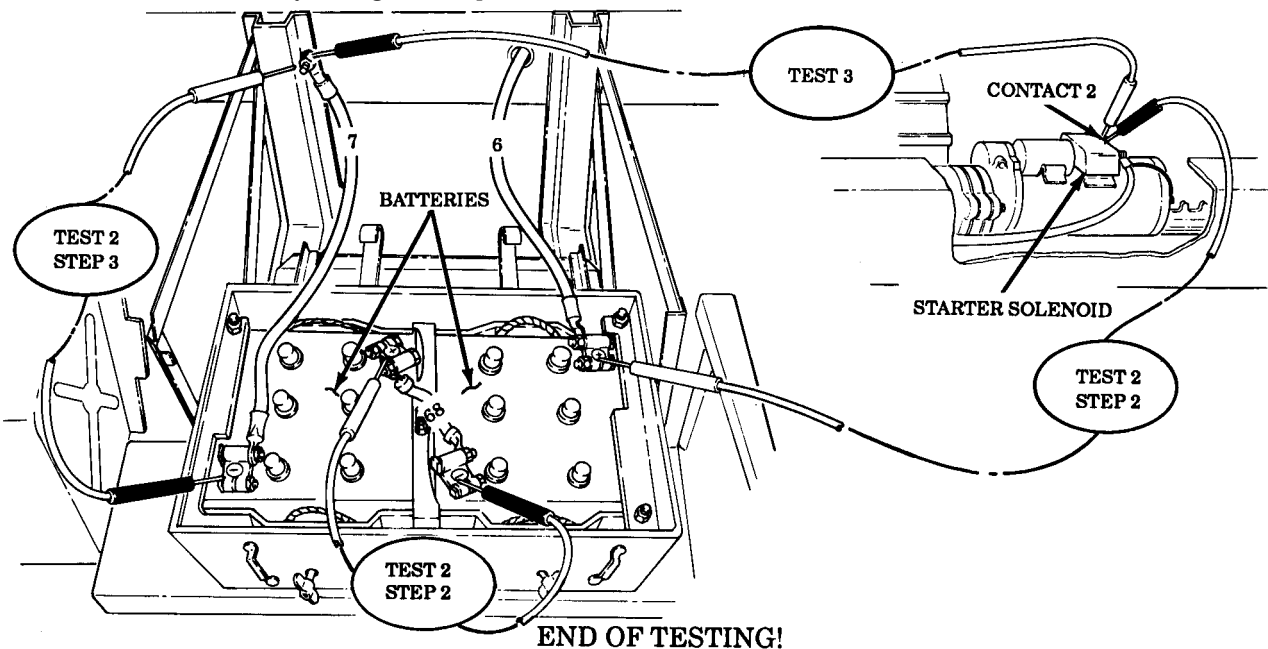
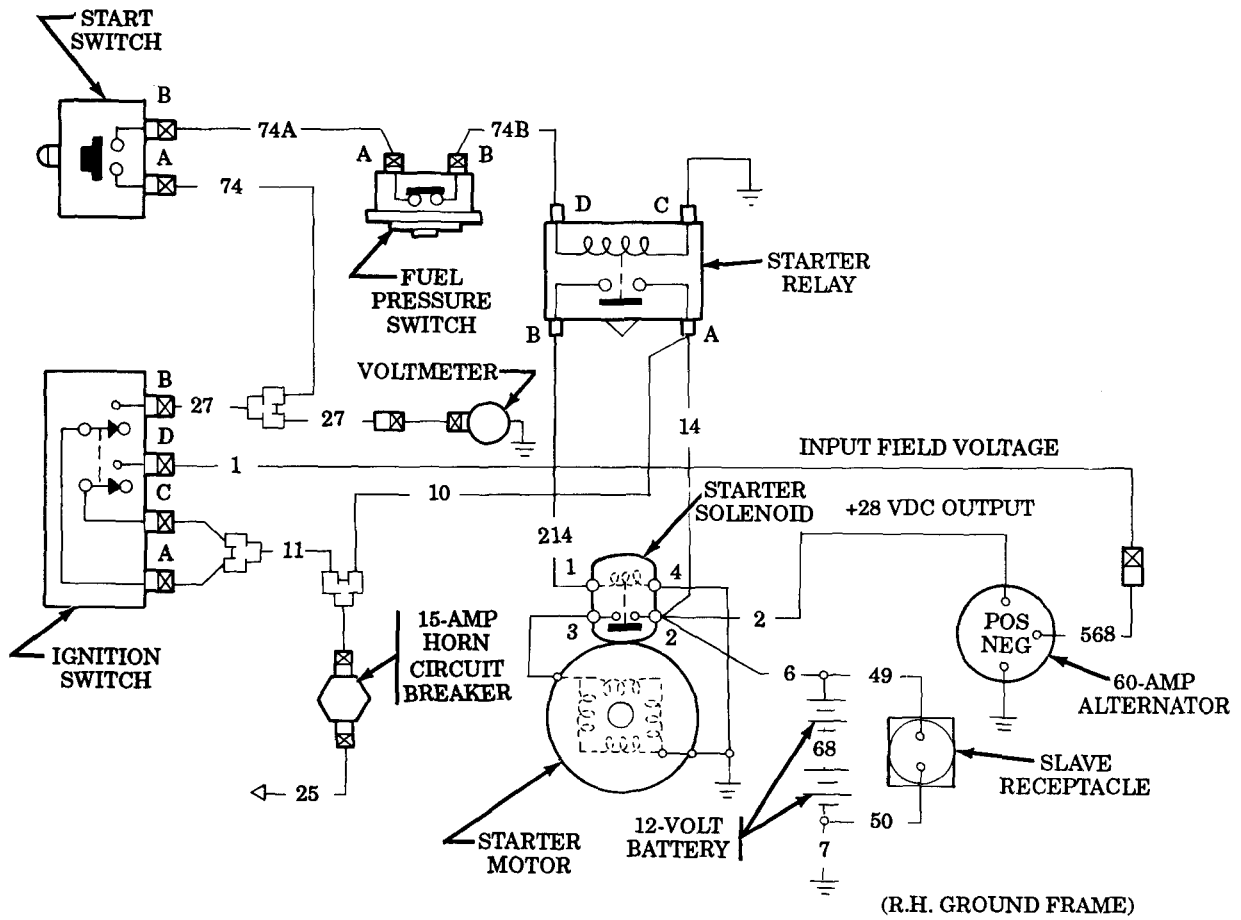

Table 2-4. Electrical Troubleshooting (Contd).

MALFUNCTION	TEST OR INSPECTION	CORRECTIVE ACTION
-------------	--------------------	-------------------

STARTING SYSTEM



STARTING SYSTEM

2. STARTER WILL NOT CRANK

NOTE

Ensure transmission is in neutral.  
Check batteries and cables (malfunction 1).

Table 2-4. Electrical Troubleshooting (Contd).

MALFUNCTION	TEST OR INSPECTION	CORRECTIVE ACTION
-------------	--------------------	-------------------

Test 1. Test for battery voltage at pin 1 of starter solenoid with accessory/ignition switch turned to ON position.

Step 1. Push start button and listen for starter solenoid to create a “thump” sound when energized.

- a. If “thump” sound is heard, go to step 2.
- b. If “thump” sound is not heard, go to step 3.

Step 2. Check lead 6 at starter solenoid for battery voltage.

- a. Check for seized engine. Refer to table 2-2, Mechanical Troubleshooting, malfunction 1, step 3.
- b. If voltage is present but less than 19 Vdc, check for corrosion and/or loose connections.
- c. If engine is not seized, replace starter motor (para. 4-7).
- d. If no voltage is present and engine still fails to start, go to step 3.

Step 3. Check lead 214 for battery voltage at pin 1 of starter solenoid.

- a. If voltage is not present, go to test 2.
- b. If voltage is present and solenoid does not engage starter motor, proceed to step 4.

Step 4. Set multimeter to RX1 scale. Check continuity between pin 4 of starter solenoid and frame ground.

- a. If continuity is greater than 1 ohm, remove starter solenoid and starter motor ground cables (para. 4-7). Replace or repair cables (para. 4-48 or 4-51) that have resistance greater than 1 ohm. Clean cable ends. Clean connections on starter motor and frame ground. Reconnect ground cables and ensure all connections are tight. Repeat test 1, step 1.
- b. If continuity is greater than 1 ohm, starter solenoid is defective. Replace starter motor (para. 4-7).

Step 5. Check battery cables for voltage drop (malfunction 3, tests 4 through 7).

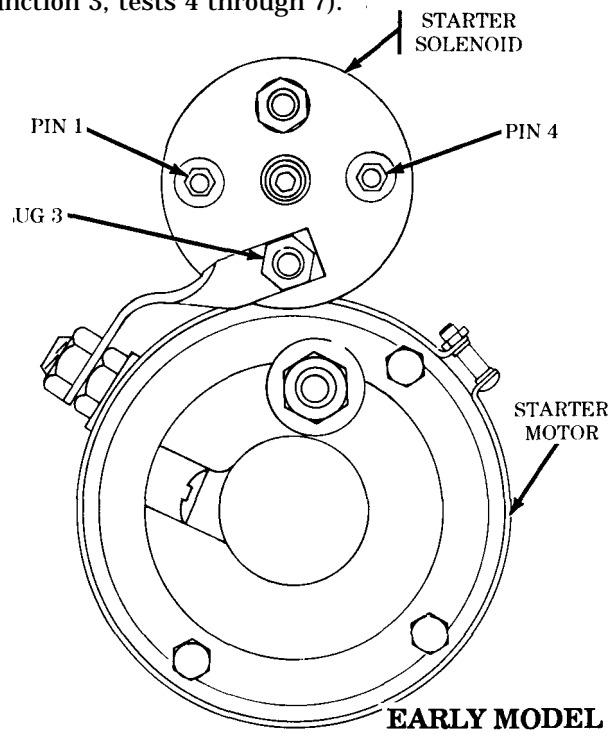
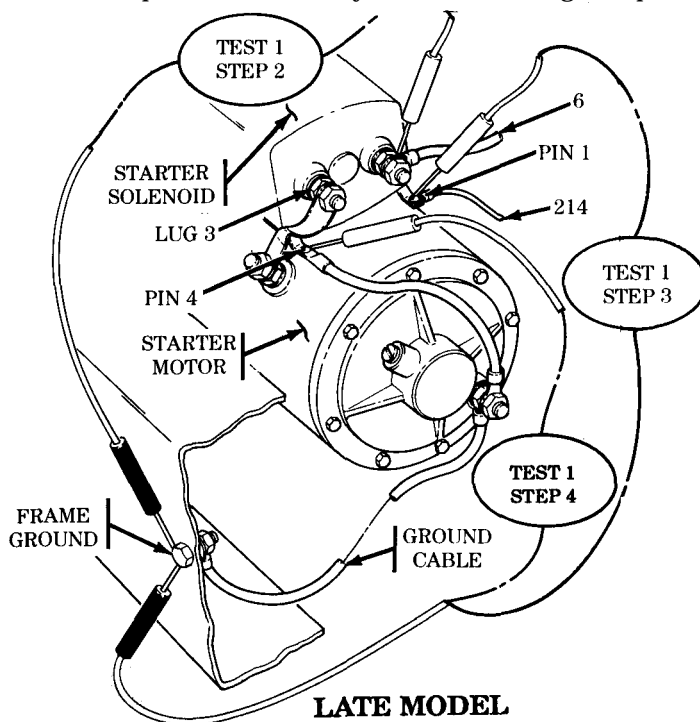

Table 2-4. Electrical Troubleshooting (Contd).

MALFUNCTION	TEST OR INSPECTION	CORRECTIVE ACTION
-------------	--------------------	-------------------

Test 2. Test for battery voltage at lug D of magnetic starter relay.

- Step 1. With accessory/ignition switch ON, push start switch and at same time check for battery voltage at lug D on starter relay.
  - a. If 19 Vdc are not present, go to test 4.
  - b. If voltage is present, go to step 2.
- Step 2. Set multimeter to RX1 scale. Check continuity between lug C on starter relay and ground.
  - a. If continuity is 1 ohm or less, go to step 3.
  - b. If continuity is greater than 1 ohm, disconnect ground lead at lug C. Repair or replace ground lead (para. 4-51). Go to test 1, step 1.
- Step 3. Check for battery voltage at lug B of starter relay with start switch PUSHED.
  - a. If voltage is present, go to step 5.
  - b. If voltage is not present, go to step 4.
- Step 4. Check for battery voltage at lug A on starter relay. Voltage should always be present. If voltage is not present, replace or repair lead 14 (para. 4-51). Go to test 1, step 1 and retest.
- Step 5. Check continuity of lead 214 between lug B on starter relay and pin 1 on starter solenoid. If continuity is not present, replace or repair lead 214 (para. 4-51). Clean connections before reinstalling lead. Ensure all connections are tight. Go to test 1, step 1 and retest.

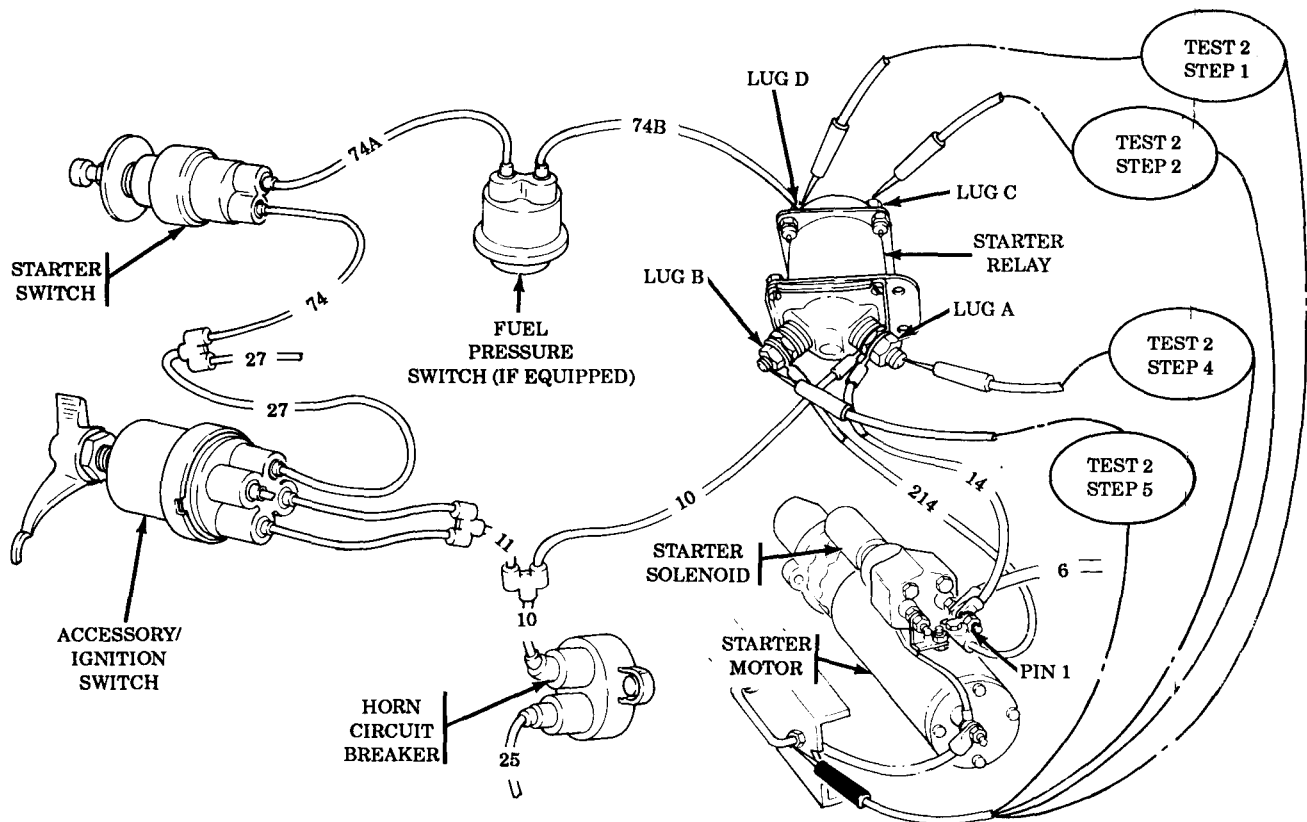

Table 2-4. Electrical Troubleshooting (Contd).

MALFUNCTION	TEST OR INSPECTION	CORRECTIVE ACTION
-------------	--------------------	-------------------

**NOTE**

M44A2 series vehicles may not be equipped with fuel pressure switch. If vehicle is not equipped with fuel pressure switch, starter switch output circuit would be wired directly to starter relay.

Test 3. Test for battery voltage on fuel pressure switch with accessory/ignition switch turned ON.

Step 1. Remove lead 74A from pin A of fuel pressure switch, push start button, and check for battery voltage.

- a. If voltage is not present, go to test 4.
- b. If voltage is present, go to step 2.

Step 2. Disconnect battery ground cable (para. 4-48), remove lead 74B from pin B of fuel pressure switch, and check continuity from lead 74B contact end to lug D on starter relay.

- a. If no continuity is present, repair or replace lead 74B (para. 4-51).
- b. If continuity is present, go to step 3.

Step 3. Check continuity of fuel pressure switch. With engine stopped, fuel pressure will be off and contacts of switch will be closed. These normally closed contacts will be opened when engine is running.

If no continuity is present between pins A and B, replace fuel pressure switch (para. 4-37) and go to test 1, Step 1.

Test 4. Test for battery voltage into accessory/ignition switch pins A and C.

Step 1. Remove two leads 11 from accessory/ignition switch pins A and C. Using multimeter, check for battery voltage on contact ends of leads 11.

- a. If voltage is not present, go to test 5
- b. If voltage is present, install both leads 11 into pins A and C and go to step 2.

Step 2. Observe voltmeter in dash for proper operation (TM 9-2320-361-10).

- a. If voltmeter works, go to step 5.
- b. If voltmeter does not work, go to step 3.

Step 3. Remove lead 27 from pin B of accessory/ignition switch. With accessory/ignition switch turned ON, check for battery voltage at pin B.

- a. If voltage is present, go to step 5.
- b. If voltage is not present, go to step 4.

Step 4. Remove leads 11 from pins A and C and lead 1 from pin D. With accessory/ignition switch in ON position, check continuity between pins A and B followed by pins C and D.

- a. If continuity is not found, replace accessory/ignition switch (para. 4-21). Check continuity of new accessory/ignition switch before installation. Reinstall leads 11 in pins A and C. Reinstall lead 27 in pin B and lead 1 in pin D. Attempt to start engine (TM 9-2320-361-10).
- b. If starter does not crank engine, go to step 5.

Step 5. Remove lead 74A from pin B of START switch. With accessory/ignition switch in ON position, push start switch, and check for battery voltage at pin B.

- a. If voltage is not present, go to step 6.
- b. If voltage is present, perform continuity check on lead 74A.
- c. If no continuity is present, replace or repair lead (para. 4-51).

Table 2-4. Electrical Troubleshooting (Contd).

MALFUNCTION	TEST OR INSPECTION	CORRECTIVE ACTION
-------------	--------------------	-------------------

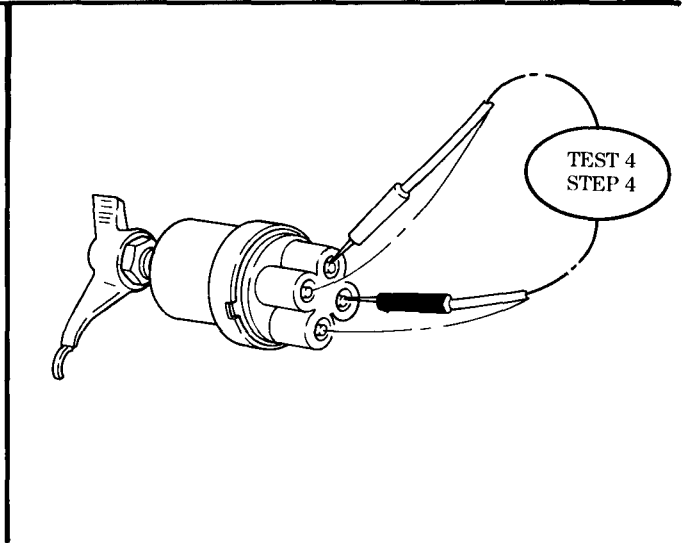
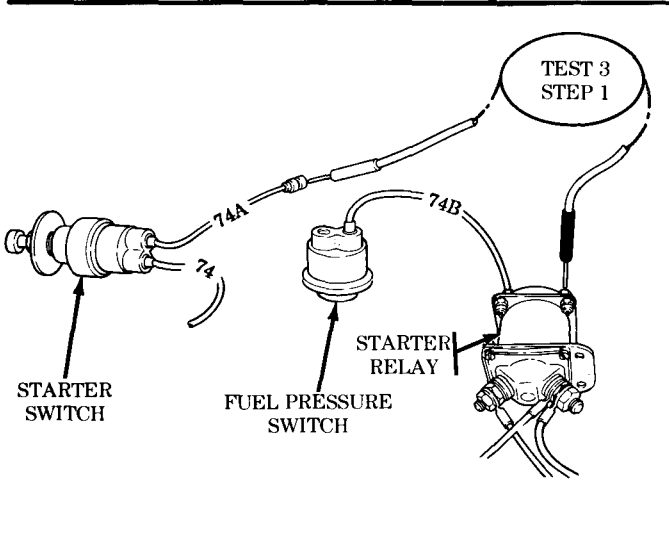
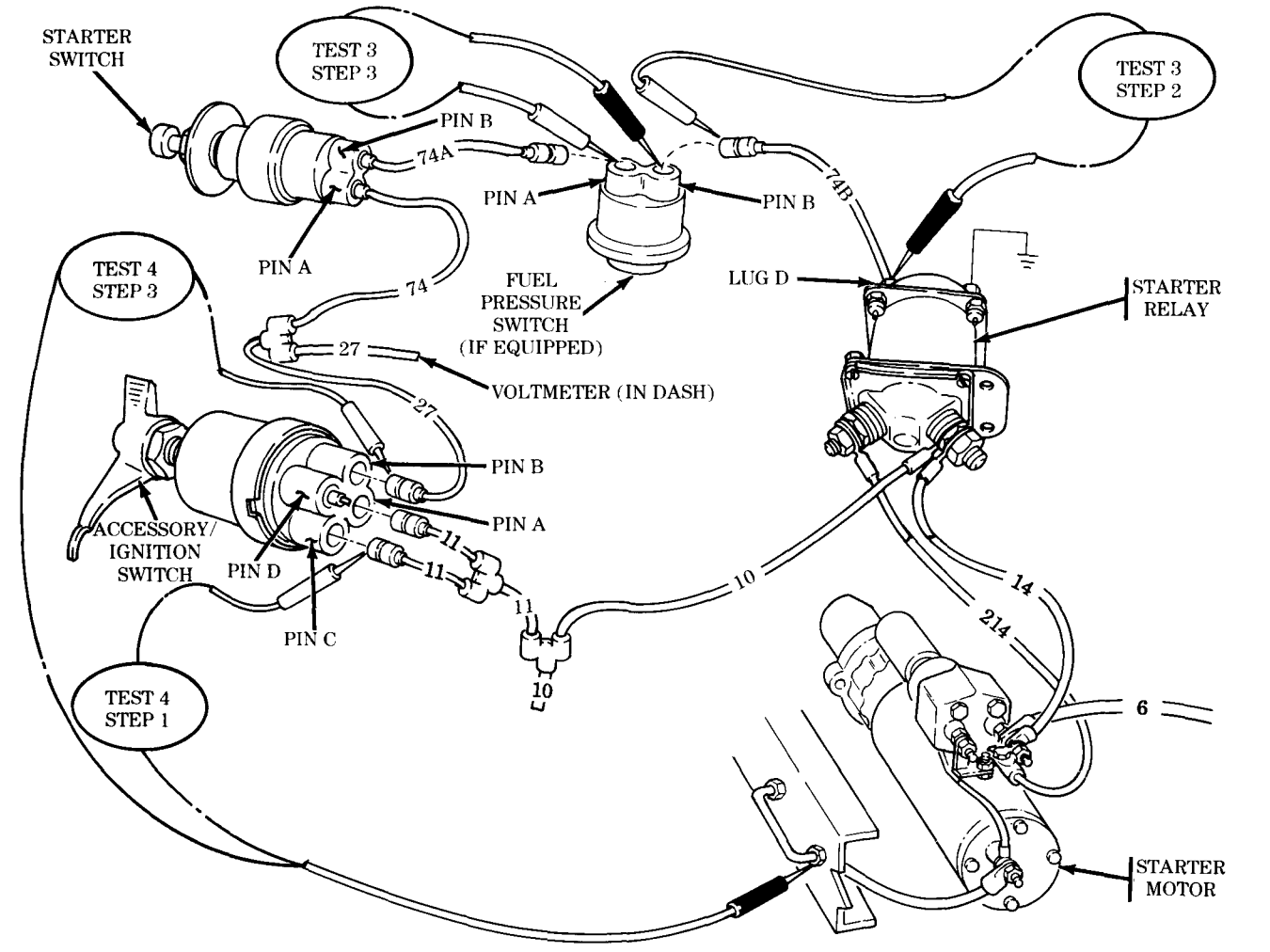



Table 2-4. Electrical Troubleshooting (Contd).

MALFUNCTION	TEST OR INSPECTION	CORRECTIVE ACTION
-------------	--------------------	-------------------

- Step 6. Remove lead 74 from pin A of start switch, turn accessory/ignition switch to ON position, and check for battery voltage on contact end of lead 74.
- If voltage is not present, disconnect lead 27 from accessory/ignition switch and check continuity between lead 27 and its connection to lead 74.
  - If continuity is not found, replace or repair lead (para. 4-51). Reinstall lead 74 into pin A.
- Step 7. Attempt to start engine (TM 9-2320-361-10).  
If starter does not engage engine, go to step 8.
- Step 8. Remove lead 74 from pin A and lead 74A from pin B of start switch. Push start switch and perform continuity check between pins A and B.
- If continuity is not found, replace start switch (para. 4-8).
  - Check continuity of new switch before installation.
  - Reinstall lead 74A in pin B and lead 74 in pin A.
  - Push start switch. Starter should turn engine.

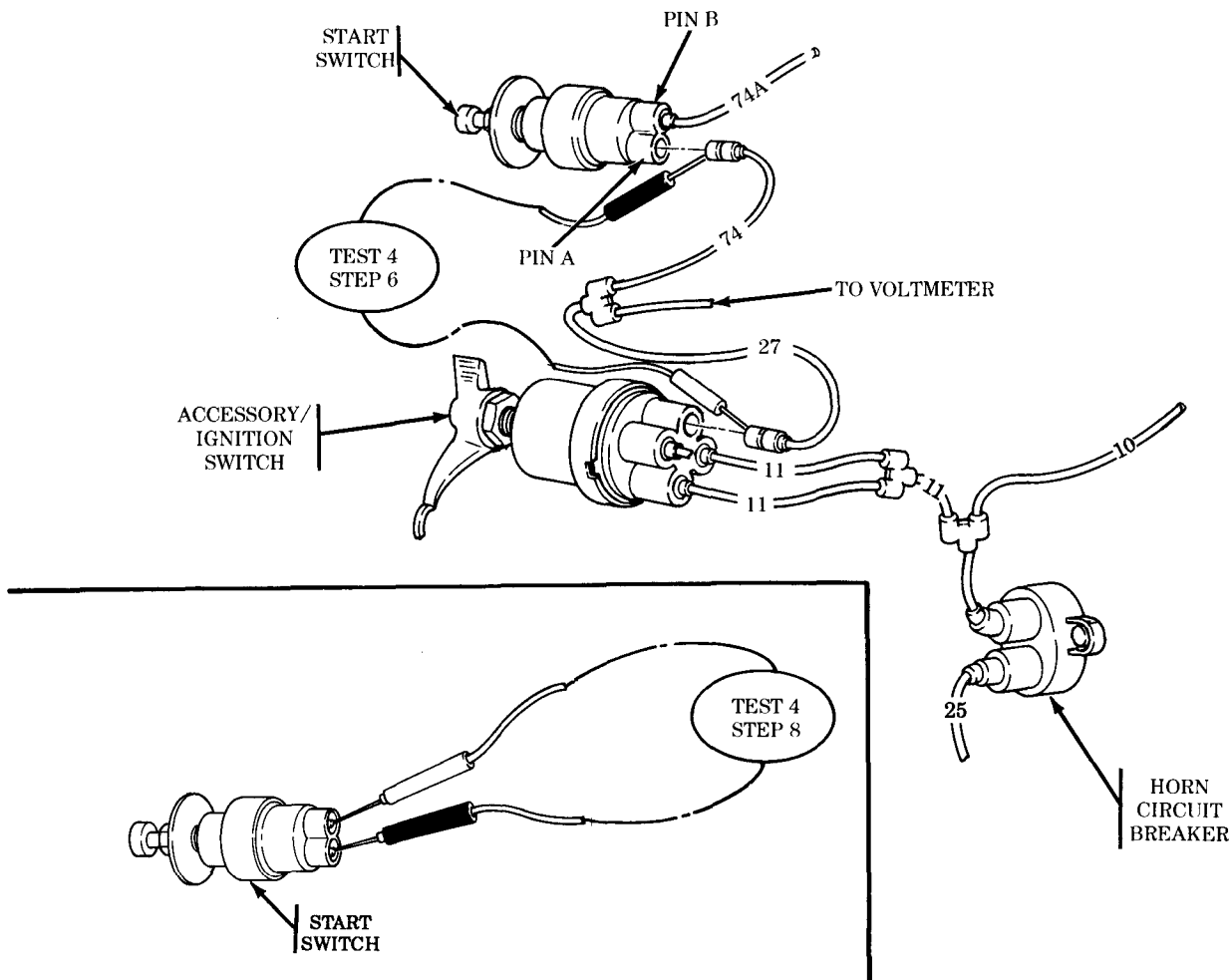

Table 2-4. Electrical Troubleshooting (Contd).

MALFUNCTION	TEST OR INSPECTION	CORRECTIVE ACTION
-------------	--------------------	-------------------

Test 5. Check for battery voltage at horn circuit breaker.

Step 1. Remove lead 10 from horn circuit breaker and check for battery voltage on contact end.

- a. If battery voltage is not present, go to step 2.
- b. If battery voltage is present, go to step 3.

Step 2. Disconnect battery ground cable (para. 4-48). Disconnect two leads 11 from accessory/ignition switch and check continuity of two leads 11 and lead 10.

- a. If continuity is not present, repair or replace leads 11 or lead 10 (para. 4-51).
- b. If continuity is present, reconnect two leads 11, lead 10, and battery ground cable (para. 4-48). Go to step 3.

Step 3. With accessory/ignition switch ON, push start switch. Starter should engage engine flywheel and crank engine.

If starter does not engage flywheel and crank engine, return to test 4, step 2.

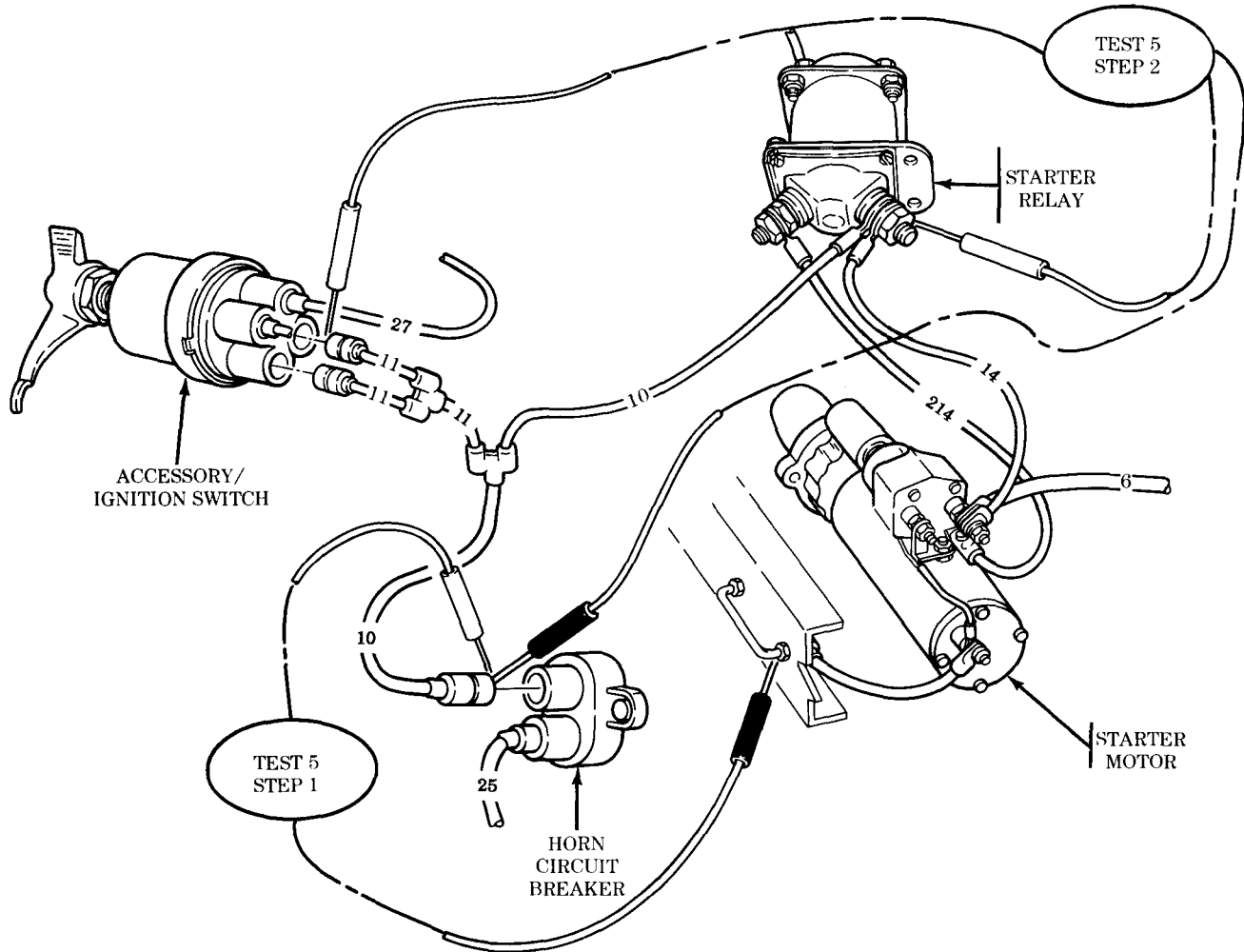

END OF TESTING!

Table 2-4. Electrical Troubleshooting (Contd).

MALFUNCTION	TEST OR INSPECTION	CORRECTIVE ACTION
-------------	--------------------	-------------------

**3. STARTER MOTOR OPERATES, BUT ENGINE CRANKS SLOWLY**

**NOTE**

If STE/ICE is available, perform NG80 - starter circuit tests (chapter 2, section VII).

Test 1. Check batteries for overheating by cranking engine for 15 seconds and feeling battery terminal connections.

If battery terminal is hot, a loose or corroded connection is indicated.

- a. Clean corroded connection to bright metal.
- b. Tighten all loose connections at batteries, ground, and starter.

Test 2. Test specific gravity for each battery.

Perform a specific gravity test (TM 9-6140-200-14), Batteries must test 1.255 or greater, temperature corrected, and each cell in a battery must test within 0.025 points of the others.

- a. Charge all batteries not meeting requirements (TM 9-6140-200-14) and check specific gravity again.
- b. If 0.025 point variation still exists within any battery, it is defective and must be replaced (para. 4-49).

Test 3. Test starter motor voltage.

Step 1. Set multimeter to a voltage range that will measure 24 Vdc.

Step 2. Connect multimeter positive lead to positive terminal lug 6 of starter motor and negative lead to terminal lug 5 on end plate of starter motor.

Step 3. Crank engine (TM 9-2320-361-10) and observe cranking voltage on multimeter. Voltage should exceed 19 Vdc.

If voltage is less than 19 Vdc, clean and tighten starter motor connections.

Test 4. Test starter motor-to-solenoid strap voltage drop.

Step 1. Set multimeter to a voltage range that will measure tenths of a volt.

Step 2. Connect multimeter negative lead to positive terminal lug 6 of starter motor and multimeter positive lead to starter motor solenoid terminal lug 3.

Step 3. Crank engine (TM 9-2320-361-10) and observe multimeter. A voltage reading exceeding 0.2 volts indicates a bad connection at starter motor terminal lug 3 and terminal lug 6 of solenoid.

Clean and tighten connections.

Test 5. Test starter motor solenoid contact voltage drop.

Step 1. Set multimeter to a voltage range that will measure tenths of a volt.

Step 2. Connect multimeter between starter motor solenoid terminal lugs 3 and 2.

Step 3. Crank engine (TM 9-2320-361-10) and observe multimeter. A voltage reading exceeding 0.4 volts indicates a defective starter motor solenoid.

a. Replace starter motor and solenoid assembly (para. 4-7).

b. If malfunction still exists, go to tests 6, 7, and 8.

Test 6. Test negative cable 7 voltage drop from batteries to starter motor.

Step 1. Set multimeter to voltage range that will measure tenths of a volt.

Step 2. Connect multimeter positive lead to terminal stud on end plate of starter motor and negative lead to frame ground.

Step 3. Crank engine (TM 9-2320-361-10) and observe multimeter. A voltage reading exceeding 0.4 volts indicates a defective starter motor solenoid.

a. Replace starter motor and solenoid assembly (para. 4-7).

b. If malfunction still exists, go to tests 7 and 8.

Table 2-4. Electrical Troubleshooting (Contd).

MALFUNCTION	TEST OR INSPECTION	CORRECTIVE ACTION
-------------	--------------------	-------------------

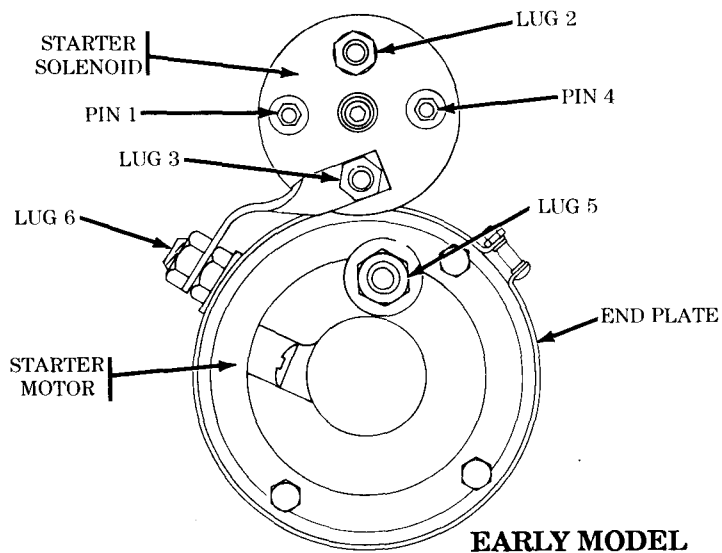
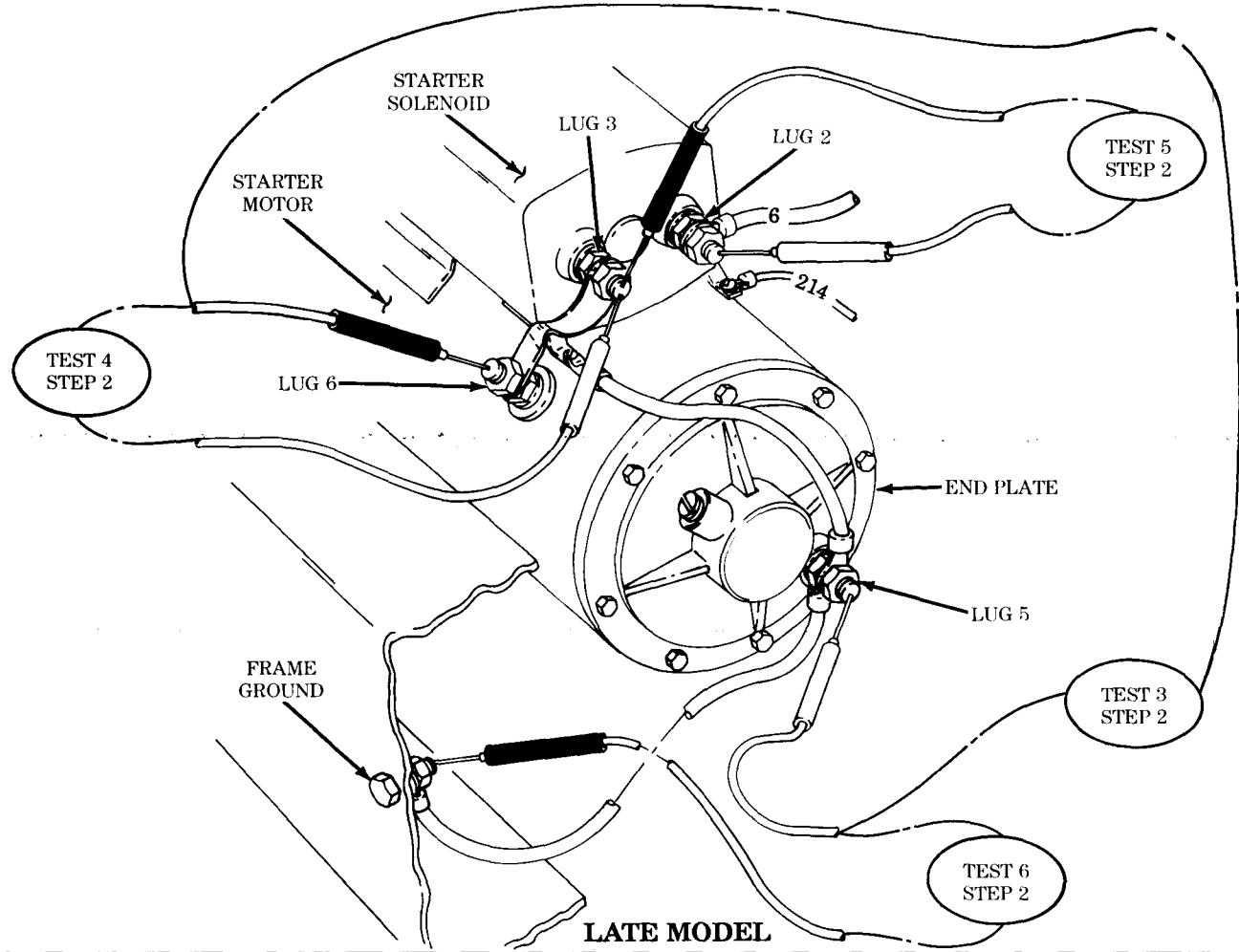

Table 2-4. Electrical Troubleshooting (Contd).

MALFUNCTION	TEST OR INSPECTION	CORRECTIVE ACTION
-------------	--------------------	-------------------

Test 7. Test positive cable 6 voltage drop from batteries to starter motor solenoid.

Step 1. Set multimeter to a voltage range that will measure tenths of a volt.

Step 2. Connect multimeter positive lead to positive terminal post on batteries and negative lead to lug 2 on starter motor solenoid.

Step 3. Crank engine (TM 9-2320-361-10) and observe multimeter. A voltage reading exceeding 0.4 volts indicates a loose or corroded connection.

Clean and tighten cable connections at batteries, starter, and chassis (para. 4-48).

Test 8. Test battery voltage while cranking engine.

Step 1. Set multimeter to a voltage range that will measure 24 Vdc.

Step 2. Connect multimeter directly across battery terminal posts, positive lead to positive post, and negative lead to negative post.

Step 3. With emergency engine stop handle pulled (TM 9-2320-361-10), crank engine for 30 seconds (TM 9-2320-361-10). Voltage reading should be 19 Vdc or more during cranking.

a. If battery voltage is not satisfactory, go to malfunction 1 and check battery.

b. If battery voltage is satisfactory, replace starter motor and solenoid assembly (para. 4-7).

Step 4. Disengage emergency stop handle (TM 9-2320-361-10).

If engine still cranks slowly, notify your supervisor.

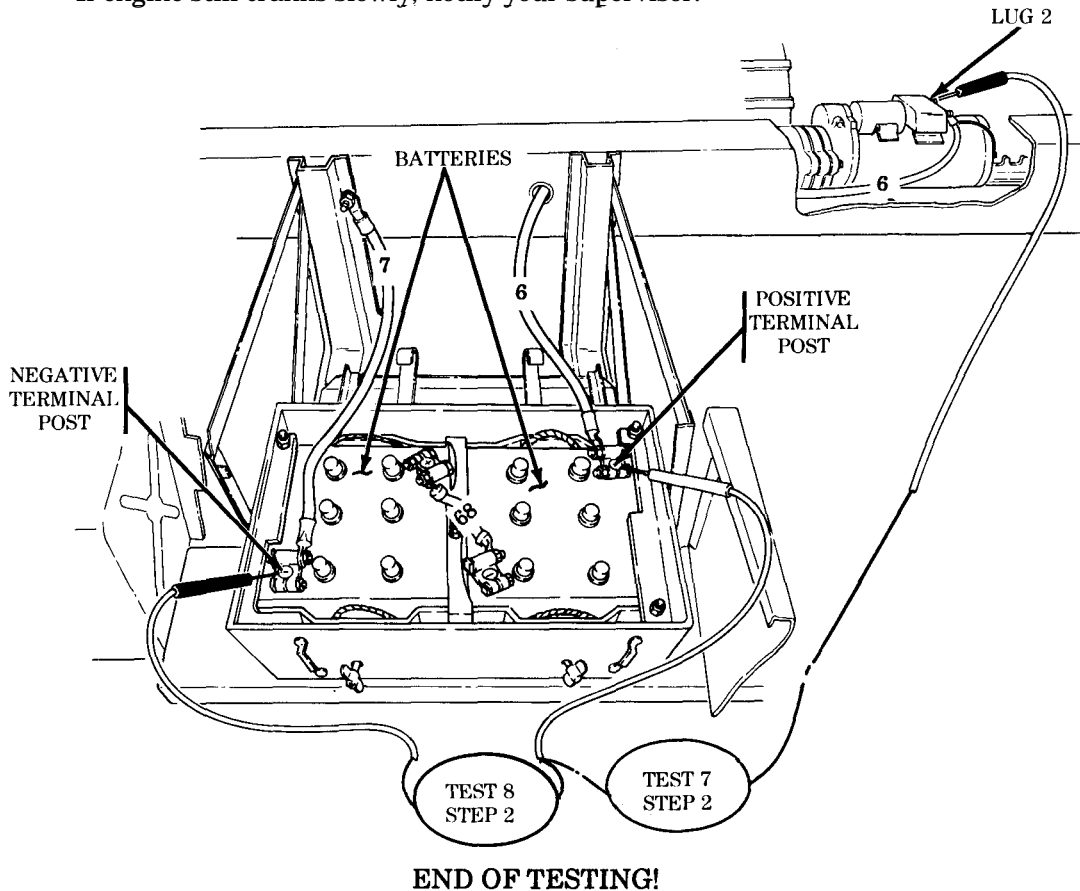
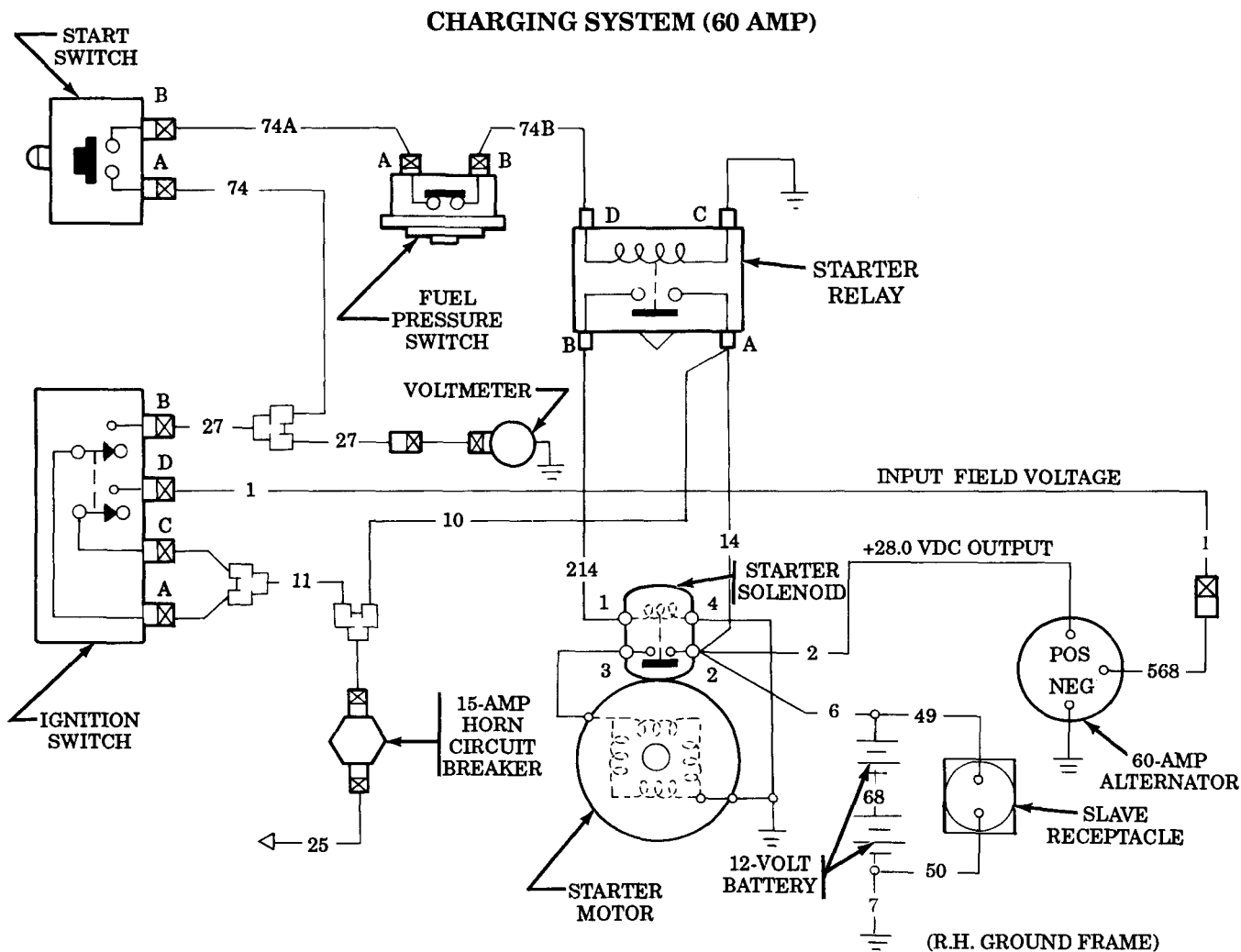

Table 2-4. Electrical Troubleshooting (Contd).

MALFUNCTION	TEST OR INSPECTION	CORRECTIVE ACTION
-------------	--------------------	-------------------



**CHARGING SYSTEM (60 AMP)**

**4. NO ALTERNATOR OUTPUT (GENERATOR IN LEFT-HAND RED)**

**NOTE**

- Voltage regulator is built into alternator.
- If STE/ICE is available, perform NG50 - charging circuit tests (chapter 2, section VII).

Test 1. Check for loose or missing belts.

- a. Adjust loose belts (para. 4-2).
- b. Replace missing belts (para. 4-2).

Table 2-4. Electrical Troubleshooting (Contd).

MALFUNCTION	TEST OR INSPECTION	CORRECTIVE ACTION
-------------	--------------------	-------------------

Test 2. Test charging system output voltage.

Step 1. Open door of battery compartment. Loosen two thumbscrews and slide batteries onto running board.

Step 2. Use multimeter to check battery voltage.

**NOTE**

If vehicle is equipped with a slave receptacle, check voltage at receptacle.

Step 3. Start engine (TM 9-2320-361-10).

Step 4. Set engine speed at 1200 rpm.

Step 5. Turn vehicle headlights and accessories to ON position.

Step 6. Use multimeter to check battery voltage. Charging voltage on batteries should be  $28.0 \pm 0.2$  Vdc.

- a. If battery voltage measures 24.0 Vdc, alternator has no output. Go to test 3 and check input voltage.
- b. If battery voltage is between 24.0 and 26.0 Vdc, alternator output is weak. Go to test 3 and check input voltage.
- c. If battery voltage measures  $28.0 \pm 0.2$  Vdc and battery generator on instrument panel shows no voltage, an electrical problem exists between generator and accessory/ignition switch. Go to malfunction 2, test 4, step 3.
- d. If battery voltage measures between 26.0 and 30.0 Vdc, adjust voltage regulator (para. 4-3) in alternator until voltage across batteries is  $28.0 \pm 0.2$  Vdc. Go to step 7 and check regulator stability.
- e. If regulator voltage across batteries cannot be adjusted to  $28.0 \pm 0.2$  Vdc, replace alternator (para. 4-3).
- f. If battery voltage is greater than 30.0 Vdc, first try to adjust voltage regulator in alternator down to 28.0 Vdc. If voltage regulator voltage cannot be adjusted to 28.0 Vdc, replace alternator (para. 4-3).

Step 7. Check voltage regulator stability as follows:

- a. Decrease engine speed to 1000 rpm with headlights in ON position. Regulated battery voltage should remain at  $28.0 \pm 0.2$  Vdc.
- b. If battery voltage drops below 27.5 Vdc, replace alternator (para. 4-3).
- c. Increase engine speed to 2000 rpm. Regulated battery voltage should remain at  $28.0 \pm 0.2$  Vdc.
- d. If battery voltage increases above 28.5 Vdc, replace alternator (para. 4-3).
- e. Return engine speed to 1200 rpm.
- f. Turn headlights OFF and ON and observe change of battery voltage.
- g. If battery voltage changes more than  $\pm 0.5$  Vdc and does not return quickly to  $28.0 \pm 0.2$  Vdc, replace alternator (para. 4-3).

Table 2-4. Electrical Troubleshooting (Contd).

**MALFUNCTION  
TEST OR INSPECTION**

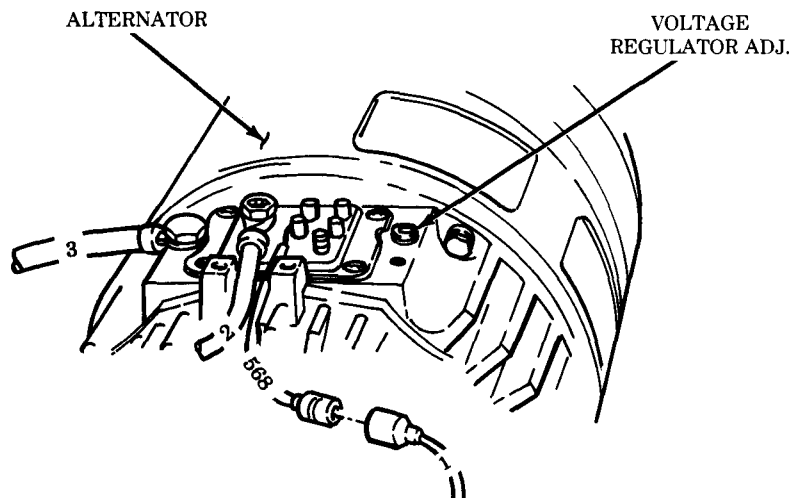
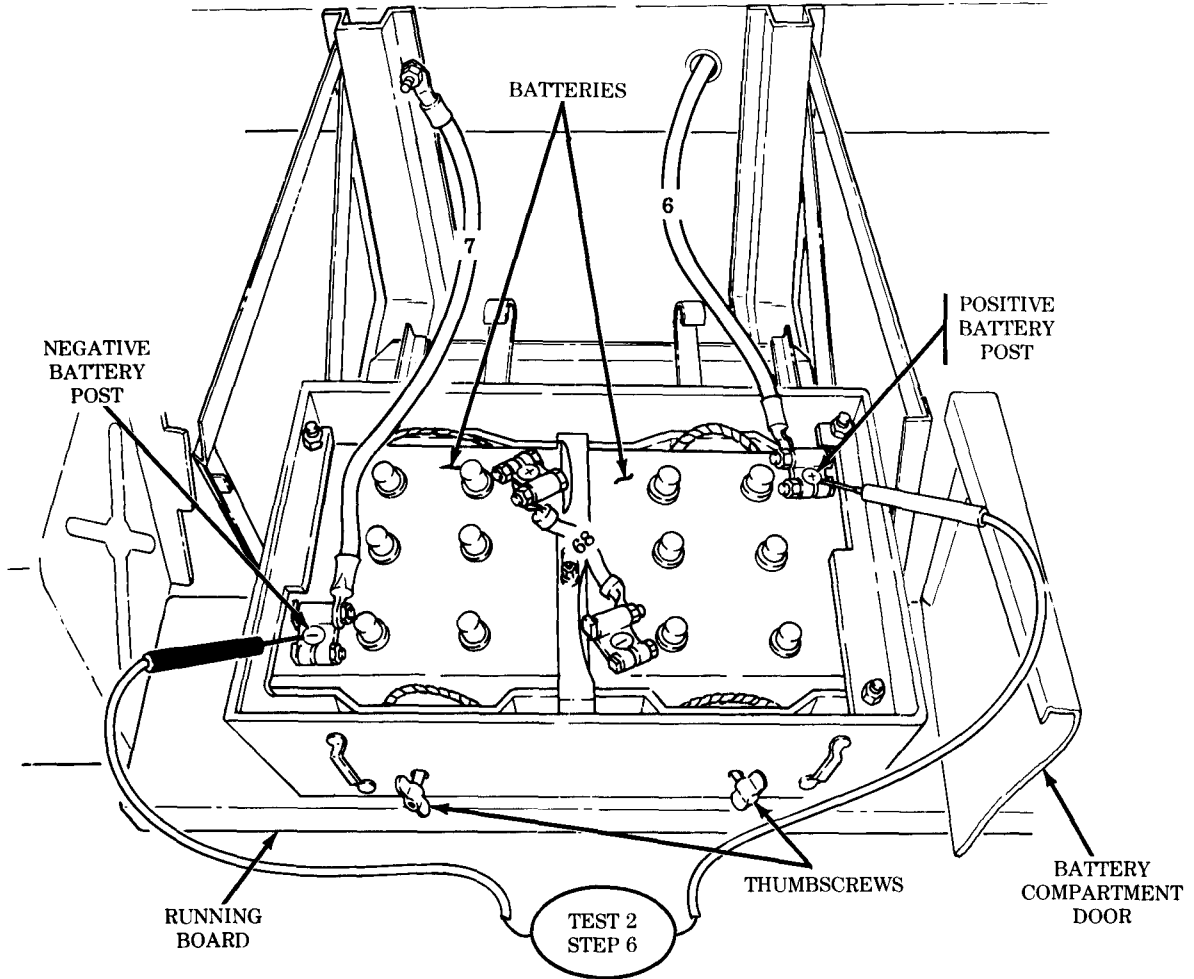



Table 2-4. Electrical Troubleshooting (Contd).

MALFUNCTION	TEST OR INSPECTION	CORRECTIVE ACTION
-------------	--------------------	-------------------

Test 3. Test input voltage to alternator.

Step 1. Turn headlights to OFF position. Stop engine.

Step 2. Disconnect lead 1 from lead 568 at alternator.

Step 3. Turn accessory/ignition switch to ON position.

Step 4. Check for battery voltage at contact end of lead 1. Voltage should be 24.0 Vdc.

- a. If voltage is not present, an open lead or bad connection exists in input circuit. Go to test 6.
- b. If voltage is 24.0 Vdc (normal), remove access cover on top of alternator to expose output terminals.
- c. Reconnect lead 1 to lead 568. Go to step 5.

Step 5. Measure voltage at terminal end of lead 568.

- a. If battery voltage is present (normal), the alternator is believed to be defective. Go to test 4 and check positive output of alternator.
- b. If voltage is not present, an open lead or bad contact exists in lead 568. Repair or replace lead (para. 4-51), return to test 2.

Test 4. Test positive output of alternator.

**NOTE**

- Access cover has been removed in test 3.
- IA decrease in input voltage normally causes an increase in alternator output voltage.

Step 1. Start engine (TM 9-2320-361-10).

Step 2. Set engine speed at 1200 rpm.

Step 3. Turn headlights and accessories to ON position.

Step 4. Use multimeter and measure alternator output voltage at positive terminal (lead 2).

- a. If output voltage is between 24.0 and 26.0 Vdc, replace alternator (para. 4-3).
- b. If output voltage is more than 28.5 Vdc, go to test 5 and check voltage drop on lead 2.

Test 5. Test voltage drop on lead 2.

Step 1. Place multimeter positive lead on alternator positive output. Place multimeter negative lead on starter solenoid lug 2.

Step 2. If voltage drop on lead 2 is greater than 0.4 volts, replace or repair lead (para. 4-51). Go to test 2.

Step 3. If voltage drop on lead 2 is less than 0.4 volts (normal), voltage regulator output is too high. Replace alternator (para. 4-3).

Test 6. Test battery voltage into accessory/ignition switch (malfunction 2, test 4).

Step 1. Disconnect lead 1 from pin D of accessory/ignition switch.

Step 2. Turn accessory/ignition switch to ON position.

Step 3. Check voltage at pin D of accessory/ignition switch. Battery voltage should be present.

- a. If battery voltage is present, go to step 4 and check continuity of lead 1.
- b. If voltage is not present, perform malfunction 2, test 4, step 4, to test continuity of accessory/ignition switch.
- c. If continuity is present in accessory ignition switch, go to step 4.

Table 2-4. Electrical Troubleshooting (Contd).

MALFUNCTION	TEST OR INSPECTION	CORRECTIVE ACTION
-------------	--------------------	-------------------

Step 4. With both ends of lead 1 disconnected, check continuity.

- a. If continuity is present, reconnect lead 1 to pin D of accessory/ignition switch. With accessory/ignition switch in ON position, battery voltage should be present at lead 1.
- b. If continuity is not present, replace or repair lead 1 (para. 4-51).

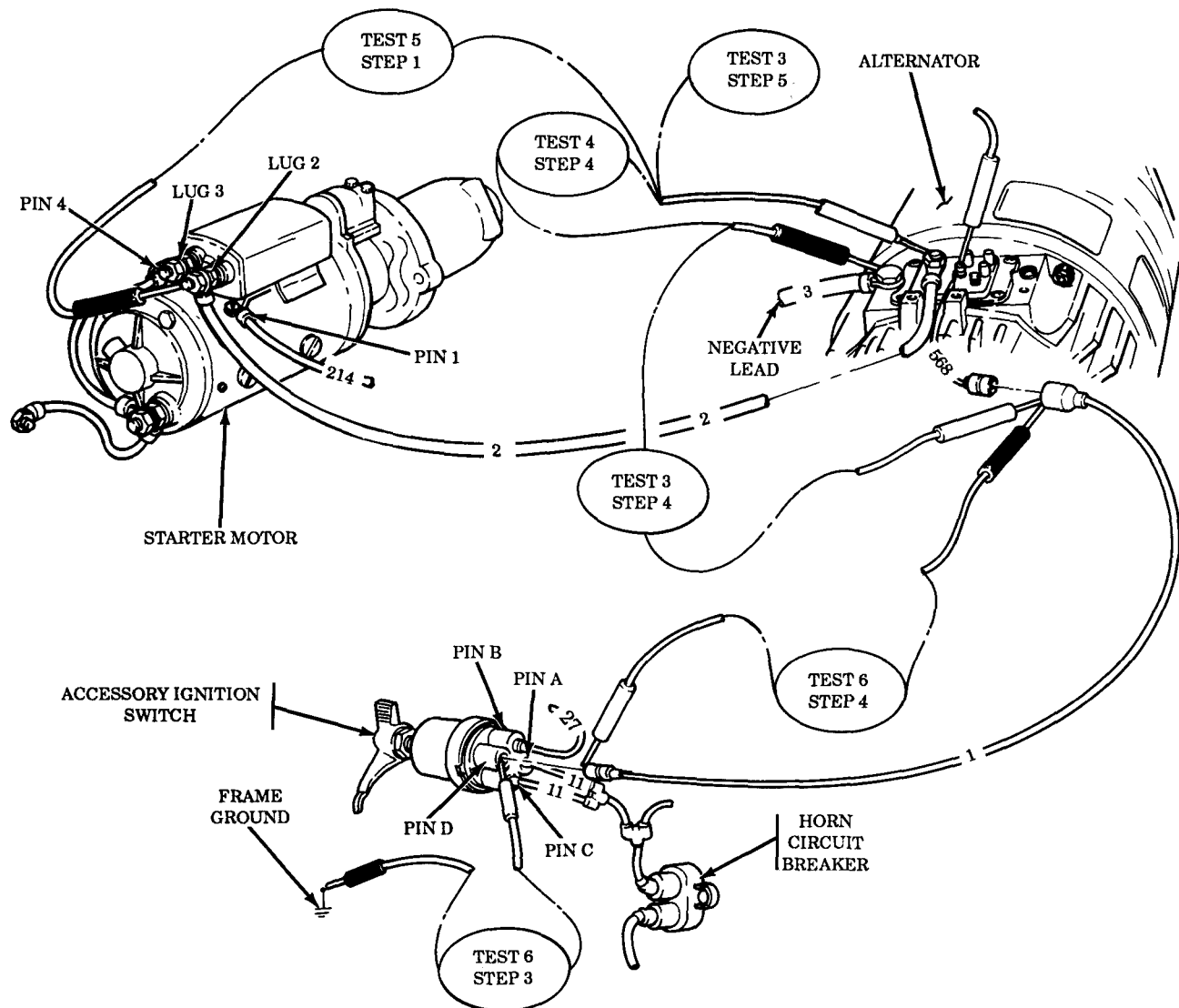

END OF TESTING!

Table 2-4. Electrical Troubleshooting (Contd).

MALFUNCTION	TEST OR INSPECTION	CORRECTIVE ACTION
-------------	--------------------	-------------------

**5. BATTERIES NOT CHARGING PROPERLY (GENERATOR IN YELLOW OR RIGHT-HAND RED)**

**NOTE**

If STE/ICE is available, perform NG50 - charging circuit tests (chapter 2, section VII).

Test 1. Check for loose or missing alternator belts.

- a. Adjust loose belts (para. 4-2).
- b. Replace broken or missing belts (para. 4-2).

Test 2. Test battery voltage.

**NOTE**

Battery voltmeter located on instrument panel is not always accurate and should not be used to adjust voltage. Indicator needle in voltmeter located on instrument panel should cover the white dot at edge of green area when battery voltage is  $28.0 \pm 0.2$  Vdc.

If voltage across batteries cannot be adjusted to  $28.0 \pm 0.2$  Vdc, go to malfunction 4, test 3 and check voltage.

END OF TESTING!

**6. BATTERIES HOT OR BOILING, CORRECTED SPECIFIC GRAVITY OF ALL CELLS IS 1.280**

**NOTE**

If STE/ICE is available, perform NG50 - charging circuit tests (chapter 2, section VII).

Test charging voltage (malfunction 4, test 2).

END OF TESTING!

**7. BATTERIES USE EXCESSIVE WATER**

**NOTE**

If STE/ICE is available, perform NG81 - battery tests or NG50 - charging circuit tests (chapter 2, section VII).

Test charging voltage (malfunction 4, test 2).

END OF TESTING!

**8. BATTERIES RUN DOWN IN OPERATION**

**NOTE**

If STE/ICE is available, perform NG50 - charging circuit tests (chapter 2, section VII).

Test 1. Check for loose or missing alternator belts.

- a. Adjust loose belts (para. 4-2).
- b. Replace missing belts (para. 4-2).

Test 2. Test charging voltage (malfunction 4, test 2).

**NOTE**

If proper voltage is indicated, problem is not in charging system. Refer to battery system troubleshooting (malfunction 1).

END OF TESTING!

Table 2-4. Electrical Troubleshooting (Contd).

MALFUNCTION	TEST OR INSPECTION	CORRECTIVE ACTION
-------------	--------------------	-------------------

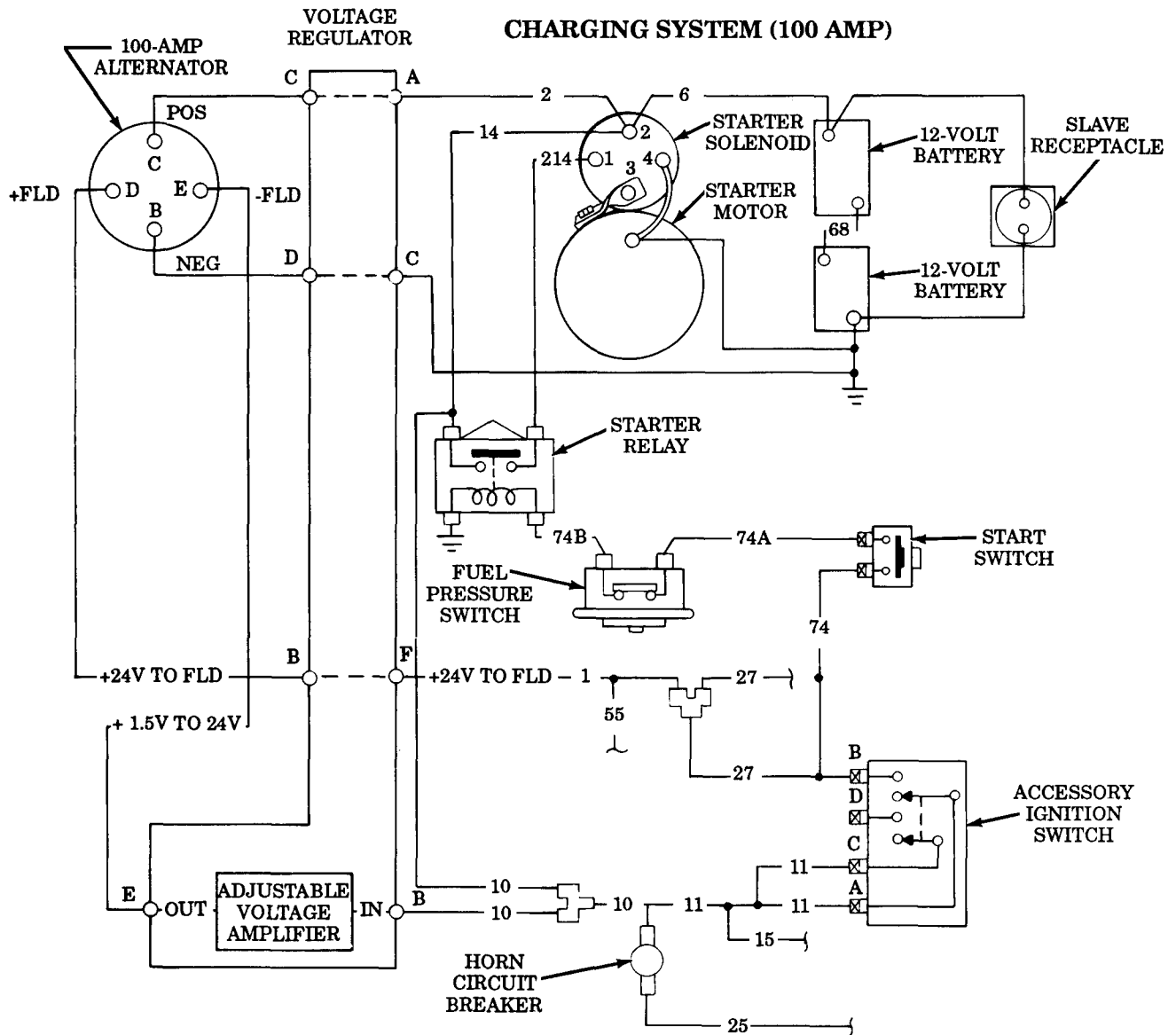

CHARGING SYSTEM (100 AMP)

9. NO ALTERNATOR OUTPUT (GENERATOR IN LEFT-HAND RED)

NOTE

If STE/ICE is available, perform NG50 - charging circuit test (chapter 2, section VII).

Test 1. Check for loose or missing belts.

- a. Adjust loose belts (para. 4-2).
- b. Replace missing belts (para. 4-2).

Table 2-4. Electrical Troubleshooting (Contd).

MALFUNCTION	TEST OR INSPECTION	CORRECTIVE ACTION
-------------	--------------------	-------------------

Test 2. Test charging system output voltage.

**NOTE**

- Voltage regulators in both the 100 amp and 60 amp charging systems regulate battery voltage to  $28.0 \pm 0.2$  Vdc.
- The 100 amp voltage regulator is separate from the 100 amp alternator.
- Battery voltage fluctuations are not to go above 28.5 Vdc or less than 27.5 Vdc as headlights are turned ON, OFF, and ON with engine running at 1200 rpm.
- For test purposes only, charging voltage across batteries can be varied between 26.0 to 30.0 Vdc with engine running at 1200 rpm and headlights off.

- Step 1. Turn off engine.
- Step 2. Open door of battery compartment. Loosen two thumbscrews and slide batteries onto running board.
- Step 3. Use multimeter to check battery for voltage.
- Step 4. Start engine (TM 9-2320-361-10).
- Step 5. Set engine speed at 1200 rpm.
- Step 6. Turn ON vehicle headlights and accessories.
- Step 7. Use multimeter to check battery voltage. Normal charging voltage on batteries is  $28.0 \pm 0.2$  Vdc.

**CAUTION**

Do not puncture waterproof covering on cable between alternator and voltage regulator to make voltage checks. The cable will be unserviceable.

- a. If battery voltage measures between 24.0 and 26.0 Vdc and alternator has no or very weak output. Replace alternator (para. 14-50).
  - b. If battery voltage measures between 26.0 to 30.0 Vdc. adjust voltage regulator (if equipped with adjustment screw). If charging voltage across batteries cannot be adjusted to  $28.0 \pm 0.2$  Vdc, replace voltage regulator (para. 14-52). If charging voltage across batteries can be adjusted to  $28.0 \pm 0.2$  Vdc, go to step 8.
- Step 8. Check voltage regulator stability.  
Go to malfunction 4, test 2, step 7.

END OF TESTING!

**10. BATTERIES NOT CHARGING PROPERLY (GENERATOR IN YELLOW OR RIGHT-HAND RED)**

**NOTE**

If STE/ICE is available, perform NG50 - charging circuit tests (chapter 2, section VII).

- Test 1. Check for loose or missing alternator belts.
- a. Adjust loose belts (para. 4-2).
  - b. Replace broken or missing belts (para. 4-2).

Table 2-4. Electrical Troubleshooting (Contd).

MALFUNCTION	TEST OR INSPECTION	CORRECTIVE ACTION
-------------	--------------------	-------------------

Test 2. Test battery voltage.  
Go to malfunction 9, test 2.

END OF TESTING!

**11. BATTERIES HOT OR BOILING, CORRECTED SPECIFIC GRAVITY OF ALL CELLS IS 1.280**

**NOTE**

If STE/ICE is available, perform NG50 - charging circuit tests (chapter 2, section VII).

Test charging voltage (malfunction 9, test 2).

END OF TESTING!

**12. BATTERIES USE EXCESSIVE WATER**

**NOTE**

If STE/ICE is available, perform NG50 - charging circuit tests (chapter 2, section VII).

Test charging voltage (malfunction 9, test 2).

END OF TESTING!

**13. BATTERIES RUN DOWN IN OPERATION**

**NOTE**

If STE/ICE is available, perform NG50 - charging circuit tests (chapter 2, section VII).

Test 1. Check for loose or missing alternator belts.

- a. Adjust loose belts (para. 4-2).
- b. Replace missing belts (para. 4-2).

Test 2. Test charging voltage (malfunction 9, test 2).

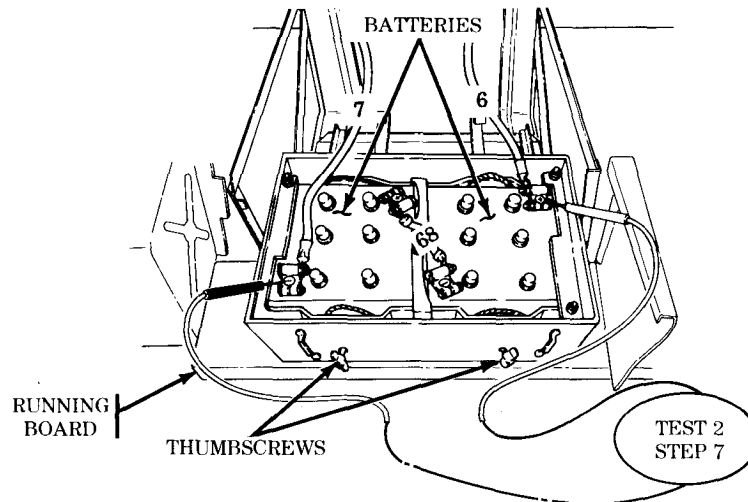

END OF TESTING!

Table 2-4. Electrical Troubleshooting (Contd).

MALFUNCTION	TEST OR INSPECTION	CORRECTIVE ACTION
-------------	--------------------	-------------------

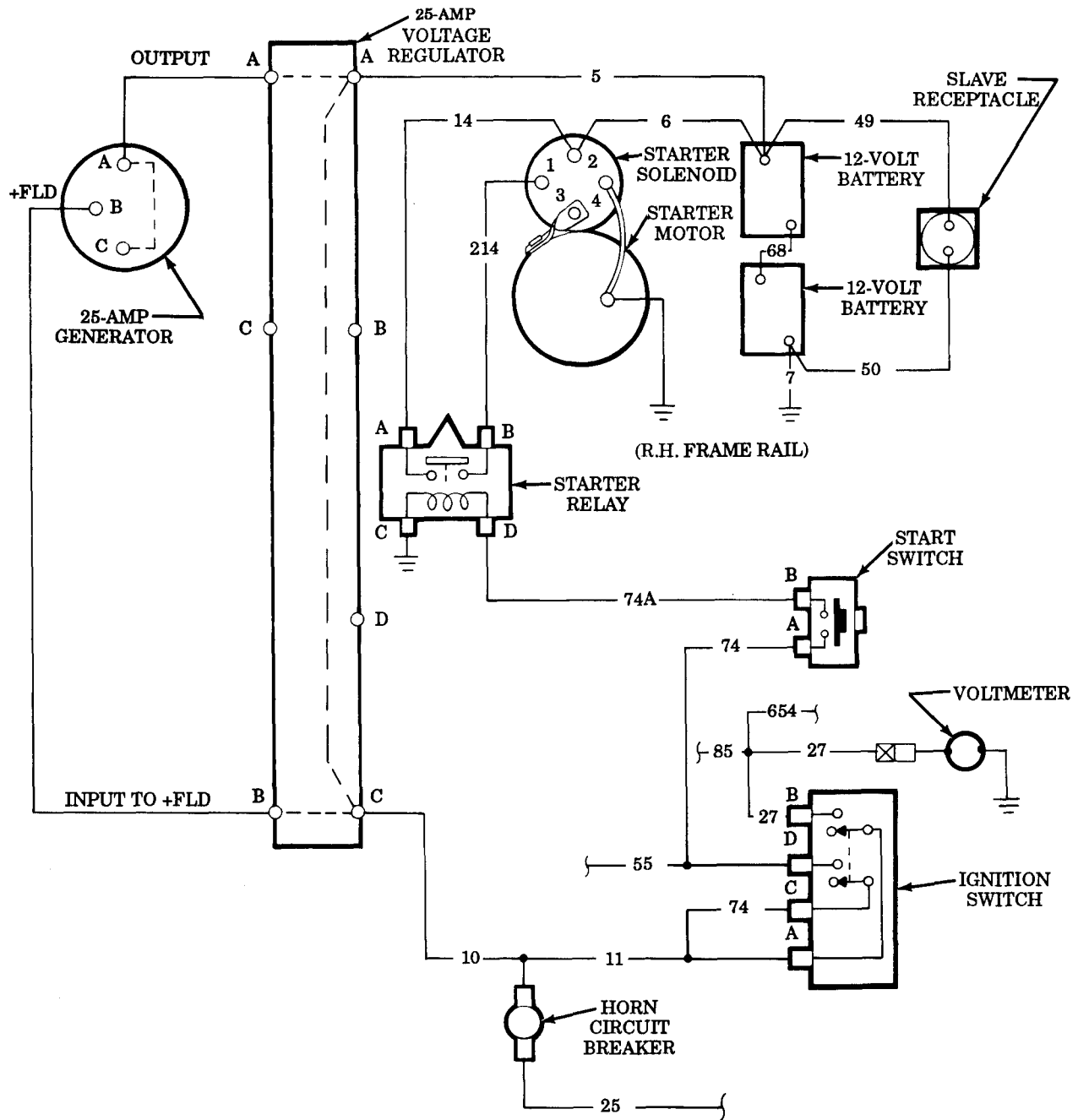

**CHARGING SYSTEM (25 AMP)**

**14. NO GENERATOR OUTPUT (GENERATOR IN LEFT-HAND RED)**

Test 25 amp charging system (malfunction 16, tests 1 and 2).

END OF TESTING!

Table 2-4. Electrical Troubleshooting (Contd).

MALFUNCTION	TEST OR INSPECTION	CORRECTIVE ACTION
-------------	--------------------	-------------------

**15. BATTERIES NOT CHARGING PROPERLY (GENERATOR IN YELLOW OR RIGHT-HAND RED)**

Test 25 amp charging system (malfunction 16, tests 1 and 2).

END OF TESTING!

**16. BATTERIES RUN DOWN IN OPERATION**

**NOTE**

If STE/ICE is available, perform NG50 - charging circuit tests (chapter 2, section VII).

Test 1. Check for loose or missing alternator belts.

- a. Adjust loose belts (para. 4-2).
- b. Replace missing belts (para. 4-2).

Test 2. Test charging voltage across batteries.

- Step 1. Open door of battery compartment. Loosen two thumbscrews and slide batteries onto running board.
- Step 2. Use multimeter to check for battery voltage.
- Step 3. Start engine (TM 9-2320-361-10).
- Step 4. Set engine speed at 1200 rpm.
- Step 5. Turn vehicle headlights and accessories to ON position.
- Step 6. Use multimeter to check battery voltage. Charging voltage on batteries should be  $28.0 \pm 0.2$  Vdc.
  - a. If charging voltage is between 24.0 to 26.0 Vdc, 25 amp charging system is not to be repaired. Replace 25 amp charging system with 60 amp alternator conversion kit 11647745 (para. 4-3).
  - b. If charging voltage is between 26.0 to 30.0 Vdc, remove plug from top or side of regulator. Turn voltage adjusting reostat until charging voltage across battery is  $28.0 \pm 0.2$  Vdc.
  - c. If voltage cannot be adjusted, replace 25 amp charging system with 60 amp conversion kit 11647745 (para. 4-3).
  - d. If charging voltage can be adjusted to  $28.0 \pm 0.2$  Vdc, go to step 7.

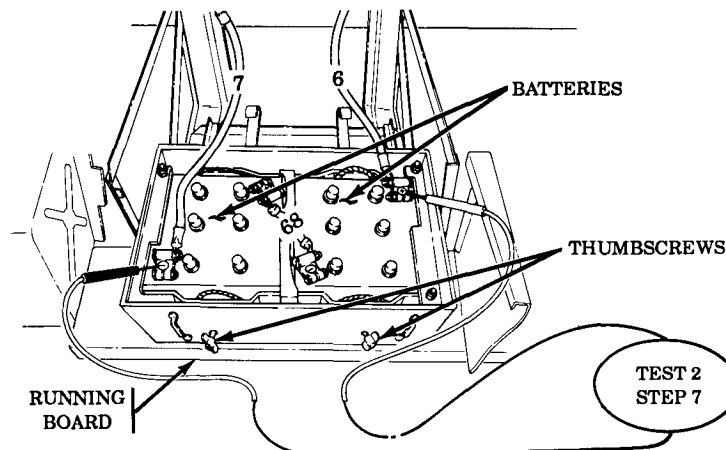



Table 2-4. Electrical Troubleshooting (Contd).

MALFUNCTION	TEST OR INSPECTION	CORRECTIVE ACTION
-------------	--------------------	-------------------

Step 7. Check voltage regulator stability by varying engine speed.

- a. Decrease engine speed to 1000 rpm with headlights on. Regulated battery voltage should remain at  $28.0 \pm 0.2$  Vdc.
- b. If battery voltage drops below 27.5 Vdc, do not repair 25 amp charging system. Replace with 60 amp alternator conversion kit 11647745 (para. 4-3).
- c. Increase engine speed to 2000 rpm with headlights on. Regulated voltage should remain at  $28.0 \pm 0.2$  Vdc.
- d. If battery voltage increases above 28.5 Vdc, replace 25 amp charging system with 60 amp alternator conversion kit 11647745 (para. 4-3).
- e. Return engine speed to 1200 rpm.
- f. Turn headlights OFF and ON and observe change in battery voltage.
- g. If battery voltage changes more than  $\pm 0.5$  Vdc and does not return quickly to  $28.0 \pm 0.2$  Vdc, replace 25 amp charging system with 60 amp alternator conversion kit 11647745 (para. 4-3).

END OF TESTING!

**SERVICE DRIVE AND STOPLIGHT SYSTEM**

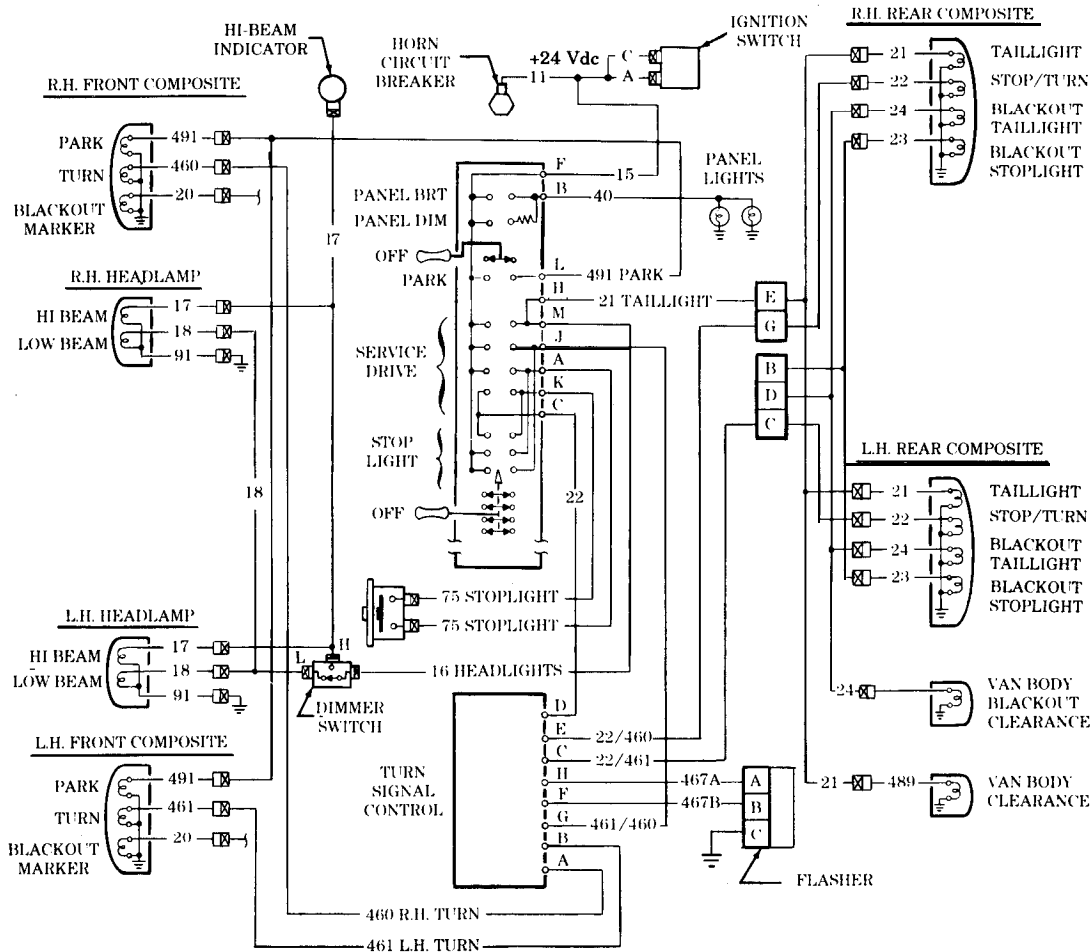

Table 2-4. Electrical Troubleshooting (Contd).

MALFUNCTION	TEST OR INSPECTION	CORRECTIVE ACTION
-------------	--------------------	-------------------

**LIGHTING SYSTEM**

**17. HEADLIGHT DOES NOT OPERATE ON LOW OR HIGH BEAM, OR BOTH HEADLIGHTS INOPERATIVE**

Test 1. Test headlamp connection voltage.

Step 1. Check for loose connections at headlamp and wiring harness and for broken headlamp.

Step 2. Turn main light switch to OFF position.

Step 3. Disconnect leads 17 (high beam), 18 (low beam), and 91 (ground) behind headlamp.

Step 4. Turn main light switch lever to SERVICE DRIVE position.

Step 5. Check low beam and high beam voltage.

- a. Push dimmer switch to LOW position. Check for battery voltage between lead 18 and lead 91.
- b. If voltage is present, go to step 6. If voltage is not present, go to test 2.
- c. Push dimmer switch to HIGH position. Check for battery voltage between lead 17 and lead 91.
- d. If voltage is present, go to step 6.

Step 6. Check continuity of LOW-beam filament.

- a. Place multimeter leads between headlamp connectors 18 and 91 at rear of headlamp.
- b. If continuity is not present, replace sealed beam headlamp (para. 4-39).

Step 7. Check continuity of HIGH-beam filament.

- a. Place multimeter leads between headlamp connectors 17 and 91 at rear of headlamp.
- b. If continuity is not present, replace sealed beam headlamp (para. 4-39).

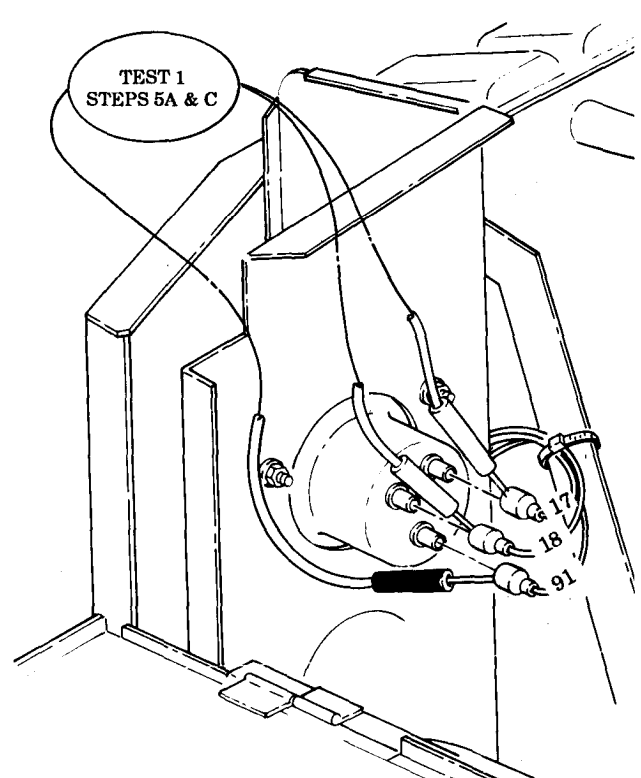
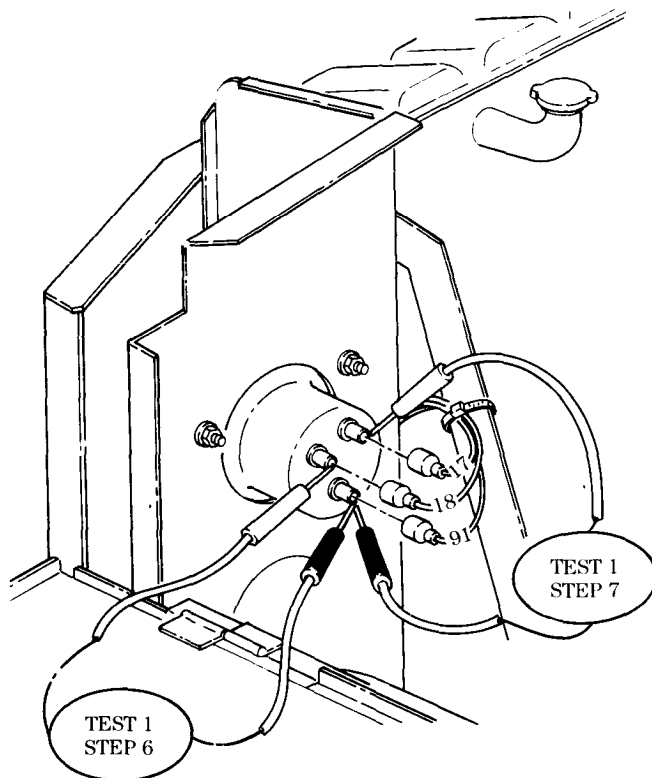

Table 2-4. Electrical Troubleshooting (Contd).

MALFUNCTION	TEST OR INSPECTION	CORRECTIVE ACTION
-------------	--------------------	-------------------

Test 2. Test dimmer switch.

Step 1. Check dimmer switch input voltage.

- a. Remove lead 16 from dimmer switch.
- b. Check lead 16 contact end for battery voltage.
- c. If voltage is present, go to step 2.
- d. If voltage is not present, go to step 3.

Step 2. Check dimmer switch continuity.

- a. Remove lead 17 from dimmer switch pin L. Remove lead 18 from dimmer switch pin H.
- b. Set multimeter to RX1 scale. Check continuity between input pin and pin L.
- c. If continuity is not found, push dimmer switch to change from HIGH to LOW. Recheck continuity.
- d. If no continuity is present, replace dimmer switch (para. 4-28).
- e. If continuity was present, check continuity between pin H and input pin.
- f. If continuity is present, push dimmer switch to ON position to change from LOW to HIGH.
- g. If no continuity is present, replace dimmer switch (para. 4-28).

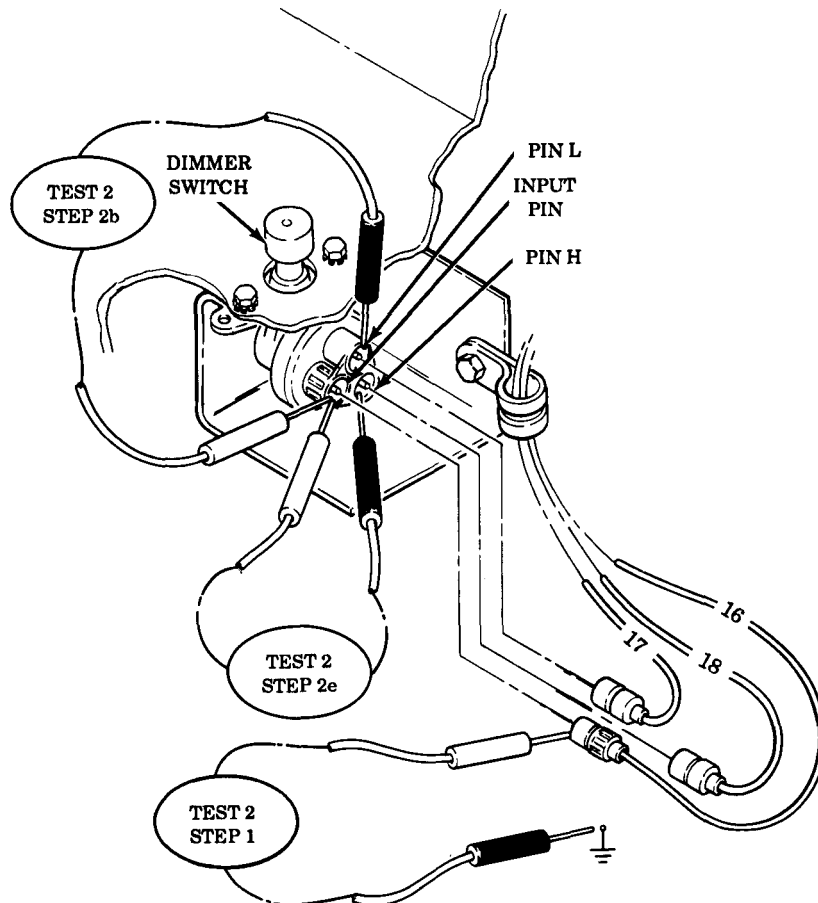

Table 2-4. Electrical Troubleshooting (Contd).

MALFUNCTION	TEST OR INSPECTION	CORRECTIVE ACTION
-------------	--------------------	-------------------

Test 3. Test lighting system harness connector voltage.

- Step 1. Turn main light switch lever to OFF position.
- Step 2. Remove light switch assembly from instrument panel (para. 4-18).
- Step 3. Disconnect harness connector from light switch assembly (para. 4-18).
- Step 4. Check for battery voltage in harness connector at pin F.

**CAUTION**

Voltage at pin F is tied directly to battery without fuse protection. Insert jumper wire in pin of faulty circuit being tested first to prevent energized jumper wire from touching ground and damaging wiring harness.

- a. If battery voltage is indicated at pin F, connect a jumper wire from pin F to socket pin of faulty circuit.
  - b. If lamps light with jumper wire connected, replace main light switch (para. 4-18).
  - c. If battery voltage is not indicated, go to step 5.
- Step 5. Check circuit 15 for loose connections or broken wire.  
Repair broken wire. If wiring cannot be repaired, notify your supervisor.
- Step 6. Reconnect front wiring harness connector to light switch and reinstall light switch (para. 4-18).

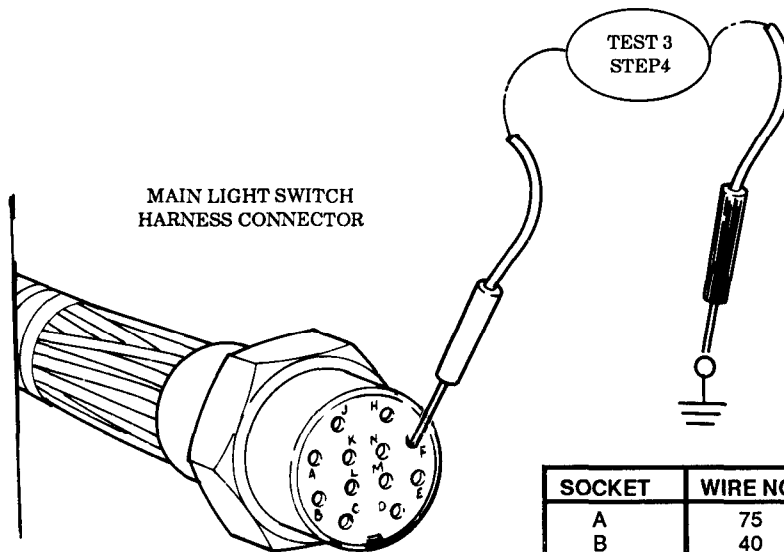

SOCKET	WIRE NO.	CIRCUIT
A	75	STOPLIGHT SWITCH
B	40	PANEL LIGHTS
C	22	DIRECTIONAL CONTROL
D	19	B.O. DRIVING LIGHT
E	20-24	B.O. MARKER LIGHTS
F	15	BATTERY POS. 24 VOLTS
H	21	SERVICE REAR LIGHTS
J	460-461	DIRECTIONAL INDICATOR
K	75	STOPLIGHT SWITCH
L	491	SERVICE PARKING LIGHTS
M	16	SERVICE HEADLIGHTS
N	23	B.O. STOPLIGHT

END OF TESTING!

Table 2-4. Electrical Troubleshooting (Contd).

MALFUNCTION	TEST OR INSPECTION	CORRECTIVE ACTION
-------------	--------------------	-------------------

**18. FRONT MARKER LAMP DOES NOT LIGHT**

Test 1. Test battery voltage at front composite light.

Step 1. Turn auxiliary light switch lever to OFF position.

Step 2. Disconnect lead 491 at rear of front composite light with lamp failure.

Step 3. Turn auxiliary light switch to PARK position.

Step 4. Check for battery voltage on contact end of lead 491.

a. If battery voltage is present, go to test 2.

b. If battery voltage is not present, go to malfunction 17, test 3, and test lighting system harness connector pin L.

Test 2. Test continuity of filament in front marker lamp.

Set multimeter to RX1 scale. Check continuity between frame ground and lead 491 connected to front composite light.

a. If continuity is not present, replace marker lamp (para. 4-45).

b. If continuity is present, check for corroded contacts at lamp and lead 491 connection to front wiring harness. Reconnect lead 491.

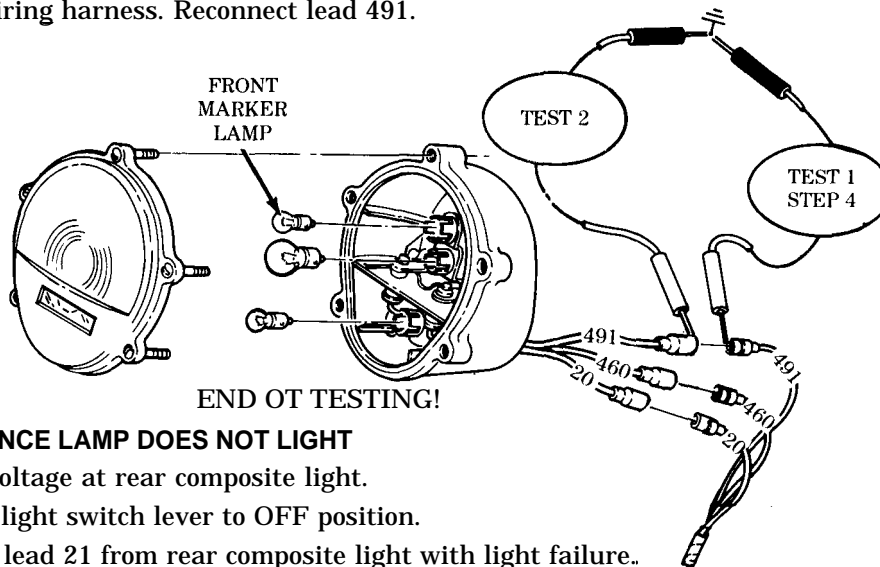

**19. TAILLIGHT OR CLEARANCE LAMP DOES NOT LIGHT**

Test 1. Test battery voltage at rear composite light.

Step 1. Turn main light switch lever to OFF position.

Step 2. Disconnect lead 21 from rear composite light with light failure.

Step 3. Turn main light switch lever to SERVICE DRIVE position.

Step 4. Check for battery voltage on contact end of lead 21.

a. If battery voltage is present, go to test 2 and check lamp filaments (para. 4-46).

b. If voltage is not present, go to malfunction 17, test 3, and check front wiring harness pin H.

Test 2. Test continuity of filament in taillight lamp.

Set multimeter to RX1 scale. Check continuity between lead 21 connected to rear composite light and frame ground.

a. If continuity is not present, replace taillight lamp (para. 4-46).

b. If continuity is present, check for corroded contacts at lamp and lead 21 connection to rear wiring harness. Reconnect lead 21.

END OF TESTING!

Table 2-4. Electrical Troubleshooting (Contd).

MALFUNCTION	TEST OR INSPECTION	CORRECTIVE ACTION
-------------	--------------------	-------------------

**20. STOPLIGHT LAMP DOES NOT LIGHT**

Test 1. Test battery voltage at rear composite light.

Step 1. Turn main light switch to OFF position.

Step 2. Disconnect lead 22/460 or lead 22/461 from rear composite light on side of vehicle where stoplight has failed.

**NOTE**

Ensure turn indicator is in NEUTRAL position.

Step 3. Check for battery voltage on contact end of lead 22/460 or 22/461.

a. Depress brake pedal to activate stoplight switch.

b. If voltage is present, go to test 2 and check lamp filament.

c. If battery voltage is not present, go to malfunction 17, test 3, and test lighting system harness connector pin C.

Test 2. Test continuity of filament in stoplight lamp.

Check continuity between frame grounds and lead 22/460 or 22/461 connected to rear composite light.

If continuity is present, check for corroded contacts at lamp and leads 22/460 or 22/461 connection to rear wiring harness. Reconnect lead 22/461 or 22/460.

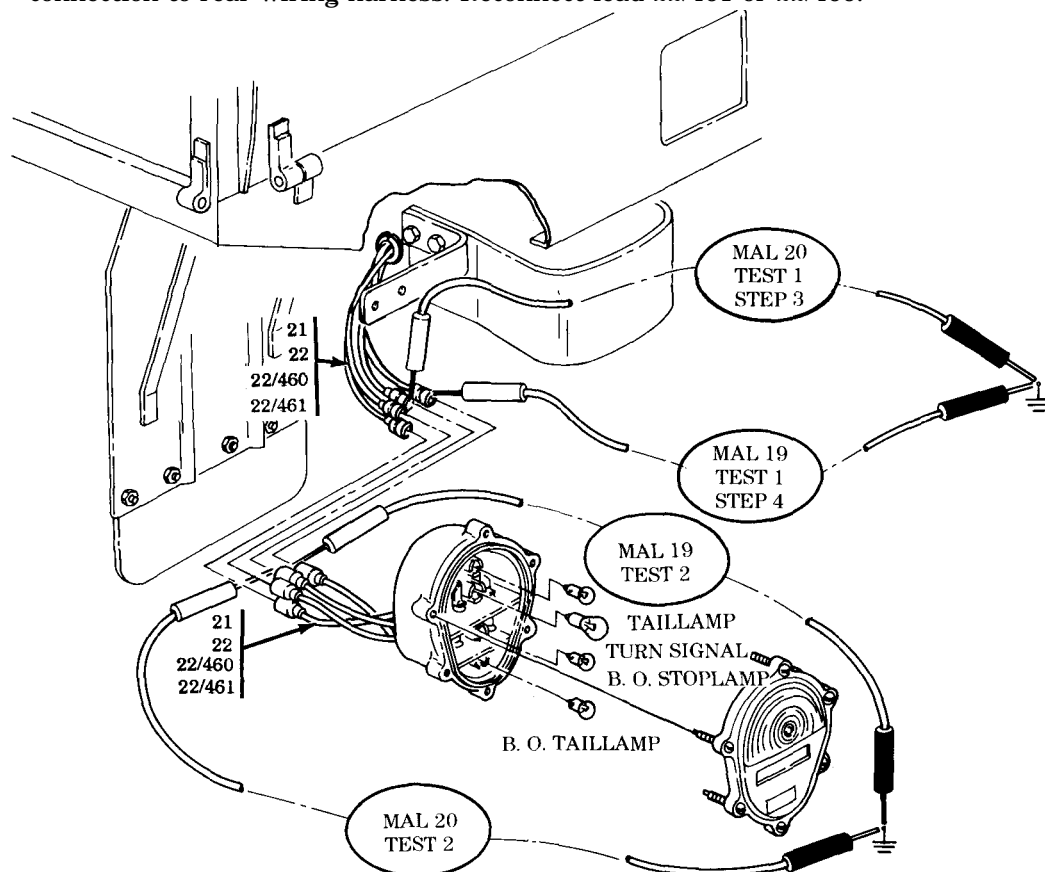

END OF TESTING!

Table 2-4. Electrical Troubleshooting (Contd).

MALFUNCTION	TEST OR INSPECTION	CORRECTIVE ACTION
-------------	--------------------	-------------------

**BLACKOUT LIGHTS**

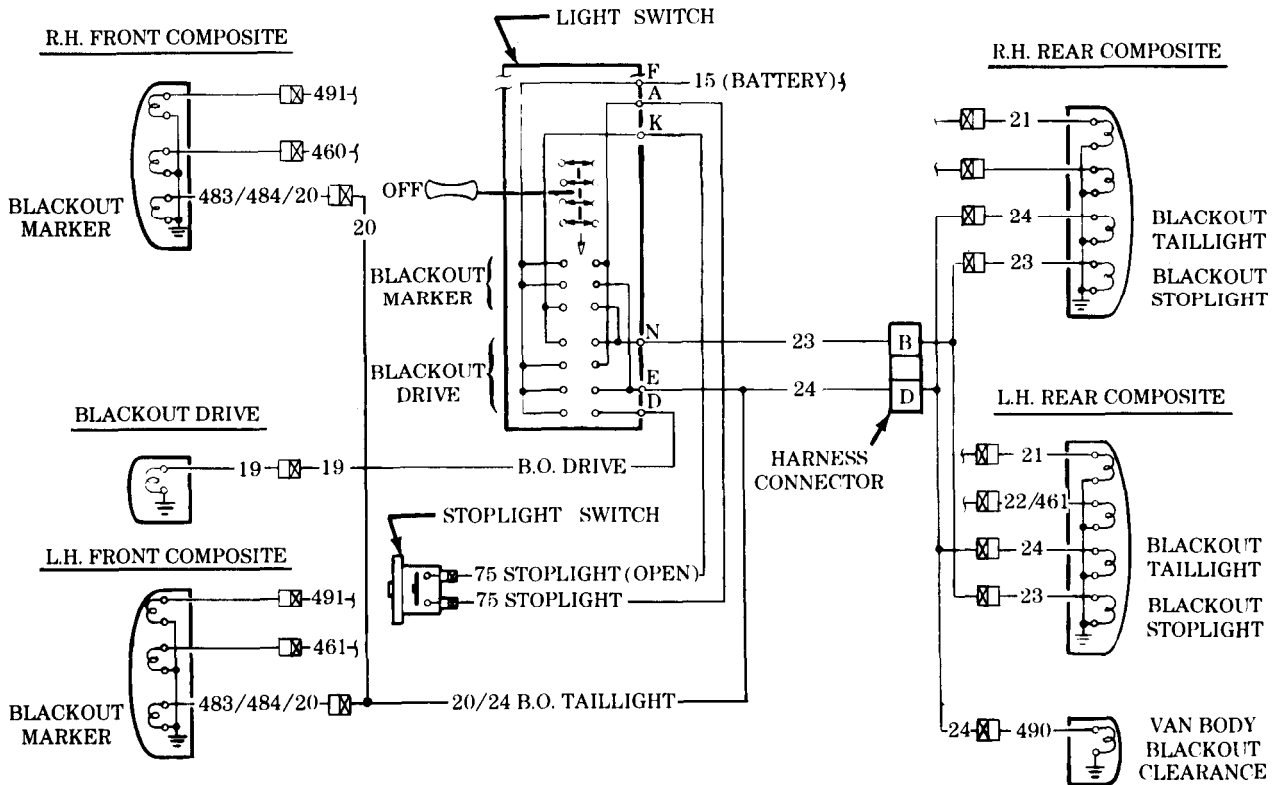

**21. BLACKOUT HEADLAMP DOES NOT LIGHT**

Test 1. Test battery voltage at blackout drive light.

Step 1. Turn main light switch lever to OFF position.

Step 2. Disconnect lead 19 from blackout drive light.

Step 3. Turn main light switch to BLACKOUT DRIVE position.

Step 4. Check for battery voltage on contact end of lead 19.

- a. If battery voltage is present, go to test 2.
- b. If battery voltage is not present, go to malfunction 17, test 3, and check front wiring harness pin D.

Test 2. Test continuity of filament in blackout drive light.

Set multimeter to RX1 scale. Check continuity between frame ground and lead 19 attached to rear of blackout drive light.

- a. If continuity is not present, replace blackout drive lamp (para. 4-42).
- b. If continuity is present, check for corroded contacts at lamp and at lead 19 connection to front wiring harness. Reconnect lead 19.

END OF TESTING!

Table 2-4. Electrical Troubleshooting (Contd).

MALFUNCTION	TEST OR INSPECTION	CORRECTIVE ACTION
-------------	--------------------	-------------------

**22. FRONT BLACKOUT MARKER LAMP DOES NOT LIGHT**

Test 1. Test battery voltage at front marker light.

- Step 1. Turn main light switch to OFF position.
- Step 2. Disconnect lead 20 at rear of front composite light on side of vehicle where light does not light.
- Step 3. Turn main light switch lever to BLACKOUT MARKER or BLACKOUT DRIVE position.
- Step 4. Check for battery voltage at contact end of lead 20.
  - a. If battery voltage is present, go to test 2.
  - b. If battery voltage is not present, go to malfunction 17, test 3, and check front wiring harness pin E.

Test 2. Test continuity of filament in blackout marker lamp.

- Step 1. Set multimeter to RX1 scale. Check continuity between frame ground and lead 20 attached to rear of blackout marker lamp.
- Step 2. If continuity is not present:
  - a. Replace blackout marker lamp (para. 4-46).
  - b. If continuity is present, check for corroded contacts at lamp and at lead 20 connection to front wiring harness. Reconnect lead 20.

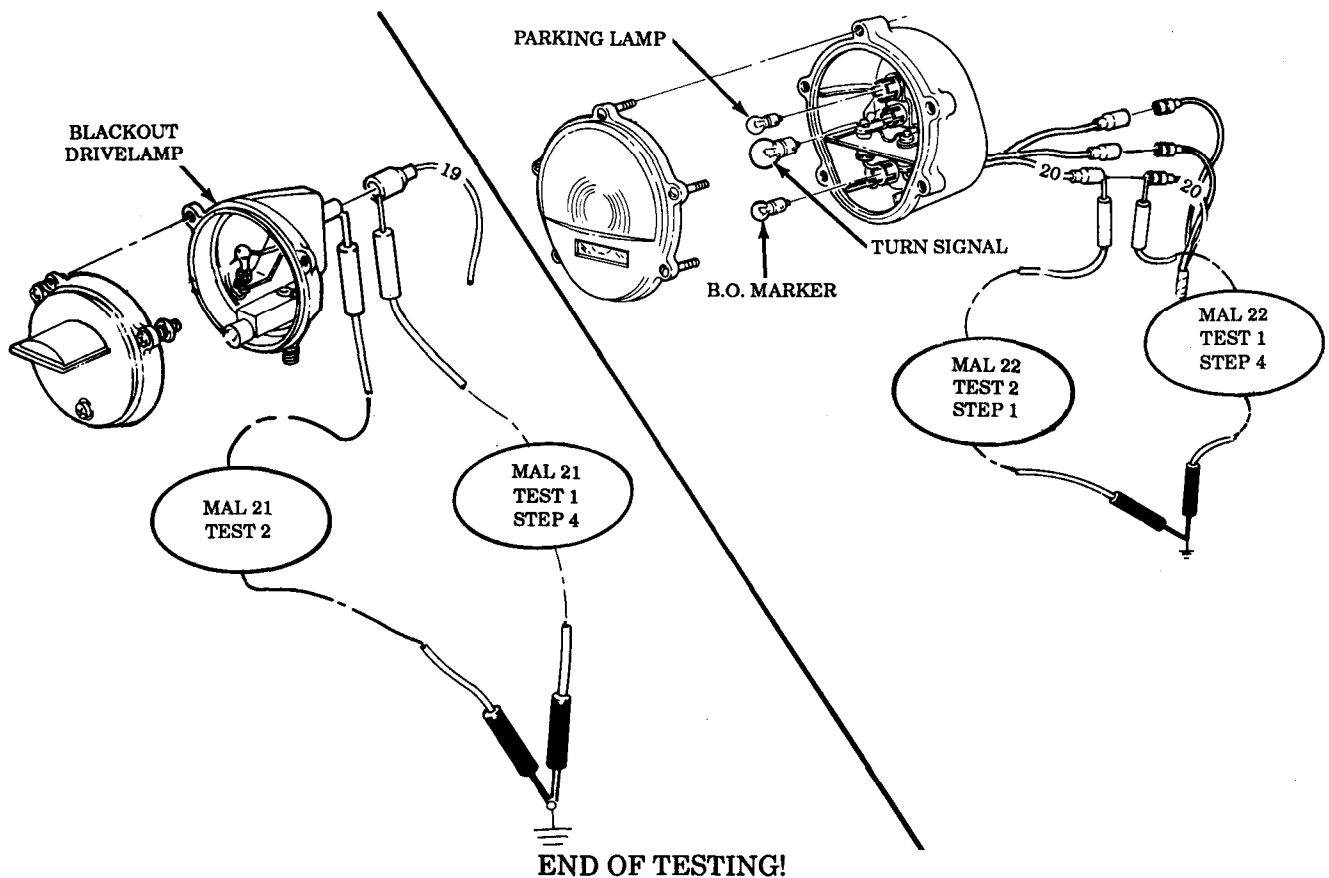



Table 2-4. Electrical Troubleshooting (Contd).

MALFUNCTION	TEST OR INSPECTION	CORRECTIVE ACTION
-------------	--------------------	-------------------

**23. BLACKOUT TAILLIGHT LAMP DOES NOT LIGHT**

Test 1. Test battery voltage at rear composite light.

Step 1. Turn main light switch to OFF position.

Step 2. Disconnect lead 24 at rear composite light on side of vehicle where blackout taillight has failed.

Step 3. Turn main light switch to BLACKOUT MARKER or BLACKOUT DRIVE positions.

Step 4. Check for battery voltage at contact end of lead 24.

a. If battery voltage is present, go to test 2.

b. If battery voltage is not present, go to malfunction 17, test 3, and check front wiring harness pin E.

Test 2. Test continuity of filament in blackout taillight lamp.

Check continuity between lead 24 attached to rear composite light and frame ground.

a. If continuity is not present, replace blackout taillight lamp (para. 4-46).

b. If continuity is present, check for corroded contacts at lamp and on lead 24 connection to rear wiring harness. Reconnect lead 24.

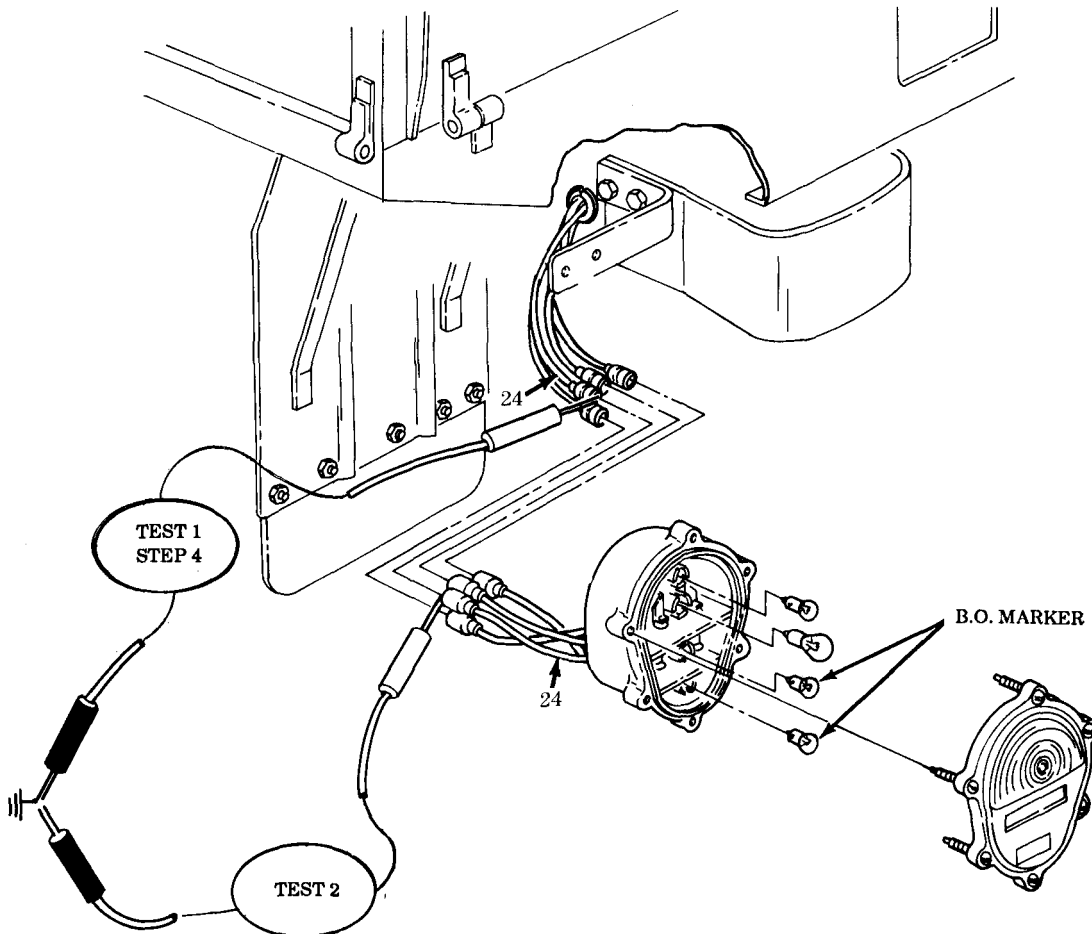

END OF TESTING!

Table 2-4. Electrical Troubleshooting (Contd).

MALFUNCTION	TEST OR INSPECTION	CORRECTIVE ACTION
-------------	--------------------	-------------------

**24. BLACKOUT STOPLIGHT LAMP DOES NOT LIGHT**

Test 1. Test for battery voltage at rear composite light.

- Step 1. Turn main light switch to OFF position.
- Step 2. Disconnect lead 23 at rear composite light on side of vehicle where blackout stoplight has failed.
- Step 3. Turn main light switch to BLACKOUT MARKER or BLACKOUT DRIVE positions.
- Step 4. Depress brake pedal and check for battery voltage on contact end of lead 23.
  - a. If battery voltage is present, go to test 2.
  - b. If battery voltage is not present, go to malfunction 17, test 3, and check front wiring harness, pin N.

Test 2. Test continuity of filament in blackout stoplight lamp.

Check continuity between lead 23 attached to rear composite light and frame ground.

- a. If continuity is not present, replace blackout taillight lamp (para. 4-46).
- b. If continuity is present, check for corroded contacts at lamp and on lead 23 connection to rear wiring harness. Reconnect lead 23.

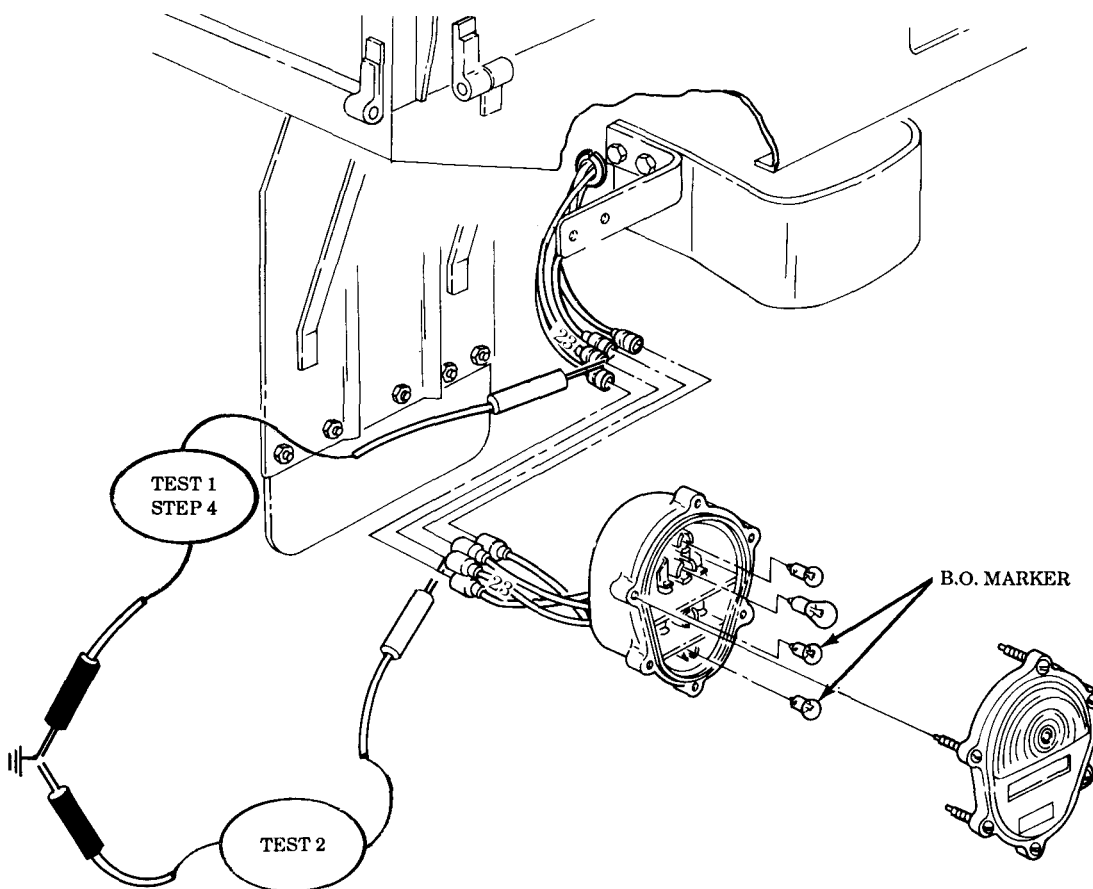

END OF TESTING!

Table 2-4. Electrical Troubleshooting (Contd).

MALFUNCTION	TEST OR INSPECTION	CORRECTIVE ACTION
-------------	--------------------	-------------------

**DIRECTIONAL SIGNAL SYSTEM**

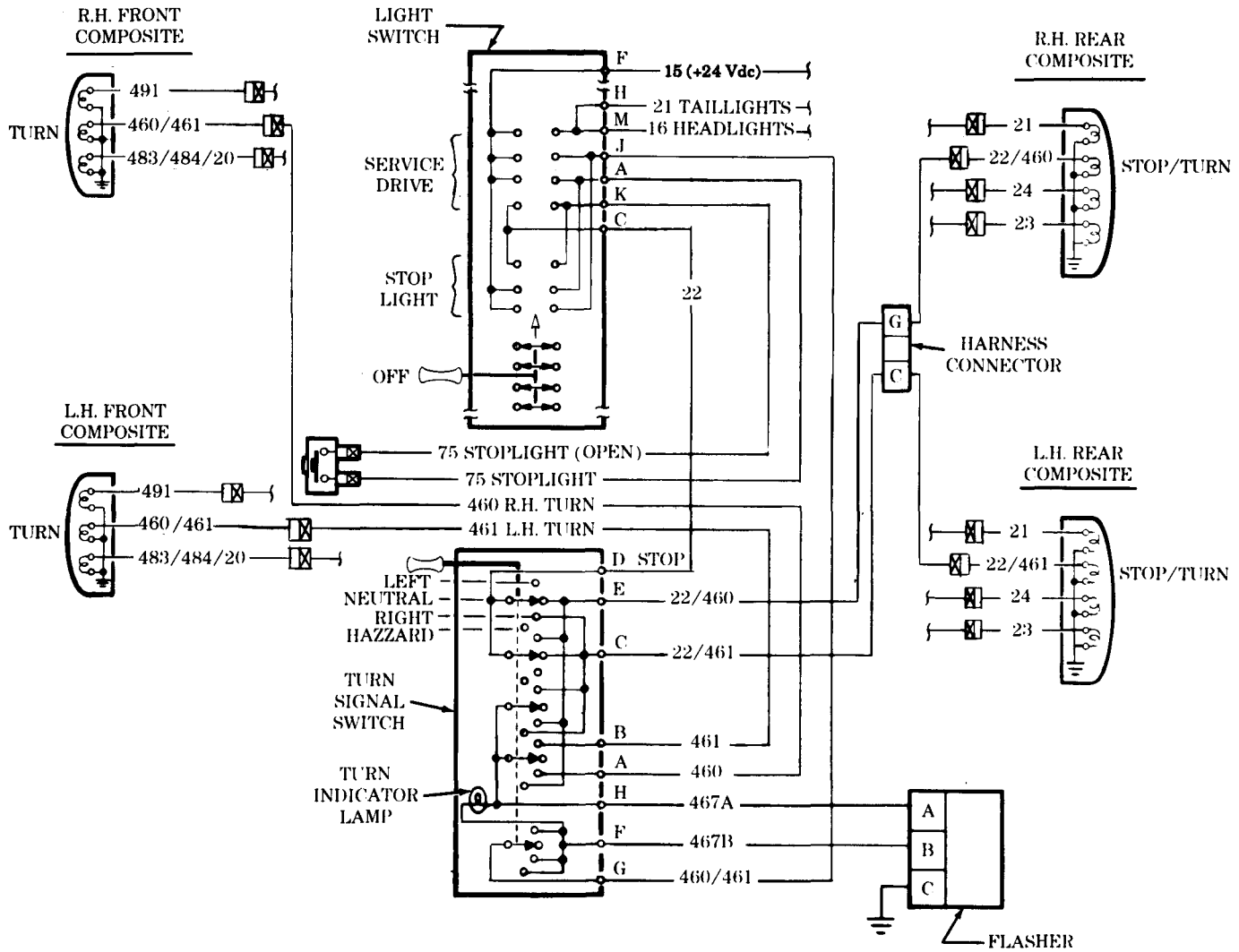

**25. DIRECTION SIGNAL INOPERATIVE**

Test 1. Test turn signal lamps.

Step 1. Turn main light switch to SERVICE DRIVE.

Step 2. Place turn signal in left or right position, turn signal should flash on both sides.

- a. If turn signal on left or right operates, go to test 2.
- b. If turn signal on left or right operates, but does not flash, go to test 3.

Table 2-4. Electrical Troubleshooting (Contd).

MALFUNCTION	TEST OR INSPECTION	CORRECTIVE ACTION
-------------	--------------------	-------------------

**NOTE**

Testing procedures for left and right turn signal leads 461 and 460 are performed the same using tests 1 through 8. This test covers left side 461 turn signal circuit.

Test 2. Test for voltage at front composite lights.

Step 1. Disconnect lead 461 at left front composite light.

Step 2. Place turn signal lever to LEFT position.

Step 3. Set multimeter to a range that will measure 24 volts.

Step 4. Touch multimeter negative lead to frame ground.

Step 5. Touch multimeter positive lead to contact end of lead 461 (left). Voltage should fluctuate at a rate of 1 or 2 cycles per second.

a. If voltage does fluctuate, go to test 3.

b. If voltage does not fluctuate, go to test 4.

Test 3. Test continuity of filament and socket for turn signal lamp. Check continuity between lead 460/461 attached to front composite light and frame ground.

a. If continuity is present, reconnect leads 460/461 and check turn signal operation. If turn signal operates but does not flash, go to tests 6 and 7.

b. If continuity is not present, replace turn signal lamp (para. 4-19).

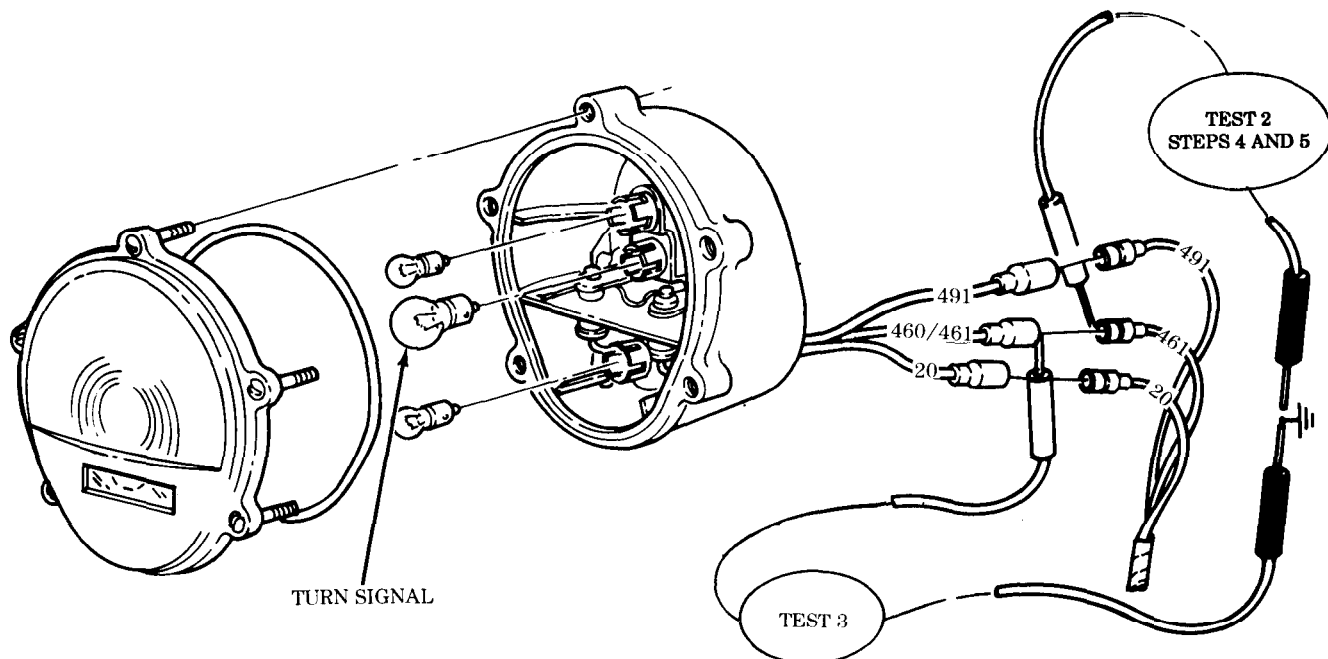

Table 2-4. Electrical Troubleshooting (Contd).

MALFUNCTION	TEST OR INSPECTION	CORRECTIVE ACTION
-------------	--------------------	-------------------

- Test 4. Test continuity of front composite light wiring harness.
- Step 1. Disconnect lead 461 from front composite light.
  - Step 2. Disconnect cable connector at turn signal switch.
  - Step 3. Set multimeter to RX1 scale.
  - Step 4. Touch multimeter negative lead to pin B at cable connector.
  - Step 5. Touch multimeter positive lead to contact end of lead 461 at front composite light.
    - a. Continuity should be present.
    - b. If continuity is not present, replace or repair lead 461 (para 4-51).
    - c. Perform test 4 again. If lamp fails to flash, go to test 5.
- Test 5. Test continuity of turn signal switch.
- Step 1. Disconnect cable connector at turn signal switch.
  - Step 2. Place turn signal switch to LEFT position.
  - Step 3. Touch multimeter negative lead to pin G of turn signal switch.
  - Step 4. Touch multimeter positive lead to pin B 461 (front left) and pin C 22/461 (left rear) of turn signal switch.
    - a. Continuity should be present.
    - b. If continuity is not present, replace turn signal switch (para. 4-19).
  - Step 5. Place turn signal lever to RIGHT position.
  - Step 6. Touch multimeter positive lead to pin A 460 (right front) and pin E 22/460 (right rear) at turn signal switch.
    - a. Continuity should be present.
    - b. If continuity is not present, replace turn signal switch (para. 4-19).
  - Step 7. Touch multimeter positive lead to pin F at turn signal switch.
    - a. Continuity should be present.
    - b. If continuity is not present, replace turn signal switch (para. 4-19).

Table 2-4. Electrical Troubleshooting (Contd).

MALFUNCTION	TEST OR INSPECTION	CORRECTIVE ACTION
-------------	--------------------	-------------------

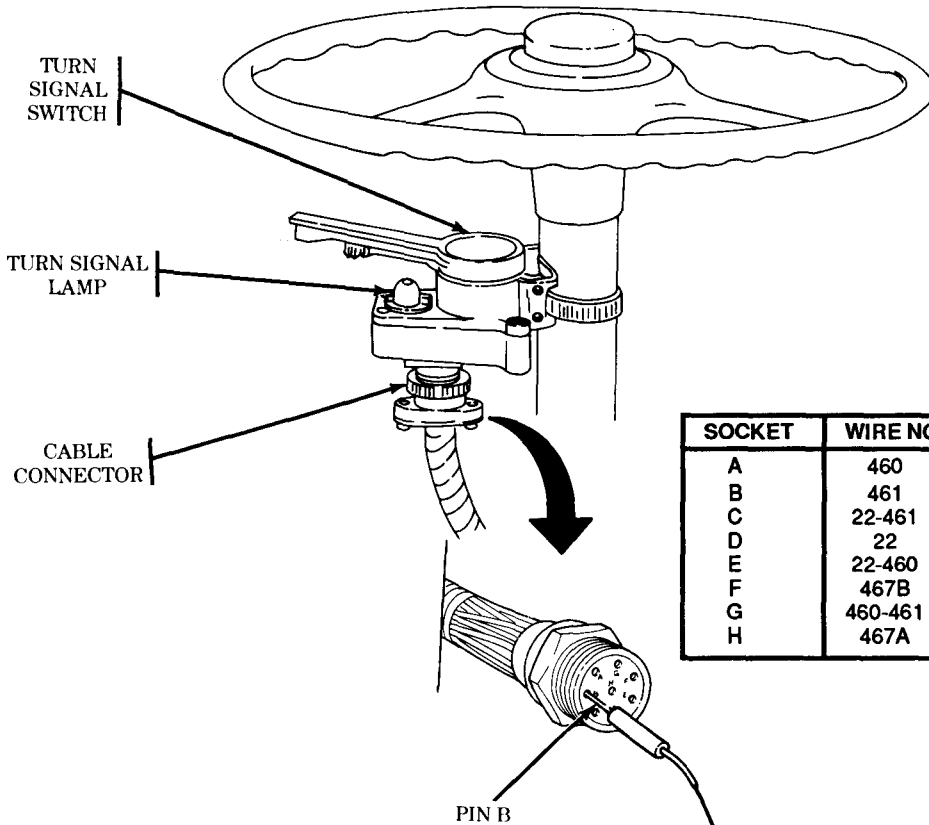

SOCKET	WIRE NO.	CIRCUIT
A	460	R.H. FRONT TURN SIGNALS
B	461	L.H. FRONT TURN SIGNALS
C	22-461	L.H. REAR TURN SIGNALS
D	22	STOPLIGHT INPUT
E	22-460	R.H. REAR TURN SIGNALS
F	467B	EMERGENCY FLASHER
G	460-461	FRONT TURN INPUT
H	467A	EMERGENCY FLASHER OUTPUT

TEST 4  
STEPS 4 AND 5

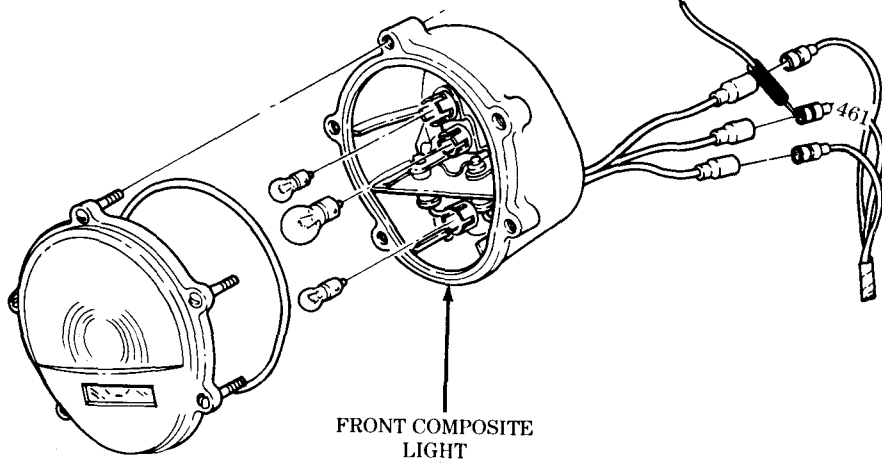

Table 2-4. Electrical Troubleshooting (Contd).

MALFUNCTION	TEST OR INSPECTION	CORRECTIVE ACTION
-------------	--------------------	-------------------

Test 6. Test for voltage at rear composite light.

- Step 1. Disconnect lead 22/461 at left-rear composite light.
- Step 2. Turn main light switch to SERVICE DRIVE position.
- Step 3. Place turn signal switch to LEFT position.
- Step 4. Set multimeter to a voltage range that will measure 24 Vdc.
- Step 5. Touch multimeter negative lead to frame ground.
- Step 6. Touch multimeter positive lead to contact end of lead 22/461. Voltage should fluctuate at a rate of 1 or 2 cycles per second.
  - a. If voltage does fluctuate, go to test 7.
  - b. If voltage does not fluctuate, go to test 8.

Test 7. Test continuity of filament and socket for turn signal lamp.

Check continuity between lead 22/460/461 attached to rear composite light and frame ground.

- a. If continuity is present, reconnect leads 22/460/461 and check turn signal operation.
- b. If continuity is not present, replace turn signal lamp (para. 4-19).

Test 8. Test continuity of lead 22/461 from turn signal switch to rear harness connector.

- Step 1. Set multimeter to RX1 scale.
- Step 2. Disconnect cable connector at turn signal switch.
- Step 3. Disconnect lead 22/461 from rear composite light.
- Step 4. Touch multimeter negative lead to contact end of 22/461.
- Step 5. Touch multimeter positive lead to contact end of lead 22/461 at turn signal cable connector (pin C).
  - a. Continuity should be present.
  - b. If continuity is not present, replace or repair lead 22/461 (para. 4-51).

Table 2-4. Electrical Troubleshooting (Contd).

MALFUNCTION	TEST OR INSPECTION	CORRECTIVE ACTION
-------------	--------------------	-------------------

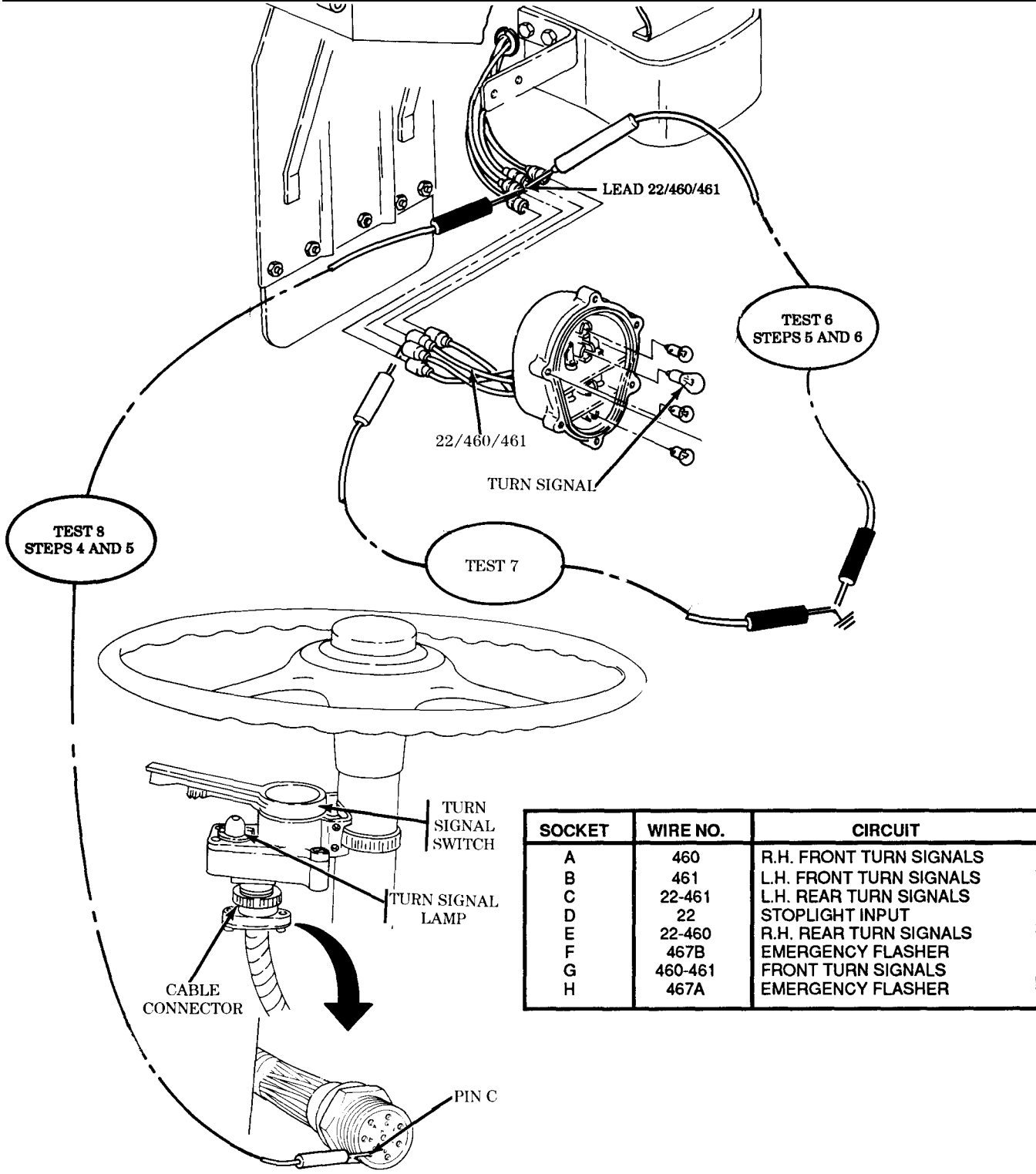

SOCKET	WIRE NO.	CIRCUIT
A	460	R.H. FRONT TURN SIGNALS
B	461	L.H. FRONT TURN SIGNALS
C	22-461	L.H. REAR TURN SIGNALS
D	22	STOPLIGHT INPUT
E	22-460	R.H. REAR TURN SIGNALS
F	467B	EMERGENCY FLASHER
G	460-461	FRONT TURN SIGNALS
H	467A	EMERGENCY FLASHER

END OF TESTING!



Table 2-4. Electrical Troubleshooting (Contd).

MALFUNCTION	TEST OR INSPECTION	CORRECTIVE ACTION
-------------	--------------------	-------------------

**26. ALL STOPLIGHTS ARE INOPERATIVE**

Test 1. Check stoplight switch for input voltage.

Step 1. Turn main light switch to SERVICE DRIVE position.

Step 2. Set multimeter to a voltage range that will measure 24 Vdc.

Step 3. Disconnect lead 75 input voltage from stoplight switch.

Step 4. Touch positive lead of multimeter to contact end of lead 75.

Step 5. Touch negative lead of multimeter to frame ground.

a. Voltage should be present. If voltage is present, go to test 2.

b. If voltage is not present, go to malfunction 17, test 3, depress brake pedal, and check pin A.

Test 2. Check stoplight switch for output voltage.

Step 1. Set multimeter to a voltage range that will measure 24 Vdc.

Step 2. Disconnect output lead 75 from stoplight switch.

Step 3. Touch positive lead of multimeter to contact end of stoplight switch.

Step 4. Touch negative lead of multimeter to frame ground.

Step 5. Depress brake pedal.

**NOTE**

If vehicle is equipped with hydraulic stoplight switch and switch is defective, replace with air-activated stoplight switch conversion kit, part number 12255668.

If voltage is not present, replace stoplight switch (para. 4-29).

Table 2-4. Electrical Troubleshooting (Contd).

MALFUNCTION	TEST OR INSPECTION	CORRECTIVE ACTION
-------------	--------------------	-------------------

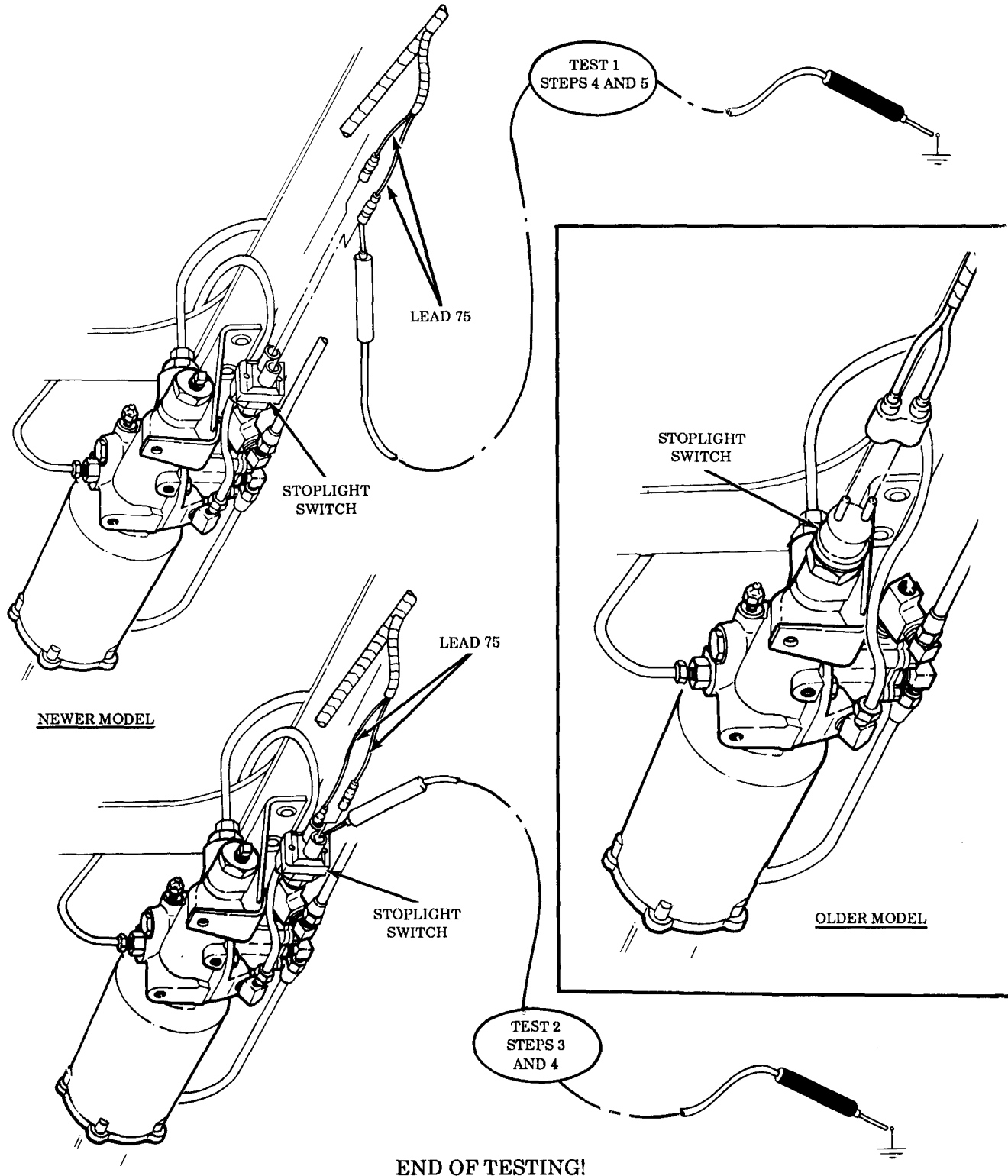

Table 2-4. Electrical Troubleshooting (Contd).

MALFUNCTION	TEST OR INSPECTION	CORRECTIVE ACTION
-------------	--------------------	-------------------

**27. BOTH DIRECTION SIGNALS INOPERATIVE**

Test 1. Test left and right flashers.

Step 1. Turn main light switch to SERVICE DRIVE position.

Step 2. Position turn signal lever to LEFT position.

Step 3. Position turn signal lever to RIGHT position.

a. Both left and right turn signals should flash.

b. If turn signals fail to flash, go to test 2.

Test 2. Test solid state flasher.

Step 1. Disconnect leads 467A and 467B from solid state flasher pins A and B.

Step 2. Connect jumper wire from leads 467A to 467B.

Step 3. Place turn signal lever to LEFT position.

Step 4. Place turn signal lever to RIGHT position.

a. Left and right turn signals should work but will not flash. If turn signals work, replace turn signal flasher (para. 4-20).

b. If voltage is not present, go to malfunction 25 and perform tests 1 through 8.

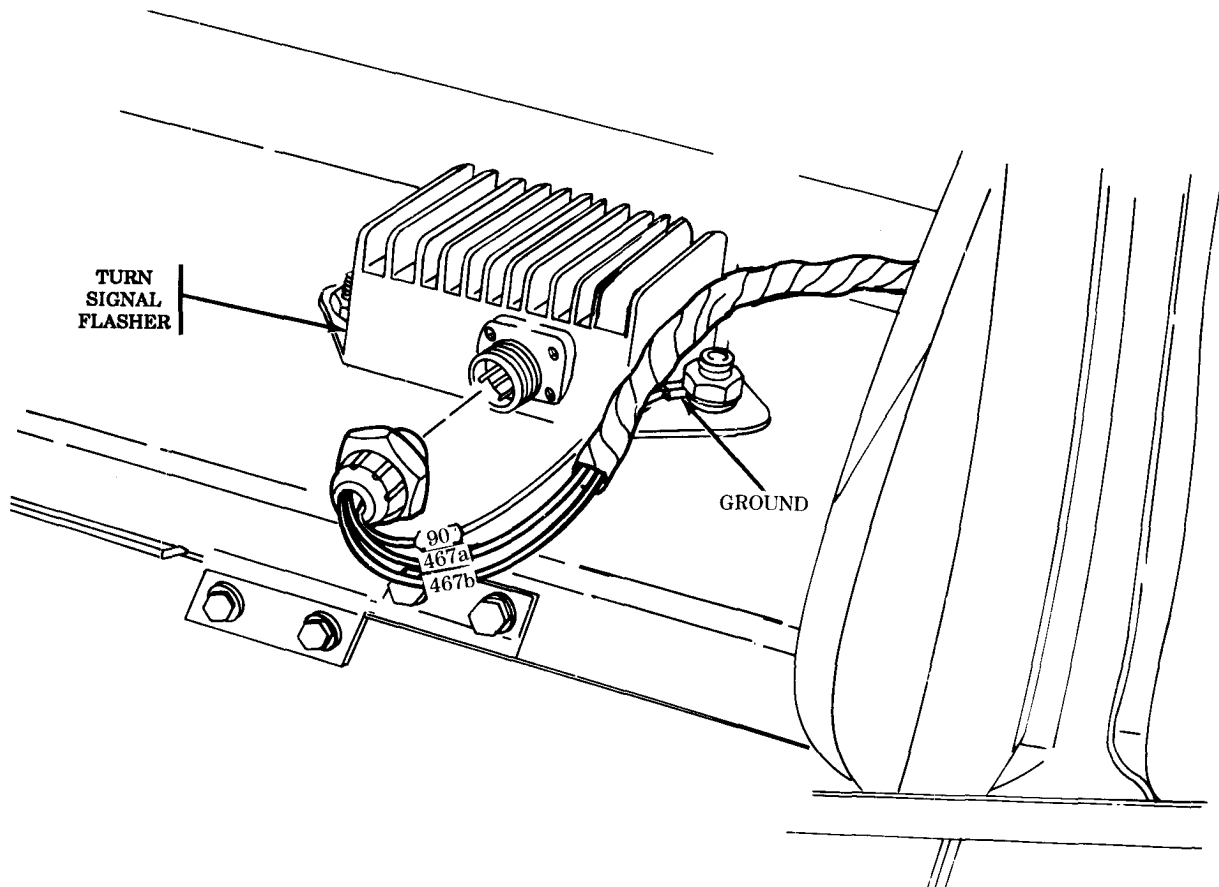

END OF TESTING!

Table 2-4. Electrical Troubleshooting (Contd).

MALFUNCTION	TEST OR INSPECTION	CORRECTIVE ACTION
-------------	--------------------	-------------------

**28. TURN SIGNALS OPERATE INCORRECTLY WITH TURN SIGNAL CONTROL LEVER IN ONE OR MORE POSITIONS**

Test turn signal control unit continuity.

Step 1. Place battery switch to OFF position.

Step 2. Remove harness connector from turn signal switch.

Step 3. Remove indicator lamp from turn signal switch (para. 4-19).

Step 4. Set multimeter to RX1 scale.

Step 5. If any circuit does not test as shown in chart 1 below, replace turn signal switch (para. 4-19).

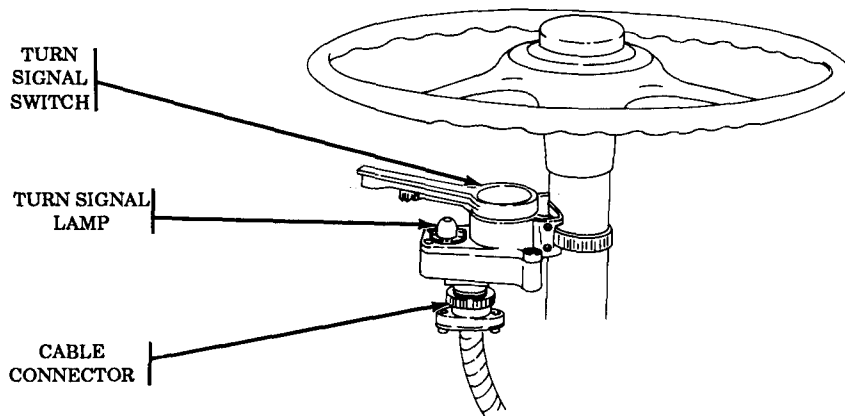

**CONTROL UNIT TEST CHART**

A. DIRECTIONAL SIGNAL CONTROL LEVER IN "NEUTRAL" POSITION			C. DIRECTIONAL SIGNAL CONTROL LEVER IN "RIGHT TURN" POSITION		
FROM PIN	TO PIN	CONTINUITY INDICATION	FROM PIN	TO PIN	CONTINUITY INDICATION
H	A	OPEN	F	G	SHORTED
H	B	OPEN	H	A	SHORTED
H	C	OPEN	H	E	SHORTED
H	E	OPEN	H	B	OPEN
D	C	SHORTED	H	C	OPEN
D	E	SHORTED	D	C	SHORTED
F	G	OPEN	D	E	OPEN
B. DIRECTIONAL SIGNAL CONTROL LEVER IN "LEFT TURN" POSITION			D. DIRECTIONAL SIGNAL CONTROL LEVER IN "HAZARD WARNING" POSITION		
FROM PIN	TO PIN	CONTINUITY INDICATION	FROM PIN	TO PIN	CONTINUITY INDICATION
H	B	SHORTED	H	A	SHORTED
H	C	SHORTED	H	B	SHORTED
H	A	OPEN	H	C	SHORTED
H	E	OPEN	H	E	SHORTED
F	G	SHORTED	D	E	OPEN
D	E	SHORTED	D	C	OPEN
D	C	OPEN	F	G	SHORTED

END OF TESTING!

Table 2-4. Electrical Troubleshooting (Contd).

MALFUNCTION	TEST OR INSPECTION	CORRECTIVE ACTION
-------------	--------------------	-------------------

**INDICATORS, GAGES, AND WARNING SYSTEM**

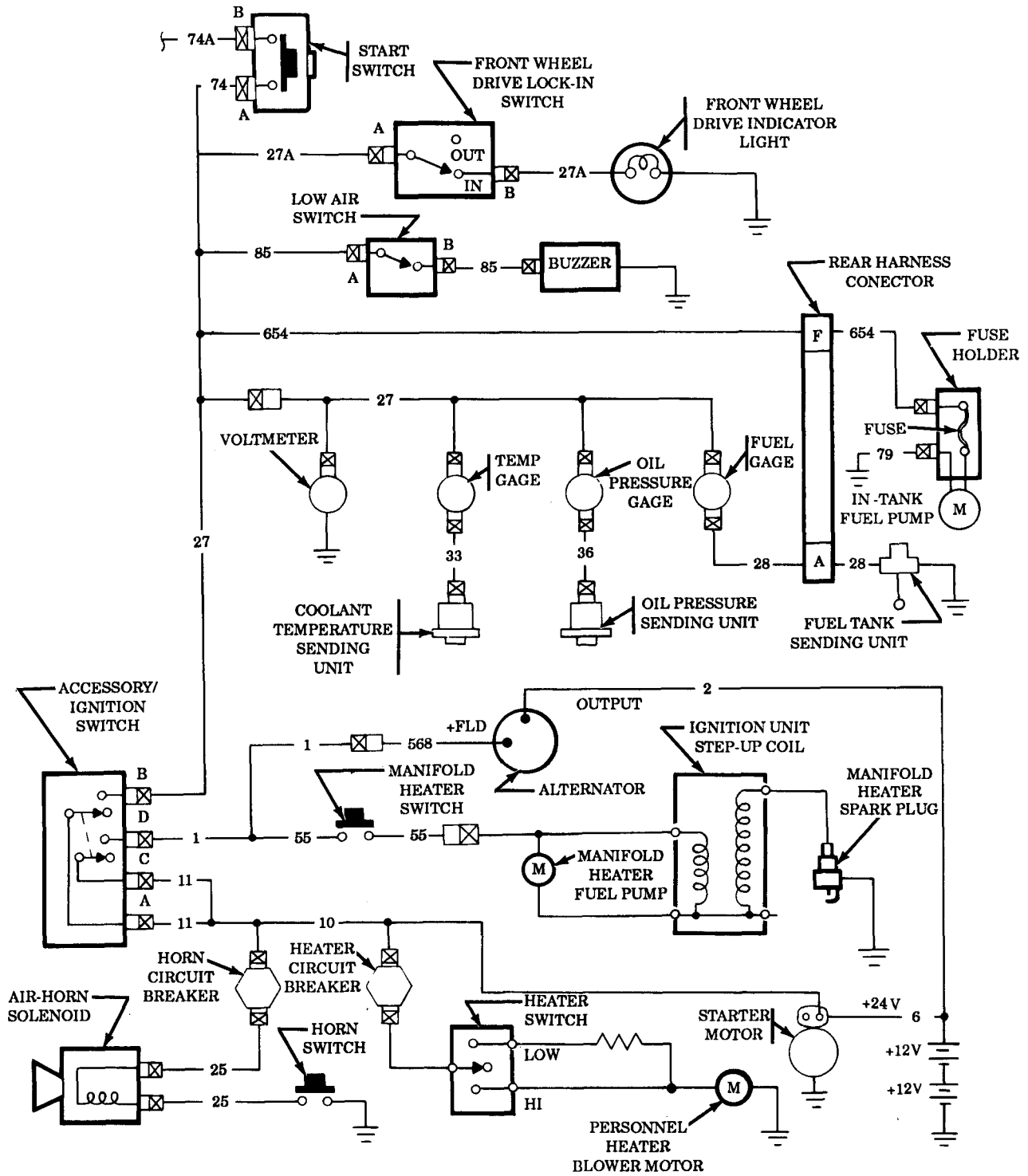

Table 2-4. Electrical Troubleshooting (Contd).

MALFUNCTION	TEST OR INSPECTION	CORRECTIVE ACTION
-------------	--------------------	-------------------

## INDICATORS, GAGES, AND WARNING SYSTEM

### 29. ALL GAGES INOPERATIVE

#### NOTE

If STE/ICE is available, perform NG31 - gage test (chapter 2, section VII).

Test 1. Test starter for proper operation.

Step 1. Turn accessory/ignition switch to ON position.

Step 2. Push start button.

a. If starter cranks engine, go to test 2.

b. If starter does not crank engine, go to malfunction 2 and troubleshoot starter circuit.

Test 2. If problem is still present, test instrument cluster voltage.

Step 1. Turn accessory/ignition switch to OFF position.

Step 2. Remove instrument cluster panel (para. 4-10).

Step 3. Connect battery ground cable (para. 4-48).

Step 4. Connect jumper wire from instrument panel to a good frame ground.

Step 5. Disconnect lead 27 from the temperature gage.

Step 6. Use multimeter or 24-volt test lamp to check voltage on contact end of lead 27 at gage.

a. Place positive lead on contact end of lead 27.

b. Place negative lead on frame ground.

c. If battery voltage is present, go to malfunction 30 for temperature gage.

Step 7. Set multimeter to RX1.

Step 8. Check continuity of lead 27.

a. Disconnect lead 27 from front wiring harness.

b. If continuity is not present, replace or repair lead 27 (para. 4-51).

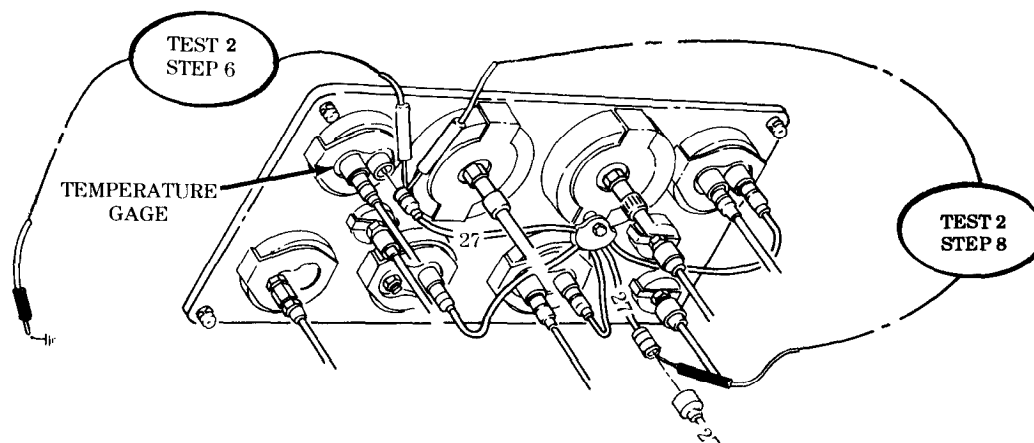

END OF TESTING!

Table 2-4. Electrical Troubleshooting (Contd).

MALFUNCTION	TEST OR INSPECTION	CORRECTIVE ACTION
-------------	--------------------	-------------------

**30. ENGINE TEMPERATURE GAGE INOPERATIVE**

**NOTE**

If STE/ICE is available, perform NG31 - gage test (chapter 2, section VII).

Test 1. Test coolant temperature gage operation.

- Step 1. Disconnect lead 33 from coolant temperature sending unit.
- Step 2. Turn accessory/ignition switch to ON position.
- Step 3. Coolant temperature gage should read minimum temperature.
- Step 4. Touch contact end of lead 33 to frame ground. Coolant temperature gage should read maximum temperature.
- Step 5. If coolant temperature gage operates properly go to test 3 and check sending unit.
- Step 6. If coolant temperature gage does not operate properly, go to test 2.

Test 2. Test for battery voltage into temperature gage, go to malfunction 29, test 2.

Test 3. Test temperature sending unit.

- Step 1. Allow coolant to cool.
- Step 2. Set multimeter to RX1 scale.
- Step 3. Start engine (TM 9-2320-361-10).
- Step 4. Connect multimeter negative lead to engine ground and positive lead to sending unit. Multimeter reading should decrease as engine coolant temperature increases.
  - a. If resistance does not show any decrease as temperature increases, replace temperature sending unit (para. 4-24).
  - b. If resistance does show a decrease as temperature increases, go to test 4.

Test 4. Check continuity of lead 33.

- Step 1. Disconnect lead 33 from temperature gage.
- Step 2. Set multimeter to RX1 scale.
- Step 3. Touch negative lead of multimeter to contact end of lead 33 at sending unit.
- Step 4. Touch positive lead of multimeter to other end of lead 33.
  - a. If continuity is not present, replace or repair lead 33 (para. 4-51).
  - b. If continuity is present, replace temperature gage (para. 4-12).

END OF TESTING!

Table 2-4. Electrical Troubleshooting (Contd).

MALFUNCTION	TEST OR INSPECTION	CORRECTIVE ACTION
-------------	--------------------	-------------------

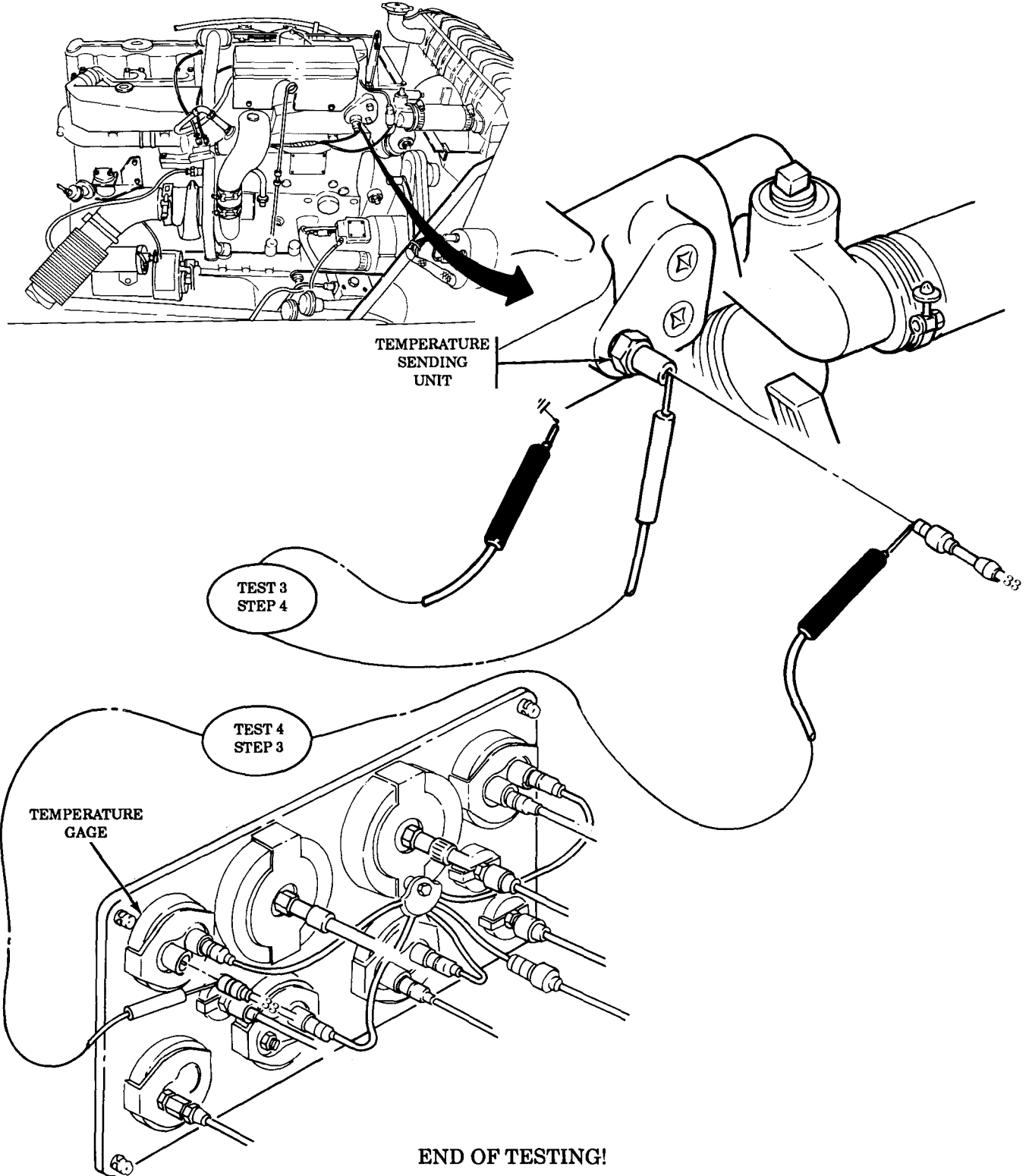



Table 2-4. Electrical Troubleshooting (Contd).

MALFUNCTION	TEST OR INSPECTION	CORRECTIVE ACTION
-------------	--------------------	-------------------

**31. FUEL GAGE INOPERATIVE****WARNING**

Do not perform testing near fuel tank with fill cap or sending unit removed. Fuel may ignite causing injury to personnel.

**NOTE**

- Ensure fuel tank is not empty before proceeding to test 1.
- If STE/ICE is available, perform NG31 - gage test (chapter 2, section VII).

Test 1. Test for battery voltage to fuel level sending unit.

Step 1. Disconnect lead 28 from fuel level sending unit.

Step 2. Set multimeter to a voltage range that will measure 24 Vdc.

Step 3. Connect negative lead to frame ground and touch positive lead to contact end of lead 28.

- a. If battery voltage is present, go to test 2.
- b. If battery voltage is not present, go to test 3.

Test 2. Test fuel gage operation.

Step 1. Turn accessory/ignition switch to OFF position.

Step 2. With lead 28 already disconnected from sending unit, touch contact end to frame ground.

Step 3. Turn accessory/ignition switch to ON position.

Step 4. Fuel gage should read "EMPTY."

- a. If fuel gage shows "EMPTY," go to step 5.
- b. If fuel gage does not show "EMPTY", replace fuel gage (para. 4-12).

Step 5. Lift lead 28 from frame ground. Fuel gage should now read "FULL."

- a. If fuel gage shows FULL, it is operational. Remove fuel level sending unit (para. 4-26) and go to test 5.
- b. If fuel gage does not show FULL, replace fuel gage (para. 4-12).

Test 3. Test fuel gage voltage.

Go to malfunction 29, test 2, and check battery voltage into fuel gage.

Test 4. Test continuity of lead 28.

Step 1. Turn accessory/ignition switch to OFF position.

Step 2. Disconnect lead 28 from fuel gage and from fuel level sending unit.

Step 3. Connect jumper wire from fuel level sending unit end of lead 28 to frame ground.

Step 4 Set multimeter to RX1 scale.

Step 5. Connect negative lead of multimeter to frame ground and touch positive lead of multimeter to contact end of lead 28.

- a. If continuity is present, reconnect lead 28 and recheck fuel gage operation.
- b. If continuity is not present, replace or repair wiring (para. 4-51).

Table 2-4. Electrical Troubleshooting (Contd).

MALFUNCTION	TEST OR INSPECTION	CORRECTIVE ACTION
-------------	--------------------	-------------------

Test 5. Test continuity of fuel level sending unit.

Step 1. Set multimeter to RX1 scale.

Step 2. Connect multimeter leads to fuel level sending unit.

Step 3. Position float in empty position.

a. If resistance is between 0.00 and 0.50 ohms, go to step 4.

b. If resistance is not between 0.00 and 0.50 ohms, replace fuel level sending unit (para. 4-26).

Step 4. Set multimeter to RX10 scale.

Step 5. Position float in full position.

a. If resistance is between 29.50 and 31.50 ohms, reinstall fuel level sending unit (para. 4-26) and recheck gage operation.

b. If resistance is not between 29.50 and 31.50 ohms. replace fuel level sending unit (para. 4-26).

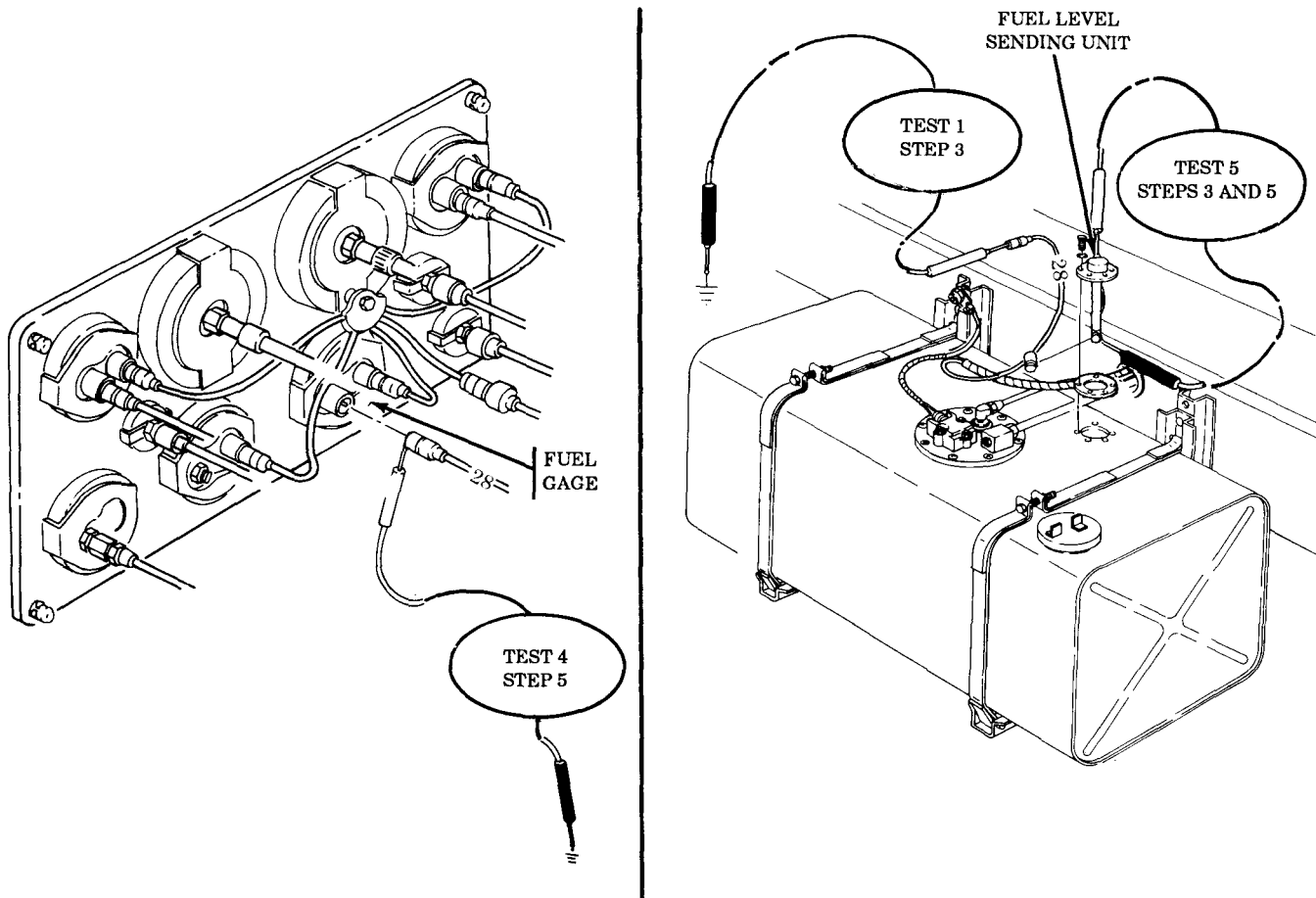

END OF TESTING!

Table 2-4. Electrical Troubleshooting (Contd).

MALFUNCTION	TEST OR INSPECTION	CORRECTIVE ACTION
-------------	--------------------	-------------------

**32. OIL PRESSURE GAGE INOPERATIVE**

**NOTE**

If STE/ICE is available, perform NG31 - gage test (chapter 2, section VII).

Test 1. Test oil pressure gage operation.

- Step 1. Disconnect lead 36 at oil pressure sending unit.
- Step 2. Turn accessory/ignition switch to ON position.
- Step 3. Oil pressure gage should show MINIMUM pressure.
- Step 4. Touch contact end of lead 36 to frame ground. Oil pressure gage should show MAXIMUM pressure.
  - a. If oil pressure gage operates properly, go to test 3.
  - b. If oil pressure gage does not operate properly, go to test 2.

Test 2. Test battery voltage to oil pressure gage, go to malfunction 29, test 2.

Test 3. Test oil pressure sending unit.

- Step 1. Set multimeter to RX1 scale.
- Step 2. Connect negative lead to frame ground on engine.
- Step 3. Touch positive lead to contact of oil pressure sending unit. Resistance should measure less than 1 ohm with engine off (no oil pressure).
- Step 4. If resistance is 1 ohm or more, replace oil pressure sending unit (para. 4-23).
- Step 5. If resistance is less than 1 ohm, continue with step 6.
- Step 6. Remove oil pressure sending unit (para. 4-23).
- Step 7. Install mechanical gage.
- Step 8. Start engine and check oil pressure on gage.
  - a. If oil pressure is 10 psi or above at idle, replace oil pressure sending unit (para. 4-23).
  - b. If oil pressure is less than 10 psi at idle, notify your supervisor.

Test 4. Test continuity of lead 36.

- Step 1. Disconnect lead 36 from oil pressure gage (warm engine).
- Step 2. Set multimeter to RX1 scale.
- Step 3. Touch positive lead of multimeter to one end of lead 36 and negative lead of multimeter to other end of lead 36.
  - a. If continuity is not present, replace or repair lead 36 (para. 4-51).
  - b. If continuity is present, replace oil pressure gage (para. 4-12).

Table 2-4. Electrical Troubleshooting (Contd).

MALFUNCTION	TEST OR INSPECTION	CORRECTIVE ACTION
-------------	--------------------	-------------------

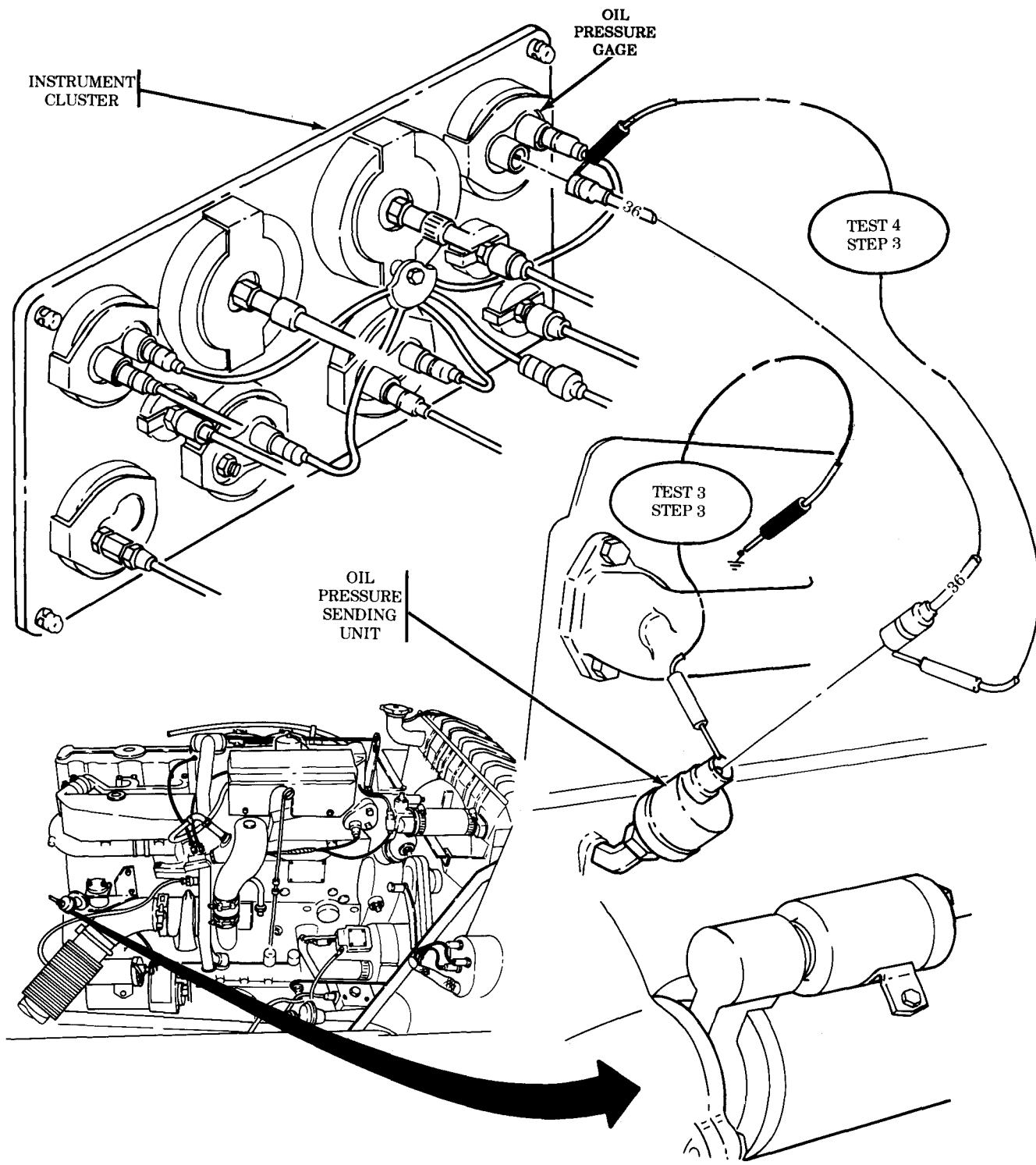

END OF TESTING!

Table 2-4. Electrical Troubleshooting (Contd).

MALFUNCTION TEST OR INSPECTION CORRECTIVE ACTION
--

**33. GENERATOR GAGE INOPERATIVE**

**NOTE**

If STE/ICE is available, perform NG31 - gage test (chapter 2, section VII).

Test 1. Test generator gage.

Step 1. Turn accessory/ignition switch to ON position. Do not start engine.

Step 2. Generator indicator should rest between lower edge of GREEN area and upper edge of YELLOW area on gage (24 volts).

Step 3. Start engine (TM 9-2320-361-10) and observe generator gage on instrument cluster.

Step 4. Generator gage should rise as engine speeds up and stop over white dot in green area (approximately 28.0 Vdc).

If generator gage does not perform as specified in steps 2 and 4 above, stop engine and go to test 2.

Test 2. Test battery voltage to generator, go to malfunction 29, test 2.

Check frame ground to multimeter.

- a. Set multimeter to RX1 scale.
- b. Connect negative lead to panel ground on instrument cluster.
- c. Touch positive lead to generator gage bracket. Continuity should be present. Ensure instrument panel is grounded.
- d. If continuity is present, reinstall instrument cluster (para. 4-12) and recheck gage operation.
- e. If continuity is not present, remove generator (para. 4-3 or 14-50) and check for corrosion around generator body.

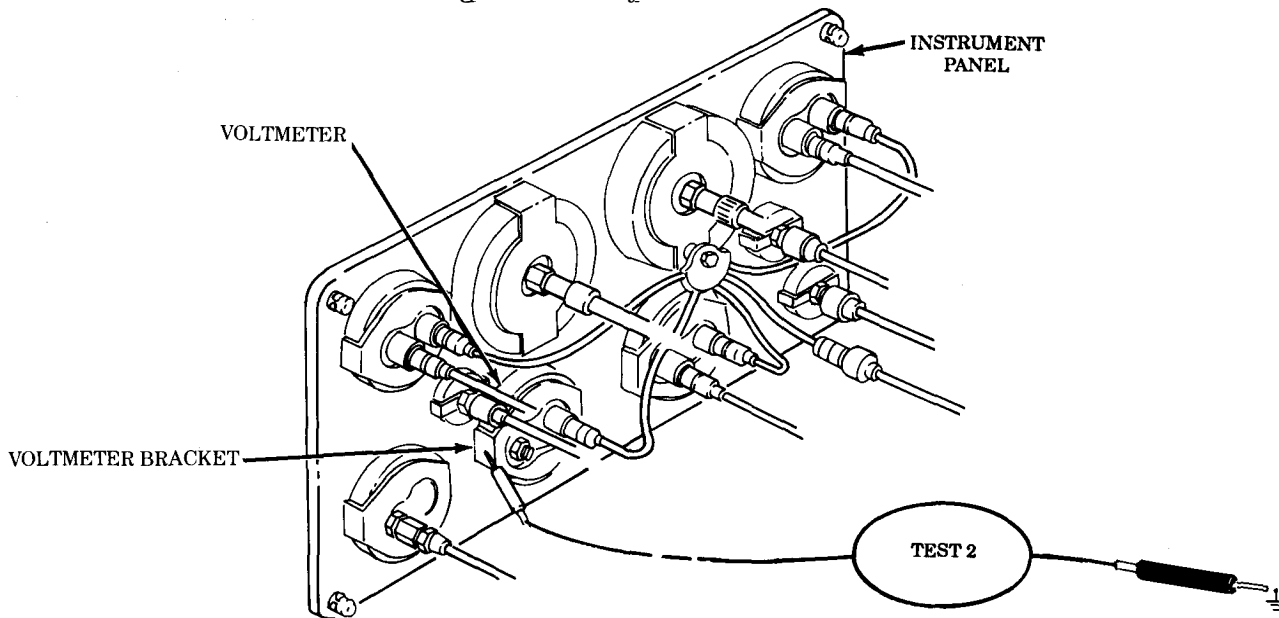

END OF TESTING!

Table 2-4. Electrical Troubleshooting (Contd).

MALFUNCTION	TEST OR INSPECTION	CORRECTIVE ACTION
-------------	--------------------	-------------------

**34. IN-TANK FUEL PUMP INOPERATIVE**

Test 1. Check for fuel pump operation.

Step 1. Turn accessory/ignition switch to ON position.

Step 2. Listen or feel for fuel pump humming or vibration at top of pump.

Step 3. If vibration can be felt or heard, go to test 4.

Step 4. If no vibration can be felt or heard, go to test 2.

Test 2. Test input voltage and ground to fuel pump.

Step 1. Remove lead 654 from fuel pump.

Step 2. Set multimeter to a voltage scale that will measure 24 Vdc.

Step 3. Connect positive lead of multimeter to lead 654 and negative lead of multimeter to ground lead 79.

a. If battery voltage is not present, go to test 5.

b. If battery voltage is present, go to test 3.

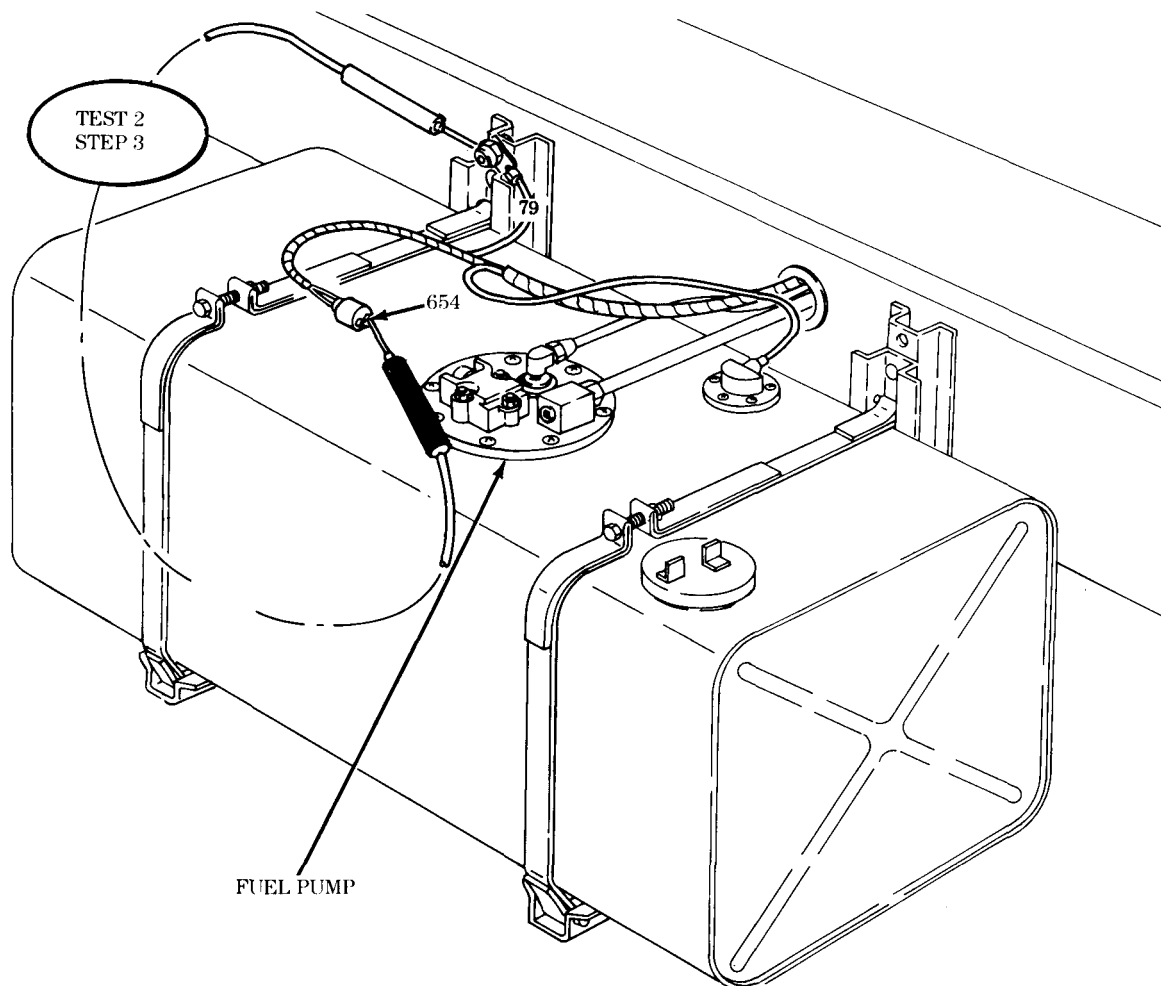

Table 2-4. Electrical Troubleshooting (Contd).

MALFUNCTION	TEST OR INSPECTION	CORRECTIVE ACTION
-------------	--------------------	-------------------

Test 3. Test in-tank fuel pump fuse.

Step 1. Turn accessory/ignition switch to OFF position.

Step 2. Remove fuse holder (para. 3-23).

Step 3. With multimeter set to RX1 scale, check continuity of fuse. Attach negative lead to one side of fuse. Touch positive lead to other side of fuse.

a. If continuity is not found, replace fuse (para. 3-23).

b. If continuity is present in fuse, go to test 4.

Test 4. Test fuel pressure delivered by in-tank fuel pump with engine stopped.

Go to table 2-2, malfunction 2, step 5.

Test 5. Test continuity of lead 654.

Step 1. Disconnect negative battery cable (para. 4-48).

Step 2. Disconnect lead 74 from start switch and disconnect lead 654 from fuel pump.

Step 3. Set multimeter to RX1.

Step 4. Connect negative and positive leads of multimeter between lead 74 and lead 654.

a. If continuity is not present, replace or repair leads 74 and 654.

b. If continuity is present, reconnect leads 74 and 654 and recheck fuel pump for proper operation.

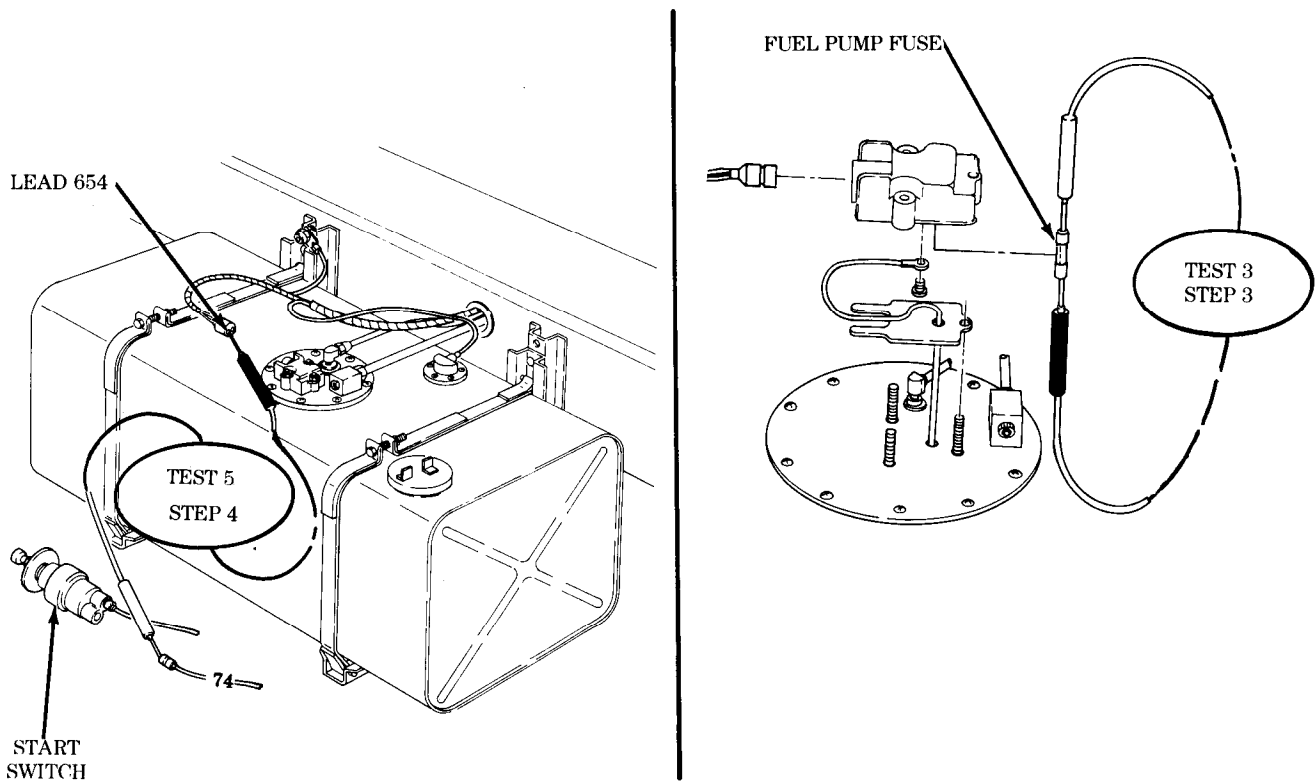

END OF TESTING!

Table 2-4. Electrical Troubleshooting (Contd).

MALFUNCTION	TEST OR INSPECTION	CORRECTIVE ACTION
-------------	--------------------	-------------------

**35. FRONT WHEEL DRIVE INDICATOR LIGHT INOPERATIVE**

Test 1. Test lamp.

Step 1. Disconnect lead 27A from indicator lamp.

Step 2. Set multimeter to RX1.

Step 3. Touch positive lead of multimeter to input pin of indicator lamp and negative lead to frame ground.

a. If continuity is present, go to test 2.

b. If continuity is not present, replace indicator lamp (para. 4-36).

Test 2. Test front wheel drive indicator lamp input voltage.

Step 1. Disconnect lead 27A from indicator lamp.

Step 2. Set multimeter to a voltage range that measures 24 Vdc.

Step 3. Connect multimeter positive lead to 27A and negative lead to frame ground.

a. If voltage is present, reconnect and go to test 4.

b. If voltage is not present, go to test 3.

Test 3. Test input voltage to front wheel drive lock-in switch.

Step 1. Remove lead 27A from pin A of lock-in switch.

Step 2. Connect negative lead of multimeter to frame ground.

Step 3. Touch positive lead of multimeter to lead 27A. Voltage of 24 Vdc should be present.

a. If voltage is present, replace lock-in switch (para. 4-36).

b. If voltage is not present, replace or repair lead 27A (para. 4-51).

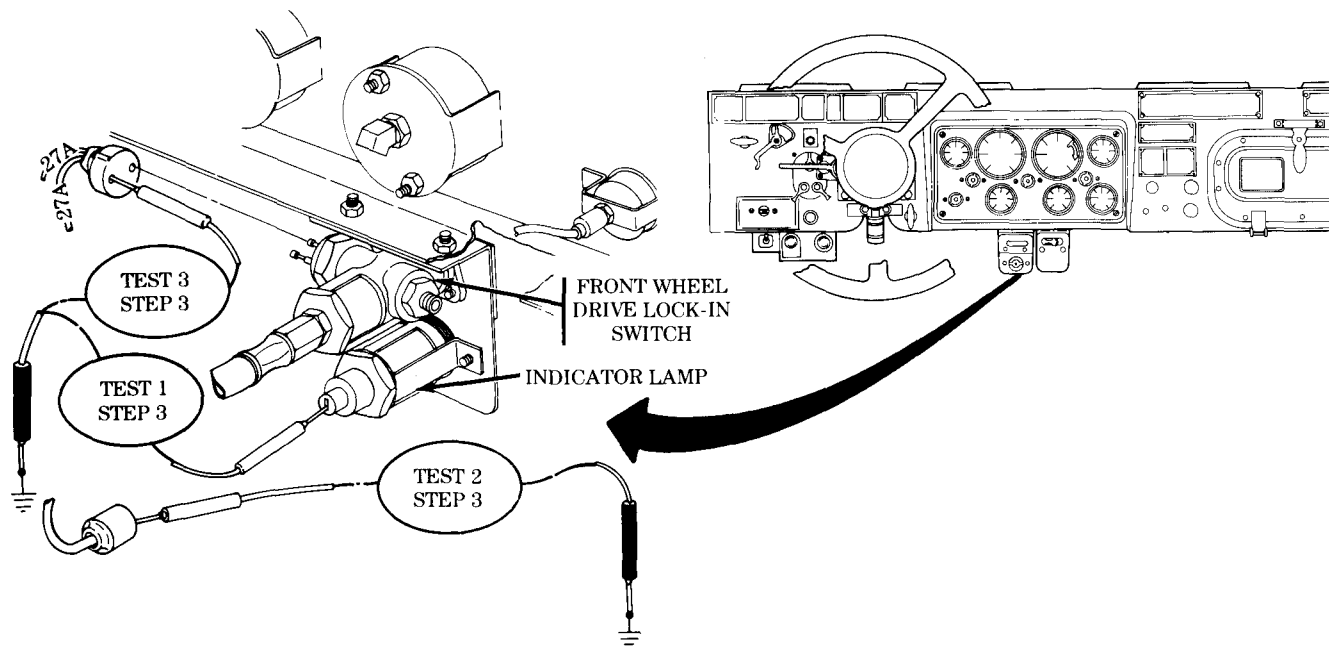

**END OF TESTING!**



Table 2-4. Electrical Troubleshooting (Contd).

MALFUNCTION TEST OR INSPECTION	CORRECTIVE ACTION
-----------------------------------	-------------------

**36. LOW AIR PRESSURE WARNING SYSTEM INOPERATIVE**

Test 1. Test input voltage to buzzer.

- Step 1. Turn accessory/ignition switch to OFF position.
- Step 2. Disconnect lead 85 from buzzer.
- Step 3. Drain air pressure from air tanks to less than 54 psi (TM 9-2320-361-10). Close petcock.
- Step 4. Set multimeter to a voltage range that will measure 24 Vdc.
- Step 5. Turn accessory/ignition switch to ON position.
- Step 6. Connect negative lead to frame ground.
- Step 7. Touch positive lead to contact end of lead 85.
  - a. If voltage is present, replace low air pressure buzzer (para. 4-27).
  - b. If voltage is not present, go to test 2.

Test 2. Test continuity of low air pressure switch.

- Step 1. Turn accessory/ignition switch to OFF position.
- Step 2. Disconnect lead 85 from pin B of low air pressure switch.
- Step 3. Turn accessory/ignition switch to ON position.
- Step 4. Connect negative lead of multimeter to frame ground. Connect positive lead of multimeter to pin B of low air switch. Battery voltage should be present.
  - a. If voltage is not present, go to test 3.
  - b. If voltage is present, check continuity of lead 85 connected between pin B of low air switch and buzzer.

Test 3. Test voltage into low air switch.

- Step 1. Disconnect lead 85 at pin A of low air switch.
- Step 2. Set multimeter to a voltage range that will measure 24 Vdc.
- Step 3. Connect negative lead to frame ground and touch positive lead to contact end lead 85.
  - a. If voltage is not present, repair or replace lead 85.
  - b. If voltage is present, replace low air buzzer (para. 4-27).

Table 2-4. Electrical Troubleshooting (Contd).

MALFUNCTION	TEST OR INSPECTION	CORRECTIVE ACTION
-------------	--------------------	-------------------

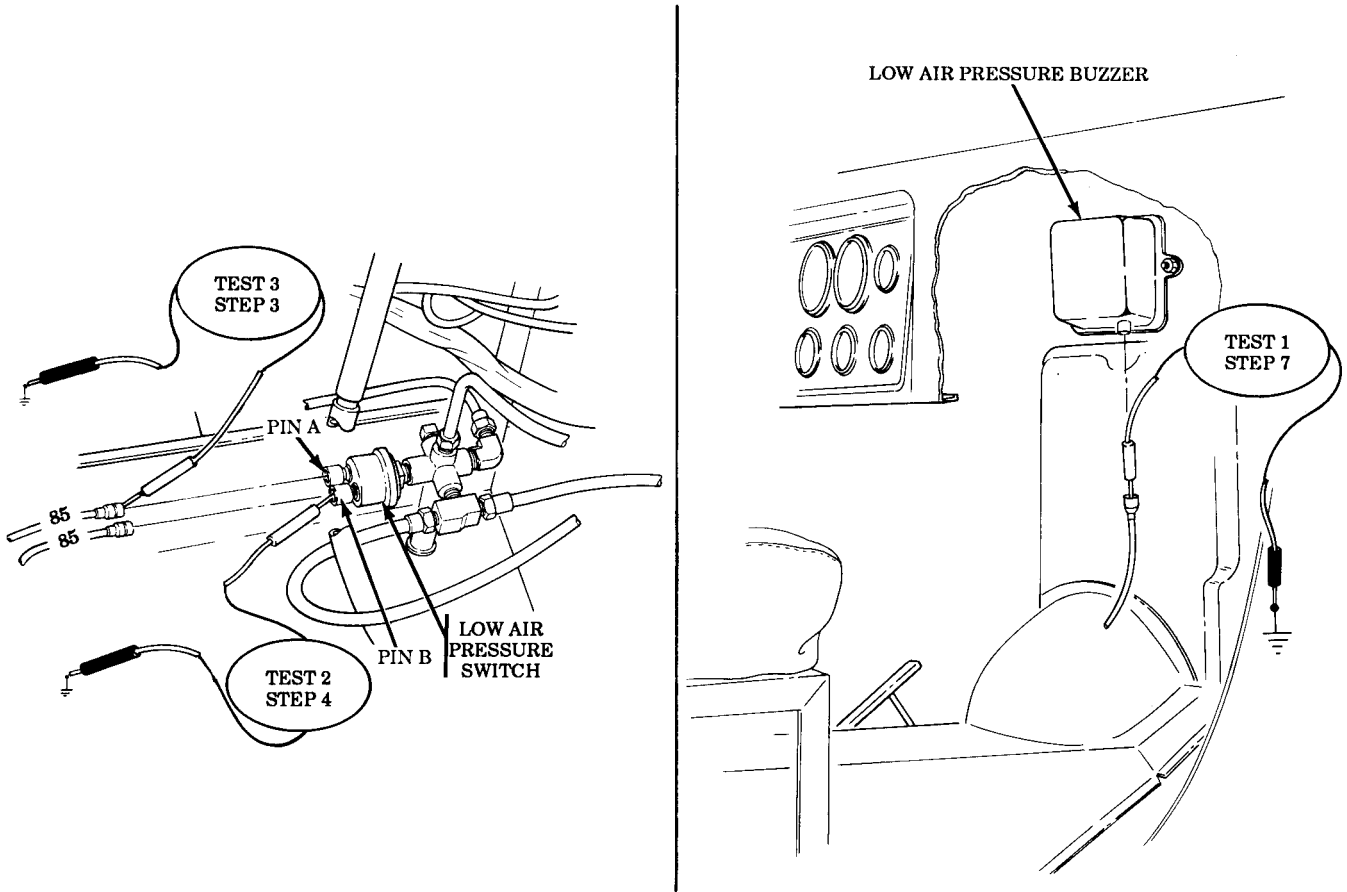

END OF TESTING!

**37. LOW AIR PRESSURE WARNING SYSTEM DOES NOT COME ON BELOW 60 PSI AND DOES NOT GO OFF ABOVE 66 PSI**

Test low air pressure switch operation. Air pressure switch should open and close between 54 and 66 psi.

- Step 1. Turn accessory/ignition switch to OFF position.
- Step 2. Turn air reservoir draincock to left and drain reservoir (TM 9-2320-361-10) to less than 54 psi. Close draincock.
- Step 3. Turn accessory/ignition switch to ON position. Buzzer should operate.
- Step 4. Start engine (TM 9-2320-361-10) and allow air pressure to buildup in air reservoir. Warning buzzer should turn off at 66 psi and above.
- Step 5. If air pressure switch fails either test in step 3 or 4, replace air pressure switch (para. 4-25).

END OF TESTING!

Table 2-4. Electrical Troubleshooting (Contd).

MALFUNCTION	TEST OR INSPECTION	CORRECTIVE ACTION
-------------	--------------------	-------------------

**38. HORN DOES NOT OPERATE**

**NOTE**

Electrical troubleshooting of the electric horn or air horn is the same.

Test 1. Test input voltage to horn circuit breaker.

- Step 1. Turn main light switch to SERVICE DRIVE position. If headlights light, there is voltage at input of horn circuit breaker; turn headlights OFF.
- Step 2. Remove lead 25 from horn circuit breaker.
- Step 3. Set multimeter to a voltage range that will measure 24 Vdc.
- Step 4. Connect negative lead to frame ground.
- Step 5. Touch positive lead to horn circuit breaker contact.
  - a. If voltage is not present, replace horn circuit breaker (para. 4-33).
  - b. If voltage is present, go to test 2.

Test 2. Test air horn solenoid voltage.

- Step 1. Remove lead 25 from pin B of air horn solenoid.
- Step 2. Connect negative lead of multimeter to frame ground.
- Step 3. Touch positive lead to pin B of solenoid.
  - a. If voltage is present, go to test 3.
  - b. If voltage is not present, go to step 6.
- Step 4. Remove lead 25 connected to pin A of air horn solenoid. Connect negative lead to frame ground. Touch positive lead to contact end of lead 25.
  - a. If voltage is present, replace air horn solenoid (para. 4-31).
  - b. If voltage is not present, replace or repair lead 25.

Test 3. Test horn switch input voltage.

- Step 1. Remove horn button (para. 4-30) until lead 25 can be seen.
- Step 2. Set multimeter to a voltage range that will measure 24 Vdc.
- Step 3. Connect negative lead to frame ground.
- Step 4. Touch positive lead to lead 25 contact end
  - a. If voltage is not present, replace or repair lead 25 (para. 4-51).
  - b. If voltage is present, go to test 4.

Test 4. Test horn switch continuity.

- Step 1. Disconnect lead 25 from air horn solenoid to protect multimeter.
- Step 2. Reinstall horn button cap, spring, and contact (para. 4-30).
- Step 3. Set multimeter to RX1 scale.
- Step 4. Connect negative lead to a good frame ground.
- Step 5. Touch positive lead to lead 25 and press down until contact touches base plate.
  - a. If continuity is present, reconnect lead 25 and recheck horn operation.
  - b. If continuity is not present, remove horn button and clean or replace horn button (para. 4-30).

Table 2-4. Electrical Troubleshooting (Contd).

MALFUNCTION	TEST OR INSPECTION	CORRECTIVE ACTION
-------------	--------------------	-------------------

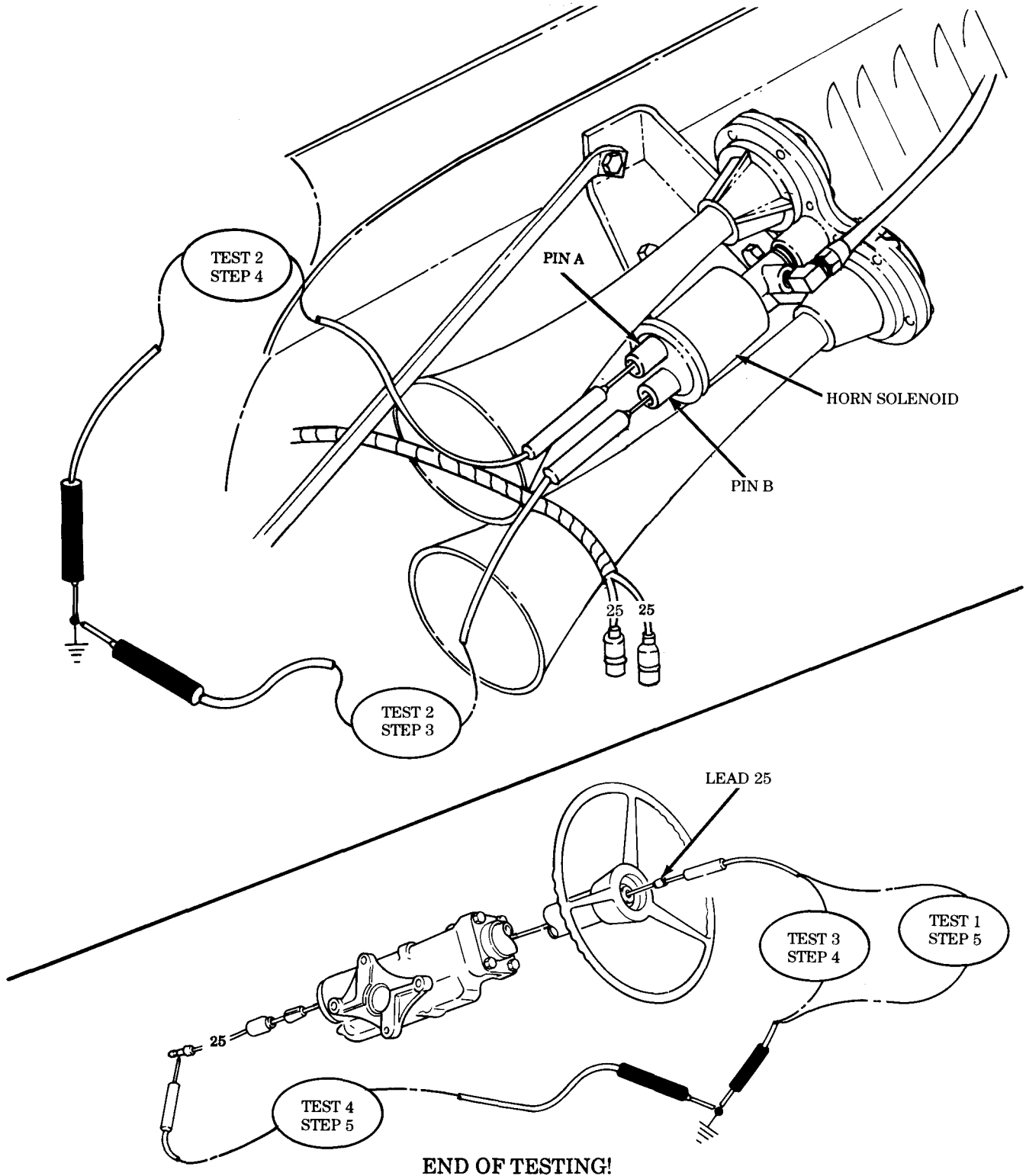

Table 2-4. Electrical Troubleshooting (Contd).

MALFUNCTION	TEST OR INSPECTION	CORRECTIVE ACTION
-------------	--------------------	-------------------

**HEATING SYSTEMS**

**39. ENGINE MANIFOLD HEATER DOES NOT WORK**

Test 1. Test engine manifold heater ignition circuit for battery voltage.

Step 1. Disconnect lead 55 from engine manifold heater ignition unit. Manifold heater fuel pump is now disabled.

Step 2. Set multimeter to a voltage range that will measure 24 Vdc.

Step 3. Turn accessory/ignition switch to ON position.

Step 4. Push manifold heater switch and hold.

Step 5. Touch positive lead of multimeter to contact end of lead 55 and negative lead to frame ground.

- a. If battery voltage is present, go to test 4.
- b. If battery voltage is not present, go to test 2.

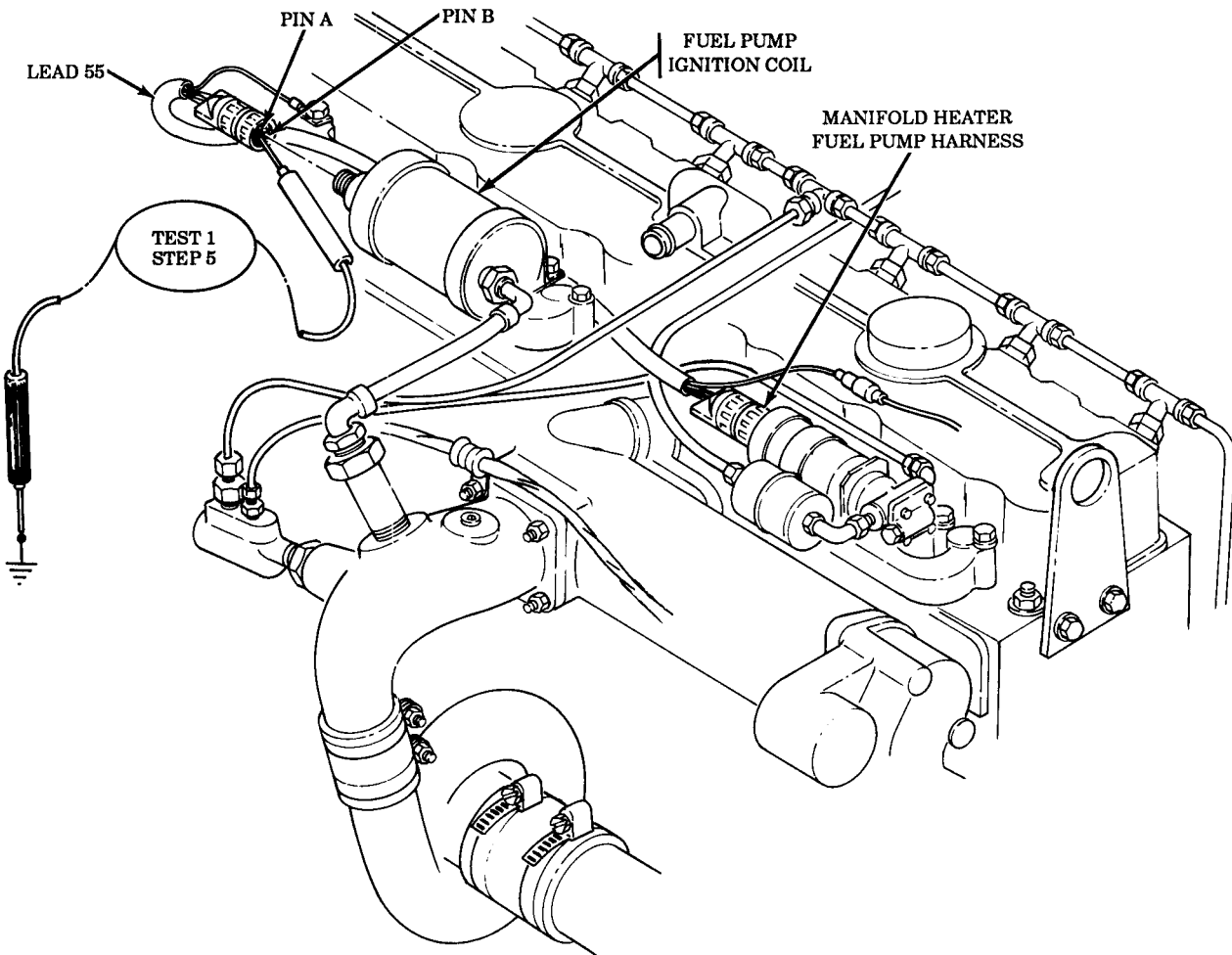

Table 2-4. Electrical Troubleshooting (Contd).

MALFUNCTION	TEST OR INSPECTION	CORRECTIVE ACTION
-------------	--------------------	-------------------

Test 2. Test input voltage to manifold heater switch.

Step 1. Disconnect lead 55 at switch input.

Step 2. Turn accessory/ignition switch to ON position.

Step 3. Connect negative lead of multimeter to frame ground.

Step 4. Touch positive lead of multimeter to contact end of lead 55.

a. If battery voltage is present, go to test 3.

b. If battery voltage is not present, go to malfunction 4, test 6.

Test 3. Test continuity of manifold heater switch.

Step 1. Turn accessory/ignition switch to OFF position.

Step 2. Disconnect lead 55 to manifold heater switch output.

Step 3. Set multimeter to RX1 scale.

Step 4. Connect negative lead to one side of switch and touch positive lead to other side. Push manifold heater switch.

a. If continuity is not present, replace manifold heater switch (para. 4-22).

b. If continuity is present, go to test 4.

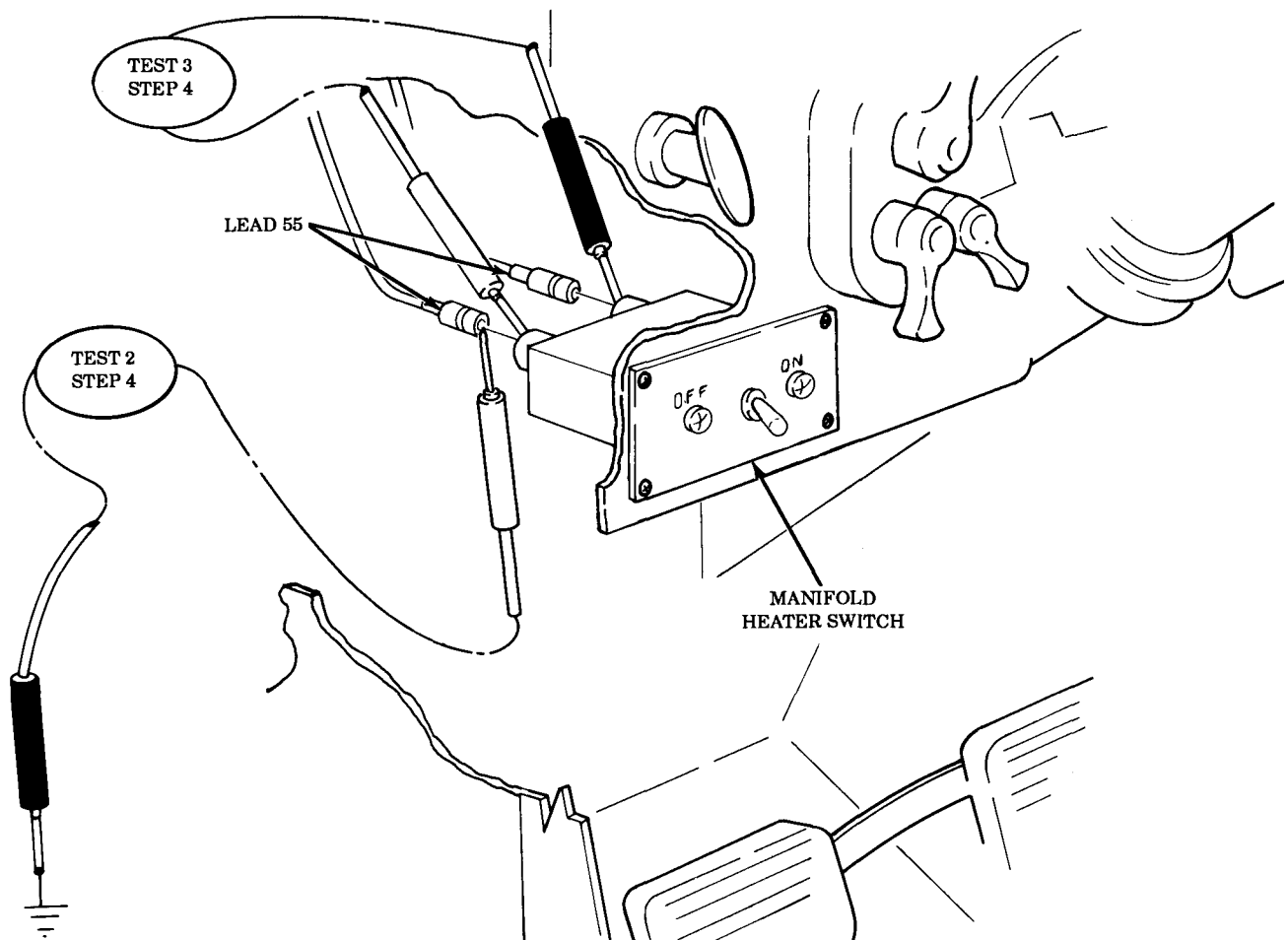

Table 2-4. Electrical Troubleshooting (Contd).

MALFUNCTION	TEST OR INSPECTION	CORRECTIVE ACTION
-------------	--------------------	-------------------

Test 4. Test manifold heater spark plug.

- Step 1. Remove manifold heater spark plug (para. 3-30 or 3-31).
- Step 2. Connect jumper wire from spark plug to engine ground.
- Step 3. Disconnect wiring harness from manifold heater fuel pump.
- Step 4. Turn accessory/ignition switch to ON position.
- Step 5. Position manifold heater switch to START.
  - a. If spark plug does not arc, replace spark plug (para. 3-30 or 3-31) and repeat test 4.
  - b. If retest of test 4 fails to produce an arc to engine ground, go to test 5.

Test 5. Test manifold spark plug cable.

- Step 1. Remove cable from manifold heater spark plug (para. 3-30 or 3-31).
- Step 2. Remove spark plug cable at ignition coil.
- Step 3. Set multimeter to RX1000 scale.
- Step 4. Touch multimeter negative lead to contact end of spark plug cable at the plug.
- Step 5. Touch multimeter positive lead to opposite end of spark plug cable.
  - a. Continuity should be present. If continuity is present, go to test 6.
  - b. If continuity is not present, replace or repair spark plug cable (para. 3-30 or 3-31).

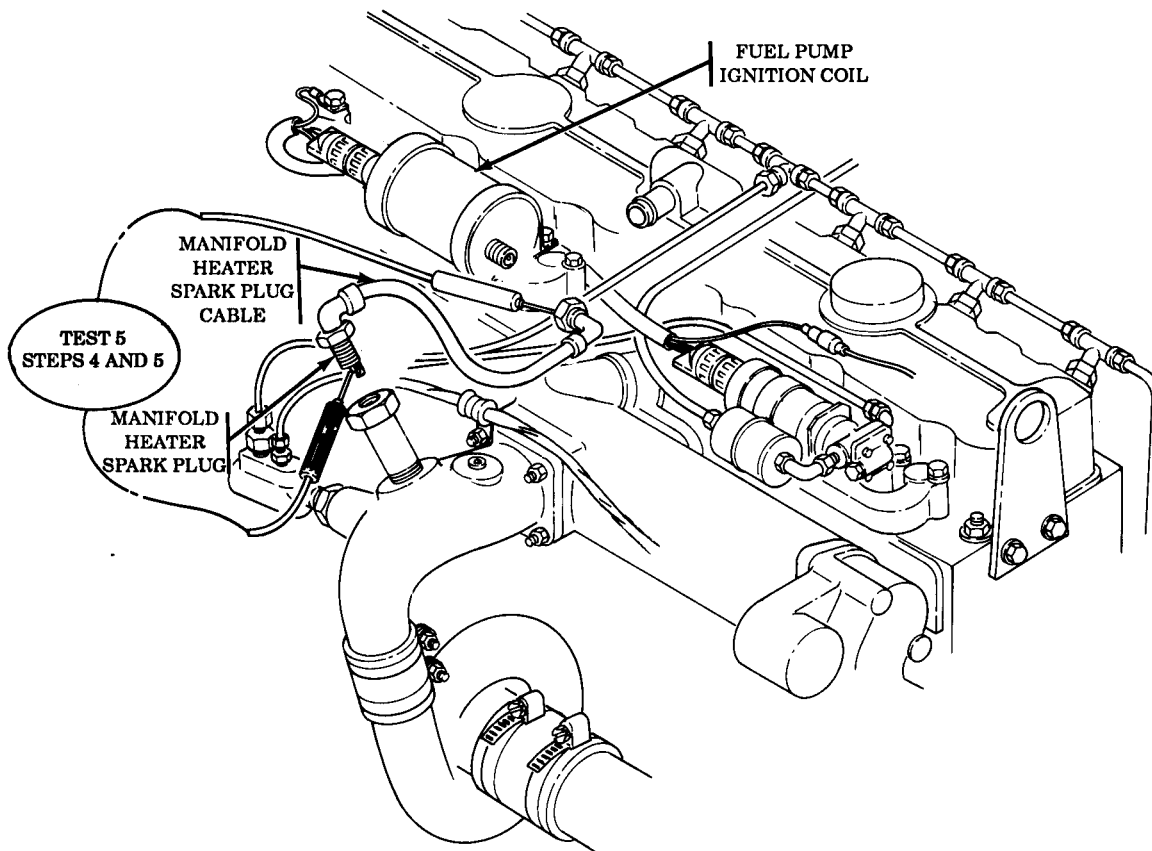

Table 2-4. Electrical Troubleshooting (Contd).

MALFUNCTION	TEST OR INSPECTION	CORRECTIVE ACTION
-------------	--------------------	-------------------

Test 6. Test continuity of ignition coil.

Step 1. Disconnect both input and output leads of ignition coil.

Step 2. Set multimeter to RX100 scale.

Step 3. Touch multimeter negative lead to pin sB (neg) of ignition coil.

Step 4. Touch multimeter positive lead to pin A (pos) of ignition coil.

a. Continuity should be present. If continuity is present, go to step 5.

b. If continuity is not present, replace ignition coil (para. 3-30 or 3-31).

Step 5. Test continuity of ignition coil output.

Step 6. Touch multimeter negative lead to pin B (neg) of ignition coil.

Step 7. Touch multimeter positive lead to contact end at ignition coil output.

a. If continuity is present, go to test 7.

b. If continuity is not present, replace ignition coil (para. 3-30 or 3-31).

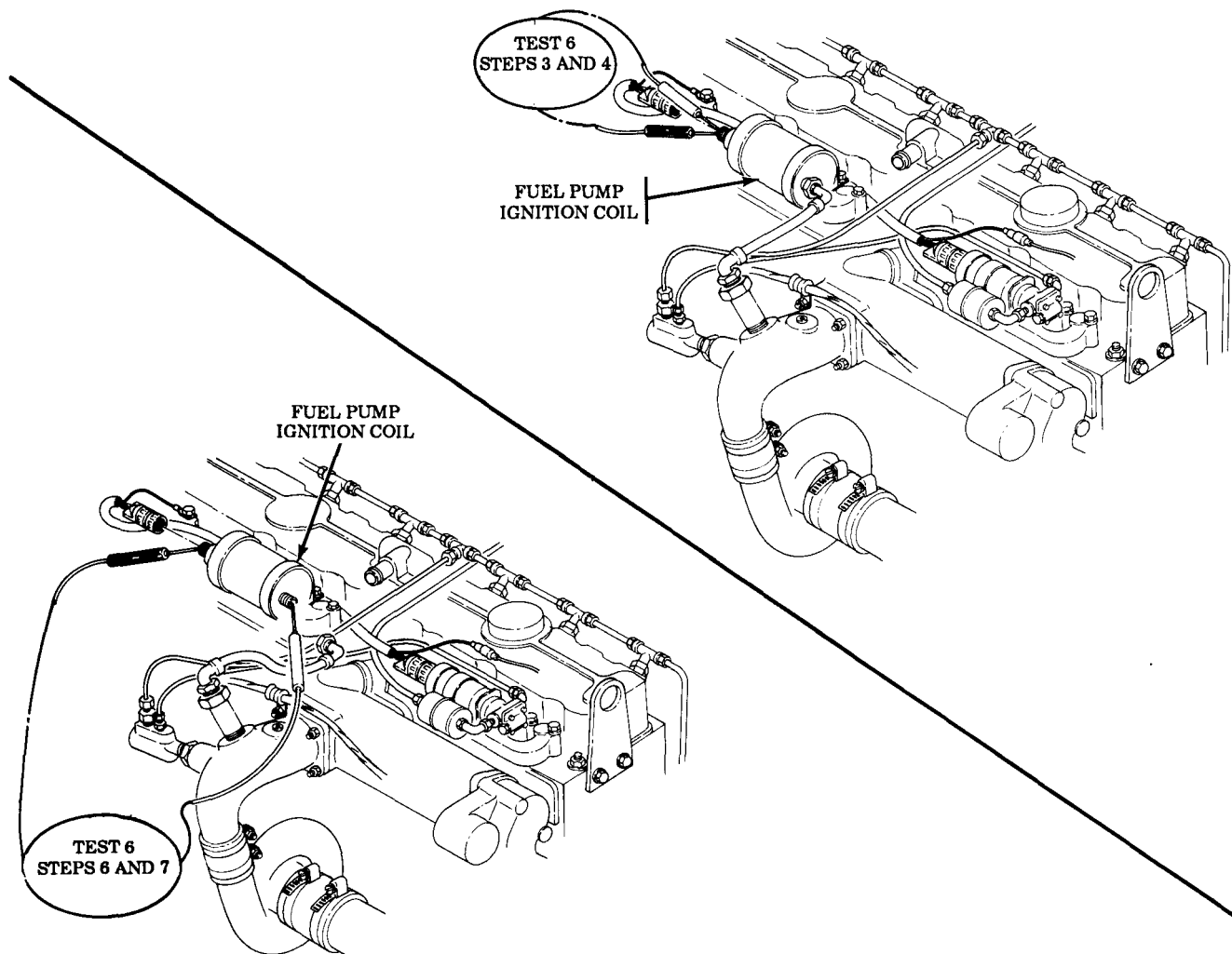



Table 2-4. Electrical Troubleshooting (Contd).

MALFUNCTION	TEST OR INSPECTION	CORRECTIVE ACTION
-------------	--------------------	-------------------

Test 7. Test fuel pump-to-ignition coil wiring harness.

Step 1. Disconnect wiring harness input from ignition coil.

Step 2. Set multimeter to 24 Vdc scale.

Step 3. Touch multimeter negative lead to pin B (neg) of wiring harness at ignition coil.

Step 4. Touch multimeter positive lead to pin A (pos) of wiring harness at ignition coil.

a. If voltage is present, go to test 9.

b. If voltage is not present, go to test 8.

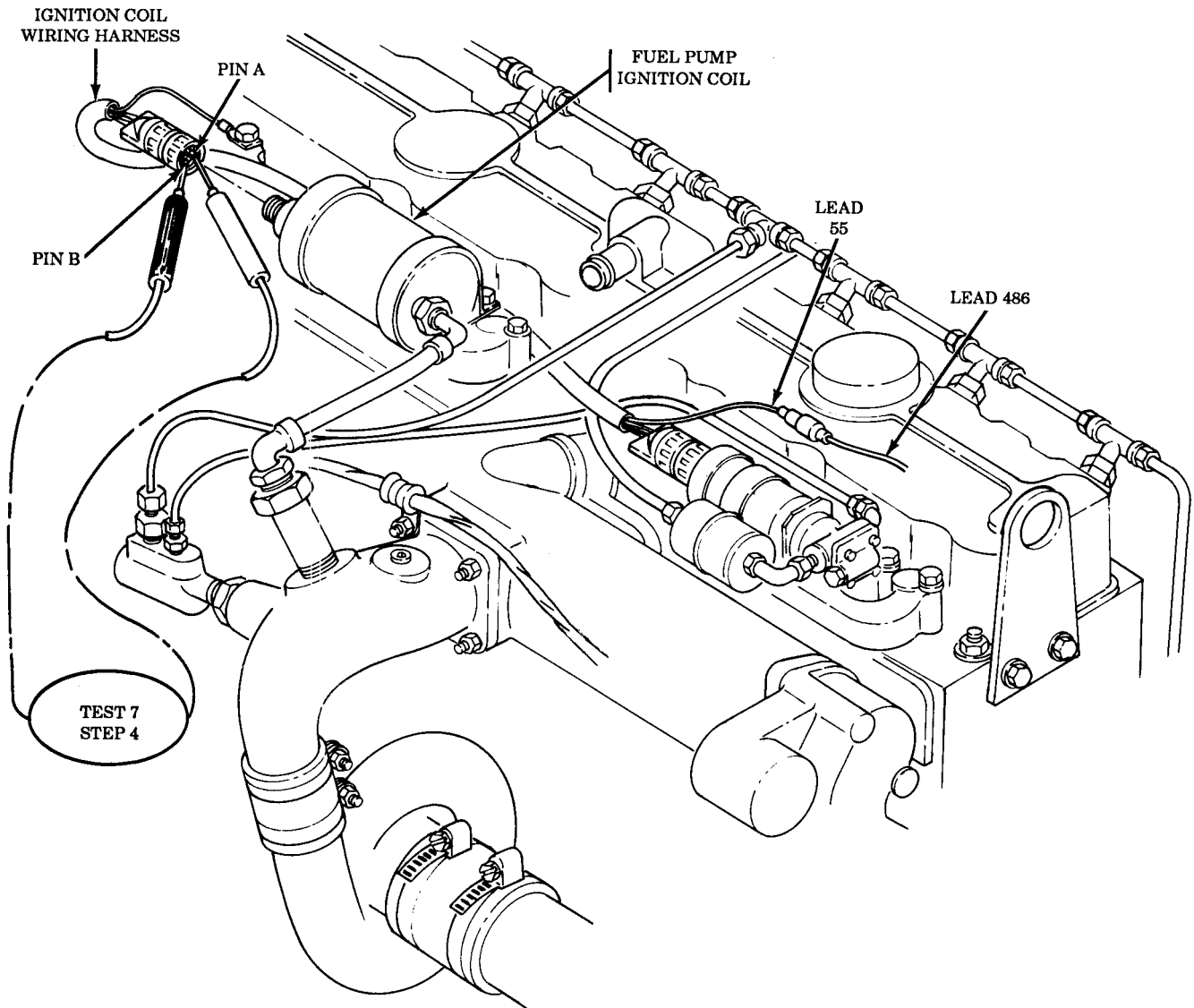

Table 2-4. Electrical Troubleshooting (Contd).

MALFUNCTION	TEST OR INSPECTION	CORRECTIVE ACTION
-------------	--------------------	-------------------

Test 8. Check continuity of ignition coil harness.

Step 1. Disconnect ignition coil harness from fuel pump and ignition coil.

Step 2. Set multimeter to RX1.

Step 3. Connect multimeter negative lead to lead 486 and multimeter positive lead to pin A.

a. If continuity is not present, repair harness (para. 4-51).

b. If continuity is present, go to test 9.

Test 9. Test manifold heater fuel system.

Refer to table 2-2, Mechanical Troubleshooting, malfunction 17, steps 2 through 4.

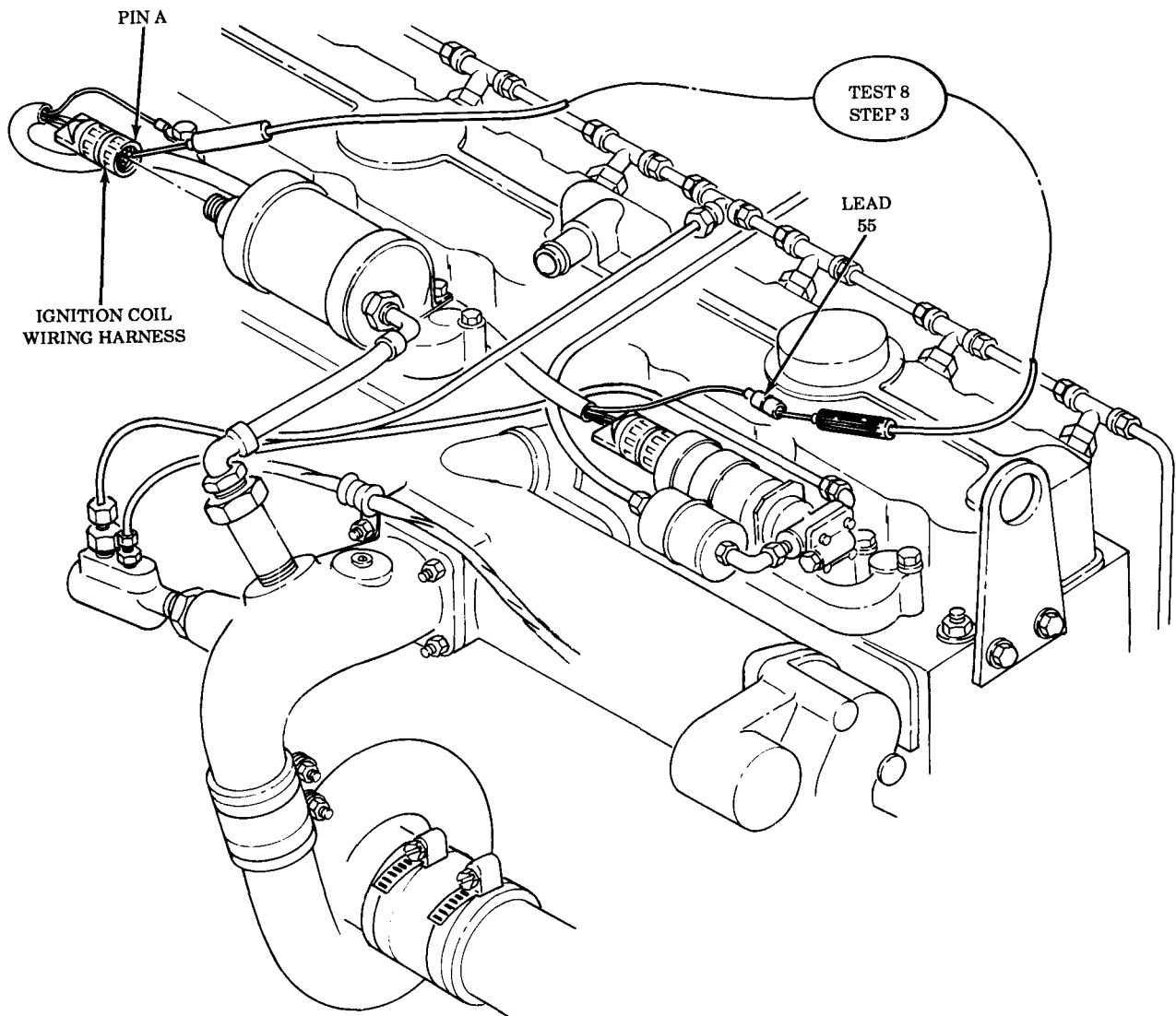

END OF TESTING!

Table 2-4. Electrical Troubleshooting (Contd).

MALFUNCTION	TEST OR INSPECTION	CORRECTIVE ACTION
-------------	--------------------	-------------------

**40. HOT WATER PERSONNEL HEATER DOES NOT OPERATE OR DOES NOT OPERATE IN LOW POSITION**

Test 1. Check horn operation.

Push horn button.

- a. If horn fails to operate, go to malfunction 38.
- b. If horn is operational, voltage is present at input of heater circuit breaker. Go to test 2.
- c. If heater high/low switch operates in high, but fails to operate in low, go to test 5.

Test 2. Check heater high/low switch for power input.

- Step 1. Set multimeter to a range that will measure 24 Vdc.
- Step 2. Disconnect lead 10 at rear of heater switch.
- Step 3. Touch multimeter positive lead to contact end of lead 10 at heater switch.
- Step 4. Touch multimeter negative lead to frame ground. Voltage should be present.
  - a. If voltage is present, go to test 3.
  - b. If voltage is not present, replace or repair lead 10 (para. 4-51).

Test 3. Test for power output at heater high/low switch,

- Step 1. Set multimeter to range that will measure 24 Vdc.
- Step 2. Disconnect lead 400 at rear of heater switch.
- Step 3. Touch positive lead of multimeter to contact end of power output at the heater switch.
- Step 4. Touch negative lead of multimeter to frame ground. Voltage should be present.
  - a. If voltage is present, go to test 4.
  - b. If voltage is not present, replace heater switch (para. 4-34).

Test 4. Test personnel heater for power input.

- Step 1. Ensure heater switch is in high position.
- Step 2. Set multimeter to a range that will measure 24 Vdc.
- Step 3. Disconnect lead 400 from personnel heater.
- Step 4. Touch multimeter positive lead to contact end of lead 400.
- Step 5. Touch multimeter negative lead to frame ground. Voltage should be present.
  - a. If voltage is not present, replace or repair lead 400 (para. 4-51).
  - b. If voltage is present, and personnel heater fails to operate, replace personnel heater (para. 11-42).

Test 5. Test blower motor resistor.

- Step 1. Set multimeter to RX1.
- Step 2. Ensure heater switch is set to low position.
- Step 3. Touch positive lead of multimeter to one lead on resistor.
- Step 4. Touch negative lead of multimeter to the other lead of resistor.
  - a. Multimeter should measure between 4.5 and 5.5 ohms.
  - b. If resistance is not within tolerance of 4.5 and 5.5 ohms, replace resistor (para. 4-35).

Table 2-4. Electrical Troubleshooting (Contd).

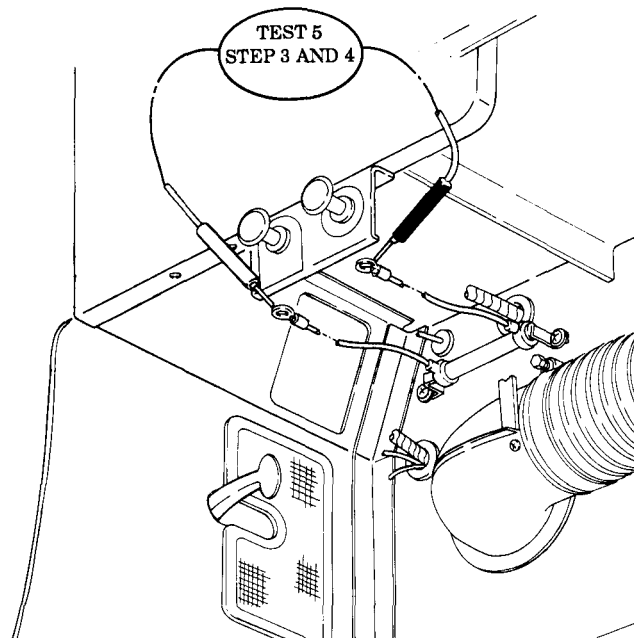
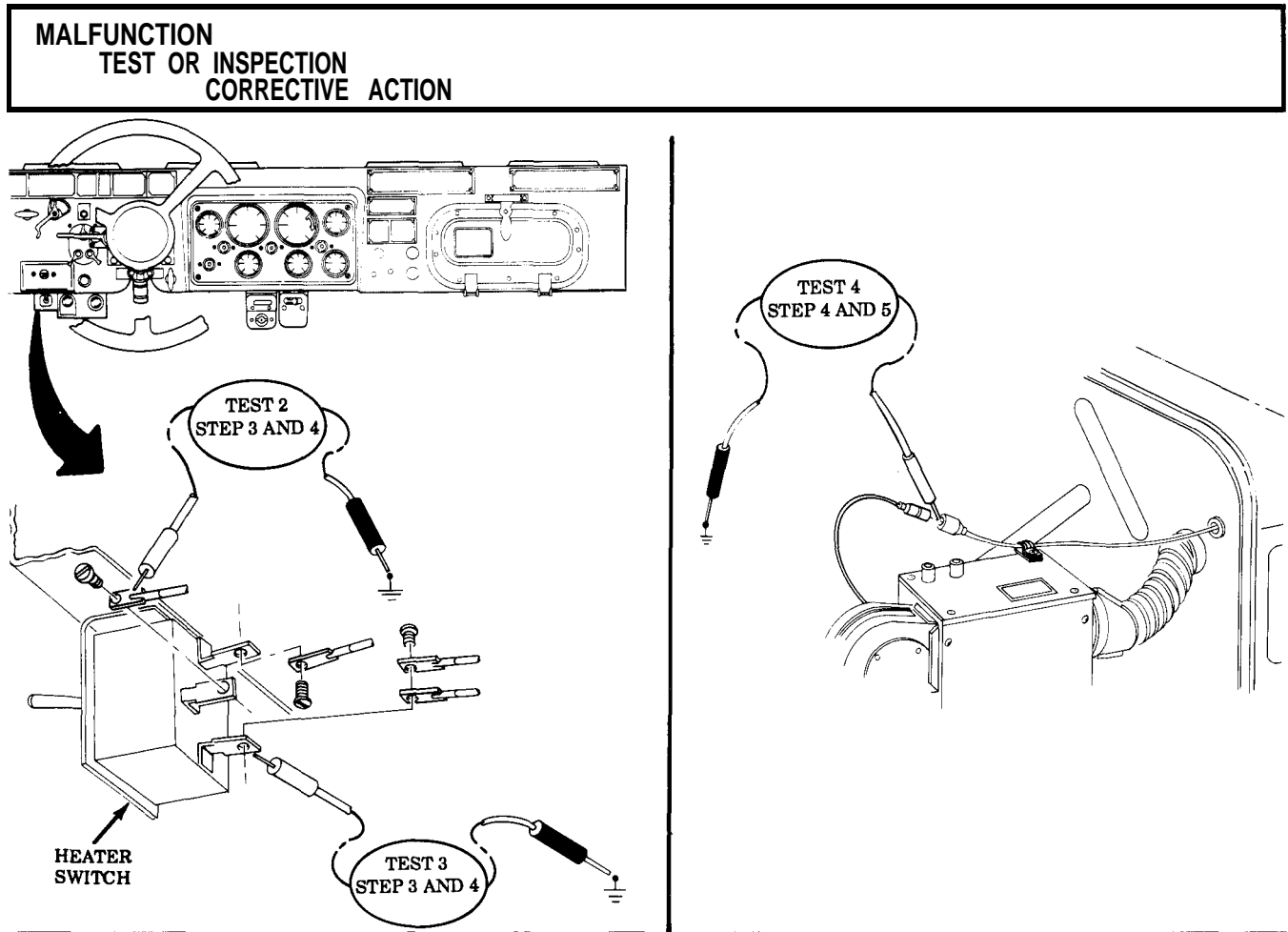

END OF TESTING!

Table 2-4. Electrical Troubleshooting (Contd).

MALFUNCTION	TEST OR INSPECTION	CORRECTIVE ACTION
-------------	--------------------	-------------------

**41. PERSONNEL FUEL BURNING HEATER INOPERATIVE**

Test 1. Check horn operation.

Push horn button.

- a. If horn is operational, voltage is present at input of personnel heater circuit breaker, go to test 2.
- b. If horn fails to operate, go to malfunction 38.

Test 2. Test lead 10 for power input to heater control box.

- Step 1. Set multimeter to a range that will measure 24 Vdc.
- Step 2. Disconnect lead 10 from heater control box.
- Step 3. Touch multimeter positive lead to contact end of lead 10.
- Step 4. Touch negative lead of multimeter to frame ground. Voltage should be present.
  - a. If voltage is present, go to test 3.
  - b. If voltage is not present, replace or repair lead 10 (para. 4-51).

Test 3. Check heater control box for power output.

- Step 1. Set multimeter to a range that will measure 24 Vdc.
- Step 2. Disconnect harness connector from rear of control box.
- Step 3. Set heater control switch to start and hold.
- Step 4. Set heater control heat switch to high.
- Step 5. Touch positive lead of multimeter to pin A
- Step 6. Touch negative lead of multimeter to frame ground.
- Step 7. Repeat steps 4 and 5 for pins B, C, and D. Voltage should be present.
  - a. If voltage is present at all pins tested, go to test 4.
  - b. If voltage is not present at one or more pins, replace heater control box (para. 14-3).

Test 4. Check for input power at fuel pump.

- Step 1. Set multimeter to a range that will measure 24 Vdc.
- Step 2. Disconnect lead 25 at fuel pump.
- Step 3. Touch multimeter positive lead to contact end of lead 25.
- Step 4. Touch multimeter negative lead to frame ground. Voltage should be present.
  - a. If voltage is present, replace personnel fuel burning heater (para. 14-2).
  - b. If voltage is not present, replace or repair lead 25 (para. 4-51).

Test 5. Check fuel pump for proper operation.

Refer to mechanical troubleshooting table 2-2, malfunction 82.

Test 6. Check for power input at personnel heater.

- Step 1. Set multimeter to a voltage that will measure 24 Vdc.
- Step 2. Disconnect harness connector at personnel heater.
- Step 3. Set heater control switch to run.
- Step 4. Touch multimeter positive lead to pin A of harness connector.
- Step 5. Touch multimeter negative lead to frame ground.

Table 2-4. Electrical Troubleshooting (Contd).

MALFUNCTION	TEST OR INSPECTION	CORRECTIVE ACTION
-------------	--------------------	-------------------

Step 6. Repeat steps 4 and 5 for pins B, C, and D. Voltage should be present at all pins tested.

- a. If voltage is present, replace personnel heater (para. 14-2).
- b. If voltage is not present at one or more pins, replace or repair harness (para. 4-51).

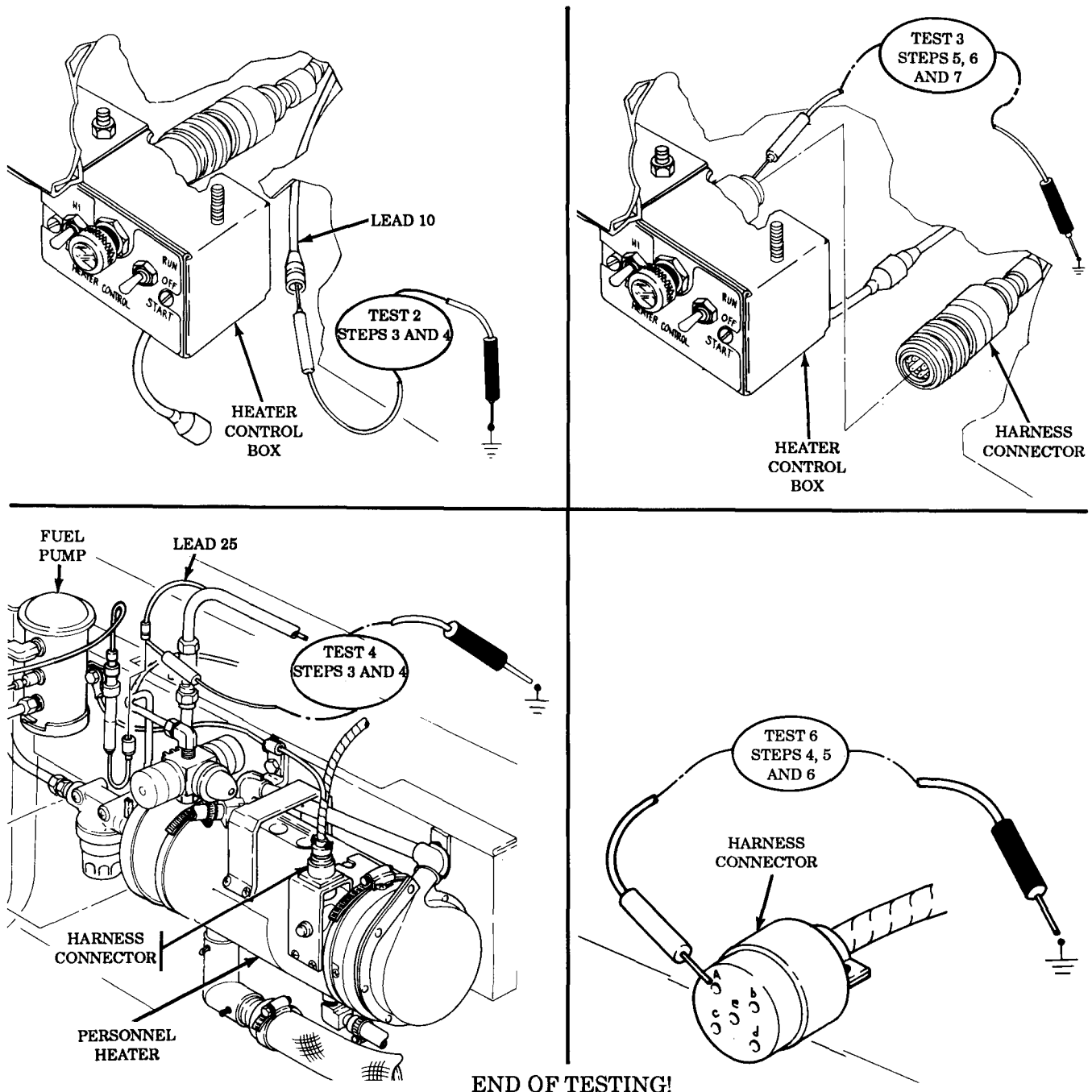

Table 2-4. Electrical Troubleshooting (Contd).

MALFUNCTION	TEST OR INSPECTION	CORRECTIVE ACTION
-------------	--------------------	-------------------

**42. HEATER CONTROL BOX LIGHT INOPERATIVE, BUT HEATER OPERATIVE**

Test 1. Check for voltage at heater control box indicator lamp.

- Step 1. Set multimeter to a voltage range that will measure 24 Vdc.
- Step 2. Position heater control switch to RUN.
- Step 3. Position heater switch to HIGH.
- Step 4. Remove heater control box indicator lamp.
- Step 5. Touch positive lead of multimeter to indicator lamp socket.
- Step 6. Touch negative lead of multimeter to frame ground.
  - a. If voltage is present, replace indicator lamp.
  - b. If voltage is not present, go to test 2.

Test 2. Check for voltage between personnel heater and heater control box.

- Step 1. Disconnect wiring harness at personnel heater.
- Step 2. Connect jumper wire from pin D to pin E at personnel heater.
  - a. If heater control box indicator lamp is lit, replace personnel heater (para. 14-2).
  - b. If indicator lamp fails to light, replace or repair wiring harness (para. 4-51).

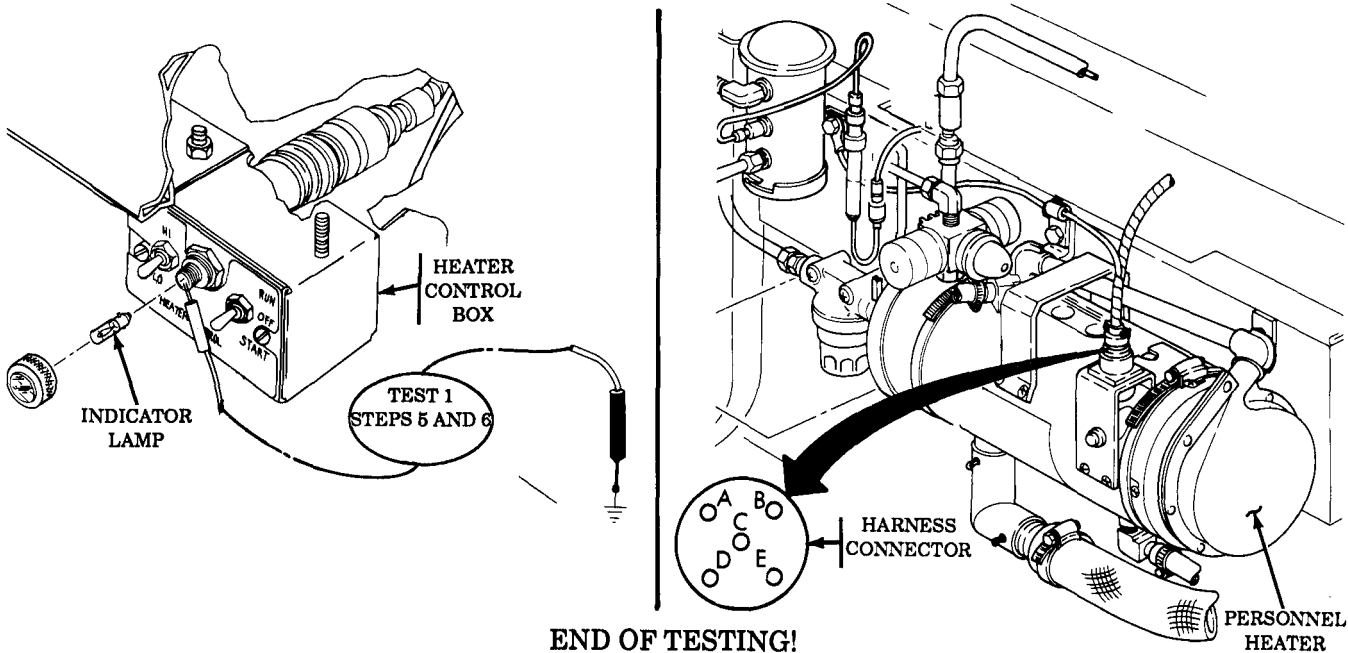

**TRAILER CONNECTION SYSTEM**

**43. ONE OR MORE TRAILER LIGHTS INOPERATIVE**

Test 1. Test trailer receptacle voltage.

- Step 1. Turn main light switch lever to position corresponding to inoperative lamp.

**NOTE**

For stoplight circuit test, brake pedal must be depressed and air pressure maintained.

- Step 2. Set multimeter to a voltage range that will measure 24 Vdc.

Table 2-4. Electrical Troubleshooting (Contd).

MALFUNCTION	TEST OR INSPECTION	CORRECTIVE ACTION
-------------	--------------------	-------------------

- Step 3. Connect negative lead of multimeter to trailer receptacle pin D. Touch positive lead to appropriate trailer receptacle pin of circuit being tested. Light switch must be in corresponding position.
- Battery voltage should be present at trailer receptacle being tested.
  - If battery voltage was present, disconnect and reconnect male connector to ensure positive connection. If trailer lamps still do not light, check male connection for corrosion. If trailer lamps still do not light, check trailer lighting system (TM 9-2320-213-14).
  - If battery voltage was not present at one or more of the pins being tested, continue with test 2.

Test 2. Test trailer receptacle ground.

Step 1. Set multimeter to RX1 scale.

Step 2. Connect negative lead of multimeter to frame ground. Touch positive lead to pin D of trailer receptacle.

- Continuity should be present.
- If continuity is not present, replace or repair lead 90 (para. 4-51).

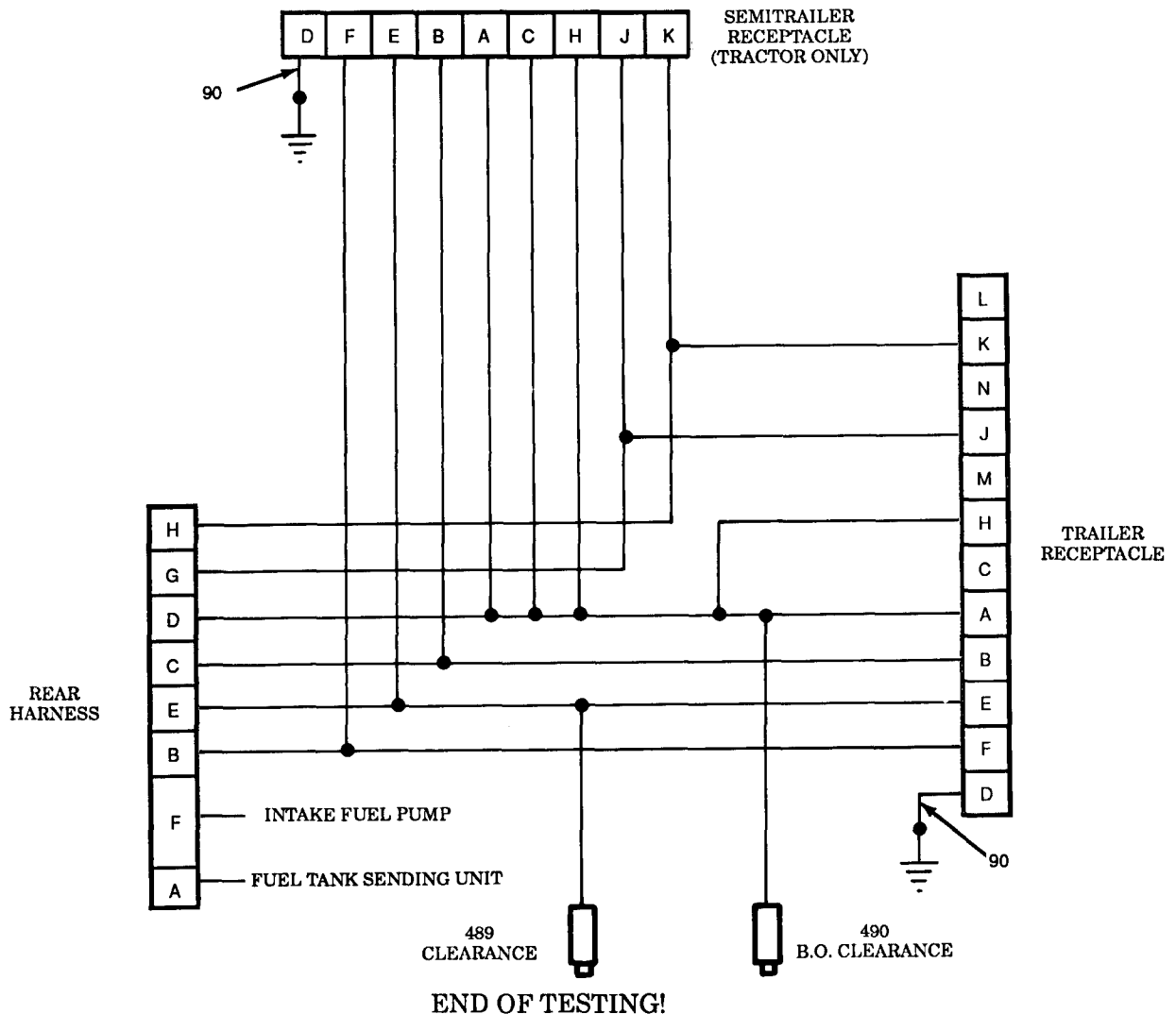



## Section VII. STE/ICE TROUBLESHOOTING (SIMPLIFIED TEST EQUIPMENT FOR INTERNAL COMBUSTION ENGINES)

### 2-16. GENERAL

a. This section is applicable only if STE/ICE is available. The section contains information and tests which may be used with STE/ICE to locate malfunctions that may develop in vehicle. Tests can be used during troubleshooting, PMCS, or after replacing parts to isolate malfunctions, anticipate failures, and to ensure that proper repairs have been made.

#### NOTE

See tables 2-8 and 2-9 for a listing of STE/ICE tests and their related page numbers.

b. STE/ICE is used primarily with the vehicle electrical system. These tests cannot cover all possible malfunctions which may occur. If a particular malfunction is not covered, refer to Troubleshooting Index (chapter 2) and locate troubleshooting procedure for malfunction observed. To obtain maximum number of observed symptoms of the malfunction, question the operator.

### 2-17. STE/ICE CHAIN INDEX

Preventive Maintenance Checks and Services (table 2-1) contain a list of various malfunctions which may occur during operation or inspection of vehicle. When one of the malfunctions listed occurs, the mechanic proceeds to the associated STE/ICE Chain Index (tables 2-8 and 2-9).

### 2-18. VEHICLE TEST METER (VTM) TROUBLESHOOTING

The vehicle meter (VTM) troubleshooting procedures can be found in STE/ICE Go-Chain Tests (table 2-10). Additional VTM troubleshooting can be found in TM 9-4910-571-12&P, Simplified Test Equipment for Internal Combustion Engines.

### 2-19. STE/ICE TESTS AND SETUP PROCEDURES

**a. STE/ICE Tests.** The STE/ICE testing capabilities that may be applied to the M44A2 PMCS are listed in table 2-9 and are included in table 2-11. Test capabilities that may be applied to troubleshooting are specified in table 2-8.

**b. STE/ICE Setup Procedure.** STE/ICE setup and internal checks (test no. G01, table 2-10) must be performed prior to performing tests.

### 2-20. STE/ICE DESCRIPTION AND OPERATION

**a. General.** The following describes operation of Simplified Test Equipment/Internal Combustion Engines (STE/ICE) system and contains detailed operating procedures.

It is used to test serviceability of 2-1/2-ton vehicles and to perform primary fault detection and isolation. After technician has identified a faulty part or subsystem, he is referred to a paragraph number for replacement or repair procedures for individual parts.

**2-20. STE/ICE DESCRIPTION AND OPERATION (Contd)**

**b. Description and Operation.** STE/ICE is a testing system that performs tests and measurements on internal combustion engines. STE/ICE measures standard voltage, current, resistance, pressure, temperature, and speed measurements. Special tests, such as compression balance tests and starter system evaluations, are performed by STE/ICE. Standard equipment functions including vacuum pressure gage, compression gage, low-current tester, and multimeter are features of STE/ICE set.

STE/ICE is portable and operates on either 12- or 24-volt vehicle batteries or equivalent power source. The STE/ICE system consists of a Vehicle Test Meter (VTM), a Transducer Kit (TK), six electrical cables, a transit case, test cards, and technical publications.

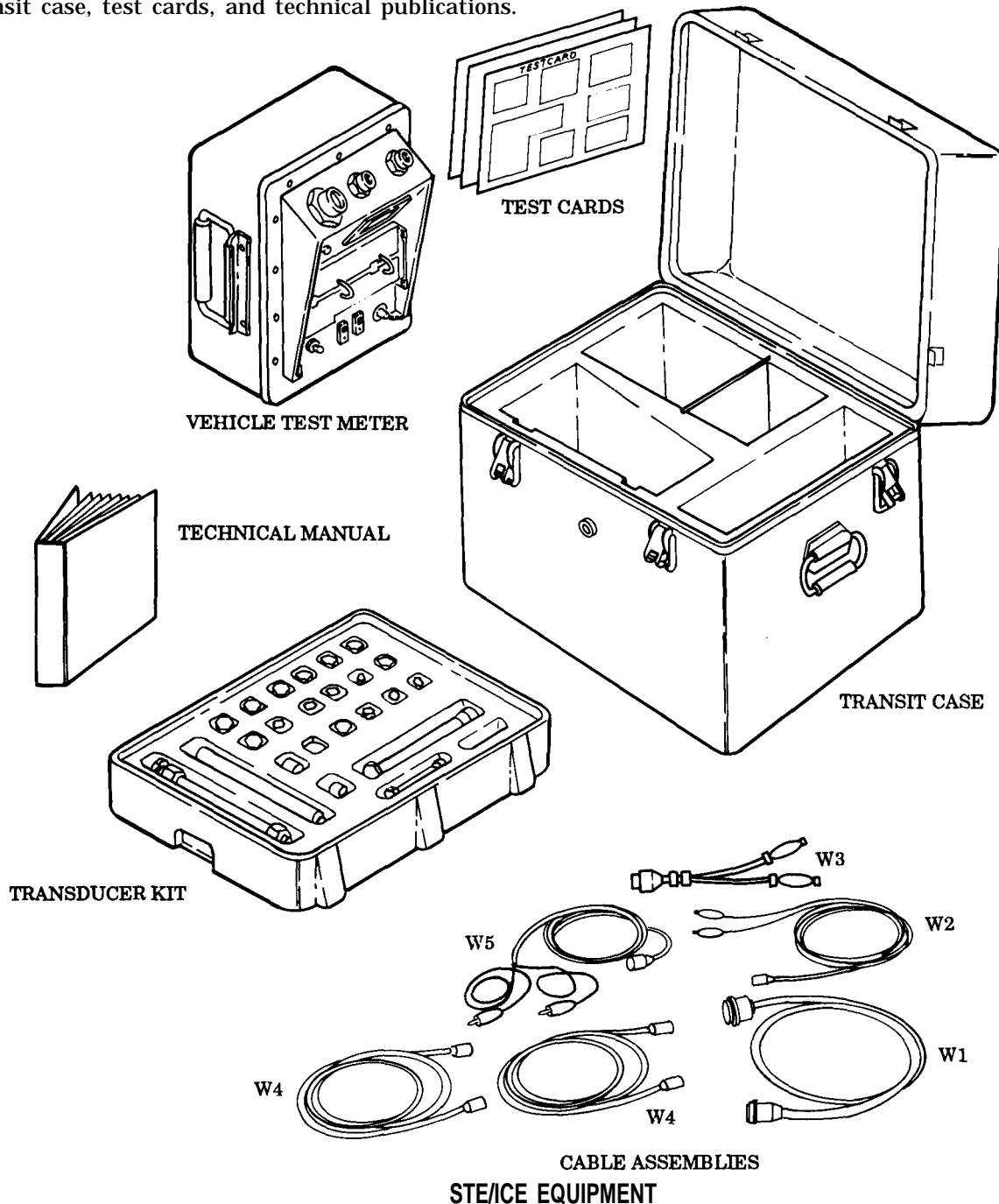

## 2-20. STE/ICE DESCRIPTION AND OPERATION (Contd)

### c. Vehicle Test Meter.

**(1) General.** The VTM provides a method for technician to test vehicle electrical and mechanical components. Readings are either pass/fail indications or digital displays in units familiar to technician (psi, rpm, volts, ohms, amps, etc.). The VTM interfaces with vehicle directly with a transducer(s) from Transducer Kit (TK). Additional tests can also be done that involve manually probing and/or connecting transducers to appropriate test points. Operating power for VTM is drawn from vehicle batteries or some equivalent power source. Power is routed to VTM through cable clamps connected to battery. The STE/ICE general purpose testing capabilities that may be applied to vehicle are: 0-1000 psig pressure, 0-45 volts DC, and 0-40k ohms resistance. The following control functions can be performed in conjunction with special tests: interleave (displays rpm with next test), display maximum value, display minimum value, and display peak-to-peak value.

**(2) Controls and Indicators.** The controls and readout display on VTM are illustrated. The following paragraphs describe how the controls are used, and how displays function.

**(a) Power Switch (PUSH ON/PULL OFF).** The power switch controls DC power to VTM. The VTM can operate from either a 12-volt or 24-volt battery system. When power switch is pushed in (PUSH ON), VTM power is on. To shut VTM off, pull out power switch (PULL OFF). The power switch contains a 4-amp circuit breaker. If a fault occurs and VTM uses more power than it should, power switch will pop out automatically. Check your hookup carefully and try again before returning VTM to support maintenance.

**(b) TEST SELECT Switches.** The TEST SELECT switches are used to select actual test to be performed. There are ten positions on each switch, numbered 0 through 9. The number dialed into these switches is read by VTM when you press TEST button. Changing TEST SELECT switch positions has no effect until TEST button is pushed on.

**(c) TEST Button.** Depressing and releasing TEST button causes test measurement to begin. Observe measured value on readout display. The reading will be in units normally used for a particular vehicle measurement. These units are listed on the flip cards. The TEST button must be pressed and immediately released. Depressing and holding TEST button down initiates an offset test. Offset tests are described in TM 9-4910-571-12&P.

**(d) Readout Display.** The readout display will show different types of readouts during testing up to a maximum of 4 characters (for example .8.8.8.8). Types of readouts are described in detail in paragraph (3) and are summarized as follows:

**1. Status Readout.** This type of readout keeps technician informed of what is happening such as power applied, failed test, etc.

**2. Numerical Readout.** This type of readout is the measured value in units of the measurement being made. If you are measuring 0-45 volts DC, the number 24 on display indicates 24 volts.

**3. Error Readout.** This type of readout indicates that wrong test number was selected, transducer is not connected, or VTM is faulty.

**(e) Flip Cards.** The flip cards list the 2-digit test number system for selecting various tests. The cards also summarize test and operating instructions contained herein.

**(f) Transducer Cable Connector J4.** Connectors J2 and J3 connect VTM to any transducer in transducer kit. Operating power is supplied to transducer, and signals from transducers are supplied to VTM through the cable. Connectors J2 and J3 are identical and can be interchanged with each other or used in combination.

**(g) Test Probe Cable Connector J4.** Connector J4 connects test leads to VTM when doing manual voltage and resistance tests.

**2-20. STE/ICE DESCRIPTION AND OPERATION (Contd)**

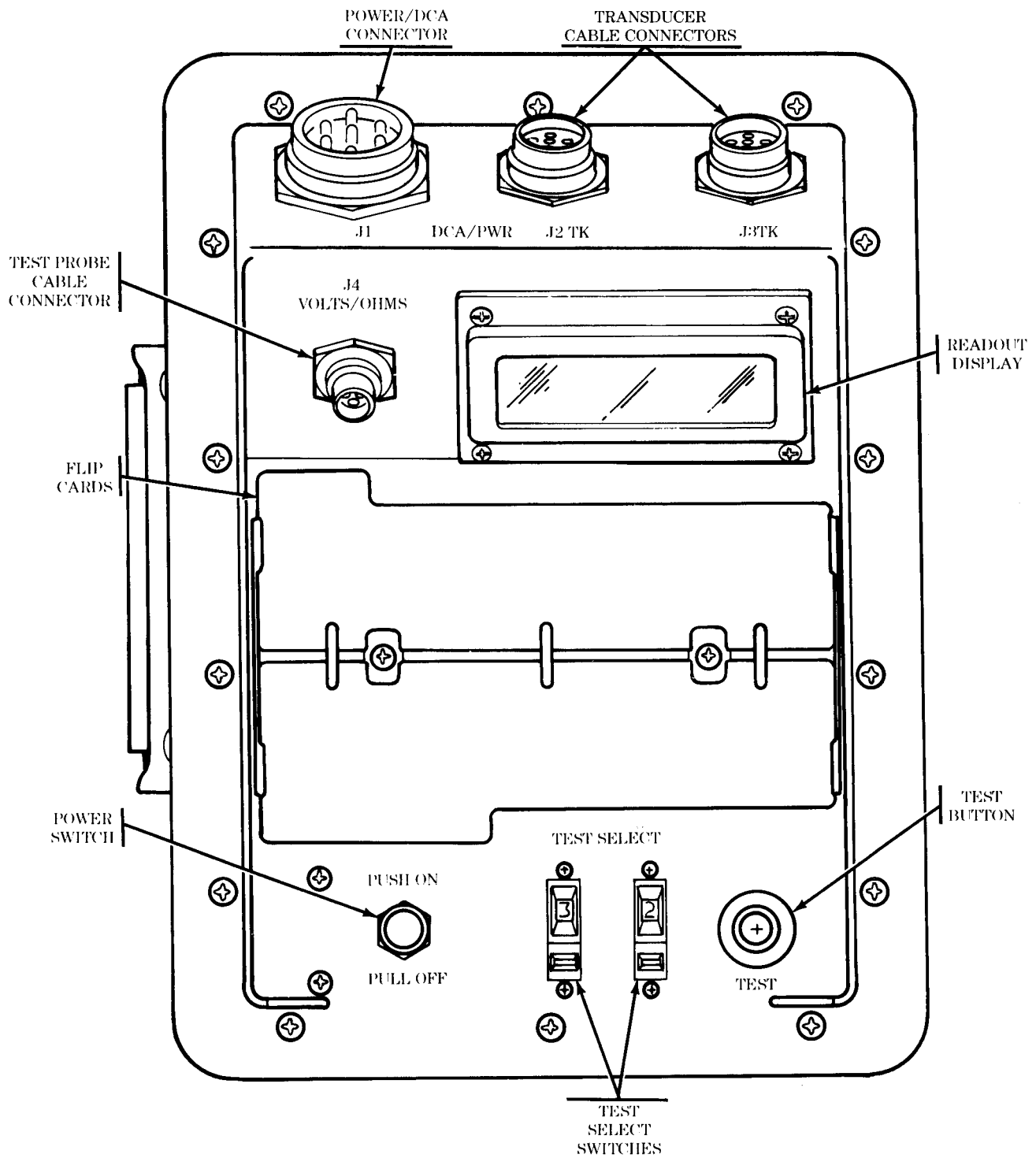

**VTM CONTROLS AND READOUT DISPLAY**

**2-20. STE/ICE DESCRIPTION AND OPERATION (Contd)**

**(3) Readouts.** The following paragraphs describe different types of readouts that can occur during testing.

**(a) Status Readout.** A status readout keeps technician informed of what is happening. For example, .8.8.8.8 is displayed each time the power switch is pushed on. It means that power is applied, and that all elements of the display are operative. It changes to four dashes 1.5 seconds later, indicating that the VTM is ready to be used for testing. The status readout displays are described in table 2-5.

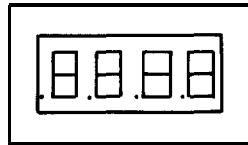

**(b) Prompting Message.** A prompting message is a technician action message. It is a signal for you to do something such as crank engine. For example, UEH tells you to enter the vehicle identification number into VTM. After technical action is performed, test will automatically continue. Prompting messages are listed in table 2-6.

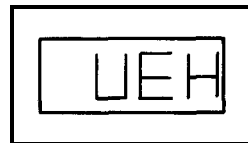

**(c) Numerical Readout.** A numerical readout is the measured value in units of measurement being made. For example, if you are measuring 0-45 volts DC, 12.7 is volts DC. If you are measuring 0-25 psig pressure, 12.7 is psig. Units for each test are listed on the flip card.

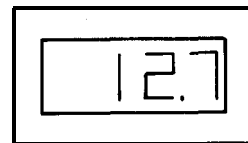

**(d) Error Readout.** E001 is a typical error readout. There are 17 different error readouts. All error readouts start with E. An error readout is a warning that you forgot to connect the transducer, selected a wrong test number, failed to start engine, etc. All error messages mean you must correct problem before continuing testing. Error messages are described in table 2-7. If an error message does not go away after corrective action, refer to TM 9-4910-571-12&P.

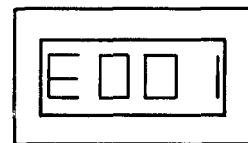

**(e) Confidence Error Readouts.** C004 is a typical error readout resulting from detection of a fault VTM during confidence test.

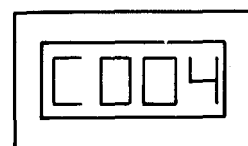

<b>2-20. STE/ICE DESCRIPTION AND OPERATION (Contd)</b>
--

Table 2-5. Status Readouts.

VTM Readout	Interpretation
.8.8.8.8	<p>A readout of .8.8.8.8 appears for 1 to 2 seconds each time power is applied to VTM. It means that there is power to the VTM, and all elements of readout display are operative.</p> <p>A readout of four dashes indicates the following</p> <ol style="list-style-type: none"> <li>(1) After power is turned on, it signifies that VTM is ready for testing.</li> <li>(2) During a compression unbalance test, it signifies testing is in progress.</li> <li>(3) During battery condition test, it signifies battery may be in discharged state.</li> </ol>
.9.9.9.9	A readout of .9.9.9.9 indicates that VTM is reading a test value beyond the range of its measurement capability. Either (1) the wrong test number is selected for parameter being measured; (2) there is fault in vehicle; or (3) during battery condition test, it signifies bad connections, discharged, or bad batteries.
PASS FAIL	PASS or FAIL readout is the result of a test that checks the condition of a component being measured. A PASS/FAIL readout means component either passes the test or fails the test.

Table 2-6. Prompting Messages.

VTM Readout	Interpretation
UEH	Signal to technician to enter vehicle identification number (VID) on TEST SELECT switches. Vehicle ID numbers are found under TEST DATA on flip cards, on vehicle test card, and in appendix.
GO	Signal to technician to crank engine in compression balance or first peak tests. During battery condition test, indicates a weak battery in series pair of batteries being tested.
CIP	Signal to technician to apply full throttle in a C1 power test.
OFF	Signal to technician to stop cranking in compression balance test.
CAL	Signal to technician to release the TEST button during an offset test.
66	Numbers are used for prompting messages in several tests. They are as follows: in confidence, test 66 signals the technician to dial in "99", in CI acceleration/deceleration power test No. 12, the first numerical readout signals the technician to shut off fuel.

**2-20. STE/ICE DESCRIPTION AND OPERATION (Contd)**

*Table 2-7. Error Readouts.*

VTM Readout	Interpretation
E000	Occurs if you request VTM for information it does not have. For example, if you request vehicle ID and it has not yet been entered.
E001	Indicates that a non-existent test number has been dialed into TEST SELECT switches.
E002	Indicates that required transducer is not connected.
E004	Indicates that a vehicle identification number or number of cylinders information has not been entered.
E005	Indicates that transducer offset test was not performed.
E007*	Indicates a conflict between vehicle identification number (VID) dialed in and the number of cylinders dialed in. It may occur in response to either VID entry or number-of-cylinders entry.
E008	Indicates VTM is not receiving required voltage signal for test selected. This error code is related only to starter and compression balance tests.
E009	Indicates that engine is not running at start of test.
E010*	Indicates that wrong vehicle identification number has been entered.
E011	Indicates that throttle control was operated incorrectly during power test, taking too much time to either accelerate or decelerate.
E012	Indicates that CI pulse tachometer is missing.
E013	Indicates bad data were taken for test in progress. Repeat test one (1) time.
E014*	Indicates that a wrong number of cylinders was dialed into VTM.
E015*	Indicates that number of cylinders dialed into VTM in DCA mode conflicts with number of cylinders in vehicle. Applies to SI vehicles only.
E017	Indicates that engine is not running, or that ignition adapter is broken or not properly connected.
E018	Indicates that an engine rpm or AC frequency test was terminated automatically to protect VTM. Termination is only after several minutes of no-signal operation. Most likely VTM was left on vehicle and engine stalled.

\* Different STE/ICE vehicle connectors have different DCA numbers. This error message has a special meaning if you are connected to DCA number 13 and message is displayed in response to a CYL or UEH entry. In these cases, you may continue testing, but message is a warning that tests using CYL and UEH information are normally performed with VTM connected to a different connector in the vehicle. A different connector will have a different DCA number. You can find out what DCA number you are connected to by entering test 62.

## 2-20. STE/ICE DESCRIPTION AND OPERATION (Contd)

### d. Cable Assemblies.

(1) **General.** Cable assemblies are referred to by cable number and by a name which describes how cable is used. If necessary, two transducer cables (W4) can be joined with adapter supplied in the transducer kit to make one long cable.

(2) **Installation.** When cables are connected, the large key on cable connector mates with a keyway on transducer connector or VTM connector for proper installation. If you experience any difficulty during testing and suspect that a cable is bad, refer to TM 9-4910-571-12&P for checking cable continuity.

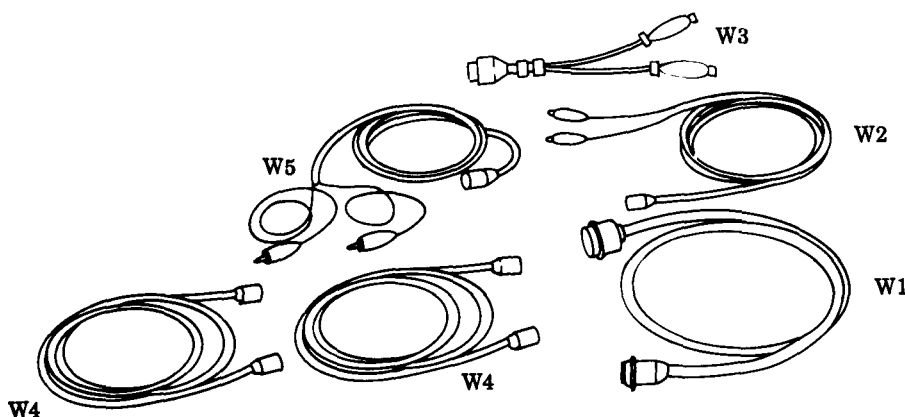

CABLE ASSEMBLIES

### e. Transducer Kit (TK).

(1) **General.** The transducer kit contains a pulse tachometer transducer, a pressure and vacuum transducer, and necessary adapters (bushing, plugs, tees, etc.). Also included in transducer kit is a current probe for measuring current and a test probe cable for measuring voltage and resistance.

All fittings do not have part number markings. The legend will help to identify items.

Before installing any transducer kit item on vehicle, be sure to clean the mounting surfaces. This is particularly important if you are going to open fuel lines or tap into manifolds. Dirt particles entering engine can cause damage to both engine and transducer kit item.

The transducers should be kept clean, free of dirt and grease, and handled with reasonable care.



**2-20. STE/ICE DESCRIPTION AND OPERATION (Contd)**

**(2) Pressure Transducers.** The pressure transducers have a small breather hole on the side of the housing which should be kept unplugged. Do not use high pressure shop air to clean transducers.

**(3) Pulse Tachometer.** Ensure that slotted hole in engine tachometer drive shaft is clear and not hard packed with lubricant before installing pulse tachometer.

**(4) Threaded Adapters.** Observe threaded fittings carefully to avoid engaging straight threads with pipe threads.

Each measuring device (transducer) in transducer kit has its own identification resistor. The VTM uses this identification resistor to check that correct transducer is connected for measurement being made. If the correct transducer is not connected, error code E002 will be displayed.

**2-21. VEHICLE TESTING**

**a. General.** To troubleshoot a vehicle problem, the technician can use STE/ICE (vehicle test meter and transducers) and vehicle test card.

**b. Offset Tests.** STE/ICE VTM performs a test by setting TEST SELECT switches to test number and pressing TEST button. For some tests, an offset test is required before test itself can be performed. This is done by selecting number of desired test and holding TEST button down for several seconds.

The offset test voids characteristic differences in VTM, test leads, and transducers. It “zeros” meter. Once offset is performed, VTM automatically corrects for offset before displaying measured values. Displayed offset value should be checked against limits on vehicle test card. If displayed value is outside these limits, either transducer or test cable is faulty and must be replaced. This is another form of self-test. The offset is performed when each transducer is connected. All tests requiring offset are identified by an asterisk (\*) on flip cards and by OFFSET LIMITS on vehicle test cards. The offset test is performed with test probe cable or transducer connected to VTM. Care should be taken to see that no stimulus is applied to transducer. Test probe cable leads should be shorted together. To perform an offset test, dial test number into TEST SELECT switches. Press and hold TEST button until prompting message CAL appears on display. In a few seconds after release of TEST button, a number will appear. This is a measured offset value associated with test probe cable or transducer and cable.

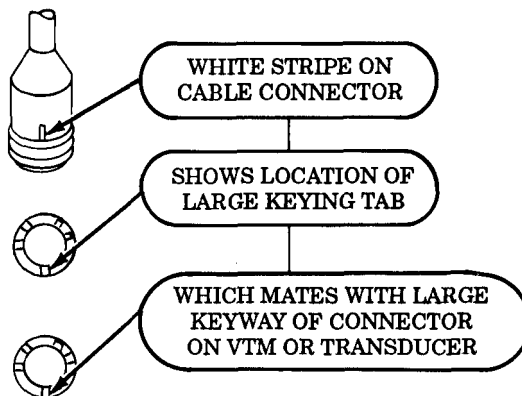

**CONNECTOR KEY LOCATION**

**2-21. VEHICLE TESTING (Contd)**

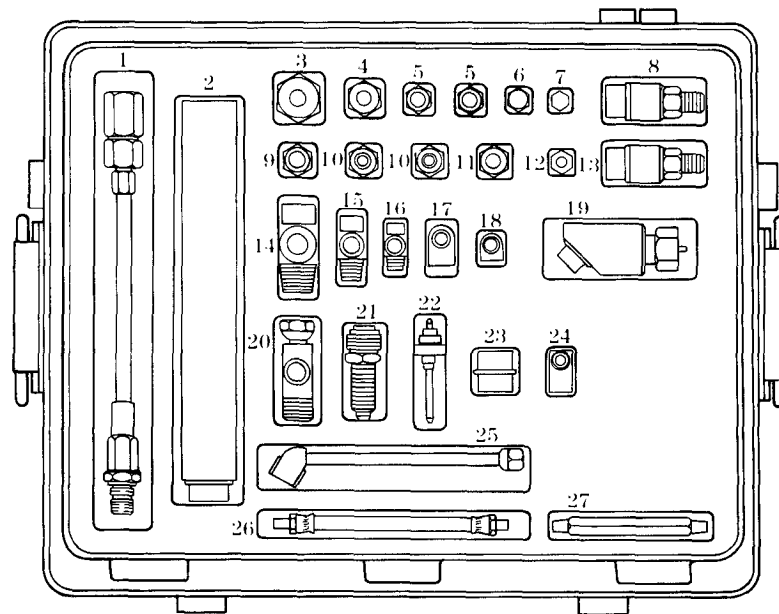

*Transducer Kit.*

ITEM NO.	TK NO.	PART NO.	QTY	ITEM
1	10	11669227	1	Hose and fitting assy (spark plug adapter)
2	11	12258878	1	Current probe
3	12	12258853-1	1	Pipe thread reducer, 3/4 MPT to 1/4 FPT
4	13	12258853-3	1	Pipe thread reducer, 1/2 MPT to 1/4 FPT
5	14	12258853-2	2	Pipe thread reducer, 3/8 MPT to 1/4 FPT
6	15	444620	1	Hex head plug, 1/4 MPT
7	16	5327970	1	Hex head plug, 1/8 MPT
8	17	12258876	1	Pressure transducer, 0-1000 psig
9	21	12258881	1	Snubber
10	20	3204X2	2	Adapter, 1/8 MPT to 1/4 FPT
11	19	3304Y2	1	Coupling reducer, 1/8 FPT to 1/4 FPT
12	18	234X5	1	Male connector, 5/16 tube to 1/4 MPT
13	22	12258877	1	Pressure transducer, -30 in. Hg to 25 psig
14	23	444152	1	Street tee, 1/2 pipe thread
15	24	3750X4	1	Street tee, 1/4 pipe thread
16	25	547002	1	Street tee, 1/8 pipe thread
17	26	12258879-2	1	Street elbow, 1/4 pipe thread
18	27	12258879-1	1	Street elbow, 1/8 pipe thread
19	34	12258875	1	Pulse tachometer
20	32	12258880	1	Fuel line adapter
21	31	MS53099-2	1	Tachometer drive adapter
22	30	7540877	1	Ignition adapter
23	29	MS3119E14-19	1	Adapter (connector-to-connector)
24	28	12258762	1	Tee, inverted flare
25	33	8840543	1	Air chuck
26	35	11669236	1	Hose assembly, 1/8 MPT
27	36	12258852	1	Pipe nipple, 1/8 MPT

**2-21. VEHICLE TESTING (Contd)**

**c. Control Tests.** These tests are used to change (or control) the way a vehicle test is displayed, or the way it is run. There are five (5) control tests:

- 01 Interleave (displays RPM with next test).
- 02 Display minimum value for next test.
- 03 Display maximum value for next test.
- 04 Display peak-to-peak value for next test.
- 05 Initiate full power simulation.

Control tests 01, 02, 03, and 04 specify action to be taken by the next test only.  
A subsequent test will reset the control.

**(1) Interleave (Test 01).** This test alternately measures engine speed and a second parameter such as fuel pressure or alternator voltage. To initiate interleave, dial 01 into TEST SELECT switches and press and release TEST button. The prompting message PASS will signal the technician to dial in second test number and again press and release TEST button.

**(2) Minimum Value (Test 02).** This test displays minimum value measured during a test. To initiate a minimum value display, dial 02 into TEST SELECT switches and press and release TEST button. The prompting message PASS will signal technician to dial in desired test number and again press and release TEST button. The minimum value is displayed and updated whenever a lower minimum value is measured. Entering 02 and test number again will reset process and a new minimum value will be displayed.

**(3) Maximum Value (Test 03).** This test displays maximum value measured during a test. To initiate a maximum value display, dial 03 into TEST SELECT switches and press and release TEST button. The prompting message PASS will signal technician to dial in desired test number and again press and release TEST button. The maximum value is displayed and updated whenever a higher maximum value is measured. Entering 03 and test number again will reset process and new maximum value will be displayed.

**(4) Peak-to-Peak Value (Test 04).** This test displays peak-to-peak value of dwell (test 16), alt/gen output volts (test 82), 45-volts DC (test 89), 1500 amps DC (test 90), and battery volts (test 67). Electrical peak-to-peak is for measuring dwell variation. To start peak-to-peak measurement, dial 04 into TEST SELECT switches and press TEST button. The prompting message PASS will signal operator to dial in one of five test numbers (16, 82, 89, 90, 67) and again press TEST button.

**(5) Full Power Simulation (Test 05).** This test lets you test SI engines under full power operating conditions. Test 05 differs from the previous four control tests in several ways. First, it must be preceded by a number-of-cylinders entry (test 58) or VID entry (test 60). After number of cylinders or VID has been entered, and engine is warm and idling, 05 is dialed into TEST SELECT switches, and TEST button is pressed. The prompting message SIP will signal operator to press accelerator to floor. The VTM will monitor engine speed during acceleration, and at approximately 3500 rpm, VTM will begin full power simulation. Simulation will continue until operator releases accelerator. PASS message is displayed when simulation starts. A measurement can now be made during power simulation by dialing desired test number and pressing TEST button. New test and control functions can be selected until accelerator is released. The 05 control feature provides a more accurate indication of engine performance than does testing under unloaded conditions.

**2-21. VEHICLE TESTING (Contd)***Table 2-8. CI Engine Go-Chain Index, TK Mode.*

<b>GO. TEST NUMBER</b>	<b>TEST TITLE</b>	<b>PAGE NUMBER</b>	<b>TABLE NUMBER</b>
G01	VTM Connections and Checkout	2-160	2-10
G02	First Peak Test	2-165	2-10
G03	Pulse Tachometer Installation	2-167	2-10
G04	Engine Start - Lubrication Check	2-168	2-10
G05	Charging Circuit and Battery Voltage Test	2-171	2-10
G06	Engine Warmup/Coolant Check/Oil Pressure Test	2-173	2-10
G07	Governor Check/Power Test	2-175	2-10
G08	Idle Speed/Governor Check	2-177	2-10
G09	Compression Unbalance Test	2-178	2-10

*Table 2-9. CI Engine No-Go Chain Index, TK Mode.*

<b>NO-GO. TEST NUMBER</b>	<b>TEST TITLE</b>	<b>PAGE NUMBER</b>	<b>TABLE NUMBER</b>
NG05	Low Oil Pressure Check	2-180	2-11
NG20	No Crank - No Start	2-182	2-11
NG30	Engine Crank - No Start	2-183	2-11
NG31	Gage Test	2-188	2-11
NG50	Charging Circuit Tests	2-190	2-11
NG80	Starter Circuit Tests	2-199	2-11
NG81	Battery Tests	2-205	2-11
NG90	Governor/Power Test Fault Isolation	2-209	2-11
NG120	Battery Compartment - Positive Side Voltage Drop Checks	2-215	2-11
NG121	Battery Compartment - Negative Side Voltage Drop Checks	2-216	2-11
NG130	Engine Tightness Test	2-217	2-11

**NOTE**

Test G01, VTM connections and checkout, must be performed before running any other STE/ICE test.

Table 2-10. STE/ICE Go-Chain Tests

**NOTE**  
Test G01, VTM Connections and Checkout, must be performed before running any other STE/ICE test.

**G01 VTM CONNECTIONS AND CHECKOUT**

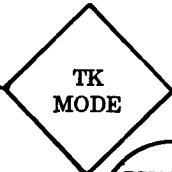

**CAUTION**  
Do not connect or disconnect VTM while vehicle engine is running.

**CAUTION**  
Connect P1 of power cable W5 to J1 on VTM before connecting clip leads to battery.

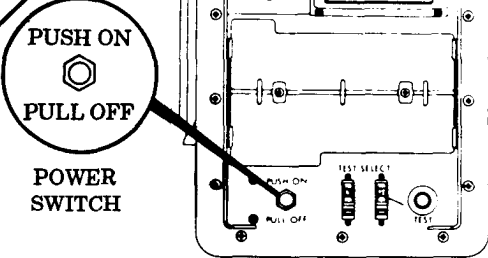
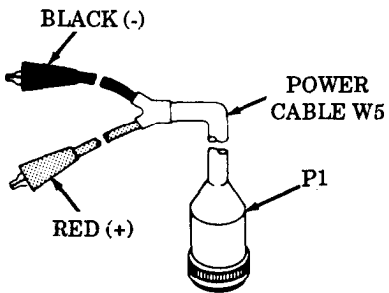

- 1 CONNECT BATTERY POWER TO VTM:**
- PULL OFF the power switch on VTM.
  - Connect P1 of power cable W5 to J1 on VTM.
  - Connect red clip lead of cable W5 to positive terminal of vehicle battery.
  - Connect black clip lead of cable W5 to negative terminal of vehicle battery.

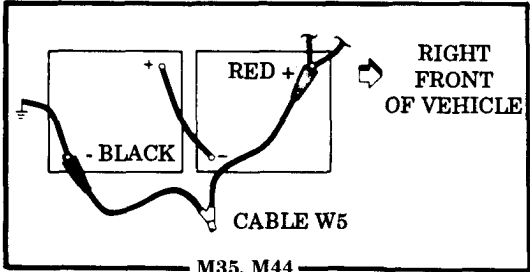

• Proceed to step 2.

- 2 POWER UP:**
- PUSH ON the power switch on VTM.
  - Verify that display indicates .8.8.8.8 for approximately 2 seconds and then changes to four dashes.
- 
- Does VTM switch display .8.8.8.8 and then change to four dashes?

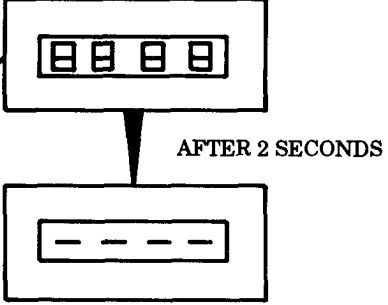

Table 2-10. STE/ICE Go-Chain Tests (Contd).

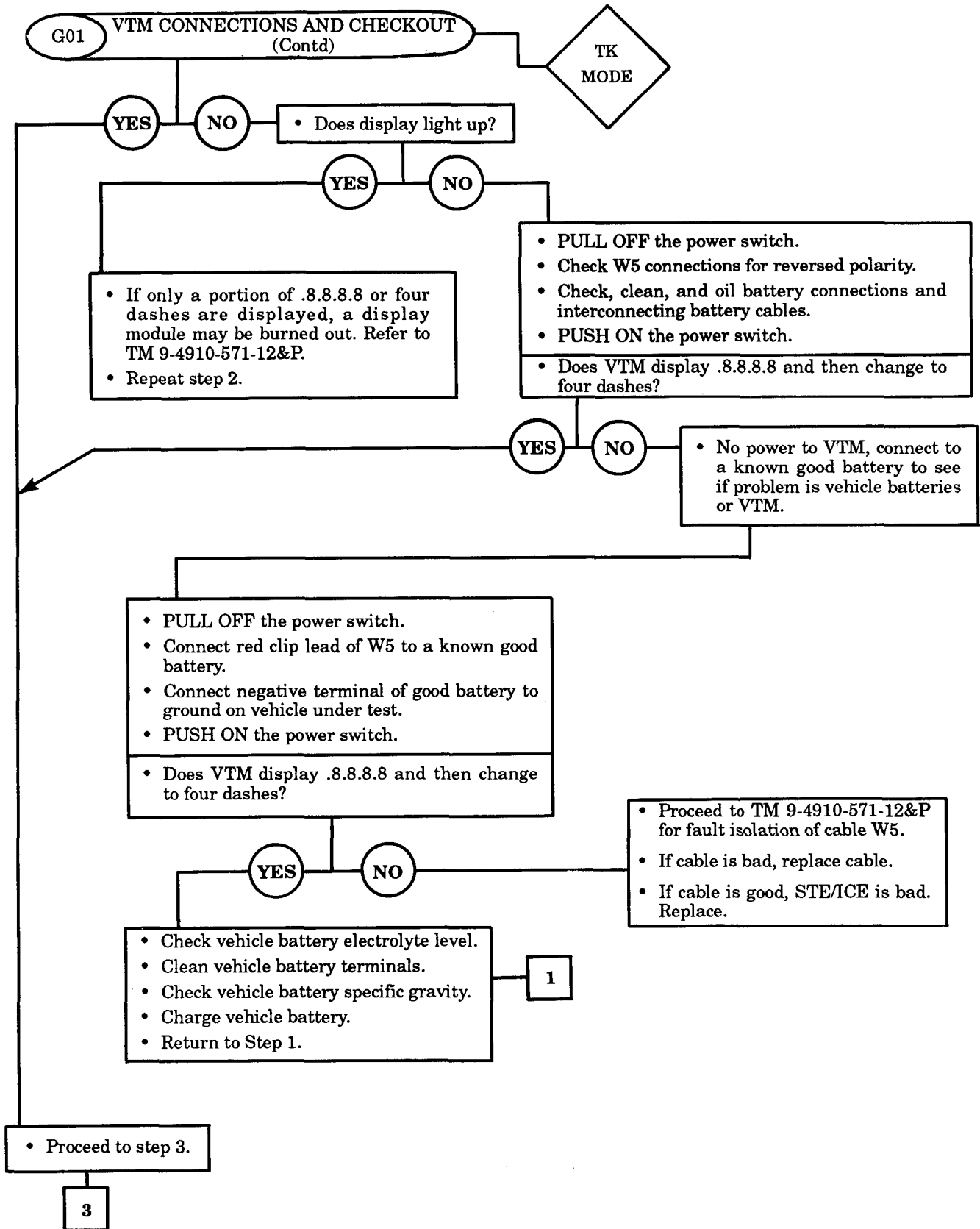

Table 2-10. STE/ICE Go-Chain Tests (Contd).

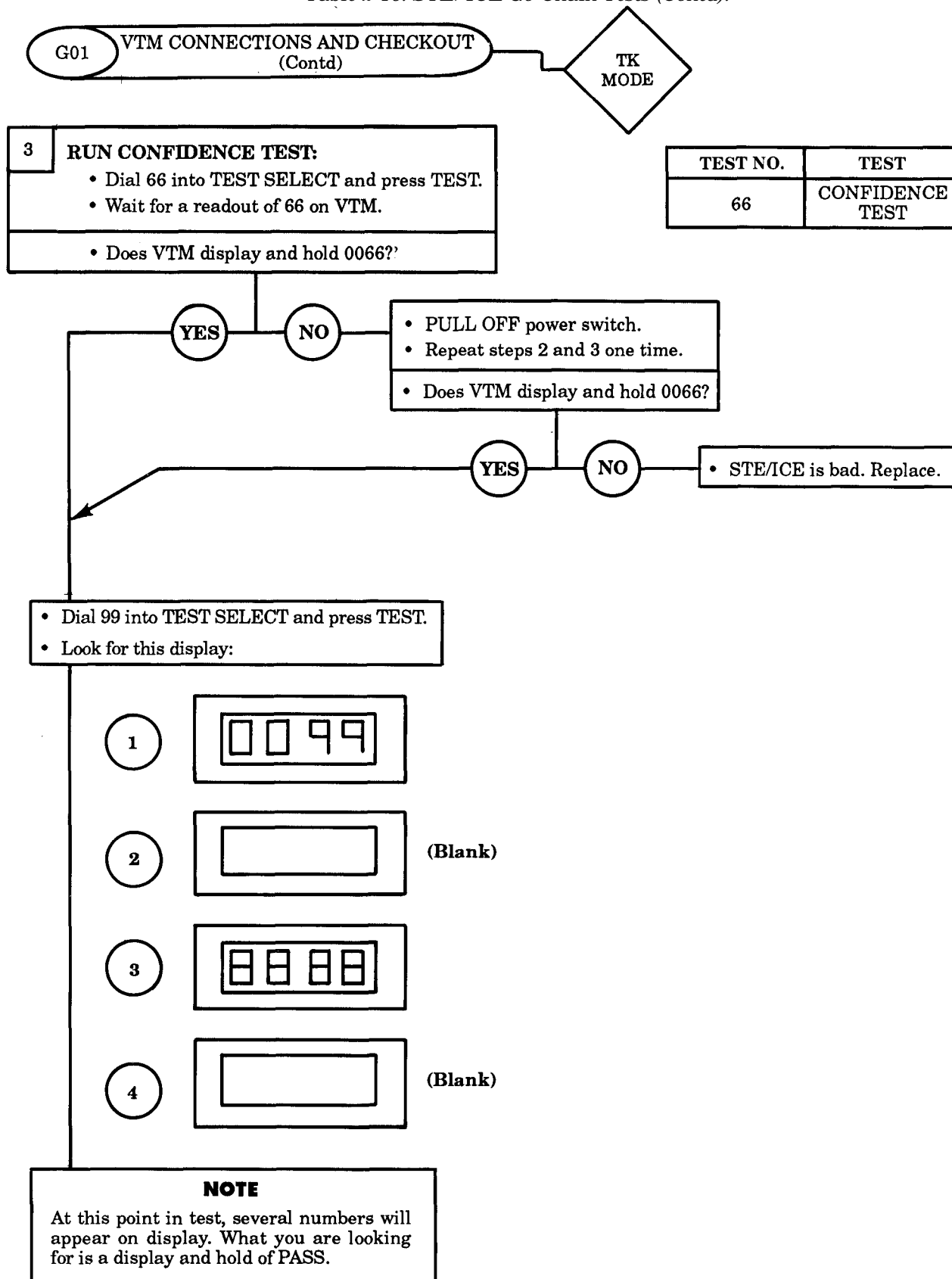

Table 2-10. STE/ICE Go-Chain Tests (Contd).

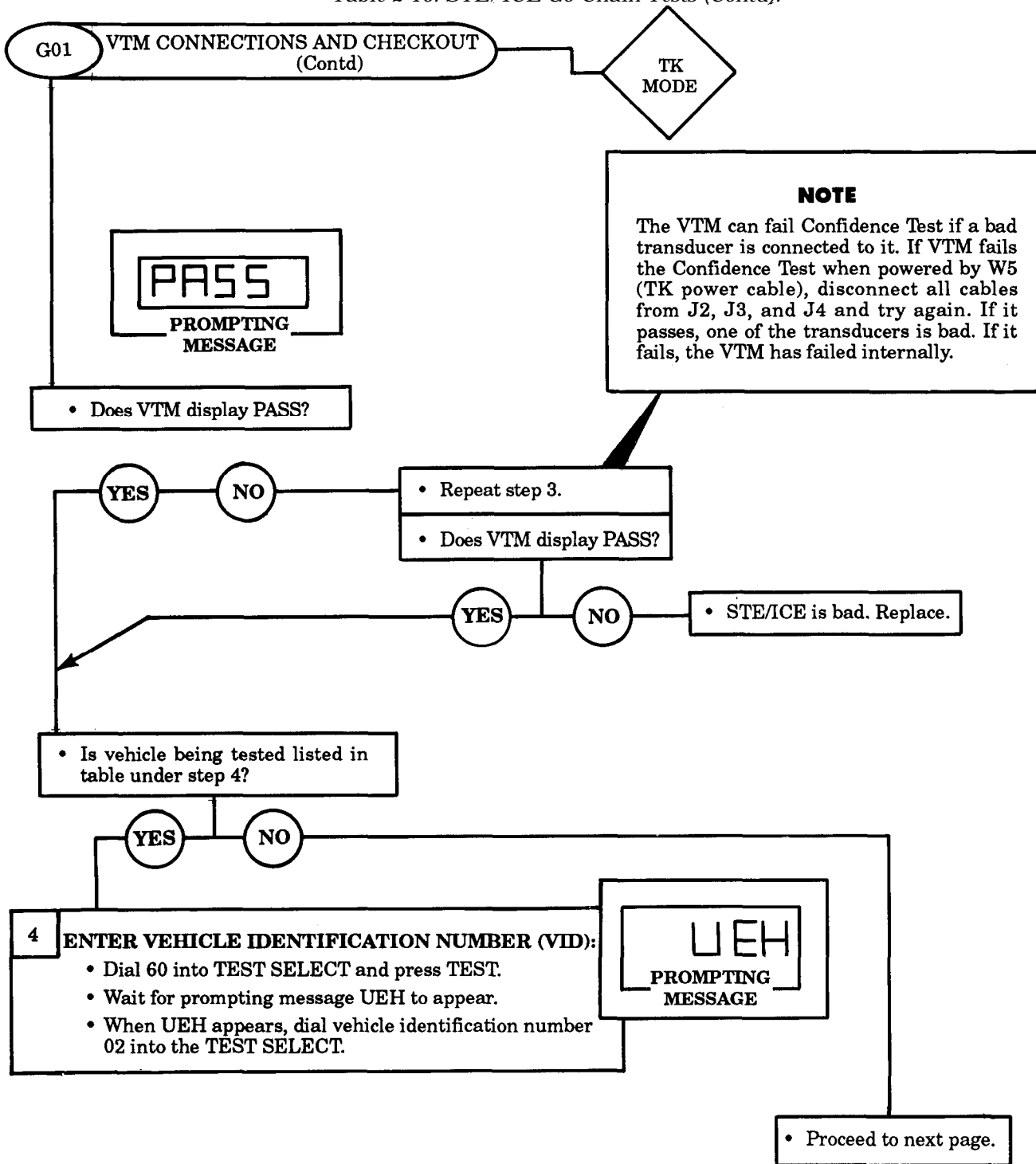



Table 2-10. STE/ICE Go-Chain Tests (Contd).

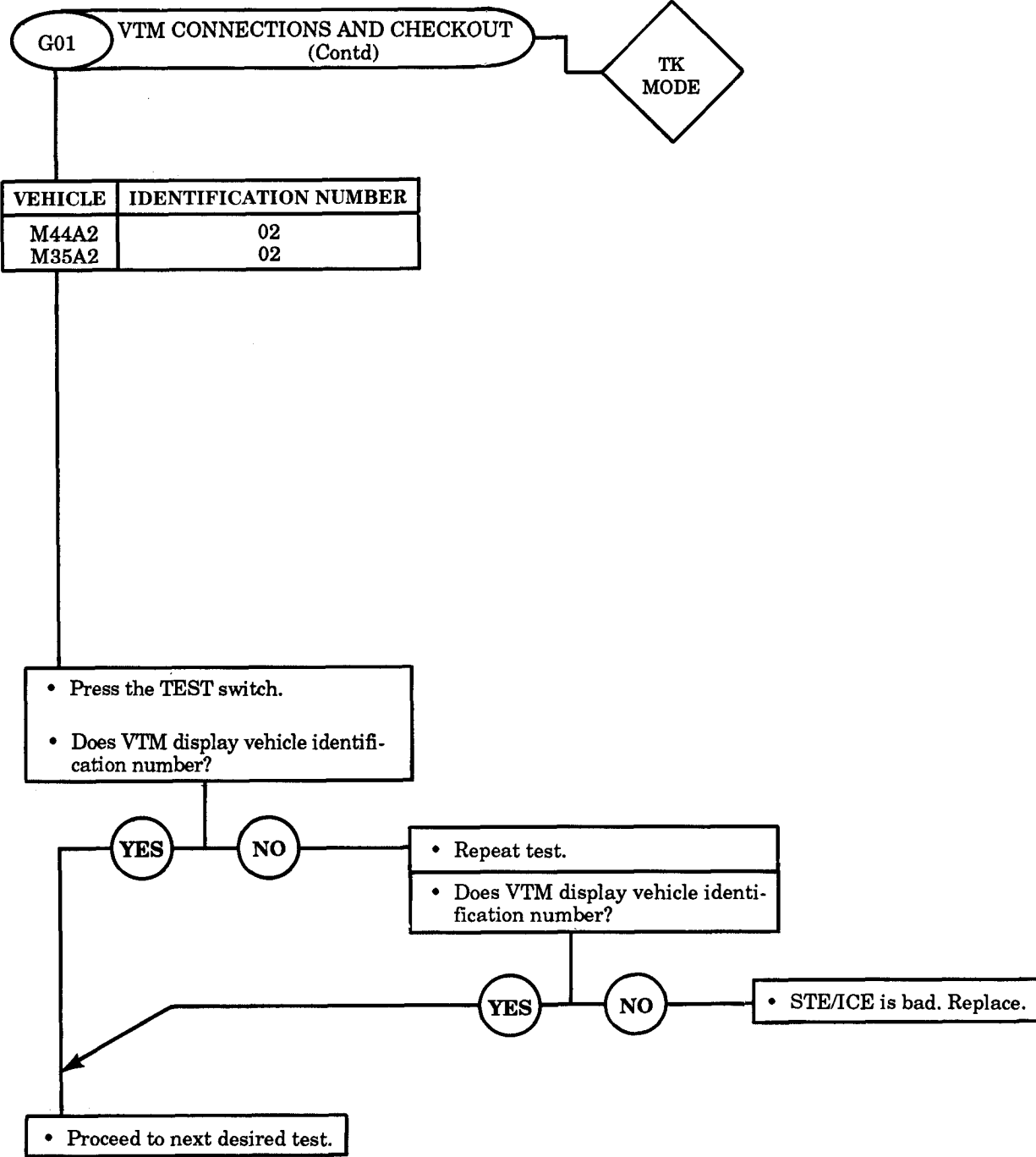

Table 2-10. STE/ICE Go-Chain Tests (Contd).

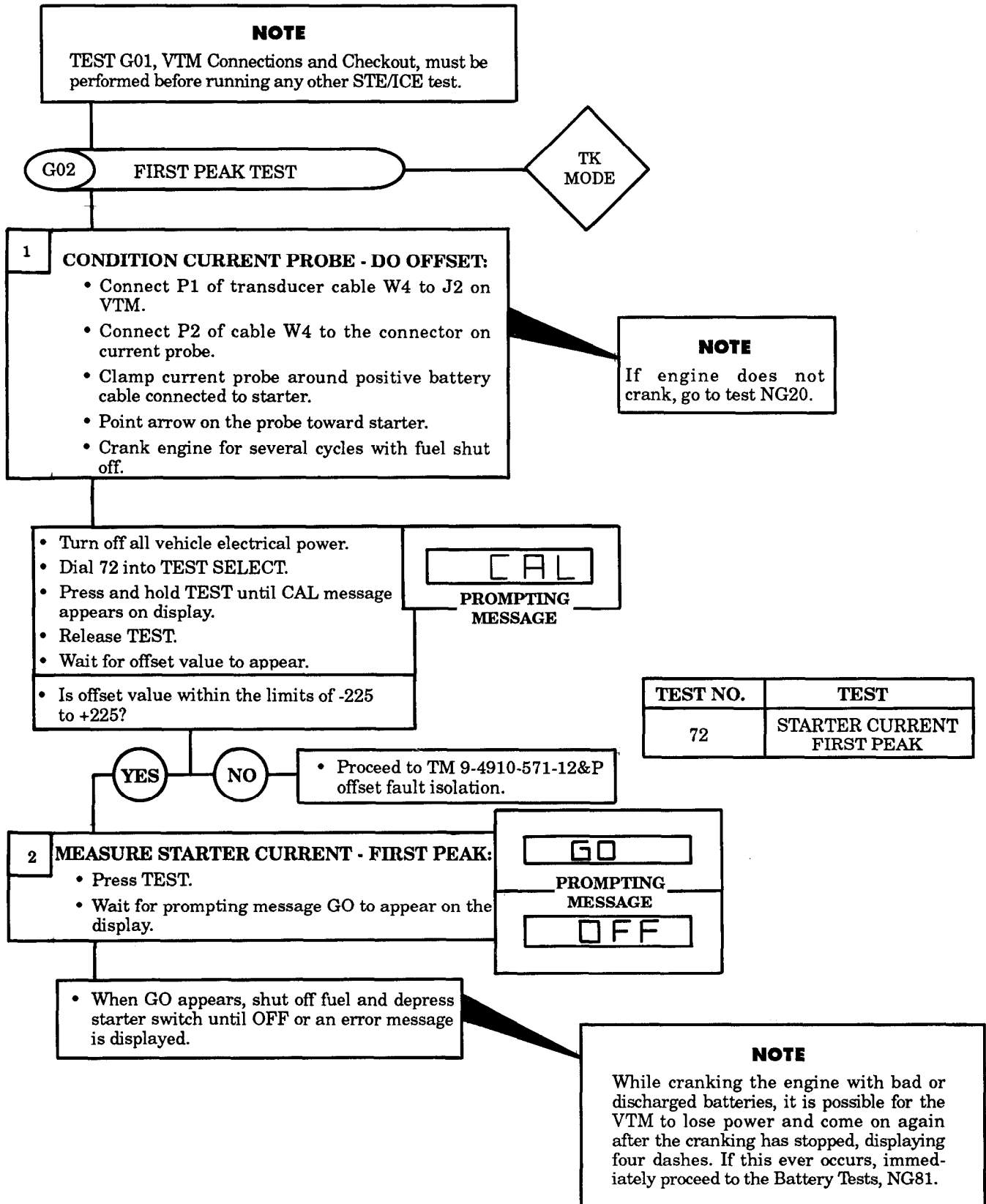

Table 2-10. STE/ICE Go-Chain Tests (Contd).

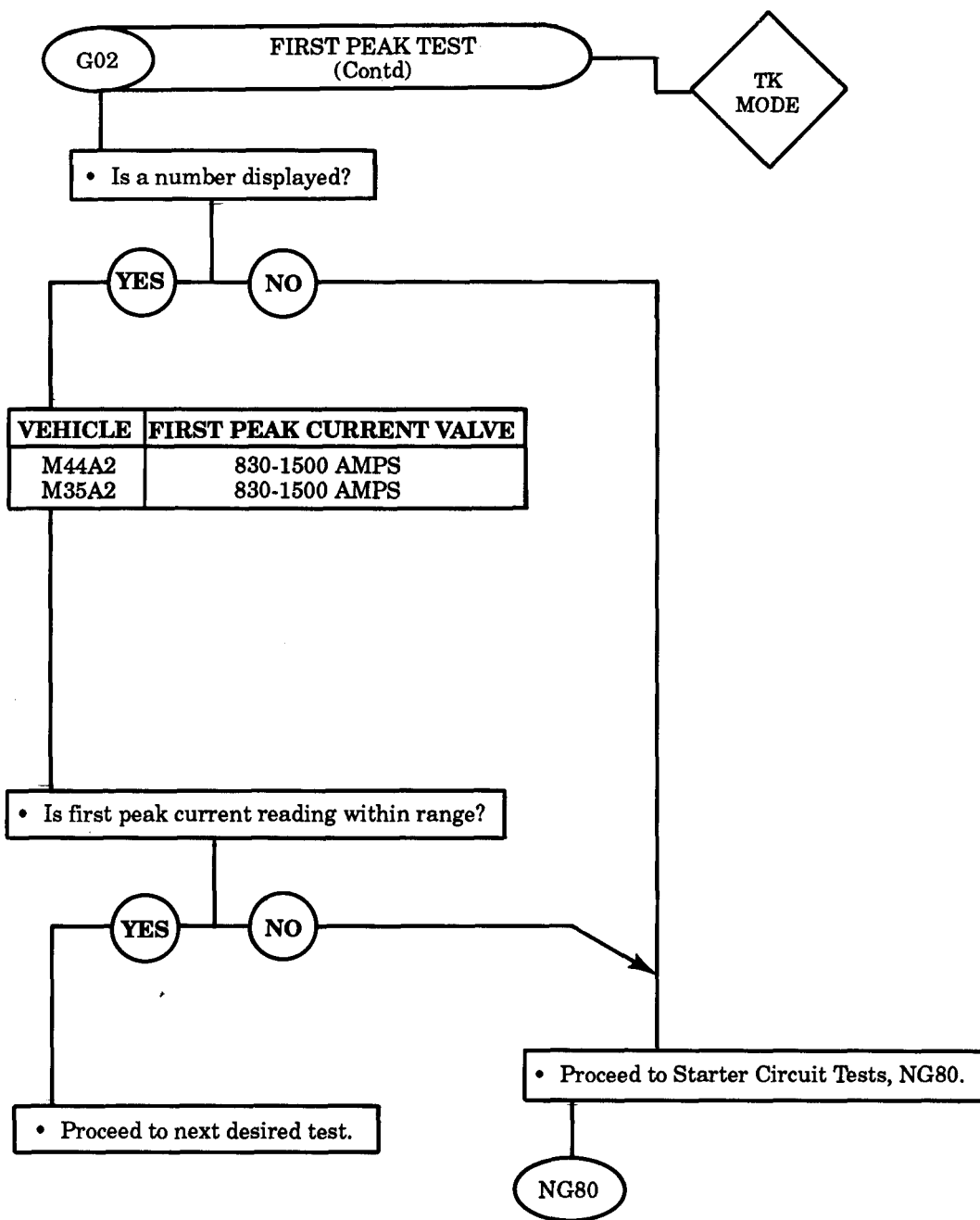

Table 2-10. STE/ ICE Go-Chain Tests (Contd).

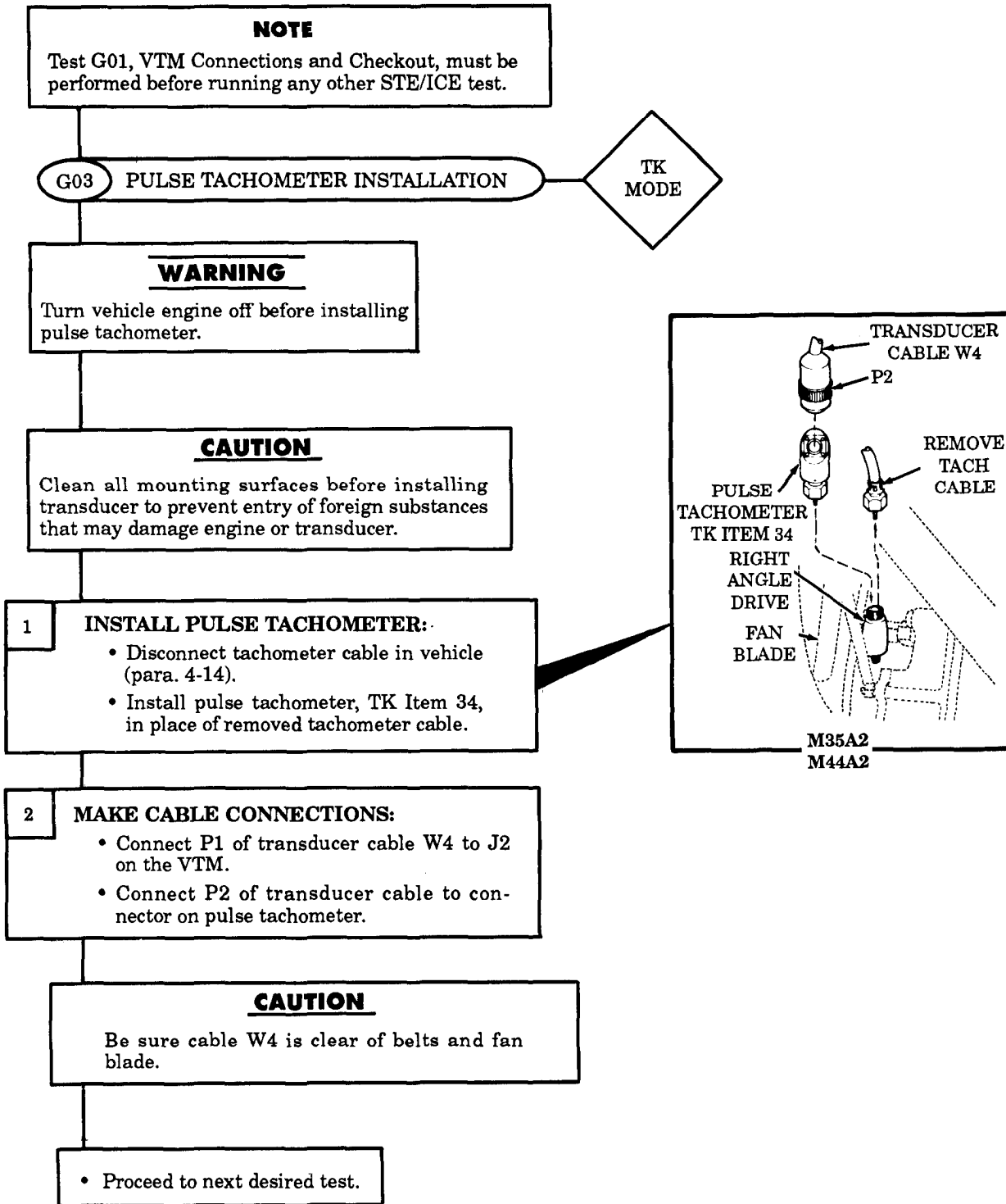

Table 2-10. STE/ICE No-Go Chain Tests (Contd).

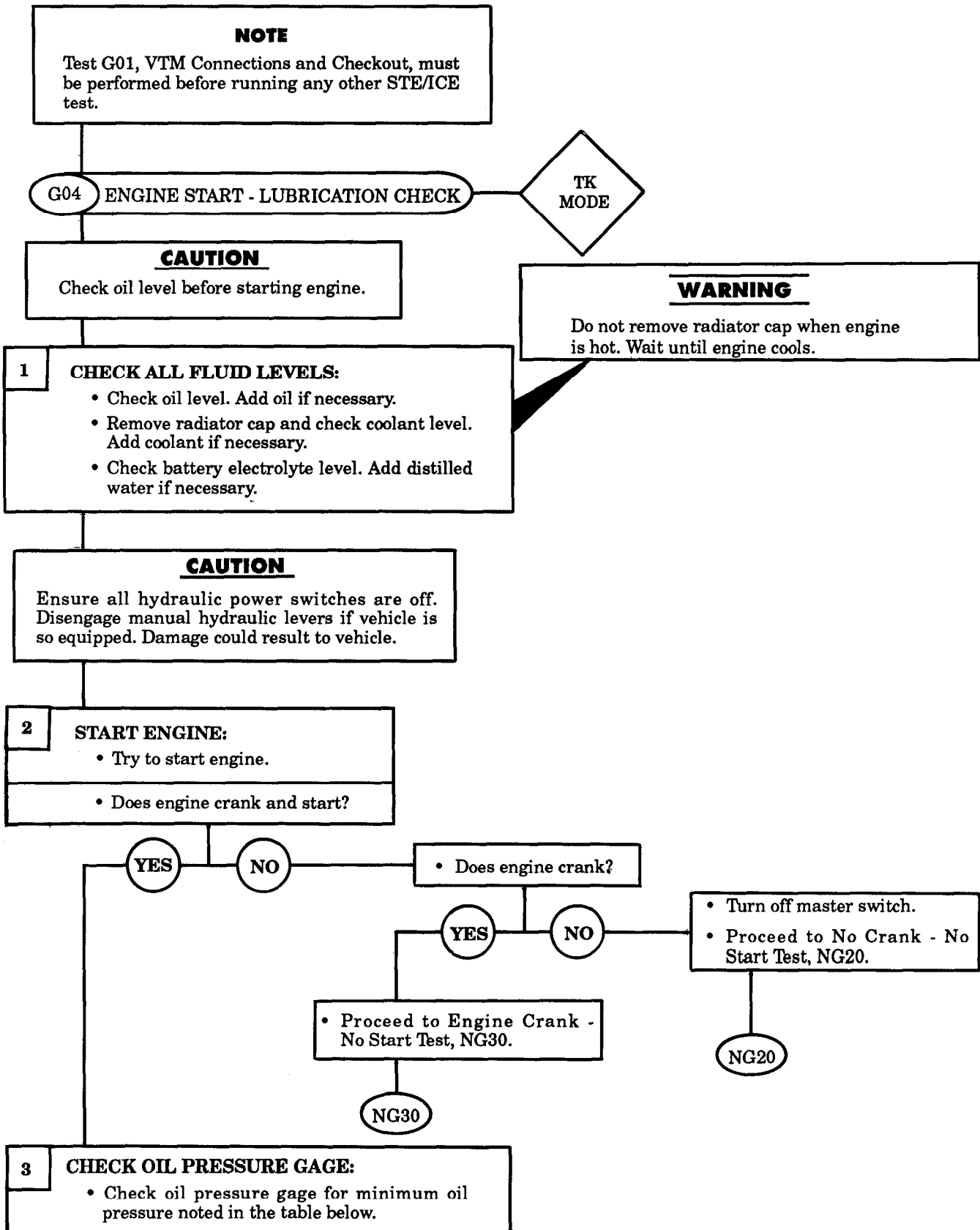

Table 2-10. STE/ICE Go-Chain Tests (Contd).

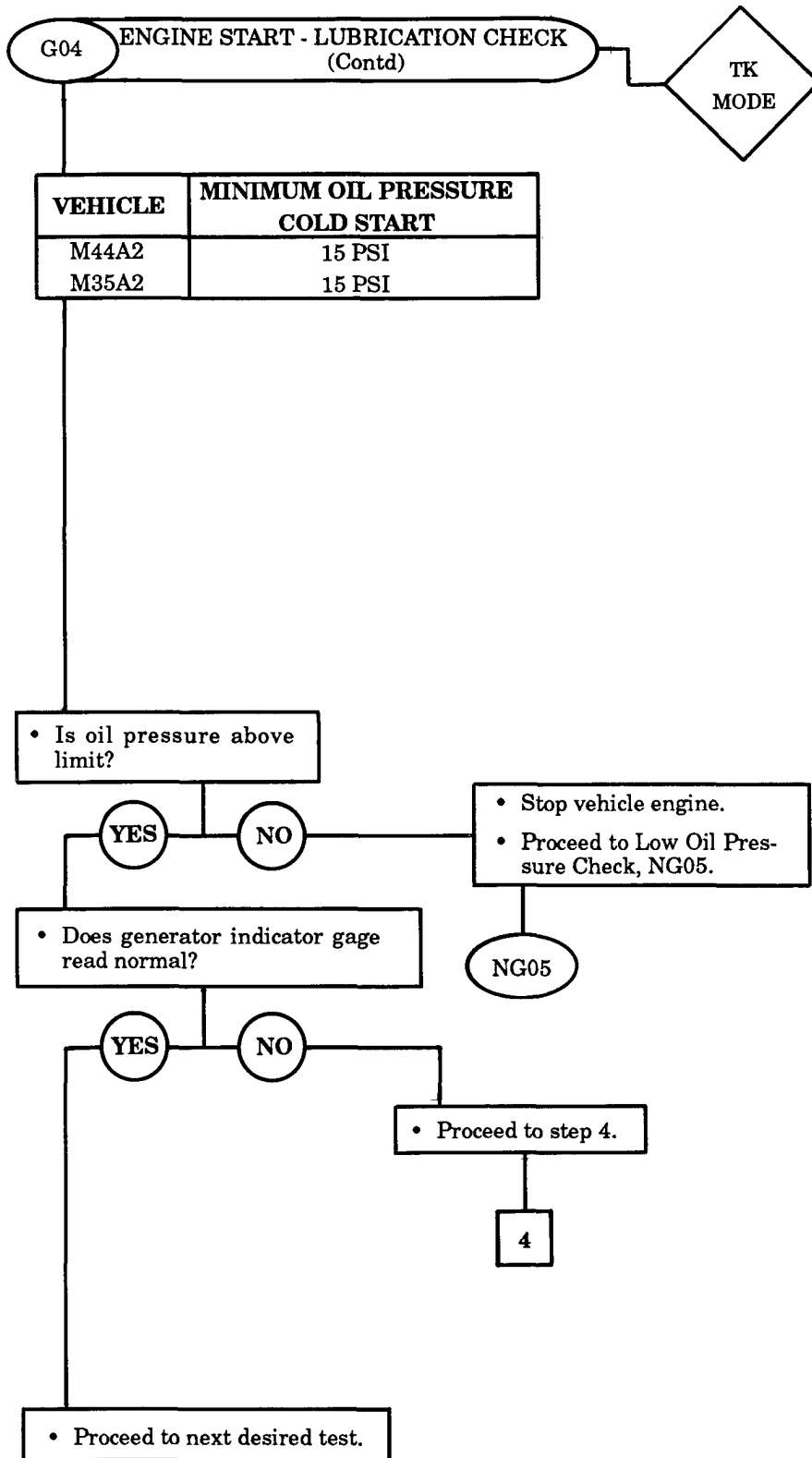

Table 2-10. STE/ICE Go-Chain Tests (Contd).

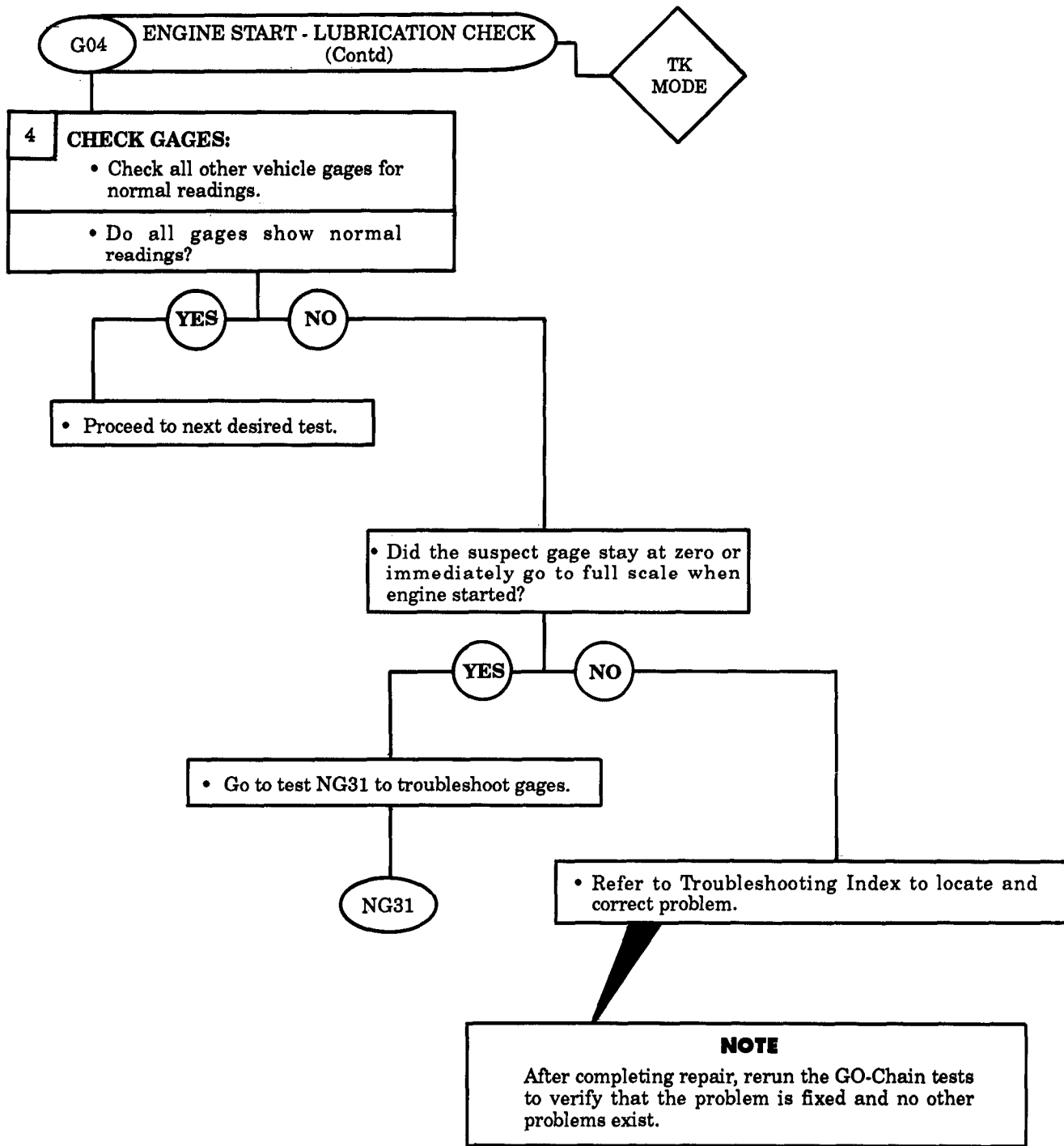

Table 2-10. STE/ICE Go-Chain Tests (Contd).

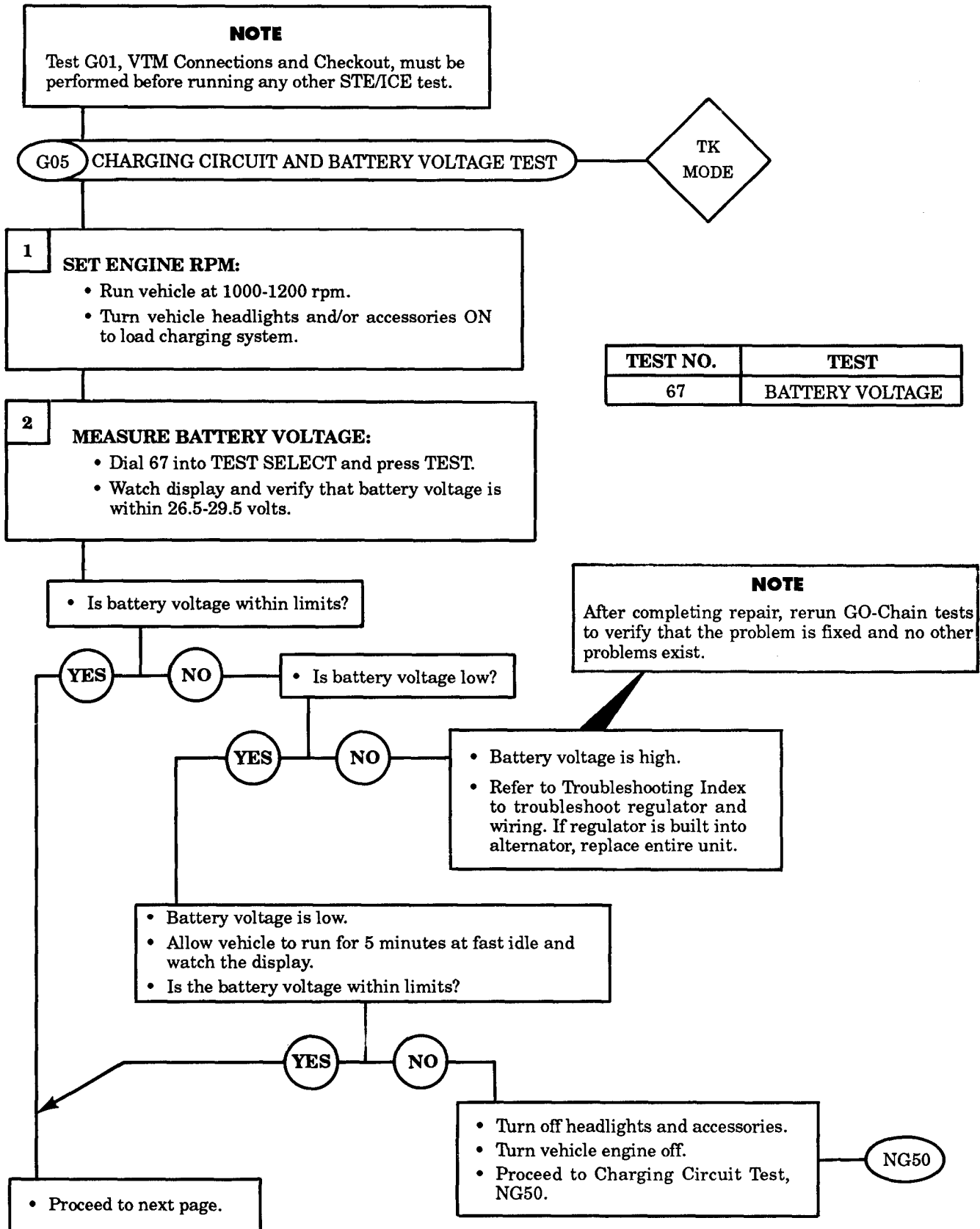



Table 2-10. STE/ICE Go-Chain Tests (Contd).

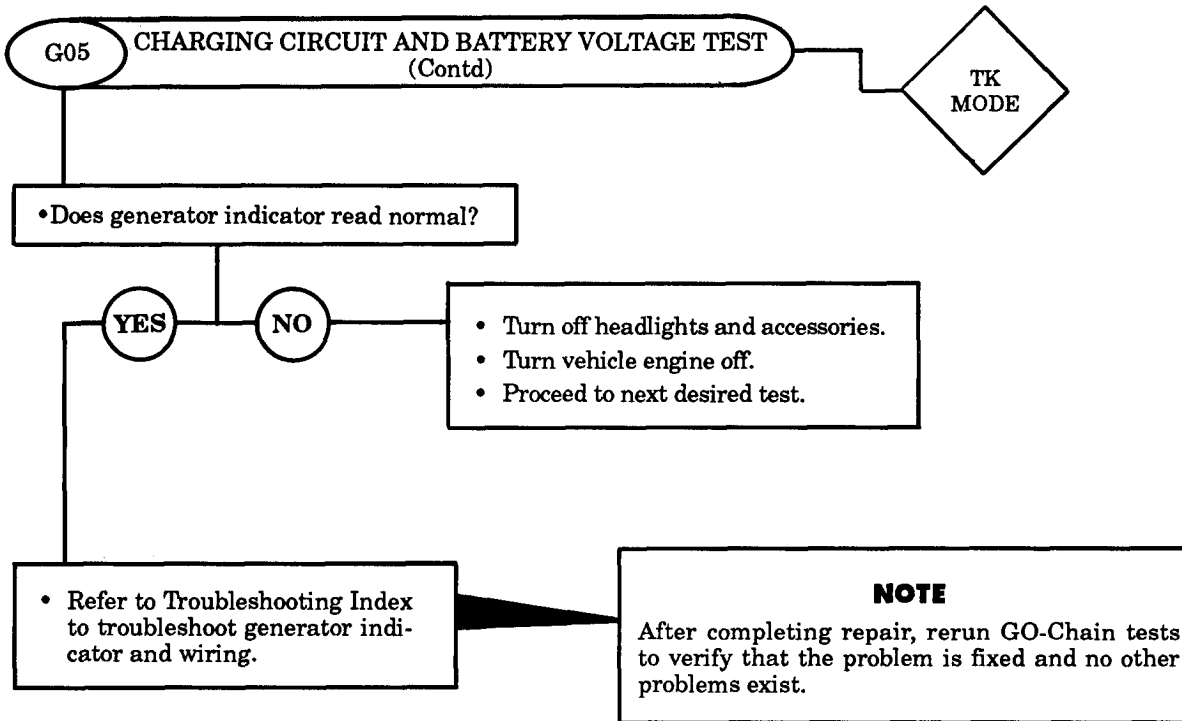

Table 2-10. STE/ICE Go-Chain Tests (Contd).

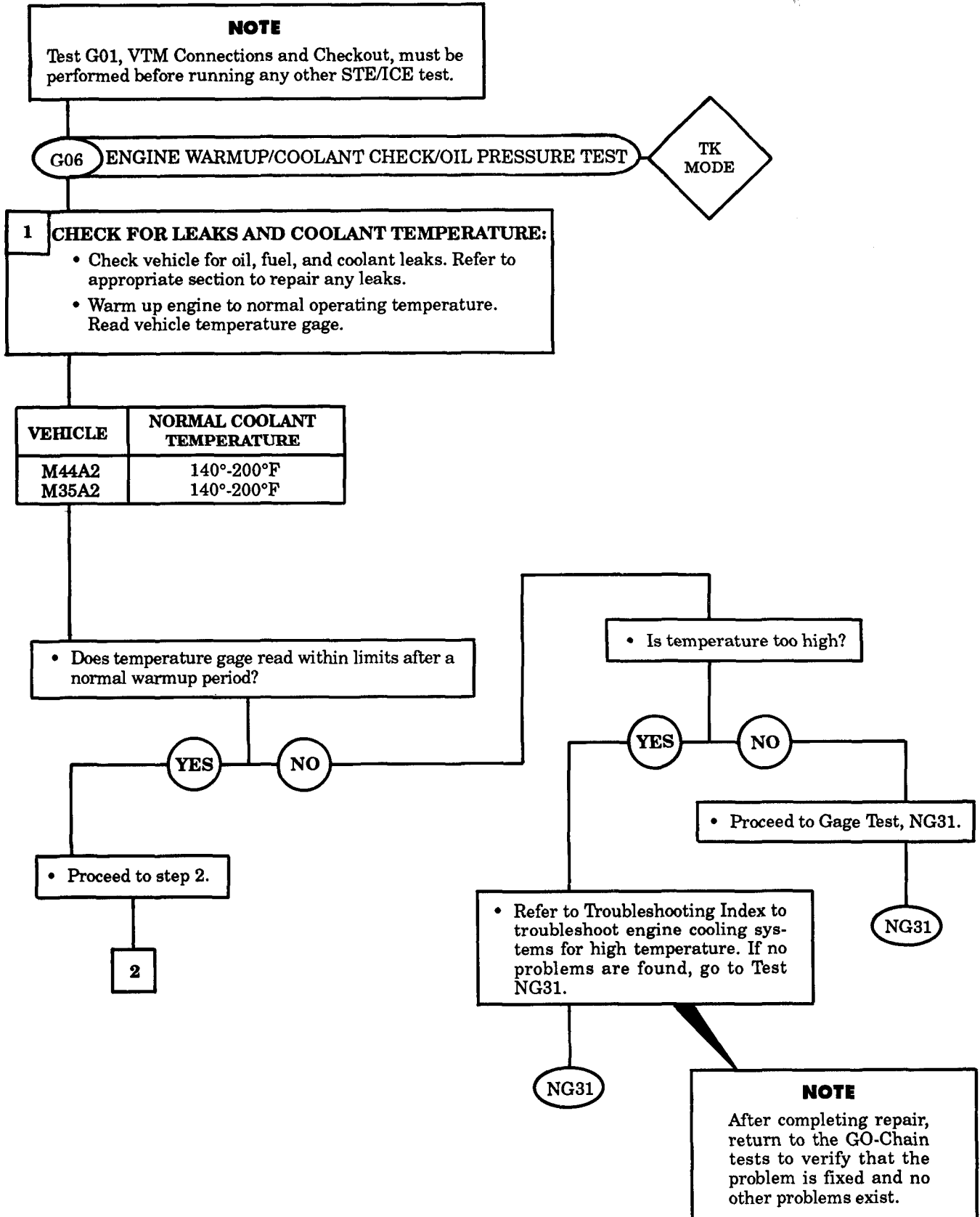

Table 2-10. STE/ICE Go-Chain Tests (Contd).

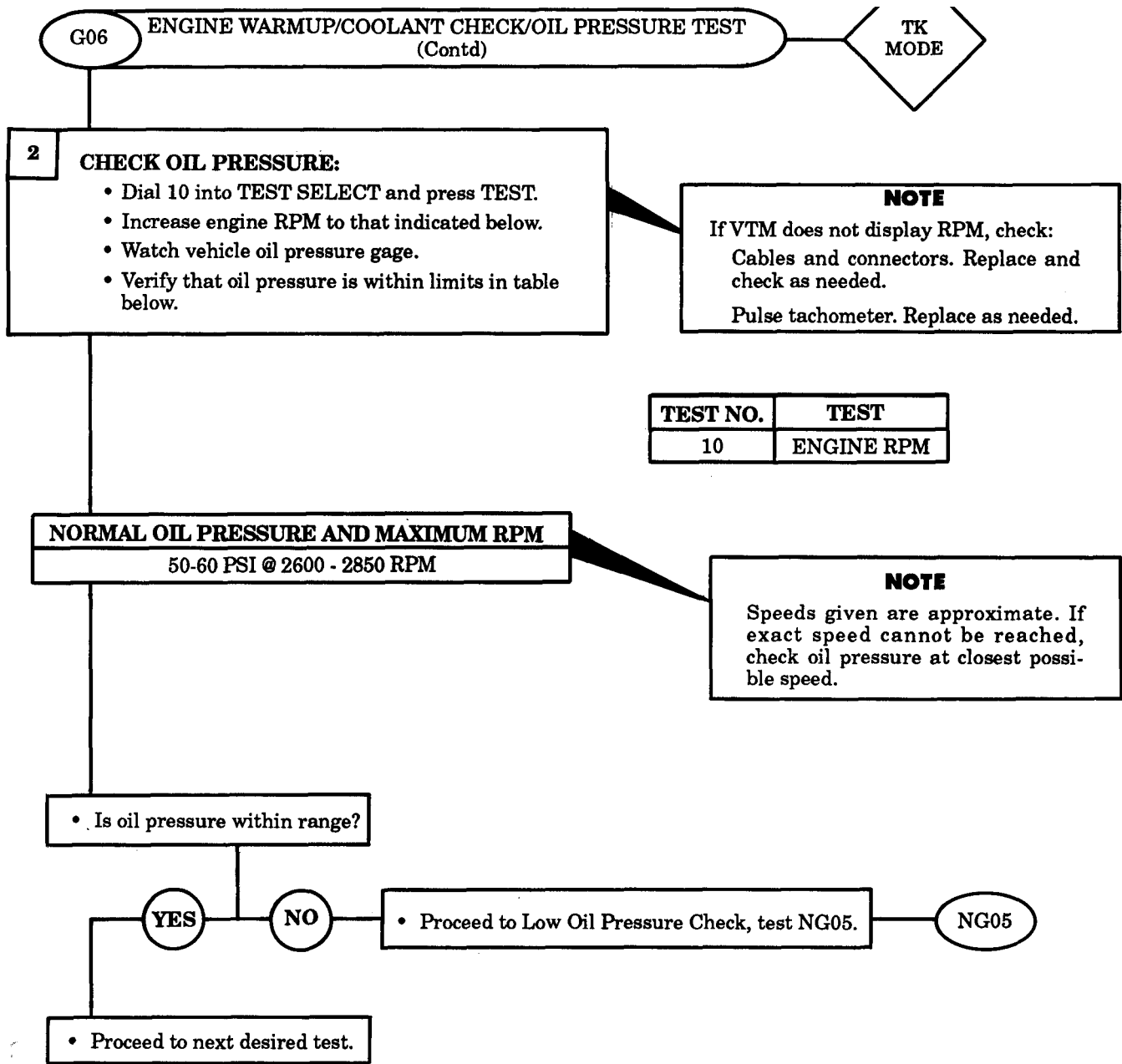

Table 2-10. STE/ICE Go-Chain Tests (Contd).

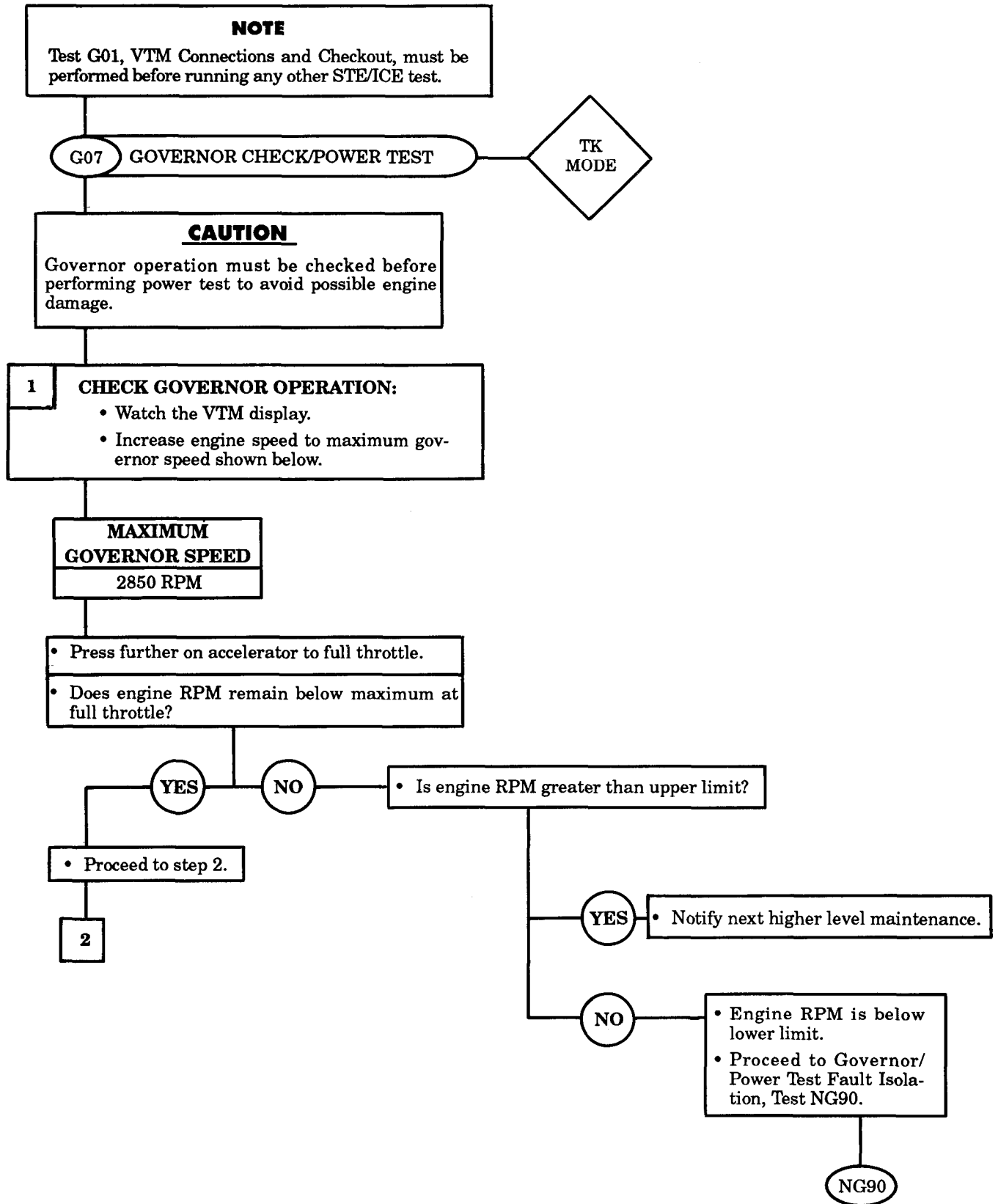

Table 2-10. STE/ICE Go-Chain Tests (Contd).

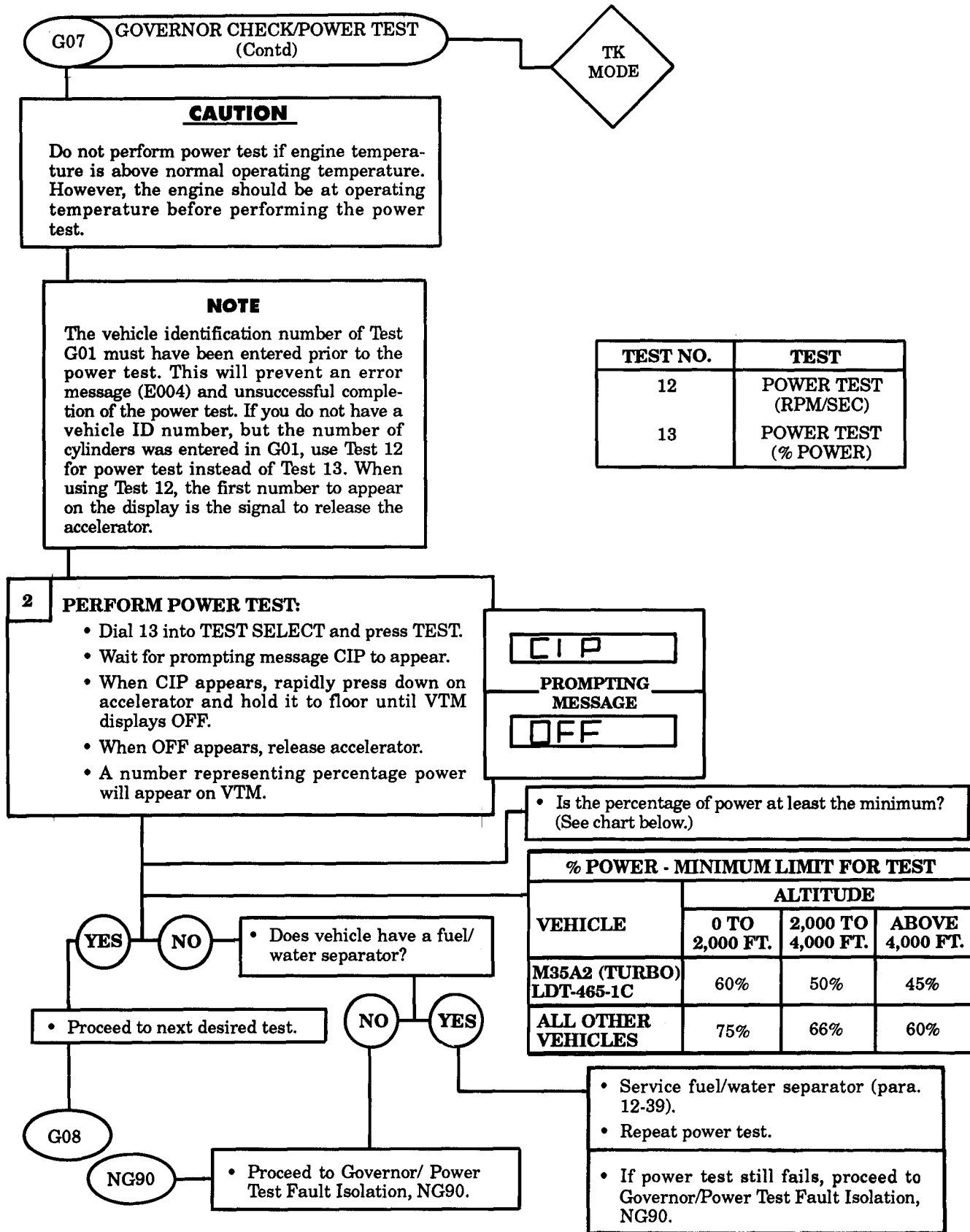

Table 2-10. STE/ICE Go-Chain Tests (Contd).

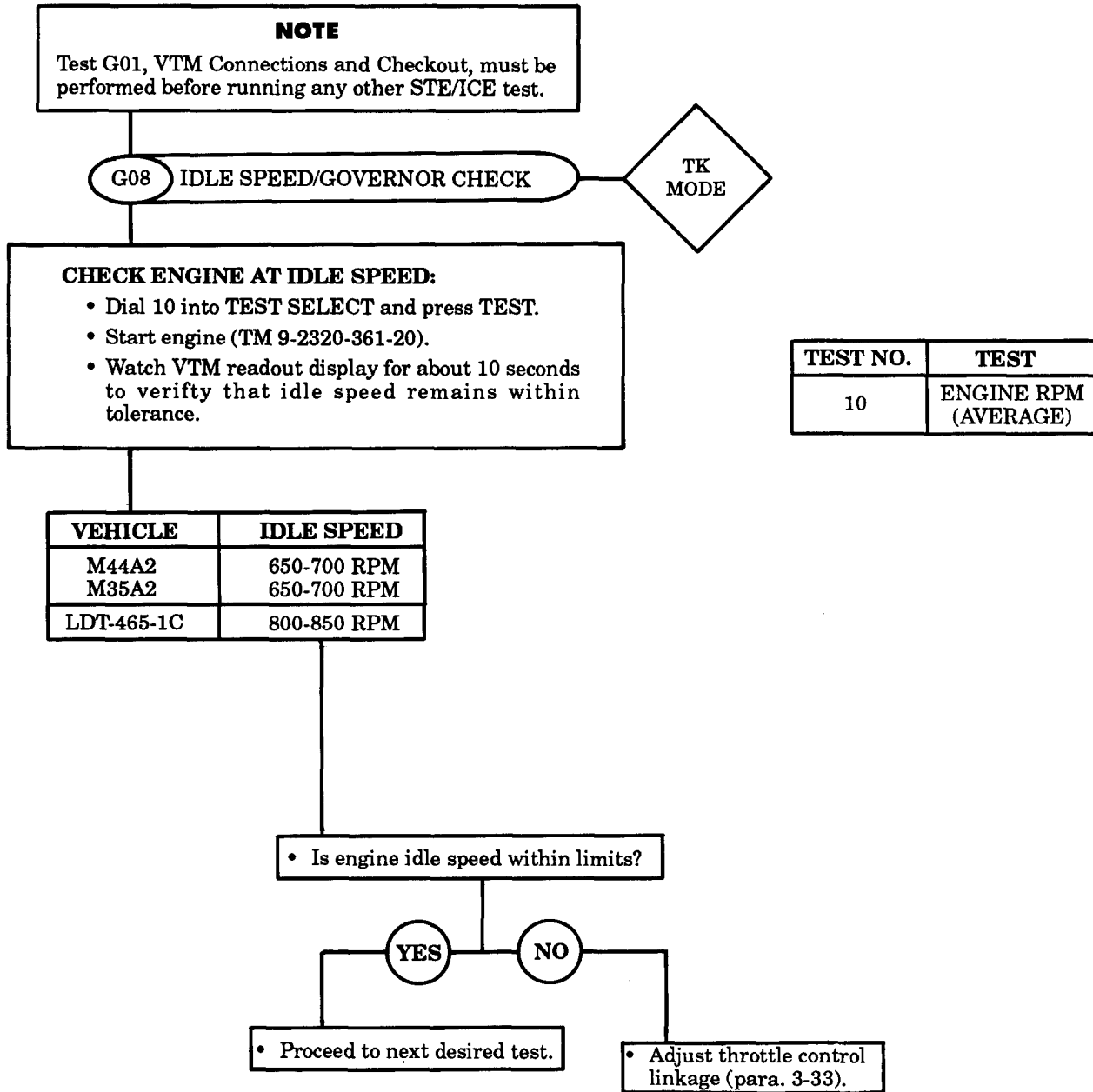

Table 2-10. STE/ICE Go-Chain Tests (Contd).

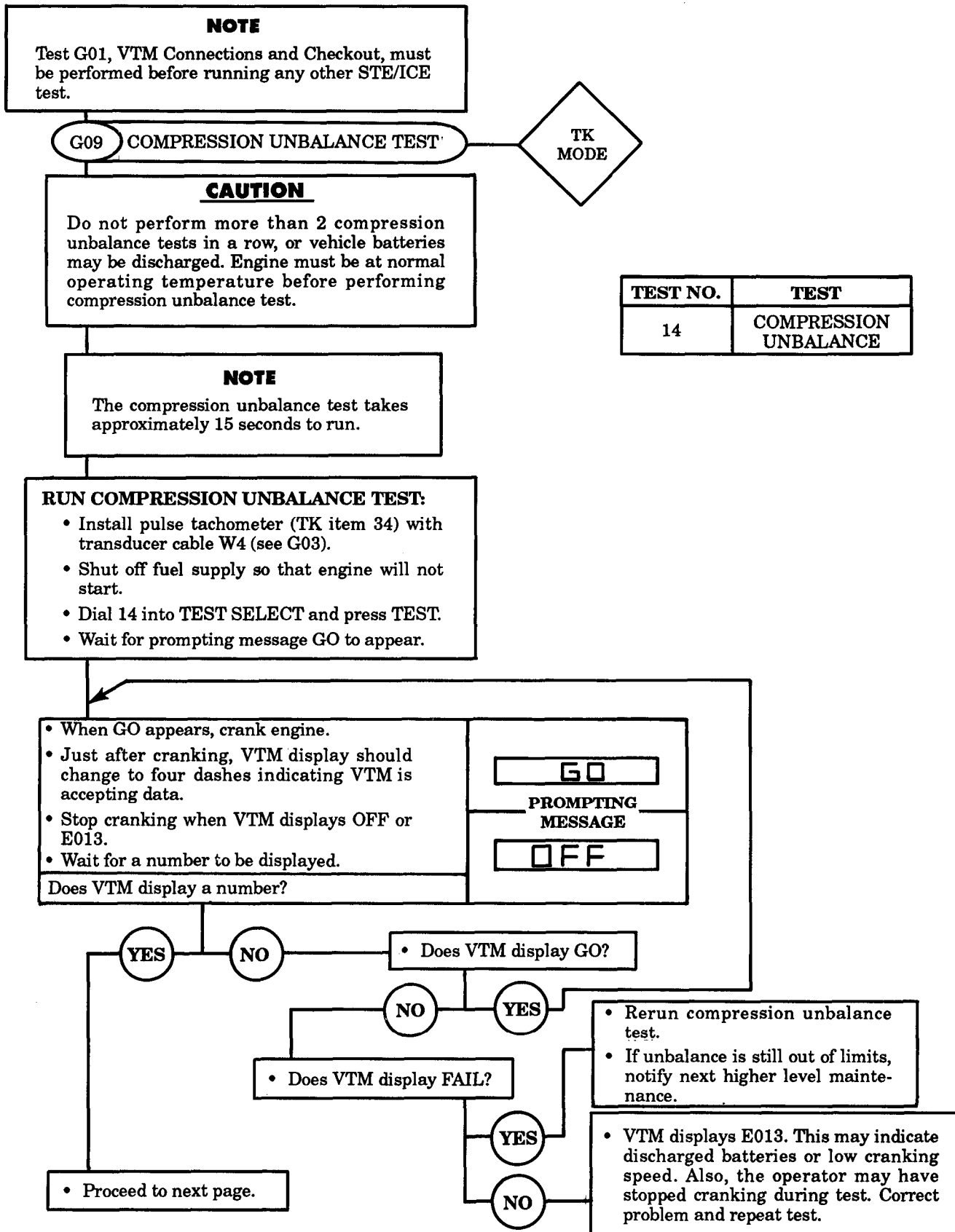

Table 2-10. STE/ICE Go-Chain Tests (Contd).

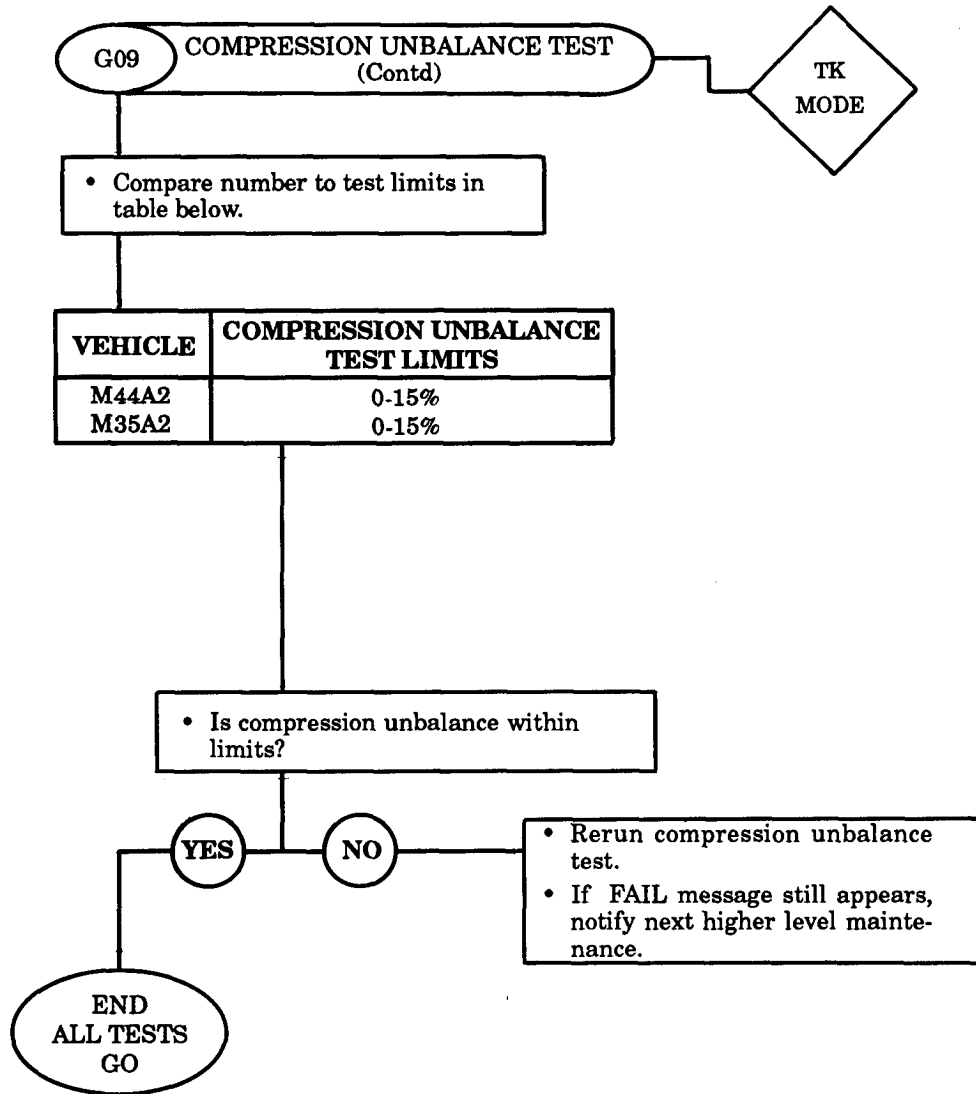
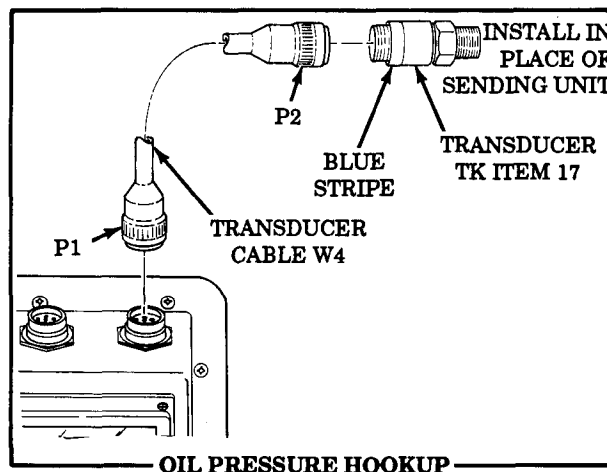



Table 2-11. STE/ICE No-Go Chain Tests



**NOTE**  
Test G01, VTM Connections and Checkout, must be performed before running any other STE/ICE test.

NG05 LOW OIL PRESSURE CHECK

TK MODE

- 1 INSTALL TRANSDUCER - DO OFFSET**
- Stop vehicle engine.
  - Remove oil pressure sending unit (para. 4-23).
  - Install pressure transducer, TK Item 17 (blue stripe), in place of sending unit on engine.
  - Connect P1 of transducer cable W4 to J2 on VTM.
  - Connect P2 of transducer cable to connector on pressure transducer.
  - Install pulse tachometer.
  - Connect P2 of W4 cable to VTM J3.
  - Connect P1 of W4 cable to pulse tachometer.

TEST NO.	TEST
01	INTERLEAVE
50	0-1000 PSIG PRESSURE

- Dial 50 into TEST SELECT.
- Press and hold TEST until CAL message appears on display.
- Release TEST.
- Wait for offset value to appear on display.
- Is offset value within limits of -150 to +150?

CAL  
PROMPTING MESSAGE

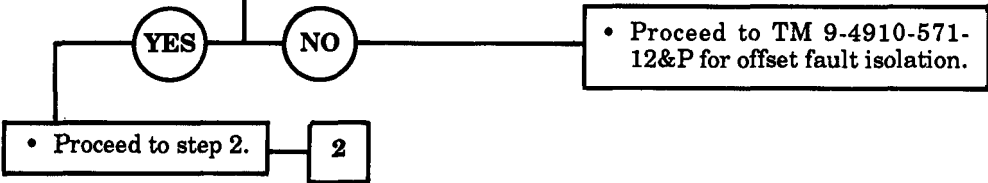

Table 2-11. STE/ICE No-Go Chain Tests (Contd).

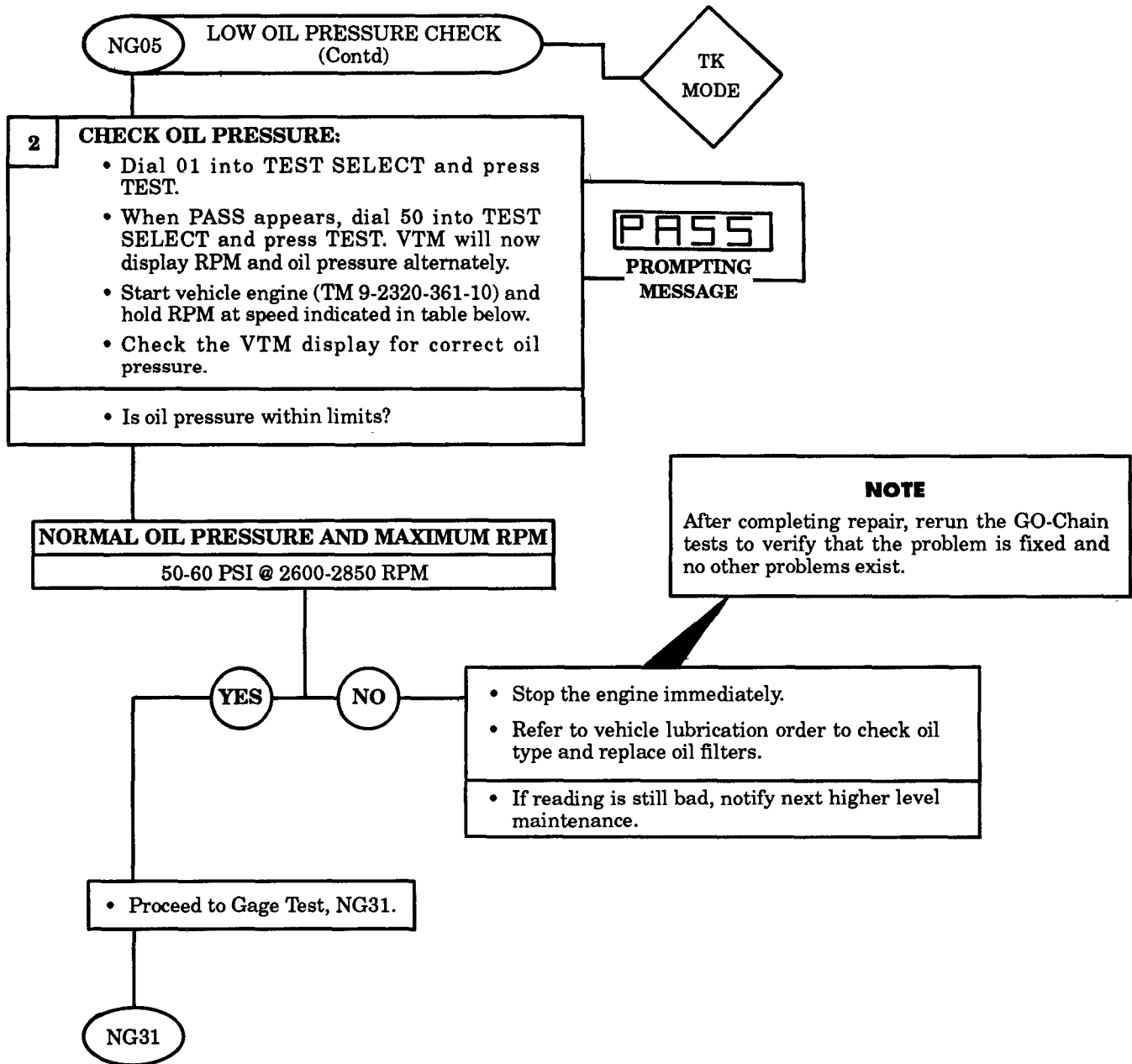

Table 2-11. STE/ICE No-Go Chain Tests (Contd).

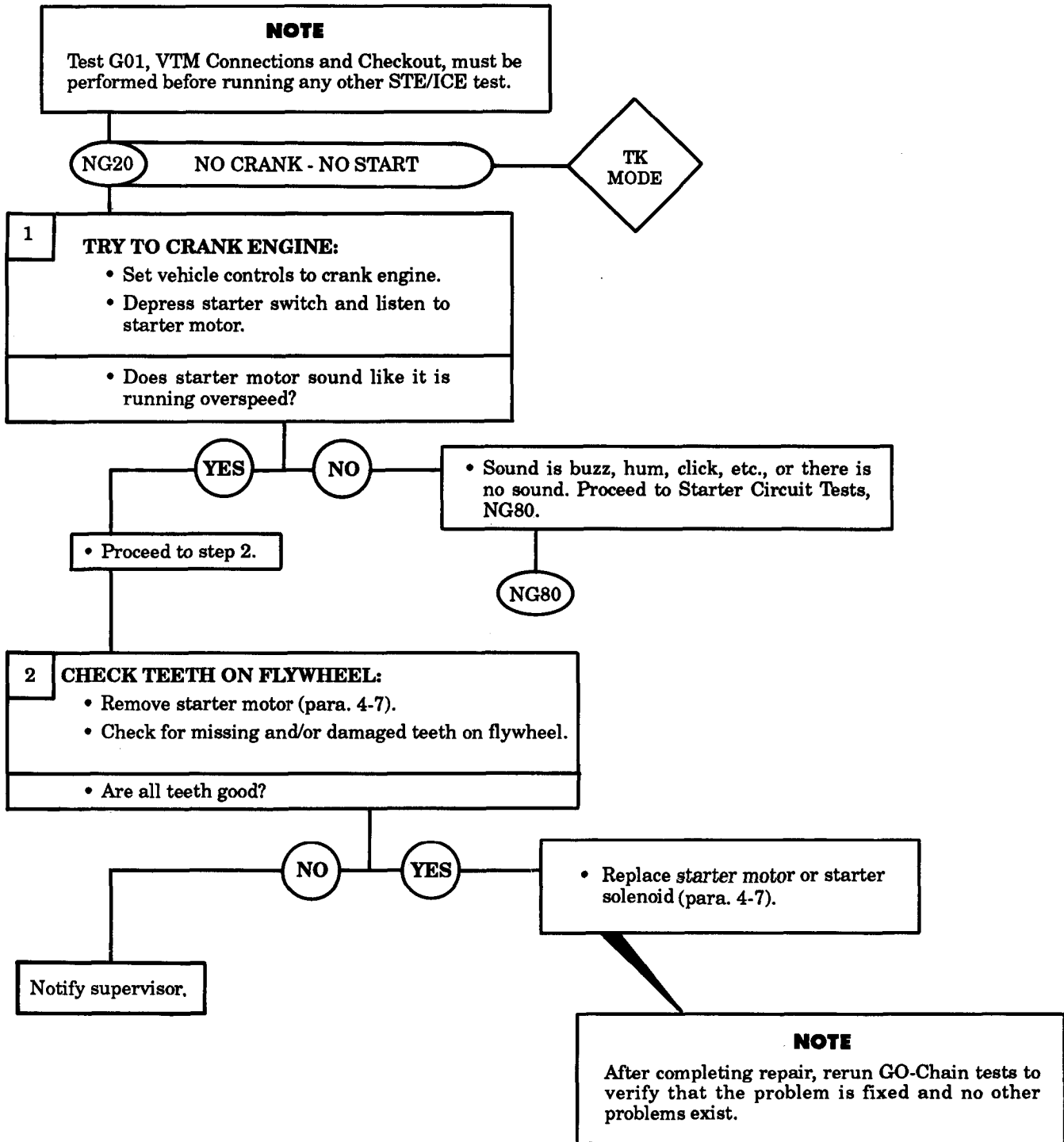

Table 2-11. STE/ICE No-Go Chain Tests (Contd).

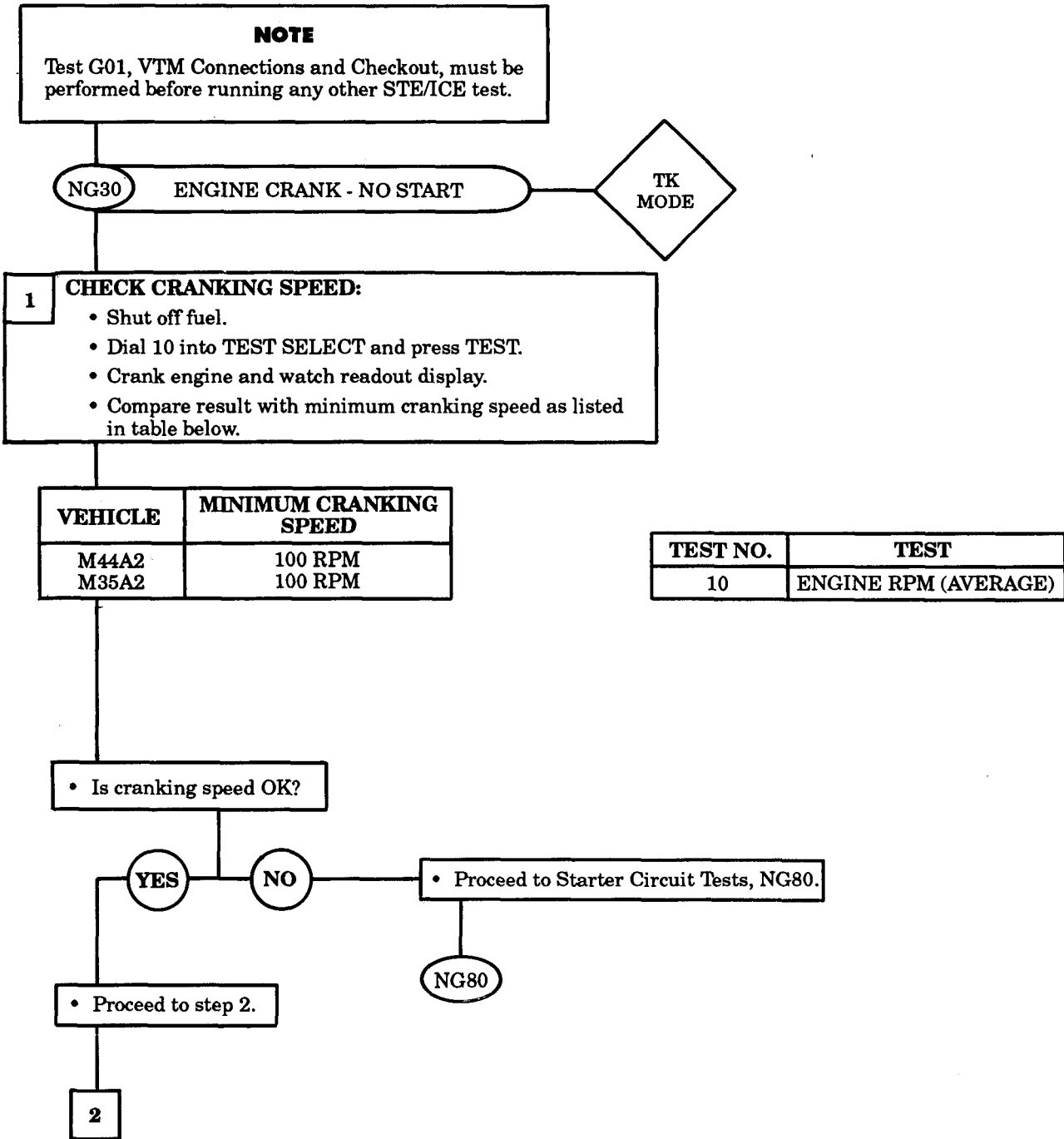

Table 2-11. STE/ICE No-Go Chain Tests (Contd).

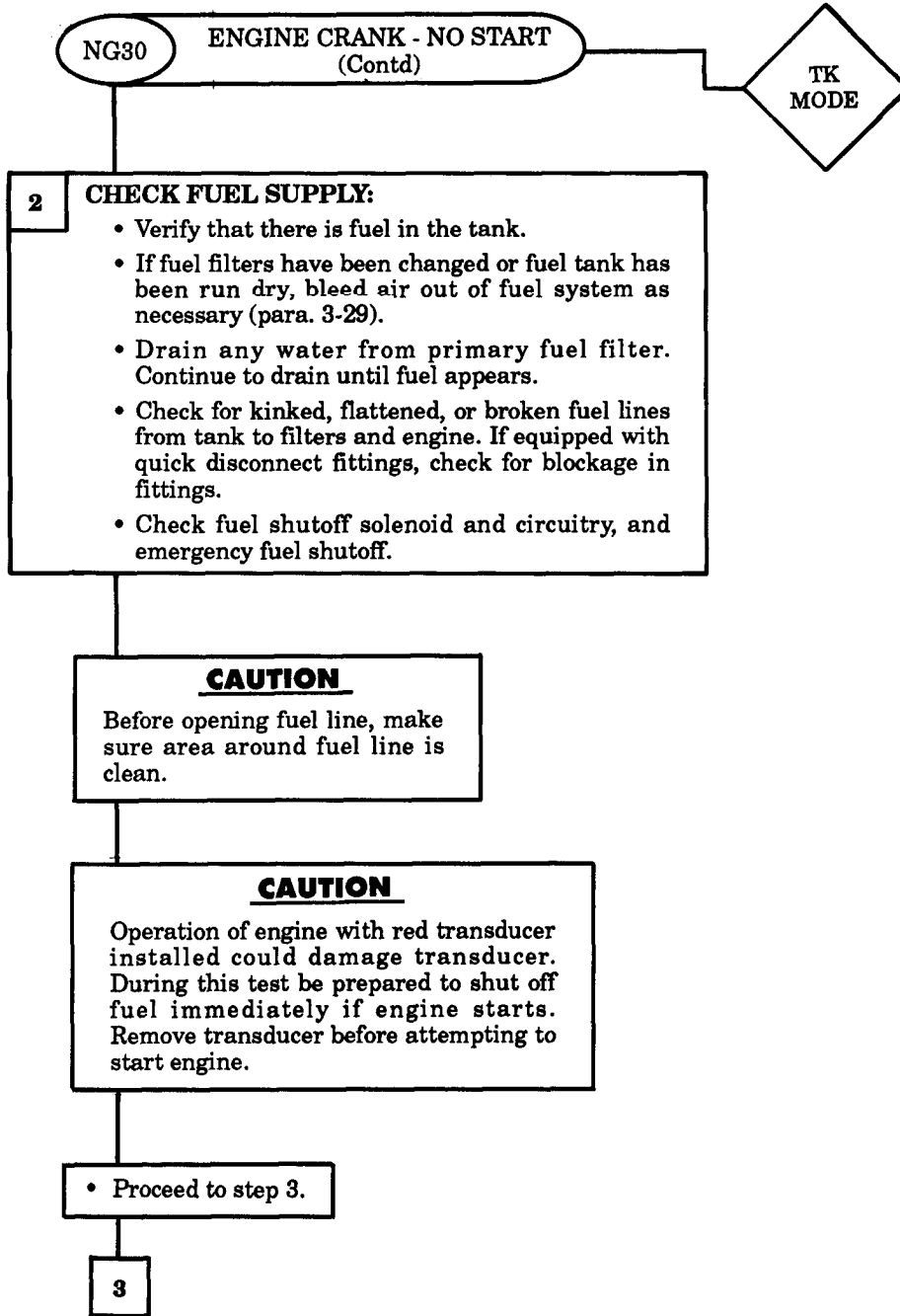
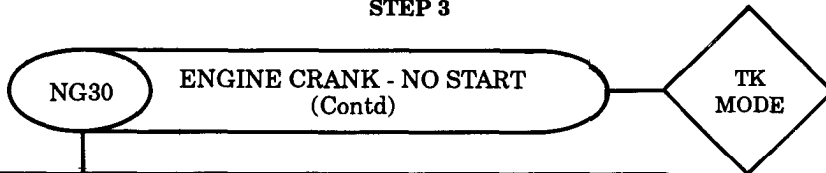
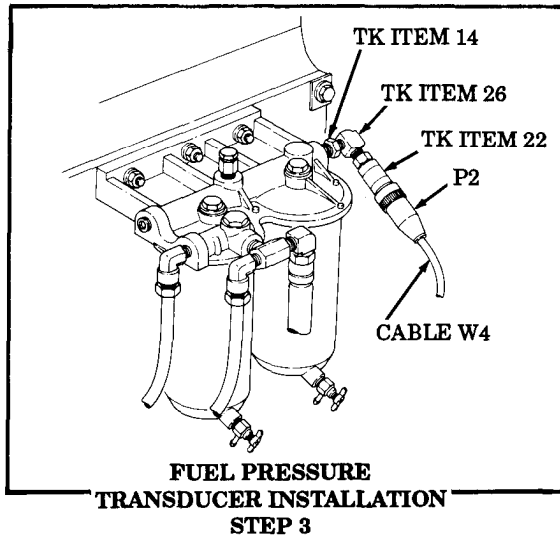

Table 2-11. STE/ICE No-Go Chain Tests (Contd).



**3 INSTALL TRANSDUCER:**

- Install pressure transducer (red stripe) in outlet side of secondary fuel filter.
- Connect P1 of transducer cable W4 to J2 on VTM.
- Connect P2 of transducer cable to connector on transducer.

TEST NO.	TEST
49	0-25 PSIG PRESSURE

- Dial 49 into TEST SELECT and press TEST.
- Press and hold TEST until CAL message appears on display.
- Release TEST.
- Wait for offset value to appear on display.

• Is offset value within range of -4 to +4?

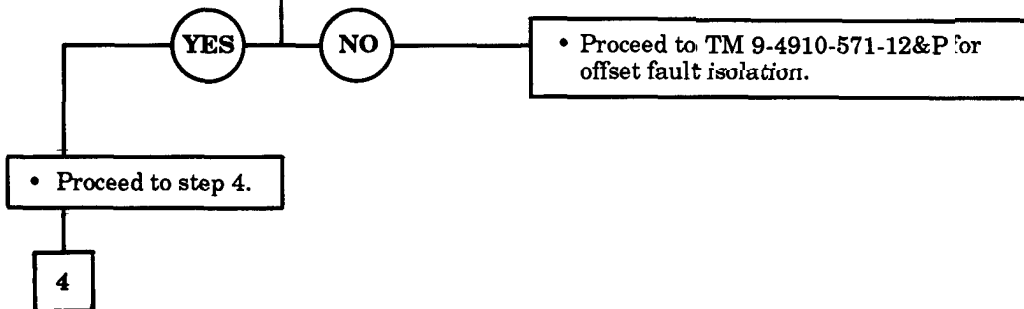

Table 2-11. STE/ICE No-Go Chain Tests (Contd).

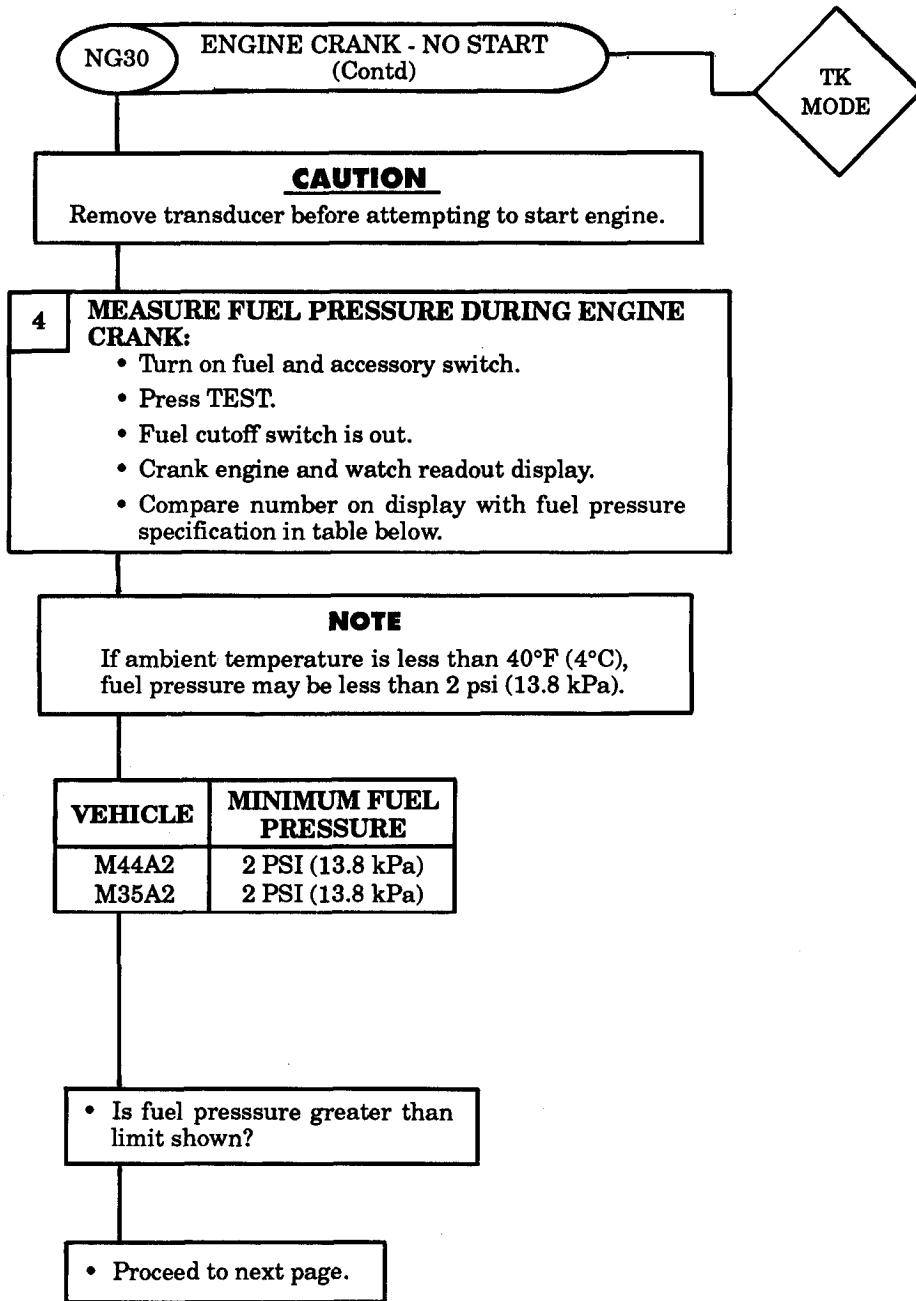

Table 2-11. STE/ICE No-Go Chain Tests (Contd).

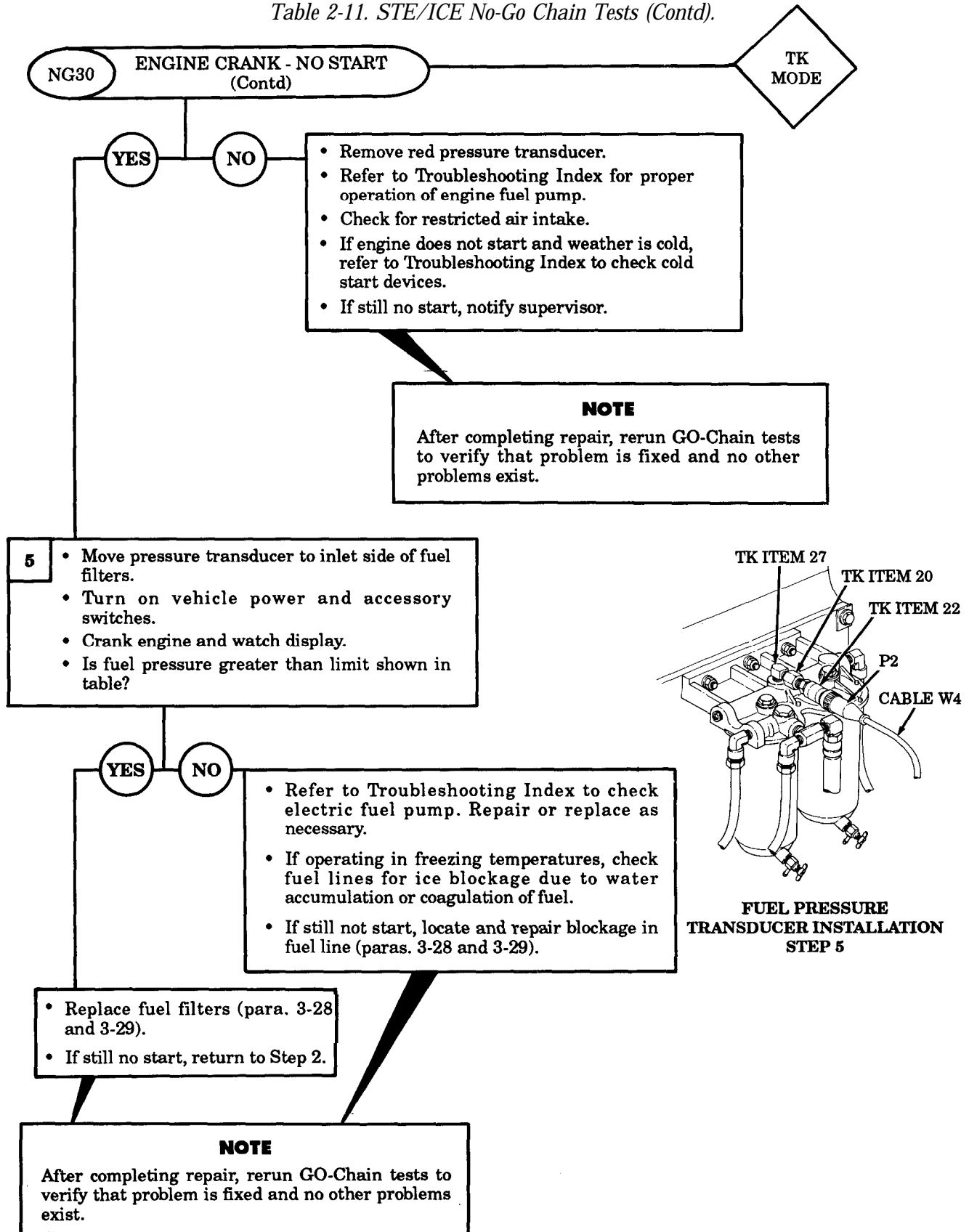



Table 2-11. STE/ICE No-Go Chain Tests (Contd).

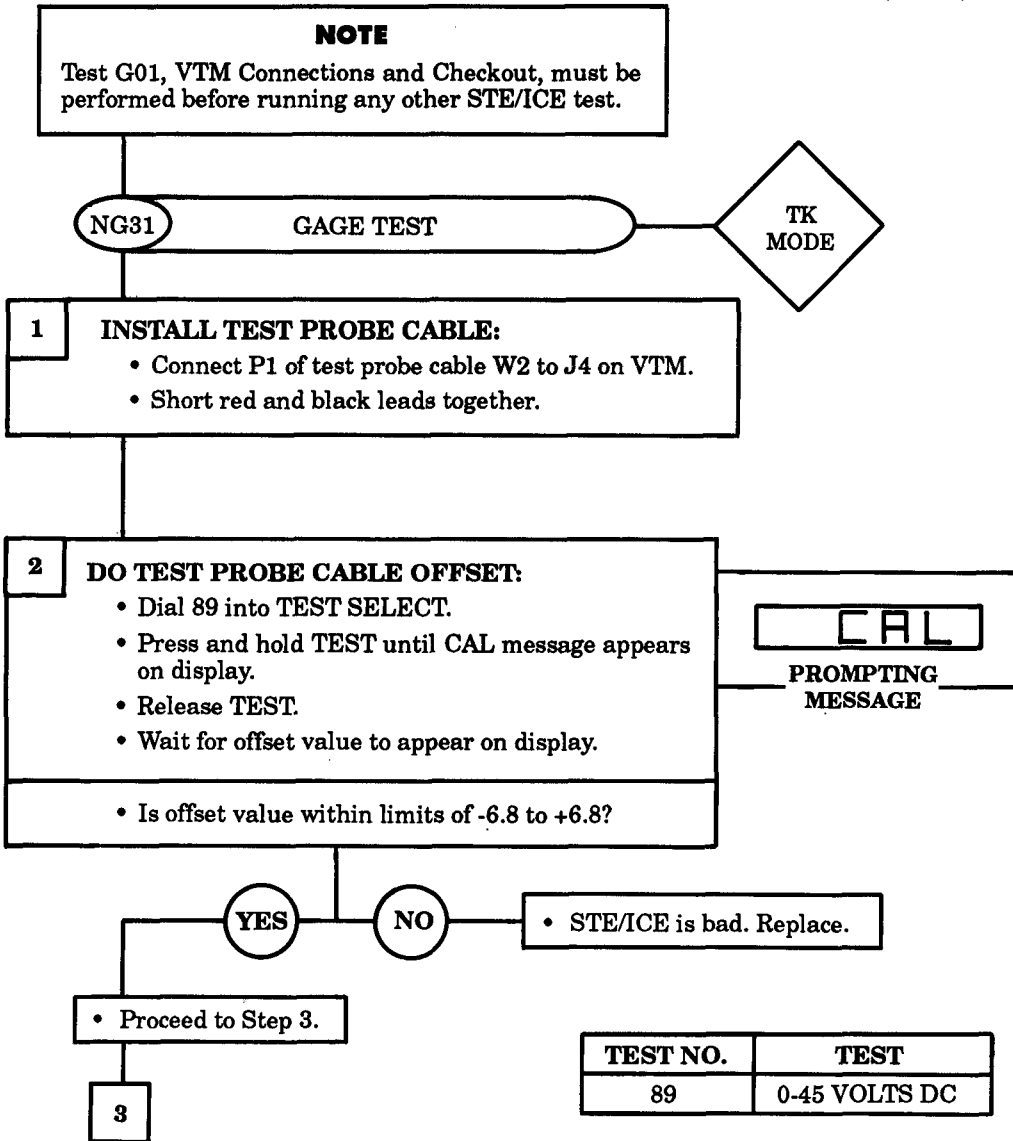
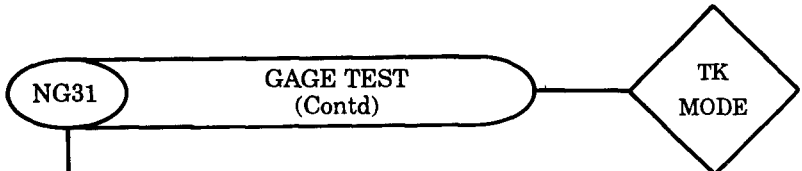
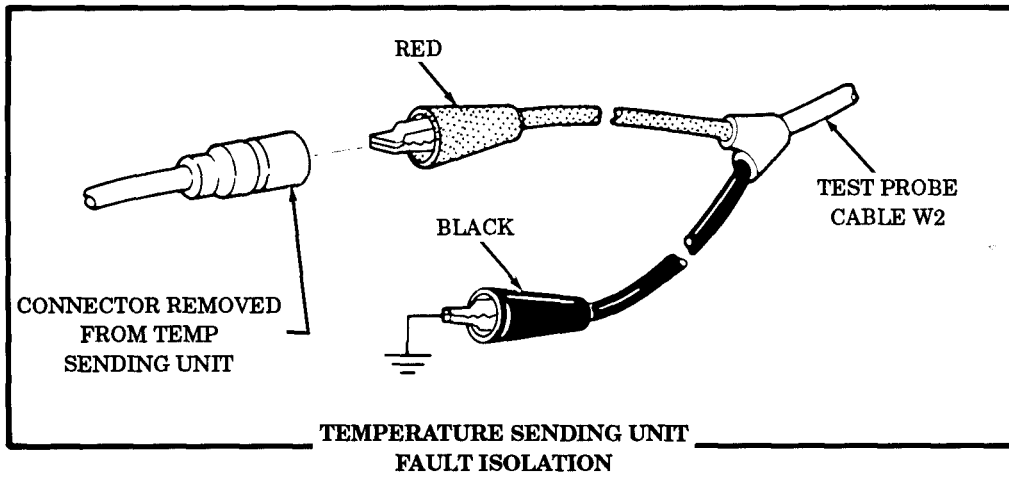

Table 2-11. STE/ICE No-Go Chain Tests (Contd).



**3** ISOLATE FAULT TO SENDING UNIT OR GAGE:

- Remove wire from sending unit on vehicle.
- Connect red clip lead of W2 to wire removed from sending unit.
- Connect black clip lead to a good ground.
- Press TEST.
- Turn vehicle accessory switch ON.

---

- Does VTM indicate battery voltage?

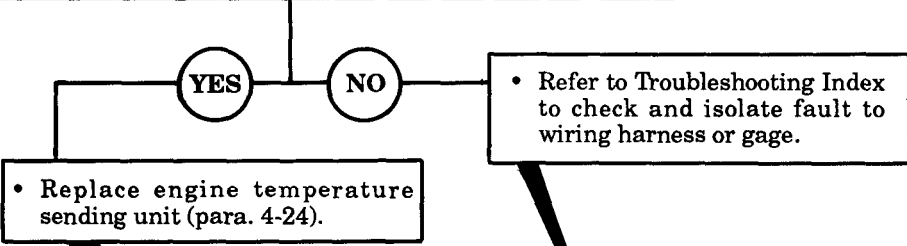

**NOTE**  
 After completing repair, rerun GO-Chain tests to verify that problem is fixed and no other problems exist.

Table 2-11. STE/ICE No-Go Chain Tests (Contd).

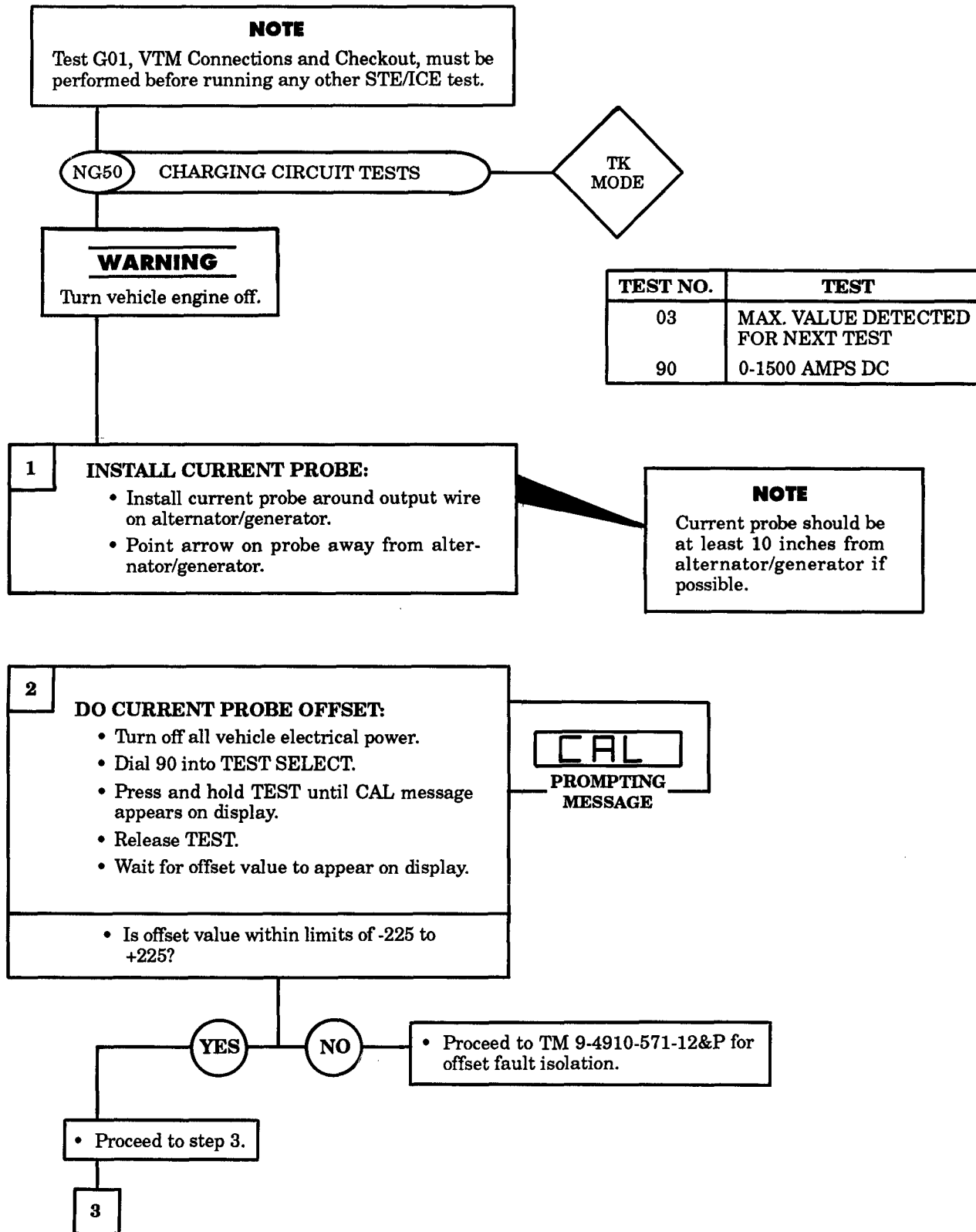

Table 2-11. STE/ICE No-Go Chain Tests (Contd).

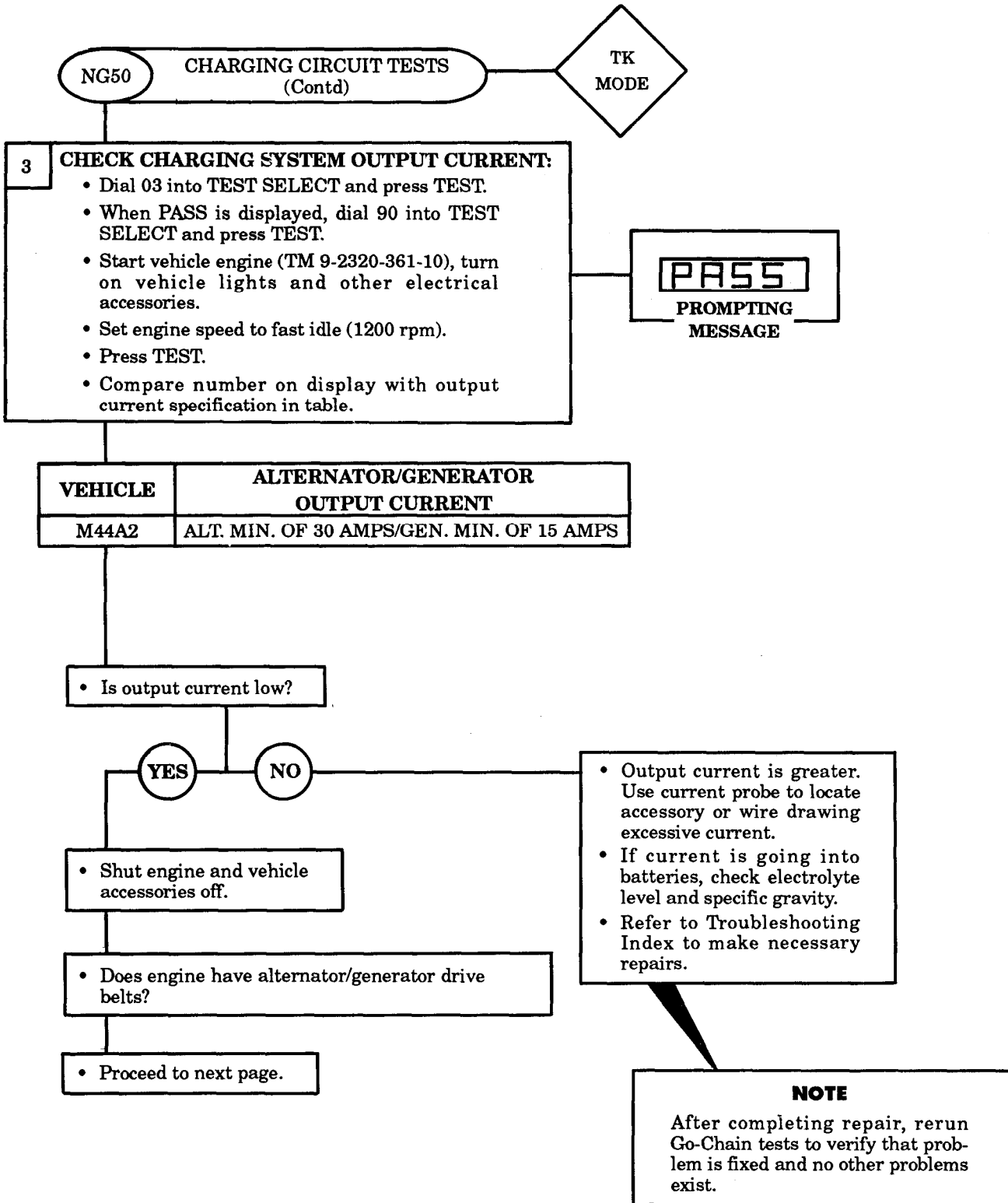

Table 2-11. STE/ICE No-Go Chain Tests (Contd).

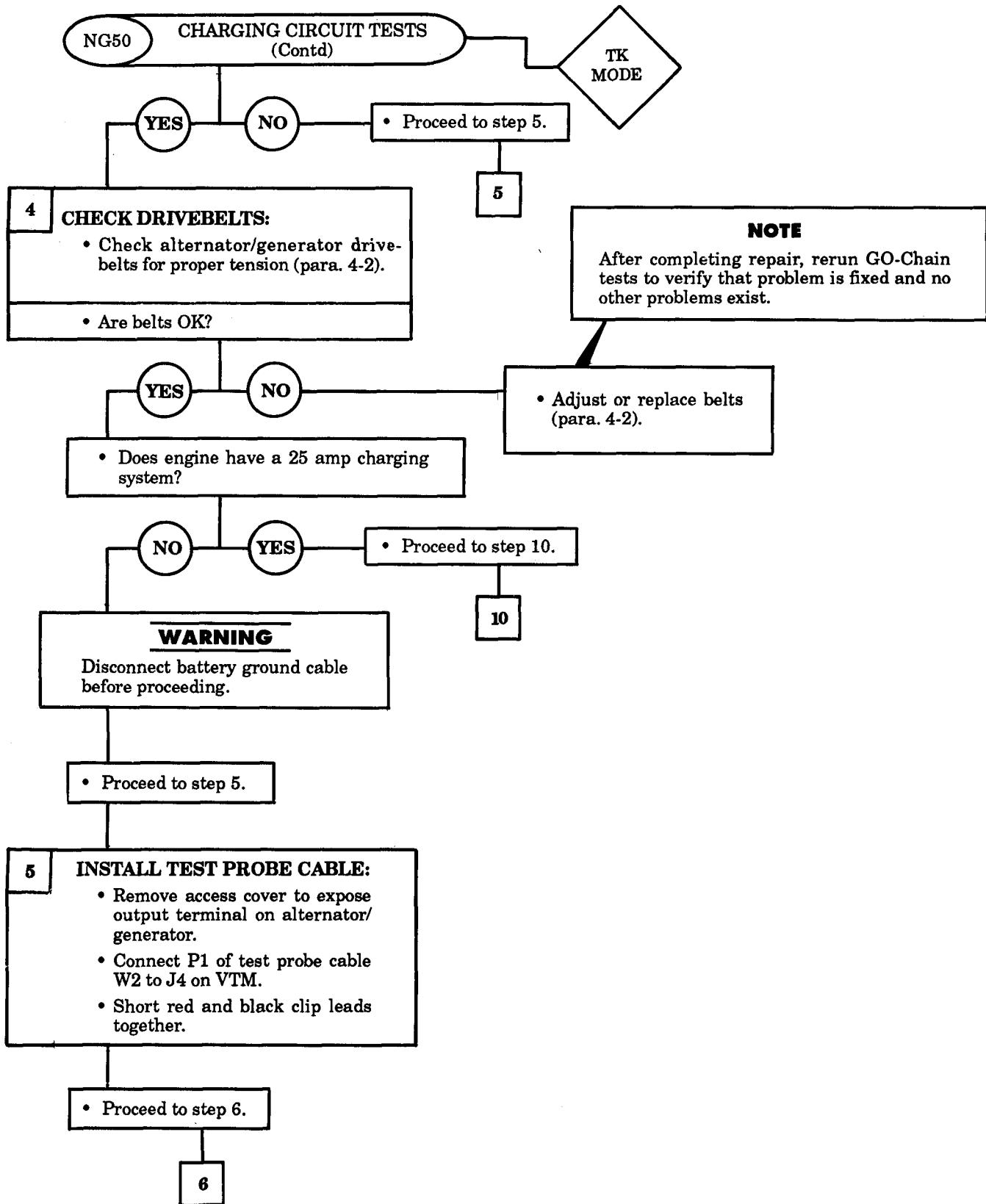

Table 2-11. STE/ICE No-Go Chain Tests (Contd).

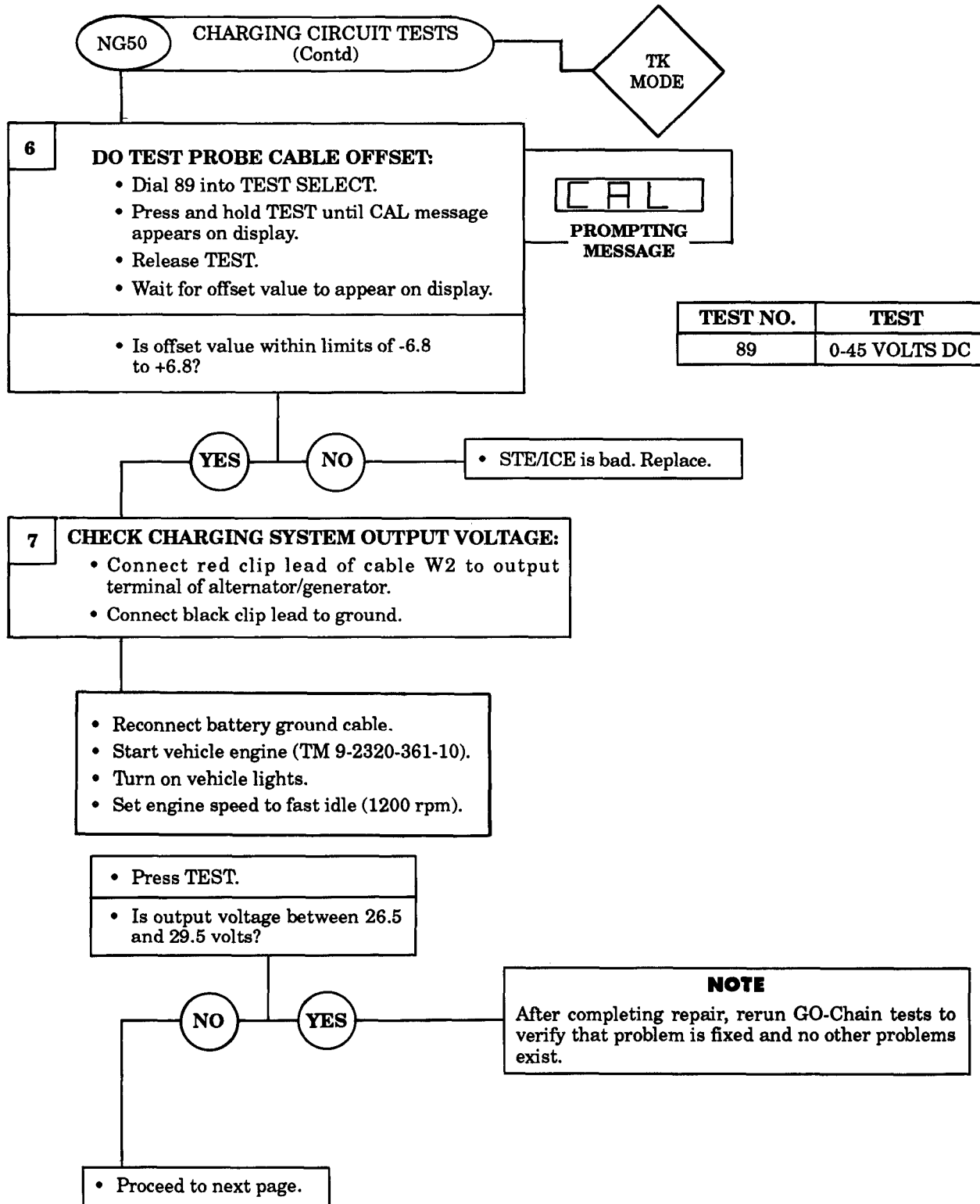

Table 2-11. STE/ICE No-Go Chain Tests (Contd).

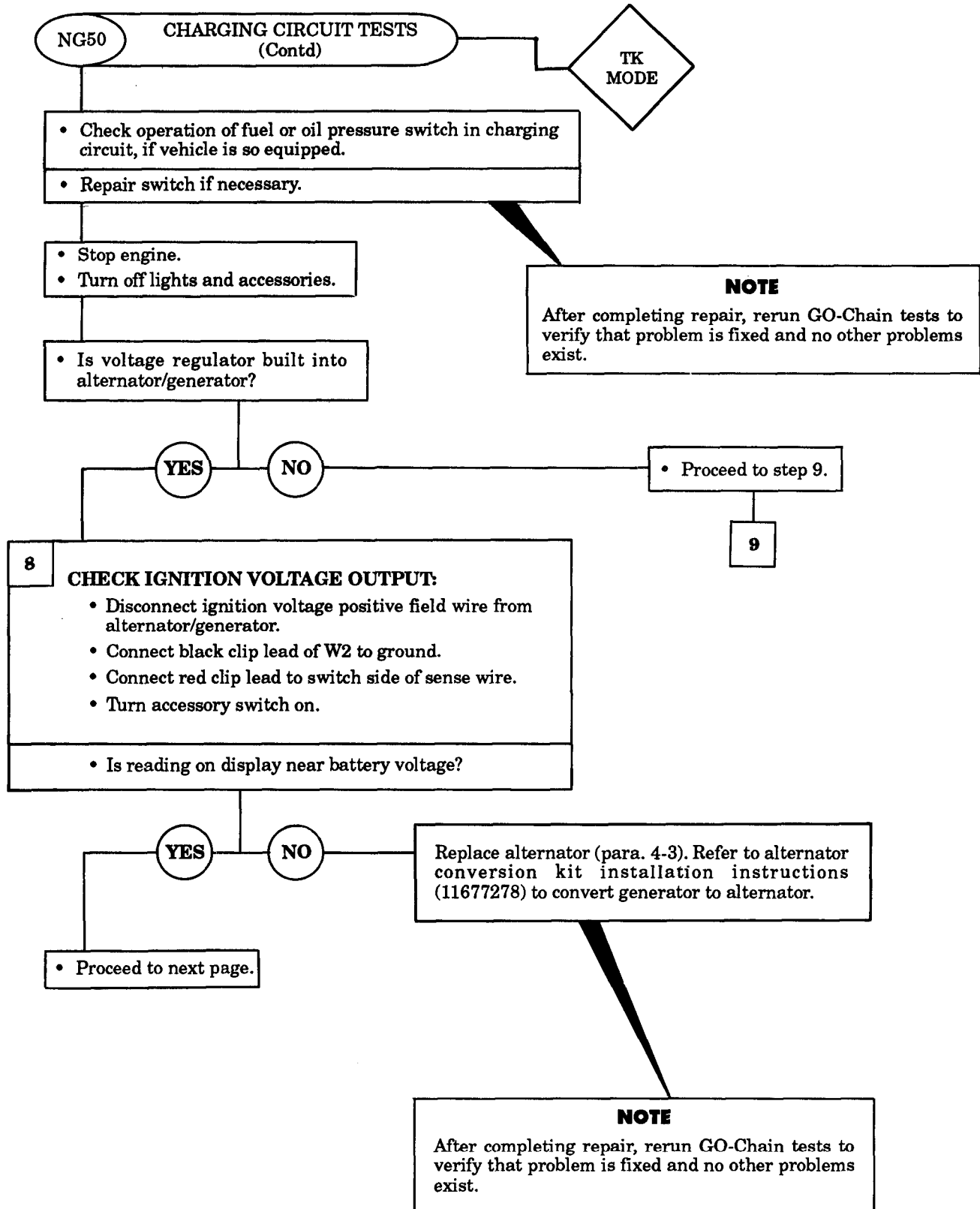

Table 2-11. STE/ICE No-Go Chain Tests (Contd).

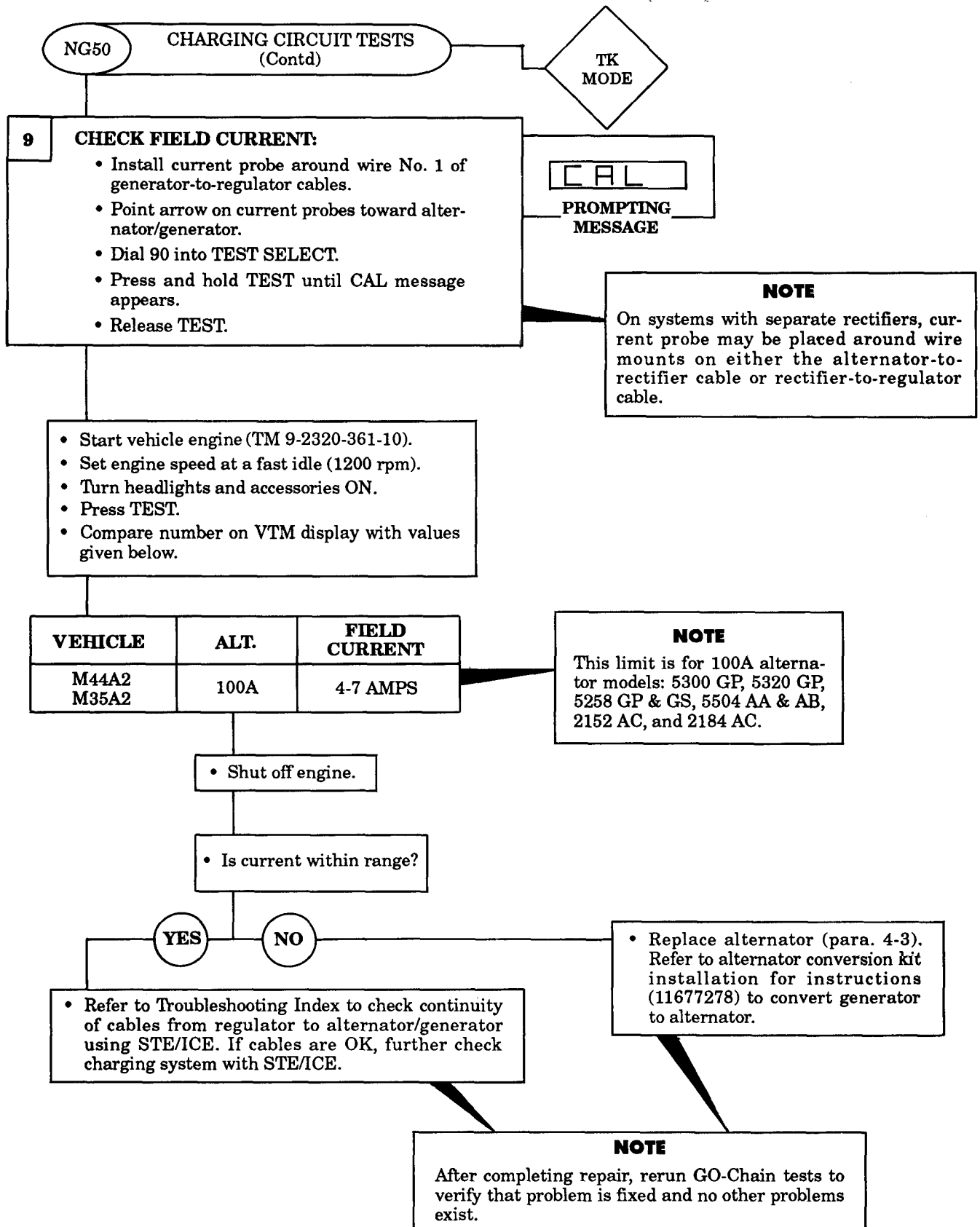
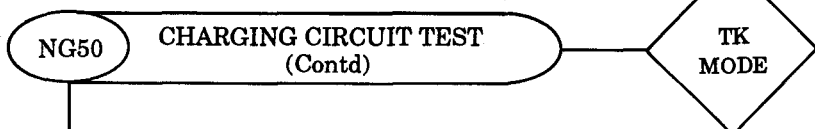
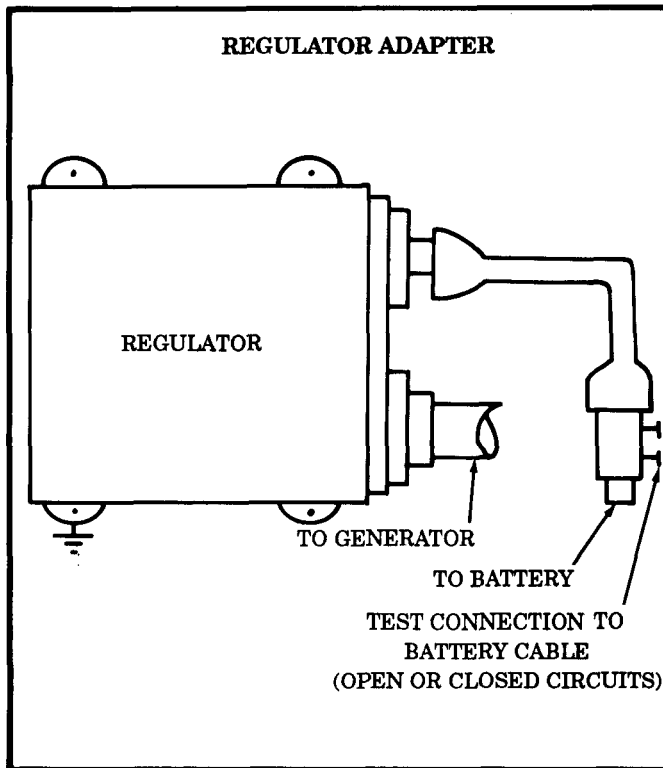
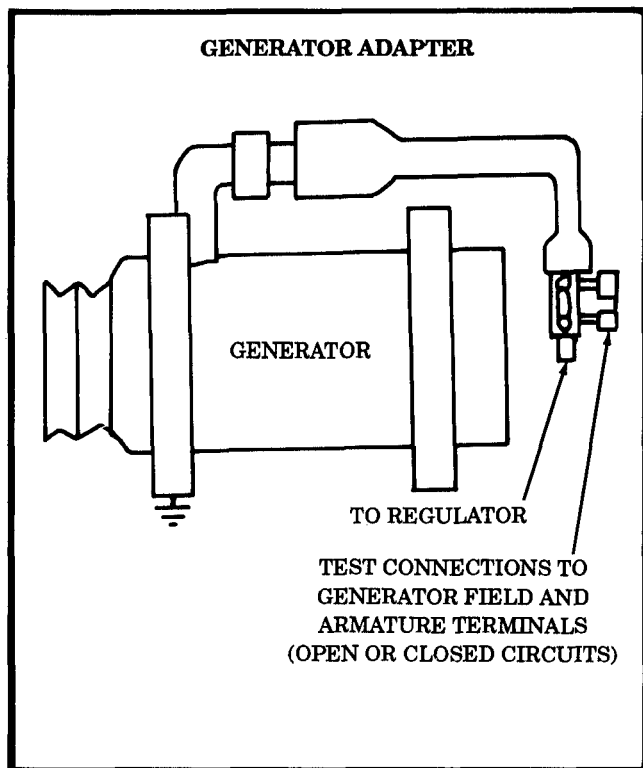



Table 2-11. STE/ICE No-Go Chain Tests (Contd).



**10** **INSTALL GENERATOR AND REGULATOR ADAPTERS:**  
(Part of Adapter Set, Engine Electrical, NSN 4910-00-348-7600)

- Disconnect generator cable at generator, and plug generator adapter into socket.
- Reconnect generator cable to free end of generator adapter.
- Disconnect regulator cable at regulator, and plug regulator adapter into socket.
- Reconnect regulator cable to free end of regulator adapter.

**11** **CONNECT TEST PROBE CABLE/DO OFFSET:**

- Connect P1 of test probe cable W2 to J4 in VTM.
- Short red and black clip leads together.

• Proceed to next page.

Table 2-11. STE/ICE No-Go Chain Tests (Contd).

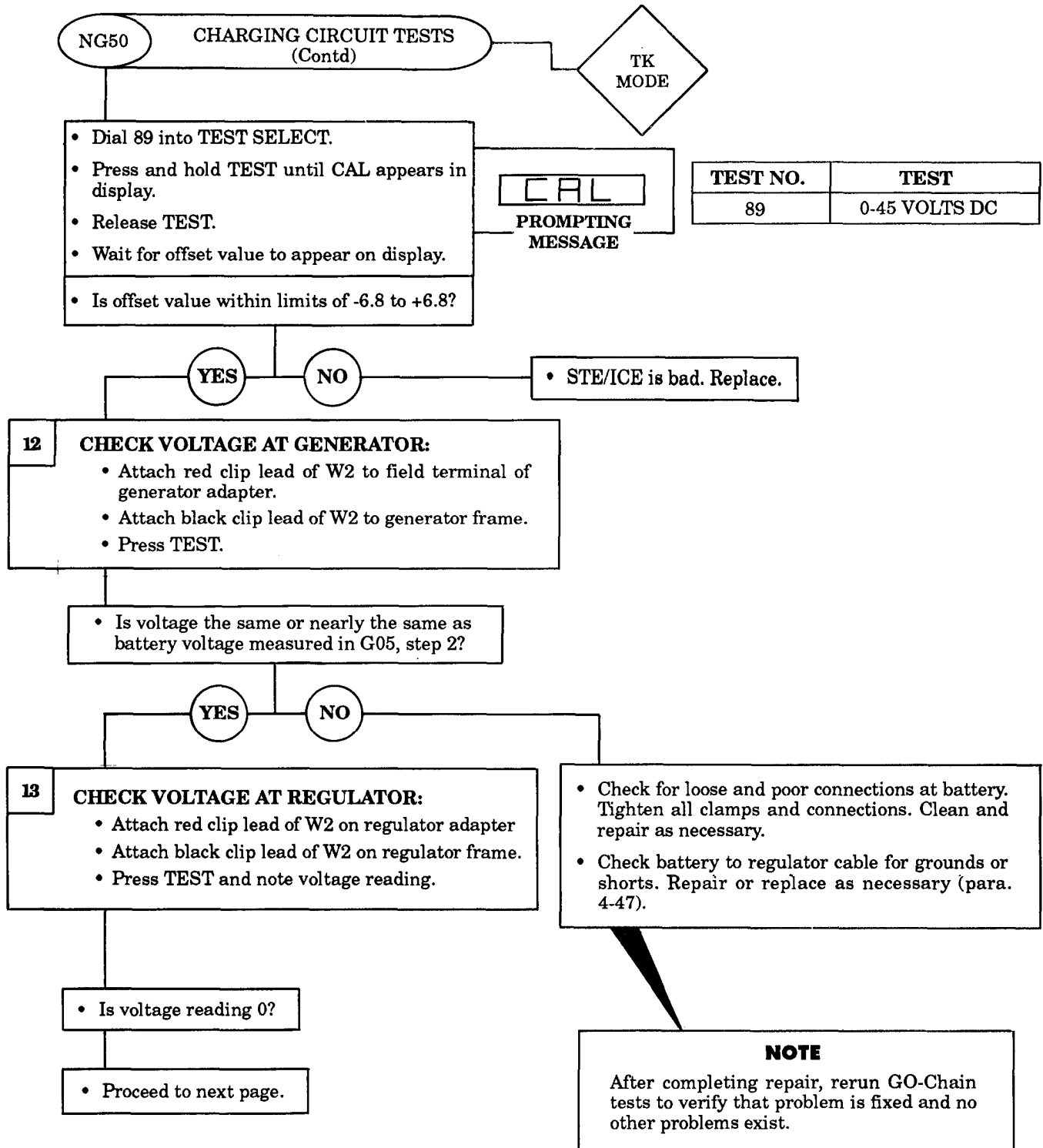

Table 2-11. STE/ICE No-Go Chain Tests (Contd).

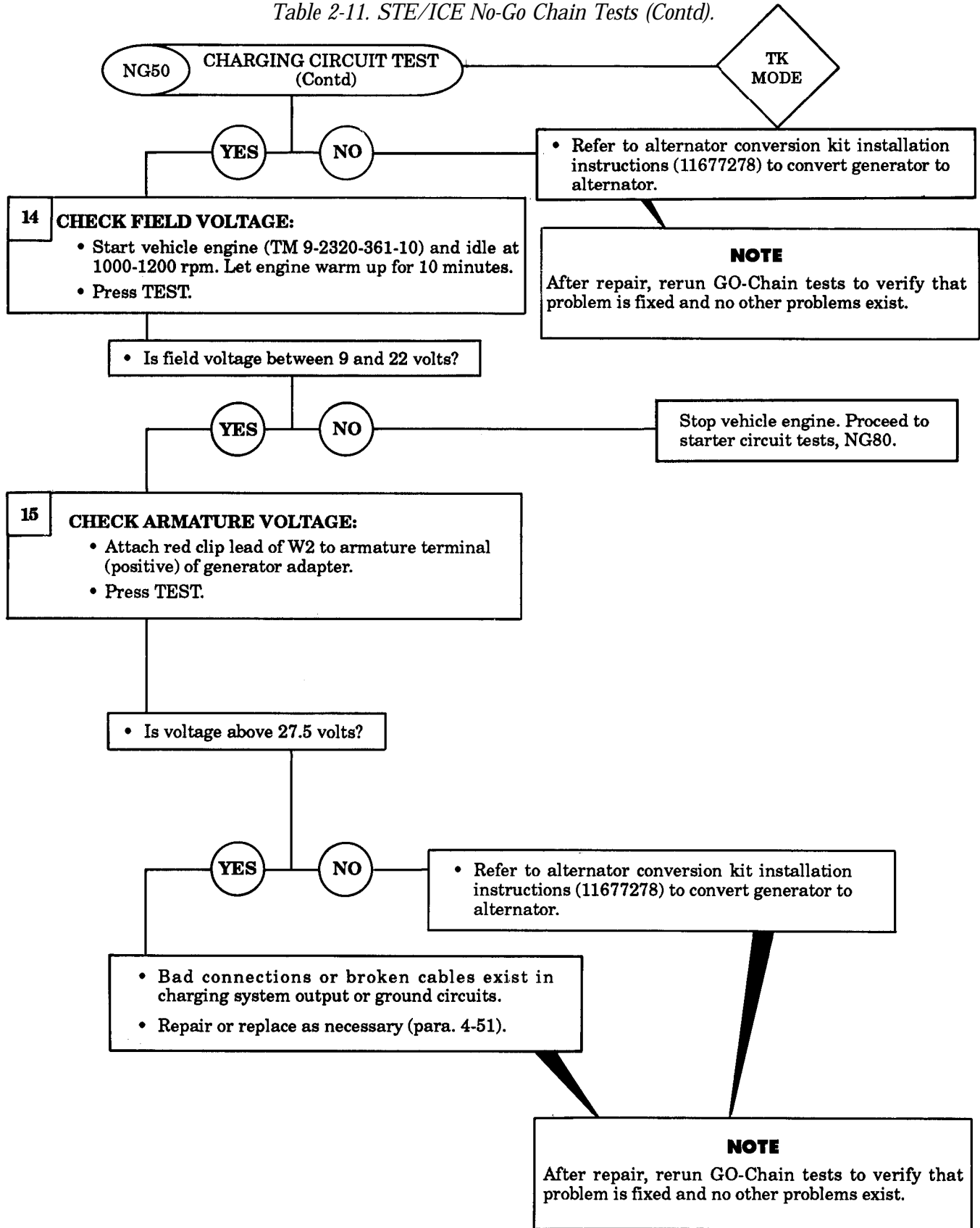
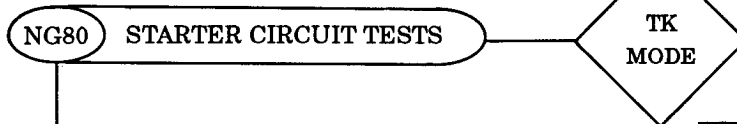
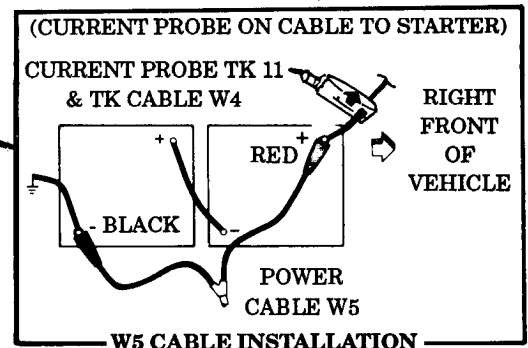

Table 2-11. STE/ICE No-Go Chain Tests (Contd).

**NOTE**  
Test G01, VTM Connections and Checkout, must be performed before running any other STE/ICE test.



**NOTE**  
While cranking engine with bad or discharged batteries, it is possible for VTM to lose power and come on again after cranking has stopped, displaying four dashes. If this occurs, clean battery posts and clamps and try again. If VTM still loses power, connect VTM power cable to good batteries in another vehicle and perform following tests using test probe cable W2.



**1 DO CURRENT PROBE OFFSET:**

- Connect cable W5 to batteries.
- Turn off all vehicle electrical power.
- Dial 74 into TEST SELECT.
- Press and hold TEST until CAL message appears on display.
- Release TEST.
- Wait for offset value to appear.

• Is offset value within limits of -225 to +225?

CAL

PROMPTING MESSAGE

TEST NO.	TEST
74	STARTER CIRCUIT RESISTANCE

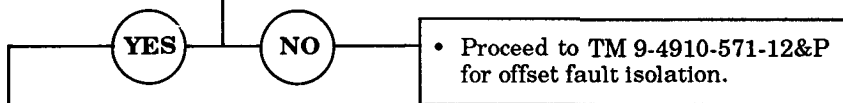

**2 CHECK STARTER CIRCUIT RESISTANCE:**

- Shut off fuel.
- Press TEST.
- When GO appears, attempt to crank engine.
- Stop cranking engine when VTM displays OFF or an error message.

• Is a number displayed?

GO

OFF

PROMPTING MESSAGE

• Proceed to next page.

Table 2-11. STE/ICE No-Go Chain Tests (Contd).

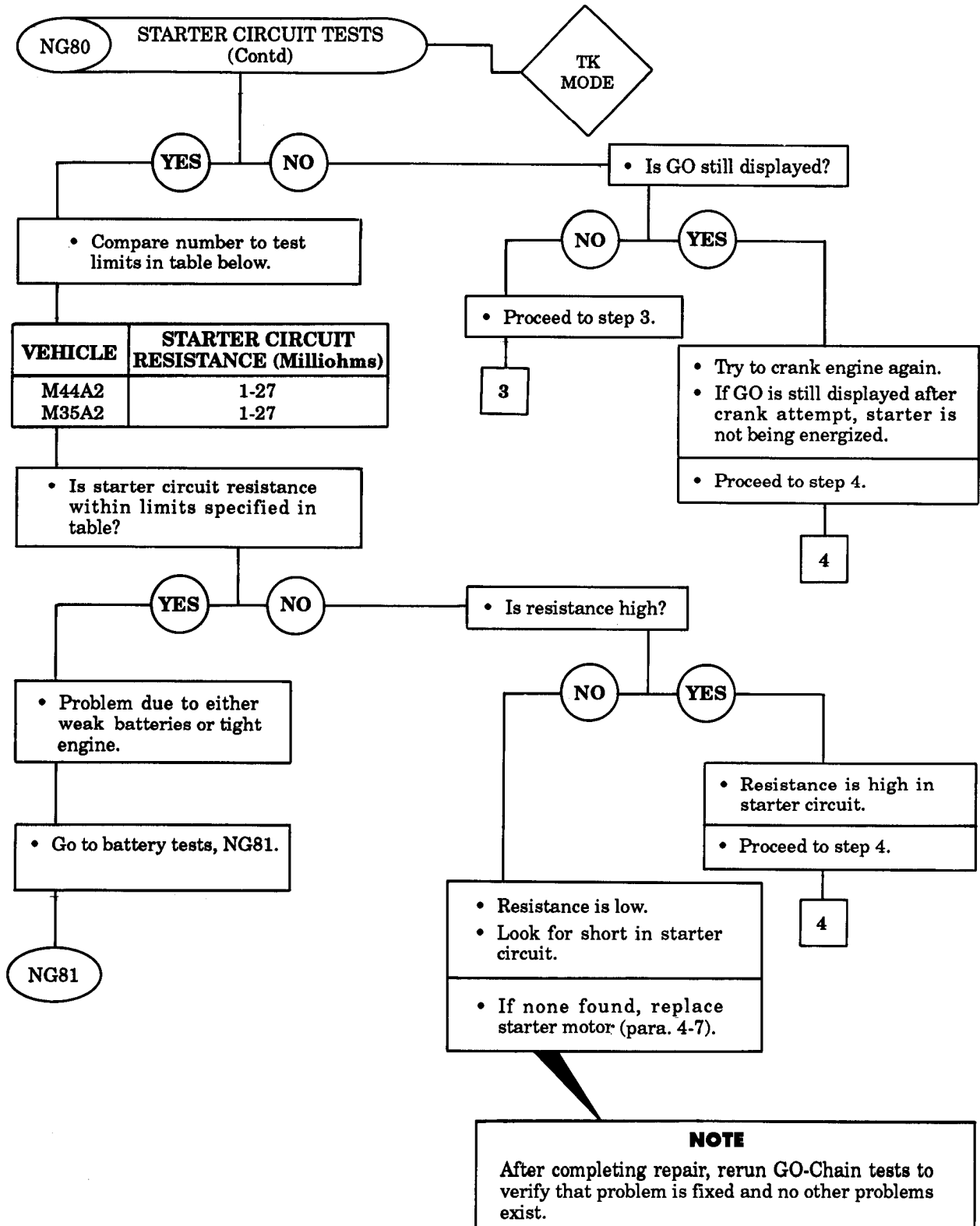

Table 2-11. STE/ICE No-Go Chain Tests (Contd).

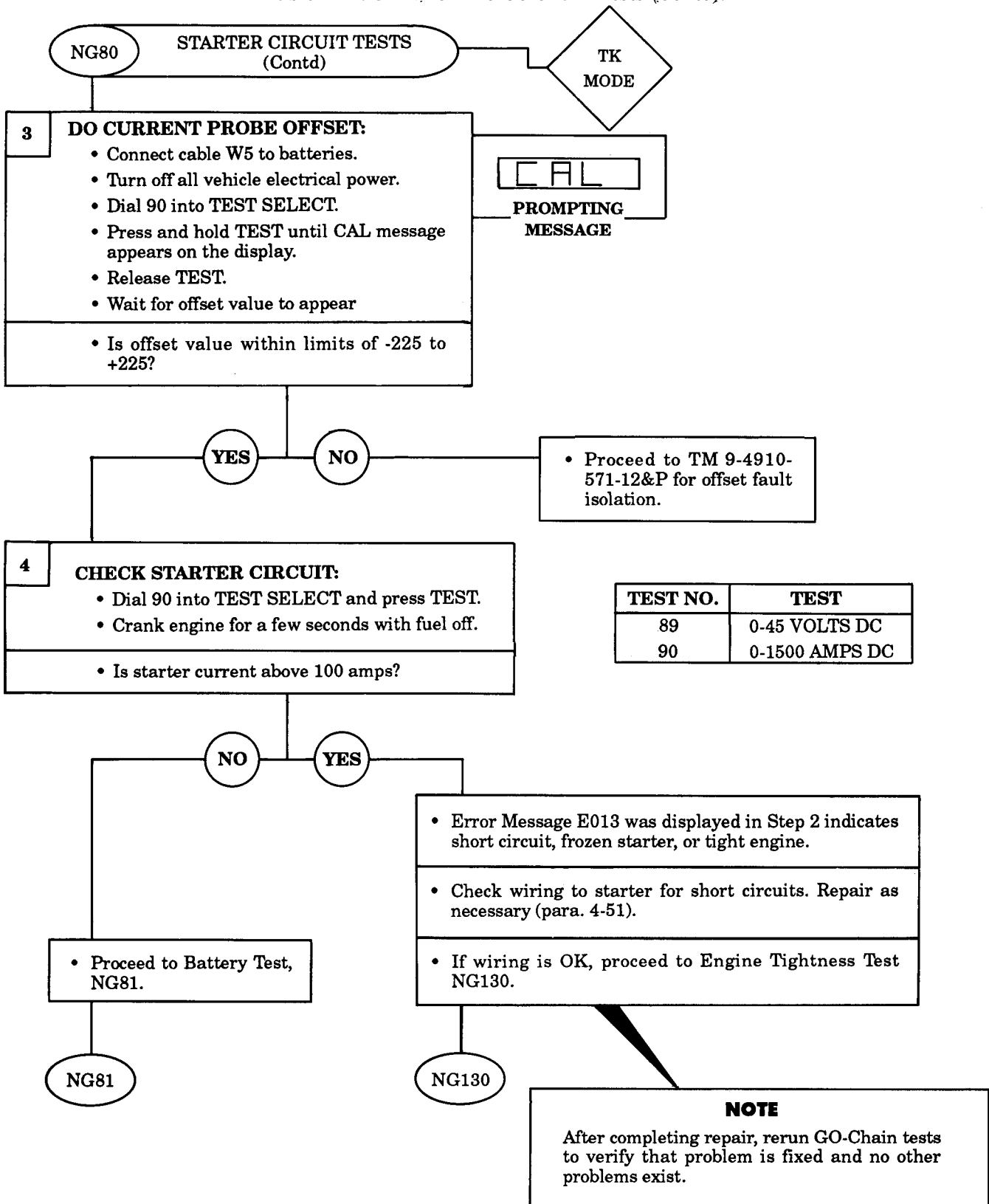

Table 2-11. STE/ICE No-Go Chain Tests (Contd).

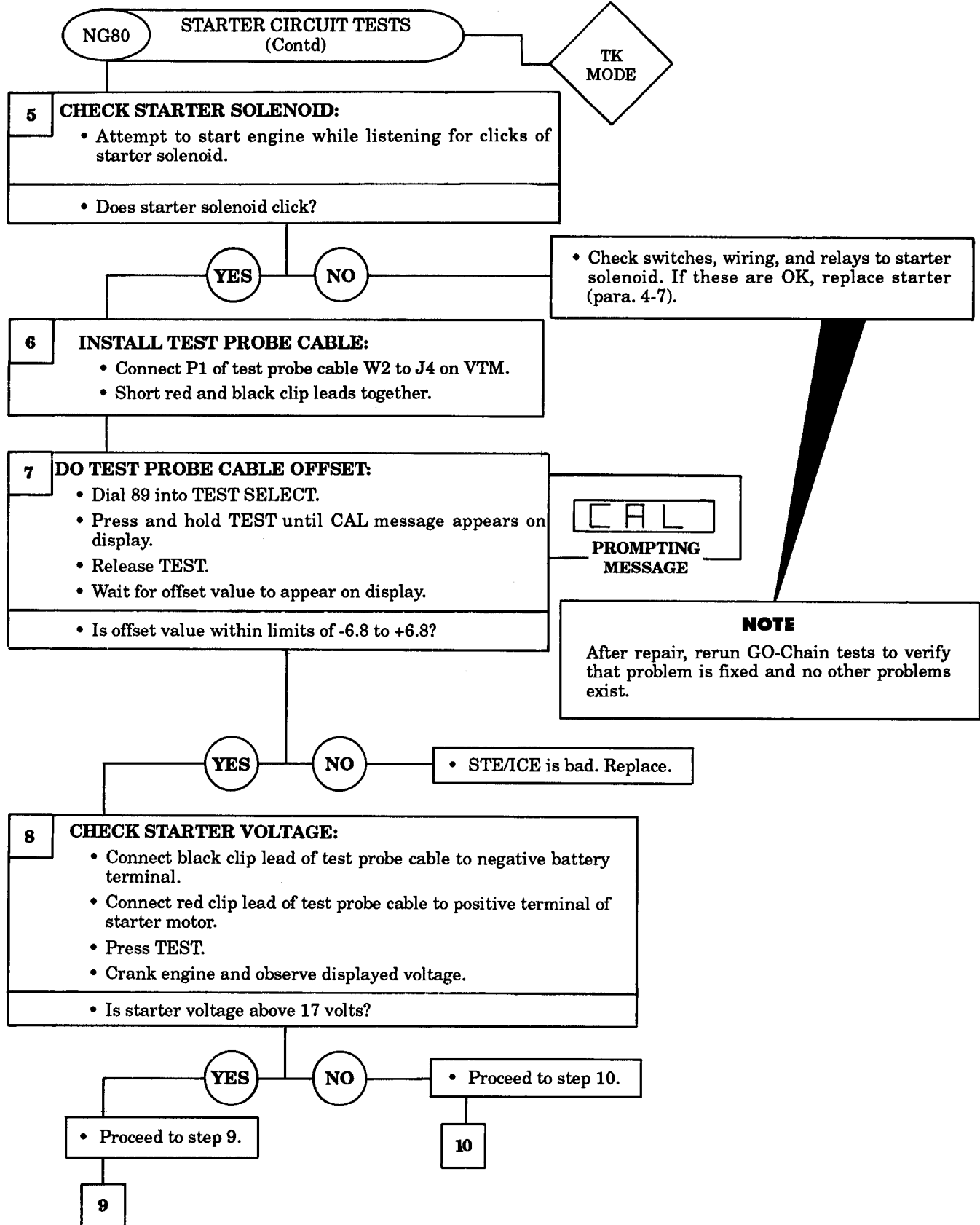
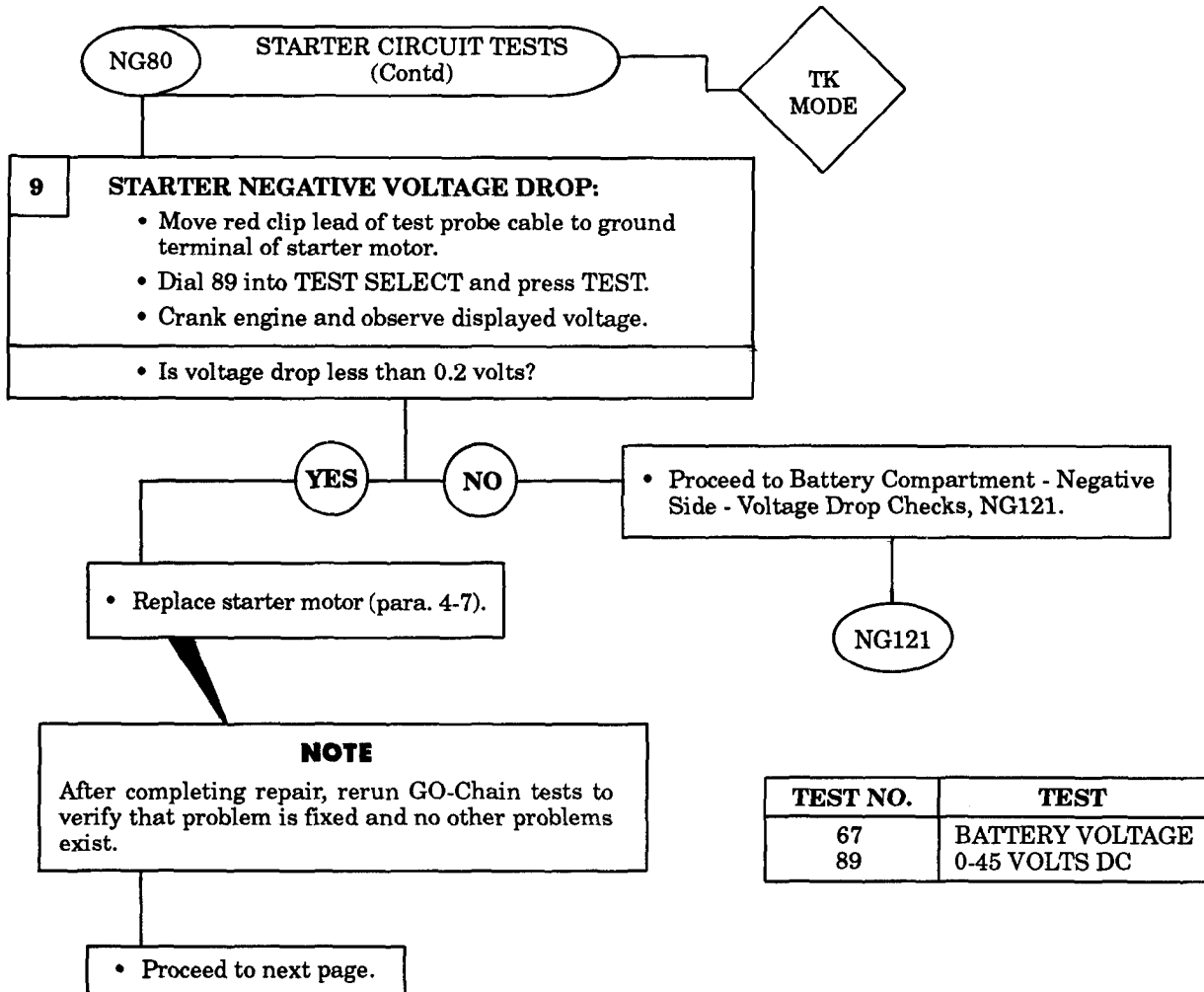

Table 2-11. STE/ICE No-Go Chain Tests (Contd).



TEST NO.	TEST
67	BATTERY VOLTAGE
89	0-45 VOLTS DC



Table 2-11. STE/ICE No-Go Chain Tests (Contd).

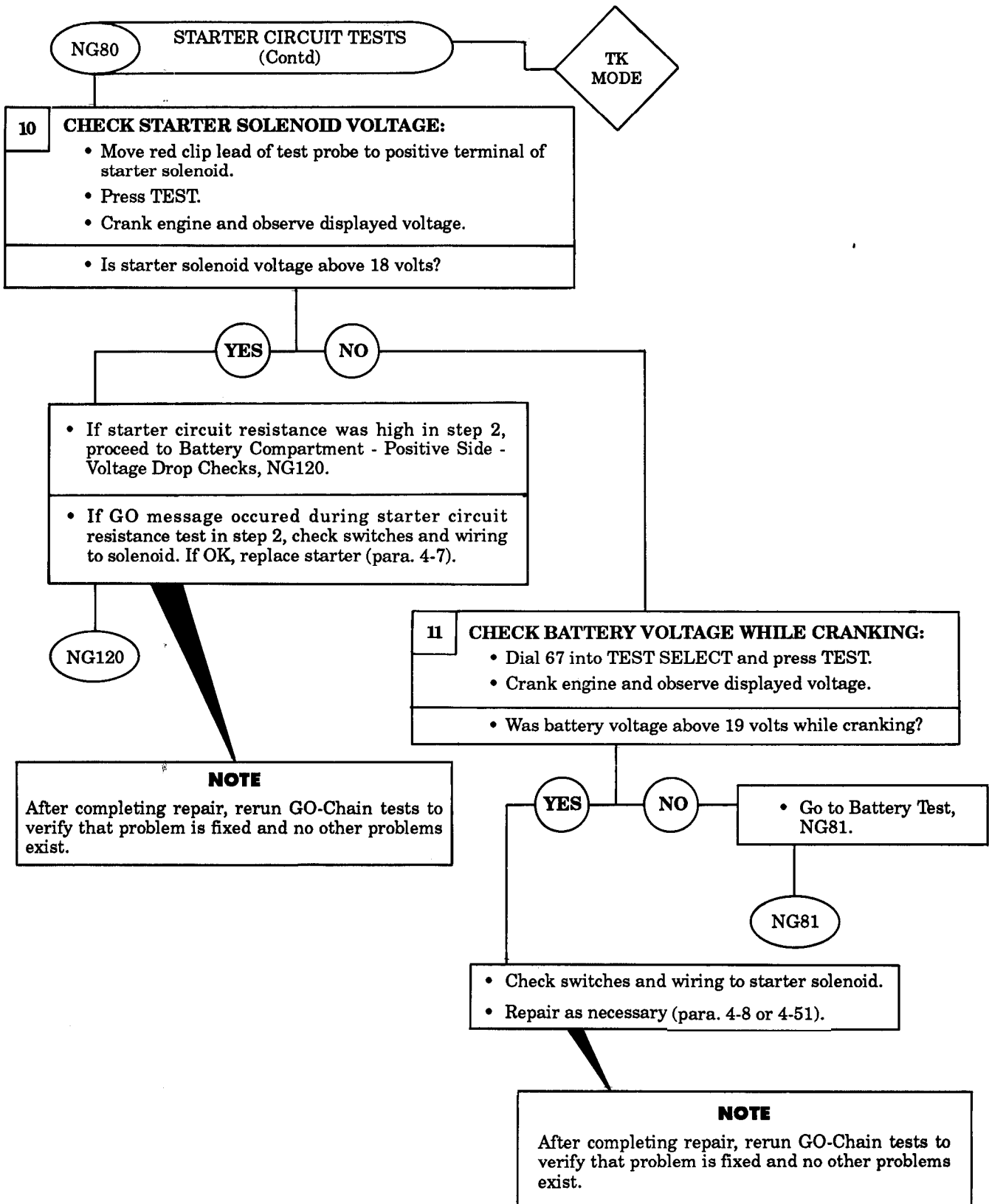

Table 2-11. STE/ICE No-Go Chain Tests (Contd).

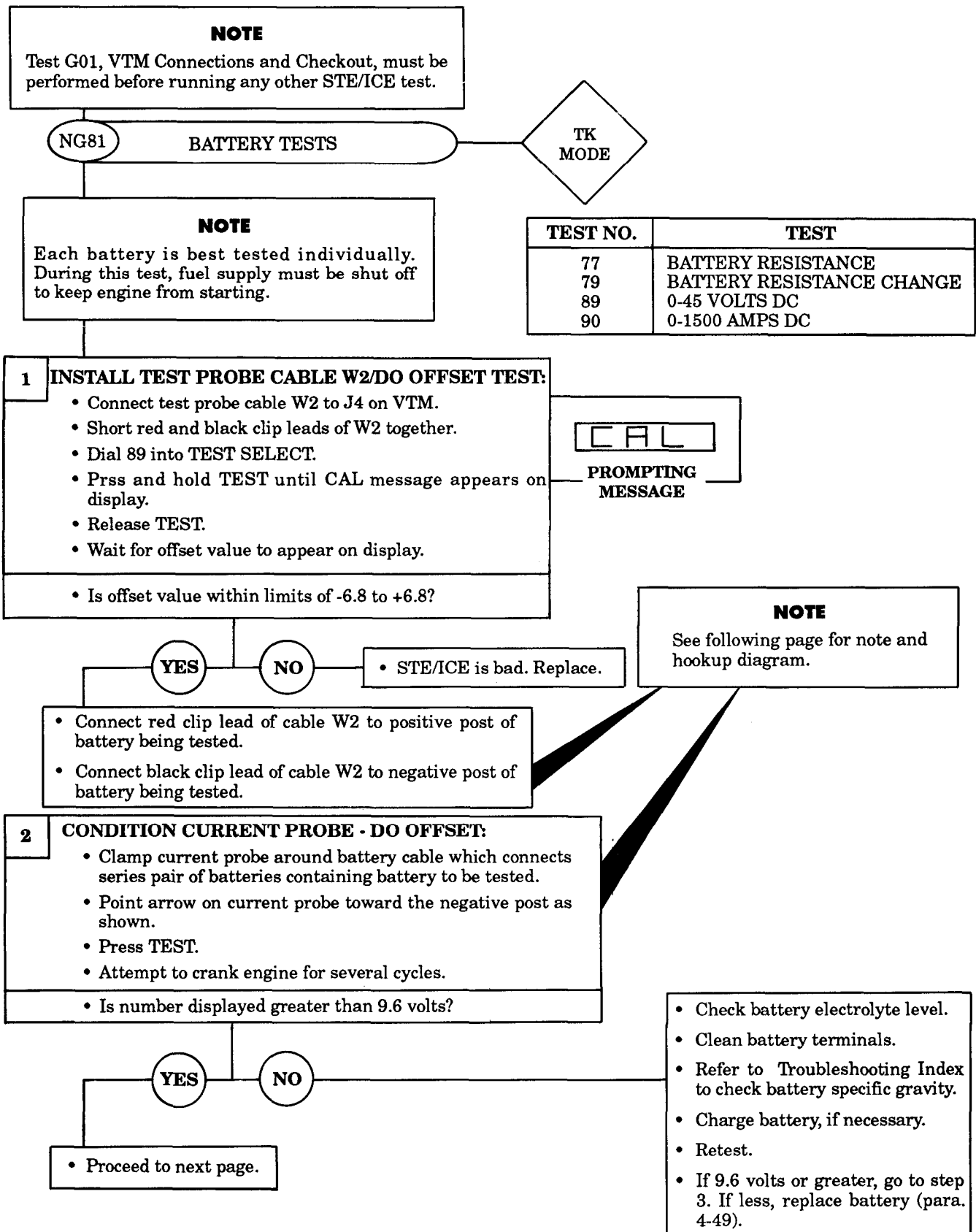
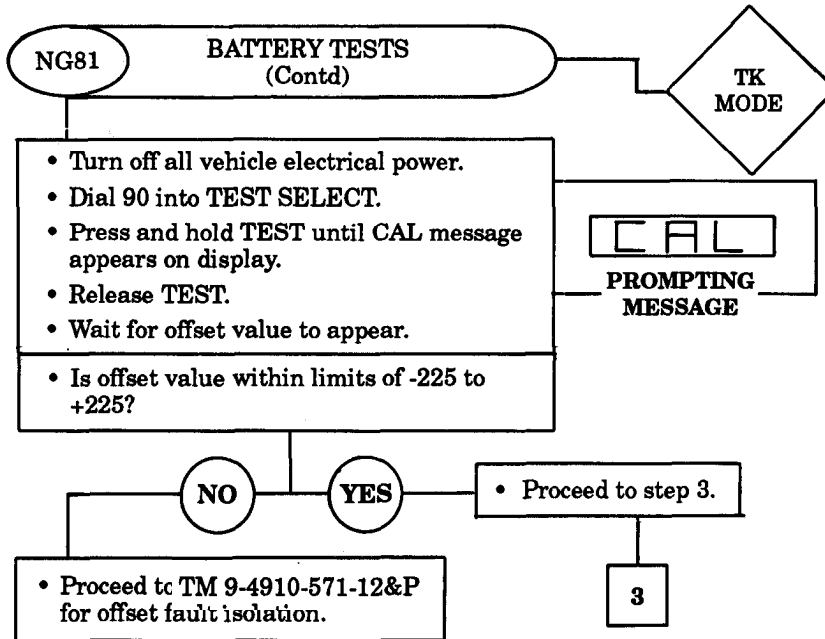

Table 2-11. STE/ICE No-Go Chain Tests (Contd).



**TEST PROCEDURE**

1. Test each battery of a series pair, then proceed to batteries of next series pair.
2. To find series pairs of batteries, find pairs for which the negative terminal of one battery is connected by a cable to the positive terminal of another battery. This makes the two batteries a series pair. For example, in figure below, batteries A and B are a series pair, and batteries C and D are also a series pair.
3. To test battery A or B, clamp current probe around cable connecting battery A and battery B. Point arrow on current probe in direction of negative post connected to the cable.
4. The test probe cable W2 is first connected to battery A for testing battery A.
5. The test probe cable W2 is then connected to battery B for testing battery B. (Current probe in same place as for testing battery A).
6. To test battery C or D, clamp current probe around cable connecting battery C and battery D. Point arrow on current probe in direction of negative post connected to cable.
7. Connect test probe cable W2 to battery C to test battery C.
8. Connect test probe cable W2 to battery D to test battery D.

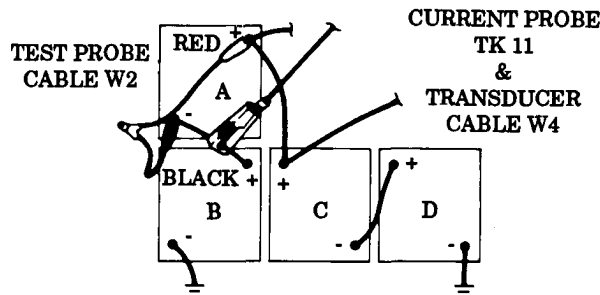

Table 2-11. STE/ICE No-Go Chain Tests (Contd).

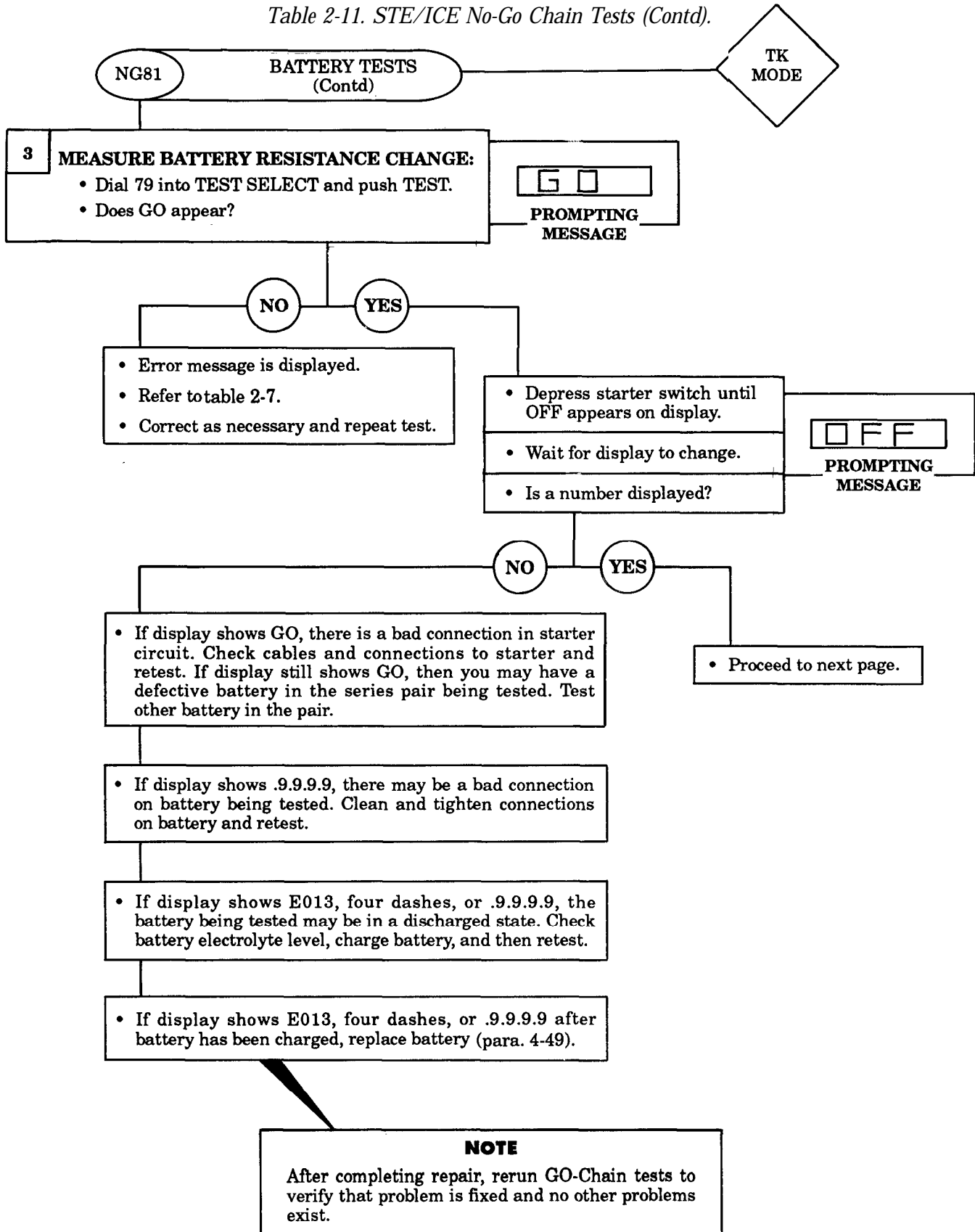

Table 2-11. STE/ICE No-Go Chain Tests (Contd).

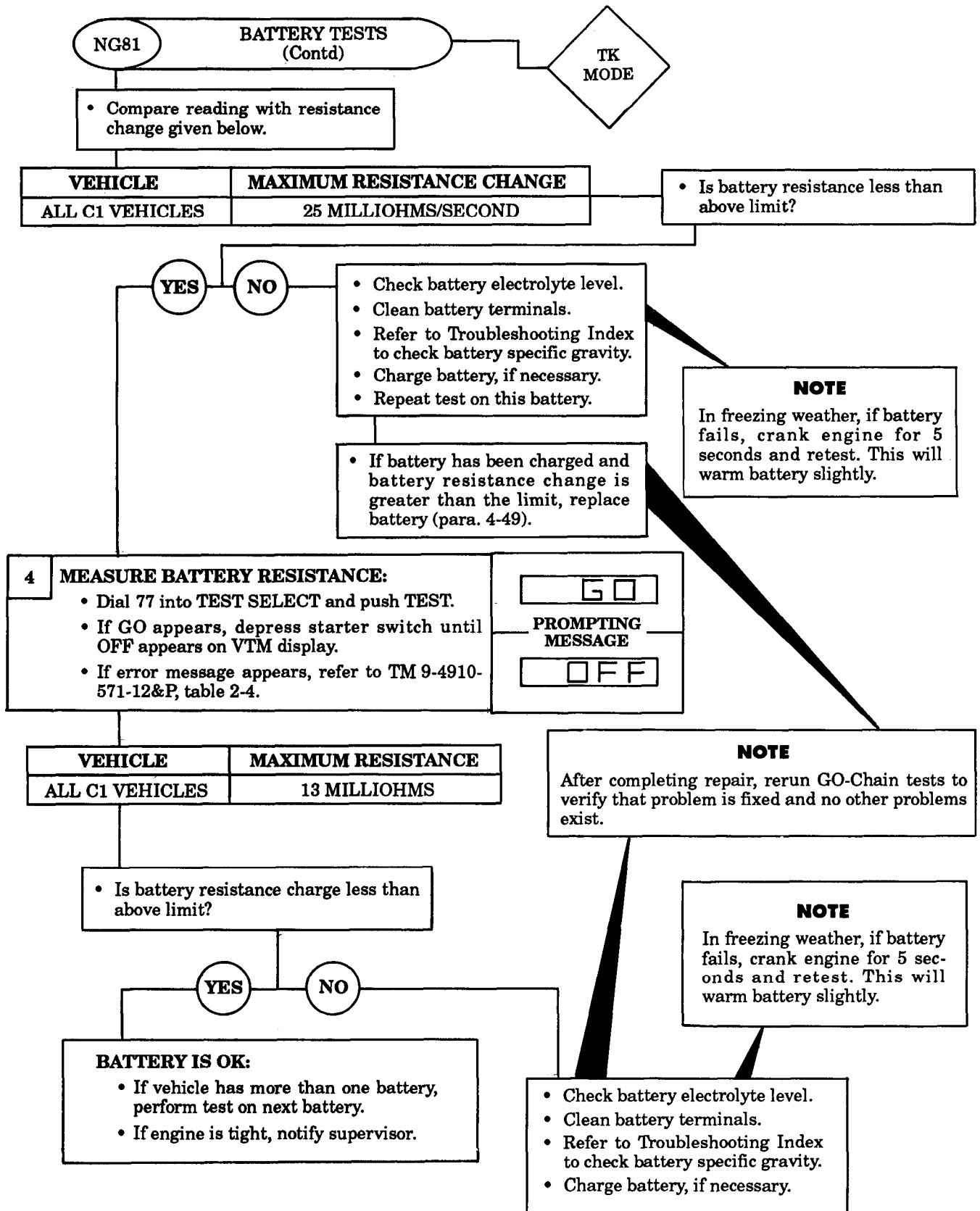

Table 2-11. STE/ICE No-Go Chain Tests (Contd).

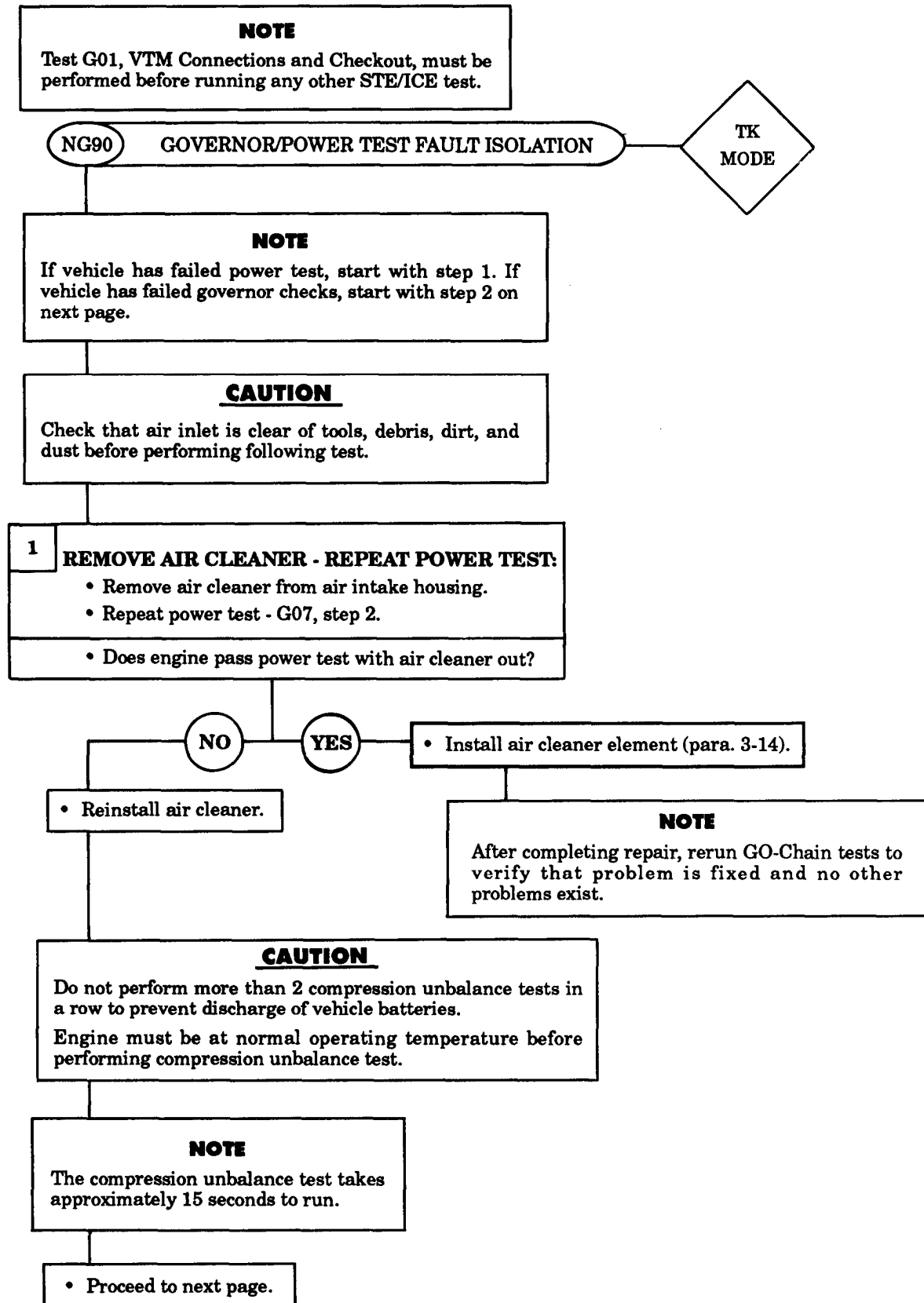

Table 2-11. STE/ICE No-Go Chain Tests (Contd).

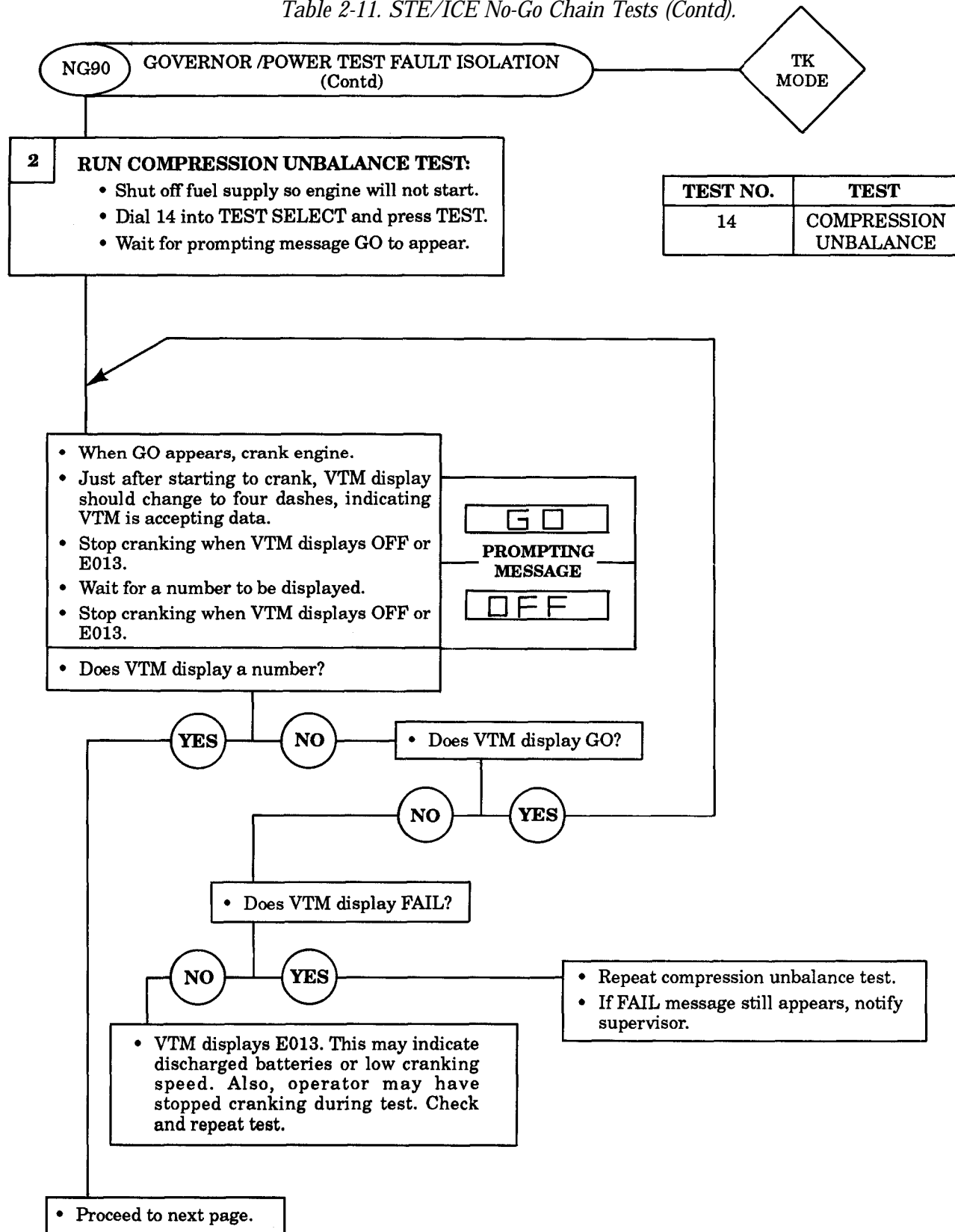

Table 2-11. STE/ICE No-Go Chain Tests (Contd).

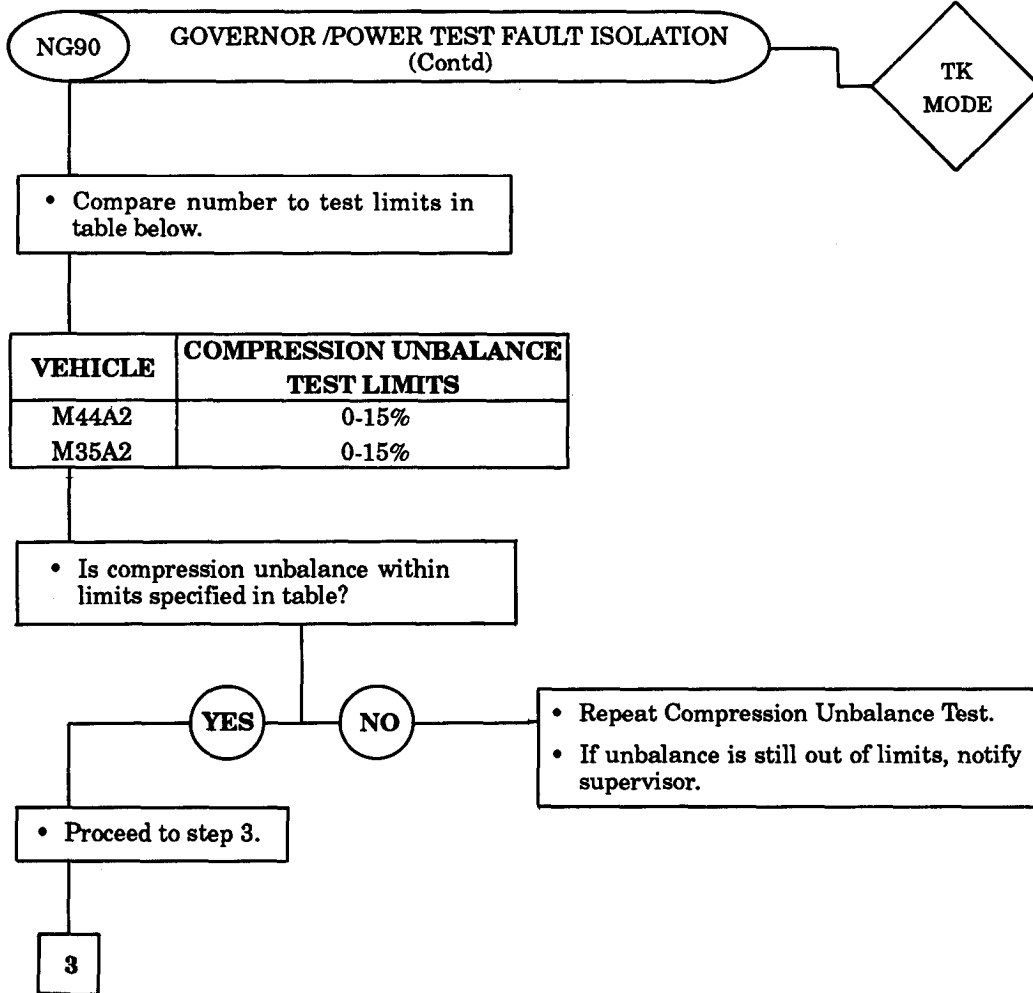
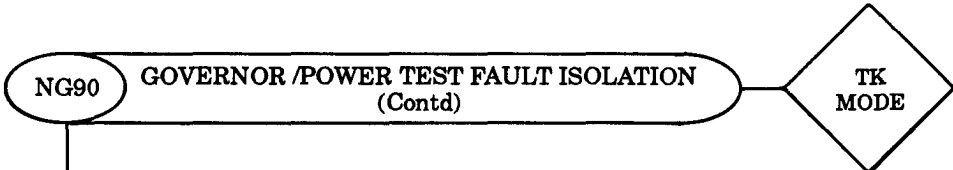
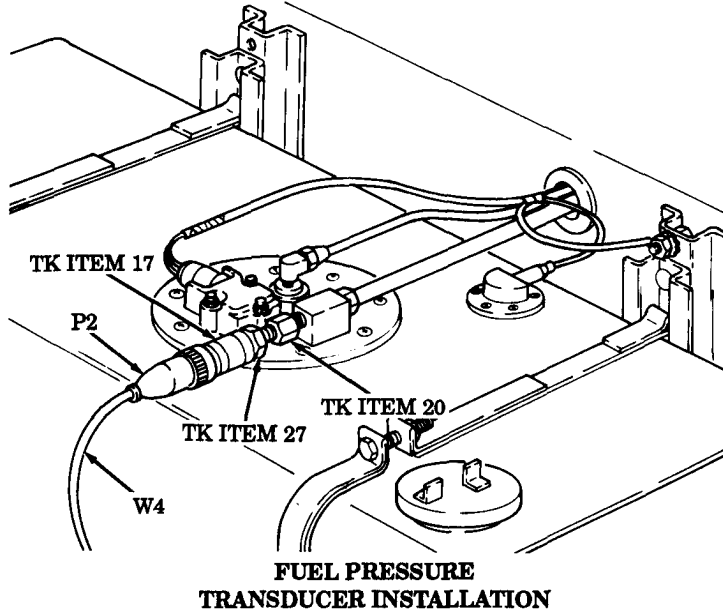



Table 2-11. STE/ICE No-Go Chain Tests (Contd).



**3** **INSTALL TRANSDUCER:**

- Install pressure transducer TK Item 17 (Blue Stripe) in outlet side of secondary fuel filter.
- Connect P1 of transducer cable W4 to J2 on VTU.
- Connect P2 of transducer cable to connector on transducer.

- Dial 50 into TEST SELECT and press TEST.
- Press and hold TEST until CAL message appears on display.
- Release TEST.
- Wait for offset value to appear on display.



- Proceed to next page.

TEST NO.	TEST
50	0-1000 PSIG, PRESSURE

Table 2-11. STE/ICE No-Go Chain Tests (Contd).

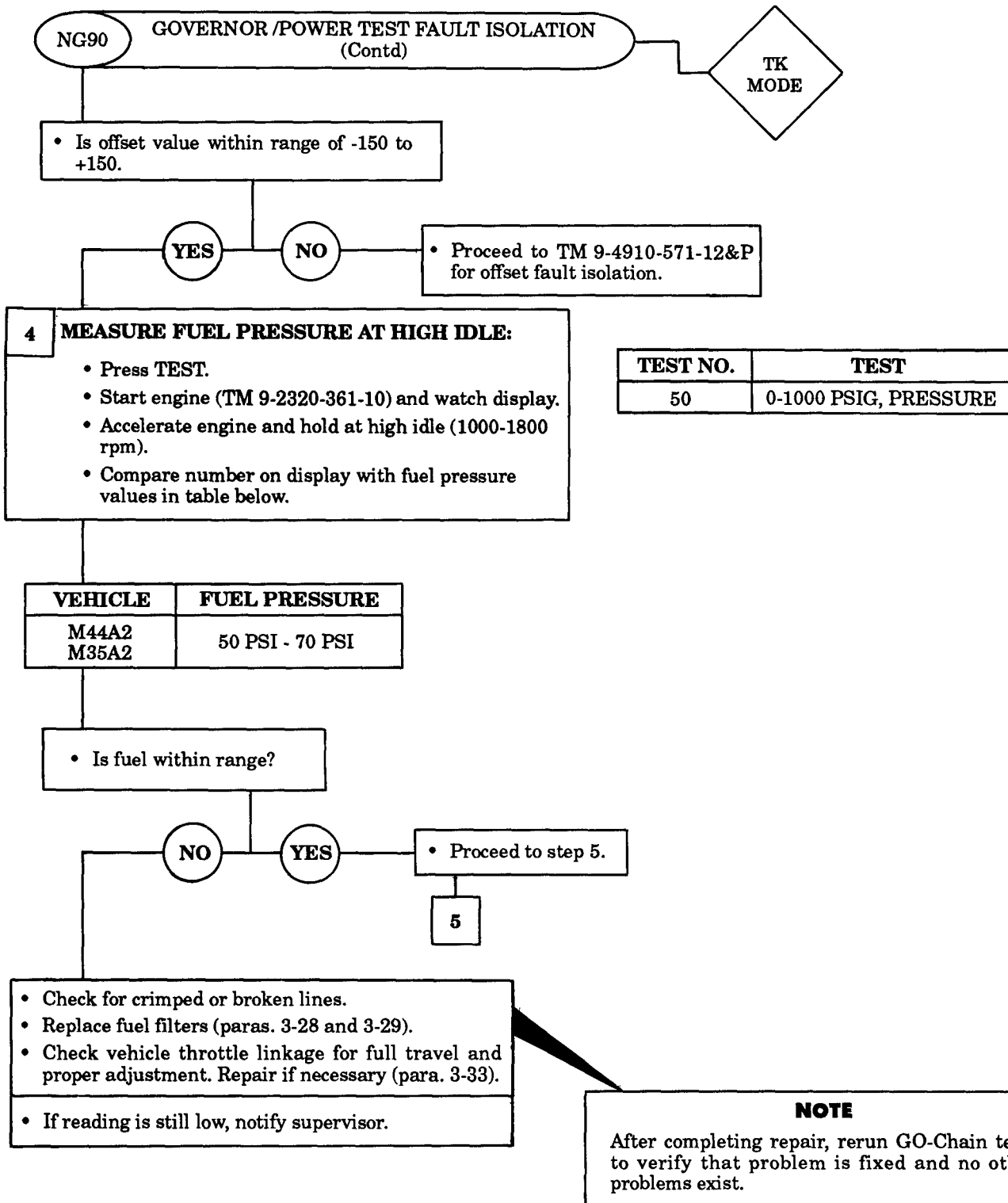

Table 2-11. STE/ICE No-Go Chain Tests (Contd).

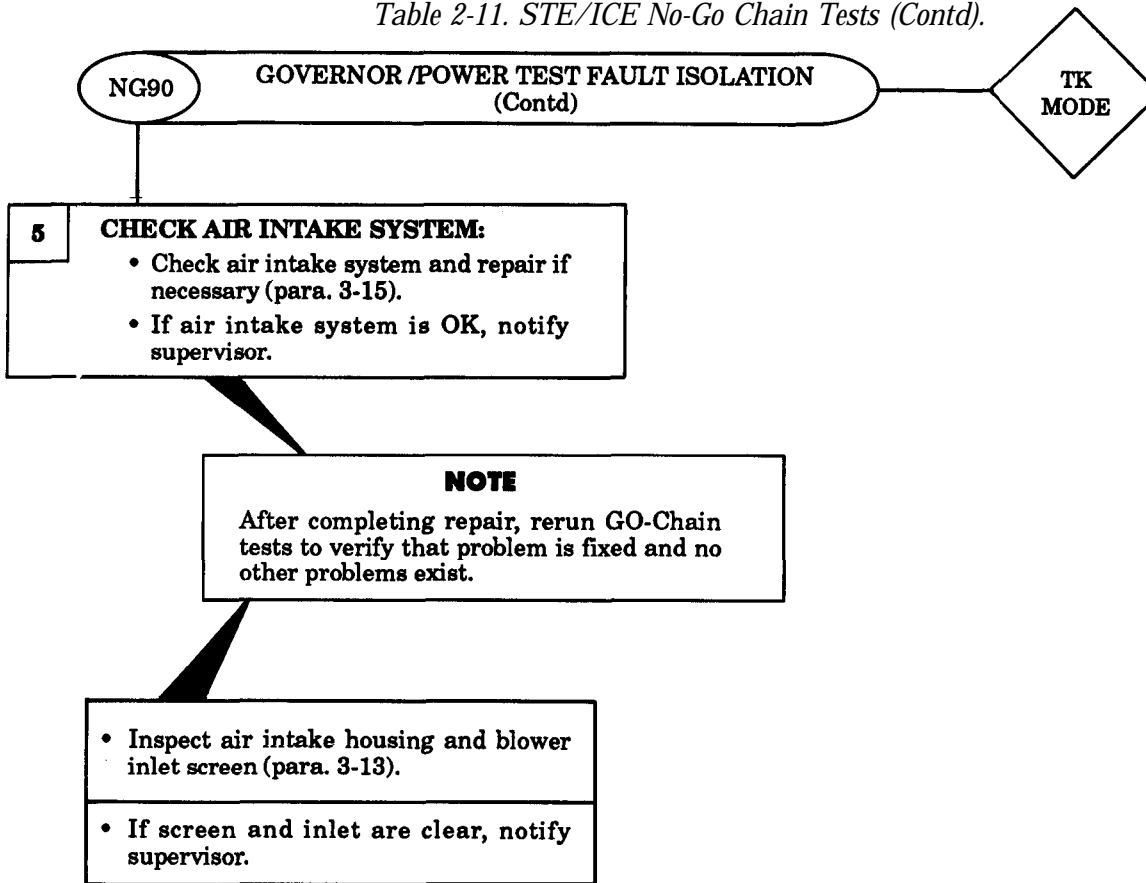

Table 2-11. STE/ICE No-Go Chain Tests (Contd).

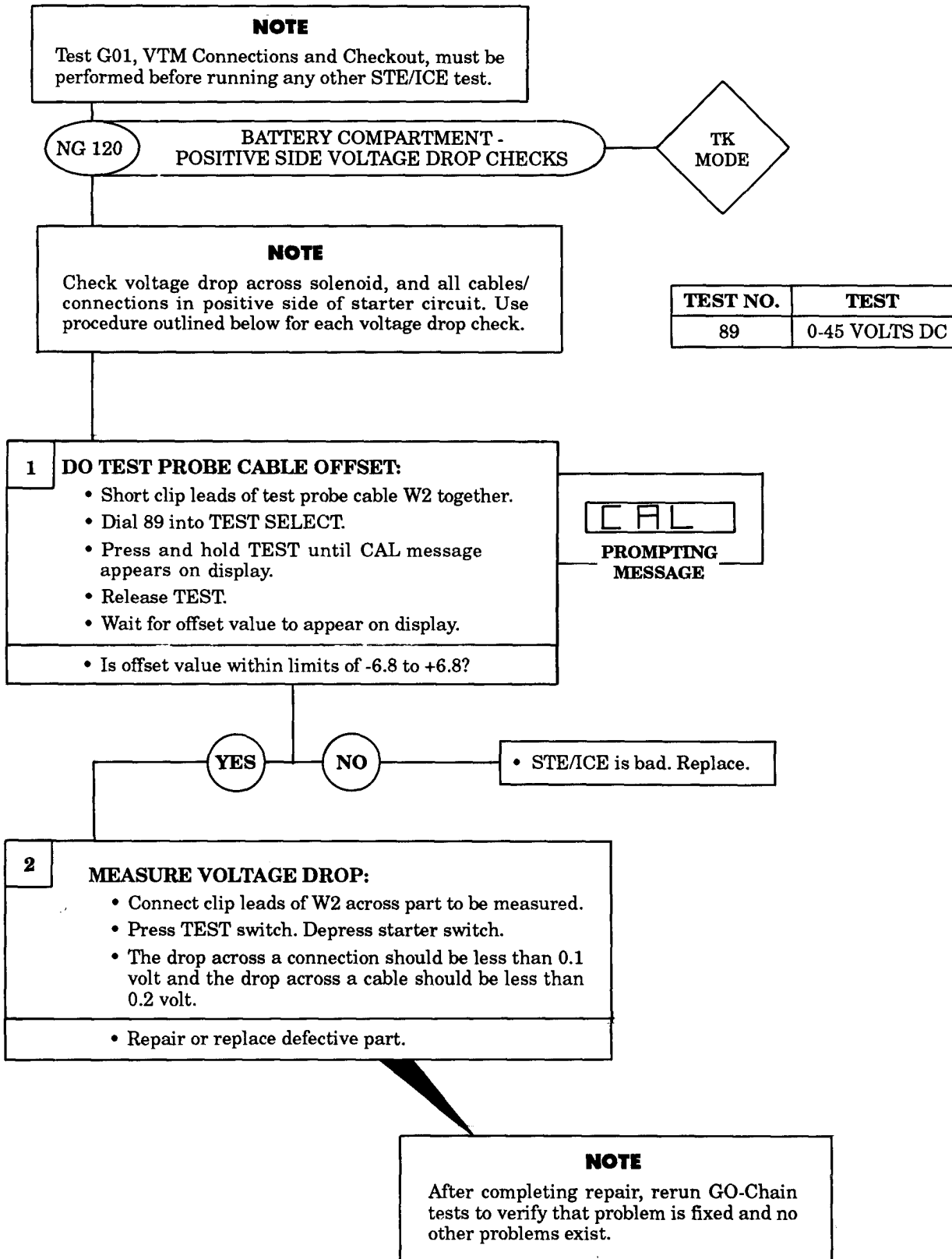

Table 2-11. STE/ICE No-Go Chain Tests (Contd).

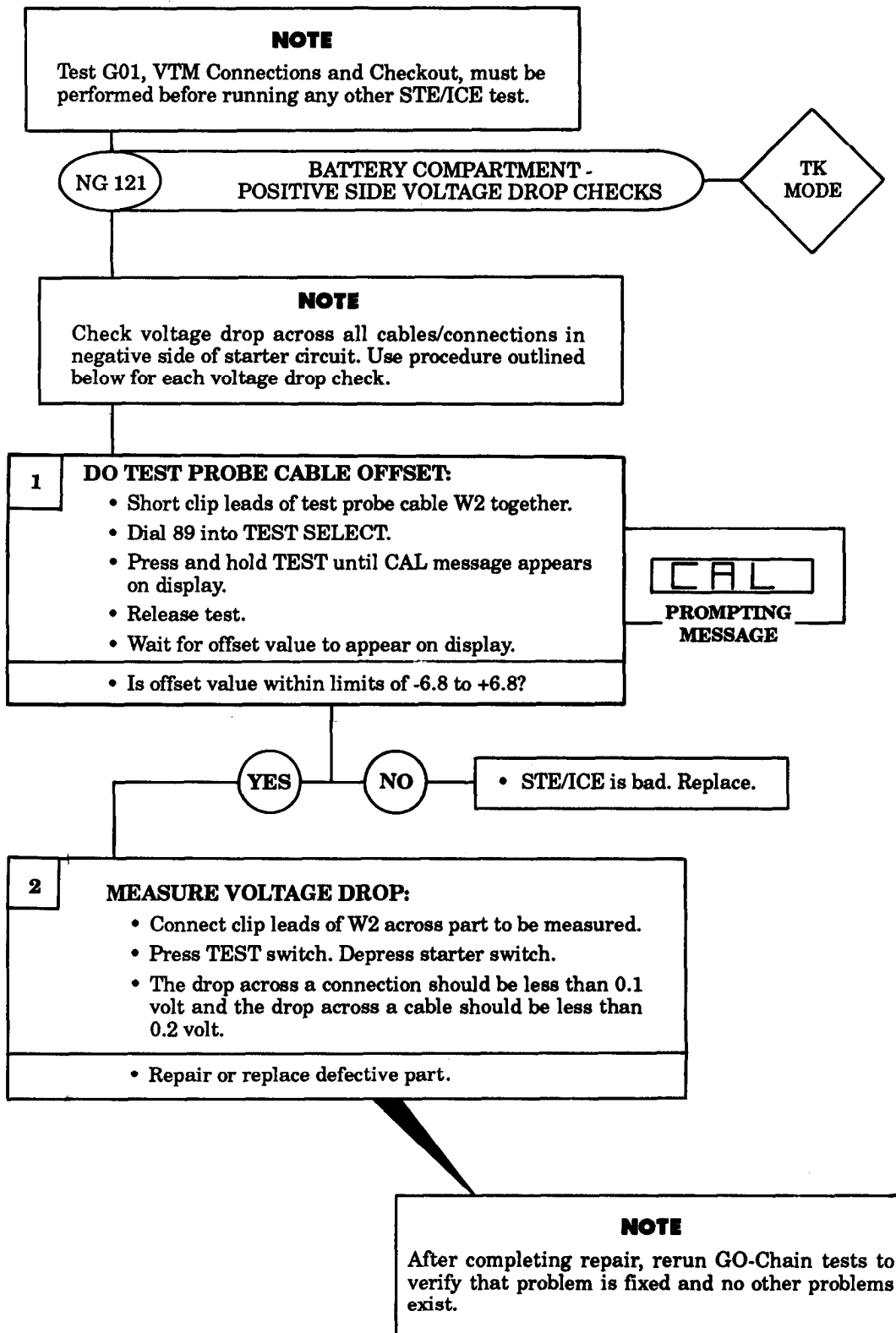
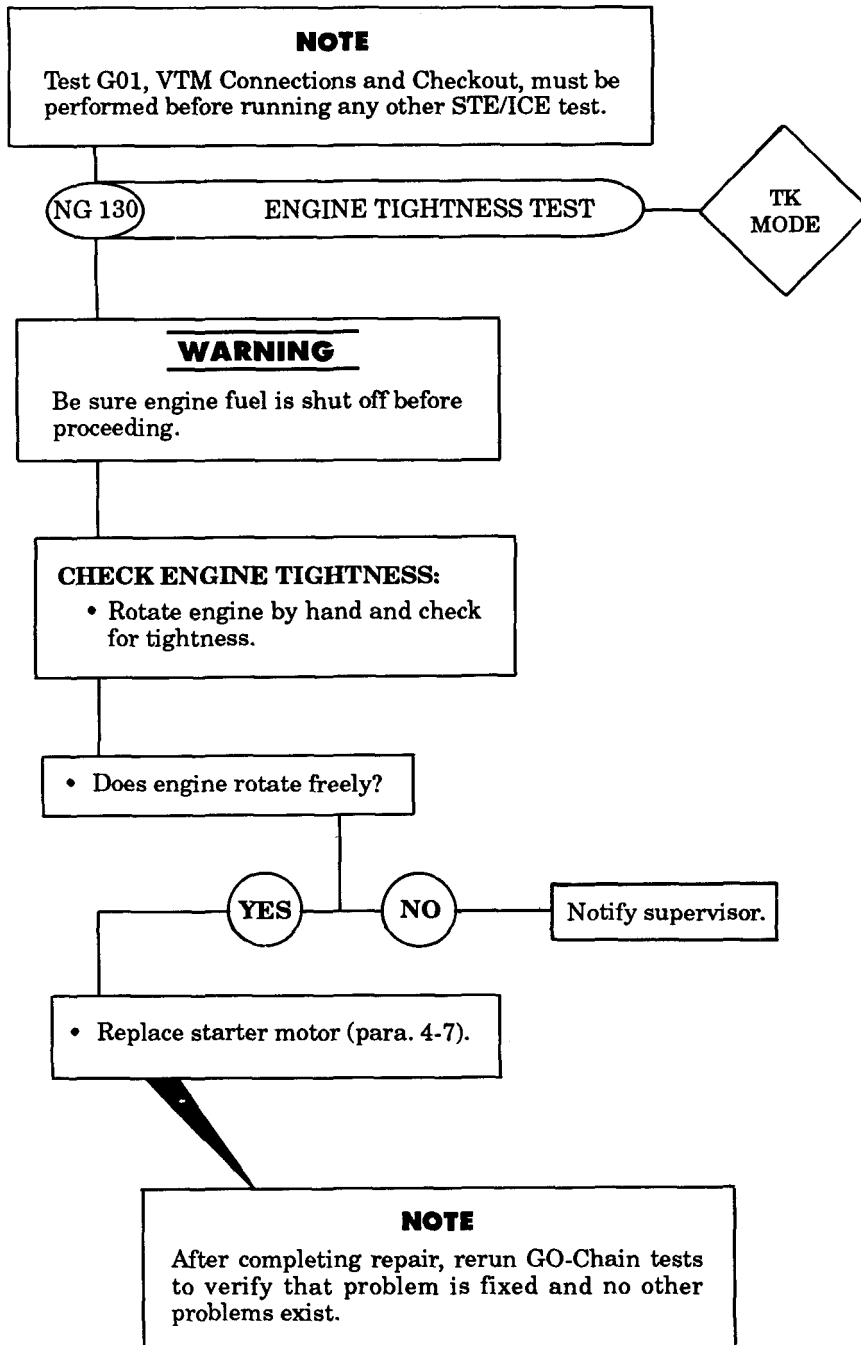

Table 2-11. STE/ICE No-Go Chain Tests (Contd).





**CHAPTER 3**

**ENGINE AND CLUTCH SYSTEMS MAINTENANCE**

Section I.	Engine Maintenance (page 3-1)
Section II.	Engine Lubrication System Maintenance (page 3-6)
Section III.	Clutch System Maintenance (page 3-14)
Section IV.	Air Intake System Maintenance (page 3-20)
Section V.	Turbocharger Maintenance (page 3-28)
Section VI.	Fuel System Maintenance (page 3-31)
Section VII.	Accelerator System Maintenance (page 3-70)
Section VIII.	Exhaust System Maintenance (page 3-82)
Section IX.	Cooling System Maintenance (page 3-92)

**Section I. ENGINE MAINTENANCE**

**3-1. ENGINE MAINTENANCE INDEX**

PARA. NO.	TITLE	PAGE NO.
3-2.	Engine Front Mount Pad Replacement	3-1
3-3.	Engine Rear Mount Pad Replacement	3-4

**3-2. ENGINE FRONT MOUNT PAD REPLACEMENT**

**This task covers:**

- a. Front Mount Pad Removal**
- b. Support Plate Removal**

- c. Support Plate Installation**
- d. Front Mount Pad Installation**

**INITIAL SETUP:**

**APPLICABLE MODELS**

All

**MATERIALS/PARTS**

Four locknuts  
Lockwasher

**REFERENCES (TM)**

TM 9-2320-361-10  
TM 9-2320-361-20P

**EQUIPMENT CONDITION**

- Parking brake set (TM 9-2320-361-10).
- Hood raised and secured (TM 9-2320-361-10).
- Brush guard removed (para. 10-8).
- Front bumper removed (paras. 10-9 and 10-10).

**GENERAL SAFETY INSTRUCTIONS**

- Place support under radiator before removing support plate.
- Do not put fingers between frame and engine support.



## 3-2. ENGINE FRONT MOUNT PAD REPLACEMENT (Contd)

### a. Front Mount Pad Removal

1. Remove two locknuts (13), washers (12), springs (11), and washers (10) from studs (2). Discard locknuts (13).
2. Remove two locknuts (16) and washers (15) from screws (8). Discard locknuts (16).
3. Remove nut (20), screw (17), lockwasher (19), washer (18), and ground strap (23) from front crossmember (6). Discard lockwasher (19).
4. Remove two nuts (4), screws (14), clamps (5), and fuel line (7) from crossmember (6).
5. Push two screws (8) up through crossmember (6), lower front pads (24), and upper front pads (25) as far as possible.

### **WARNING**

Do not put fingers between frame and engine support. Jack failure may result in injury to personnel.

6. Carefully lift engine and radiator (3), and remove two upper front pads (25) and lower front pads (24) from crossmember (6).

### b. Support Plate Removal

### **WARNING**

- Do not put fingers between frame and engine support. Jack failure may result in injury to personnel.
- Place support under radiator before removing support plate. Failure to do so may result in injury to personnel and damage to equipment.

1. Place support under radiator (3).
2. Remove six screws (21), washers (22), and support plate (9) from two engine supports (1) and studs (2).
3. Remove two screws (8) from support plate (9).

### c. Support Plate Installation

### **WARNING**

Do not put fingers between frame and engine support. Jack failure may result in injury to personnel.

1. Install two screws (8) on support plate (9).
2. Install support plate (9) on two studs (2) and engine supports (1) with six washers (22) and screws (21). Tighten screws (21) 25-27 lb-ft (34-37 N·m) and remove support from radiator (3).

### d. Front Mount Pad Installation

### **WARNING**

Do not put fingers between frame and engine support. Jack failure may result in injury to personnel.

1. Install two lower front pads (24) and upper front pads (25) on front crossmember (6).
2. Carefully lower engine and radiator (3) guiding two screws (8) through upper and lower front pads (25) and (24) and crossmember (6).

### 3-2. ENGINE FRONT MOUNT PAD REPLACEMENT (Contd)

3. Install fuel line (7) on crossmember (6) with two clamps (5), screws (14), and nuts (4).
4. Install ground strap (23) on crossmember (6) with screw (17), washer (18), new lockwasher (19), and nut (20).
5. Install two washers (15) and new locknuts (16) on screws (8). Tighten locknuts (16) 65-70 lb-ft (88-95 N·m).
6. Install two washers (10), springs (11), washers (12), and new locknuts (13) on studs (2). Do not fully compress springs (11).

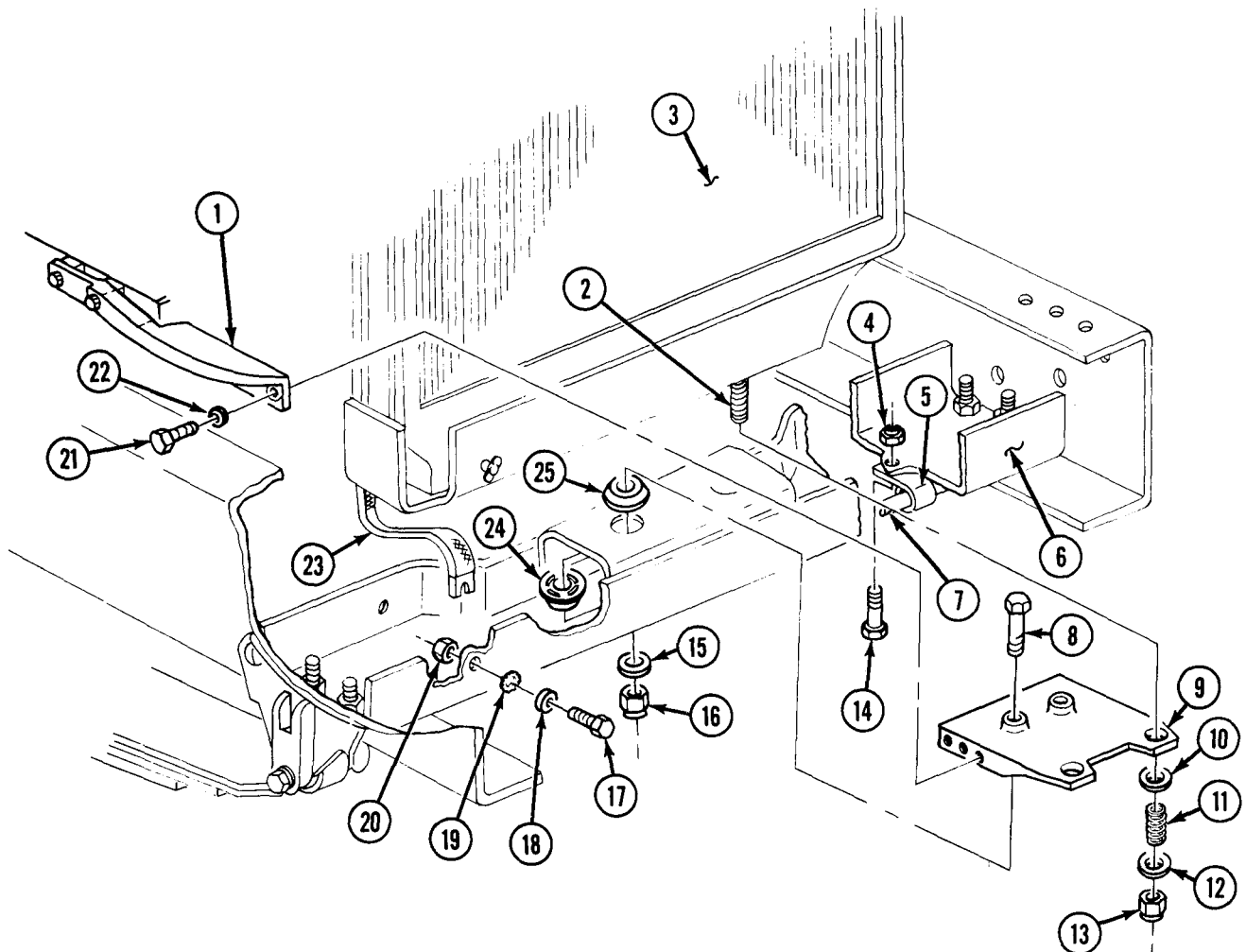

- FOLLOW-ON TASKS:**
- Install brush guard (para. 10-8).
  - Install front bumper (paras. 10-9 and 10-10).

### 3-3. ENGINE REAR MOUNT PAD REPLACEMENT

This task covers:

**a. Removal**

**b. Installation**

**INITIAL SETUP:**

APPLICABLE MODELS

All

MATERIALS/PARTS

Locknut

REFERENCES (TM)

TM 9-2320-361-10

TM 9-2320-361-20P

EQUIPMENT CONDITION

Parking brake set (TM 9-2320-361-10).

GENERAL SAFETY INSTRUCTIONS

Do not put fingers between frame and engine support.

**a. Removal**

**NOTE**

Perform step 1 for engine left rear mount.

1. Remove nut (1) and accelerator linkage (3) from throttle control lever (2).

**NOTE**

Right and left engine rear mounts are removed the same way. This procedure covers the right engine rear mount.

2. Remove locknut (10), washer (9), and lower rear engine pad (8) from frame (7). Discard locknut (10).
3. Position hydraulic jack (13) and wood blocks (14) under transmission (12) lifting point. Raise transmission (12) just enough to take weight off upper rear engine pad (11).

**WARNING**

Do not put fingers between frame and engine support. Jack failure may cause injury to personnel.

4. Remove screw (4), washer (5), and upper rear engine pad (11) from frame (7) and engine support (6).

**b. Installation**

1. Install upper rear engine pad (11) on frame (7) with washer (5) and screw (4).
2. Lower hydraulic jack (13) and remove jack (13) and wood blocks (14) from transmission (12).
3. Install lower rear engine pad (8) on frame (7) with washer (9) and new locknut (10). Tighten locknut (10) 65-70 lb-ft (88-95 N·m).

**NOTE**

Perform step 4 for engine left rear mount.

4. Install accelerator linkage (3) on throttle control lever (2) with nut (1).

3-3. ENGINE REAR MOUNT PAD REPLACEMENT (Contd)

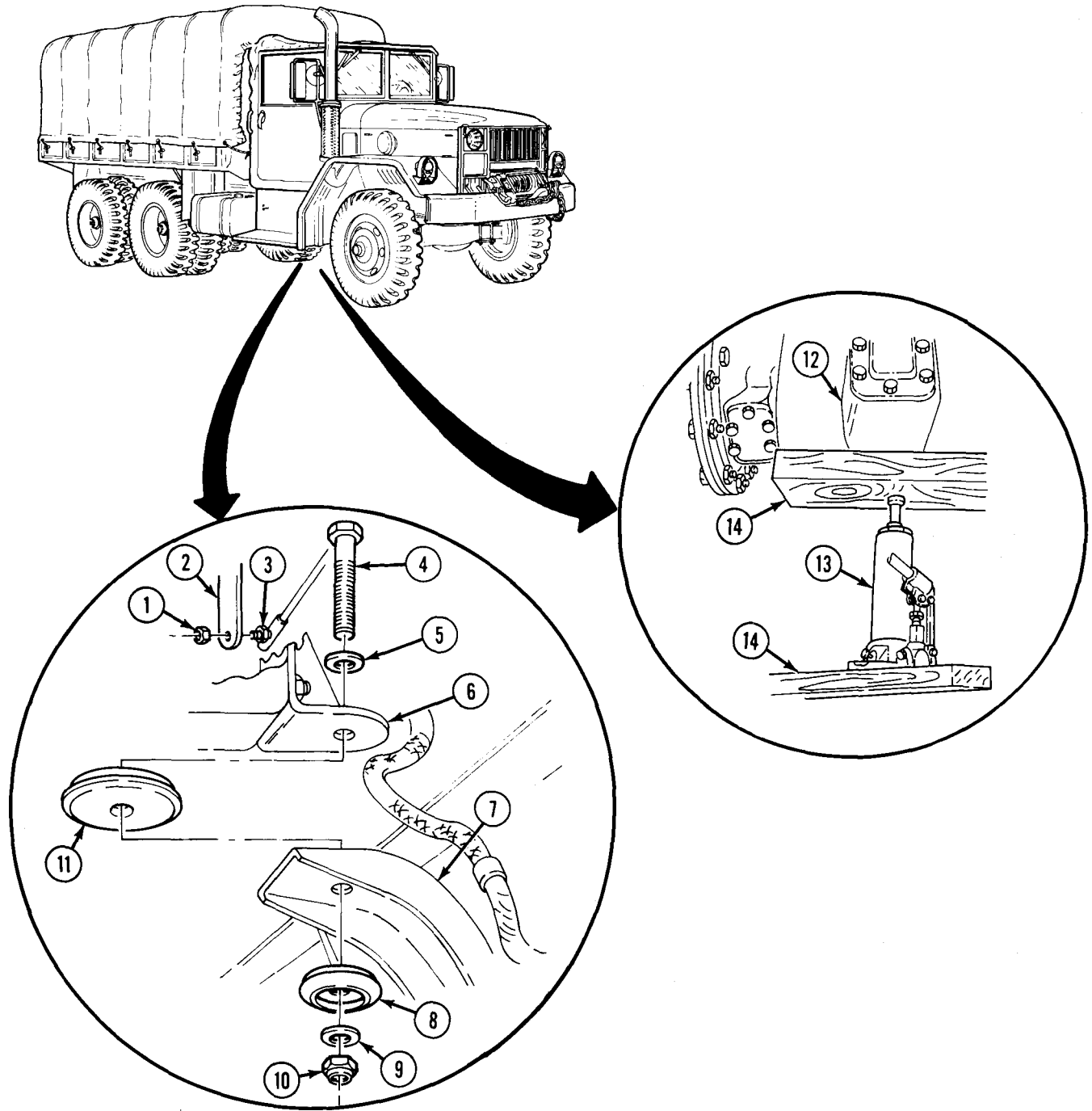

Section II. ENGINE LUBRICATION SYSTEM MAINTENANCE

**3-4. ENGINE LUBRICATION SYSTEM MAINTENANCE INDEX**

PARA. NO.	TITLE	PAGE NO.
3-5.	Oil Dipstick Tube Replacement	3-6
3-6.	Crankcase Breather Tube Maintenance	3-8
3-7.	Engine Oil Filter and Body Maintenance	3-10
3-8.	Crankcase Breather Tube Adapter Replacement	3-13

**3-5. OIL DIPSTICK TUBE REPLACEMENT**

This task covers:

**a. Removal**

**b. Installation**

**INITIAL SETUP:**

APPLICABLE MODELS

All

MATERIALS/PARTS

Lockwasher

Antiseize tape (Appendix C, Item 27)

REFERENCES (TM)

TM 9-2320-361-10

TM 9-2320-361-20P

EQUIPMENT CONDITION

- Parking brake set (TM 9-2320-361-10).
- Hood raised and secured (TM 9-2320-361-10).
- Dipstick removed (TM 9-2320-361-10).

**a. Removal**

1. Remove nut (1), lockwasher (7), and screw (3) from bracket (6). Discard lockwasher (7).
2. Remove dipstick tube (5) from engine (4) and bracket (6).

**NOTE**

Perform step 3 only if oil dipstick tube bracket needs replacement.

3. Remove two nuts (2) and bracket (6) from engine (4).

**b. Installation**

**NOTE**

- Male pipe threads must be wrapped with antiseize tape before installation.
- Perform step 1 only if oil dipstick tube bracket was removed.

1. Install bracket (6) on engine (4) with two nuts (2).
2. Insert dipstick tube (5) through bracket (6), and install dipstick tube (5) on engine (4).
3. Install screw (3), new lockwasher (7), and nut (1) on dipstick tube bracket (6).

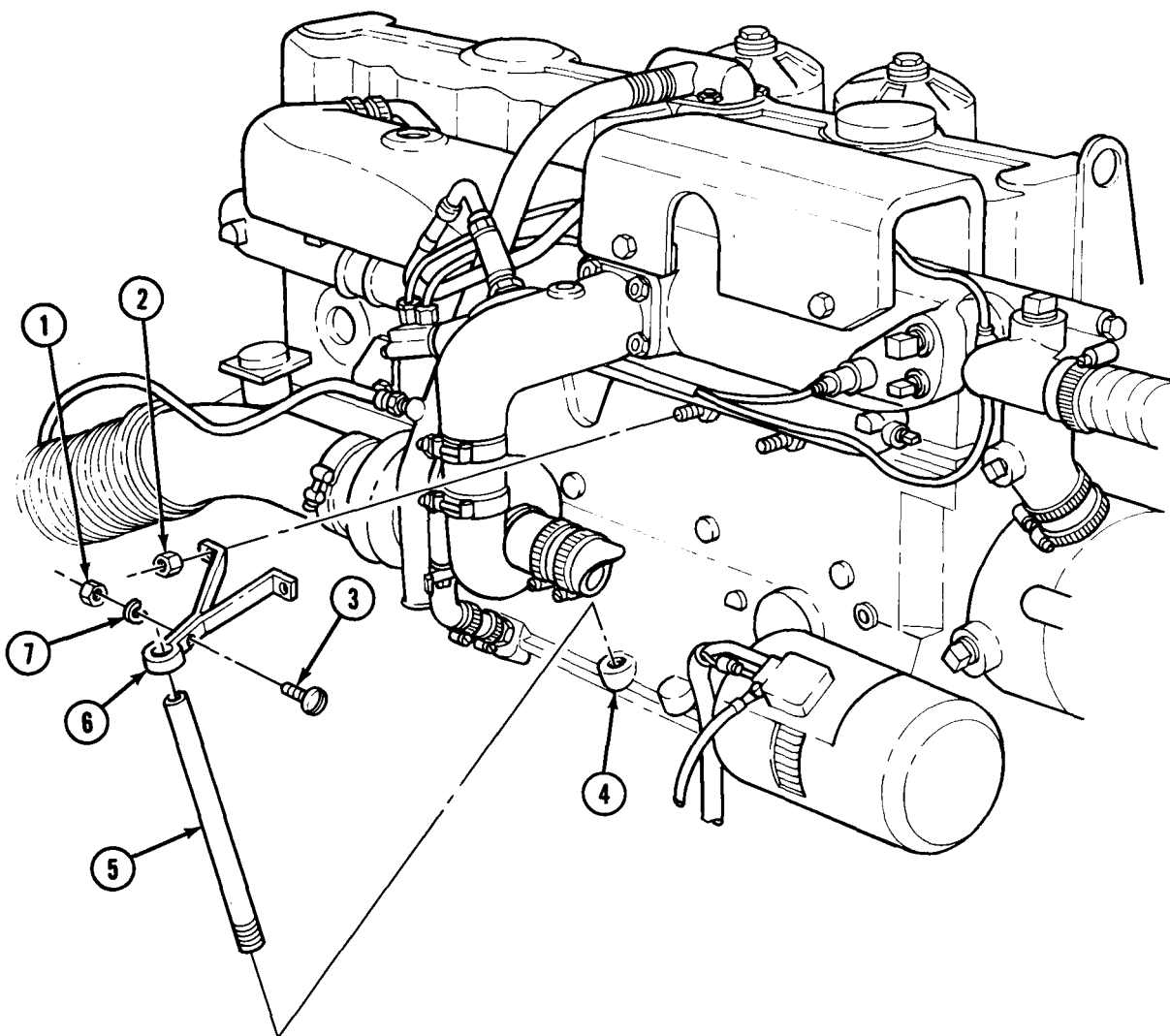
**3-5. OIL DIPSTICK TUBE REPLACEMENT (Contd)**

FOLLOW-ON TASK: Install dipstick (TM 9-2320-361-10).

### 3-6. CRANKCASE BREATHER TUBE MAINTENANCE

This task covers:

- a. Removal
- b. Cleaning and Inspection

c. Installation

**INITIAL SETUP:**

**APPLICABLE MODELS**

All

**MATERIALS/PARTS**

Lockwasher  
 Drycleaning solvent (Appendix C, Item 26)

**REFERENCES (TM)**

TM 9-2320-361-10  
 TM 9-2320-361-20P

**EQUIPMENT CONDITION**

- Parking brake set (TM 9-2320-361-10).
- Hood raised and secured (TM 9-2320-361-10).

**GENERAL SAFETY INSTRUCTIONS**

- Keep fire extinguisher nearby when using drycleaning solvent.
- Compressed air source will not exceed 30 psi (207 kPa).
- Eyeshields must be worn when cleaning with compressed air.

**a. Removal**

1. Disconnect tube (5) and remove adapter (6) from crankcase breather tube (4).
2. Remove screw (8) and lockwasher (7) from crankcase breather tube (4) and turbocharger (9). Discard lockwasher (7).
3. Loosen two clamps (2) and remove crankcase breather tube (4), hose (3), and two clamps (2) from breather tube adapter (1) and turbocharger (9).

**b. Cleaning and Inspection**

**WARNING**

- Drycleaning solvent is flammable and will not be used near open flame. Use only in well-ventilated places. Failure to do so may result in injury to personnel.
- Compressed air source will not exceed 30 psi (207 kPa). When cleaning with compressed air, eyeshields must be worn. Failure to wear eyeshields may result in injury to personnel.

Clean crankcase breather tube (4) and hose (3) with drycleaning solvent and dry with compressed air. Remove obstructions. Replace if bent.

**c. Installation**

1. Install hose (3) and crankcase breather tube (4) on breather tube adapter (1) with two clamps (2).
2. Install crankcase breather tube (4) on turbocharger (9) with new lockwasher (7) and screw (8).
3. Install adapter (6) on crankcase breather tube (4), and connect tube (5) to adapter (6).

3-6. CRANKCASE BREATHER TUBE MAINTENANCE (Contd)

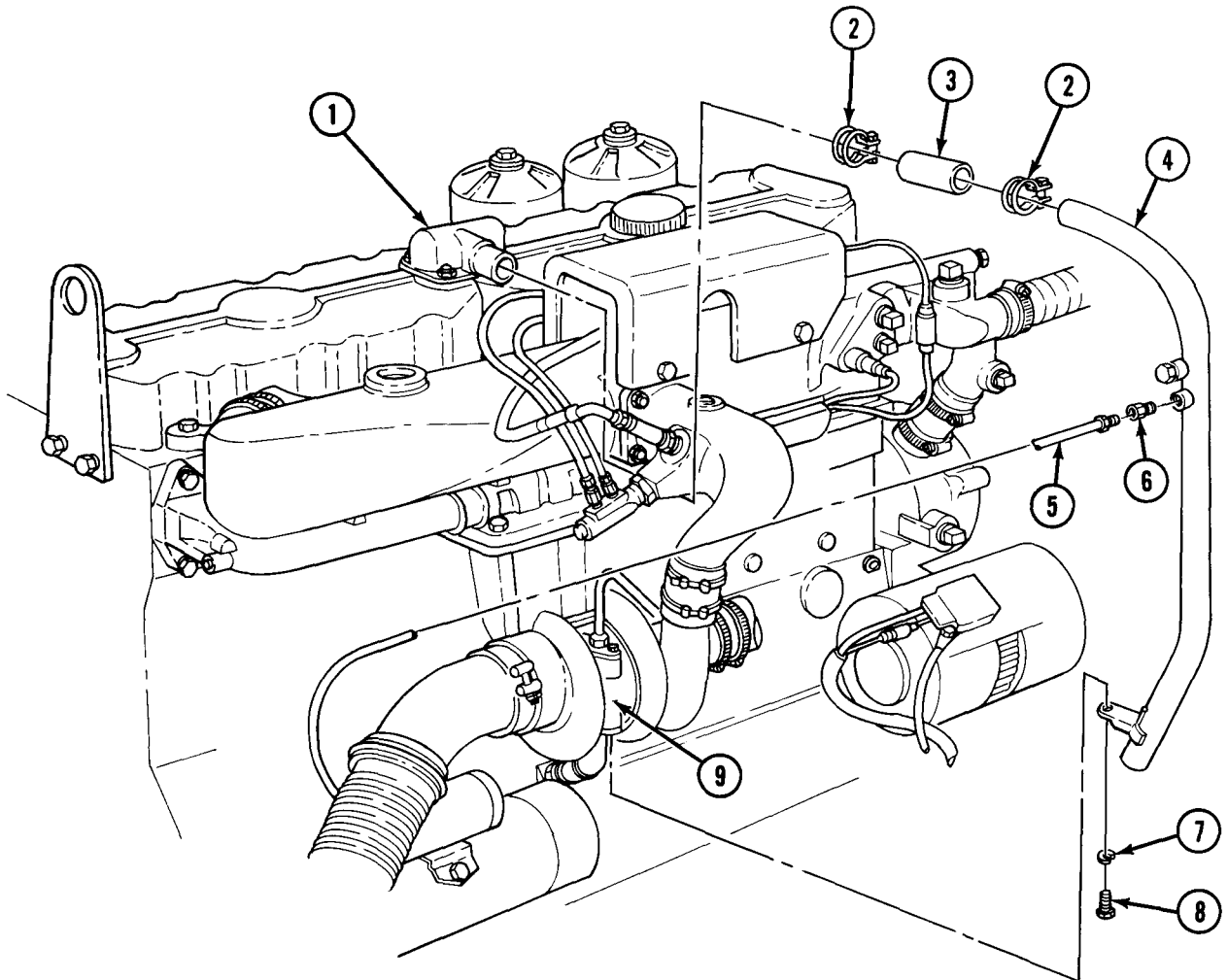



### 3-7. ENGINE OIL FILTER AND BODY MAINTENANCE

This task covers:

- a. Draining Oil
- b. Oil Filter Removal
- c. Body Disassembly

- d. Cleaning and Inspection
- e. Body Assembly
- f. Oil Filter Installation

**INITIAL SETUP:**

APPLICABLE MODELS

All

MATERIALS/PARTS

Four gaskets  
 Two cotter pins  
 Two filter elements  
 Two spacers  
 Drycleaning solvent (Appendix C, Item 26)  
 Lubricating oil, OE/HDO 30  
 (Appendix C, Item 19)

REFERENCES (TM)

LO 9-2320-209-12-1  
 TM 9-2320-361-10  
 TM 9-2320-361-20P

EQUIPMENT CONDITION

- Parking brake set (TM 9-2320-361-10).
- Hood raised and secured (TM 9-2320-361-10).

GENERAL SAFETY INSTRUCTIONS

- Do not drain oil when engine is hot.
- Keep fire extinguisher nearby when using drycleaning solvent.
- Compressed air source will not exceed 30 psi (207 kPa).
- Eyeshields must be worn when cleaning with compressed air.

#### a. Draining Oil

#### WARNING

Do not drain oil when engine is hot. Hot oil may cause injury to personnel.

#### NOTE

Have drainage container ready to catch oil.

1. Remove two drainplugs (3) and spacers (2) from engine oil pan (1), and allow oil to completely drain. Discard spacers (2).
2. Install two new spacers (2) and drainplugs (3) on engine oil pan (1).

#### b. Oil Filter Removal

#### NOTE

Have drainage container ready to catch oil.

1. Remove pipe plug (6) from filter housing (7) and allow oil to drain,

#### NOTE

Both engine oil filter bodies are removed the same way.

2. Loosen center post (4) and remove body (5) and gasket (8) from filter housing (7). Discard gasket (8).
3. Install pipe plug (6) on filter housing (7).

**3-7. ENGINE OIL FILTER AND BODY MAINTENANCE (Contd)**

**c. Body Disassembly**

**NOTE**

Both engine oil filter bodies are disassembled the same.

1. Remove cotter pin (10), filter element (9), cup (13), and spring (12) from center post (4) and body (5). Discard cotter pin (10) and filter element (9).
2. Remove center post (4) and gasket (11) from body (5). Discard gasket (11).

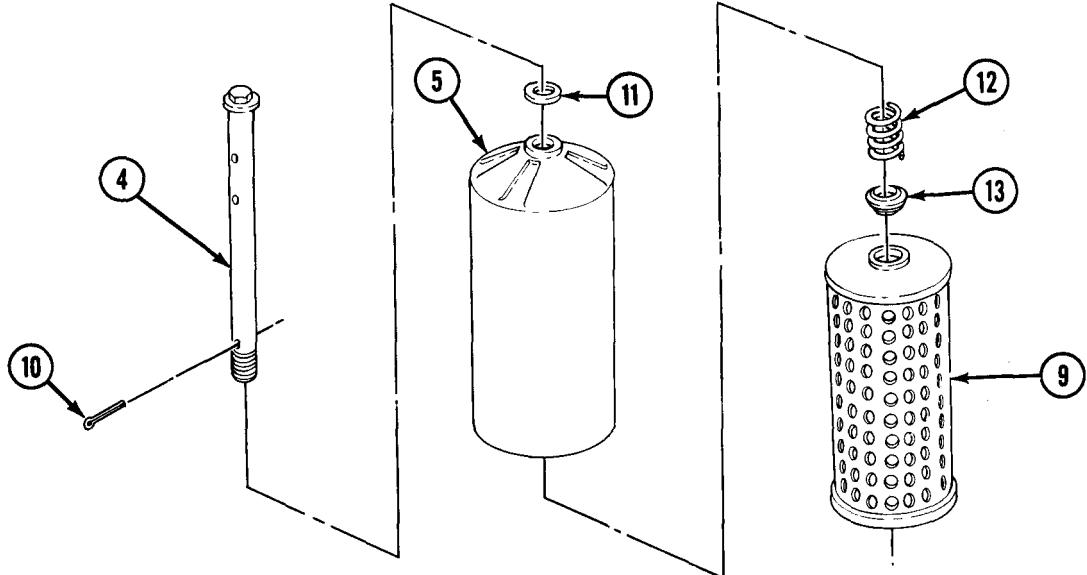
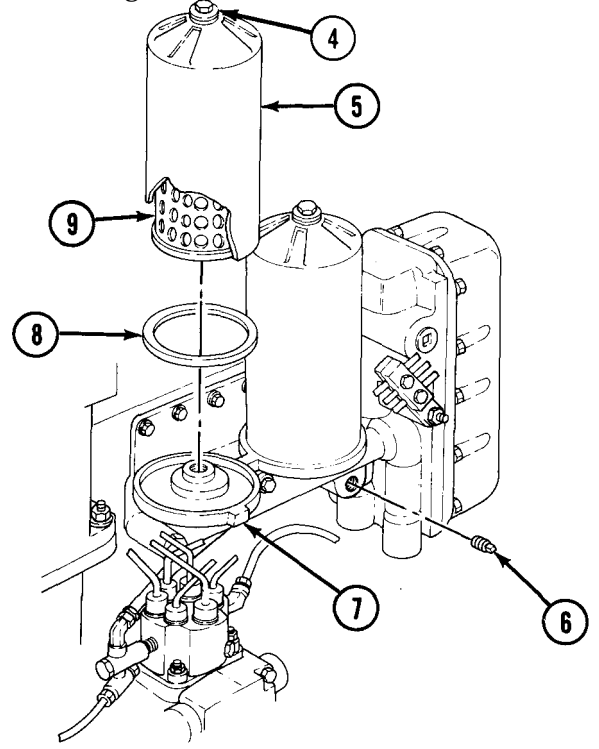
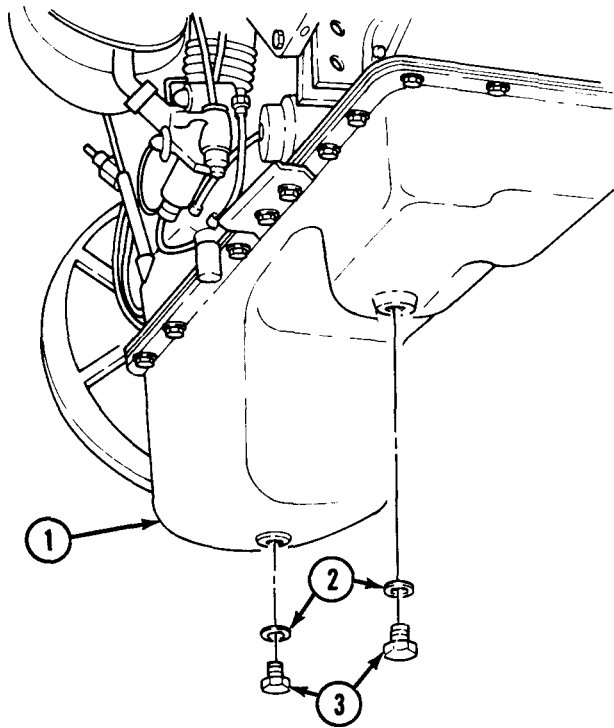

**3-7. ENGINE OIL FILTER AND BODY MAINTENANCE (Contd)**

**d. Cleaning and Inspection**

**WARNING**

- Drycleaning solvent is flammable and will not be used near open flame. Use only in well-ventilated places. Failure to do so may result in injury to personnel.
- Compressed air source will not exceed 30 psi (207 kPa). When cleaning with compressed air, eyeshields must be worn. Failure to wear eyeshields may result in injury to personnel.

1. Clean center post (1) and body (2) with drycleaning solvent and dry with compressed air.
2. Inspect body (2) for cracks. Replace body (2) if cracked.
3. Inspect center post (1) for stripped threads. Replace center post (1) if threads are stripped.
4. Inspect filter housing (4) for cracks, nicks, and stripped threads. Notify your supervisor if filter housing (4) is cracked, nicked, or threads are stripped.
5. Inspect cup (8) for cracks and grooves. Replace cup (8) if cracked or grooved.
6. Inspect spring (7) for cracks and breaks. Replace spring (7) if cracked or broken.

**e. Body Assembly**

**NOTE**

Both engine oil filter bodies are assembled the same.

1. Place new gasket (6) on center post (1) and install center post (1) on filter body (2).
2. Install spring (7), cup (8), new filter element (9), and new cotter pin (5) on center post (1) and body (2).

**f. Oil Filter Installation**

**NOTE**

Both engine oil filter bodies are installed the same.

1. Coat new gasket (4) with light film of engine oil.
2. Install new gasket (4) and body (2) on filter housing (3). Tighten center post (1) 60 lb-ft (81 N·m).

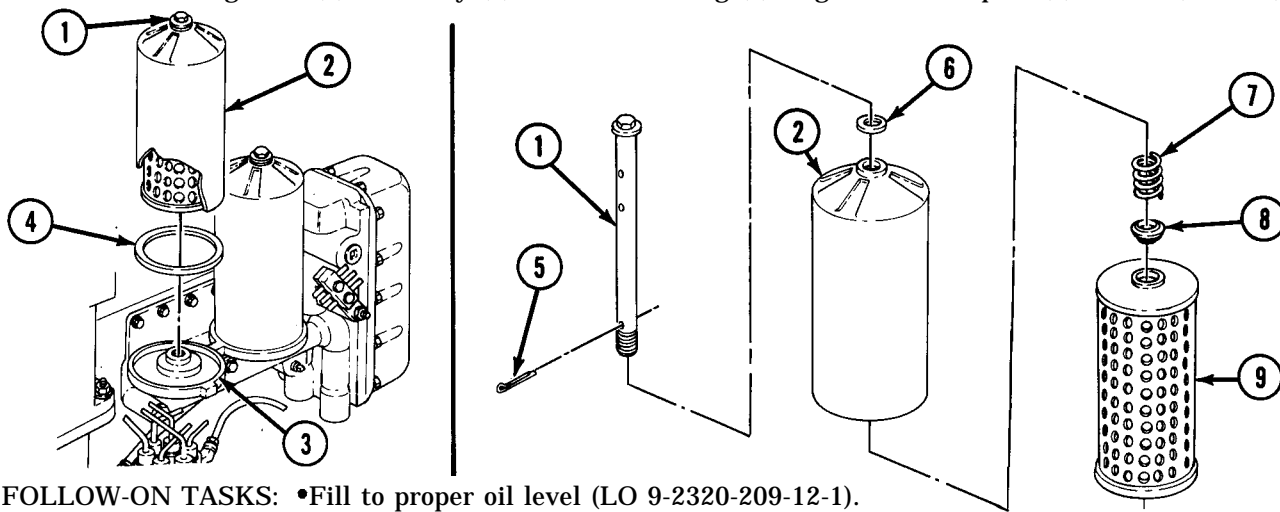

FOLLOW-ON TASKS: •Fill to proper oil level (LO 9-2320-209-12-1).  
 •Start engine (TM 9-2320-361-10) and check for leaks.

### 3-8. CRANKCASE BREATHER TUBE ADAPTER REPLACEMENT

This task covers:

#### a. Removal

#### b. Installation

#### INITIAL SETUP:

##### APPLICABLE MODELS

All

##### MATERIALS/PARTS

Four locknuts

Two gaskets

##### REFERENCES (TM)

TM 9-2320-361-10

TM 9-2320-361-20P

##### EQUIPMENT CONDITION

- Parking brake set (TM 9-2320-361-10).
- Hood raised and secured (TM 9-2320-361-10).

#### a. Removal

1. Loosen clamp (5) and disconnect hose (4) from crankcase breather tube adapter (3).
2. Remove four locknuts (1), washers (2), and clamp (8) from crankcase breather tube adapter (3). Discard locknuts (1).
3. Remove crankcase breather tube adapter (3) and two gaskets (7) from two rocker arm covers (6). Discard gaskets (7).

#### b. Installation

1. Install two new gaskets (7) and crankcase breather tube adapter (3) on two rocker arm covers (6) with clamp (8), four washers (2), and new locknuts (1). Tighten locknuts (1) 55-60 lb-in. (6-7 N·m).
2. Connect hose (4) to adapter (3) and tighten clamp (5).

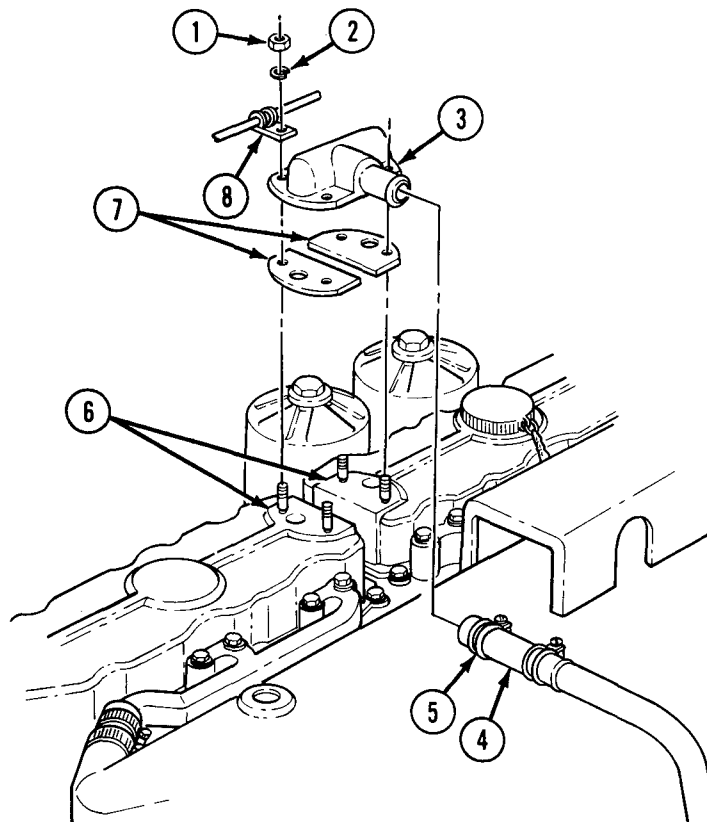

Section III. CLUTCH SYSTEM MAINTENANCE

**3-9. CLUTCH SYSTEM MAINTENANCE INDEX**

PARA. NO.	TITLE	PAGE NO.
3-10.	Clutch Control Linkage Maintenance	3-14
3-11.	Pedal Shaft Support Replacement	3-19

**3-10. CLUTCH CONTROL LINKAGE MAINTENANCE**

This task covers:

- a. Removal
- b. Installation
- c. Adjustment

**INITIAL SETUP:**

APPLICABLE MODELS

All

MATERIALS/PARTS

Four locknuts  
Two woodruff keys  
Chalk (Appendix C, Item 9)

REFERENCES (TM)

LO 9-2320-209-12-1  
TM 9-2320-361-10  
TM 9-2320-361-20P

EQUIPMENT CONDITION

- Parking brake set (TM 9-2320-361-10).
- Hood raised and secured (TM 9-2320-361-10).
- Accelerator pedal, bracket, and rod removed (para. 3-33).
- Transmission power takeoff shift linkage removed (vehicles with transmission PTO only) (para. 13-20).
- Hydraulic master cylinder removed (para. 8-10).

**a. Removal**

1. Remove clutch return spring (7) from clutch shaft lever (6) and frame (10).
2. Mark shaft of clutch pedal (3) with chalk next to remote control lever (14).
3. Remove screw (1), clutch pedal (3), and rubber bumper (2) from remote control lever (14).
4. Remove locknut (13), screw (4), remote control lever (14), and woodruff key (12) from pedal lever shaft (11). Discard locknut (13) and woodruff key (12).
5. Remove locknut (9), screw (5), and rod (8) from clutch shaft lever (6). Discard locknut (9).
6. Remove locknut (26), screw (21), and remote control lever (20) with rod (8) from shaft (22). Discard locknut (26).

**NOTE**

Do not remove spring loaded pin from clevis.

7. Pull pin (24) to one side of clevis (25) and remove remote control lever (20) from clevis (25).
8. Loosen nut (23) and remove clevis (25) and nut (23) from rod (8).
9. Remove locknut (18), screw (17), clutch shaft lever (6), and pedal lever shaft (11) from brake lever (19) and shaft support (16). Discard locknut (18).
10. Remove woodruff key (15) from shaft (11). Discard woodruff key (15).

3-10. CLUTCH CONTROL LINKAGE MAINTENANCE (Contd)

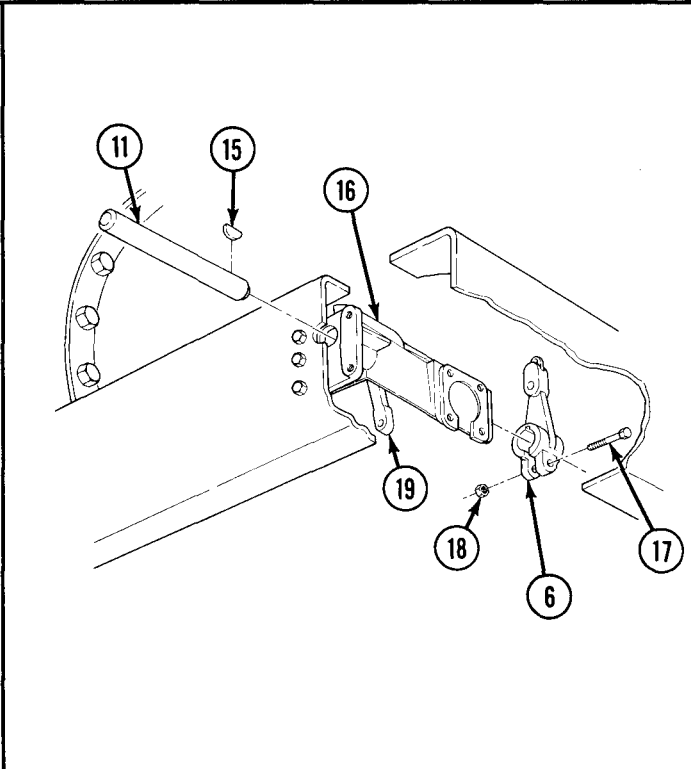
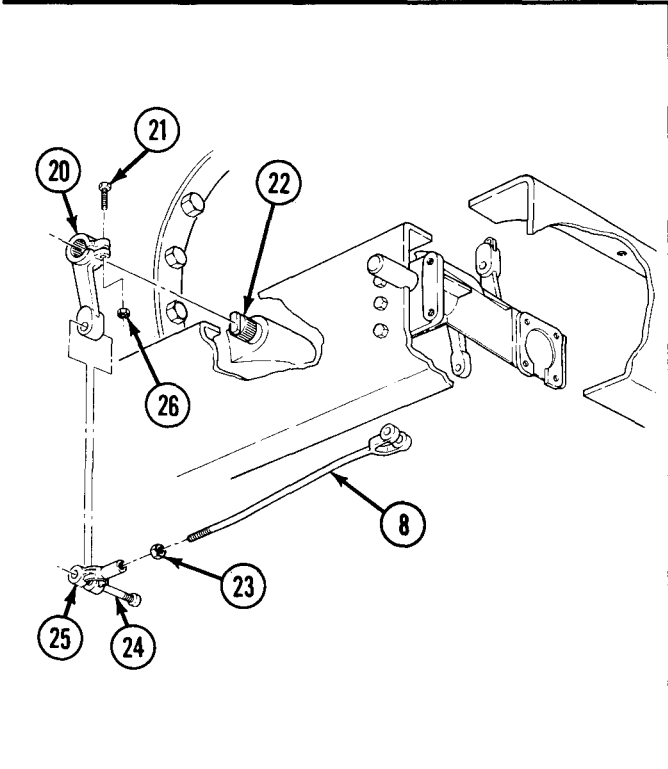
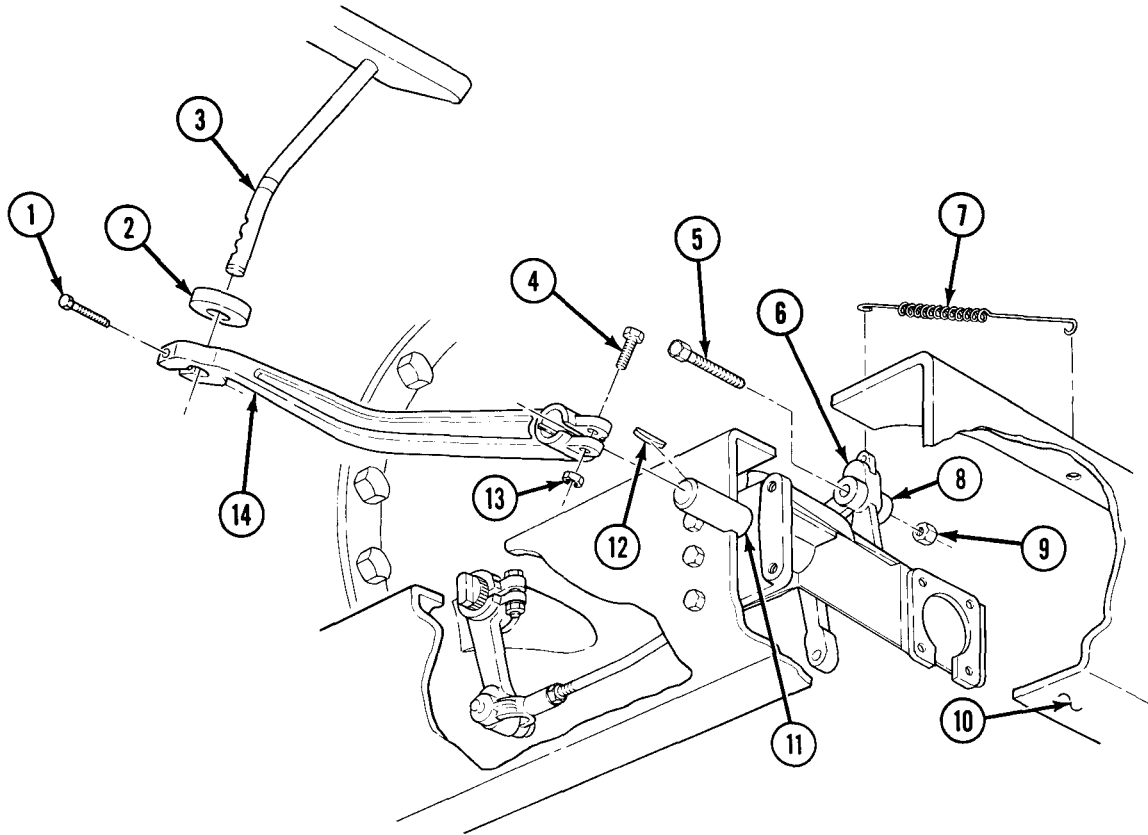

### 3-10. CLUTCH CONROL LINKAGE MAINTENANCE (Contd)

#### b. Installation

1. Install new woodruff key (2) on pedal lever shaft (1).
2. Install clutch shaft lever (3) on pedal lever shaft (1) with screw (4) and new locknut (5). Do not tighten locknut (5).
3. Install pedal lever shaft (1) through brake lever (6) and shaft support (7).
4. Position clutch shaft lever (3) flush with end of pedal lever shaft (1) and tighten locknut (5).
5. Install remote control lever (15) on clutch shaft (9); position one spline to rear of clutch shaft (9) centerline. Install screw (8) and new locknut (14). Do not tighten.
6. Push lower end of remote control lever (15) forward until resistance is felt. Measure distance from center of bottom hole (16) to transmission flange (17).

#### NOTE

Measurement taken in step 6 should be approximately 3.25 in. (8.26 cm). If measurement is not approximately 3.25 in. (8.26 cm), perform step 7.

7. Remove remote control lever (15) and rotate it one spline at a time until measurement is correct.
8. Tighten locknut (14).
9. Install nut (11) and clevis (13) on rod (10).
10. Install rod (10) on clutch shaft lever (3) with screw (23) and new locknut (26). Make sure head of pin (12) is facing transmission.
11. Install rod (10) on remote control lever (15) with pin (12). Press pin (12) into clevis (13) until head of pin (12) seats against clevis (13).
12. Install clutch return spring (24) on clutch shaft lever (3) and frame (25).
13. Install new woodruff key (27) on pedal lever shaft (1).
14. Install remote control lever (21) on pedal lever shaft (1) with screw (22) and new locknut (28).
15. Install shaft of clutch pedal (20) and rubber bumper (19) on remote control lever (21) with screw (18). Aline chalk mark on shaft of clutch pedal (20) with remote control lever (21) and tighten screw (18).
16. Mark shaft of clutch pedal (20) with chalk where shaft passes through floor (30).
17. Push clutch pedal (20) down until resistance is felt and again mark shaft of clutch pedal (20) with chalk.
18. Release clutch pedal (20) and measure distance between two chalk marks (29). Distance (pedal free travel) should be 1.5-2 in. (3.8-5.1 cm).
19. If pedal free travel is not 1.5-2 in. (3.8-5.1 cm), perform clutch adjustment procedure.

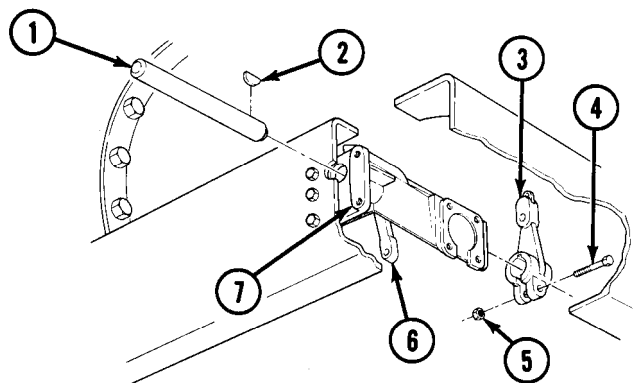

3-10. CLUTCH CONTROL LINKAGE MAINTENANCE (Contd)

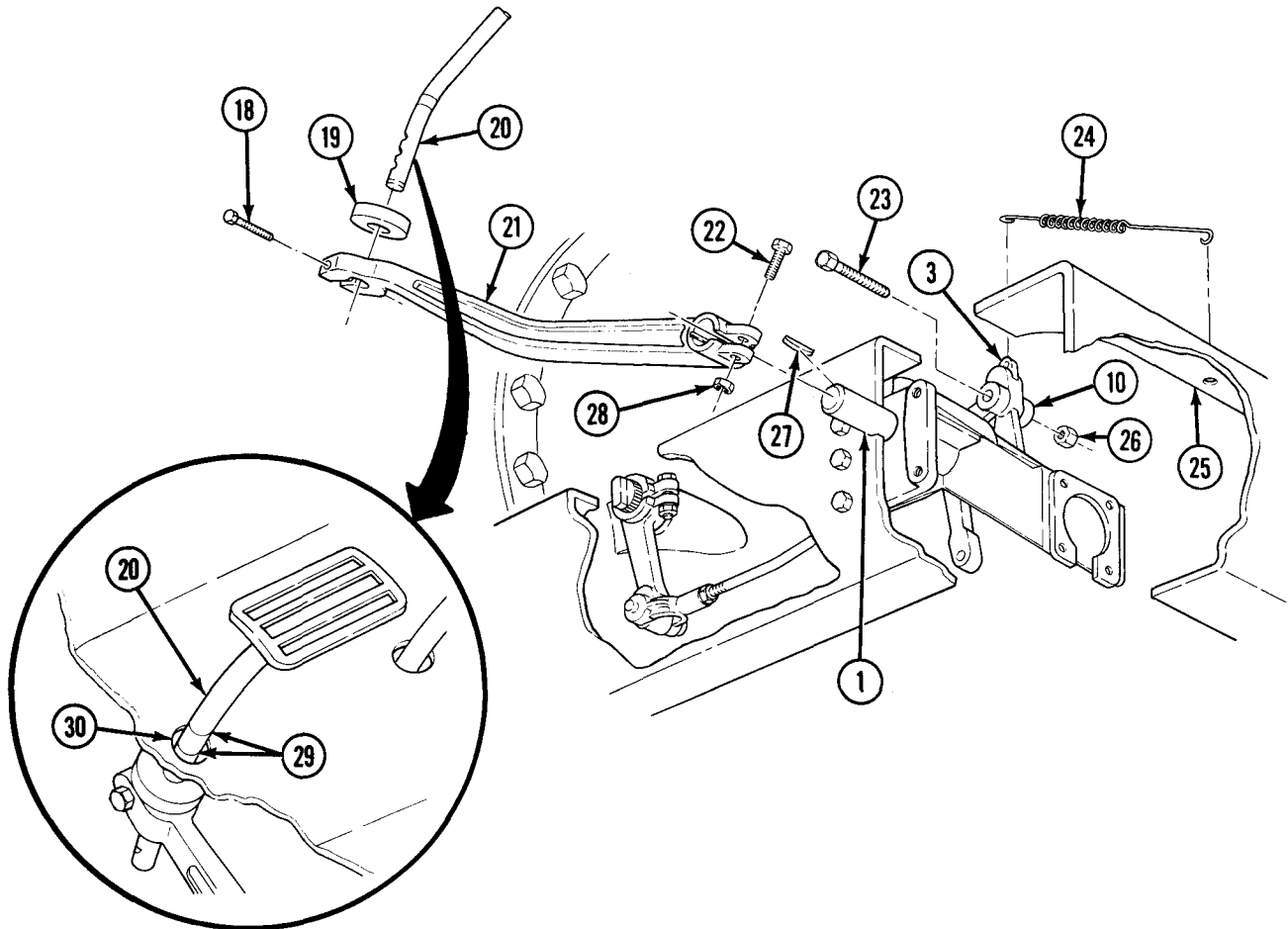
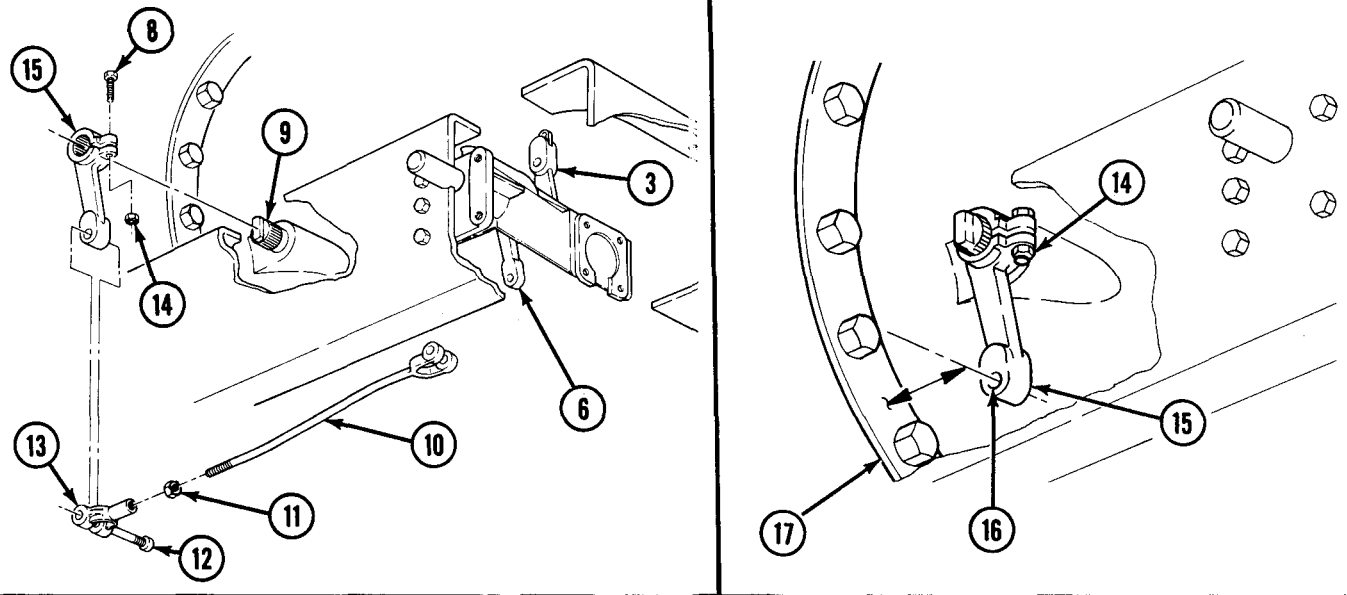



**3-10. CLUTCH CONTROL LINKAGE MAINTENANCE (Contd)**

**c. Adjustment**

1. Loosen nut (3), pull pin (4) to one side of clevis (5), and remove clevis (5) from remote control lever (1).
2. If pedal free travel is less than 1.5 in. (3.8 cm), shorten length of rod (2) by tightening clevis (5) on rod (2).
3. If pedal free travel is more than 2 in. (5.1 cm), lengthen rod (2) by loosening clevis (5) on rod (2).
4. Install clevis (5) on remote control lever (1) with pin (4). Press pin (4) into clevis (5) until head of pin (4) seats against clevis (5).
5. Recheck pedal free travel (steps 17-18, subtask b.) and tighten nut (3).

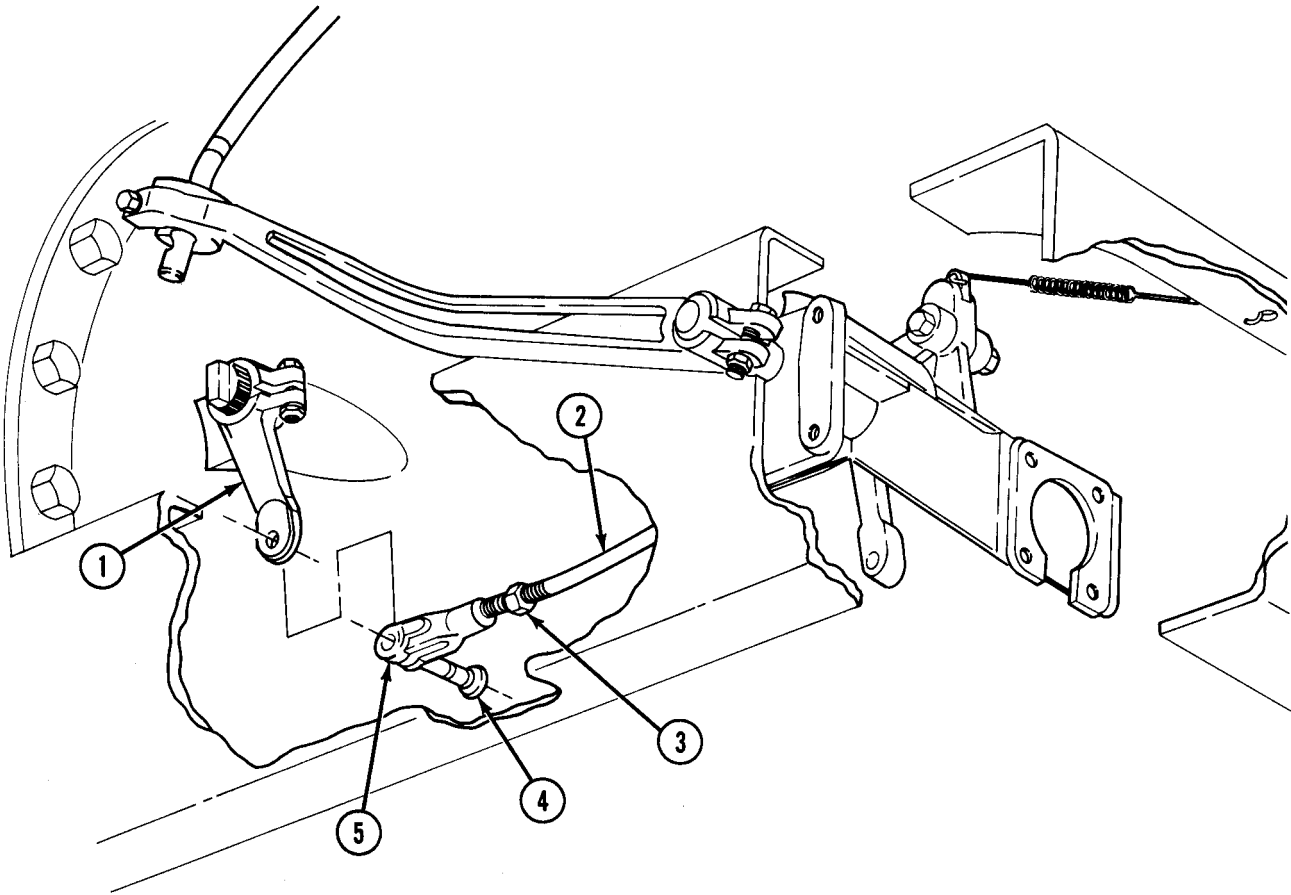

- FOLLOW-ON TASKS:**
- Lubricate clutch control linkage (LO 9-2320-209-12-1).
  - Install hydraulic master cylinder (para 8-10).
  - Install transmission power takeoff shift linkage (vehicles with transmission PTO only) (para. 13-20).
  - Install accelerator pedal, bracket, and rod (para. 3-33).

### 3-11. PEDAL SHAFT SUPPORT REPLACEMENT

This task covers:

#### a. Removal

#### b. Installation

INITIAL SETUP:

#### APPLICABLE MODELS

All

#### REFERENCES (TM)

TM 9-2320-361-20P

#### MATERIALS/PARTS

Five locknuts

#### EQUIPMENT CONDITION

Clutch control linkage removed (para. 3-10).

#### a. Removal

1. Remove five locknuts (4), screws (1), and pedal shaft support (3) from chassis (2). Discard locknuts (4).
2. Remove two grease fittings (5) from pedal shaft support (3).

#### b. Installation

1. Install two grease fittings (5) in pedal shaft support (3).
2. Install pedal shaft support (3) on chassis (2) with five screws (1) and new locknuts (4).

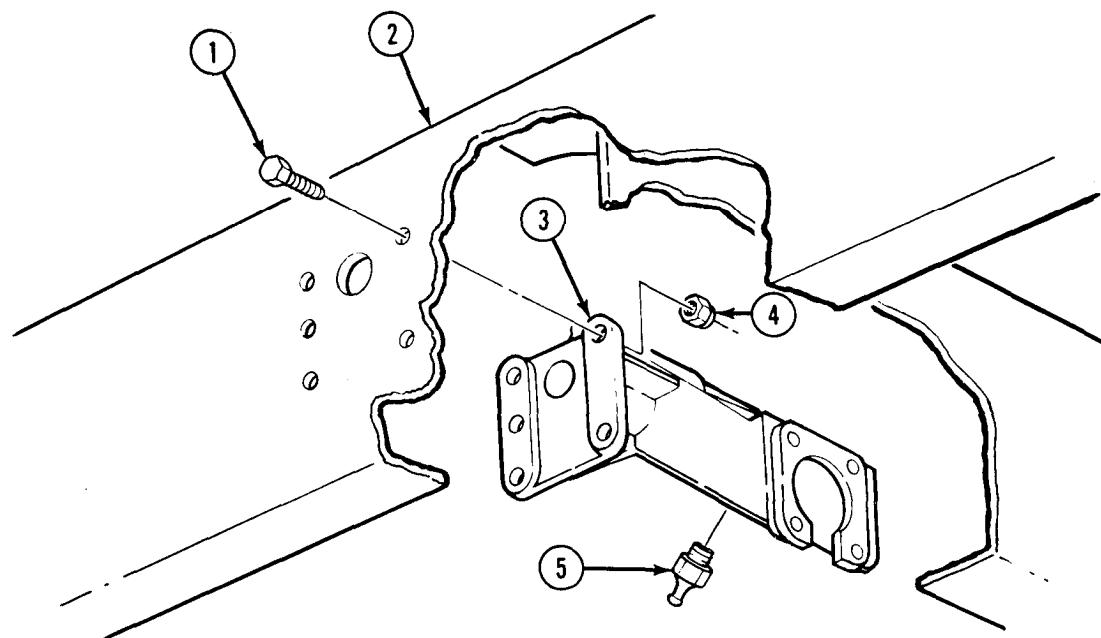

FOLLOW-ON TASK: Install clutch control linkage (para. 3-10).

Section IV. AIR INTAKE SYSTEM MAINTENANCE

**3-12. AIR INTAKE SYSTEM MAINTENANCE INDEX**

PARA. NO.	TITLE	PAGE NO.
3-13.	Air Intake Tube and Cap Replacement	3-20
3-14.	Air Cleaner Cap and Element Replacement	3-22
3-15.	Air Cleaner Assembly Maintenance	3-24
3-16.	Air Cleaner Indicator and Tube Maintenance	3-25

**3-13. AIR INTAKE TUBE AND CAP REPLACEMENT**

This task covers:

**a. Removal**

**b. Installation**

**INITIAL SETUP:**

APPLICABLE MODELS

All

REFERENCES (TM)

TM 9-2320-361-10

TM 9-2320-361-20P

EQUIPMENT CONDITION

- Parking brake set (TM 9-2320-361-10).
- Hood raised and secured (TM 9-2320-361-10).

**a. Removal**

1. Loosen clamp (2) and remove cap (1) from air cleaner shell (12).
2. Loosen clamps (6) and (8) and remove air intake tube (7) from hoses (5) and (9).
3. Loosen clamp (4) and remove hose (5) from air cleaner head (3).
4. Loosen clamp (10) and remove hose (9) from turbocharger (11).

**b. Installation**

1. Install hose (9) on turbocharger (11) with clamp (10).
2. Install hose (5) on air cleaner head (3) with clamp (4).
3. Install air intake tube (7) on hoses (5) and (9) with clamps (6) and (8).
4. Install cap (1) on air cleaner shell (12) with clamp (2).

3-13. AIR INTAKE TUBE AND CAP REPLACEMENT (Contd)

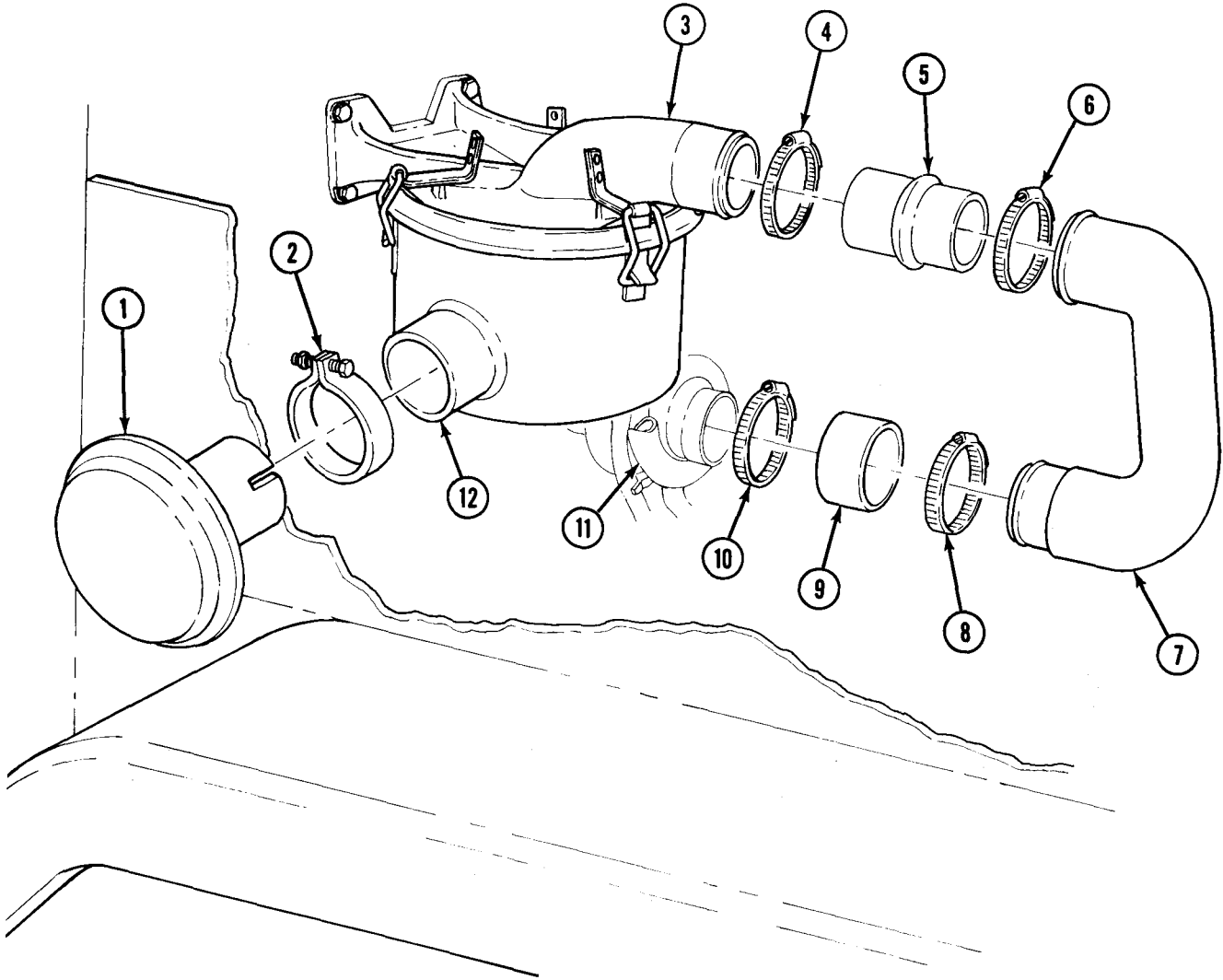

**3-14. AIR CLEANER CAP AND ELEMENT REPLACEMENT**

This task covers:

- a. Cap Removal
- b. Element Removal

- c. Element Installation
- d. Cap Installation

INITIAL SETUP:

APPLICABLE MODELS

All

MATERIALS/PARTS

Filter element

REFERENCES (TM)

FM 21-40  
TM 9-2320-361-10  
TM 9-2320-361-20P

EQUIPMENT CONDITION

- Parking brake set (TM 9-2320-361-10).
- Hood raised and secured (TM 9-2320-361-10).

GENERAL SAFETY INSTRUCTIONS

- Observe NBC warning.
- NBC contaminated filters must be handled using adequate precautions.

**WARNING**

- If NBC exposure is suspected, all air filter media should be handled by personnel wearing protective equipment. Consult your unit NBC officer or NBC NCO for appropriate handling or disposal instructions.
- NBC contaminated filters must be handled using adequate precautions (FM 21-40) and must be disposed of by trained personnel.

**a. Cap Removal**

Loosen clamp (2), and remove cap (1) and clamp (2) from air cleaner shell (3).

**b. Element Removal**

1. Unlatch three clamps (5) and remove air cleaner shell (3) from air cleaner head (4).
2. Remove filter element (7) from air cleaner shell (3). Discard filter element (7).
3. Remove seal (6) from air cleaner head (4).

**3-14. AIR CLEANER ELEMENT REPLACEMENT (Contd)**

**c. Element Installation**

1. Install seal (6) in air cleaner head (4).
2. Install new filter element (7) in air cleaner shell (3).
3. Aline air cleaner shell (3) with air cleaner head (4) and install with three clamps (5).

**d. Cap Installation**

Install clamp (2) and cap (1) to air cleaner shell (3) and tighten clamp (2).

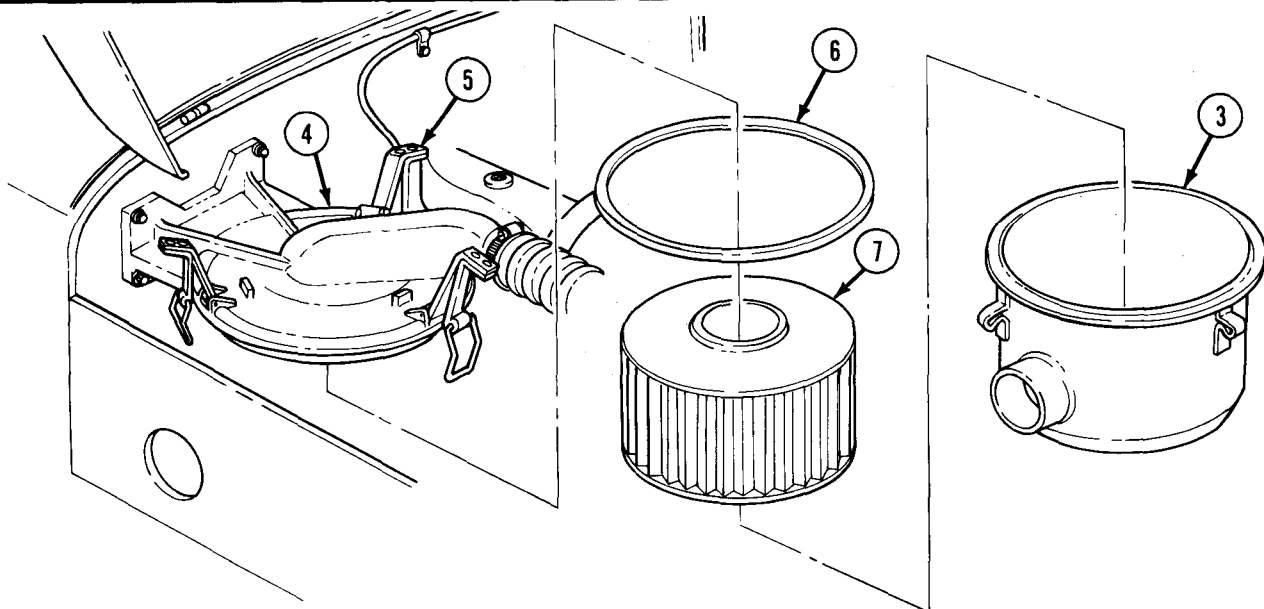
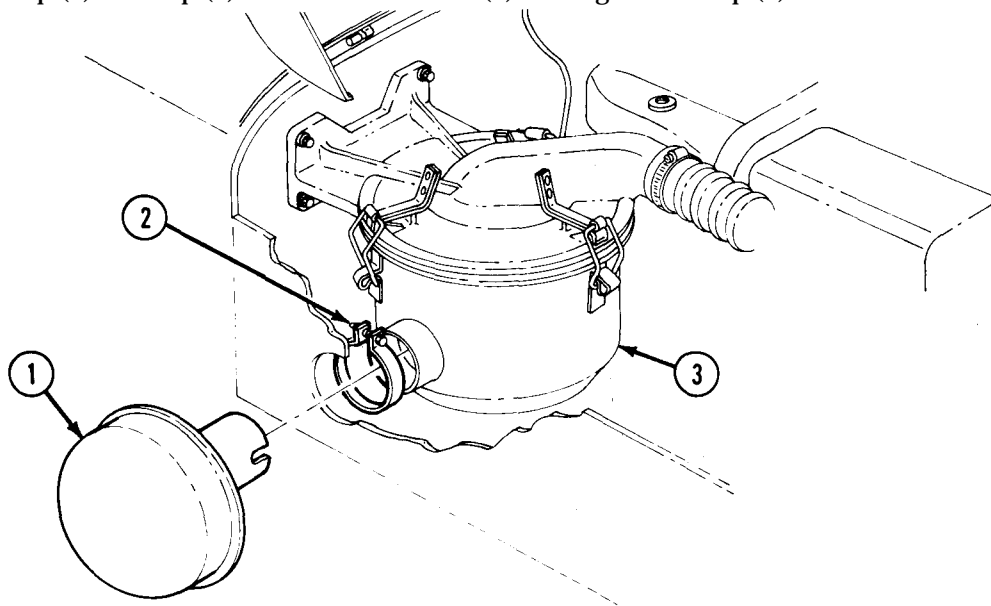

**FOLLOW-ON TASK.** Start engine (TM 9-2320-361-10) and make sure air filter indicator in cab indicates green (TM 9-2320-361-10).

**3-15. AIR CLEANER ASSEMBLY MAINTENANCE**

This task covers:

- a. Removal
- b. Inspection

- c. Installation

**INITIAL SETUP:**

APPLICABLE MODELS

All

MATERIALS/PARTS

Four lockwashers  
Antiseize tape (Appendix C, Item 27)

PERSONNEL REQUIRED

Two

REFERENCES (TM)

TM 9-2320-361-10  
TM 9-2320-361-20P

EQUIPMENT CONDITION

- Parking brake set (TM 9-2320-361-10).
- Hood raised and secured (TM 9-2320-361-10).
- Air intake tube and cap removed (para. 3-13).
- Air cleaner element removed (para. 3-14).

**a. Removal**

1. Disconnect tube (2) from connector (3), and remove connector (3) from air cleaner head (4).

**NOTE**

Assistant will help with step 2.

2. Remove four nuts (1), screws (6), lockwashers (5), and air cleaner head (4) from firewall (7). Discard lockwashers (5).

**b. Inspection**

Inspect air cleaner head (4) for cracks or damage that would allow unfiltered air to enter. Replace air cleaner head (4) if cracked or damaged.

**c. Installation**

**NOTE**

Assistant will help with step 1.

1. Install air cleaner head (4) on firewall (7) with four screws (6), new lockwashers (5), and nuts (1).

**NOTE**

Male pipe threads must be wrapped with antiseize tape before installation

2. Install connector (3) on air cleaner head (4).
3. Connect tube (2) to connector (3).

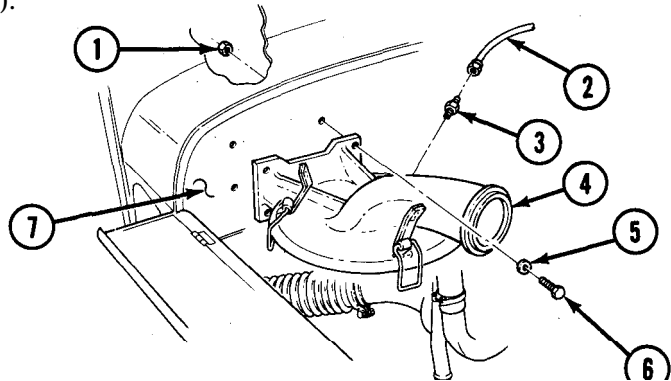

- FOLLOW-ON TASKS:
- Install air cleaner element (para. 3-14).
  - Install air intake tube and cap (para. 3-13).

### 3-16. AIR CLEANER INDICATOR AND TUBE MAINTENANCE

This task covers:

- a. Testing
- b. Removal

- c. Inspection and Cleaning
- d. Installation

INITIAL SETUP:

**APPLICABLE MODELS**

All

**MATERIALS/PARTS**

Antiseize tape (Appendix C, Item 27)

**PERSONNEL REQUIRED**

Two

**REFERENCES (TM)**

TM 9-2320-361-10

TM 9-2320-361-20P

**EQUIPMENT CONDITION**

- Parking brake set (TM 9-2320-361-10).
- Hood raised and secured (TM 9-2320-361-10).

**GENERAL SAFETY INSTRUCTIONS**

- Compressed air source will not exceed 30 psi (207 kPa).
- Eyeshields must be worn when cleaning with compressed air.

#### a. Testing

1. Loosen clamp (6) and remove cap (7) and clamp (6) from air cleaner (5).
2. Start engine (TM 9-2320-361-10) and run at 1200 rpm.
3. Using piece of cardboard (4), cover approximately 90% of air cleaner assembly (5) opening.
4. Observe air cleaner indicator (2) to see if red band (3) is visible. If red band is visible, indicator works properly. If not, air cleaner indicator (2) is defective or tube (1) is obstructed. Stop engine (TM 9-2320-361-10).
5. Remove cardboard (4) and install cap (7) on air cleaner (5) with clamp (6).

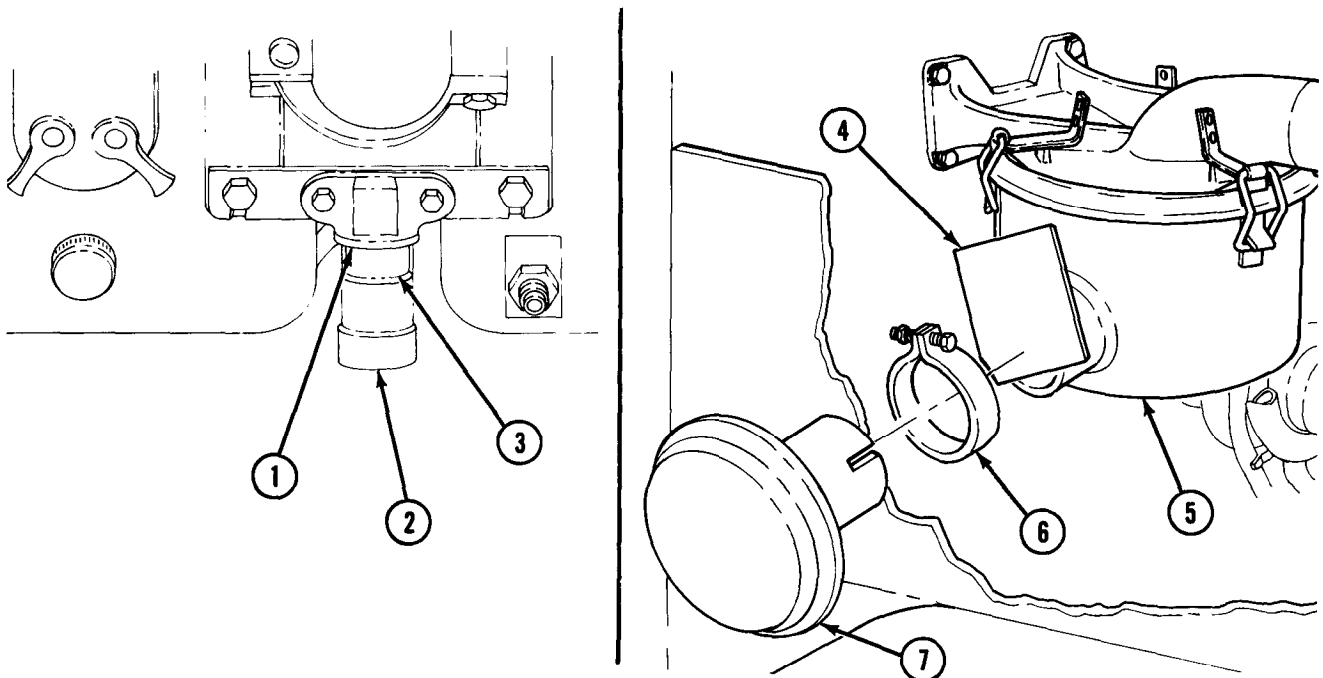



### 3-16. AIR CLEANER INDICATOR AND TUBE MAINTENANCE (Contd)

#### b. Removal

1. Disconnect tube (6) from connector (7) and remove connector (7) from air cleaner head (8).

#### NOTE

Assistant will help perform step 2.

2. Remove two nuts (4), screws (1), and clamps (3) from tube (6) and firewall (5).
3. Remove two nuts (9), screws (13), and washers (12) from air cleaner indicator (11).
4. Disconnect tube (6) from adapter (10) and remove air cleaner indicator (11).
5. Remove adapter (10) from air cleaner indicator (11).
6. Remove tube (6) and grommet (2) from firewall (5).

#### c. Inspection and Cleaning

1. Inspect tube (6) for kinks and obstruction. Replace tube (6) if kinked or obstructed.

#### WARNING

Compressed air source will not exceed 30 psi (207 kPa). When cleaning with compressed air, eyeshields must be worn. Failure to wear eyeshields may result in injury to personnel.

2. Clean tube (6) by blowing through it with compressed air.
3. Inspect connector (7), adapter (10), and fittings on tube (6) for stripped threads. Replace connector (7), adapter (10), or fittings on tube (6) if threads are stripped.

#### d. Installation

#### NOTE

Male pipe threads must be wrapped with antiseize tape before installation.

1. Install grommet (2) and tube (6) through firewall (5).
2. Install adapter (10) on air cleaner indicator (11).
3. Connect air cleaner indicator (11) to tube (6).
4. Install two screws (13), washers (12), and nuts (9).

#### NOTE

Assistant will help perform step 5.

5. Install tube (6) on firewall (5) with two clamps (3), screws (1), and nuts (4). Do not tighten nuts (4).
6. Install connector (7) on air cleaner head (8), and connect tube (6) to adapter (7). Tighten nuts (4).

3-16. AIR CLEANER INDICATOR AND TUBE MAINTENANCE (Contd)

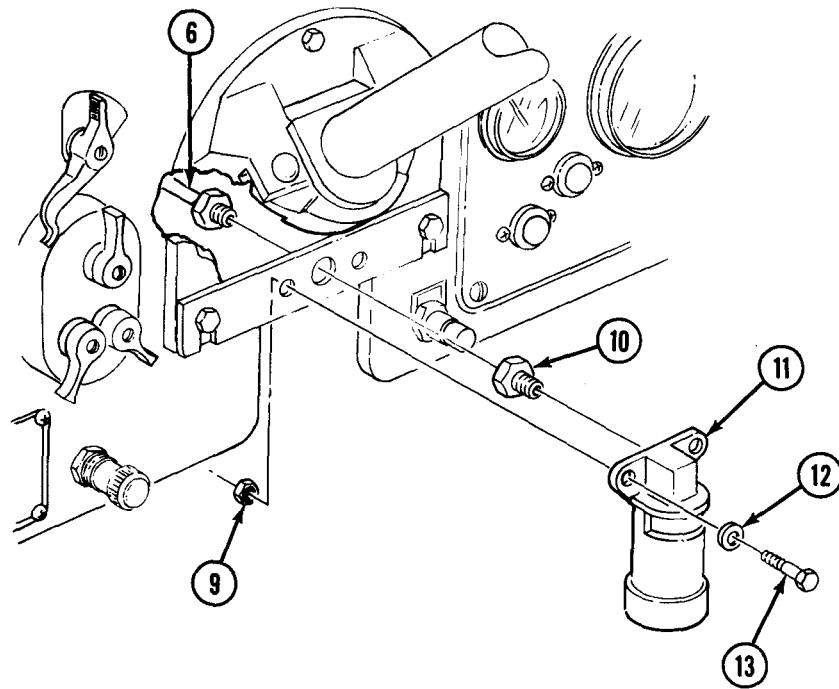
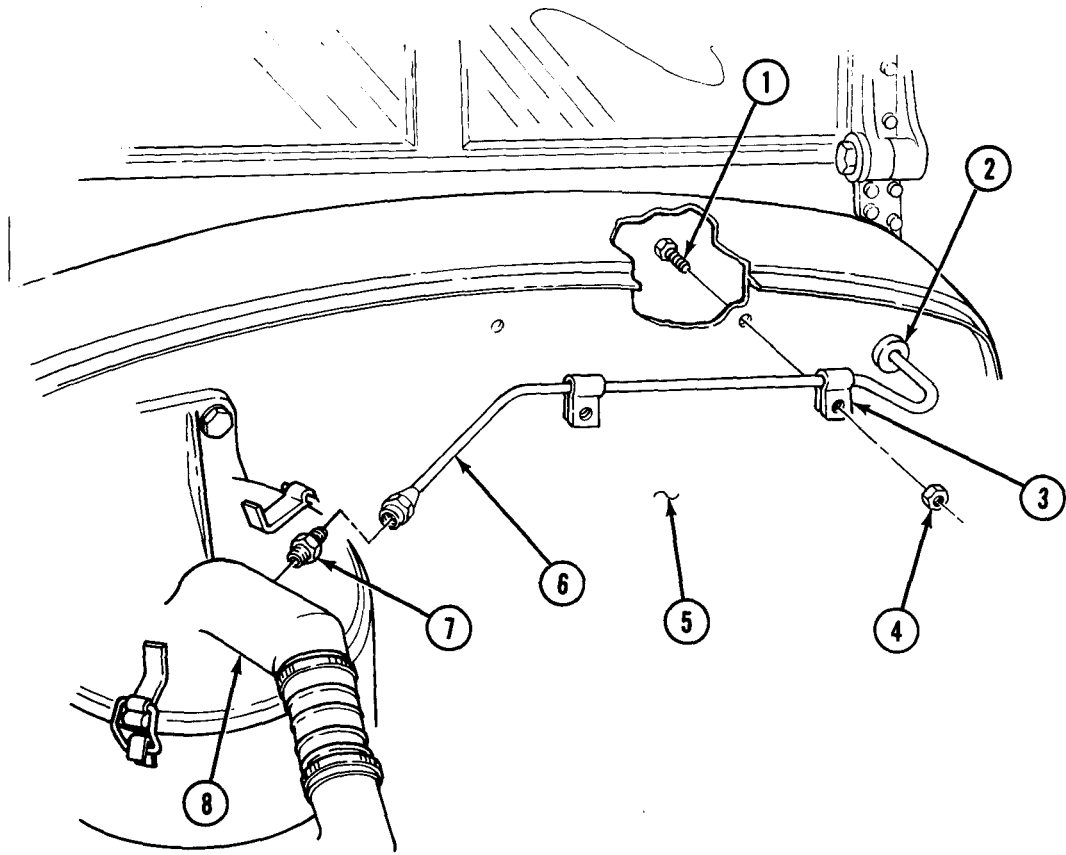

**Section V. TURBOCHARGER MAINTENANCE**

**3-17. TURBOCHARGER MAINTENANCE INDEX**

PARA. NO.	TITLE	PAGE NO.
3-18.	Turbocharger Oil Inlet Tube and Adapter Replacement	3-28
3-19.	Turbocharger Oil Drain Tube, Hose, and Adapter Replacement	3-30

**3-18. TURBOCHARGER OIL INLET TUBE AND ADAPTER REPLACEMENT**

This task covers:

**a. Removal**

**b. Installation**

**INITIAL SETUP:**

APPLICABLE MODELS

All

MATERIALS/PARTS

Gasket

Two lockwashers

Cap and plug set (Appendix C, Item 8)

Antiseize tape (Appendix C, Item 27)

Lubricating oil OE/HDO 30  
(Appendix C, Item 19)

REFERENCES (TM)

TM 9-2320-361-10

TM 9-2320-361-20P

EQUIPMENT CONDITION

- Parking brake set (TM 9-2320-361-10).
- Hood raised and secured (TM 9-2320-361-10).

**CAUTION**

Cover or plug all hoses, connections, and openings immediately after disconnection or component removal to prevent contamination. Remove all plugs prior to connection.

**a. Removal**

1. Remove oil inlet tube (3) from elbow (5) and oil inlet adapter (8).
2. Remove elbow (5) from engine (4).
3. Remove two screws (1), lockwashers (2), oil inlet adapter (8), and gasket (7) from turbocharger (6).  
Discard lockwashers (2) and gasket (7).

**b. Installation**

1. Install new gasket (7) and oil inlet adapter (8) on turbocharger (6) with two new lockwashers (2) and screws (1).
2. Add 2 oz. (59 ml) of new engine oil into oil inlet adapter (8).
3. Install elbow (5) on engine (4).
4. Install oil inlet tube (3) on elbow (5) and oil inlet adapter (8).

**3-18. TURBOCHARGER OIL INLET TUBE AND ADAPTER REPLACEMENT (Contd)**

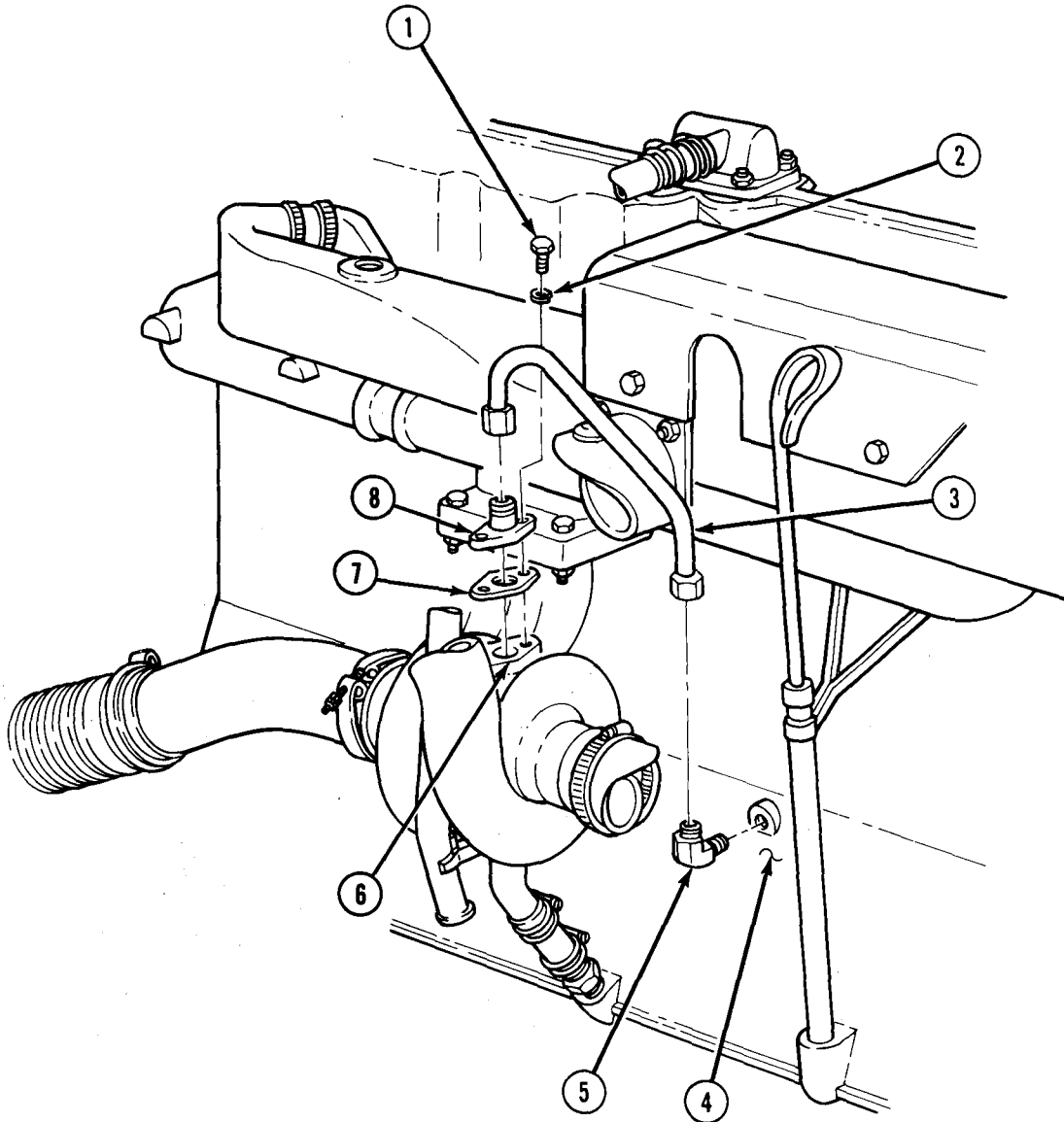

FOLLOW-ON TASK: Start engine (TM 9-2320-361-10) and check for oil leaks.

### 3-19. TURBOCHARGER OIL DRAIN TUBE, HOSE, AND ADAPTER REPLACEMENT

This task covers:

**a. Removal**

**b. Installation**

INITIAL SETUP:

APPLICABLE MODELS

All

REFERENCES (TM)

TM 9-2320-361-10

TM 9-2320-361-20P

MATERIALS/PARTS

Gasket

Two lockwashers

Antiseize tape (Appendix C, Item 27)

EQUIPMENT CONDITION

• Parking brake set (TM 9-2320-361-10).

• Hood raised and secured (TM 9-2320-361-10).

**a. Removal**

1. Remove two screws (7) and lockwashers (8) from breather tube (9), oil drain tube (2), and turbocharger (1). Discard lockwashers (8).
2. Loosen two clamps (6) and remove oil drain tube (2) and gasket (10) from turbocharger (1) and hose (4). Discard gasket (10).
3. Remove hose (4) and two clamps (6) from oil drain adapter (5).
4. Remove oil drain adapter (5) from engine (3).

**b. Installation**

**NOTE**

Male pipe threads must be wrapped with antiseize tape before installation.

1. Install oil drain adapter (5) on engine (3).
2. Install hose (4) and two clamps (6) on oil drain adapter (5). Do not tighten clamps (6).
3. Install oil drain tube (2) on hose (4).
4. Install new gasket (10), oil drain tube (2), and breather tube (9) on turbocharger (1) with two new lockwashers (8) and screws (7).
5. Tighten two clamps (6).

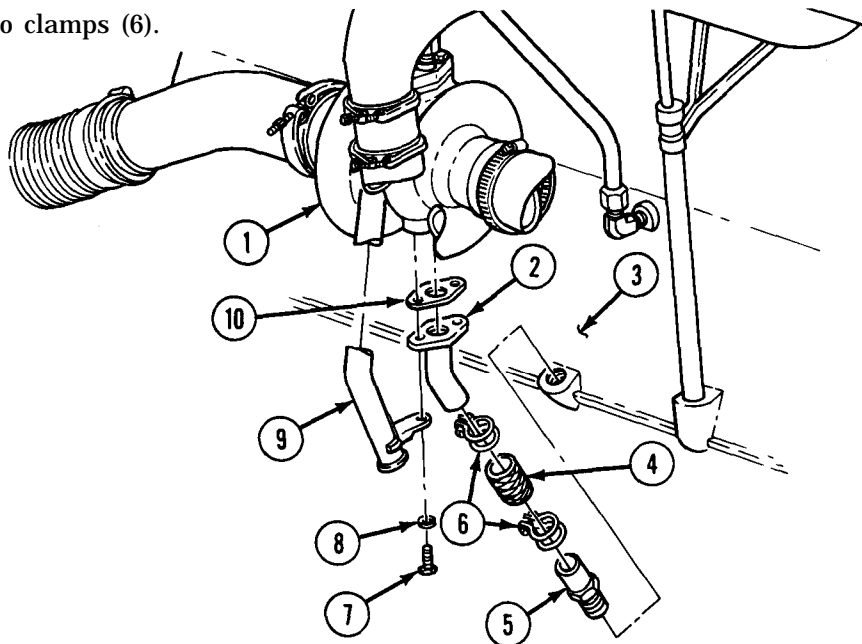

FOLLOW-ON TASK: Remove oil inlet tube and refill turbocharger (para. 3-18).

Section VI. FUEL SYSTEM MAINTENANCE

**3-20. GENERAL**

For tools and methods used to fabricate fuel system lines and tubes, refer to TM 9-243.

**3-21. FUEL SYSTEM MAINTENANCE INDEX**

PARA. NO.	TITLE	PAGE NO.
3-22.	Fuel Tank Filler Cap and Sleeve Replacement	3-31
3-23.	Fuel Pump (In-Tank) Fuse Replacement	3-33
3-24.	Fuel Tank Replacement	3-34
3-25.	Fuel Tank Replacement (M275A2)	3-38
3-26.	Fuel Pump (In-Tank) Maintenance	3-42
3-27.	Fuel Return Tees and Tubes Replacement	3-49
3-28.	Primary Fuel Filter Maintenance	3-50
3-29.	Secondary and Final Fuel Filter Testing and Maintenance	3-54
3-30.	Manifold Heater (Covered ) Replacement	3-60
3-31.	Manifold Heater (Uncovered ) Replacement	3-66

**3-22. FUEL TANK FILLER CAP AND SLEEVE REPLACEMENT**

This task covers:

**a. Removal**

**b. Installation**

**INITIAL SETUP:**

APPLICABLE MODELS

All

MATERIALS/PARTS

Gasket

REFERENCES (TM)

TM 9-2320-361-10

TM 9-2320-361-20P

EQUIPMENT CONDITION

Parking brake set (TM 9-2320-361-10).

GENERAL SAFETY INSTRUCTIONS

Diesel fuel is flammable. Do not perform this procedure near flames.

## 3-22. FUEL TANK FILLER CAP AND SLEEVE REPLACEMENT (Contd)

### a. Removal

#### WARNING

Diesel fuel is flammable. Do not perform fuel system procedures near open flame. Injury or death to personnel may result.

1. Remove fuel tank filler cap (2) from fuel tank (5) and disconnect chain (1) from sleeve (4).
2. Rotate sleeve (4) counterclockwise and remove sleeve (4) from fuel tank (5).
3. Remove gasket (3) from fuel tank filler cap (2). Discard gasket (3).

### b. Installation

1. Install new gasket (3) on fuel tank filler cap (2).
2. Install sleeve (4) on fuel tank (5) by rotating clockwise.
3. Connect chain (1) to sleeve (4), and install fuel tank filler cap (2) on fuel tank (5).

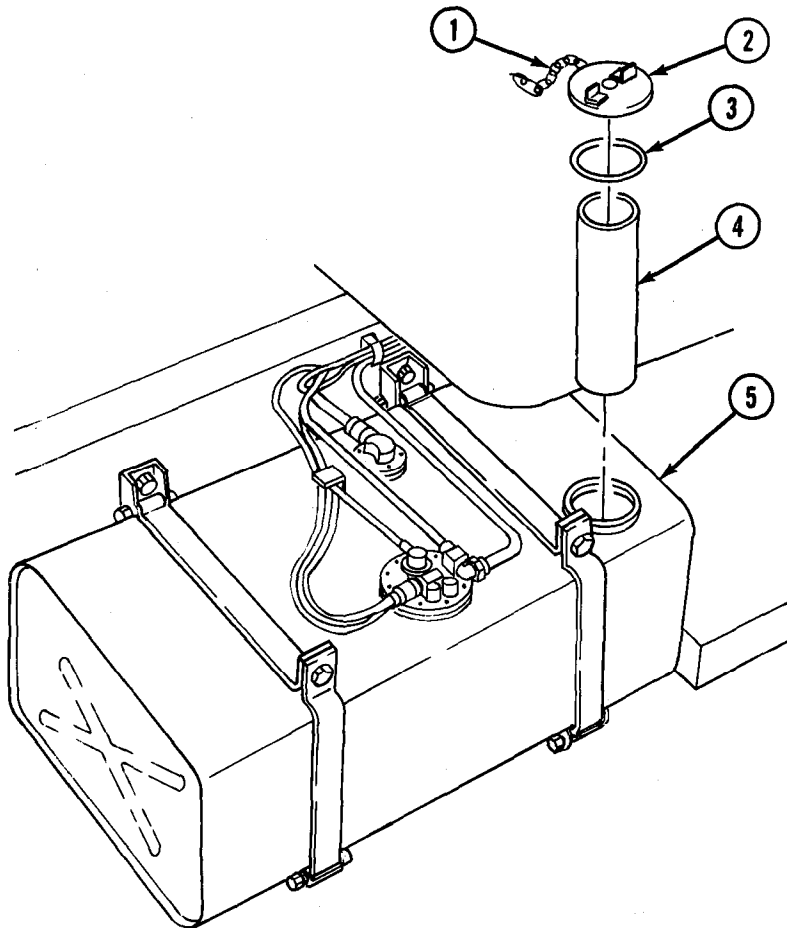

### 3-23. FUEL PUMP (IN-TANK) FUSE REPLACEMENT

This task covers:

#### a. Removal

#### b. Installation

#### INITIAL SETUP:

##### APPLICABLE MODELS

All

##### MATERIALS/PARTS

Three lockwashers

Gasket

Lead seal

Locktab

##### REFERENCES (TM)

TM 9-2320-361-10

TM 9-2320-361-20P

##### EQUIPMENT CONDITION

- Parking brake set (TM 9-2320-361-10).
- Battery ground cable disconnected (para. 4-48).
- Fuel tank removed (M275A2 only) (para. 3-25).

##### GENERAL SAFETY INSTRUCTIONS

Diesel fuel is flammable. Do not perform this task near open flame.

#### WARNING

Diesel fuel is flammable. Do not perform fuel system procedures near open flame. Injury or death to personnel may result.

#### a. Removal

1. Remove lead seal (4) from stud (8) by cutting wire (3). Discard wire (3) and lead seal (4).
2. Remove three nuts (2), lockwashers (5), locktab (6), and terminal cover (1) from fuel pump (9). Discard lockwashers (5) and locktab (6).
3. Remove screw (11) and disconnect wire (12) from terminal cover (1).
4. Remove gasket (10) from fuel pump (9). Discard gasket (10).
5. Remove fuse (7) from terminal cover (1).

#### b. Installation

1. Install 4-ampere fuse (7) on terminal cover (1).
2. Install gasket (10) on fuel pump (9) and connect wire (12) to terminal cover (1) with screw (11).
3. Install terminal cover (1) and new locktab (6) on fuel pump (9) with three new lockwashers (5) and nuts (2).
4. Install new seal wire (3) through one stud (8). Thread end of seal wire (3) back through lead seal (4) and fasten using lead seal press.

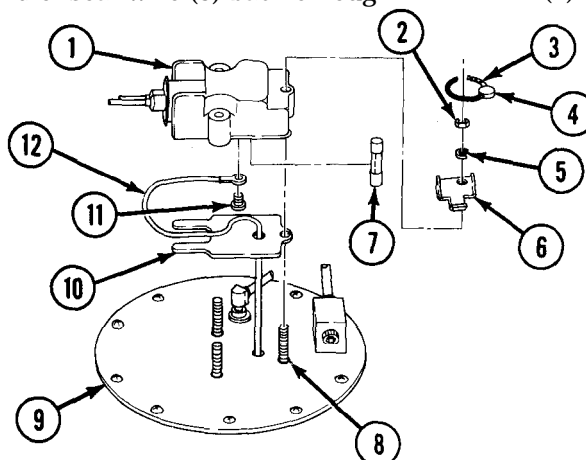
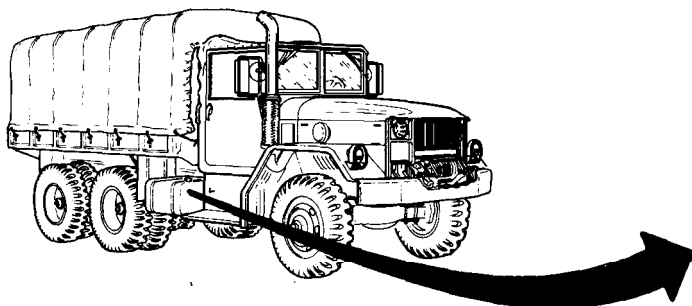

- FOLLOW-ON TASKS: :
- Connect battery ground cable (para. 4-48).
  - Install fuel tank (M275A2 only) (para. 3-25).
  - Start engine (TM 9-2320-361-10) and check fuel pump connections for leaks.



**3-24. FUEL TANK REPLACEMENT**

This task covers:

**a. Removal**

**b. Installation**

**INITIAL SETUP:**

**APPLICABLE MODELS**

All Except M275A2

**MATERIALS/PARTS**

Four locknuts  
Antiseize tape (Appendix C, Item 27)

**PERSONNEL REQUIRED**

Two

**REFERENCES (TM)**

TM 9-2320-361-10  
TM 9-2320-361-20P

**EQUIPMENT CONDITION**

- Battery ground cable disconnected (para. 4-48).
- Fuel tank filler cap and sleeve removed (para. 3-22).

**GENERAL SAFETY INSTRUCTIONS**

- Diesel fuel is flammable. Do not perform fuel system procedures near flames.
- Some vehicles have two separate wires and connectors. Connecting wires on wrong terminals may cause fuel to ignite, resulting in injury to personnel.

**a. Removal**

**WARNING**

Diesel fuel is flammable. Do not perform fuel system procedures near open flame. Injury or death to personnel may result.

**NOTE**

- Have drainage container ready to catch fuel.
- Fuel tanks on M342A2 vehicles have three retaining straps.

1. Drain fuel from fuel tank (4) by removing drainplug (8) from fuel tank (4).

**NOTE**

Male pipe threads must be wrapped with antiseize tape before installation.

2. Install drainplug (8) on fuel tank (4).
3. Disconnect fuel return tube (6) from elbow (5) and remove elbow (5) from fuel tank (4).

**WARNING**

Some vehicles have two separate wires and connectors. Mark wires for installation. Connecting wires on wrong terminals may cause fuel to ignite resulting in injury to personnel.

**CAUTION**

Perform steps 4 through 7 if removing fuel tank from M109A3, M185A3, and M756A2 series trucks.

4. Disconnect connector (16) from fuel pump (15).
5. Disconnect vent tube (18) from elbow (17) and remove elbow (17) from fuel pump (15).
6. Disconnect fuel supply tube (14) from fuel pump (15).
7. Disconnect connector (12) from sending unit (13).
8. Remove two locknuts (2) and screws (1) from two retaining straps (3) and (10). Discard locknuts (2).
9. Remove two locknuts (9), screws (11), and two retaining straps (10) from fuel tank hangers (7) and retaining straps (3). Discard locknuts (9).

3-24. FUEL TANK REPLACEMENT (Contd)

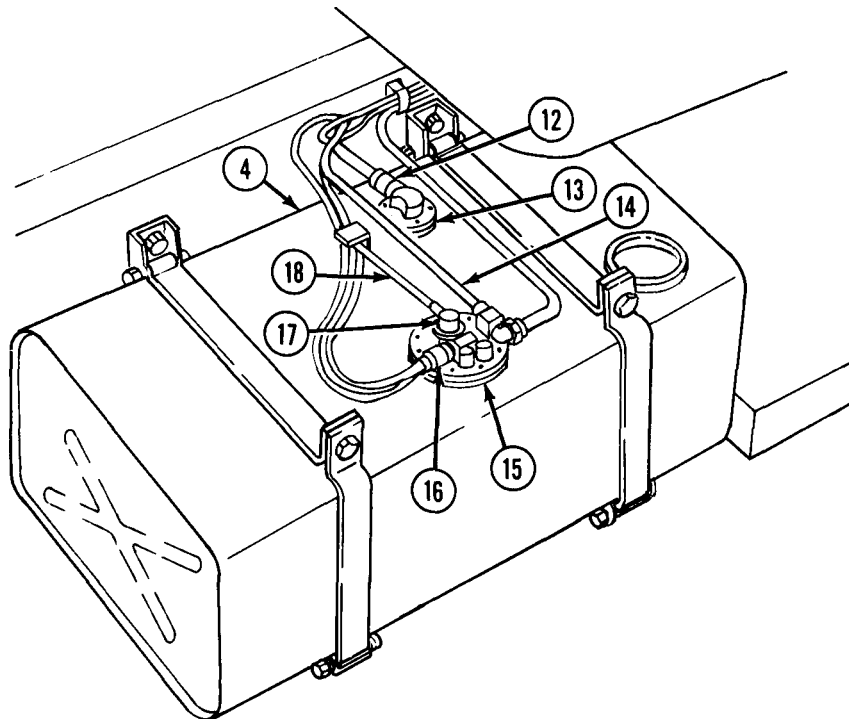
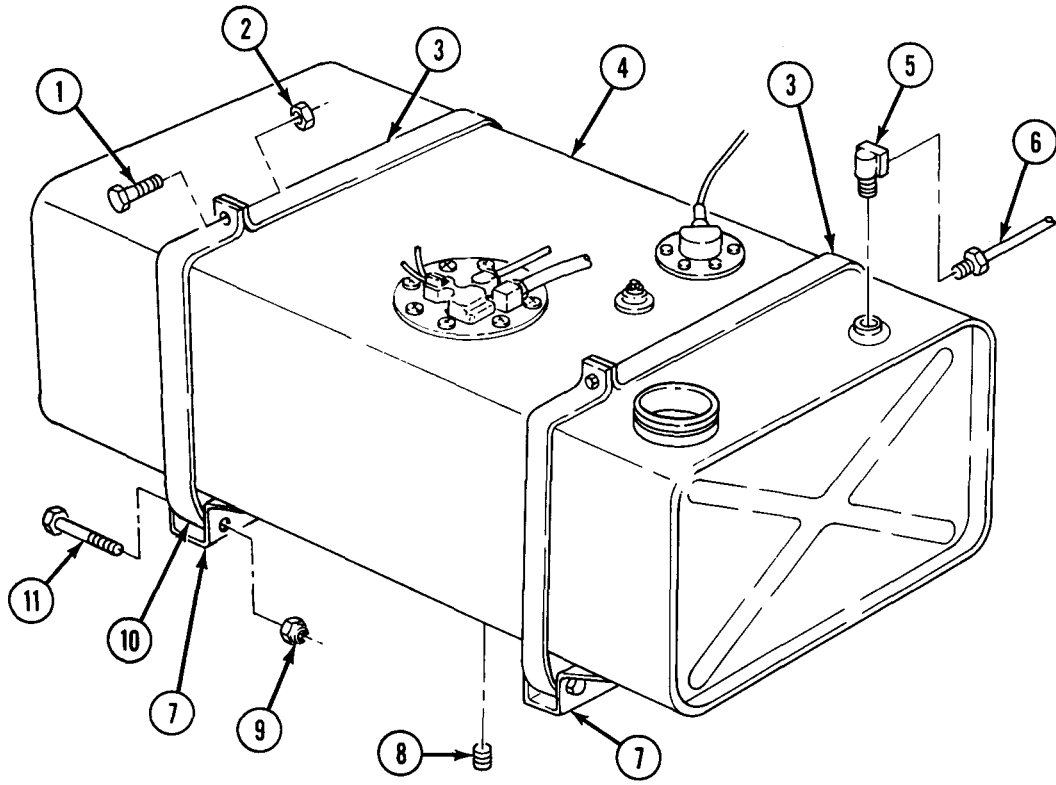

### 3-24. FUEL TANK REPLACEMENT (Contd)

#### NOTE

- Assistant will help with step 10.
- Perform steps 11 and 12 if removing fuel tank from M109A3, M185A3, and M756A2 series trucks.

10. Remove fuel tank (4) from two fuel tank hangers (7).
11. Remove fuel pump (15) from fuel tank (4) (para. 3-26).
12. Remove sending unit (13) from fuel tank (4) (para. 4-26).

#### b. Installation

#### NOTE

Perform steps 1 and 2 prior to installing fuel tank on M109A3, M185A3, and M756A2 series trucks.

1. Install sending unit (13) on fuel tank (4) (para. 4-26).
2. Install fuel pump (15) on fuel tank (4) (para. 3-26).

#### NOTE

Assistant will help with step 3.

3. Install fuel tank (4) on two fuel tank hangers (7).
4. Install two retaining straps (10) on fuel tank hangers (7) with two screws (11) and new locknuts (9).
5. Install two screws (1) and new locknuts (2) on two retaining straps (10) and (3).
6. Install elbow (5) on fuel tank (4).
7. Connect fuel return tube (6) to elbow (5).
8. Connect connector (12) to sending unit (13).
9. Connect fuel supply (14) to fuel pump (15).
10. Install elbow (17) on fuel pump (14).
11. Connect vent tube (18) to elbow (17).
12. Connect connector (16) to fuel pump (15).

3-24. FUEL TANK REPLACEMENT (Contd)

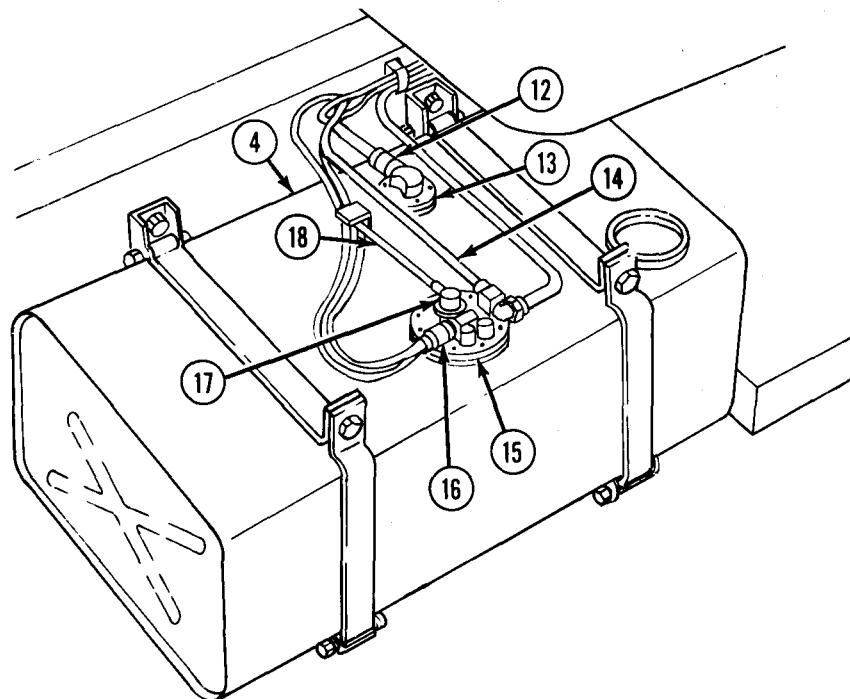
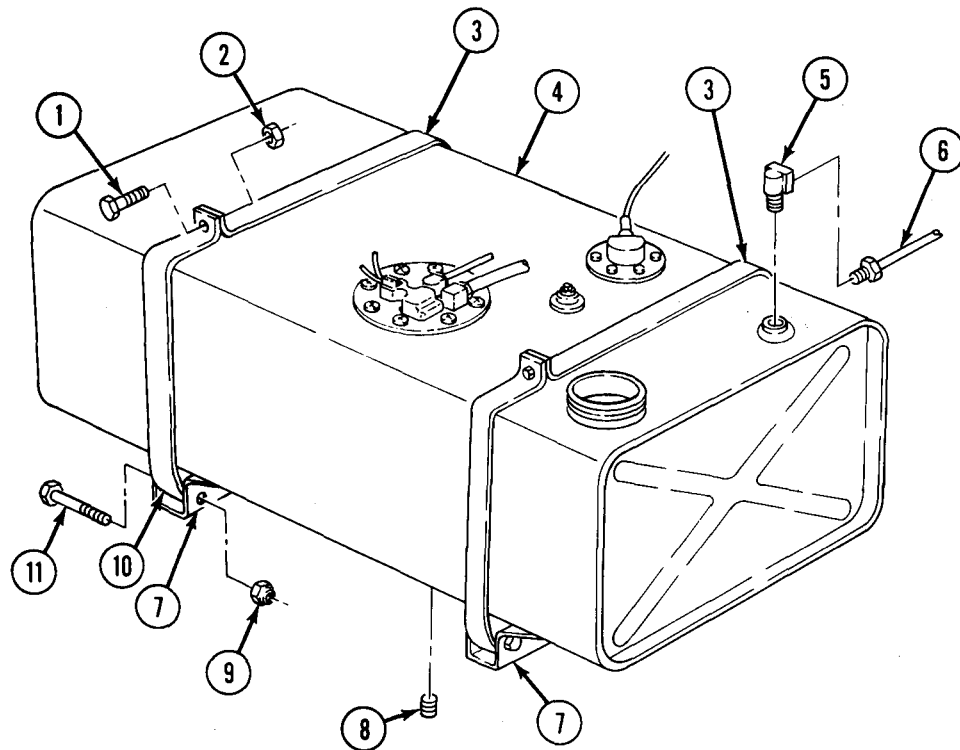

- FOLLOW-ON TASKS:
- Install fuel tank filler cap and sleeve (para. 3-22).
  - Connect battery ground cable (para. 4-48).
  - Fill fuel tank (TM 9-2320-361-10).
  - Start engine (TM 9-2320-361-10) and check for fuel leaks.

**3-25. FUEL TANK REPLACEMENT (M275A2)**

This task covers:

**a. Removal**

**b. Installation**

**INITIAL SETUP:**

APPLICABLE MODELS

M275A2

MATERIALS/PARTS

Six locknuts  
Antiseize tape (Appendix C, Item 27)

PERSONNEL REQUIRED

Two

REFERENCES (TM)

TM 9-2320-361-10  
TM 9-2320-361-20P

EQUIPMENT CONDITION

- Battery ground cable disconnected (para. 4-48).
- Wheels removed on left side of forward-rear axle (para. 9-2).
- Left front splash guard removed (para. 12-55).
- Rear cab mounts removed (para. 11-23).
- Fuel tank filler cap and sleeve removed (para. 3-22).

GENERAL SAFETY INSTRUCTIONS

- Diesel fuel is flammable. Do not perform fuel system procedures near flames.
- Some vehicles have two separate wires and connectors. Connecting wires on wrong terminals may cause fuel to ignite, resulting in injury to personnel.

**a. Removal**

**WARNING**

Diesel fuel is flammable. Do not perform fuel system procedures near open flame. Injury or death to personnel may result.

**NOTE**

Have drainage container ready to catch fuel.

1. Drain fuel from fuel tank (16) by removing drainplug (21) from fuel tank (16).

**NOTE**

Male pipe threads must be wrapped with antisiez tape before installation.

2. Install drain plug (21) on fuel tank (16).

**WARNING**

Some vehicles have two separate wires and connectors. Mark wires for installation. Connecting wires on wrong terminals may cause fuel to ignite, resulting in injury to personnel.

3. Disconnect connector (1) from fuel pump (19).
4. Disconnect wire (6) from fuel level sending unit (7).
5. Disconnect fuel supply tube (4) from elbow (18).
6. Disconnect vent tube (2) from elbow (3).
7. Disconnect fuel return tube (5) from elbow (17).
8. Remove three locknuts (8) and screws (10) from three side retaining straps (11), top retaining straps (9), and bracket (20). Discard locknuts (8).
9. Remove three locknuts (15), screws (12), and side retaining straps (11) from three fuel tank hangers (14). Discard locknuts (15).

### 3-25. FUEL TANK REPLACEMENT (M275A2) (Contd)

#### NOTE

Assistant will help with step 10.

10. Remove fuel tank (16) from three fuel tank hangers (14) and top retaining straps (9).
11. Remove three insulators (13) from fuel tank (16).
12. Remove fuel pump (19) (in-tank) (para. 3-26).
13. Remove fuel level sending unit (7) (para. 4-26).
14. Remove elbow (17) from fuel tank (16).

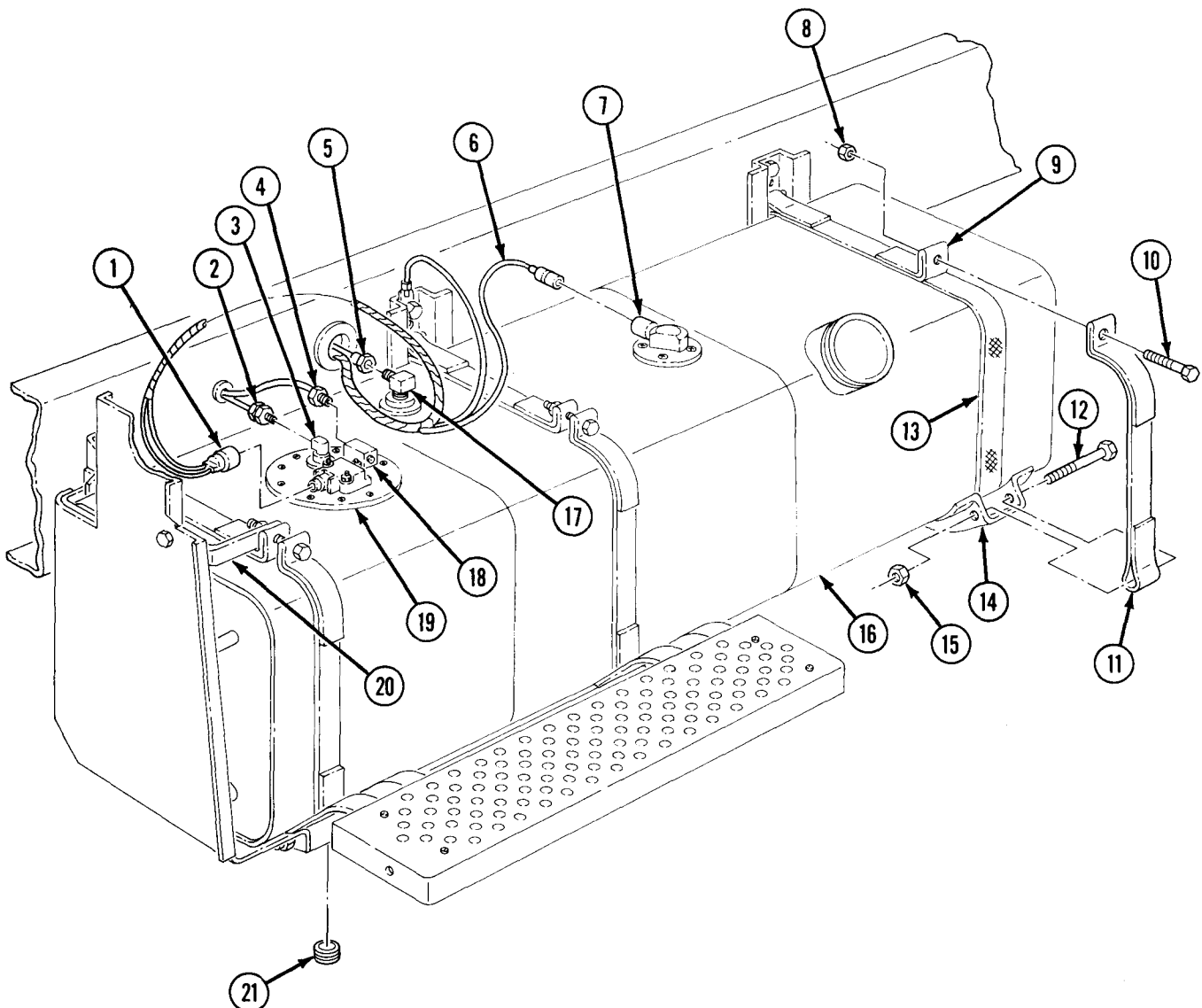

### 3-25. FUEL TANK REPLACEMENT (M275A2) (Contd)

#### b. Installation

#### NOTE

Male pipe threads must be wrapped with antiseize tape before installation.

1. Install elbow (17) on fuel tank (16).
2. Install fuel level sending unit (7) (para. 4-26).
3. Install fuel pump (19) (in-tank) (para. 3-26).
4. Install three insulators (13) on fuel tank (16).

#### NOTE

Assistant will help with step 5.

5. Aline three insulators (13) with fuel tank hangers (14) and install fuel tank (16) on three fuel tank hangers (14).

#### NOTE

Ensure insulators are in place between fuel tank retaining straps and fuel tank during fuel tank installation.

6. Install three side retaining straps (11) on fuel tank hangers (14) with three screws (12) and new locknuts (15).
7. Connect three side retaining straps (11) to top retaining straps (9) and bracket (20) with three screws (10) and new locknuts (8).
8. Connect fuel return tube (5) to elbow (17).
9. Connect vent tube (2) to elbow (3).
10. Connect fuel supply tube (4) to elbow (18).
11. Connect wire (6) to fuel level sending unit (7).

#### **WARNING**

Some vehicles have two separate wires and connectors. Connecting wires on wrong terminals may cause fuel to ignite, resulting in injury to personnel.

12. Connect connector (1) to fuel pump (19).

### 3-25. FUEL TANK REPLACEMENT (M275A2) (Contd)

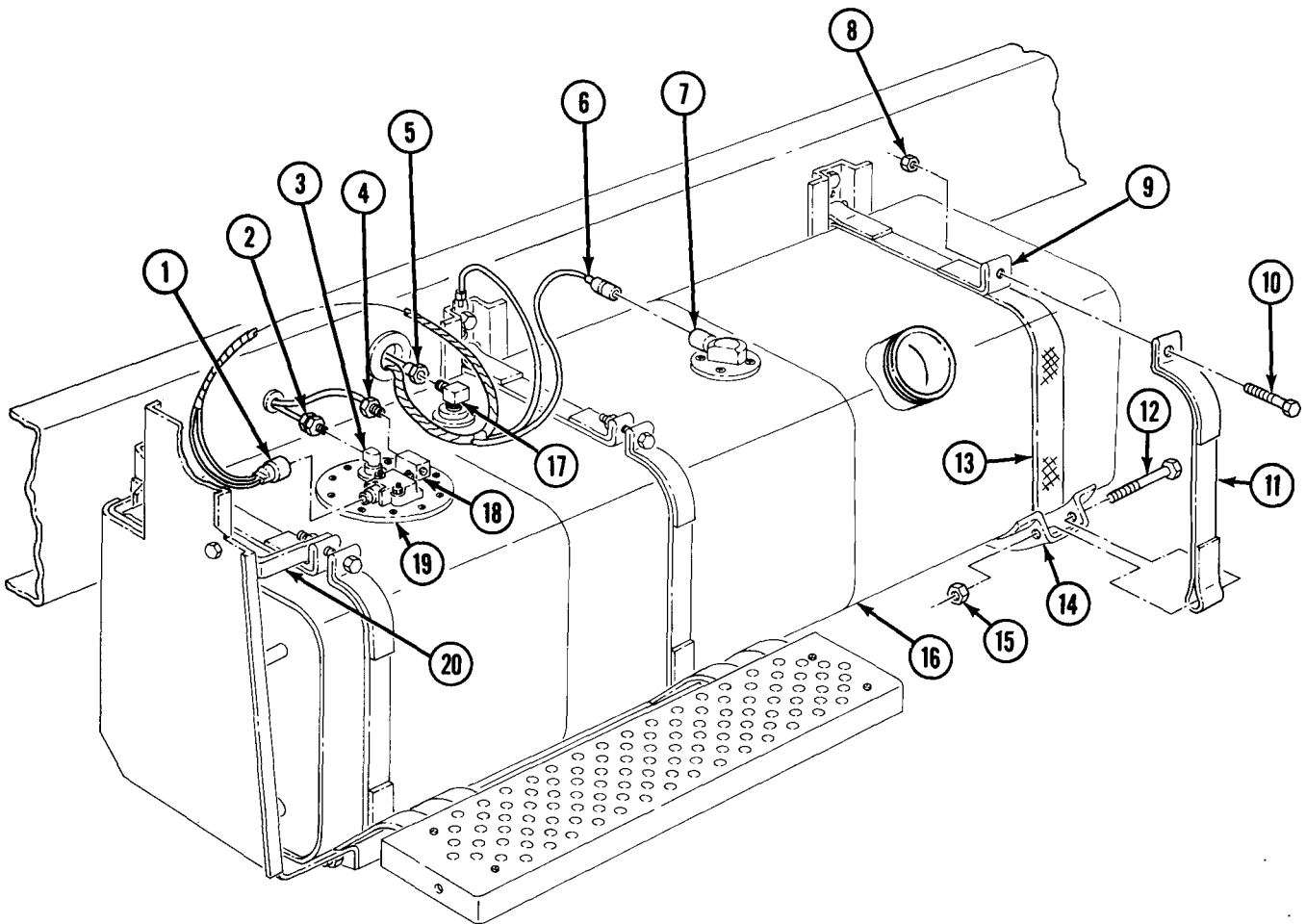

- FOLLOW-ON TASKS:**
- Install fuel tank filler cap and sleeve (para. 3-22).
  - Install rear cab mounts (para. 11-23).
  - Install left front splash guard (para. 12-55).
  - Install wheels on left side of forward-rear axle (para. 9-2).
  - Connect battery ground cable (para. 4-48).
  - Fill fuel tank (TM 9-2320-361-10).
  - Start engine (TM 9-2320-361-10) and check for fuel leaks.
  - Check operation of fuel gage (TM 9-2320-361-10).



**3-26. FUEL PUMP (IN-TANK) MAINTENANCE**

This task covers:

- |  |   |
|--|---|
| <p>a. Testing Fuel Pump Pressure<br/>                 b. Removal<br/>                 c. Disassembly</p> | <p>d. Cleaning and Inspection<br/>                 e. Assembly<br/>                 f. Installation</p> |
|--|---|

**INITIAL SETUP:**

APPLICABLE MODELS

All

SPECIAL TOOLS

Fuel pressure gage, NSN 4910-00-255-8673

MATERIALS/PARTS

- Nine lockwashers
- Three gaskets
- "O" ring
- Lead seal
- Locktab
- Antiseize tape (Appendix C, Item 27)

REFERENCES (TM)

- TM 9-2320-361-10
- TM 9-2320-361-20P

EQUIPMENT CONDITION

Parking brake set (TM 9-2320-361-10).

GENERAL SAFETY INSTRUCTIONS

- Diesel fuel is flammable. Do not perform this procedure near flames.
- Some vehicles have two separate wires and connectors. Connecting wires on wrong terminals may cause fuel to ignite, resulting in injury to personnel.

**a. Testing Fuel Pump Pressure**

**WARNING**

Diesel fuel is flammable. Do not perform fuel system procedures near open flame. Injury or death to personnel may result.

1. Disconnect fuel supply tube (3) from fuel pump (4).
2. Connect adapter (1) and fuel pressure gage (2) to fuel pump (4).

**CAUTION**

Starting engine may damage fuel pressure gage.

3. Turn accessory switch to ON position (TM 9-2320-361-10) to start fuel pump (4).
4. Read pressure on fuel pressure gage (2). If pressure reads at least 4 psi (27.6 kPa), operation of fuel pump (4) is satisfactory. Turn accessory switch to OFF position (TM 9-2320-361-10) and remove fuel pressure gage (2) and adapter (1) from fuel pump (4).
5. If fuel pressure gage (2) reads no pressure, inspect electrical connections and, if necessary, continue with task b. to replace fuel pump (4).

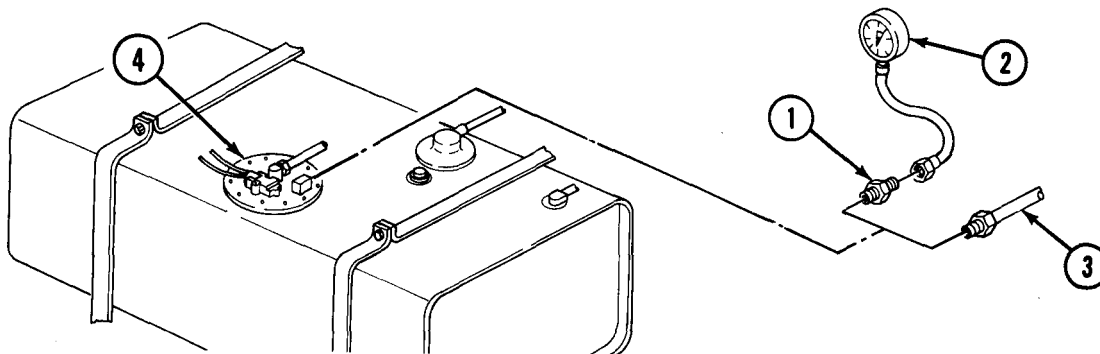

### 3-26. FUEL PUMP (IN-TANK) MAINTENANCE (Contd)

#### b. Removal

#### NOTE

Remove fuel tank from vehicles M109A3, M756A2, and M1858A3 (para. 3-24); for vehicle M256A2, refer to para. 3-25.

1. Disconnect battery cable (para. 4-48).

#### WARNING

Some vehicles have two separate wires and connectors. Mark wires for installation. Connecting wires on wrong terminals may cause fuel to ignite, resulting in injury to personnel.

2. Disconnect connector (10) from terminal cover (11).
3. Disconnect vent tube (7) from elbow (6) and remove elbow (6) from fuel pump assembly (4).
4. Disconnect fuel supply tube (3) from fuel pump assembly (4) if not already disconnected.
5. Remove ten screws (5), fuel pump (4), and gasket (8) from fuel tank (9). Discard gasket (8).
6. Cover opening in fuel tank (9) to prevent dirt and dust from entering.

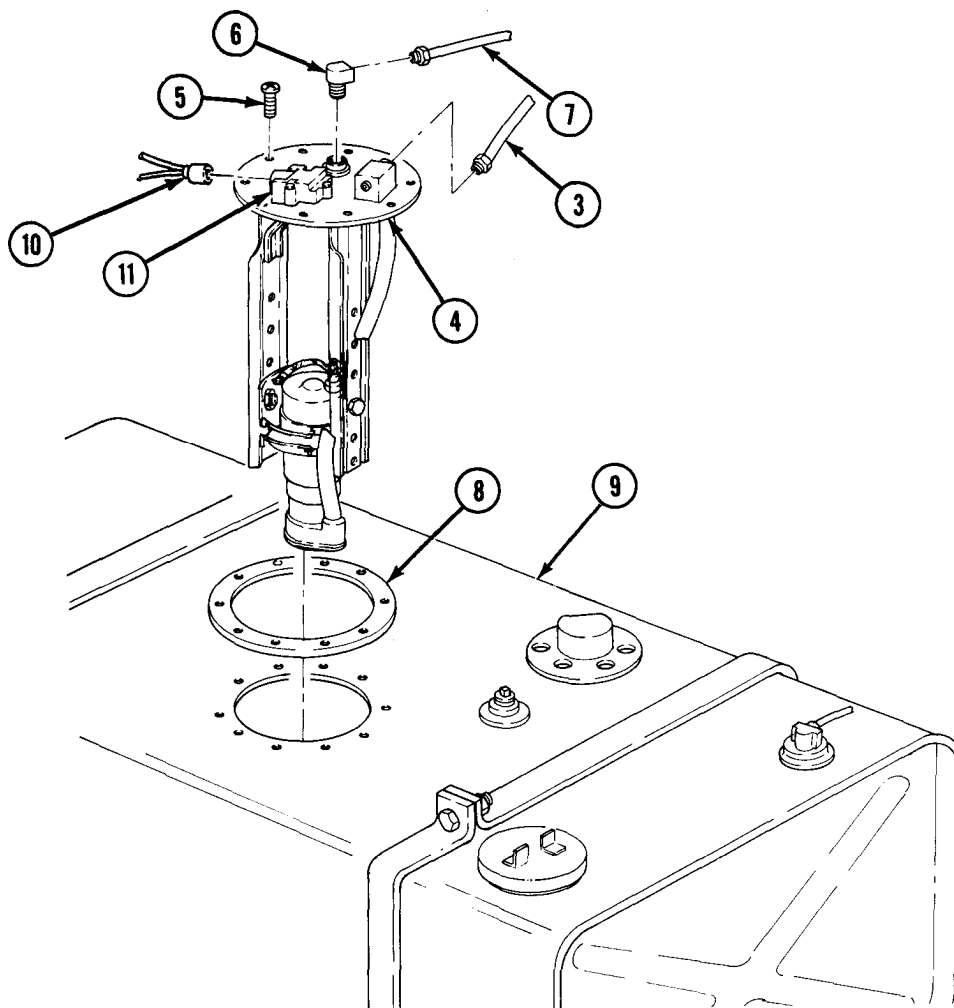

### 3-26. FUEL PUMP (IN-TANK) MAINTENANCE (Contd)

#### c. Disassembly

1. Remove lead seal (9) from stud (33) by cutting wire. Discard lead seal (9).
2. Remove three nuts (5), lockwashers (4), locktab (10), and terminal cover (3) from plate and bracket (32). Discard locktab (10).
3. Remove screw (1) and disconnect pump wire (27) from terminal cover (3).
4. Remove fuse (2) from terminal cover (3).
5. Remove nut (6), lockwasher (7), fuel pump wire (27), wire retainer (26), and gasket (8) from plate and bracket (32). Discard lockwasher (7) and gasket (8).
6. Remove gasket (30) and recessed washer (29) from wire retainer (26). Discard gasket (30).

#### NOTE

Note location of mounting hardware on plate and bracket for proper installation.

7. Remove nut (15), washer (16), screw (14), and clamp (31) from wire retainer (26) and plate and bracket (32).
8. Remove pump (25) from clamp assembly (28).
9. Remove two nuts (15), washers (16), screws (14), and clamp assembly (28) from plate and bracket (32).
10. Remove two nuts (23), screws (20), four lockwashers (21), and ground strap (22) from pump (25) and clamp assembly (28). Discard lockwashers (21).
11. Remove elbow (11) from plate and bracket (32).
12. Remove hose assembly (19), nut (18), lockwasher (17), "O" ring (13), and fitting (12) from plate and bracket (32). Discard lockwasher (17) and "O" ring (13).
13. Remove clamp (24) and hose assembly (19) from pump (25).

3-26. FUEL PUMP (IN-TANK) MAINTENANCE (Contd)

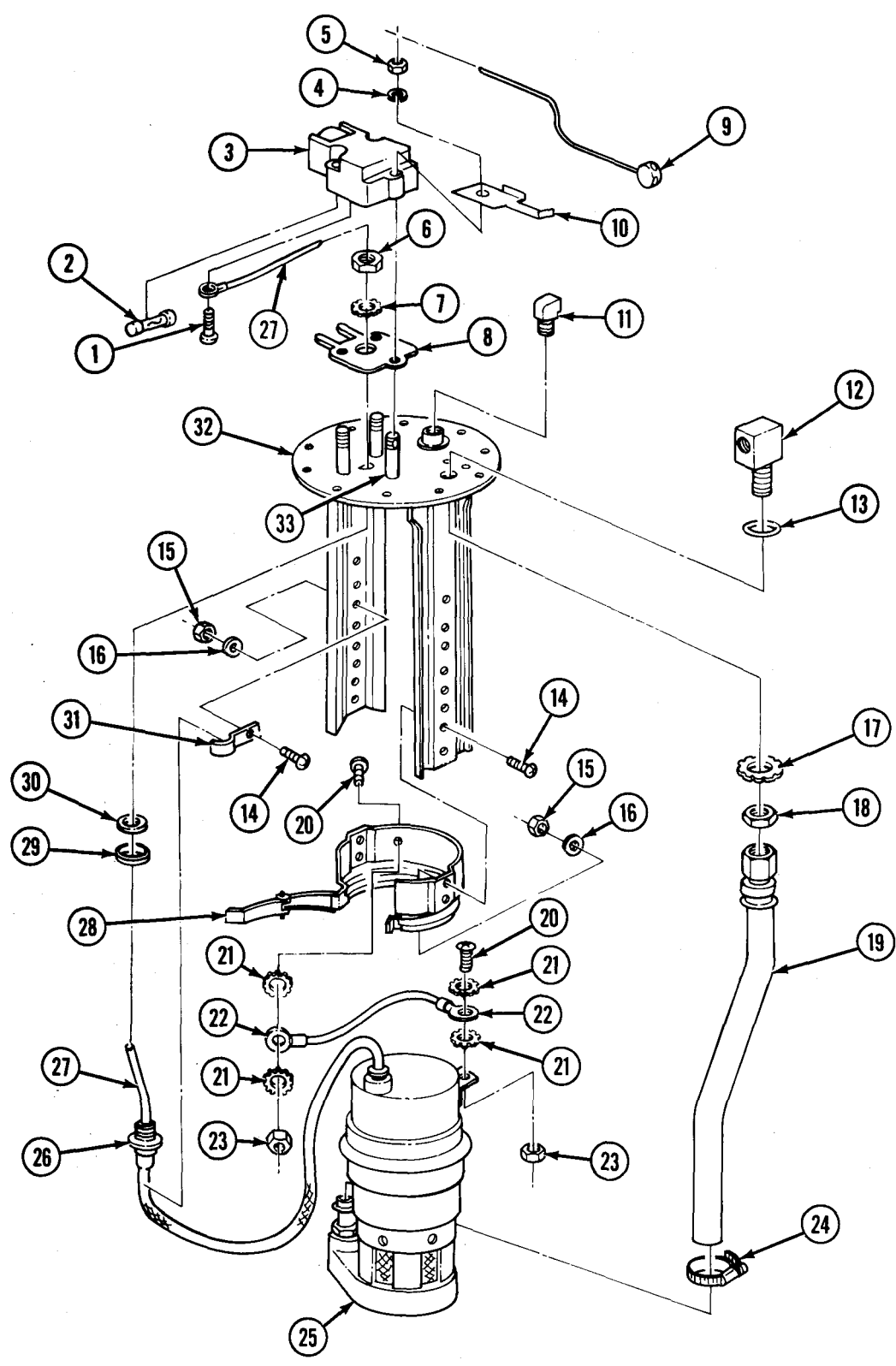

### 3-26. FUEL PUMP (IN-TANK) MAINTENANCE (Contd)

#### d. Cleaning and Inspection

Clean and inspect all fuel pump assembly parts for cracks, holes, and stripped threads. Replace damaged parts.

#### e. Assembly

1. Install ground strap (22) on pump (25) and clamp assembly (28) with four new lockwashers (21), two screws (20), and nuts (23).
2. Install hose assembly (19) on pump (25) with clamp (24).
3. Install new "O" ring (13) and fitting (12) on plate and bracket (32) with new lockwasher (17) and nut (18).

**NOTE**

Male pipe threads must be wrapped with antiseize tape before installation.

4. Install hose assembly (19) on fitting (12).
5. Install elbow (11) on plate and bracket (32).

**NOTE**

Before installing pump, measurement "A" must be 14.1 in. (36 cm) for model M275A2. For all other models, measurement must be 15.1 in. (38.4 cm).

6. Install pump (25) on clamp assembly (28) and position pump (25) up or down in plate and bracket (32) to give correct measurement.
7. Remove pump (25) from clamp assembly (28) and install clamp assembly (28) on plate and bracket (32) with two screws (14), washers (16), and nuts (15).
8. Install pump (25) on clamp assembly (28).
9. Install clamp (31) on wire retainer (26) with screw (14), washer (16), and nut (15).
10. Install new gasket (8) on plate and bracket (32) and position fuel pump wire (27) through center hole in plate and bracket (32) and new gasket (8).
11. Install recessed washer (29), new gasket (30), and wire retainer (26) on plate and bracket (32) with new lockwasher (7) and nut (6).
12. Install fuse (2) on terminal cover (3).
13. Install fuel pump wire (27) on terminal cover (3) with screw (1).
14. Install terminal cover (3) and new locktab (10) on plate and bracket (32) and gasket (8) with three new lockwashers (4) and nuts (5).
15. Install new lead seal (9) on stud (33) with lead seal press.

**3-26. FUEL PUMP (IN-TANK) MAINTENANCE (Contd)**

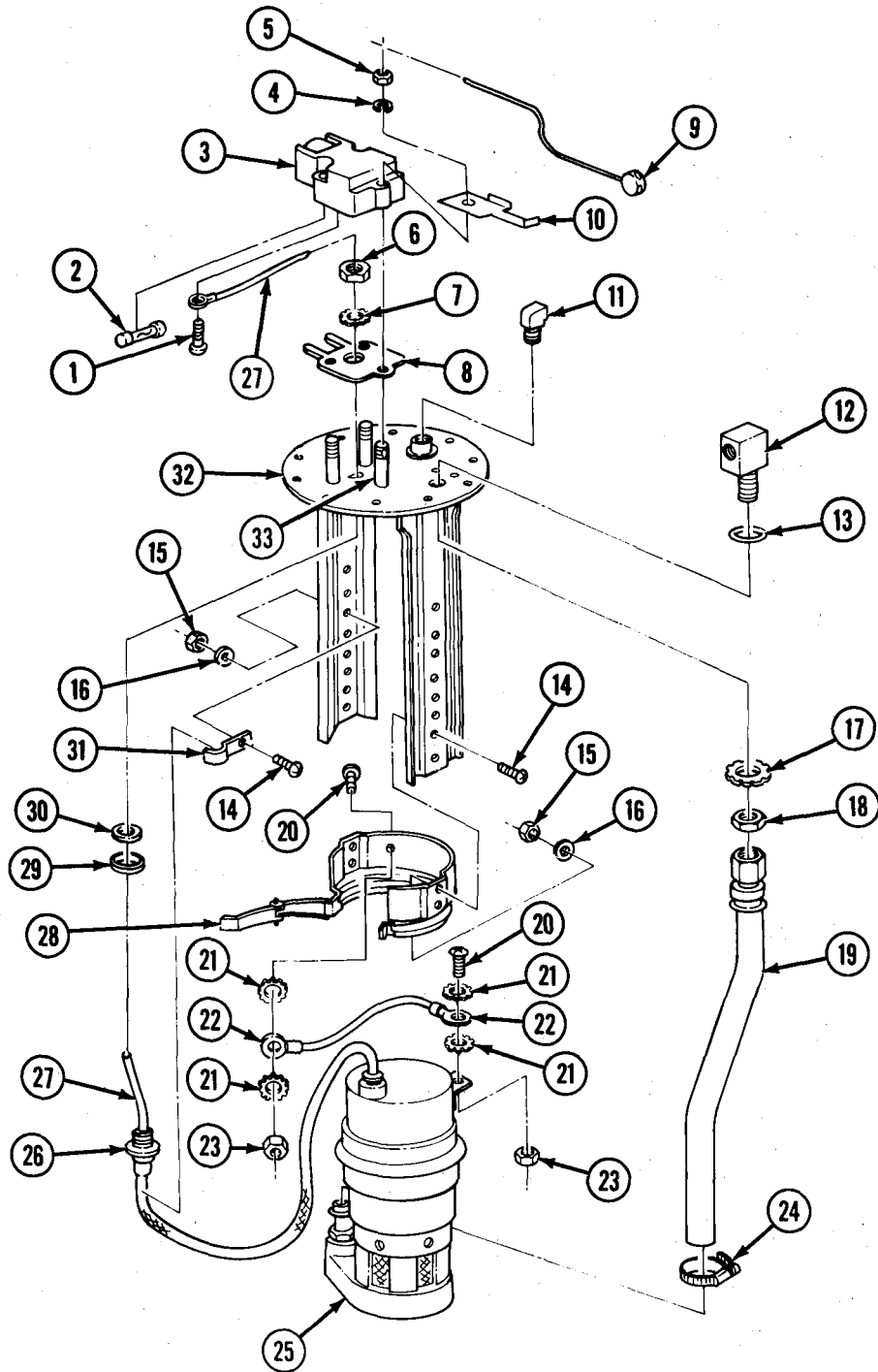

**3-26. FUEL PUMP (IN-TANK) MAINTENANCE (Contd)**

**f. Installation**

**NOTE**

- If new fuel pump is to be installed, measurement "A" must be 14.1 in. (36 cm) for model M275A2. For all other models, measurement must be 15.1 in. (38.4 cm).
- If necessary to adjust fuel pump length, perform steps 1 through 5.

1. Remove pump (8) from clamp (12).
2. Remove two nuts (11), washers (10), and screws (7) from clamp (12) and fuel pump bracket (6).
3. Install pump (8) on clamp (12) and position pump (8) up or down in fuel pump bracket (6) to give correct measurement.
4. Remove pump (8) from clamp (12) and install two screws (7), washers (10), and nuts (11) on fuel pump bracket (6) and clamp (12).
5. Install pump (8) in clamp (12).
6. Install new gasket (9) and fuel pump assembly (5) on fuel tank (13) with ten screws (1).
7. Install fuel tank (para. 3-25 for M275A2 or para. 3-24 for M109A3, M185A3, or M756A2).

**NOTE**

Male pipe threads must be wrapped with antiseize tape before installation.

8. Connect fuel supply tube (4) to fuel pump assembly (5).
9. Install elbow (2) on fuel pump assembly (5) and connect vent tube (3) to elbow (2).
10. Connect connector (15) to terminal cover (14).

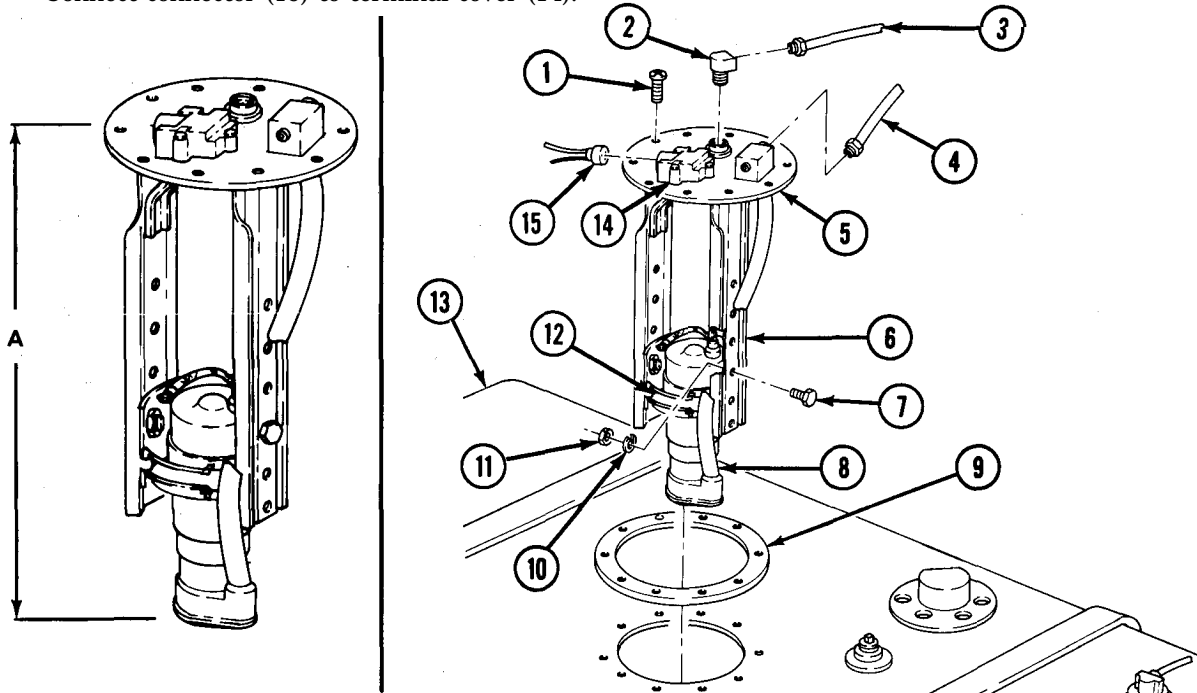

- FOLLOW-ON TASKS:**
- Connect battery ground cable (para. 4-48).
  - Start engine (TM 9-2320-361-10) and check operation of fuel pump.
  - Check for fuel leaks.

### 3-27. FUEL RETURN TEES AND TUBES REPLACEMENT

This task covers:

#### a. Removal

#### b. Installation

INITIAL SETUP:

#### APPLICABLE MODELS

All

#### REFERENCES (TM)

TM 9-2320-361-10

TM 9-2320-361-20P

#### EQUIPMENT CONDITION

- Parking brake set (TM 9-2320-361-10).
- Hood raised and secured (TM 9-2320-361-10).
- Battery ground cable disconnected (para. 4-48).

#### GENERAL SAFETY INSTRUCTIONS

Diesel fuel is flammable. Do not perform this task near open flames.

#### a. Removal

#### WARNING

- Diesel fuel is flammable. Do not perform fuel system procedures near open flames. Injury or death to personnel may result.
- Before performing fuel system procedure, allow engine to cool. Failure to do so may result in injury or death to personnel.

#### NOTE

All fuel return tees and tubes are replaced the same way.

1. Loosen two tube nuts (2) on fuel return tube (3), injector nozzle return tee (1), and elbow (4).
2. Remove tube (3) and two tube nuts (2) from injector nozzle return tee (1) and elbow (4).
3. Remove elbow (4) from injector nozzle (6).
4. Disconnect tube nut (7) from injector nozzle return tee (1) and remove injector nozzle return tee (1) from injector nozzle (5).
5. Cut new tube (3) to same length as old tube (3). Discard old tube (3).

#### b. Installation

1. Install injector nozzle return tee (1) on injector nozzle (5) and connect tube nut (7) to tee (1).
2. Install elbow (4) on injector nozzle (6).
3. Install new tube (3) on injector nozzle tee (1) and elbow (4) with two tube nuts (2).

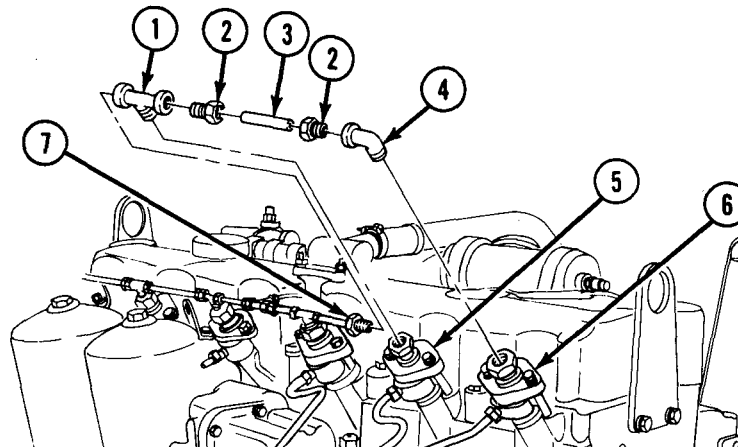

- FOLLOW-ON TASKS:
- Connect battery ground cable (para. 4-48).
  - Start engine (TM 9-2320-361-10) and check for fuel leaks.



### 3-28. PRIMARY FUEL FILTER MAINTENANCE

This task covers:

- a. Draining
- b. Filter Housing Removal
- c. Filter Removal

- d. Cleaning and Inspection
- e. Filter Installation
- f. Filter Housing Installation

#### INITIAL SETUP:

##### APPLICABLE MODELS

All

##### MATERIALS/PARTS

Six lockwashers  
 Two locknuts  
 Three gaskets  
 Filter element  
 Drycleaning solvent (Appendix C, Item 26)

##### REFERENCES (TM)

TM 9-2320-361-10  
 TM 9-2320-361-20P

##### EQUIPMENT CONDITION

Parking-brake set (TM 9-2320-361-10).  
 Hood raised and secured (TM 9-2320-361-10).  
 Battery ground cable disconnected (para. 4-48).

##### GENERAL SAFETY INSTRUCTIONS

Diesel fuel is flammable. Do not perform this procedure near flames.  
 Keep fire extinguisher nearby when using drycleaning solvent.

#### a. Draining

#### WARNING

Diesel fuel is flammable. Do not perform fuel system procedures near open flame. Injury or death to personnel may result.

#### NOTE

Have drainage container ready to catch fuel.

1. Open draincock (11) to drain fuel from primary fuel filter (1).
2. Close draincock (11).

#### b. Filter Housing Removal

1. Disconnect fuel lines (6) and (12) from connector (3) and elbow (13).
2. Remove two locknuts (9), washer (10), lockwasher (4), two screws (2), lockwasher (4), ground wire (5), bracket (7), and primary fuel filter (1) from frame (8) and bracket (7). Discard locknuts (9) and lockwashers (4).
3. Remove four screws (15), lockwashers (14), and bracket (7) from filter head (16). Discard lockwashers (14).
4. Remove elbow (13), connector (17), and connector (3) from filter head (16).

3-28. PRIMARY FUEL FILTER MAINTENANCE (Contd)

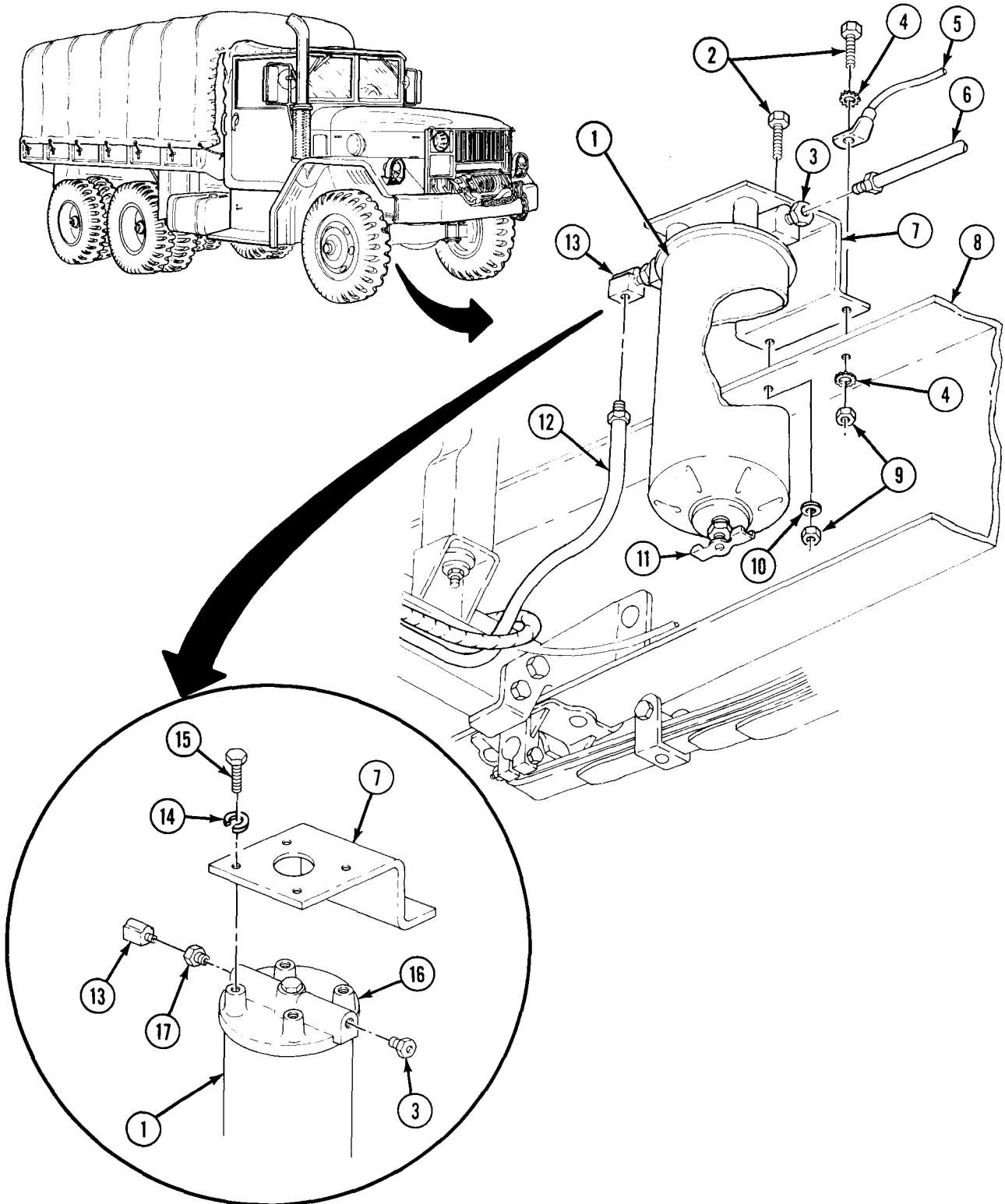

### 3-28. PRIMARY FUEL FILTER MAINTENANCE (Contd)

#### c. Filter Removal

1. Remove sleeve nut (1), gasket (2), filter head (3), and gasket (4) from filter housing (11). Discard gaskets (2) and (4).
2. Remove filter element (5) from filter housing (11). Discard filter element (5).
3. Remove cup (6), gasket (7), washer (8), spring (9), and washer (10) from filter housing (11). Discard gasket (7).

#### NOTE

Perform step 4 if draincock is damaged.

4. Remove draincock (12) from filter housing (11).

#### d. Cleaning and Inspection

#### WARNING

Drycleaning solvent is flammable and will not be used near open flame. Use only in well-ventilated places. Failure to do so may result in injury to personnel.

1. Clean all components with drycleaning solvent and dry with lint-free cloth.
2. Inspect components for stripped threads, burrs, and scratches on mating surfaces.

#### e. Filter Installation

1. Install draincock (12) on filter housing (11).
2. Install washer (10), spring (9), washer (8), new gasket (7), and cup (6) on filter housing (11).
3. Install new filter element (5), new gasket (4), filter head (3), and new gasket (2) on filter housing (11) with sleeve nut (1). Tighten sleeve nut (1) 15 lb-ft (20.3 N·m).

#### f. Filter Housing Installation

1. Install connector (16), connector (17), and elbow (18) on primary fuel filter head (3).
2. Install bracket (15) to primary fuel filter head (3) with four new lockwashers (13) and screws (14).
3. Install bracket (15) and ground strap (21) on frame (26) with two screws (19), washer (24), two new lockwashers (20), and new locknuts (23).
4. Connect fuel lines (22) and (25) to connector (16) and elbow (18).

**3-28. PRIMARY FUEL FILTER MAINTENANCE (Contd)**

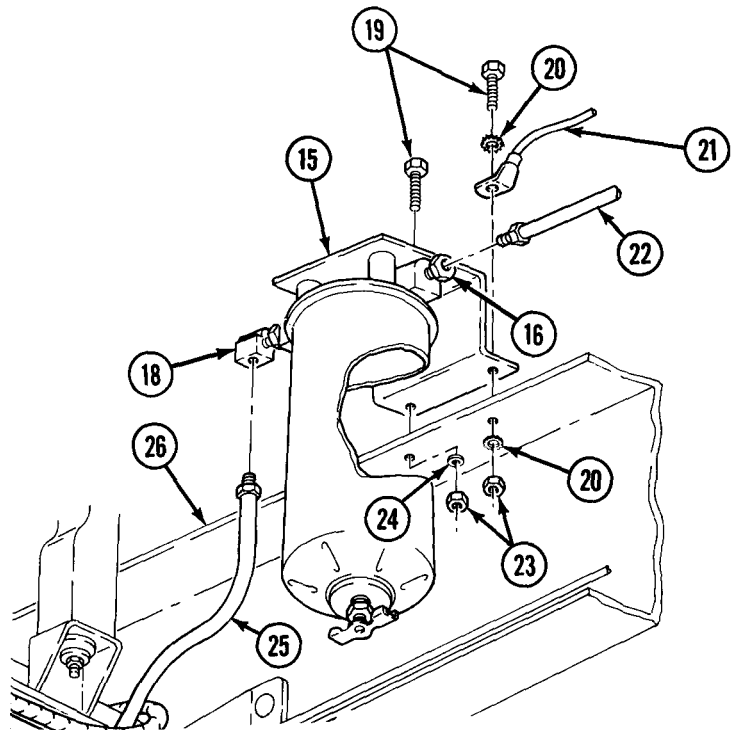
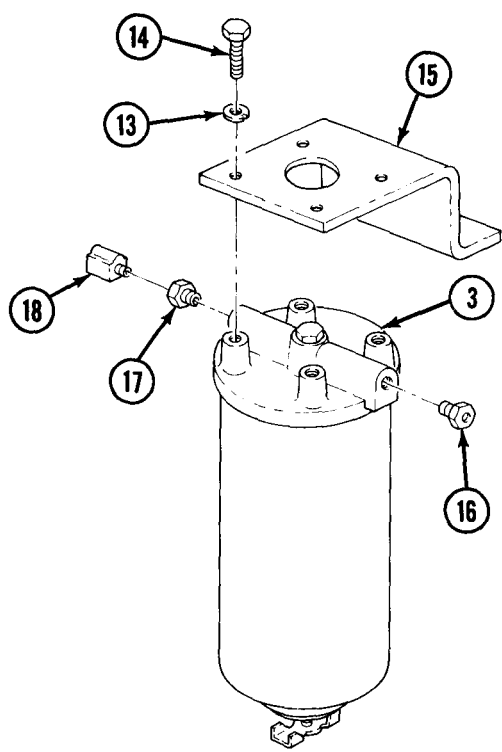
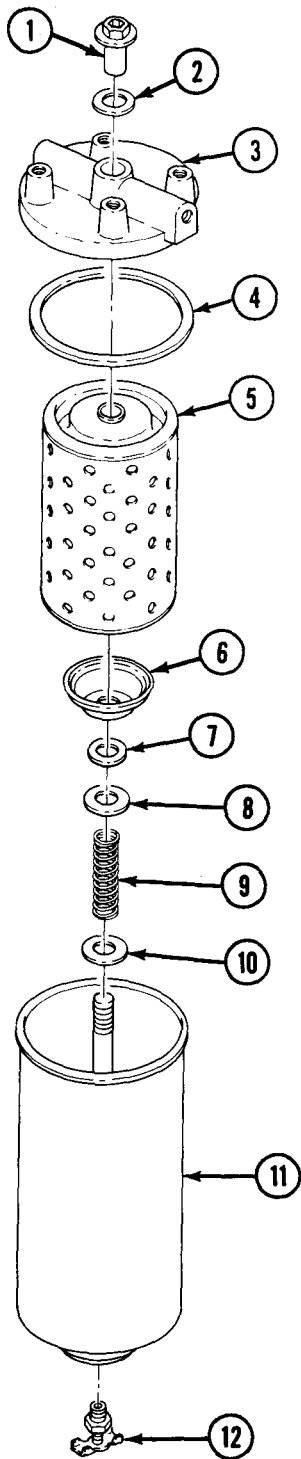

- FOLLOW-ON TASKS:**
- Connect battery ground cable (para. 4-48).
  - Bleed air from fuel system at secondary and final fuel filter (para. 3-28).
  - Start engine (TM 9-2320-361-10) and check for fuel leaks.

**3-29. SECONDARY AND FINAL FUEL FILTERS TESTING AND MAINTENANCE**

This task covers:

- |  |  |
|--|--|
| <ul style="list-style-type: none"> <li>a. Testing Fuel Pressure</li> <li>b. Draining</li> <li>c. Fuel Filter Head, Secondary, and Final Fuel Filters Removal</li> <li>d. Fuel Filters Removal</li> </ul> | <ul style="list-style-type: none"> <li>e. Cleaning and Inspection</li> <li>f. Fuel Filters Installation</li> <li>g. Fuel Filter Head, Secondary, and Final Fuel Filters Installation</li> <li>h. Bleeding Air</li> </ul> |
|--|--|

**INITIAL SETUP:**

APPLICABLE MODELS

All

TEST EQUIPMENT

Fuel pressure gage, NSN 4910-00-225-8673

MATERIALS/PARTS

- Three lockwashers
- Four washers
- Six gaskets
- Two filter elements
- Two cotter pins
- Rag (Appendix C, Item 21)
- Drycleaning solvent (Appendix C, Item 26)

REFERENCES (TM)

- TM 9-2320-361-10
- TM 9-2320-361-20P

EQUIPMENT CONDITION

- Parking brake set (TM 9-2320-361-10).
- Hood raised and secured (TM 9-2320-361-10).

GENERAL SAFETY INSTRUCTIONS

- Diesel fuel is flammable. Do not perform fuel system procedures near flames.
- Keep fire extinguisher nearby when using drycleaning solvent.

**a. Testing Fuel Pressure**

**WARNING**

Diesel fuel is flammable. Do not perform fuel system procedures near open flame. Injury or death to personnel may result.

**NOTE**

Fuel filters may have either one or two bleeder valves. Remove only one bleeder valve for testing fuel pressure.

1. Remove bleeder valve (1) or (4) from top of fuel filter head (5).
2. Install adapter (3) and fuel pressure gage (2).

**CAUTION**

Do not start engine. Starting engine may damage fuel pressure gage.

3. Turn accessory switch to ON position (TM 9-2320-361-10) to start fuel pump.
4. Read pressure on fuel pressure gage (2). If pressure reads at least 2 psi (13.8 kPa), condition of all fuel filters is satisfactory. If not, turn accessory switch to OFF position (TM 9-2320-361-10) and inspect for damaged fuel supply tubes (9) and, if necessary, replace primary fuel filter (para. 3-28). If pressure is still not at least 2 psi (13.8 kPa), continue with task b. to replace secondary and final fuel filter.

### 3-29. SECONDARY AND FINAL FUEL FILTERS TESTING AND MAINTENANCE (Contd)

#### NOTE

Have drainage container ready to catch fuel.

1. Open two draincocks (7) to drain fuel from secondary fuel filter housing (8) and final fuel filter housing (6).
2. Close two draincocks (7).

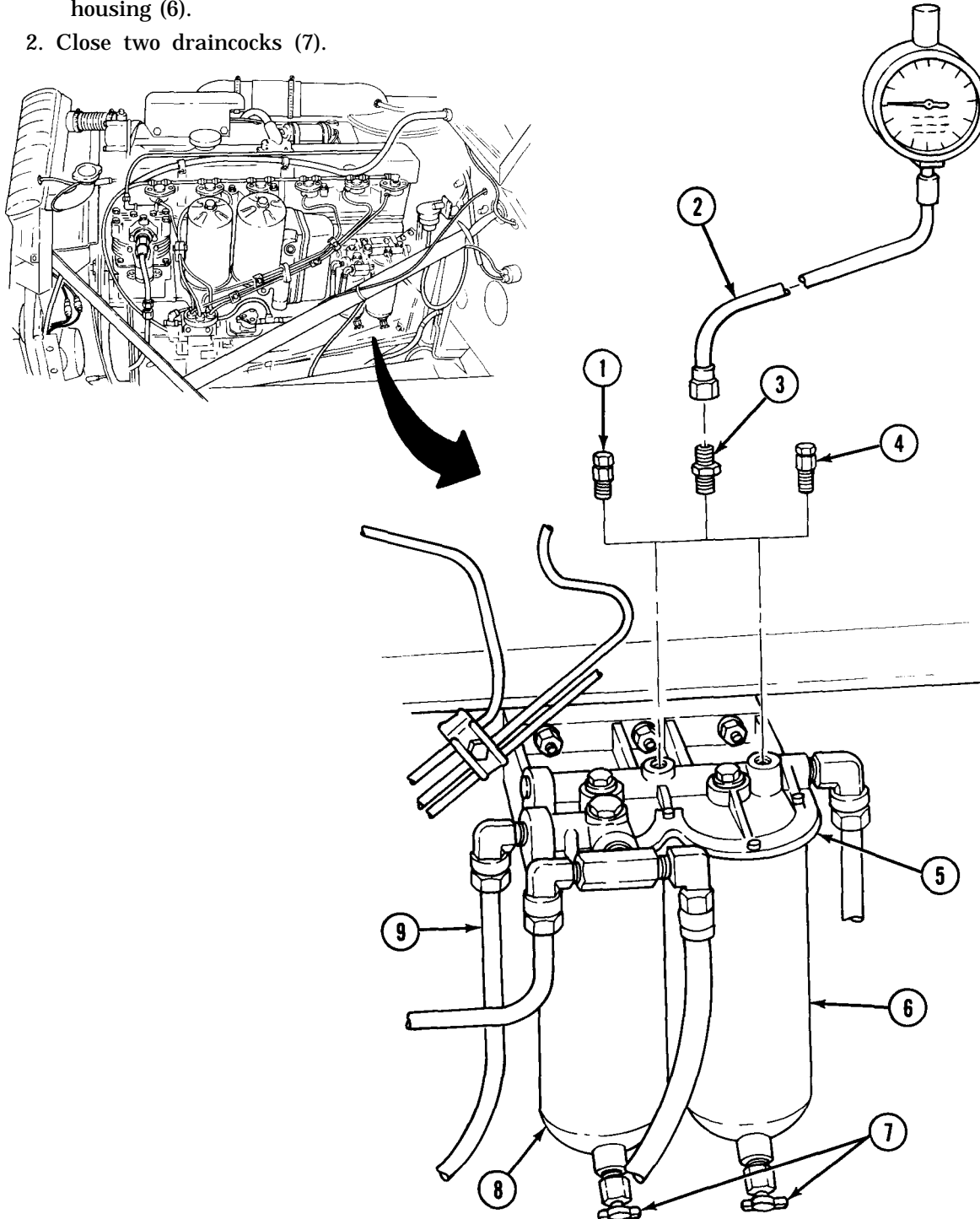

### 3-29. SECONDARY AND FINAL FUEL FILTERS TESTING AND MAINTENANCE (Contd)

#### c. Fuel Filter Head, Secondary, and Final Fuel Filters Removal

**NOTE**

Tag fuel lines for installation.

1. Disconnect three fuel lines (4) and fuel line (7) from three elbows (3) and elbow (8).
2. Remove three elbows (3), elbow (8), and tee (9) from fuel filter head (2).
3. Remove three nuts (6), lockwashers (5), and fuel filter head (2) from engine (1). Discard lockwashers (5).

#### d. Fuel Filters Removal

**NOTE**

Some fuel filters have two bleeder valves.

1. Remove bleeder valve (11) from fuel filter head (2).

**NOTE**

Secondary and final fuel filters are replaced the same way.

2. Remove sleeve nut (10), washer (23), and gasket (22) from fuel filter head (2). Discard gasket (22).
3. Remove secondary fuel filter housing (18) and gasket (21) from filter head (2). Discard gasket (21).
4. Remove filter element (20) from secondary fuel filter housing (18). Discard filter element (20).
5. Remove cotter pin (17) from center post (12). Discard cotter pin (17).
6. Remove cup (13), gasket (14), washer (15), and spring (16) from center post (12). Discard gasket (14).
7. Remove draincock (19) from secondary fuel filter housing (18).

#### e. Cleaning and Inspection

**WARNING**

Drycleaning solvent is flammable and will not be used near open flame. Use only in well-ventilated places. Failure to do so may result in injury to personnel.

1. Clean all components with drycleaning solvent and dry with clean rag.
2. Inspect elbows (3) and (8), tee (9), and center post (12) for burrs and stripped threads.
3. Inspect filter head (2) and filter housing (18) for burrs and scratches on mating surfaces.

#### f. Fuel Filters Installation

1. Install draincock (19) on secondary fuel filter housing (18).
2. Install spring (16), new washer (15), new gasket (14), and cup (13) on center post (12).
3. Install new cotter pin (17) in center post (12).
4. Install new filter element (20) on secondary fuel filter housing (18).
5. Install secondary fuel filter housing (18) and new gasket (21) on fuel filter head (2) with new gasket (22), new washer (23), and sleeve nut (10). Tighten sleeve nut (10) 15 lb-ft (20.3 N·m).

**3-29. SECONDARY AND FINAL FUEL FILTERS TESTING AND MAINTENANCE (Contd)**

NOTE

Some fuel filters have two bleeder valves.

6. Install bleeder valve (11) on fuel filter head (2).

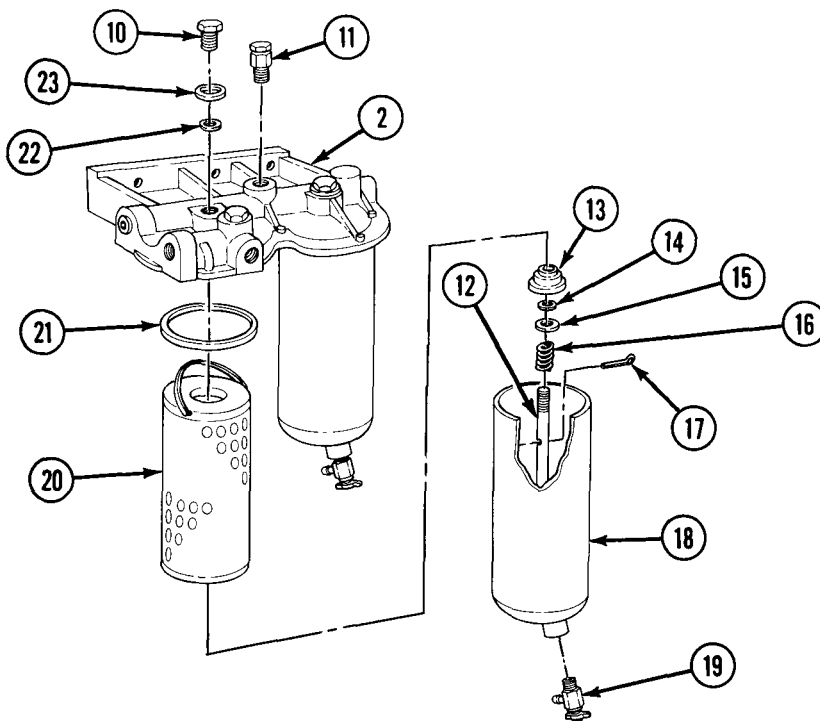
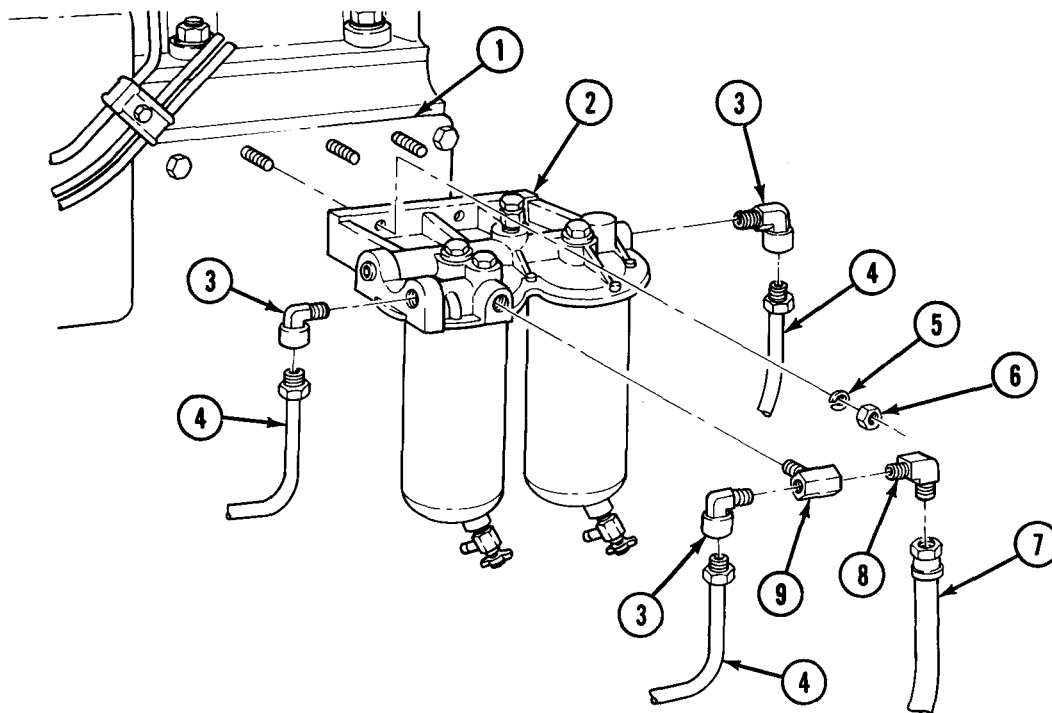



### 3-29. SECONDARY AND FINAL FUEL FILTERS TESTING AND MAINTENANCE (Contd)

#### g. Fuel Filter Head, Secondary, and Final Fuel Filters Installation

1. Install fuel filter head (2) on engine (1) with three new lockwashers (5) and nuts (6).
2. Install tee (9), three elbows (3), and elbow (8) on fuel filter head (2).
3. Connect three fuel lines (4) and fuel line (7) to elbows (3) and (8).

#### h. Bleeding Air

1. Place accessory switch on instrument panel to ON position (TM 9-2320-361-10) to operate in-tank fuel pump. Do not start engine at this time.

#### NOTE

Have drainage container ready to catch fuel.

2. Loosen bleeder valve (11). When fuel starts to flow close bleeder valve (11).

#### NOTE

Perform step 3 for secondary and final fuel filters with two bleeder valves.

3. Open and close each bleeder valve (11) until fuel is clear of air bubbles.

#### WARNING

- Fuel pressure is sufficient to penetrate skin. Wear hand protection at all times when removing injector tubes. Failure to do so may result in injury to personnel.
- Stay clear of moving parts. Failure to do so may result in injury or death to personnel.

4. Loosen injector tube (13) from injector (12). Crank engine (TM 9-2320-361-10) until no air bubbles are observed in fuel. Tighten injector tube (13).
5. Repeat step 4 for remaining injectors (13) in sequence shown.
6. Start engine (TM 9-2320-361-10).
7. With engine running, again open and close bleeder valve (11) until fuel is clear of air bubbles. Tighten bleeder valve (11) and stop engine (TM 9-2320-361-10).
8. Wipe fuel from secondary and final fuel filter housings (10) and injectors (13) with clean rag.

3-29. SECONDARY AND FINAL FUEL FILTERS TESTING AND MAINTENANCE (Contd)

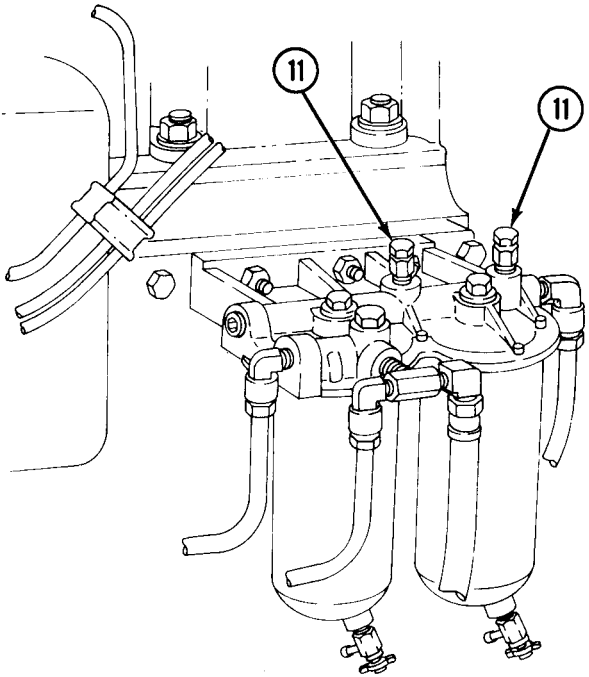
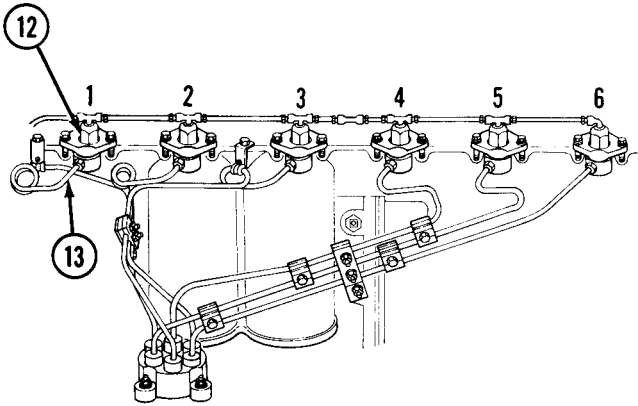
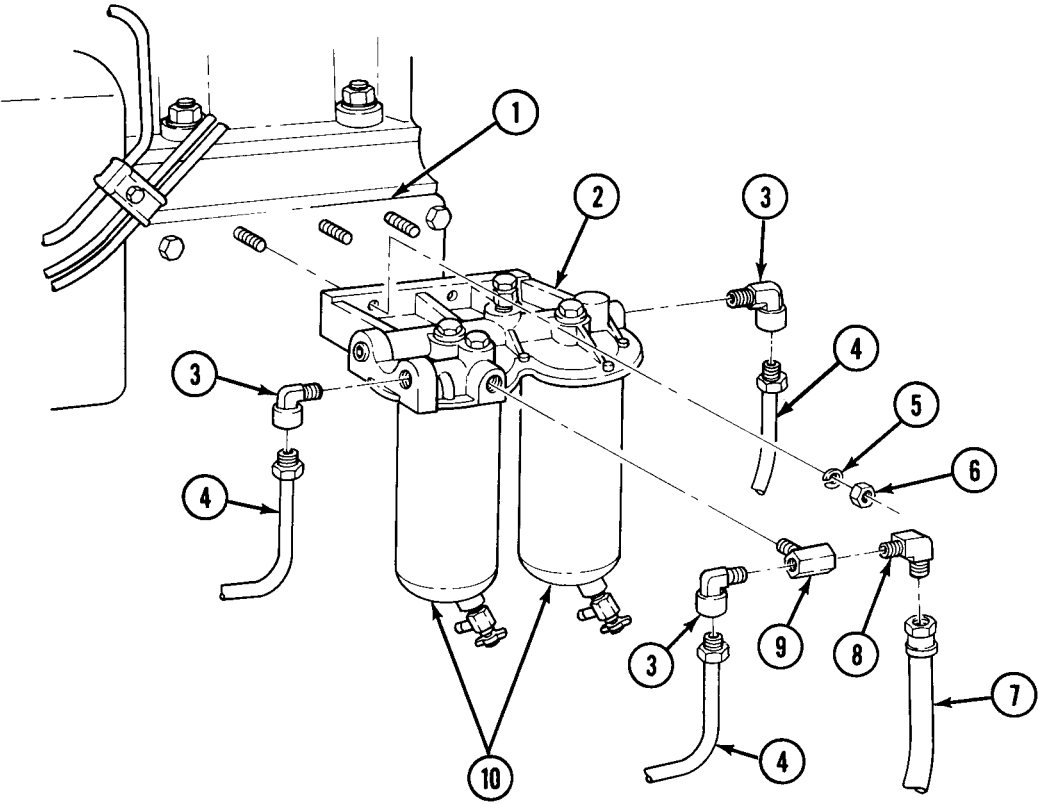

### 3-30. MANIFOLD HEATER (COVERED) REPLACEMENT

This task covers:

- |  |  |
|--|--|
| <ul style="list-style-type: none"> <li>a. Cover Removal</li> <li>b. Ignition Unit Removal</li> <li>c. Fuel Nozzle Removal</li> <li>d. Fuel Pump Removal</li> <li>e. Elbow Removal</li> <li>f. Fuel Filter Removal</li> </ul> | <ul style="list-style-type: none"> <li>g. Fuel Filter Installation</li> <li>h. Elbow Installation</li> <li>i. Fuel Pump Installation</li> <li>j. Fuel Nozzle Installation</li> <li>k. Ignition Unit Installation</li> <li>l. Cover Installation</li> </ul> |
|--|--|

**INITIAL SETUP:**

APPLICABLE MODELS

All

MATERIALS/PARTS

Two manifold heater fuel filters  
 Eight lockwashers  
 Two gaskets  
 Two filters

REFERENCES (TM)

TM 9-2320-361-10  
 TM 9-2320-361-20P

EQUIPMENT CONDITION

- Parking brake set (TM 9-2320-361-10).
- Hood raised and secured (TM 9-2320-361-10).
- Battery ground cable disconnected (para. 4-48).
- Breather tube removed (para. 3-6).

#### a. Cover Removal

Remove four screws (1), clamp (5), and fuel pump cover (2) from bracket (11).

#### b. Ignition Unit Removal

1. Remove screw (10), lockwasher (9), and wiring harness ground wire (8) from bracket (11). Discard lockwasher (9).
2. Disconnect wire (7) from wiring harness (6).
3. Disconnect wiring harness (6) from ignition unit (4) and fuel pump (12).
4. Disconnect cable assembly (23) from ignition unit (4) and spark plug (15).
5. Remove two clamp assemblies (3) and ignition unit (4) from bracket (11).

#### c. Fuel Nozzle Removal

1. Remove spark plug (15) and gasket (14) from elbow (13). Discard gasket (14).
2. Disconnect fuel return tube (21) and fuel inlet tube (22) from adapters (20) and (16).
3. Remove adapters (20) and (16) from fuel nozzle (19).
4. Loosen nut (18) and remove fuel nozzle (19) and nut (18) from elbow (13).
5. Remove two filters (17) from fuel nozzle (19). Discard filters (17).

3-30. MANIFOLD HEATER (COVERED) REPLACEMENT (Contd)

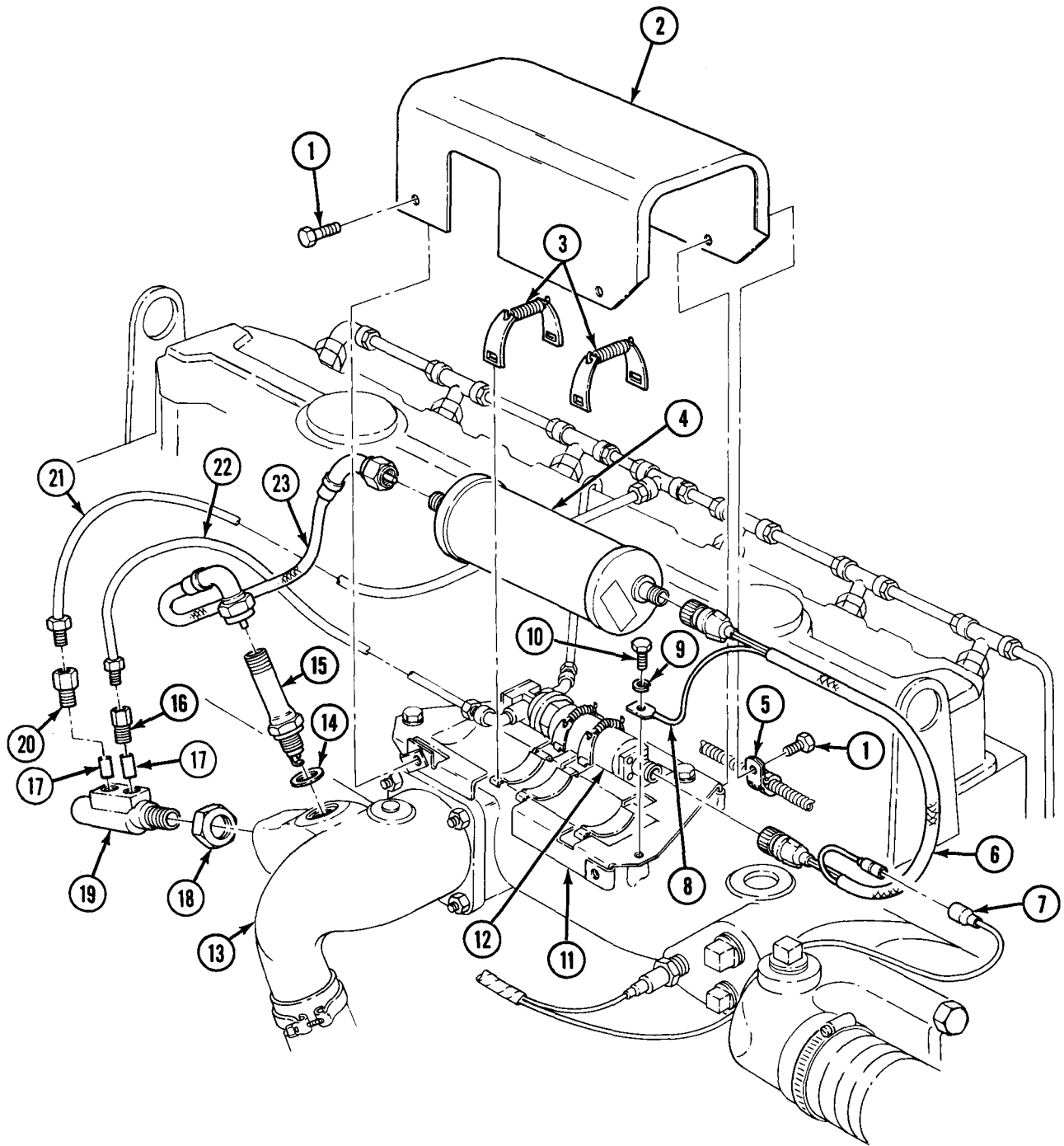

### 3-30. MANIFOLD HEATER (COVERED) REPLACEMENT (Contd)

#### d. Fuel Pump Removal

1. Remove fuel inlet tube (20) from elbow (1).
2. Remove fuel supply tube (5) from elbow (4).
3. Remove two clamps (3) and fuel pump (2) from bracket (10).
4. Remove elbows (1) and (4) from fuel pump (2).
5. Remove two screws (19), lockwashers (18), bracket (10), and four nuts (9) from air intake manifold (8). Discard lockwashers (18).
6. Remove fuel return tube (7) from tee (6).

#### e. Elbow Removal

1. Loosen clamp (11) on air intake tube (12).
2. Remove four nuts (15), lockwashers (16), clamp (14), elbow (13), and gasket (17) from air intake manifold (8) and air intake tube (12). Discard lockwashers (16) and gasket (17).

#### f. Fuel Filter Removal

1. Disconnect fuel supply tube (5) from adapter (21).
2. Disconnect fuel supply tube (28) from fuel filter (29).
3. Remove screw (27), lockwasher (26), clamp (25), fuel filter (29), and clamp (24) from side of engine (23). Discard lockwasher (26) and fuel filter (29).
4. Remove adapter (21) and elbow (22) from fuel filter (29).

#### g. Fuel Filter Installation

1. Install elbow (22) and adapter (21) on new fuel filter (29).
2. Install fuel filter (29) on engine (23) with clamps (24) and (25), new lockwasher (26) and screw (27).
3. Connect fuel supply tube (28) to fuel filter (29).
4. Connect fuel supply tube (5) to adapter (21).

#### h. Elbow Installation

1. Install new gasket (17), elbow (13), and clamp (14) on air intake tube (12) and air intake manifold (8) with four new lockwashers (16) and nuts (15).
2. Tighten clamp (11) on air intake tube (12).

#### i. Fuel Pump Installation

1. Install fuel return tube (7) to tee (6).
2. Install four nuts (9) on bracket (10) and install bracket (10) on air intake manifold (8) with two screws (19) and new lockwashers (18).
3. Install elbows (1) and (4) to fuel pump (2).
4. Install fuel pump (2) to bracket (10) with two clamps (3).
5. Connect fuel supply tube (5) to elbow (4).
6. Connect fuel inlet tube (20) to elbow (1).

**3-30. MANIFOLD HEATER (COVERED) REPLACEMENT (Contd)**

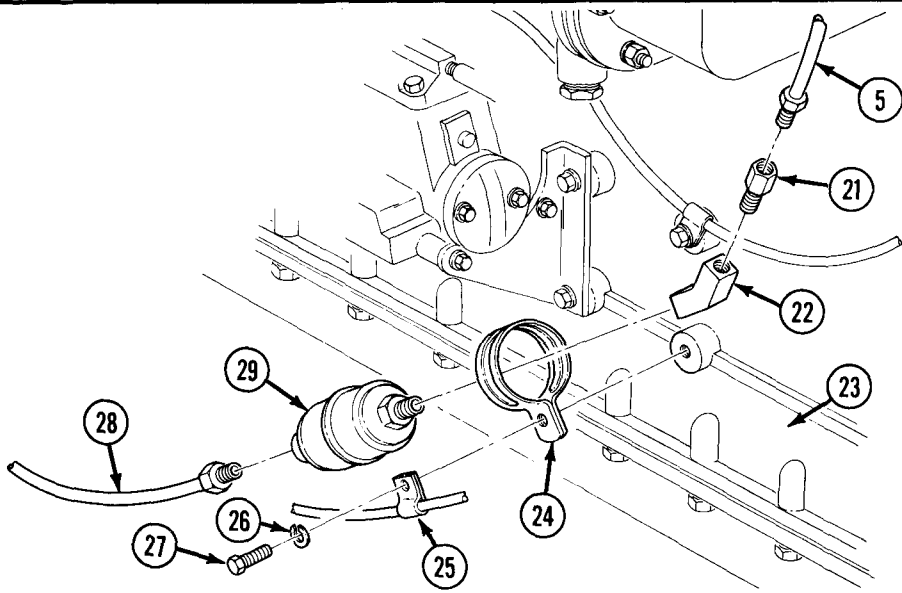
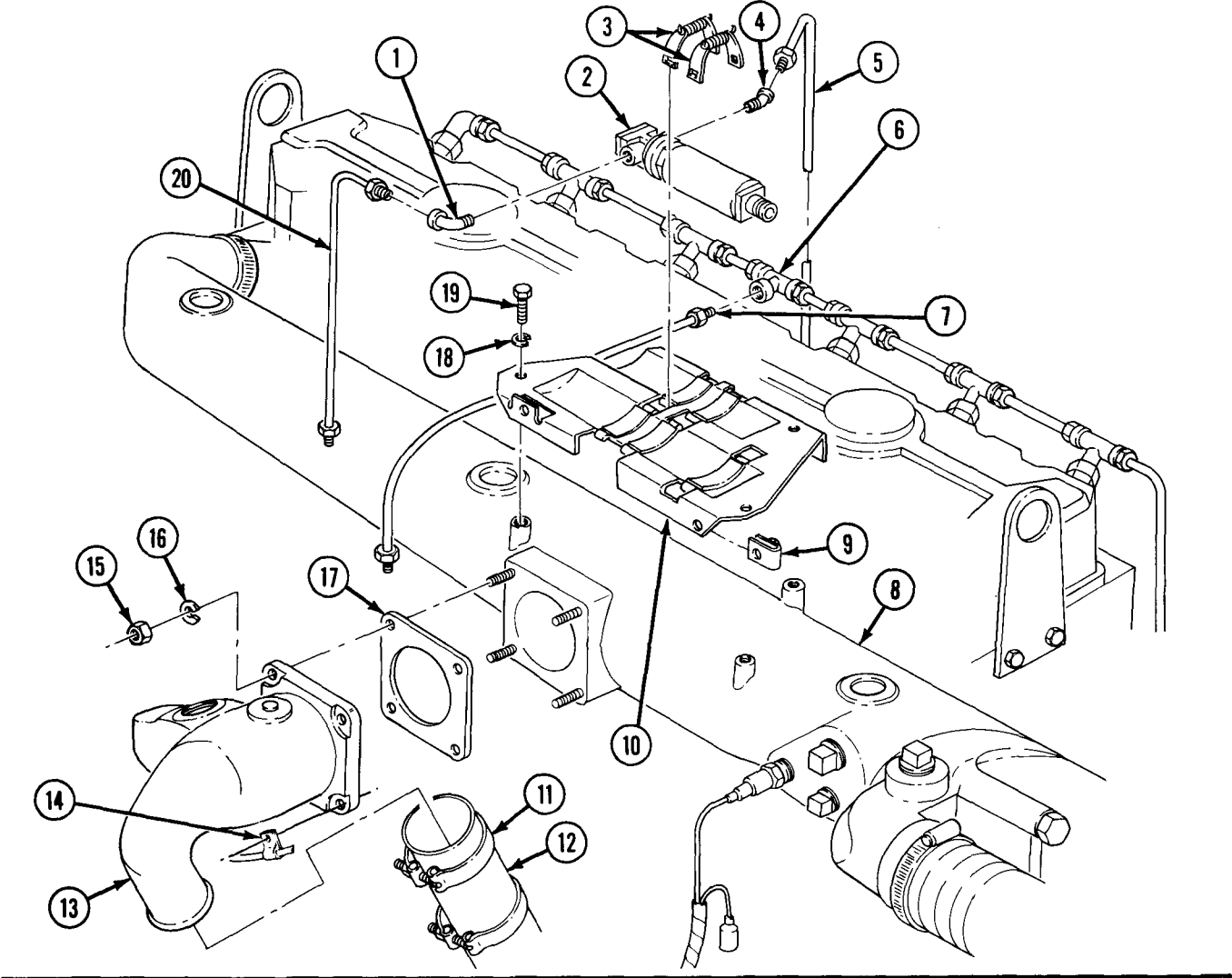

### 3-30. MANIFOLD HEATER (COVERED) REPLACEMENT (Contd)

#### j. Fuel Nozzle Installation

1. Install two new filters (17) on fuel nozzle (19).
2. Install fuel nozzle (19) on elbow (13) with nut (18). Tighten nut (18) securely.
3. Install adapters (16) and (20) on fuel nozzle (19).
4. Connect fuel inlet tube (22) and fuel return tube (21) to adapters (16) and (20).
5. Install new gasket (14) and spark plug (15) on elbow (13).

#### k. Ignition Unit Installation

1. Install ignition unit (4) on bracket (11) with two clamp assemblies (3).
2. Connect cable assembly (23) to ignition unit (4) and spark plug (15).
3. Connect wiring harness (6) to fuel pump (12) and ignition unit (4).
4. Connect wiring harness ground wire (8) to bracket (11) with screw (10) and new lockwasher (9).
5. Connect wiring harness (6) to wire (7).

#### l. Cover Installation

Install fuel pump cover (2) and clamp (5) on bracket (11) with four screws (1).

**3-30. MANIFOLD HEATER (COVERED) REPLACEMENT (Contd)**

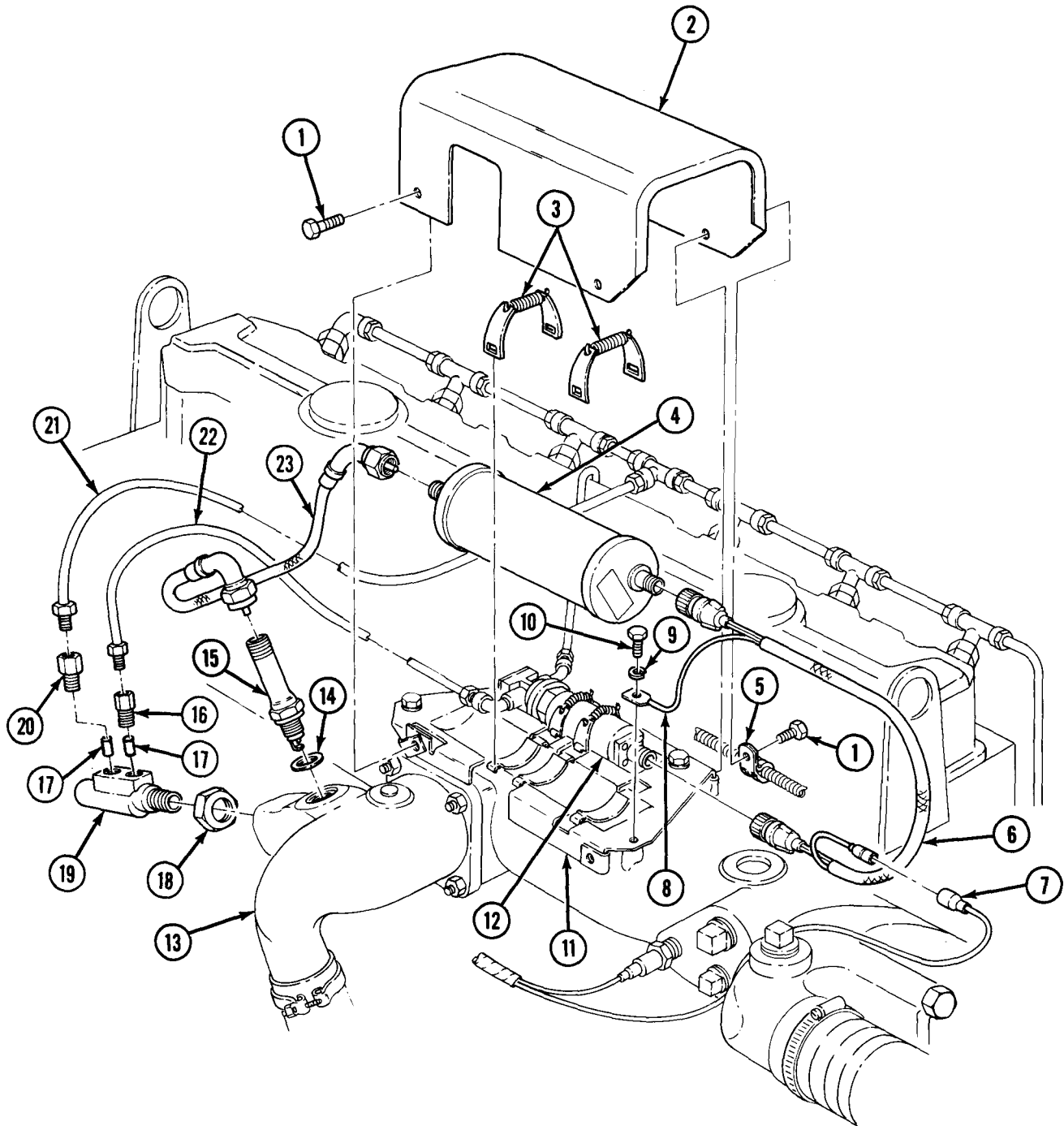

**FOLLOW-ON TASKS:**

- Install breather tube (para. 3-6).
- Connect battery ground cable (para. 4-48).



### 3-31. MANIFOLD HEATER (UNCOVERED) REPLACEMENT

This task covers:

- |  |   |
|--|---|
| <ul style="list-style-type: none"> <li>a. Fuel Nozzle Removal</li> <li>b. Ignition Unit Removal</li> <li>c. Fuel Filter Removal</li> <li>d. Fuel Pump Removal</li> <li>e. Elbow Removal</li> </ul> | <ul style="list-style-type: none"> <li>f. Elbow Installation</li> <li>g. Fuel Pump Installation</li> <li>h. Fuel Filter Installation</li> <li>i. Ignition Unit Installation</li> <li>j. Fuel Nozzle Installation</li> </ul> |
|--|---|

**INITIAL SETUP:**

APPLICABLE MODELS

All

MATERIALS/PARTS

Manifold heater fuel filter  
 Nine lockwashers  
 Two gaskets  
 Two filters

REFERENCES (TM)

TM 9-2320-361-10  
 TM 9-2320-361-20P

EQUIPMENT CONDITION

- Parking brake set (TM 9-2320-361-10).
- Hood raised and secured (TM 9-2320-361-10).
- Battery ground cable disconnected (para. 4-48).

#### a. Fuel Nozzle Removal

1. Disconnect cable assembly (38) from spark plug (32).
2. Remove spark plug (32) and gasket (31) from elbow (25). Discard gasket (31).
3. Disconnect fuel return tube (7) and fuel inlet tube (10) from adapters (30) and (28).
4. Loosen nut (26) and remove fuel nozzle (27) and nut (26) from elbow (25).
5. Remove two filters (29) from fuel nozzle (27). Discard filters (29).

#### b. Ignition Unit Removal

1. Remove cable assembly (38) from ignition unit (4).
2. Remove screw (1), lockwasher (2), and ground wire (41) from engine (40) and disconnect wiring harness (39) from ignition unit (4). Discard lockwasher (2).
3. Remove two screws (3), lockwashers (5), clamps (36), and ignition unit (4) from engine (40). Discard lockwashers (5).

#### c. Fuel Filter Removal

1. Disconnect wire (11) from wire (12).
2. Remove wiring harness (21) from fuel pump (14).
3. Remove fuel return line (7) from tee (9).
4. Disconnect fuel supply line (35) from fuel filter (18).
5. Remove fuel filter (18), elbow (16), and pipe coupling (15) from fuel pump (14). Discard fuel filter (18).

#### d. Fuel Pump Removal

1. Remove fuel inlet tube (10) and elbow (13) from fuel pump (14).
2. Remove two screws (6), lockwashers (8), clamps (20), and fuel pump (14) from water outlet manifold (19). Discard lockwashers (8).

**3-31. MANIFOLD HEATER (UNCOVERED) REPLACEMENT (Contd)**

**e. Elbow Removal**

1. Loosen clamp (17) on air intake tube (23).
2. Remove four nuts (33), lockwashers (34), clamp (37), elbow (25), and gasket (24) from air intake manifold (22) and air intake tube (23). Discard lockwashers (34) and gasket (24).

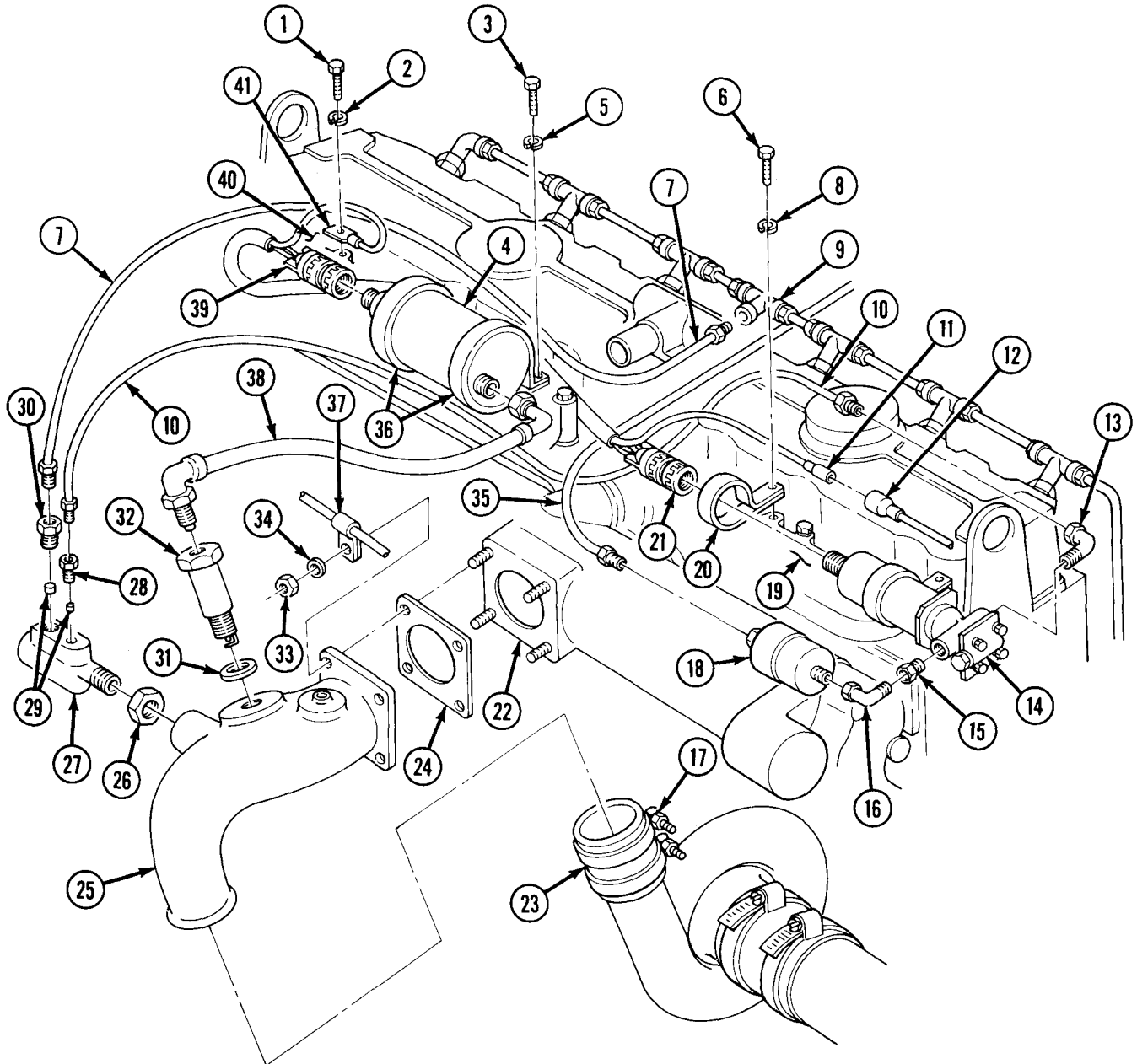

### 3-31. MANIFOLD HEATER (UNCOVERED) REPLACEMENT (Contd)

#### f. Elbow Installation

1. Install new gasket (24), elbow (25), and clamp (37) on air intake tube (23) and air intake manifold (22) with four new lockwashers (34) and nuts (33).
2. Tighten clamp (17) on air intake tube (23).

#### g. Fuel Pump Installation

1. Install fuel pump (14) on water outlet manifold (19) with two clamps (20), new lockwashers (8), and screws (6).
2. Install elbow (13) on fuel pump (14) and connect fuel inlet tube (10) to elbow (13).

#### h. Fuel Filter Installation

1. Install pipe coupling (15), elbow (16), and new fuel filter (18) on fuel pump (14).
2. Connect fuel supply line (35) to fuel filter (18).
3. Connect fuel return line (7) to tee (9).
4. Connect wiring harness (21) to fuel pump (14).
5. Connect wire (11) to wire (12).

#### i. Ignition Unit Installation

1. Install ignition unit (4) on engine (40) with two clamps (36), new lockwashers (5), and screws (3).
2. Connect cable assembly (38) to ignition unit (4).
3. Connect wiring harness (39) to ignition unit (4).
4. Install ground wire (41) on engine (40) with new lockwasher (2) and screw (1).

#### j. Fuel Nozzle Installation

1. Install two new filters (29) on fuel nozzle (27).
2. Install fuel nozzle (27) and nut (26) on elbow (25).
3. Install adapters (28) and (30) on fuel nozzle (27).
4. Connect fuel inlet tube (10) and fuel return tube (7) to adapters (28) and (30).
5. Install new gasket (31) and spark plug (32) on elbow (25).
6. Connect cable assembly (38) to spark plug (32).

**3-31. MANIFOLD HEATER (UNCOVERED) REPLACEMENT (Contd)**

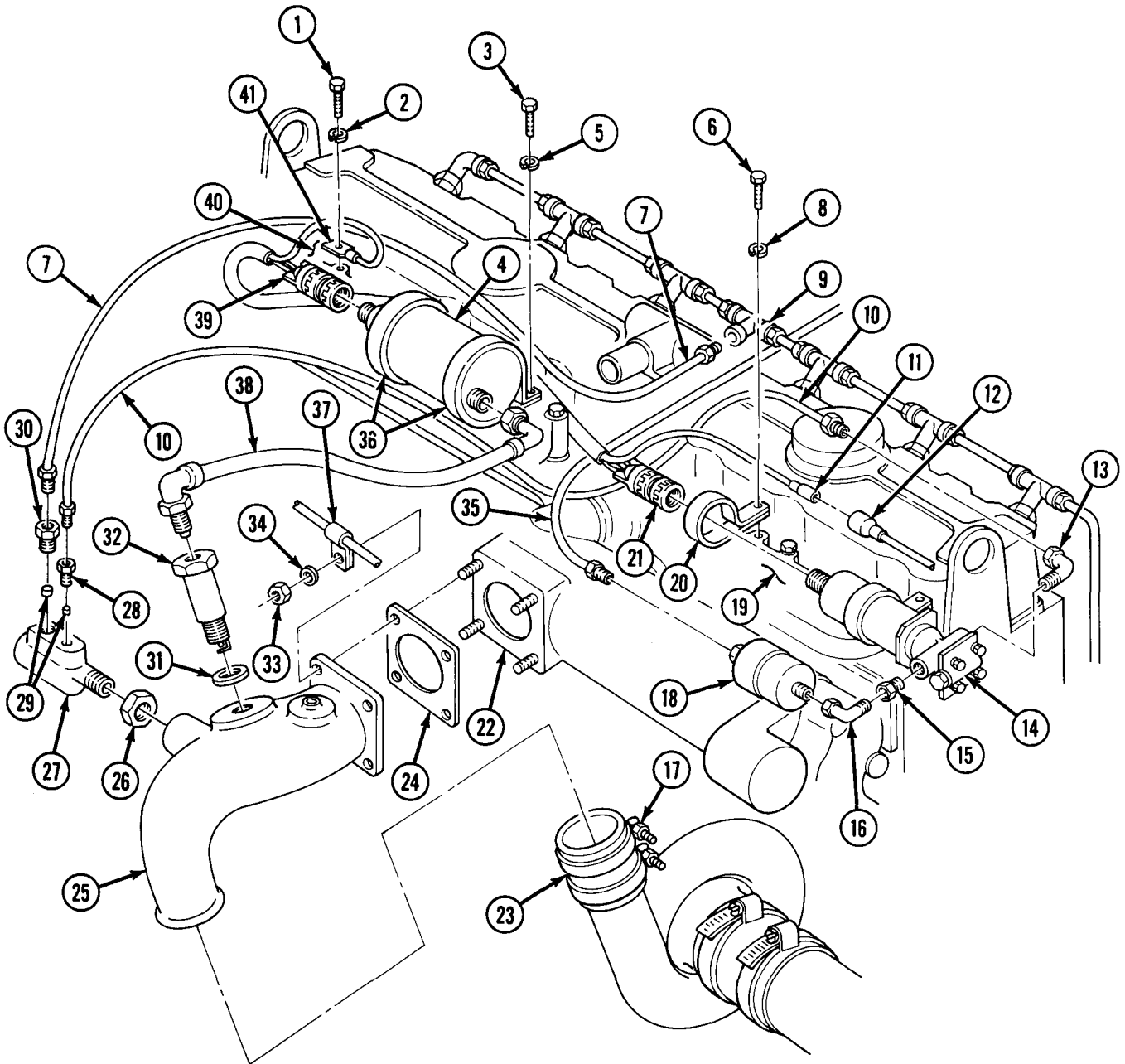

FOLLOW-ON TASK: Connect battery ground cable (para.4-48).

Section VII. ACCELERATOR SYSTEM MAINTENANCE

**3-32. ACCELERATOR SYSTEM MAINTENANCE INDEX**

PARA. NO.	TITLE	PAGE NO.
3-33.	Accelerator Pedal, Brackets, and Rod Maintenance	3-70
3-34.	Engine Stop Control Cable Maintenance	3-76
3-35.	Hand Throttle Control Cable Maintenance	3-78

**3-33. ACCELERATOR PEDAL, BRACKETS, AND ROD MAINTENANCE**

This task covers:

- a. Removal
- b. Installation

c. Adjustment

**INITIAL SETUP:**

APPLICABLE MODELS

All

MATERIALS/PARTS

Five locknuts  
Seven cotter pins

PERSONNEL REQUIRED

Two

REFERENCES (TM)

TM 9-2320-361-10  
TM 9-2320-361-20P

EQUIPMENT CONDITION

- Parking brake set (TM 9-2320-361-10).
- Hood raised and secured (TM 9-2320-361-10).

**a. Removal**

1. Remove throttle return spring (10) from swivel (9) and throttle return clip (1).
2. Remove screw (3), washers (2), and throttle return clip (1) from steering gear housing (12).
3. Remove cotter pin (4) and pin (11) from swivel (9) and disconnect swivel (9) from pump lever (13). Discard cotter pin (4).
4. Loosen screw (5) and remove connector (6), screw (5), and control wire (7) from accelerator rod (8).
5. Remove locknut (19), ball joint (21), and accelerator rod (22) from lever (20). Discard locknut (19).
6. Remove cotter pin (18), washer (17), and connecting link (16) from lever (20). Discard cotter pin (18).
7. Remove two cotter pins (14), pin (15), and lever (20) from bracket (24). Discard cotter pins (14).

**NOTE**

Assistant will help with step 8.

8. Remove two locknut (25), screws (26), and bracket (24) from cab floor (23). Discard locknuts (25).

**3-33. ACCELERATOR PEDAL, BRACKETS, AND ROD MAINTENANCE (Contd)**

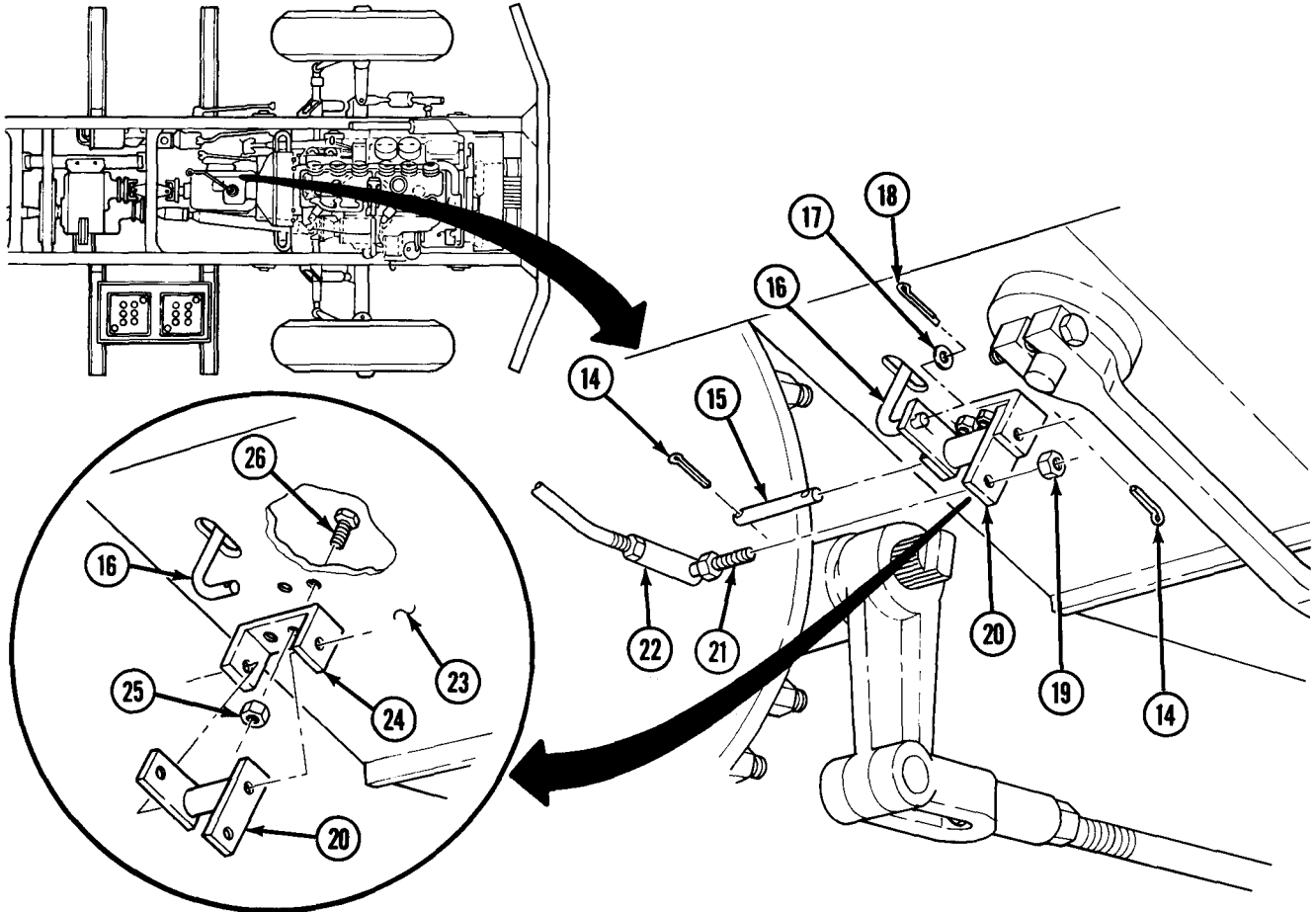
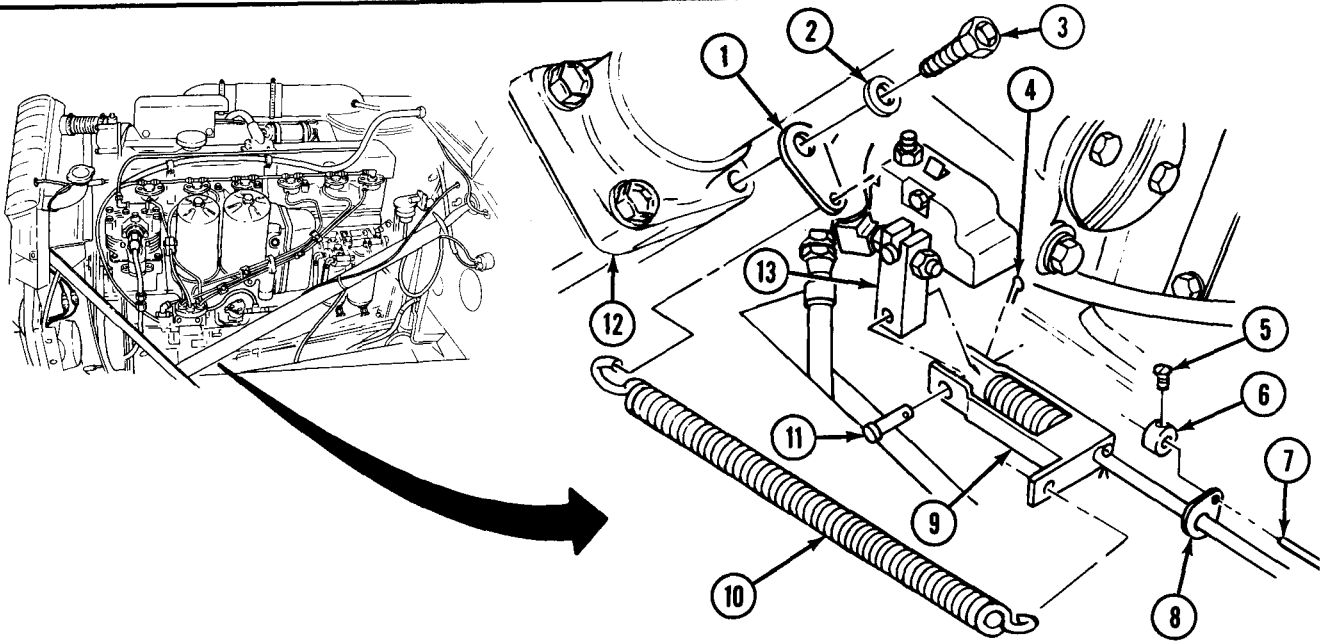

**3-33. ACCELERATOR PEDAL, BRACKETS, AND ROD MAINTENANCE (Contd)**

9. Remove cotter pin (3) and connecting link (2) from accelerator pedal (4). Discard cotter pin (3).
10. Remove pin (8) and accelerator pedal (4) from bracket (7).

**NOTE**

Assistant will help with step 11.

11. Remove two locknuts (6), screws (1), and bracket (7) from cab floor (5). Discard locknuts (6).
12. Remove two cotter pins (12), washer (9), spring (10), and swivel (11) from accelerator rod (13). Discard cotter pins (12).
13. Loosen nut (14) and remove ball point (15) and nut (14) from accelerator rod (13).

**b. Installation**

1. Install nut (14) and ball joint (15) on accelerator rod (13). Tighten nut (14).
2. Install swivel (11), spring (10), and washer (9), on accelerator rod (13) with two new cotter pins (12).

**NOTE**

Assistant will help with step 3.

3. Install bracket (7) on cab floor (5) with two screws (1) and new locknuts (6).
4. Install accelerator pedal (4) on bracket (7) with pin (8).
5. Install connecting link (2) on accelerator pedal (4) with new cotter pin (3).

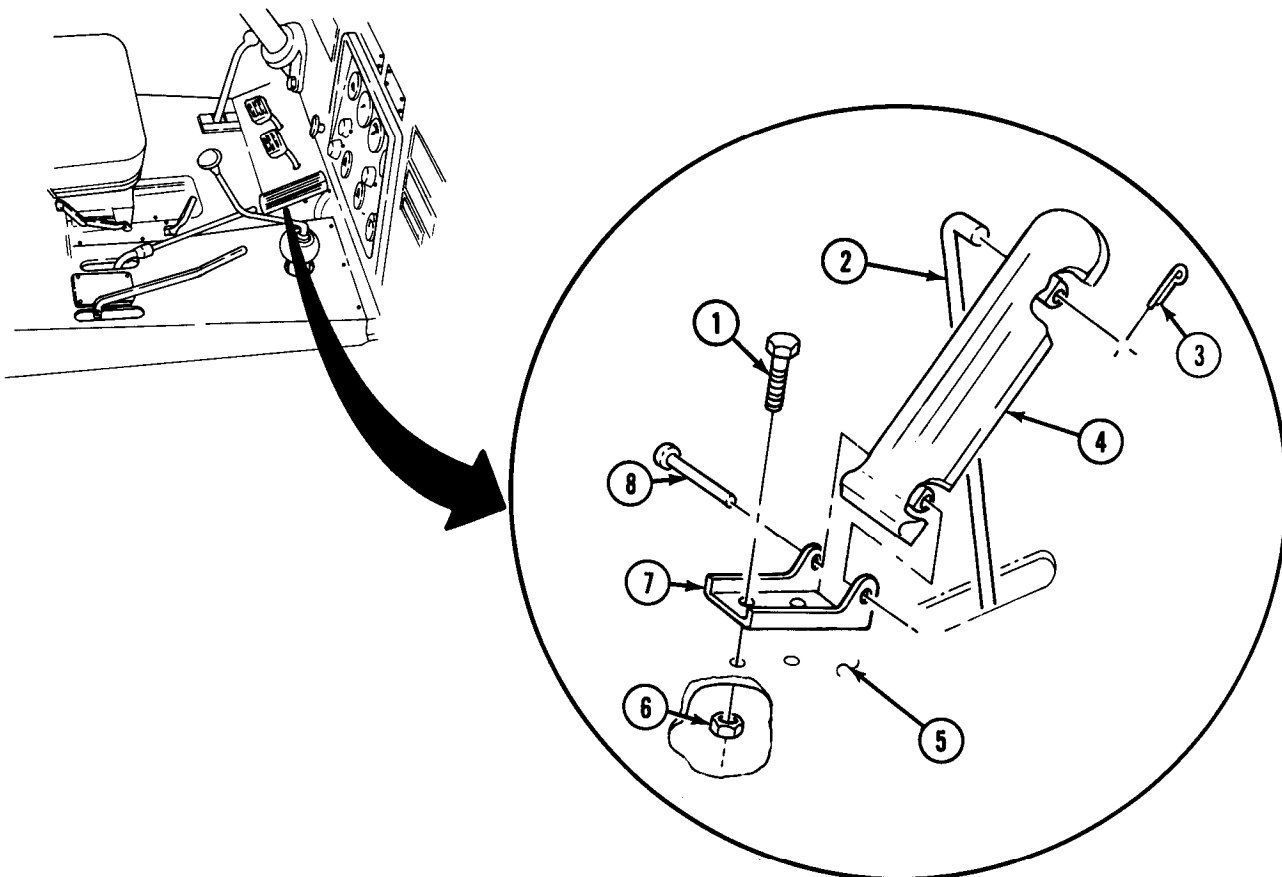

**3-33. ACCELERATOR PEDAL, BRACKETS, AND ROD MAINTENANCE (Contd)**

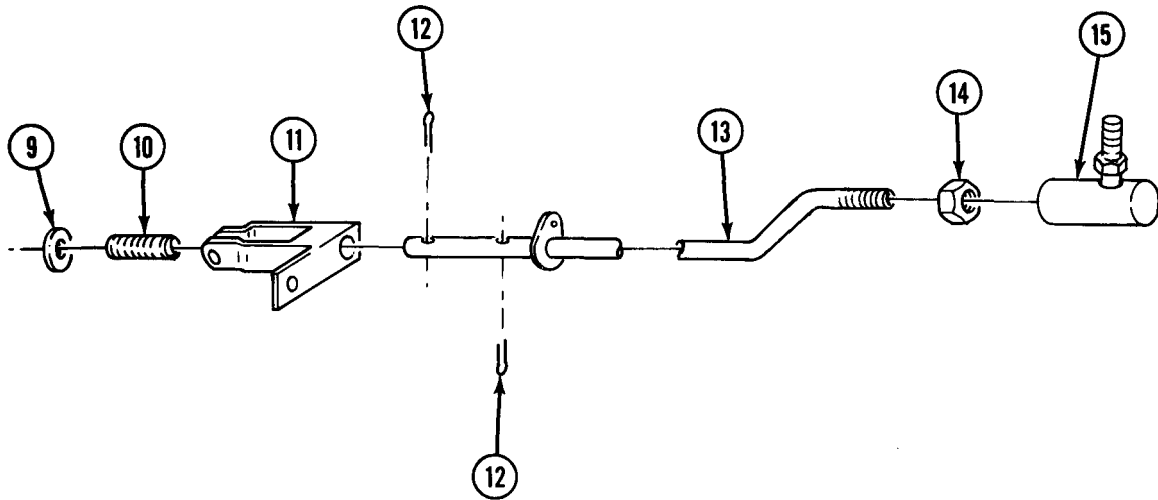

**NOTE**

Assistant will help with step 6.

6. Install bracket (17) on cab floor (5) with two screws (16) and new locknuts (19).
7. Install lever (18) on bracket (17) with pin (21) and two new cotter pins (20).
8. Install connecting link (2) on lever (18) with washer (23) and new cotter pin (22).
9. Install ball joint (15) and accelerator rod (13) on lever (18) with new locknut (24).

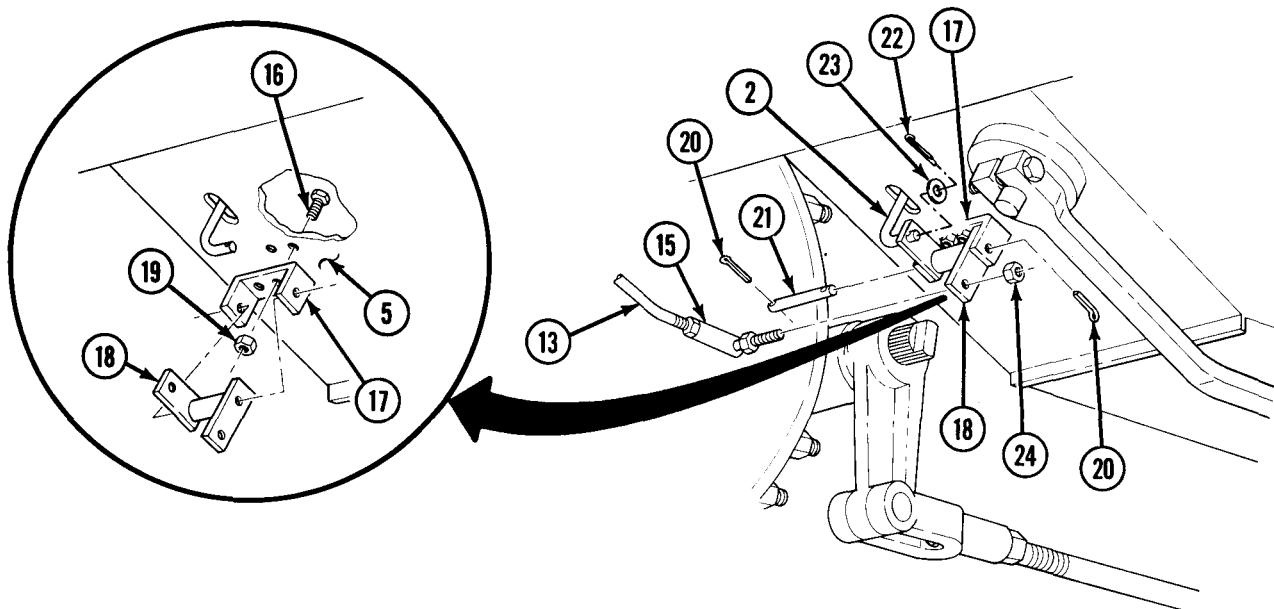



**3-33. ACCELERATOR PEDAL, BRACKETS, AND ROD MAINTENANCE (Contd)**

10. Connect swivel (9) to pump lever (12) with pin (11) and new cotter pin (4).
11. Position control wire (7) through flange on accelerator rod (8) and install connector (6) and screw (5) on control wire (7). Do not tighten. Position connector (6) 0.125 in. (0.32 mm) from flange on accelerator rod (8) and tighten screw (5).
12. Install throttle return clip (1) on steering gear housing (13) with washer (2) and screw (3).
13. Install spring (10) on throttle return clip (1) and swivel (9).

**c. Adjustment**

1. Remove locknut (15) from threaded stud (16) and disconnect threaded stud (16) of ball joint (18) from lever (17).
2. Loosen nut (19) on accelerator rod (14).

**NOTE**

Rod is shortened by turning ball joint clockwise on rod and lengthened by turning ball joint counterclockwise on rod.

3. Shorten or lengthen accelerator rod (14) until threaded stud (16) of ball joint (18) will freely slide into hole of lever (17).
4. Install locknut (15) on threaded stud (16).
5. Tighten nut (19) on rod (14).

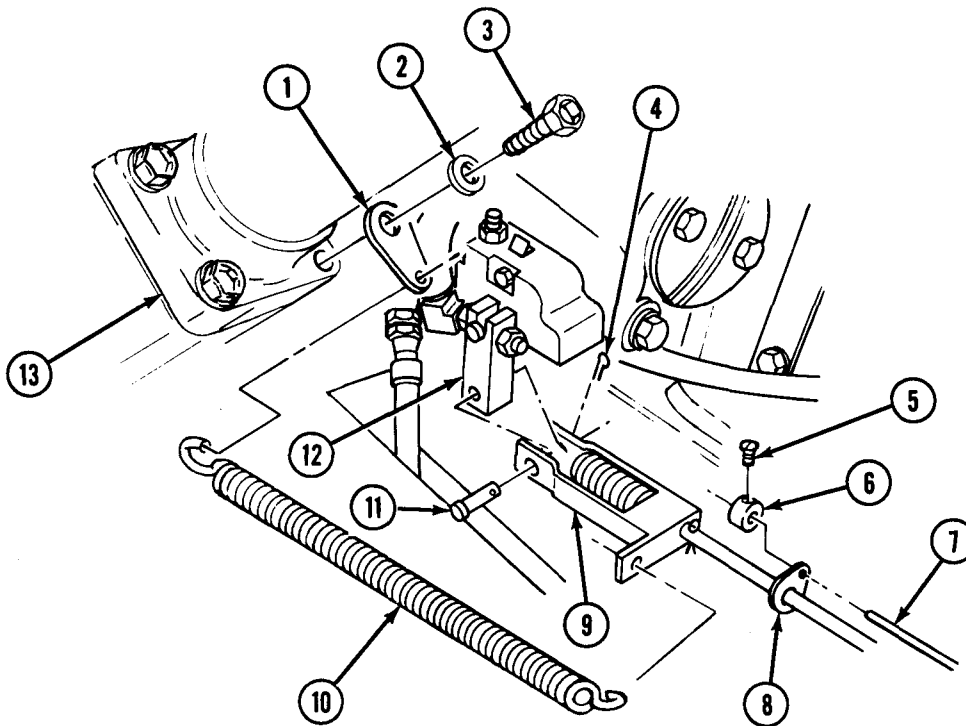

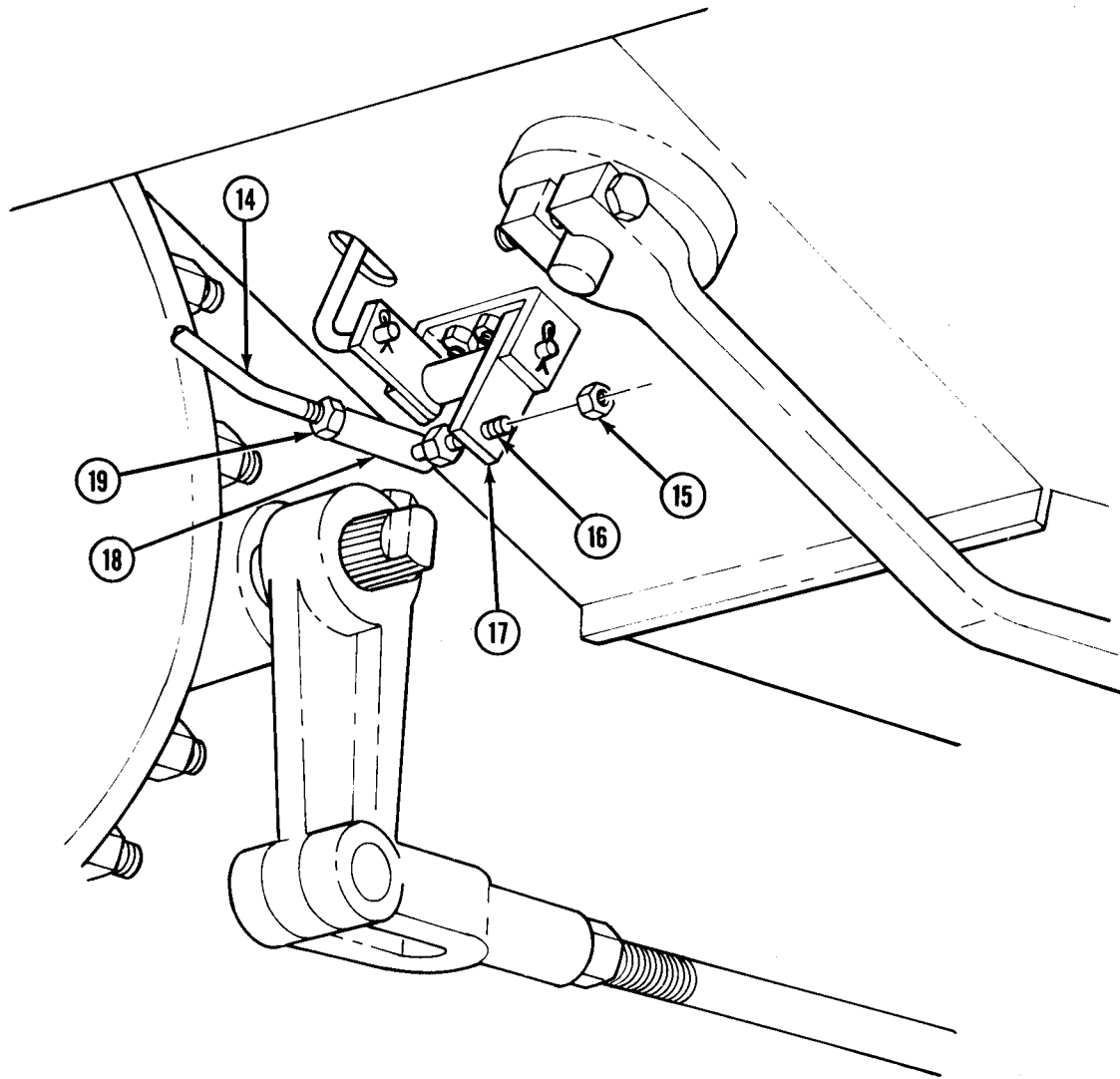
**3-33. ACCELERATOR PEDAL, BRACKETS, AND ROD MAINTENANCE (Contd)**

FOLLOW-ON TASK: Start engine (TM 9-2320-361-10) and check throttle for proper operation.

### 3-34. ENGINE STOP CONTROL CABLE MAINTENANCE

This task covers:

- a. Removal
- b. Installation

- c. Adjustment

**INITIAL SETUP:**

APPLICABLE MODELS

All

MATERIALS/PARTS

Four lockwashers  
 Cotter pin  
 Tiedown strap (Appendix C, Item 20)

REFERENCES (TM)

TM 9-2320-361-10  
 TM 9-2320-361-20P

EQUIPMENT CONDITION

- Parking brake set (TM 9-2320-361-10).
- Hood raised and secured (TM 9-2320-361-10).

#### a. Removal

1. Remove tiedown strap (8) and engine stop control cable (1) from around steering column (9).
2. Remove nut (19), two lockwashers (12), and screw (13) from clamp (16). Discard lockwashers (12).
3. Straighten end of control cable wire (11) and loosen screw (10) on swivel (21).
4. Remove control cable wire (11) and control cable (1) from swivel (21) and clamp (16).
5. Remove cotter pin (18), swivel (21) and screw (10) from fuel shutoff valve (20). Discard cotter pin (18).
6. Remove screw (14), lockwasher (15) and clamp (16) from fuel injection pump (17). Discard lockwasher (15).
7. Loosen nut (6) behind instrument panel (5) and slide nut (6) and lockwasher (3) back on control cable (1).
8. Pull engine stop control (4) out from instrument panel (5) and remove nut (6) and lockwasher (3) from cable (1) as end of cable (1) comes through grommet (7) in firewall (2). Discard lockwasher (3).
9. Remove grommet (7) from firewall (2).

#### b. Installation

1. Install grommet (7) on firewall (2).
2. Route end of engine stop control (4) through instrument panel (5).
3. Position new lockwasher (3) and nut (6) on end of control cable (1) and insert control cable (1) through grommet (7) and firewall (2).
4. Install engine stop control (4) on instrument panel (5) with lockwasher (3) and nut (6).
5. Install clamp (16) on fuel injection pump (17) with new lockwasher (15) and screw (14).
6. Install swivel (21) on fuel shutoff valve (20) with new cotter pin (18) and install screw (10) on swivel (21). Do not tighten.
7. Slide control cable (1) through clamp (16) and control cable wire (11) through swivel (21).
8. Install two new lockwashers (12), screw (13), and nut (19) on clamp (16). Do not tighten nut (19).

#### c. Adjustment

1. Push ENGINE STOP control (4) all the way in.
2. Pull fuel shutoff valve (20) out (toward firewall).

### 3-34. ENGINE STOP CONTROL CABLE MAINTENANCE (Contd)

3. Position control cable (1) in clamp (16) with end at least 1/2 in. (13 mm) away from fuel shutoff valve (20).
4. Tighten nut (19) on screw (13).
5. Push fuel shutoff valve (20) all the way in and tighten screw (10) on control cable wire (11). Bend end of control cable wire (11) up.
6. Install tiedown strap (8) around steering column (9) and control cable (1).

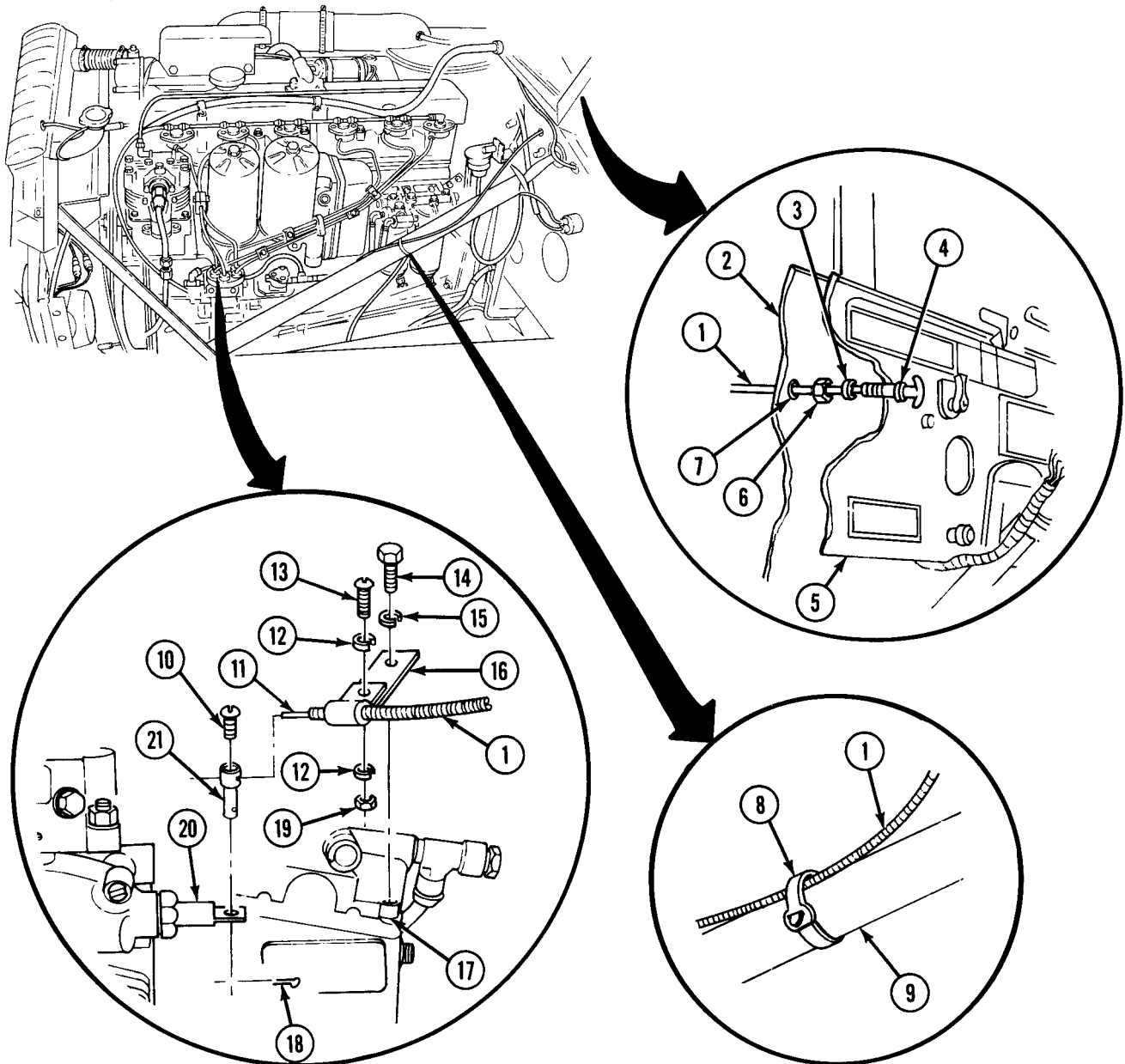

FOLLOW-ON TASK: Start and stop engine (TM 9-2320-361-10).

**3-35. HAND THROTTLE CONTROL CABLE MAINTENANCE**

This task covers:

- a. Removal
- b. Installation

c. Adjustment

**INITIAL SETUP:**

APPLICABLE MODELS

All

MATERIAL/PARTS

Lockwasher

PERSONNEL REQUIRED

Two

REFERENCES (TM)

TM 9-2320-361-10

TM 9-2320-361-20P

EQUIPMENT CONDITION

- Parking brake set (TM 9-2320-361-10).
- Hood raised and secured (TM 9-2320-361-10).

**a. Removal**

1. Straighten end of control wire (4) and remove screw (1), connector (2), and control wire (4) from accelerator rod flange (3).

**NOTE**

Assistant will help with step 2.

2. Remove nut (7) from screw (6) and slide nut (7) off end of control cable (8).
3. Pull control cable (8) up through hole in cab floor (5) and remove screw (6) from end of control cable (8).
4. Remove nut (12) and lockwasher (11) from control cable (8). Discard lockwasher (11).
5. Pull hand throttle control (10) out from instrument panel (9).

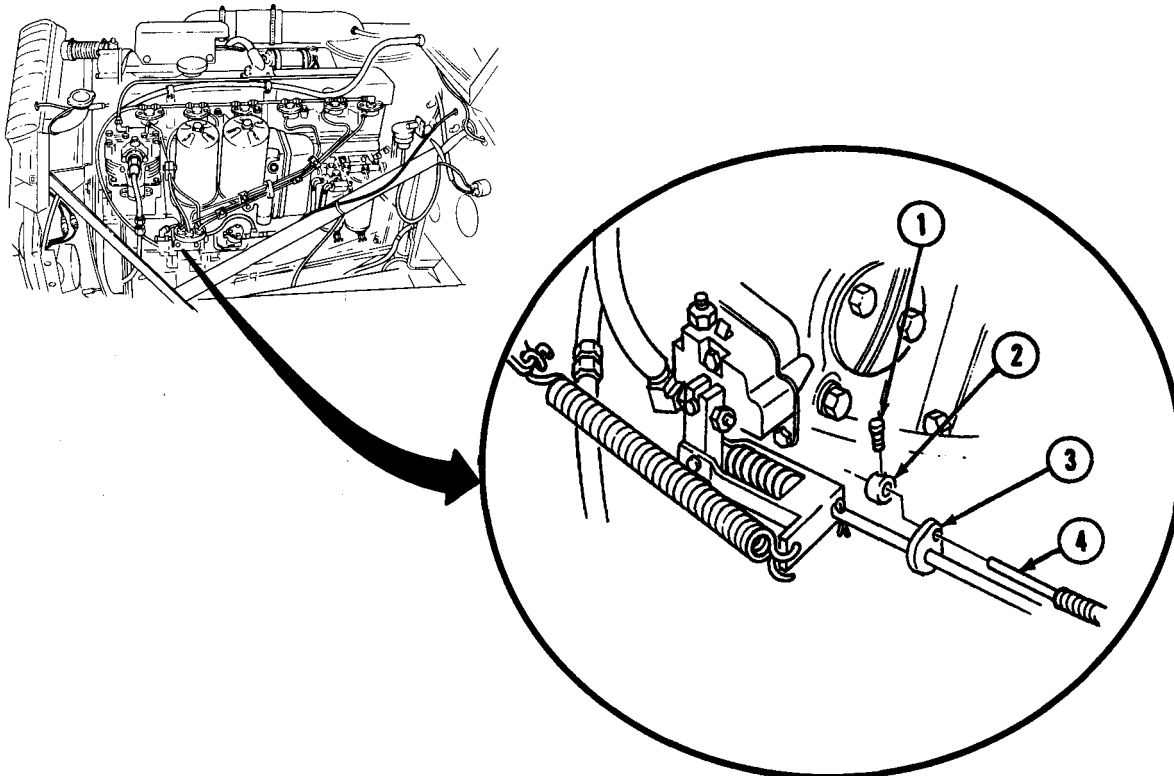

3-35. HAND THROTTLE CONTROL CABLE MAINTENANCE (Contd)

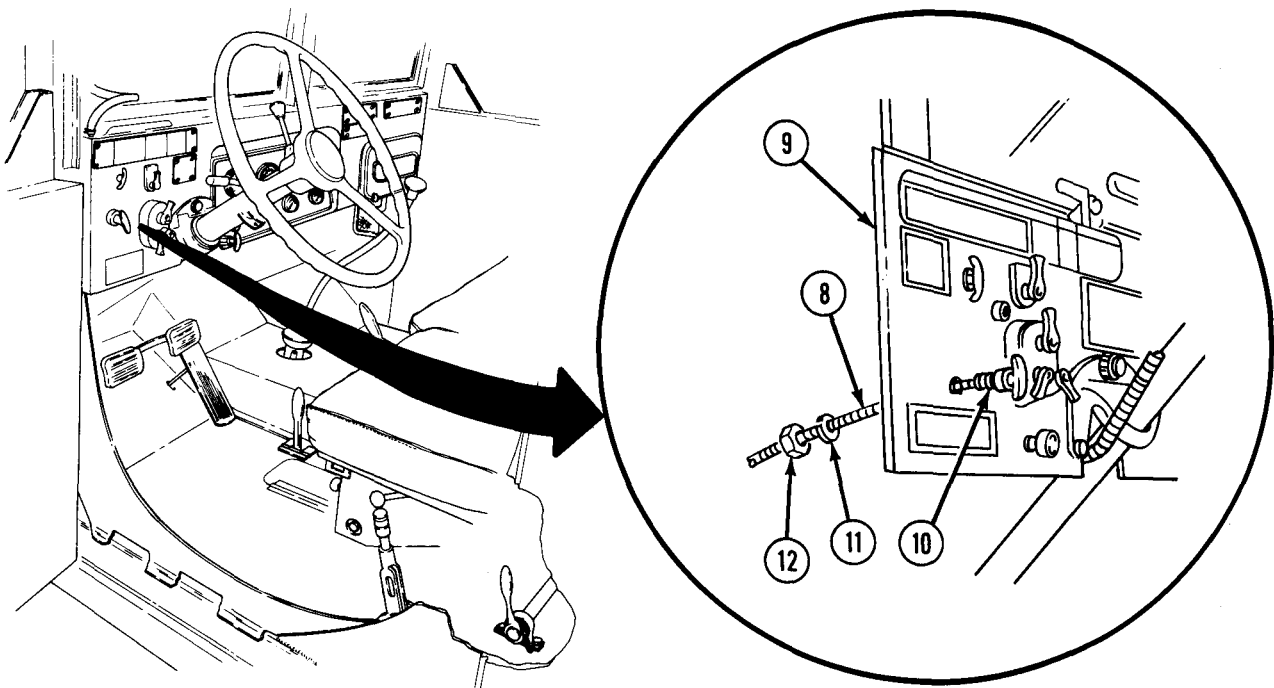
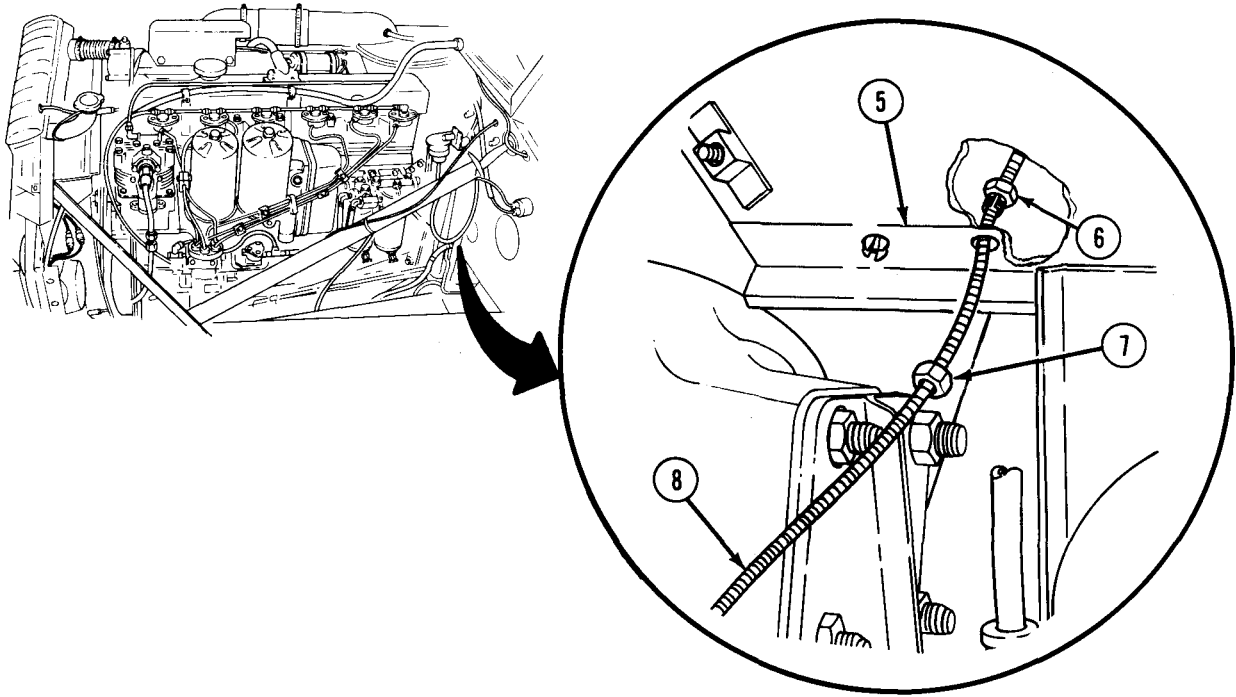

**3-35. HAND THROTTLE CONTROL CABLE MAINTENANCE (Contd)**

**b. Installation**

1. Install control cable (3) through instrument panel (2) and install new lockwasher (5) and nut (6) on hand throttle control (4).
2. Position screw (8) on end of cable (3). Push cable (3) through hole in cab floor (7).
3. Position nut (9) on end of cable (3) and install nut (9) on screw (8) and cab floor (7). Do not tighten nut (9).
4. Install control wire (13) through accelerator rod flange (12).
5. Install connector (11) and screw (10) on control wire (13). Do not tighten screw (10).

**c. Adjustment**

1. Push HAND THROTTLE control (4) all the way in.

**NOTE**

Assistant will help with step 2.

2. Hold accelerator pedal (1) down.
3. Position control cable (3) through floor (7) until distance between end of control cable (3) and accelerator rod flange (12) is approximately 0.5 in. (13 mm).
4. Release accelerator pedal (1).

**NOTE**

Assistant will help with step 5.

5. Tighten screw (8) and nut (9).
6. Position connector (11) next to accelerator rod flange (12) and tighten screw (10) on control wire (13). Bend end of control wire (13) up.

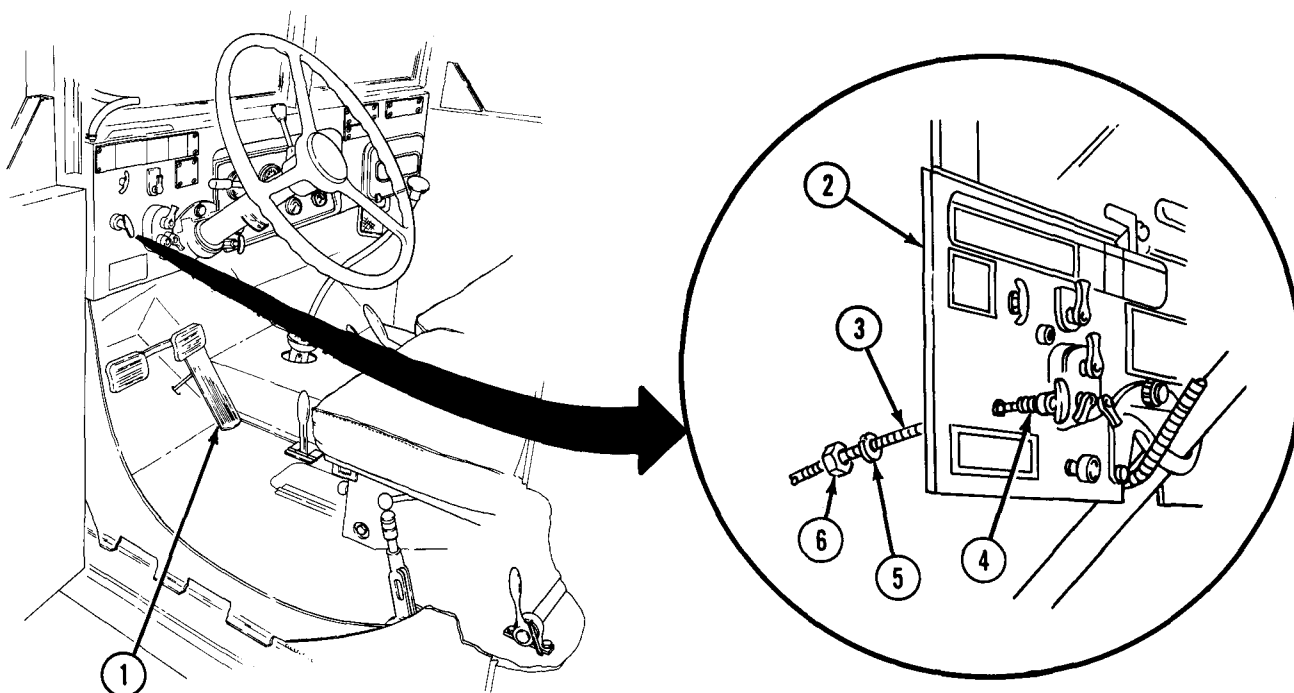

3-35. HAND THROTTLE CONTROL CABLE MAINTENANCE (Contd)

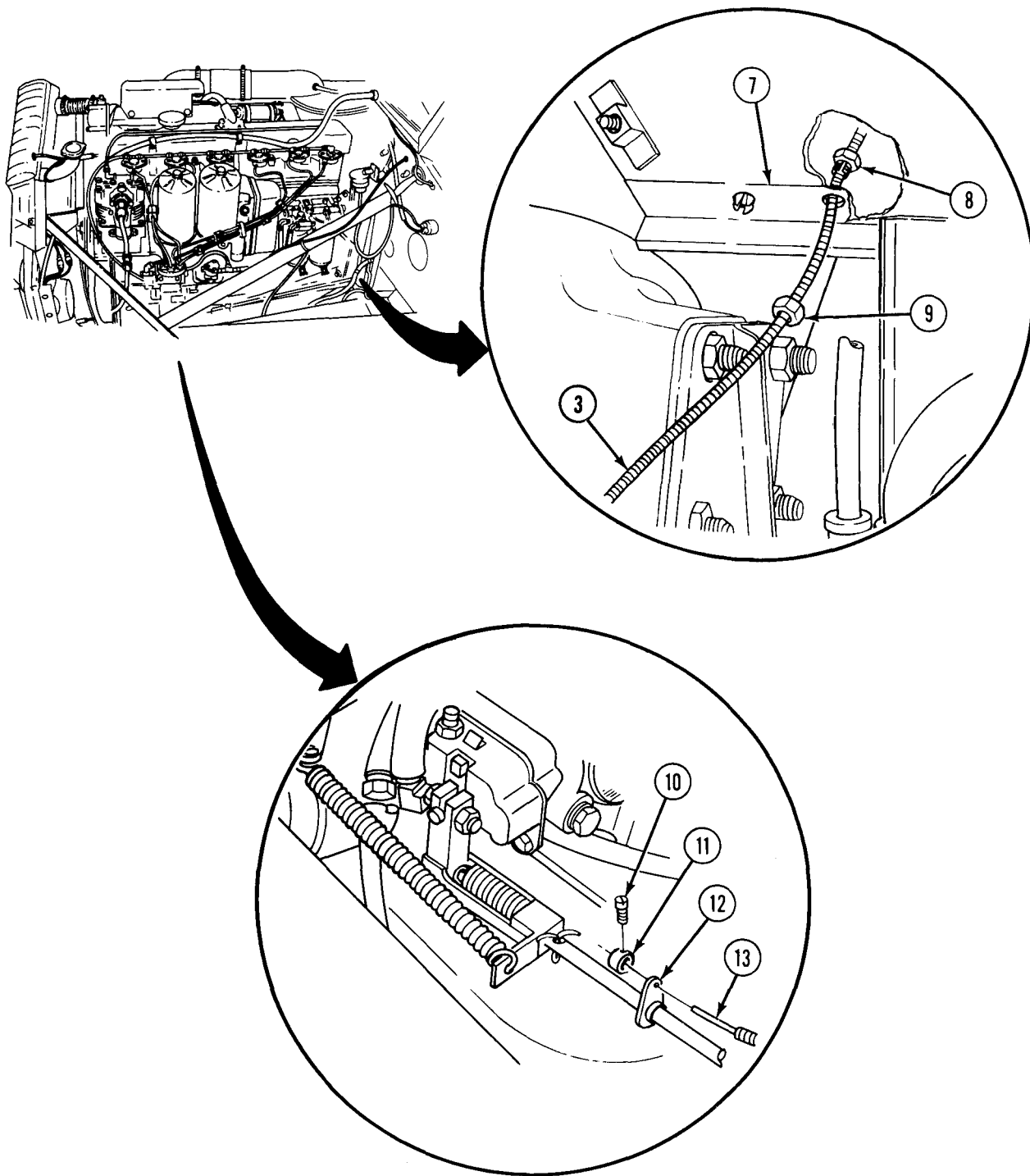

FOLLOW-ON TASK: Start and stop engine (TM 9-2320-361-10).



Section VIII. EXHAUST SYSTEM MAINTENANCE

**3-36. EXHAUST SYSTEM MAINTENANCE INDEX**

PARA. NO.	TITLE	PAGE NO.
3-37.	Exhaust System Replacement	3-82
3-38.	Exhaust System Replacement (M50A2 and M50A3)	3-86

**3-37. EXHAUST SYSTEM REPLACEMENT**

This task covers:

**a. Removal**

**b. Installation**

**INITIAL SETUP:**

APPLICABLE MODELS

All except M50A2, M50A3

EQUIPMENT CONDITION

Air cleaner element removed (para. 3-14).

MATERIALS/PARTS

Four gaskets  
Ten locknuts  
Two lockwashers

GENERAL SAFETY INSTRUCTIONS

Do not touch hot exhaust system components with bare hands.

REFERENCES (TM)

TM 9-2320-361-10  
TM 9-2320-361-20P

**WARNING**

Do not touch hot exhaust system components with bare hands.  
Severe injury to personnel will result.

**a. Removal**

1. Remove locknut (13) and screw (7) from coupling (14). Discard locknut (13).
2. Disconnect elbow (9) from flex tube (15), and remove coupling (14) and gasket (8) from elbow (9). Discard gasket (8).
3. Loosen clamp (11) and remove elbow (9), clamp (11), and gasket (10) from turbocharger (12). Discard gasket (10).
4. Remove locknut (22) and screw (21) from coupling (23), and remove flex tube (15), coupling (23), and gasket (24) from exhaust pipe (29). Discard gasket (24) and locknut (22).
5. Remove locknut (2) and screw (38) from coupling (39). Discard locknut (2).
6. Remove stack pipe (1), coupling (39), and gasket (40) from exhaust pipe (29). Discard gasket (40).
7. Remove four locknuts (4), screws (37), two clamps (3), and exhaust shield (36) from exhaust pipe (29). Discard locknuts (4).
8. Remove two locknuts (30), washers (31), screws (34), washers (33), and cover plates (18) from fender (32). Discard locknuts (30).

### 3-37. EXHAUST SYSTEM REPLACEMENT (Contd)

9. Remove two nuts (5), lockwashers (6), U-bolt (35), and clamp (17) from exhaust pipe (29) and bracket (16). Discard lockwashers (6).
10. Remove locknut (20), washer (19), screw (28), washer (27), and clamp (26) from exhaust pipe (29) and bracket (25). Discard locknut (20).
11. Remove exhaust pipe (29) from fender (32).

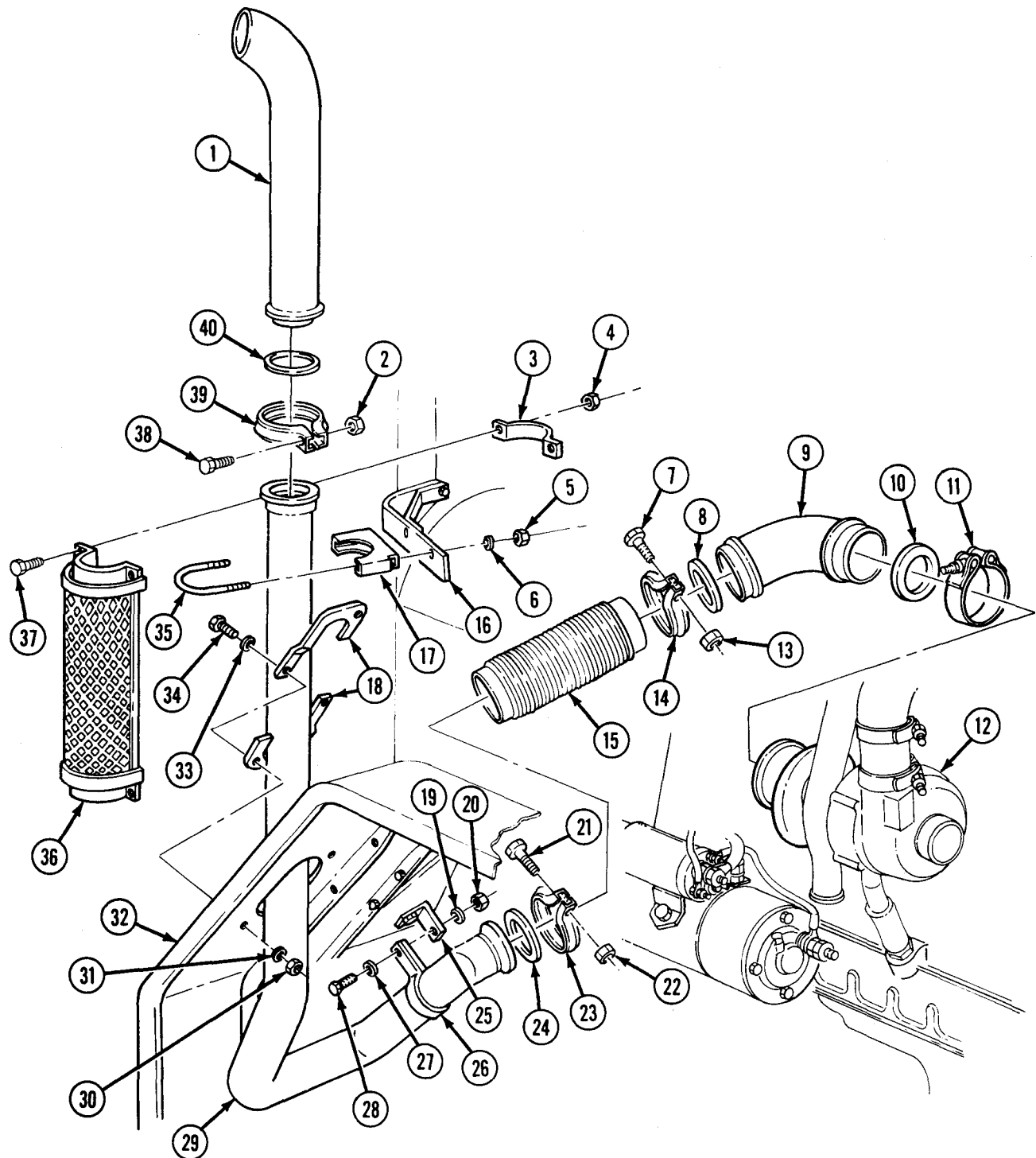

### 3-37. EXHAUST SYSTEM REPLACEMENT (Contd)

#### b. Installation

1. Install exhaust pipe (29) on fender (32).
3. Install exhaust pipe (29) on bracket (16) with U-bolt (35), clamp (17), two new lockwashers (6), and nuts (5).
2. Install exhaust pipe (29) on bracket (25) with clamp (26), washer (27), screw (28), washer (19), and new locknut (20).
4. Install cover plates (18) on fender (32) with two washers (33), screws (34), washers (31), and two new locknuts (30).
5. Install exhaust shield (36) on exhaust pipe (29) with two clamps (3), four screws (37), and new locknuts (4).
6. Install new gasket (40) and stack pipe (1) on exhaust pipe (29) with coupling (39), screw (38), and new locknut (2). Do not tighten locknut (2).
7. Position outlet of stack pipe (1) outward and approximately 45° to the rear of vehicle. Tighten coupling (39).
8. Install new gasket (24) and flex tube (15) on exhaust pipe (29) with coupling (23), screw (21), and new locknut (22). Do not tighten locknut (22).
9. Install new gasket (10) and elbow (9) on turbocharger (12) with clamp (11). Do not tighten clamp (11).
10. Install new gasket (8) and flex tube (15) on elbow (9) with coupling (14), screw (7), and new locknut (13). Tighten coupling (14).
11. Tighten clamp (11) and coupling (23).

**3-37. EXHAUST SYSTEM REPLACEMENT (Contd)**

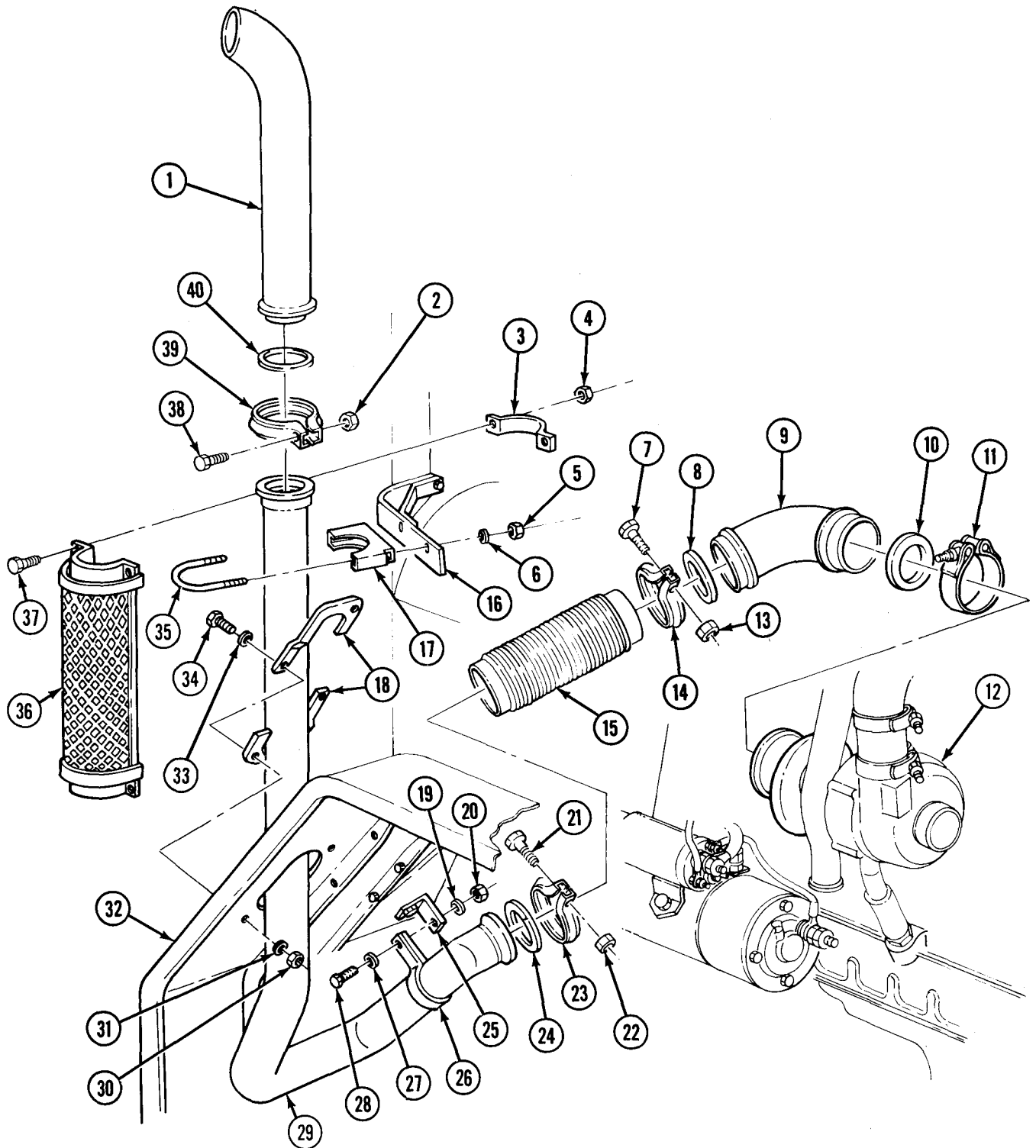

- FOLLOW-ON TASKS:**
- Install air cleaner element (para. 3-14).
  - Start engine (TM 9-2320-361-10) and check for exhaust leaks.

**3-38. EXHAUST SYSTEM REPLACEMENT (M50A2 AND M50A3)**

This task covers:

**a. Removal**

**b. Installation**

**INITIAL SETUP:**

APPLICABLE MODELS

M50A2, M50A3

MATERIALS/PARTS

Seven gaskets  
 Eighteen locknuts  
 Two lockwashers

REFERENCES (TM)

TM 9-2320-361-10  
 TM 9-2320-361-20P

EQUIPMENT CONDITION

Air cleaner element removed (para. 3-14).

GENERAL SAFETY INSTRUCTIONS

Do not touch hot exhaust system components with bare hands.

**a. Removal**

**WARNING**

Do not touch hot exhaust system components with bare hands; injury to personnel will result.

1. Remove locknut (15), screw (9), and coupling (16) from flex tube (17) and elbow (11). Discard locknut (15).
2. Remove locknut (24), screw (22), coupling (23), flex tube (17), and gaskets (10) and (25) from elbow (11) and Y-pipe (31). Discard locknut (24) and gaskets (10) and (25).
3. Loosen clamp (13) and remove elbow (11), clamp (13), and gasket (12) from turbocharger (14). Discard gasket (12).
4. Remove locknut (43), screw (2), and exhaust stack shutoff (1) from exhaust pipe (3). Discard locknut (43).
5. Remove locknut (4), screw (40), clamp (41), exhaust pipe (3), and gasket (42) from Y-pipe (31). Discard locknut (4) and gasket (42).
6. Remove four locknuts (6), screws (39), two clamps (5), and exhaust shield (38) from Y-pipe (31). Discard locknuts (6).
7. Remove two nuts (8), lockwashers (18), U-bolt (37), and clamp (19) from Y-pipe (31) and bracket (7). Discard lockwashers (18).
8. Remove two locknuts (32), washers (33), screws (36), washers (35), and cover plates (20) from fender (34). Discard locknuts (32).
9. Remove locknut (21), washer (26), screw (30), washer (29), clamp (28), and Y-pipe (31) from bracket (27). Discard locknut (21).

**3-38. EXHAUST SYSTEM REPLACEMENT (M50A2 AND M50A3) (Contd)**

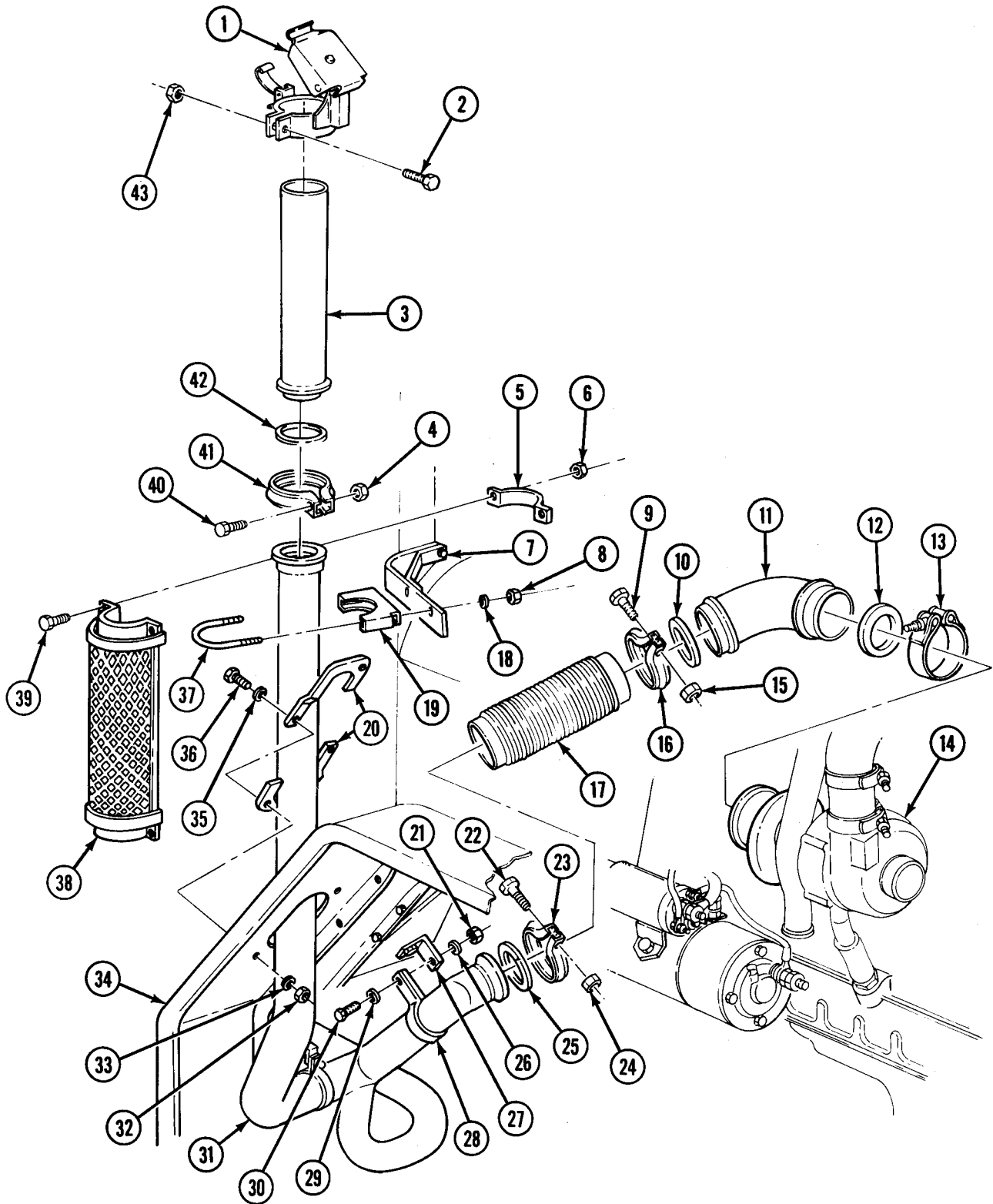

**3-38. EXHAUST SYSTEM REPLACEMENT (M50A2 AND M50A3) (Contd)**

10. Remove locknut (10), screw (2), coupling (3), and gasket (4) from exhaust pipe (1) and Y-pipe (5). Discard locknut (10) and gasket (4),
11. Remove locknut (9), screw (6), clamp (7), and Y-pipe (5) from bracket (8). Discard locknut (9).
12. Remove locknut (17), screw (14), coupling (15), exhaust pipe (1), and gasket (16) from exhaust pipe (18). Discard locknut (17) and gasket (16).
13. Remove four locknuts (19), screws (11), exhaust pipe (18), and gasket (13) from manifold (12). Discard locknuts (19) and gasket (13).

**b. Installation**

1. Install new gasket (13) and exhaust pipe (18) on exhaust manifold (12) with four screws (11) and new locknuts (19).
2. Install new gasket (16) and exhaust pipe (1) on exhaust pipe (18) with coupling (15), screw (14), and new locknut (17).
3. Install Y-pipe (5) on bracket (8) with clamp (7), screw (6), and new locknut (9). Do not tighten locknut (9).
4. Install Y-pipe (5) on exhaust pipe (1) with new gasket (4), coupling (3), screw (2), and new locknut (10).
5. Tighten locknut (9).

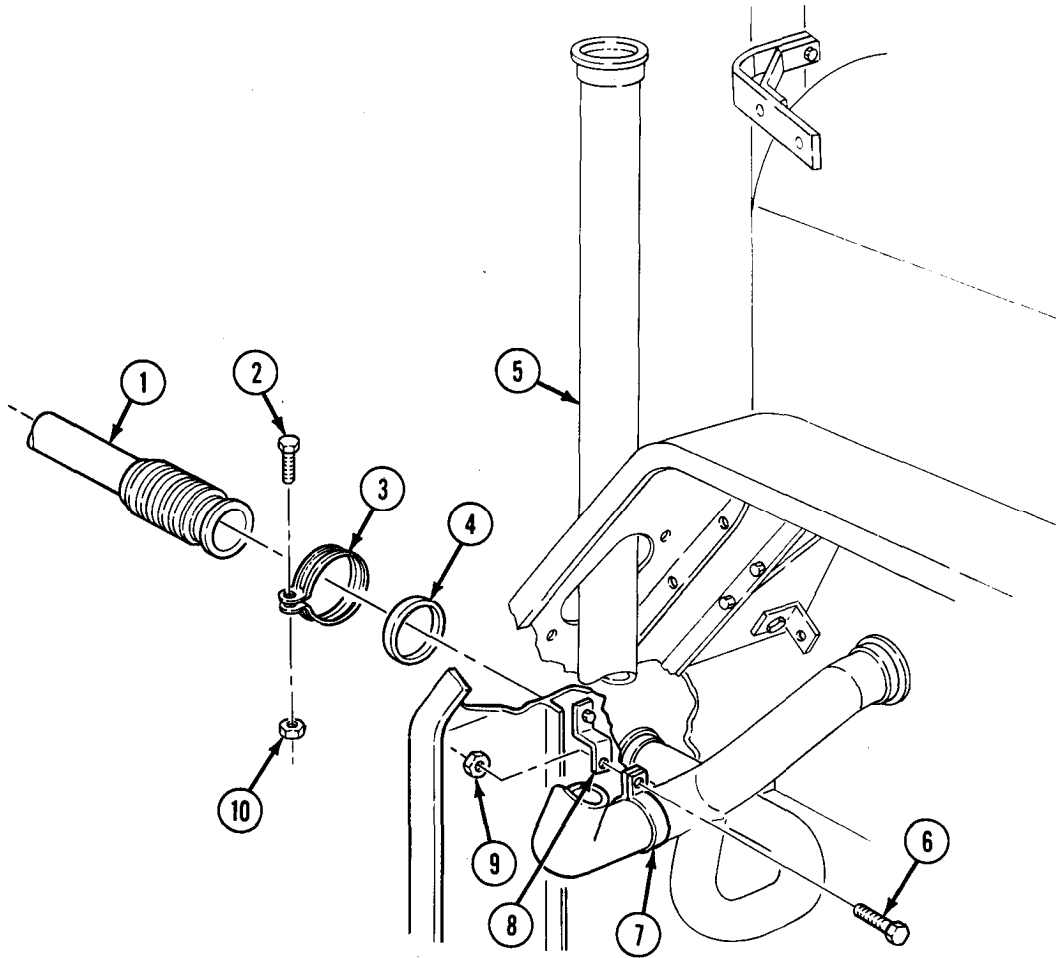

3-38. EXHAUST SYSTEM REPLACEMENT (M50A2 AND M50A3) (Contd)

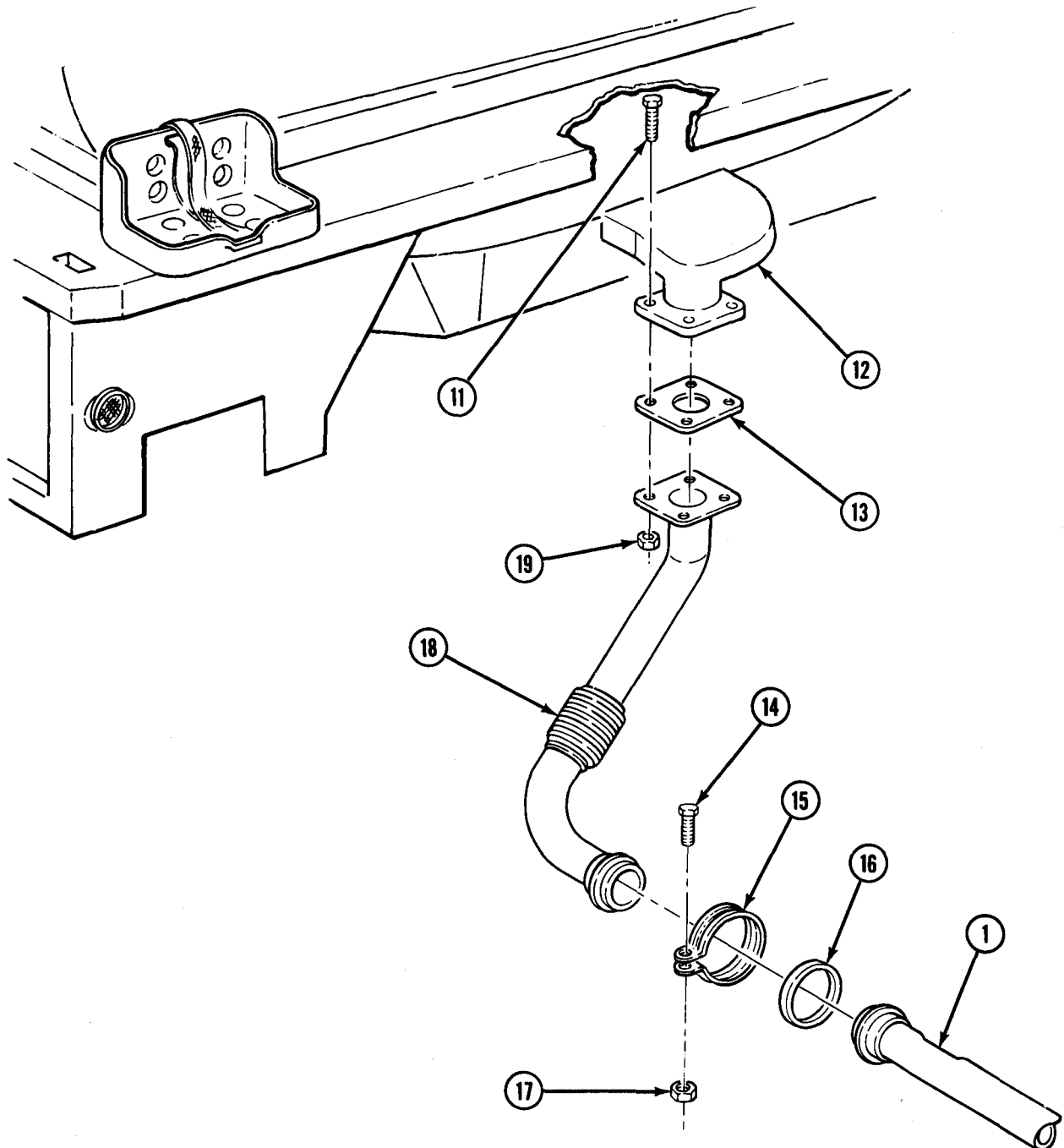



**3-38. EXHAUST SYSTEM REPLACEMENT (M50A2 AND M50A3) (Contd)**

6. Install new gasket (12) and elbow (11) on turbocharger (14) with clamp (13). Do not tighten clamp (13).
7. Install new gasket (10) and flex tube (17) on elbow (11) with coupling (16), screw (9), and new locknut (15).
8. Install new gasket (25) and Y-pipe (31) on flex tube (17) with coupling (23), screw (22), and new locknut (24).
9. Install clamp (28) and Y-pipe (31) on bracket (27) with washer (29), screw (30), washer (26), and new locknut (21).
10. Install two cover plates (20) on fender (34) with two washers (35), screws (36), washers (33), and new locknuts (32).
11. Tighten clamp (13) on elbow (11).
12. Install U-bolt (37) and clamp (19) on Y-pipe (31) and bracket (7) with two new lockwashers (18) and nuts (8).
13. Install exhaust shield (38) on Y-pipe (31) with two clamps (5), four screws (39), and new locknuts (6).
14. Install new gasket (42) and exhaust pipe (3) on Y-pipe (31) with coupling (41), screw (40), and new locknut (4).
15. Install exhaust stack shutoff (1) on exhaust pipe (3) with screw (2) and new locknut (43). Do not tighten locknut (43).
16. Position exhaust stack shutoff (1) so exhaust gases are directed away from and toward rear of vehicle at approximately a 45° angle.
17. Tighten locknut (43) on exhaust stack shutoff (1).

**3-38. EXHAUST SYSTEM REPLACEMENT (M50A2 AND M50A3) (Contd)**

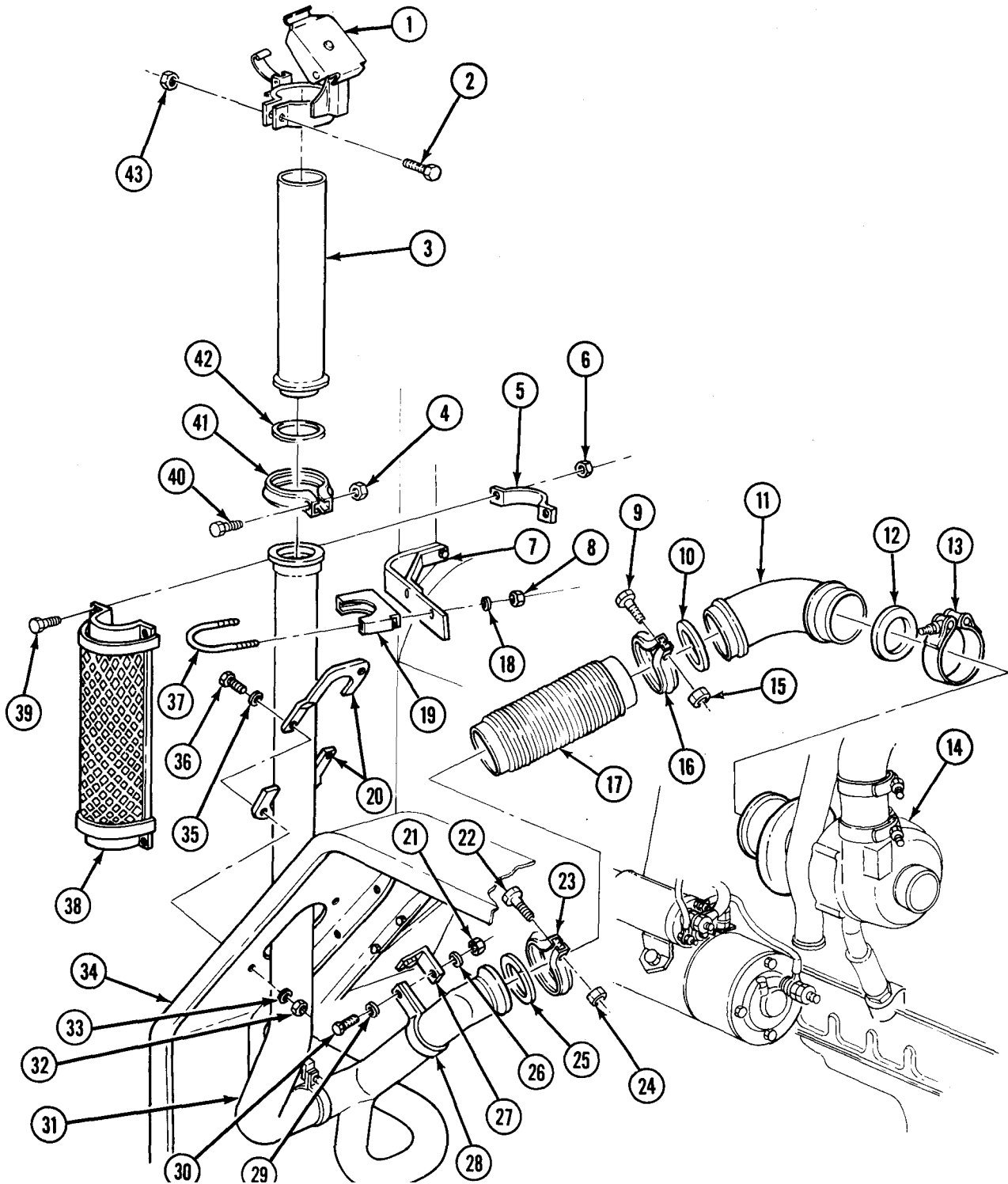

- FOLLOW-ON TASKS:
- Install air cleaner element (para. 3-14).
  - Start engine (TM 9-2320-361-10) and check for exhaust leaks.

Section IX. COOLING SYSTEM MAINTENANCE

**3-39. COOLING SYSTEM MAINTENANCE INDEX**

PARA. NO.	TITLE	PAGE NO.
3-40.	Fan Replacement	3-92
3-41.	Cooling System Servicing	3-94
3-42.	Radiator and Brackets Replacement	3-96
3-43.	Upper and Lower Radiator Hose Replacement	3-100
3-44.	Personnel Heater Inlet and Outlet Hose Replacement	3-102
3-45.	Water Manifold and Hose Replacement	3-103
3-46.	Thermostat, Housing, and Hose Replacement	3-104
3-47.	Water Pump Housing and Water Pump Replacement	3-106
3-48.	Oil Cooler Tube and Hoses Replacement	3-108

**3-40. FAN REPLACEMENT**

This task covers:

**a. Removal**

**b. Installation**

**INITIAL SETUP:**

APPLICABLE MODELS

All

MATERIALS/PARTS

Four lockwashers

REFERENCES (TM)

TM 9-2320-361-10

TM 9-2320-361-20P

EQUIPMENT CONDITION

- Parking brake set (TM 9-2320-361-10).
- Hood raised and secured (TM 9-2320-361-10).
- Battery ground cable disconnected (para. 4-48).
- Upper radiator hose removed (para. 3-43).

**a. Removal**

**CAUTION**

Radiator core is easily damaged. Use care when working near or handling radiator.

1. Loosen two locknuts (6) and tilt radiator (5) away from engine.
2. Remove four screws (3) and lockwashers (2) from fan (1) and water pump pulley (4). Discard lockwashers (2).
3. Carefully remove fan (1) from water pump pulley (4).

**b. Installation**

1. Install fan (1) on water pump pulley (4) with four new lockwashers (2) and screws (3).
2. Push radiator (5) back in position and tighten locknuts (6).

**3-40. FAN REPLACEMENT (Contd)**

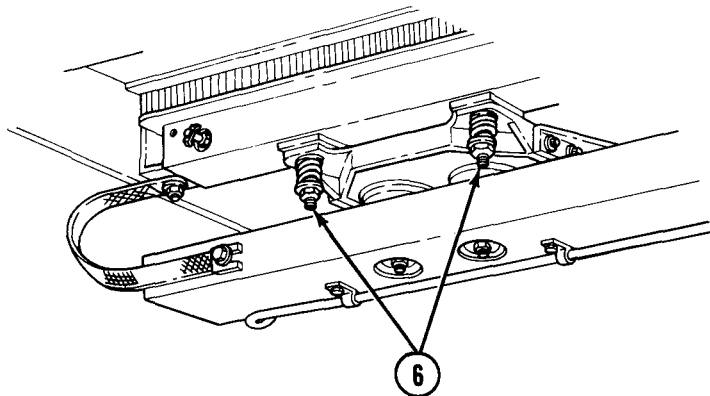
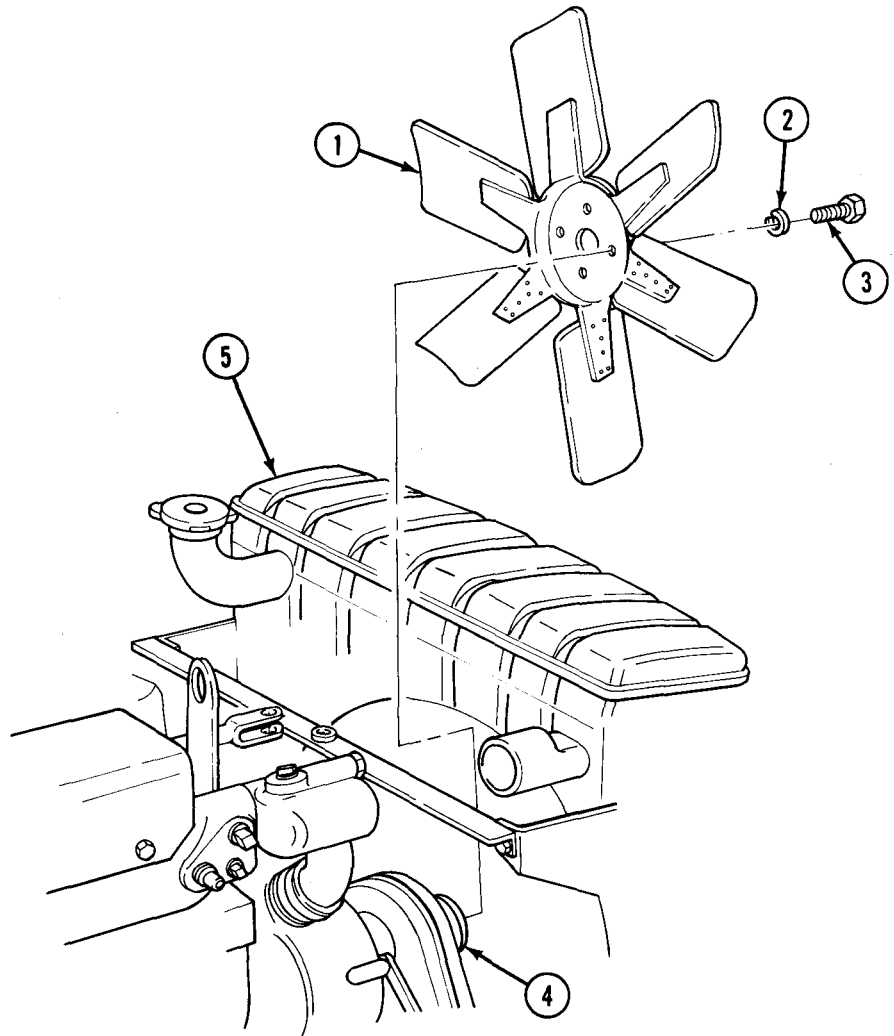

**FOLLOW-ON TASKS:**

- Install upper radiator hose (para. 3-43).
- Connect battery ground cable (para. 4-48).

### 3-41. COOLING SYSTEM SERVICING

This task covers:

a. Draining System

b. Cleaning and Flushing System

c. Filling System

**INITIAL SETUP:**

APPLICABLE MODELS

All

MATERIALS/PARTS

Antifreeze (Appendix C, Item 6)

Cleaning compound kit (Appendix C, Item 10)

REFERENCES (TM)

TM 9-2320-361-10

TM 9-2320-361-20P

EQUIPMENT CONDITION

- Parking brake set (TM 9-2320-361-10).
- Hood raised and secured (TM 9-2320-361-10).
- Battery ground cable disconnected (para. 4-48).

GENERAL SAFETY INSTRUCTIONS

Do not remove radiator cap if engine is hot.

#### a. Draining System

**WARNING**

Do not remove radiator cap if engine is hot. Steam or hot coolant under pressure may cause injury to personnel.

1. Turn radiator cap (1) to first stop. Allow any pressure to escape.
2. Remove radiator cap (1) by pressing down and continue turning counterclockwise. Lift off radiator cap (1) from filler neck (2).

**NOTE**

Have drainage containers ready to catch coolant.

3. Open engine block draincock (5) and radiator draincock (4).
4. Close engine block draincock (5) and radiator draincock (4).

#### b. Cleaning and Flushing System

Following cleaning and flushing instructions included in cleaning compound kit, and clean and flush radiator (3) and cooling system.

#### c. Filling System

**NOTE**

Capacity of cooling system is 32 quarts (30.3 liters).

1. Fill cooling system with required amount of antifreeze (Table 3-1).
2. Add water to 1 in. (2.45 cm) below top of filler neck (2).
3. Install radiator cap (1) on filler neck (2), start engine (TM 9-2320-361-10), and allow engine to reach normal operating temperature.
4. Stop engine (TM 9-2320-361-10) and allow engine to cool.

**WARNING**

Do not remove radiator cap if engine is hot. Steam or hot coolant under pressure may cause injury to personnel.

5. Remove radiator cap (1) from filler neck (2) and check level of coolant in radiator (3). Add water if necessary.

**3-41. COOLING SYSTEM SERVICING (Contd)**

- 6. Check antifreeze solution for required lowest expected ambient temperature with optical antifreeze/battery tester (Table 3-1).
- 7. Install radiator cap (1) on filler neck (2).

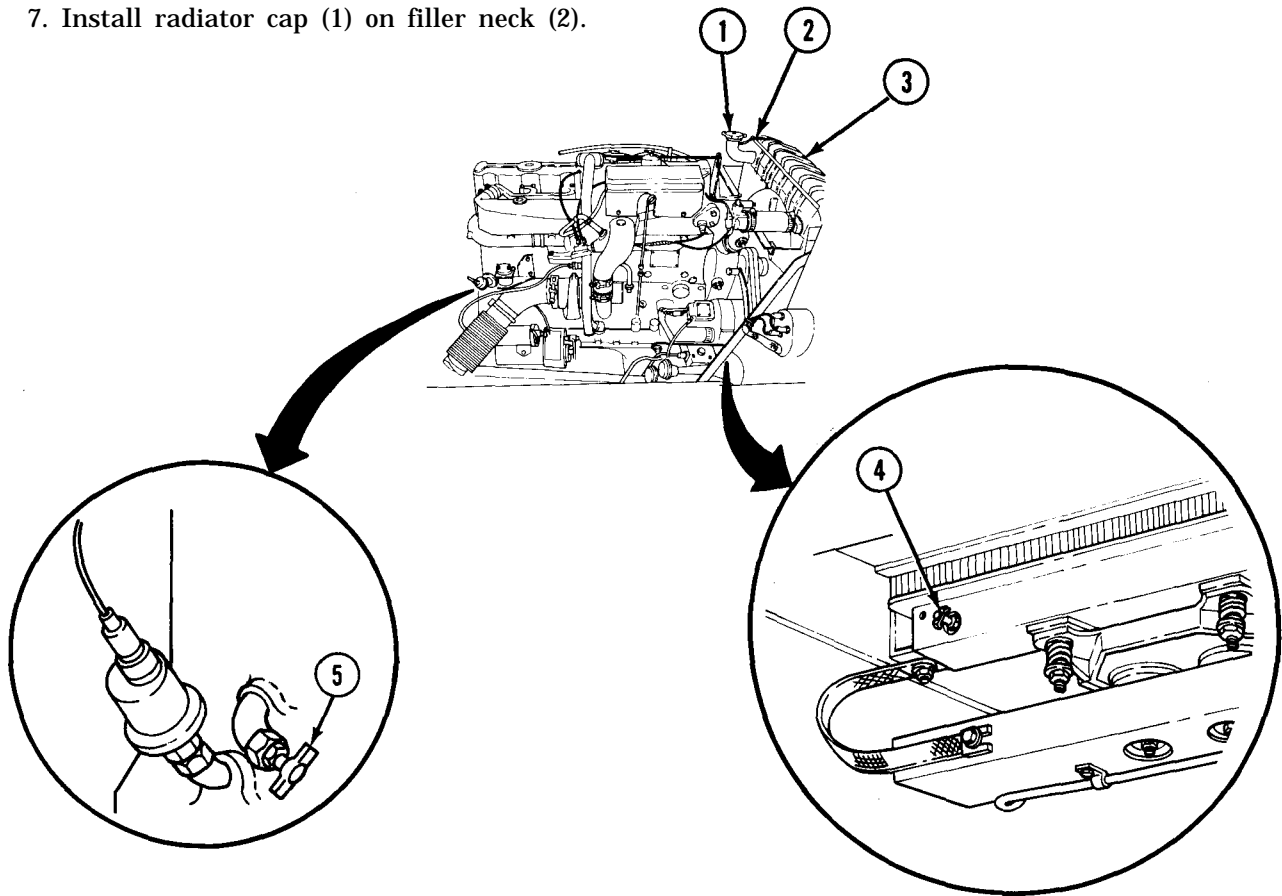

Table 3-1. Guide for Preparation of Antifreeze Solutions

ETHYLENE-GLYCOL -60°F (-51 °C) INHIBITED MIL-A-46153			
LOWEST EXPECTED AMBIENT TEMPERATURE		QUARTS OF ANTIFREEZE REQUIRED	ARCTIC GRADE ANTIFREEZE -90°F (-68°C) MIL-A-11755
°F	°C		
+20	-7	9	Freezing point of -90°F (-68°C). Issued ready for use and must not be mixed with any other liquid.
+10	-12	11-3/4	
0	-18	16	
-10	-23	19	
-20	-29	20-1/2	
-30	-34	23-1/2	
-40	-40	25	
-50	-46	26-1/2	
-55	-48	28	
Below -60	Below -51	Use arctic grade antifreeze (-90°F) (-68°C)	

FOLLOW-ON TASK: Connect battery ground cable (para. 4-48).

**3-42. RADIATOR AND BRACKETS REPLACEMENT**

This task covers:

**a. Removal**

**b. Installation**

**INITIAL SETUP:**

APPLICABLE MODELS

All

MATERIALS/PARTS

Ten locknuts  
 Lockwasher  
 Antifreeze (Appendix C, Item 6)

PERSONNEL REQUIRED

Two

REFERENCES (TM)

TM 9-2320-361-10  
 TM 9-2320-361-20P

EQUIPMENT CONDITION

- Parking brake set (TM 9-2320-361-10).
- Hood raised and secured (TM 9-2320-361-10).
- Upper and lower radiator hose removed (para. 3-43).
- Brushguard removed (para. 10-8).
- Fan removed (para. 3-40).

**a. Removal**

1. Remove locknut (8), washer (9), ground strap (10), lockwasher (11), and screw (1) from radiator (2). Discard locknut (8) and lockwasher (11).
2. Remove two locknuts (6), washers (5), springs (7), and washers (4) from radiator mounting studs (3). Discard locknuts (6).

CAUTION

Radiator core is easily damaged. Use care when working near or handling radiator.

3. Remove locknut (15), screw (12), and rod assembly (14) from bracket (13). Discard locknut (15).

**NOTE**

Assistant will help with step 4.

4. Tilt radiator (2) forward and carefully lift out of vehicle.

**NOTE**

Perform step 5 only if radiator and draincock are damaged or if radiator is being replaced.

5. Remove radiator cap (16) and draincock (17) from radiator (2).
6. Remove two shims (18) from radiator mounting studs (3).
7. Remove two locknuts (24), screws (22), and support (21) from left bracket (23) and right bracket (20). Discard locknuts (24).
8. Remove four locknuts (25), screws (19), left bracket (23), and right bracket (20) from radiator (2). Discard locknuts (25).

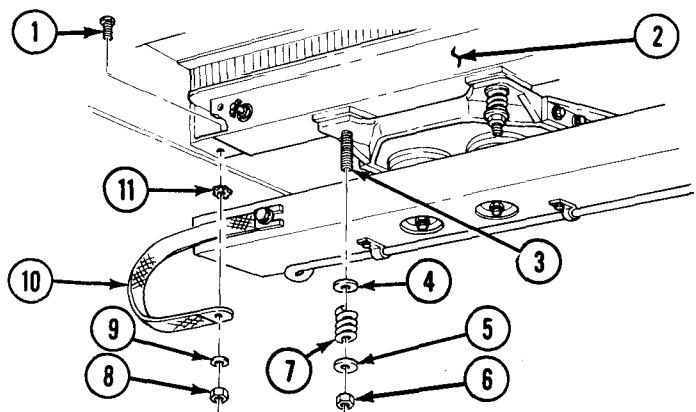
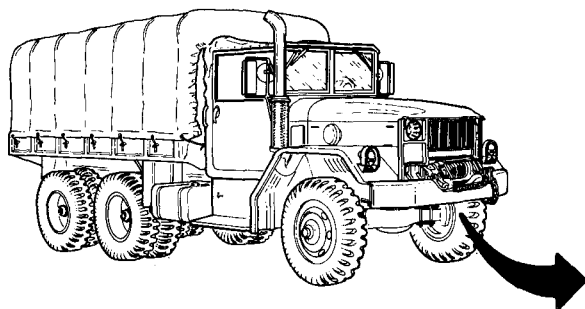

3-42. RADIATOR AND BRACKETS REPLACEMENT (Contd)

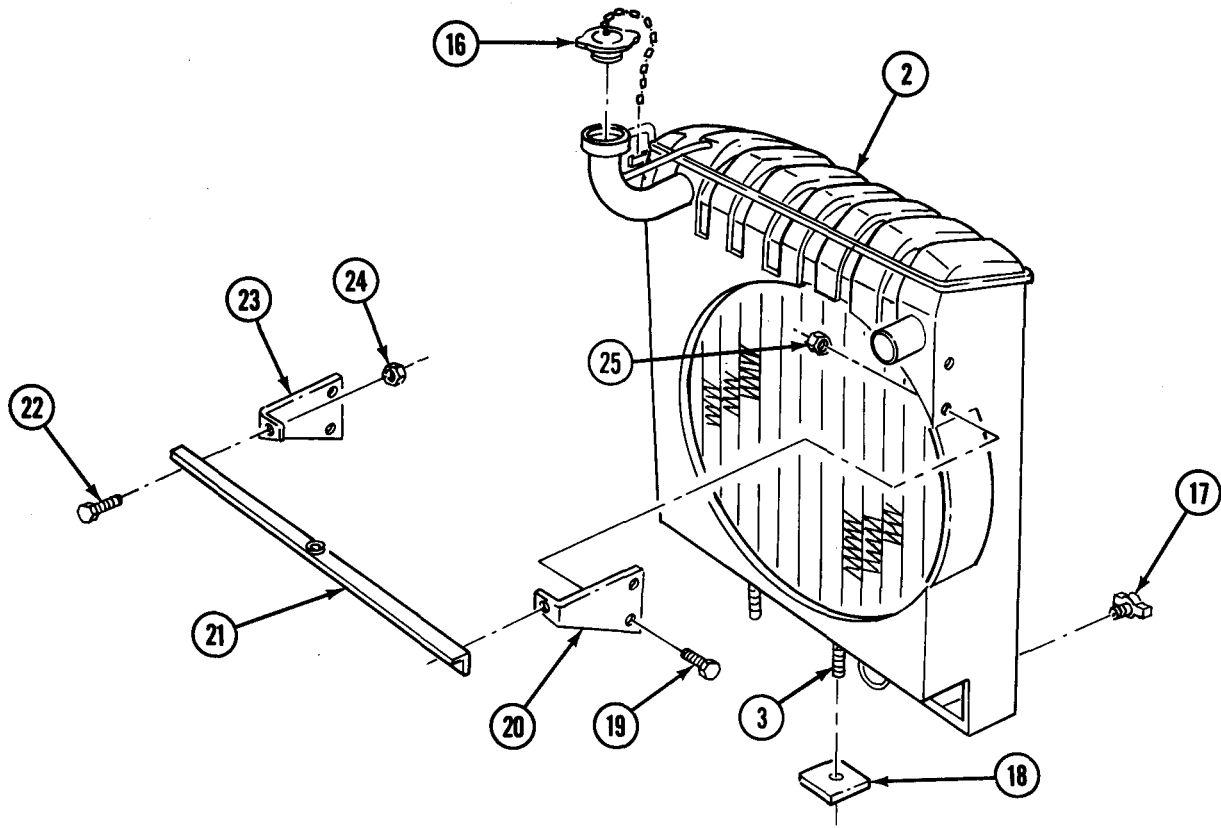
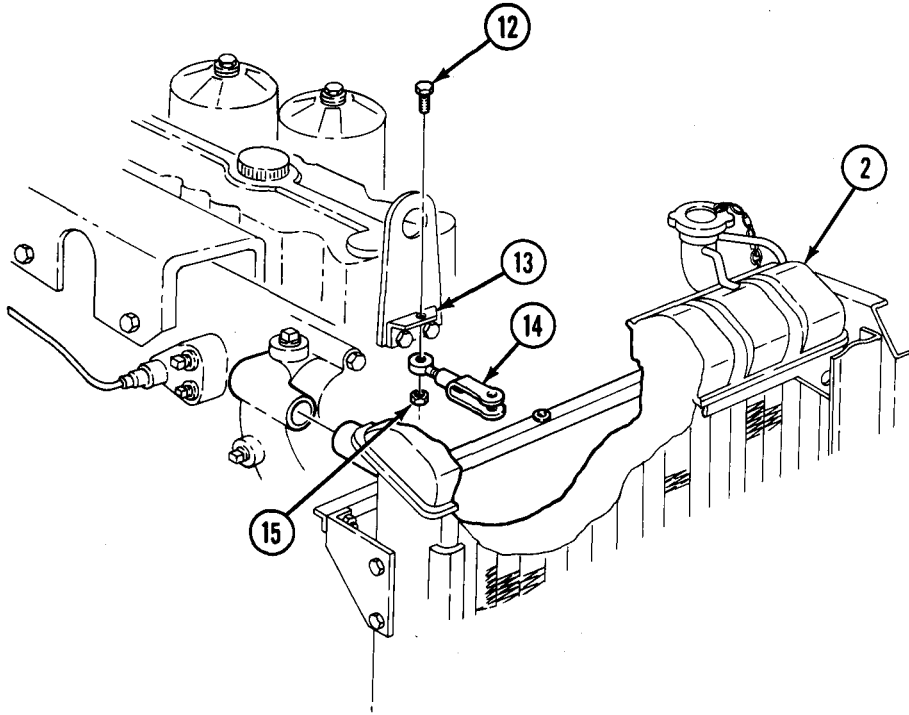



3-42. RADIATOR AND BRACKETS REPLACEMENT (Contd)

b. Installation

**NOTE**

Perform step 1 if radiator cap and draincock were removed.

1. Install radiator cap (1) and draincock (3) on radiator (2).
2. Install left bracket (10) and right bracket (7) on radiator (2) with four screws (6) and new locknuts (12).
3. Install support (8) on left bracket (10) and right bracket (7) with two screws (9) and new locknuts (11).
4. Install two shims (4) on radiator mounting studs (5).

**CAUTION**

Radiator core is easily damaged. Use care when working near or handling radiator.

**NOTE**

Assistant will help with step 5.

5. Carefully install radiator (2) on vehicle.
6. Install rod assembly (15) on bracket (14) with screw (13) and new locknut (16).
7. Install two washers (18), springs (21), washers (19), and new locknuts (20) on radiator mounting studs (5). Do not fully compress springs (21).
8. Install ground strap (24) on radiator (2) with screw (17), new lockwasher (25), washer (23), and new locknut (22).

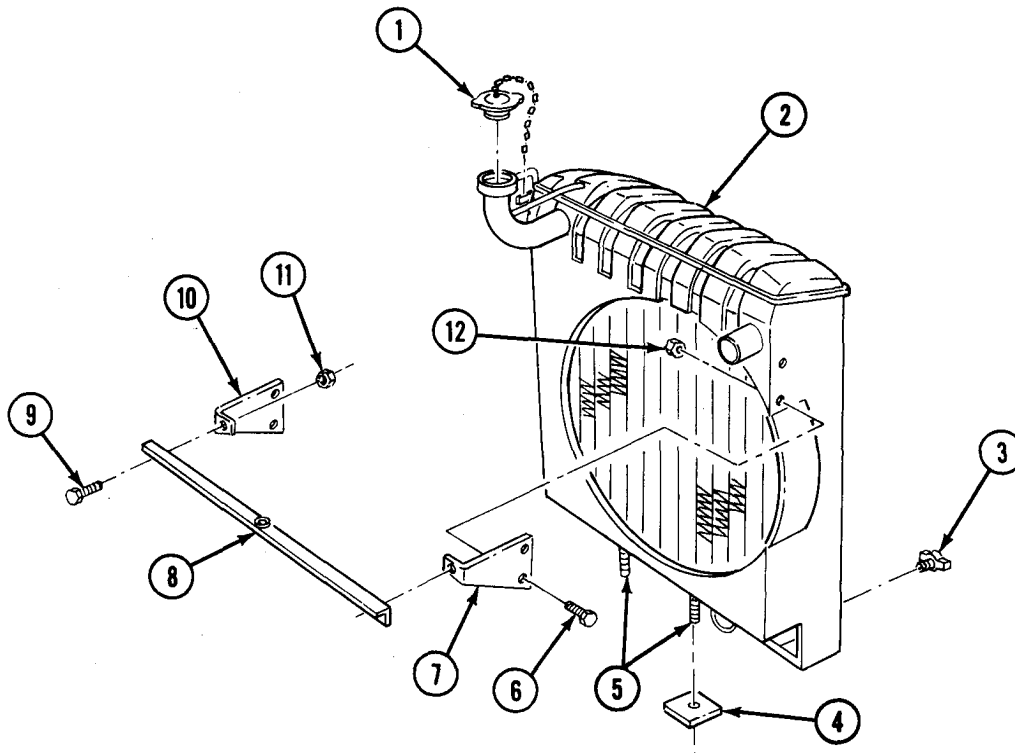

**3-42. RADIATOR AND BRACKETS REPLACEMENT (Contd)**

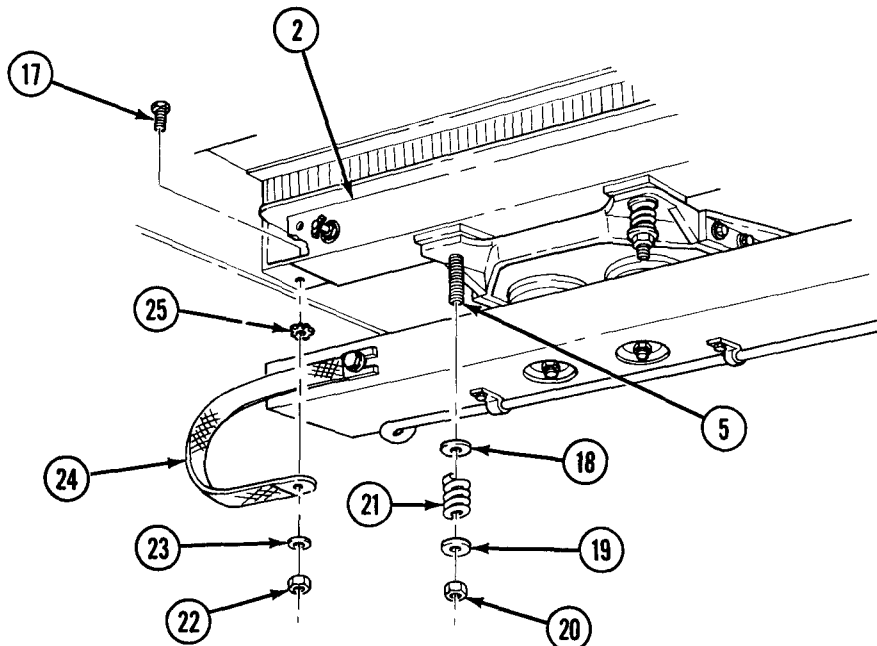
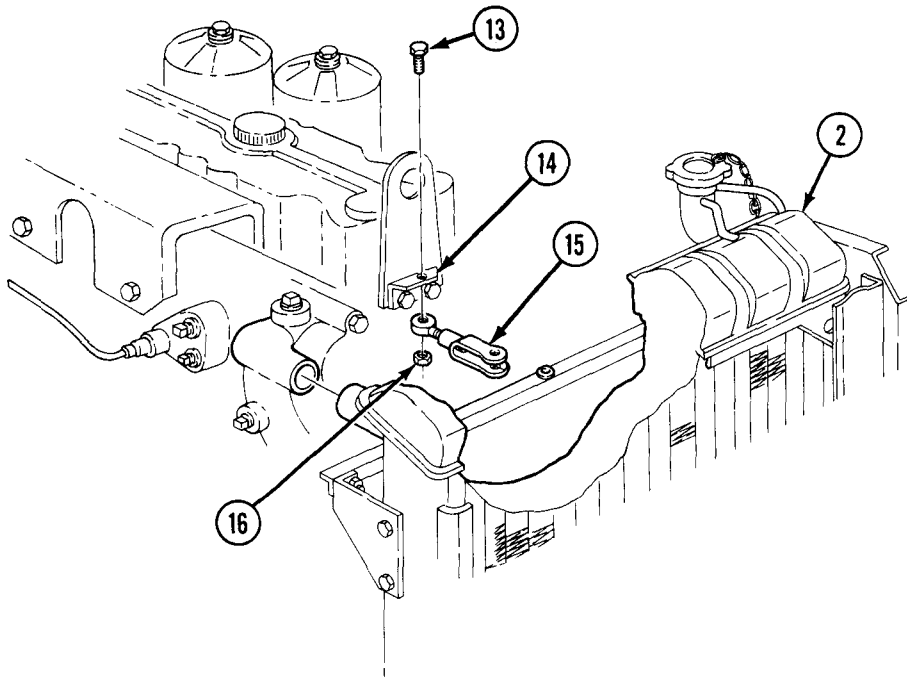

FOLLOW-ON TASKS: Ž Install fan (para. 3-40).  
 • Install brushguard (para. 10-8).  
 Ž Install upper and lower radiator hose (para. 3-43).

### 3-43. UPPER AND LOWER RADIATOR HOSE REPLACEMENT

This task covers:

- |                       |                            |
|-----------------------|----------------------------|
| a. Upper Hose Removal | c. Upper Hose Installation |
| b. Lower Hose Removal | d. Lower Hose Installation |

#### INITIAL SETUP:

##### APPLICABLE MODELS

All

##### MATERIALS/PARTS

Locknut

##### REFERENCES TM)

TM 9-2320-361-10  
TM 9-2320-361-20P

##### EQUIPMENT CONDITION

- Parking brake set (TM 9-2320-361-10).
- Hood raised and secured (TM 9-2320-361-10).
- Cooling system drained (lower hose) (para. 3-41).

#### a. Upper Hose Removal

##### NOTE

Have drainage container ready to catch coolant.

1. Remove locknut (6) and screw (1) from rod (7) and bracket (8). Discard locknut (6).
2. Loosen two clamps (2) on upper radiator hose (3).
3. Tilt radiator (4) forward and remove upper radiator hose (3) and two clamps (2) from radiator (4) and thermostat housing (5).

#### b. Lower Hose Removal

1. Loosen two clamps (9) on lower radiator hose (11).
2. Remove lower radiator hose (11) and two clamps (9) from radiator (4) and water pump housing (10),

#### c. Upper Hose Installation

1. Install upper radiator hose (3) on thermostat housing (5) and radiator (4) with two clamps (2). Do not tighten.
2. Tilt radiator (4) backward and install screw (1) new locknut (6), and rod (7) on bracket (8).
3. Tighten two clamps (2).

#### d. Lower Hose Installation

Install lower radiator hose (11) on water pump housing (10) and radiator (4) with two clamps (9). Tighten two clamps (9).

**3-43. UPPER AND LOWER RADIATOR HOSE REPLACEMENT (Contd)**

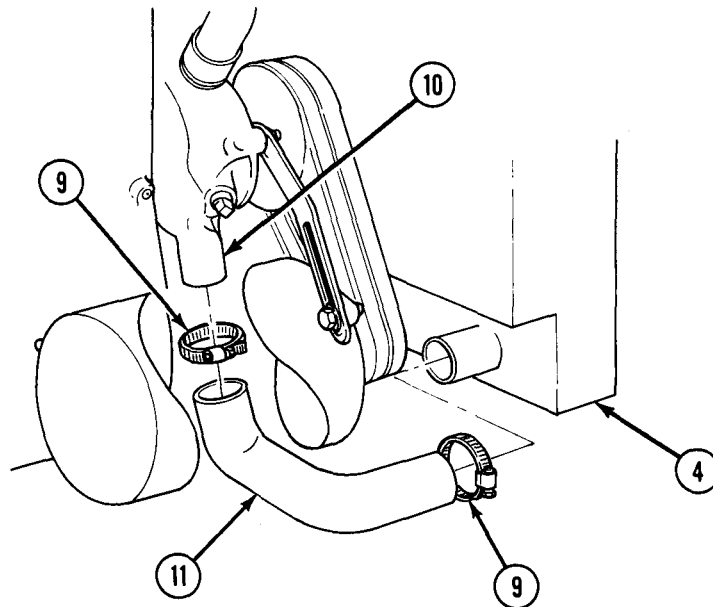
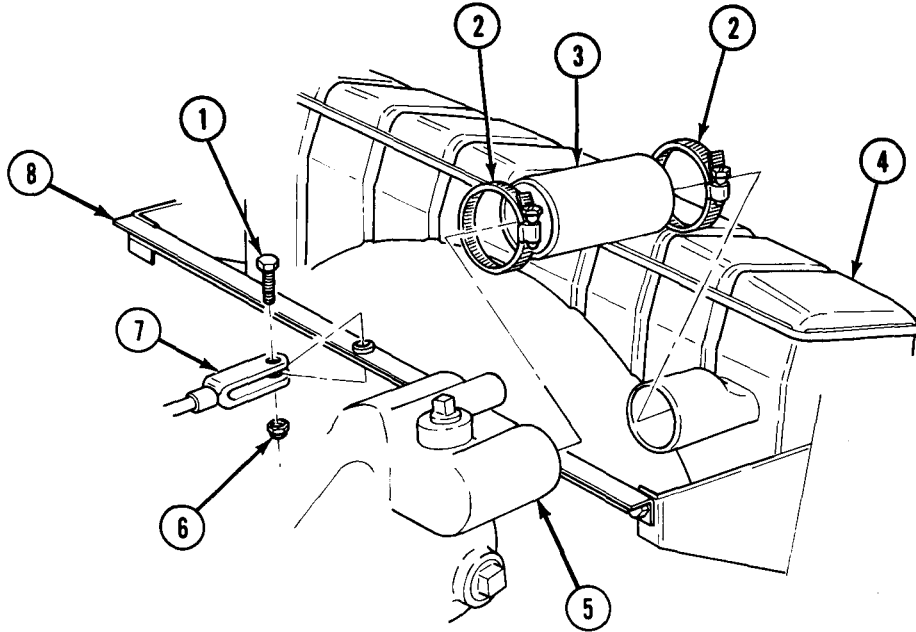

FOLLOW - ON TASK: Fill cooling system (para. 3-41).

### 3-44. PERSONNEL HEATER INLET AND OUTLET HOSE REPLACEMENT

This task covers:

a. Removal

b. Installation

INITIAL SETUP:

APPLICABLE MODELS

All

MATERIALS/PARTS

Locknut

REFERENCES (TM)

TM 9-2320-361-10

TM 9-2320-361-20P

EQUIPMENT CONDITION

•Parking brake set (TM 9-2320-361-10).

Z Hood raised and secured (TM 9-2320-361-10).

#### a. Removal

1. Remove locknut (10), screw (7), two washers (8), two clamps (1), inlet hose (3), and outlet hose (5) from bracket (2). Discard locknut (10).

#### NOTE

Have drainage container ready to catch coolant.

2. Loosen four clamps (4) and remove inlet hose (3) and outlet hose (5) from heater (6), water pump (9), and intake manifold (11).
3. Remove four clamps (4) and two clamps (1) from inlet hose (3) and outlet hose (5).

#### b. Installation

1. Install two clamps (1) and four clamps (4) on inlet hose (3) and outlet hose (5). Do not tighten clamps (4).
2. Install inlet hose (3) and outlet hose (5) on heater (6), water pump (9), and intake manifold (11). Tighten four clamps (4).
3. Install two clamps (1), inlet hose (3), and outlet hose (5) on bracket (2) with screw (7), two washers (8), and new locknut (10).

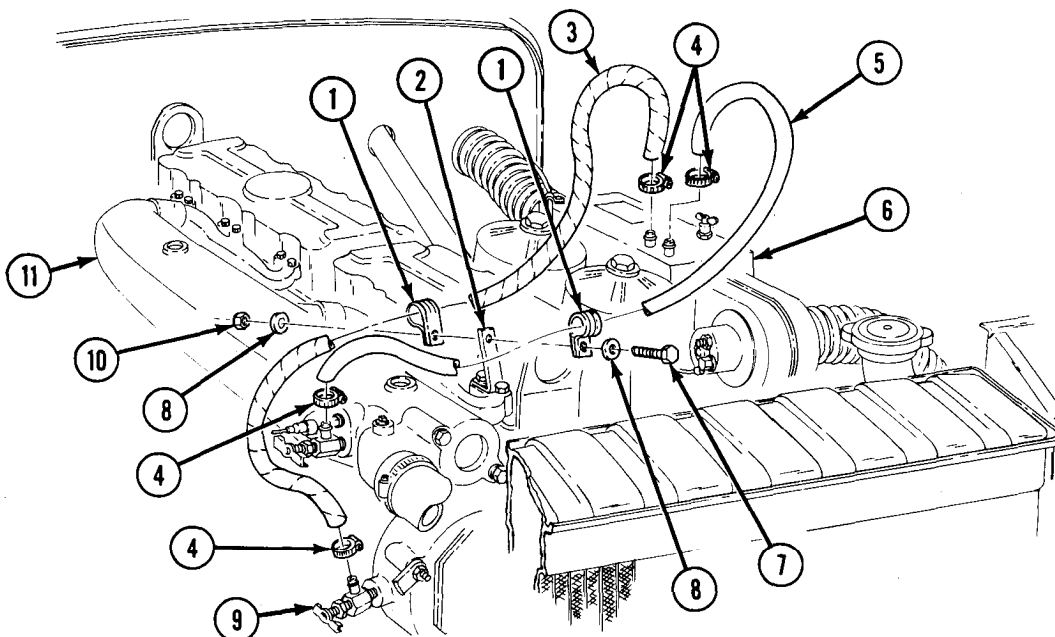

### 3-45. WATER MANIFOLD AND HOSE REPLACEMENT

This task covers:

a. Removal

b. Installation

INITIAL SETUP:

APPLICABLE MODELS

All

MATERIALS/PARTS

Six lockwashers

Three gaskets

REFERENCES (TM)

TM 9-2320-361-10

TM 9-2320-361-20P

EQUIPMENT CONDITION

- Parking brake set (TM 9-2320-361-10).
- Hood raised and secured (TM 9-2320-361-10).
- Manifold heater removed (uncovered) (para. 3-31).

#### a. Removal

#### NOTE

There are two water manifolds and hoses. Both are removed the same way.

1. Loosen two clamps (7) on hose (8).
2. Remove six screws (1) and lockwashers (2) from water manifold (3). Discard lockwashers (2).
3. Remove water manifold (3), three gaskets (4), hose (8), and two clamps (7) from cylinder head (6) and intake manifold (5). Discard gaskets (4).

#### b. Installation

1. Install hose (8) and two clamps (7) on water manifold (3). Do not tighten clamps (7).
2. Install three new gaskets (4) and water manifold (3) on cylinder head (6) and intake manifold (5) with six new lockwashers (2) and screws (1).
3. Tighten two clamps (7) on hose (8).

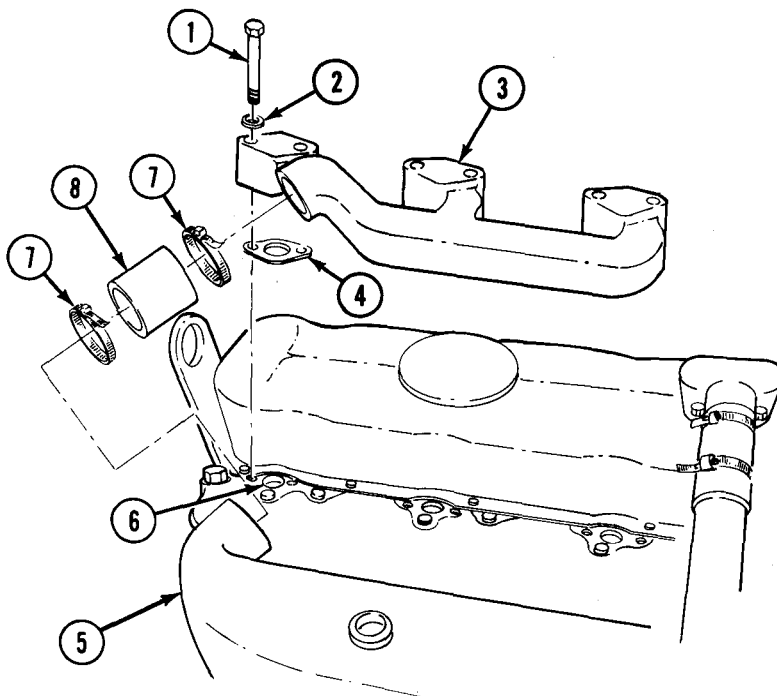

FOLLOW-ON TASK: Install manifold heater (uncovered) (para. 3-31).

### 3-46. THERMOSTAT, HOUSING, AND HOSE REPLACEMENT

This task covers:

- a. Removal
- b. Testing
- c. Installation

#### INITIAL SETUP:

##### APPLICABLE MODELS

All

##### MATERIALS/PARTS

Two lockwashers  
Gasket  
Seal

##### REFERENCES (TM)

TM 9-2320-361-10  
TM 9-2320-361-20P

##### EQUIPMENT CONDITION

- Parking brake set (TM 9-2320-361-10).
- Hood raised and secured (TM 9-2320-361-10).
- Upper radiator hose removed (para. 3-43).

##### GENERAL SAFETY INSTRUCTIONS

Use caution when testing thermostat. Hot water may cause injury to personnel.

#### a. Removal

##### NOTE

Have drainage container ready to catch coolant.

1. Loosen two clamps (4) on hose (5).
2. Remove two screws (3), lockwashers (2), housing (1), and gasket (8) from intake manifold (7) and hose (5). Discard lockwashers (2) and gasket (8).

##### NOTE

Observe position of seal in housing.

3. Remove thermostat (10) and seal (9) from housing (1). Discard seal (9).
4. Remove hose (5) and two clamps (4) from water pump (6).

#### b. Testing

##### WARNING

Use caution when testing thermostat, hot water may cause injury to personnel.

##### NOTE

Do not let thermostat touch container sides.

1. Place thermostat (10) in container of water heated to 185°F (85°C).
2. Observe thermostat (10). If thermostat fails to open, replace thermostat (10).

#### c. Installation

1. Install hose (5) and two clamps (4) on water pump (6). Do not tighten clamps (4).

##### NOTE

New seal must be pressed into same position as old seal.

2. Install new seal (9) on housing (1) by tapping into place.
3. Install thermostat (10) on housing (1).
4. Install new gasket (8) and housing (1) on hose (5) and intake manifold (7) with two new lockwashers (2) and screws (3).
5. Tighten two clamps (4) on hose (5).

**3-46. THERMOSTAT HOUSING AND HOSE REPLACEMENT (Contd)**

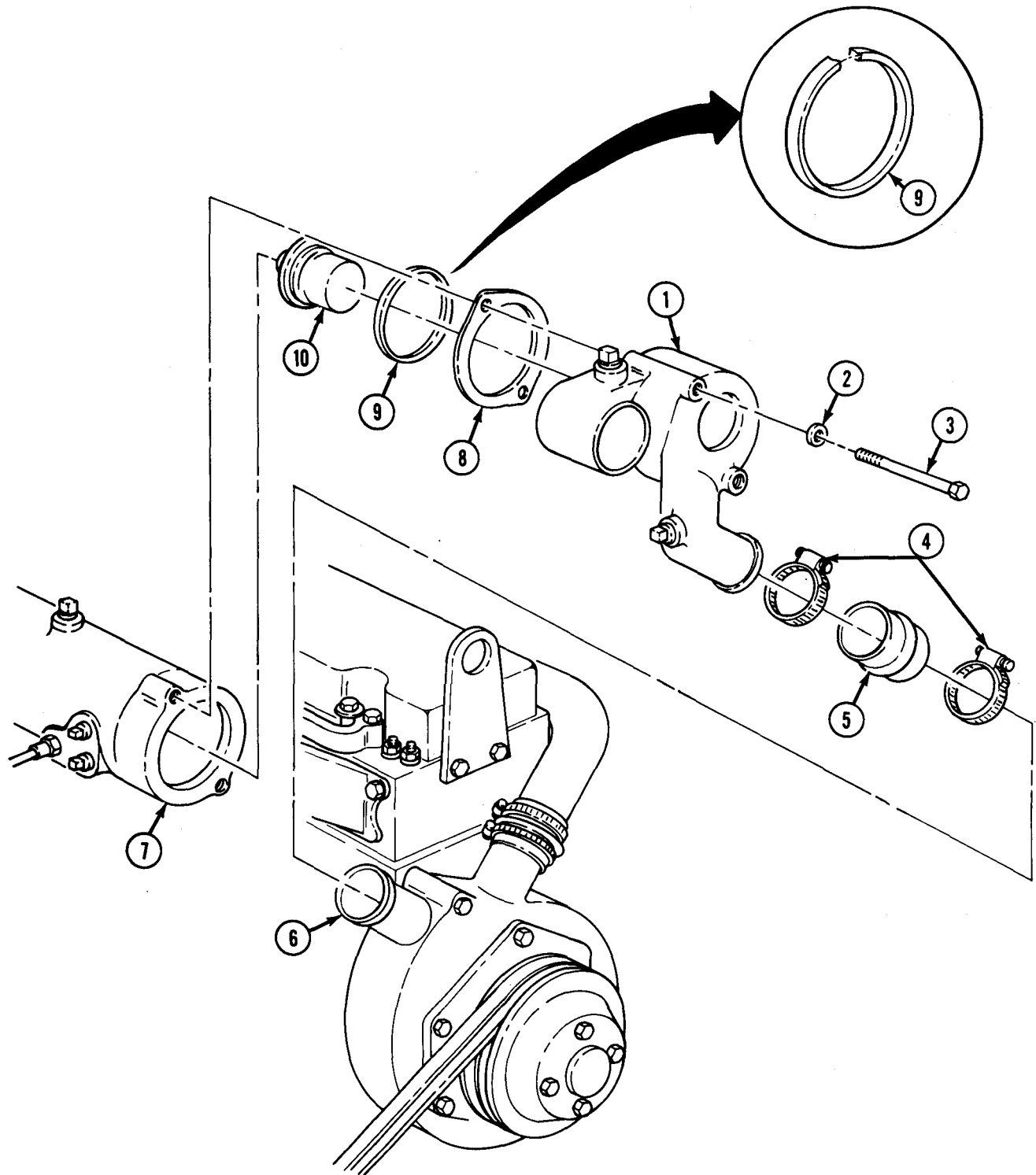

FOLLOW-ON TASK: Install upper radiator hose (para. 3-43).



## 3-47. WATER PUMP HOUSING AND WATER PUMP REPLACEMENT

This task covers:

- a. Water Pump Housing Removal
- b. Water Pump Removal

- c. Water Pump Installation
- d. Water Pump Housing Installation

### INITIAL SETUP:

#### APPLICABLE MODELS

All

#### MATERIALS/PARTS

Ten lockwashers  
Gasket

#### REFERENCES (TM)

TM 9-2320-361-10  
TM 9-2320-361-20P

#### EQUIPMENT CONDITION

- Parking brake set (TM 9-2320-361-10).
- Hood raised and secured (TM 9-2320-361-10).
- Radiator removed (para. 3-42).
- Fan removed (para. 3-40).
- Alternator belts removed (para. 4-2).

### a. Water Pump Housing Removal

1. Remove nut (10), lockwasher (11), washer (12), and adjusting link (13) from water pump housing (6). Discard lockwasher (11).
2. Loosen two clamps (4) on hoses (5).

#### NOTE

Have drainage container available to catch coolant.

3. Loosen clamp (2) and disconnect inlet hose (1) from draincock (14).
4. Remove draincock (14) and adapter (3) from water pump housing (6).
5. Remove three screws (8) and lockwashers (7) from water pump housing (6). Discard lockwashers (7).
6. Remove water pump housing (6) from cylinder block (9) and two hoses (5).

### b. Water Pump Removal

1. Remove six nuts (15) and lockwashers (16) from water pump housing (6). Discard lockwashers (16).
2. Remove water pump drive assembly (17) and gasket (18) from water pump housing (6). Discard gasket (18).

#### NOTE

Perform step 3 if studs are to be replaced.

3. Remove six studs (19) and one stud (20) from water pump housing (6).

### c. Water Pump Installation

#### NOTE

Perform step 1 if studs were removed.

1. Install six studs (19) and one stud (20) on water pump housing (6).
2. Install new gasket (18) and water pump drive assembly (17) on water pump housing (6) with six new lockwashers (16) and nuts (15).

### d. Water Pump Housing Installation

1. Install water pump housing (6) on two hoses (5) and cylinder block (9) with three new lockwashers (7) and screws (8).
2. Tighten two clamps (4) on hoses (5).

**3-47. WATER PUMP HOUSING AND WATER PUMP REPLACEMENT (Contd)**

3. Install adjusting link (13) on water pump housing (6) with washer (12), new lockwasher (11), and nut (10).
4. Install adapter (3) and draincock (14) on water pump housing (6).
5. Install inlet hose (1) on draincock (14). Tighten clamp (2).

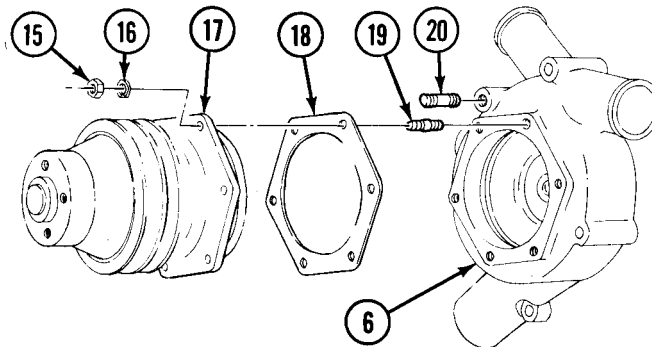
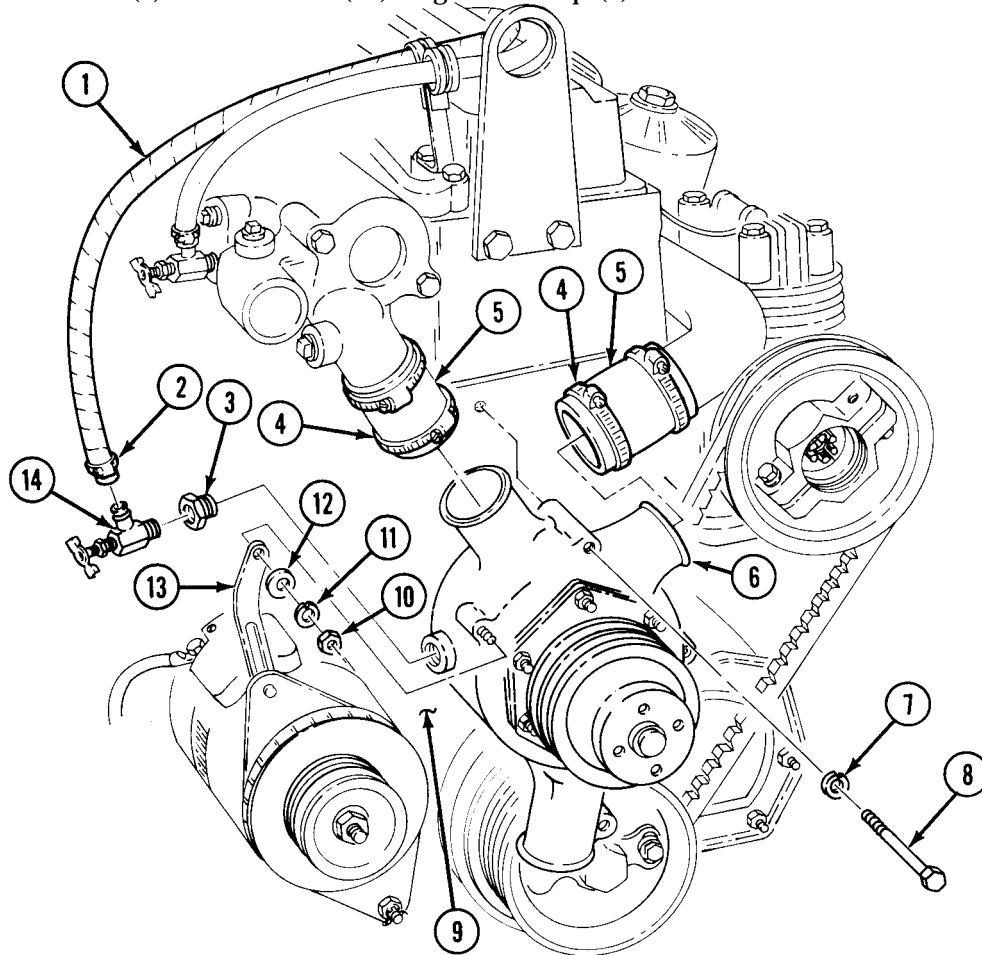

**FOLLOW-ON TASKS:** Ž Alternator belts replaced (para. 4-2).  
 • Install fan (para. 3-40).  
 • Install radiator (para. 3-42).

### 3-48. OIL COOLER TUBE AND HOSES REPLACEMENT

This task covers:

- a. Removal
- b. Installation

**INITIAL SETUP:**

APPLICABLE MODELS

All

REFERENCES (TM)

TM 9-2320-361-10  
 TM 9-2320-361-20P

EQUIPMENT CONDITION

- Parking brake set (TM 9-2320-361-10).
- Hood raised and secured (TM 9-2320-361-10).
- Radiator removed (para. 3-42).

**a. Removal**

1. Loosen four clamps (2) on two hoses (3).
2. Remove oil cooler tube (5), two hoses (3), and four clamps (2) from water pump (1) and engine oil cooler (4).

**b. Installation**

1. Install oil cooler tube (5) and two hoses (3) on water pump (1) and engine oil cooler (4) with four
2. Tighten four clamps (2) on two hoses (3).

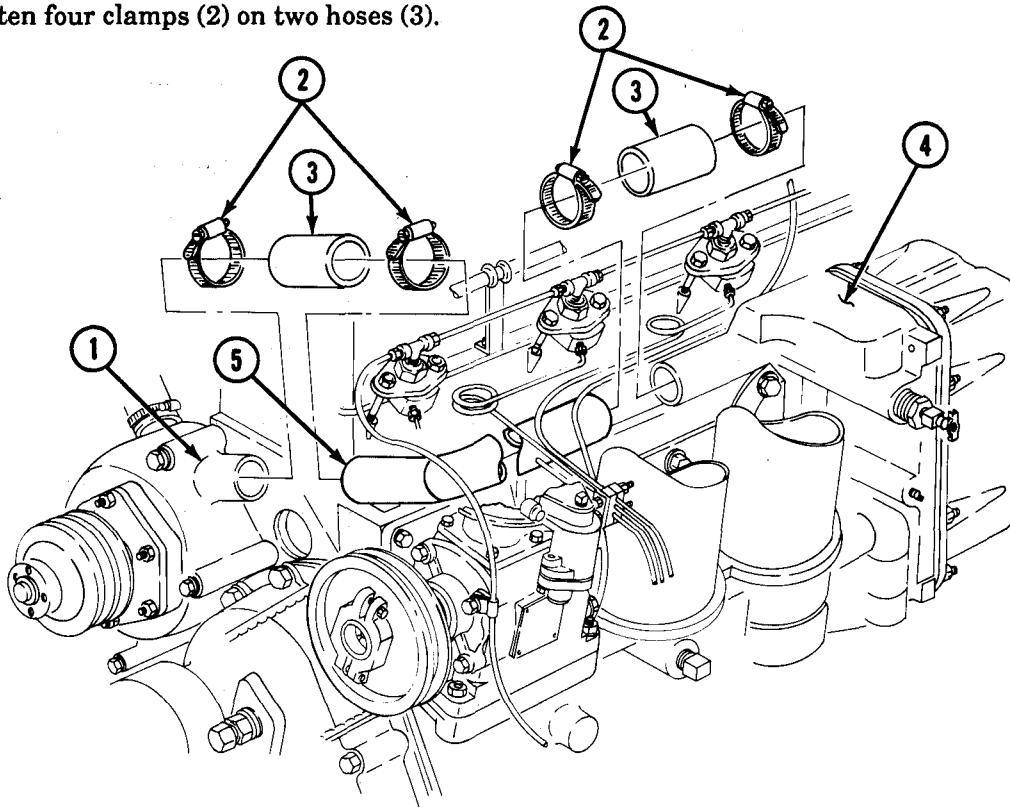

FOLLOW-ON TASK: Install radiator (para. 3-42).

## CHAPTER 4 ELECTRICAL SYSTEM MAINTENANCE

Section I.	Charging System Maintenance (page 4-1)
Section II.	Starting System Maintenance (page 4-10)
Section III.	Instruments, Sending Units, Switches, and Horn Maintenance (page 4-15)
Section IV.	Lighting System Maintenance (page 4-57)
Section V.	Battery and Battery Box Maintenance (page 4-72)
Section VI.	Wiring Harness Maintenance (page 4-79)

### Section I. CHARGING SYSTEM MAINTENANCE

#### 4-1. CHARGING SYSTEM MAINTENANCE INDEX

PARA. NO.	TITLE	PAGE NO.
4-2.	Alternator Belts Maintenance	4-1
4-3.	Alternator (60 Ampere) and Mounting Bracket Replacement	4-4
4-4.	Alternator Pulley Replacement	4-8

#### 4-2. ALTERNATOR BELTS MAINTENANCE

This task covers:

- |   |  |
|---|--|
| <ul style="list-style-type: none"> <li>a. Removal</li> <li>b. Inspection</li> </ul> | <ul style="list-style-type: none"> <li>c. Installation and Adjustment</li> </ul> |
|---|--|

**INITIAL SETUP:**

APPLICABLE MODELS

All

MATERIALS/PARTS

Two cotter pins

REFERENCES (TM)

TM 9-2320-361-10

TM 9-2320-361-20P

EQUIPMENT CONDITION

- Parking brake set (TM 9-2320-361-10).
- Ž Hood raised and secured (TM 9-2320-361-10).
- Battery ground cable disconnected (para. 4-48).

## 4-2. ALTERNATOR BELTS MAINTENANCE (Contd)

### a. Removal

1. Loosen screws (9) and nut (2) on alternator adjusting arm (1).
2. Remove two cotter pins (6) and loosen front and rear locknuts (7). Discard cotter pins (6).
3. Rotate alternator (12) toward engine (11) and remove two alternator belts (4) from alternator pulley (8), water pump pulley (3), and vibration damper (5).

### b. Inspection

Inspect two alternator belts (4) for cracks, fraying, and splits. Replace if cracked, frayed, or split.

### c. Installation and Adjustment

#### NOTE

Alternator belts are a matched set.

1. Install two alternator belts (4) on vibration damper (5), water pump pulley (3), and alternator pulley (8).
2. Position prybar (10) between engine (11) and alternator (12). Pull prybar (10) down until belts (4) appear tight.
3. Place straight edge (13) across alternator pulley (8) and water pump pulley (3) and check for 0.75 in. (1.905 cm) deflection on alternator belts (4).
4. Tighten screw (9) at adjusting arm (1) 15-20 lb-ft (20-27 N.m).
5. Tighten nut (2) at adjusting arm (1) 25-31 lb-ft (34-42 N.m).
6. Tighten two nuts (7) and install two new cotter pins (6). Tighten nuts (7) 33-42 lb-ft (45-57 N.m).

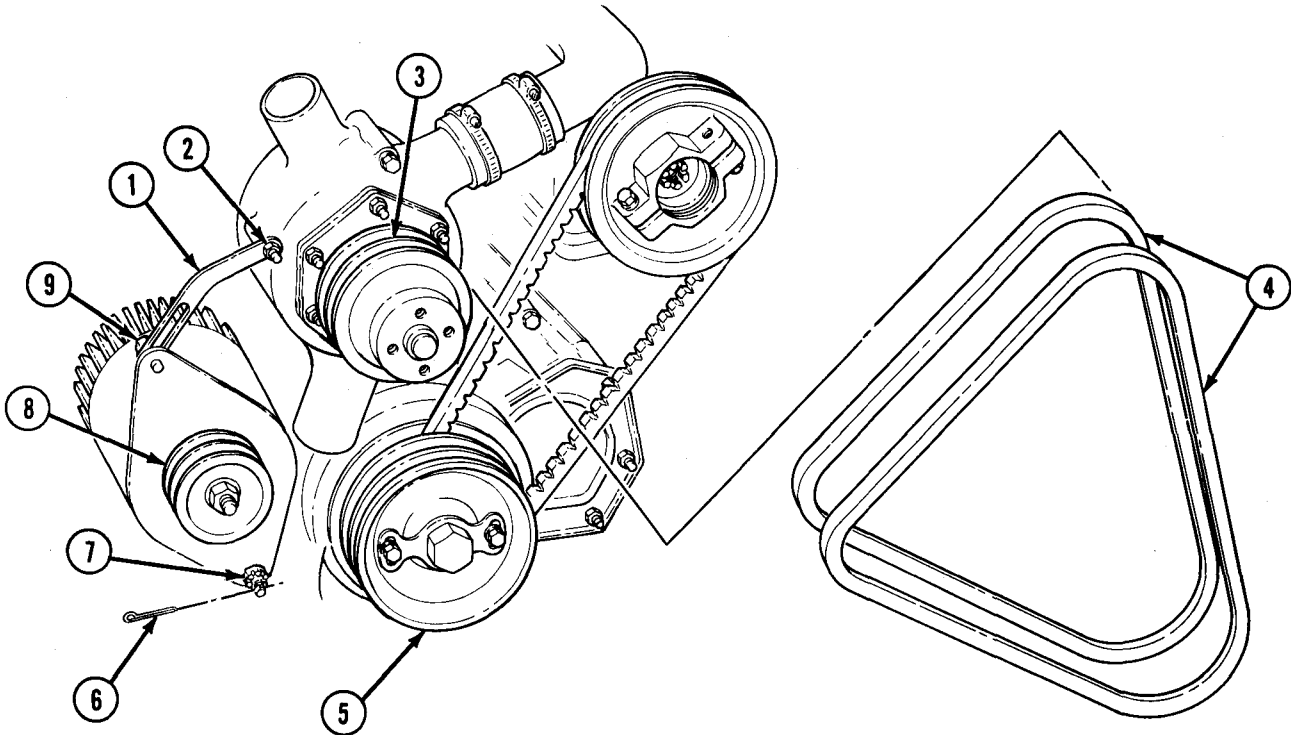

**4-2. ALTERNATOR BELTS MAINTENANCE (Contd)**

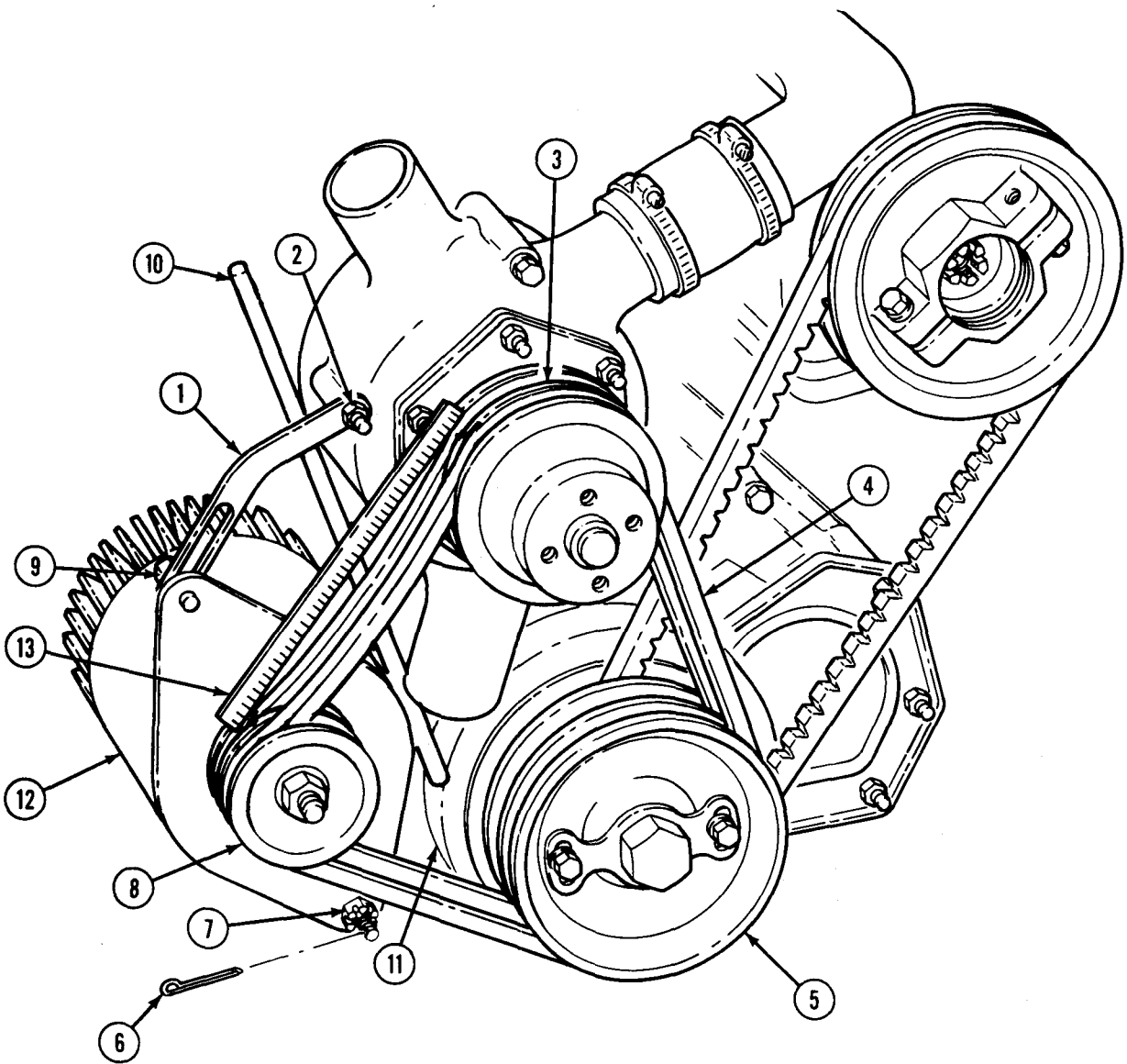

- FOLLOW-ON TASKS:
- Connect battery ground cable (para. 4-48).
  - Start engine (TM 9-2320-361-10) and check if battery-generator indicator is in green area.

**4-3. ALTERNATOR (60 AMPERE) AND MOUNTING BRACKET REPLACEMENT**

This task covers:

- a. Removal
- b. Installation
- c. Adjustment

**INITIAL SETUP:**

APPLICABLE MODELS

All

MATERIALS/PARTS

Two cotter pins  
 Eleven lockwashers  
 Adhesive sealant (Appendix C, Item 5)  
 Sealing compound (Appendix C, Item 23)

PERSONNEL REQUIRED

Two

REFERENCES (TM)

TM 9-2320-361-10  
 TM 9-2320-361-20P

EQUIPMENT CONDITION

- Parking brake set (TM 9-2320-361-10).
- Hood raised and secured (TM 9-2320-361-10).
- Battery ground cable disconnected (para. 4-48).

GENERAL SAFETY INSTRUCTIONS

Alternator must be supported during removal and installation.

**a. Removal**

**CAUTION**

Never operate the alternator with the output terminal (POS) disconnected. Damage to alternator will result.

**NOTE**

Tag wires for installation.

1. Remove two screws (12) and lockwashers (11) from terminal cover (10). Discard lockwashers (11).
2. Pry cover (10) away from waterproofing sealant and remove cover (10).
3. Remove two screws (4), lockwashers (3), wire retaining strap (2), and spacer (1) from alternator (25). Discard lockwashers (3).
4. Remove screw (6), lockwasher (5), and ground wire (7) from alternator (25). Discard lockwasher (5).

**NOTE**

- Alternator has an AC terminal not used on M44A2 series trucks.
- Ž Waterproofing sealant must be removed before removing wire in step 5.

5. Remove nut (9), lockwasher (8), and wire (36) from stud (35). Discard lockwasher (8).
6. Disconnect wire (33) from wire (34).
7. Remove screw (18), lockwasher (19), and washer (17) from alternator adjusting arm (16) and alternator (25). Discard lockwasher (19).
8. Remove nut (15), lockwasher (14), and alternator adjusting arm (16) from engine stud (13). Discard lockwasher (14).
9. Remove two alternator belts (20) from alternator pulley (21).

**4-3. ALTERNATOR (60 AMPERE) AND MOUNTING BRACKET REPLACEMENT (Contd)**

**WARNING**

Alternator must be supported during removal. Failure to support alternator may cause injury to personnel or damage to equipment.

10. Remove two cotter pins (22), two nuts (23), shims (31), four washers (24) and (26), two screws (27), and alternator (25). Discard two cotter pins (22).

**NOTE**

Perform step 11 only if alternator mounting bracket is damaged.

11. Remove three screws (28), lockwashers (29) and alternator mounting bracket (30) from engine (32). Discard lockwashers (29).
12. Remove alternator pulley (21) (para. 4-4).

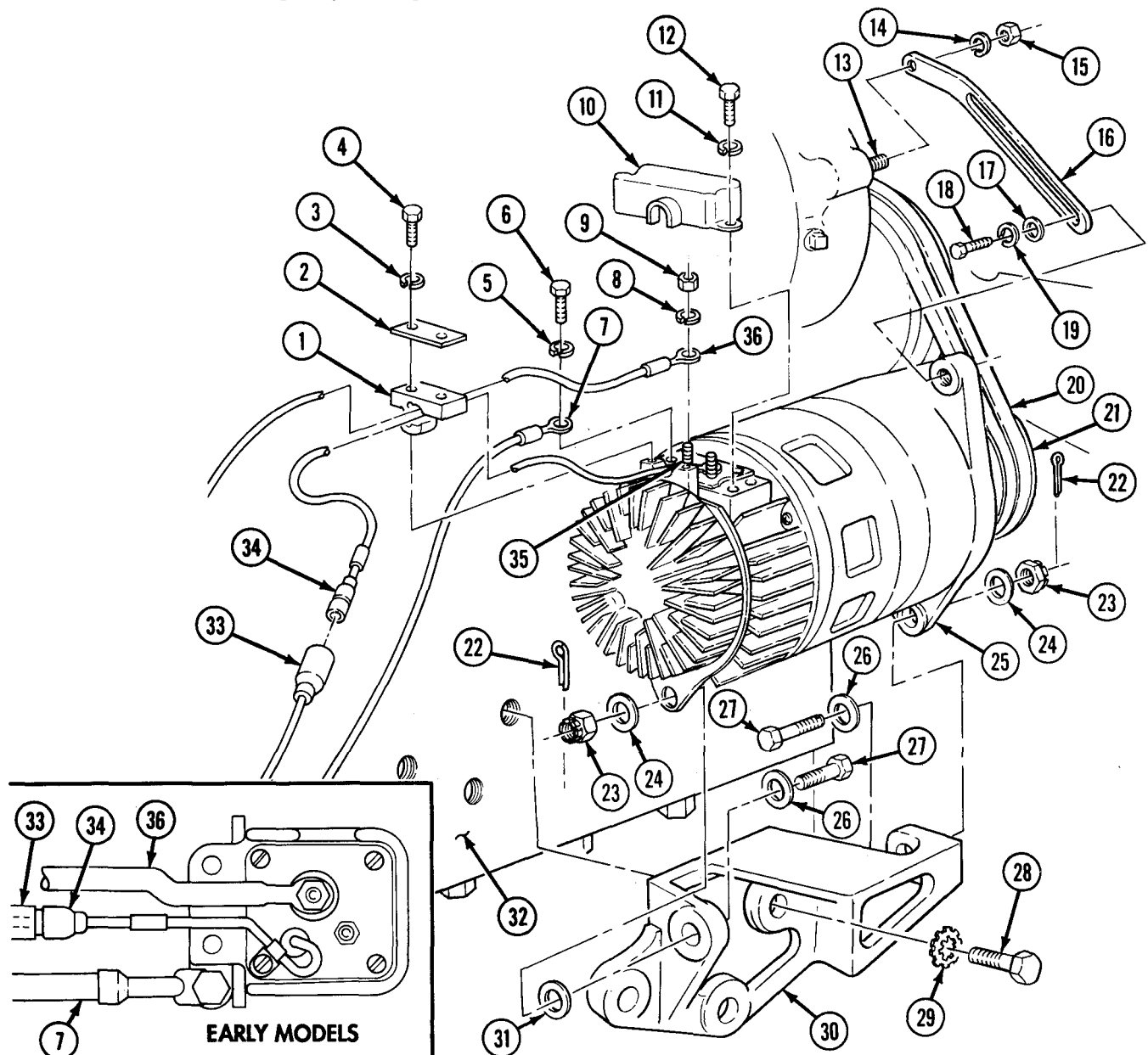



## 4-3. ALTERNATOR (60 AMPERE) AND MOUNTING BRACKET REPLACEMENT (Contd)

### b. Installation

1. Install alternator pulley (21) (para. 4-4).

#### NOTE

Perform step 2 only if mounting bracket has been removed.

2. Install alternator mounting bracket (30) on engine (32) with three new lockwashers (29) and screws (28). Tighten screws (28) 60-71 lb-ft (81-96 N•m).
3. Install alternator adjusting arm (16) to engine stud (13) with new lockwasher (14) and nut (15). Finger tighten only.

#### WARNING

Alternator must be supported during installation. Failure to support alternator may cause injury to personnel or damage to equipment.

4. Install alternator (25) on mounting bracket (30) with two screws (27), four washers (26) and (24), shims (31) as required, and two nuts (23). Finger tighten only.
5. Install alternator adjusting arm (16) on alternator (25) with washer (17), new lockwasher (19), and screw (18). Finger tighten only.
6. Install and adjust alternator belts (20) (para. 4-2). Tighten two screws (27) 33-42 lb-ft (45-57 N•m).
7. Connect wire (33) to wire (34) and install two new cotter pins (22) through locknuts (23).

#### NOTE

- Ensure terminals are clean before connections are made.
- Ž Alternator has an AC terminal not used on M44A2 series trucks.

8. Install wire (36) on stud (35) with new lockwasher (8) and nut (9). Tighten nut (9) 45-55 lb-in. (5-6 NŽm).
9. Install ground wire (7) to alternator (25) with new lockwasher (5) and screw (6). Tighten screw (6) 82-102 lb-in. (9-12 NŽm).
10. Install spacer (1) and wire retaining strap (2) over wires (7) and (36) on alternator (25) with two new lockwashers (3) and screws (4). Tighten screws (4) 30-35 lb-in. (1-2 NŽm).

### c. Adjustment

1. Connect battery ground cable (para. 4-48) and start engine (TM 9-2320-361-10).
2. Set engine speed to 1200 rpm (TM 9-2320-361-10).
3. Turn on headlights (TM 9-2320-361-10) to place load on alternator.
4. Using multimeter, check alternator output voltage. Connect black lead to ground cable (7) and touch red lead to wire (33). Output voltage should be  $28.0 \pm 0.2$  VDC. If adjustment is required, continue with next step. If no adjustment is required, go to step 7.
5. Remove pipe plug (37) from alternator (25).
6. Turn adjusting screw counterclockwise to increase or clockwise to decrease voltage.
7. Apply sealing compound to pipe plug (37) threads. Using hex head driver, install pipe plug (37) and tighten 24-36 lb-in. (3-4 NŽm).
8. Turn off headlights (TM 9-2320-361-10).
9. Stop engine (TM 9-2320-361-10).
10. Seal wires (36), (7), and (34) and connectors and stud (35) completely with adhesive sealant.
11. Install terminal cover (10) on alternator (25) with two new lockwashers (11) and screws (12).

**4-3. ALTERNATOR (60 AMPERE) AND MOUNTING BRACKET REPLACEMENT (Contd)**

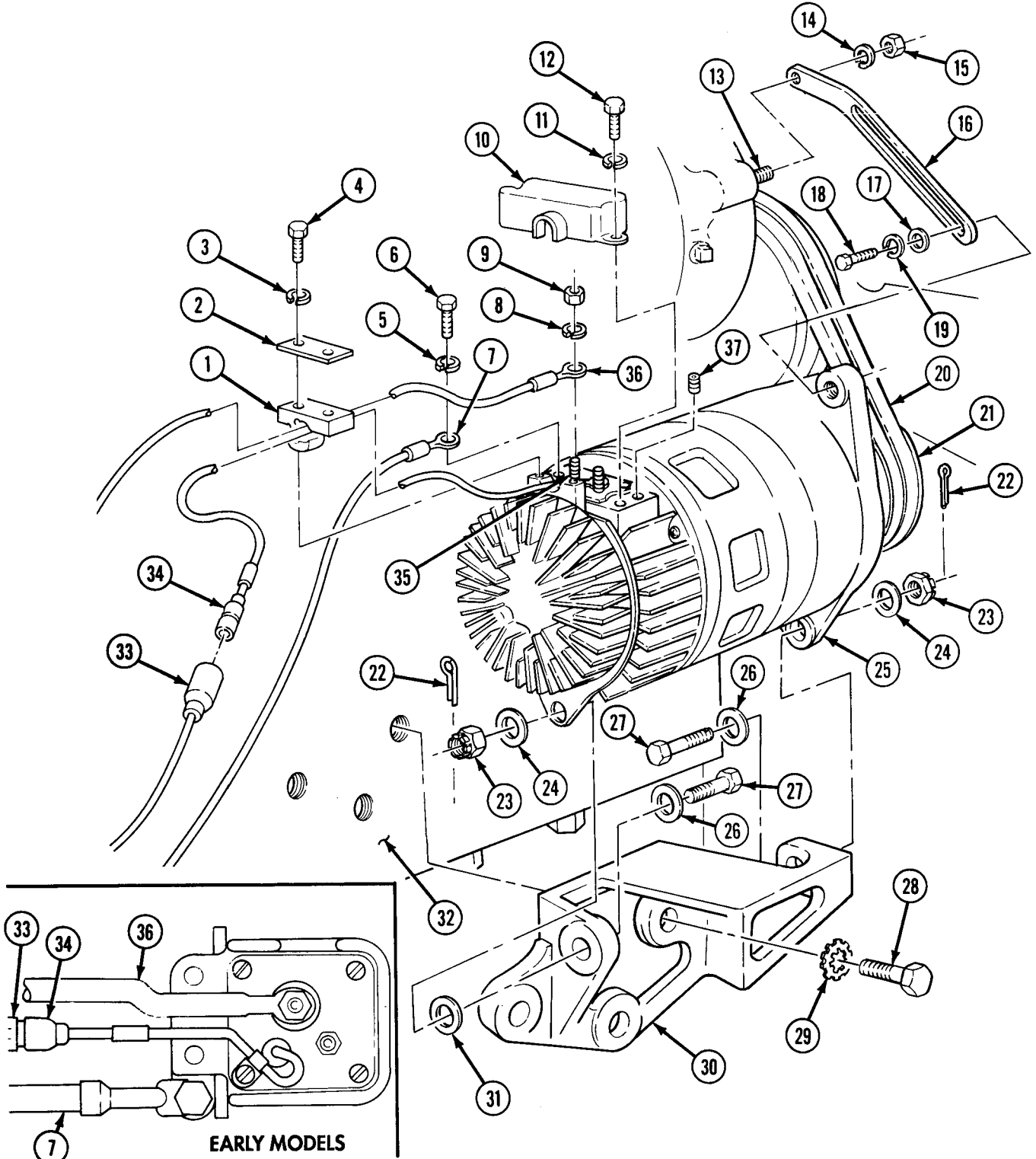

FOLLOW-ON TASKS: • Connect battery ground cable (para. 4-48).  
 • Start engine (TM 9-2320-361-10) and check if battery-generator indicator is in green area.

## 4-4. ALTERNATOR PULLEY REPLACEMENT

This task covers:

a. Removal

b. Installation

### INITIAL SETUP:

APPLICABLE MODELS

All

TOOLS

Puller kit PE12

MATERIALS/PARTS

Woodruff key

Locknut

REFERENCES (TM)

TM 9-2320-361-20P

EQUIPMENT CONDITION

Alternator removed (para. 4-3).

### a. Removal

1. Clamp alternator pulley (2) in a soft-jawed vise (3).
2. Remove locknut (5) and washer (4) from alternator shaft (7). Discard locknut (5).
3. Remove alternator (1) and pulley (2) from soft-jawed vise (3).
4. Using the puller, remove alternator pulley (2) and woodruff key (6) from alternator shaft (7). Discard woodruff key (6).

### b. Installation

1. Position new woodruff key (6) in alternator shaft (7) with flat side up.
2. Aline pulley keyway (8) with woodruff key (6) in alternator shaft (7) and tap pulley (2) onto alternator shaft (7).
3. Install washer (4) and new locknut (5) on alternator shaft (7). Tighten locknut (5) finger tight.
4. Clamp alternator pulley (2) in soft-jawed vise (3).
5. Tighten locknut (5) 90-100 lb-ft (122-135 NŹm).
6. Remove alternator pulley (2) from vise (3).

**4-4. ALTERNATOR PULLEY REPLACEMENT (Contd)**

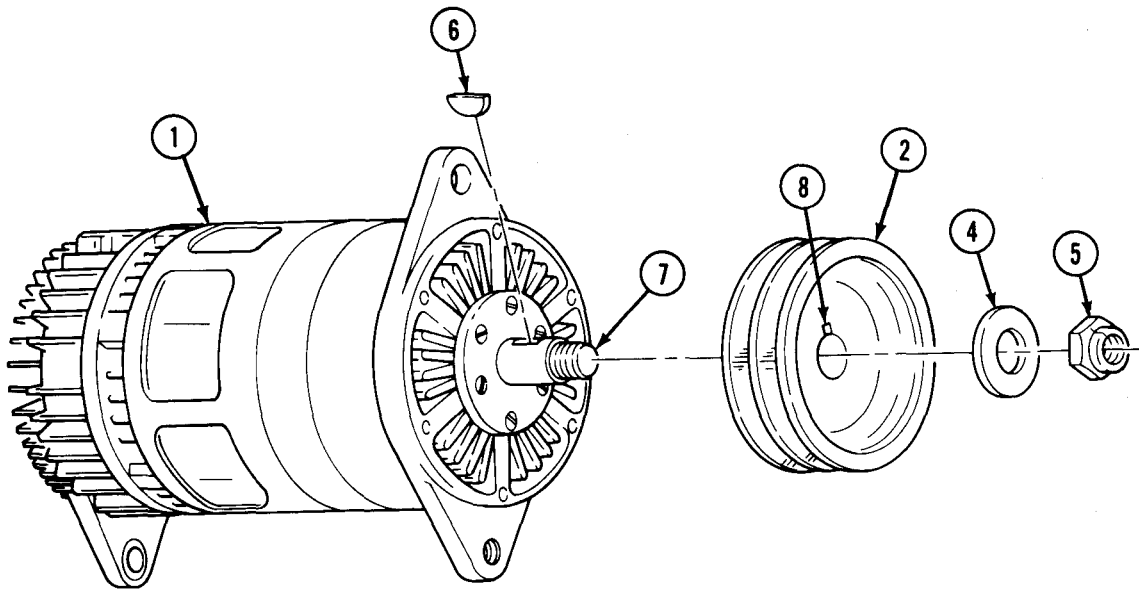
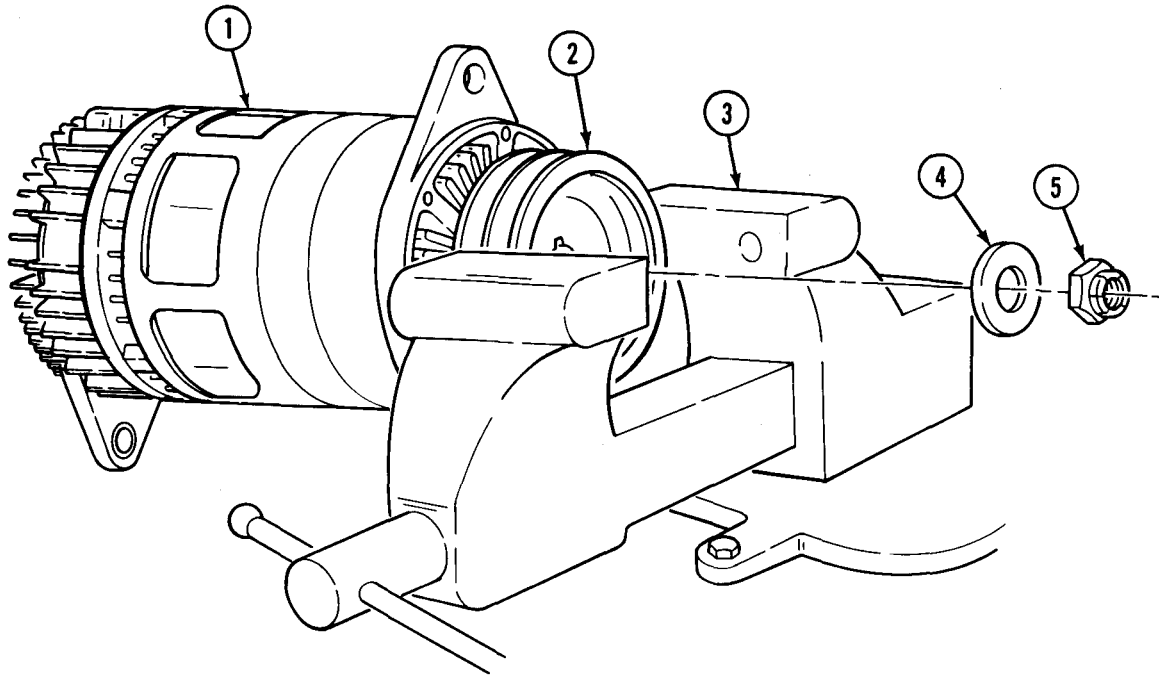

FOLLOW-ON TASK: Install alternator (para. 4-3).

Section II. STARTING SYSTEM MAINTENANCE

**4-5. STARTING SYSTEM MAINTENANCE INDEX**

PARA. NO.	TITLE	PAGE NO.
4-6.	Magnetic Starter Relay and Mounting Bracket Replacement	4-10
4-7.	Starter Motor Replacement	4-12
4-8.	Starter Switch Replacement	4-14

**4-6. MAGNETIC STARTER RELAY AND MOUNTING BRACKET REPLACEMENT**

This task covers:

a. Removal

b. Installation

**INITIAL SETUP:**

APPLICABLE MODELS

All

MATERIALS/PARTS

Two locknuts  
Six lockwashers

REFERENCES (TM)

TM 9-2320-361-10  
TM 9-2320-361-20P

EQUIPMENT CONDITION

- Z Parking brake set (TM 9-2320-361-10).
- Hood raised and secured (TM 9-2320-361-10).
- Battery ground cable disconnected (para. 4-48).
- Air cleaner assembly removed (para. 3-15).

**a. Removal**

**NOTE**

Tag leads for installation.

1. Remove nut (1), washer (2), and cable (3) from magnetic starter relay (19).
2. Remove nut (9), washer (8), and cables (7) and (6) from magnetic starter relay (19).
3. Remove nut (16), washer (17), and cable (18) from magnetic starter relay (19).
4. Remove two locknuts (4), lockwashers (5), screws (15), and magnetic starter relay (19) from mounting bracket (10). Discard two locknuts (4) and lockwashers (5).
5. Remove two screws (14), lockwashers (13) and (12), and mounting bracket (10) from engine block (11). Discard lockwashers (13) and (12).

**b. Installation**

1. Install mounting bracket (10) on engine block (11) with two screws (14) and new lockwashers (13) and (12).
2. Install magnetic starter relay (19) on mounting bracket (10) with two screws (15), new lockwashers (5), and locknuts (4).
3. Install cable (3) on relay (19) with washer (2) and nut (1).
4. Install cables (6) and (7) on relay (19) with washer (8) and nut (9).
5. Install cable (18) on relay (19) with washer (17) and nut (16).

#### 4-6. MAGNETIC STARTER RELAY AND MOUNTING BRACKET REPLACEMENT (Contd)

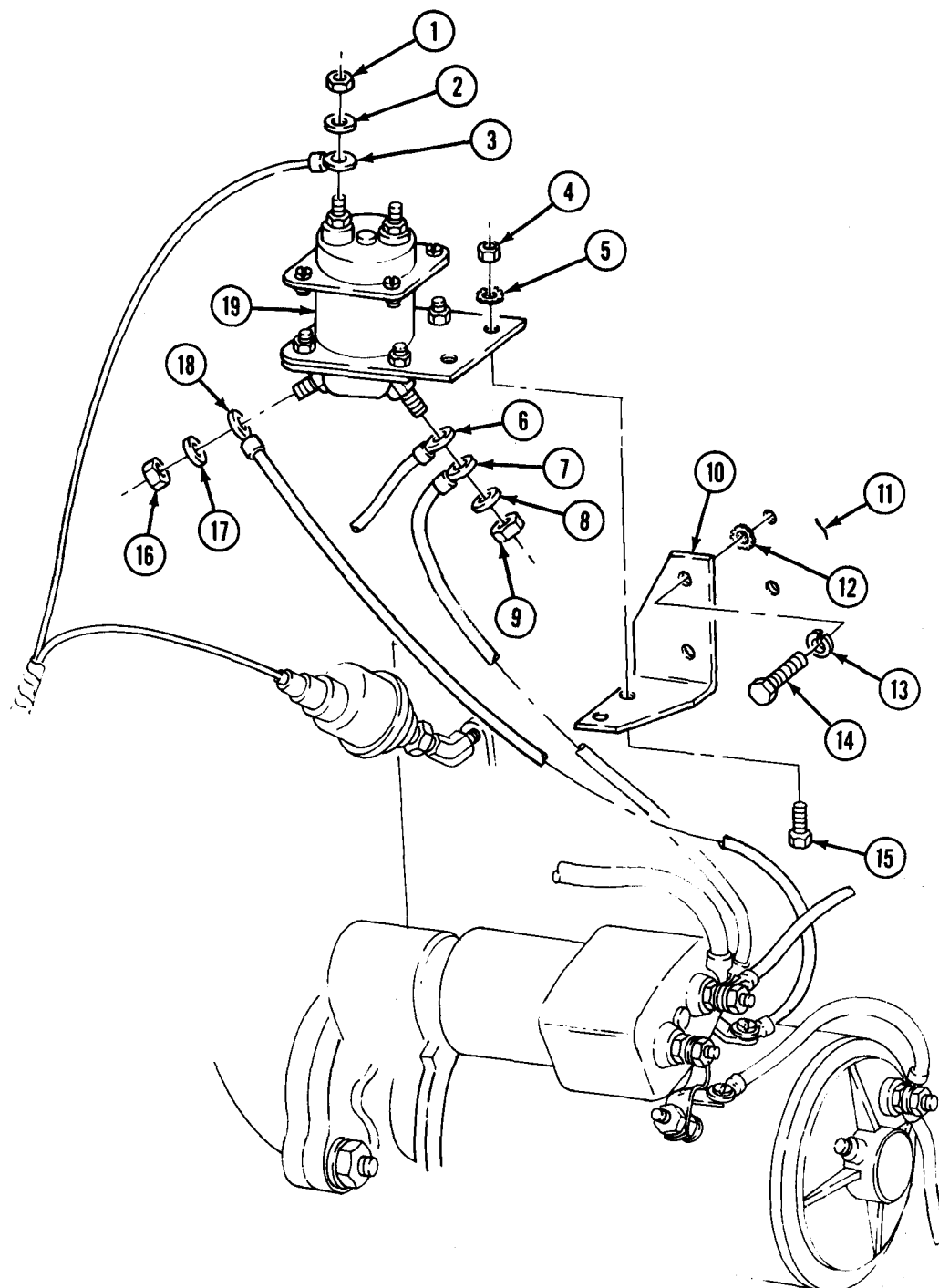

- FOLLOW-ON TASKS:
- Install air cleaner assembly (para. 3-15).
  - Connect battery ground cable (para. 4-48).
  - Start engine (TM 9-2320-361-10).

## 4-7. STARTER MOTOR REPLACEMENT

This task covers:

a. Removal

b. Installation

### INITIAL SETUP:

APPLICABLE MODELS

All

MATERIALS/PARTS

Two gaskets  
Four lockwashers

PERSONNEL REQUIRED

Two

REFERENCES (TM)

TM 9-2320-361-10  
TM 9-2320-361-20P

EQUIPMENT CONDITION

Z Parking brake set (TM 9-2320-361-10).  
• Battery ground cable disconnected (para. 4-48).  
• Air cleaner assembly removed (para. 3-15).

### a. Removal

**NOTE**

Tag leads for installation.

1. Remove screw (6), clip (7), and wire (8) from starter solenoid terminal (9).

**NOTE**

Remove two wires from solenoid stud on M756A2 model.

2. Remove nut (5), wire (3), and cable (4) from solenoid stud (2).
3. Remove nut (10), lockwasher (11), and ground cable (12) from starter motor stud (13). Discard lockwasher (11).

**NOTE**

Assistant will help with step 4.

4. Remove three nuts (15), lockwashers (14), and starter motor (1) from studs (19). Discard lockwashers (14).
5. Remove gasket (16), spacer (17), and gasket (18) from studs (19). Discard gaskets (16) and (18).

### b. Installation

1. Position new gasket (18), spacer (17), and new gasket (16) on three studs (19). Make sure flat side of gasket (16) faces starter motor (1).

**NOTE**

Assistant will help with step 2.

2. Install starter (1) on studs (19) with three new lockwashers (14) and nuts (15). Tighten nuts (15) 70-80 lb-ft (95-108 NŹm).
3. Install ground cable (12) on starter solenoid terminal (13) with new lockwasher (11) and nut (10).

**NOTE**

Install two wires on solenoid stud for M756A2 model.

4. Install cable (4) and wire (3) on solenoid stud (2) with nut (5).
5. Install wire (8) on starter solenoid terminal (9) with clip (7) and screw (6).

**4-7. STARTER MOTOR REPLACEMENT (Contd)**

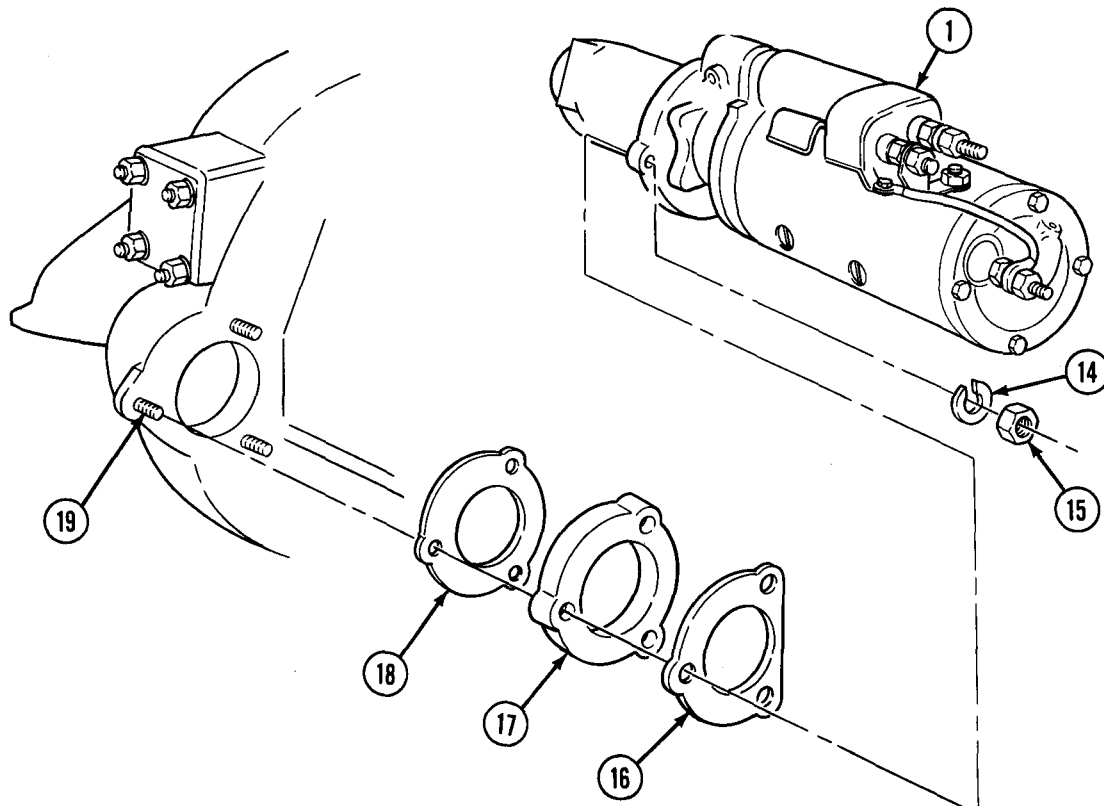
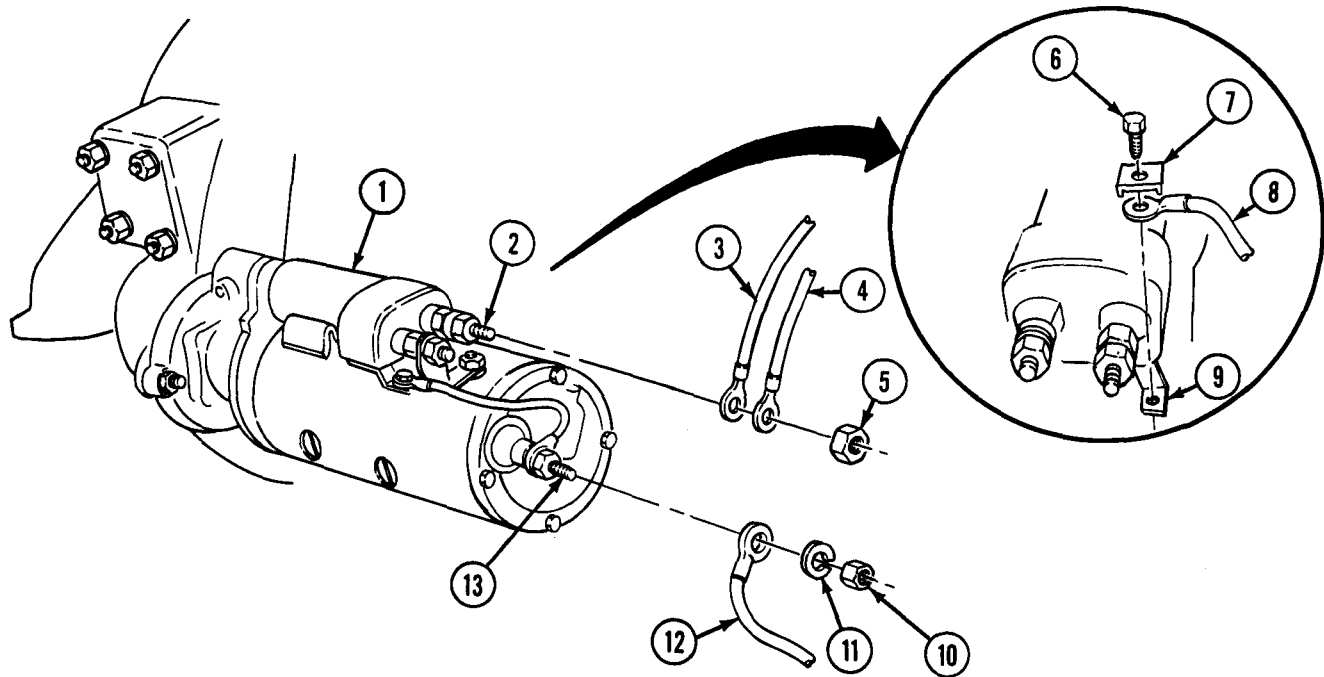

- FOLLOW-ON TASKS:**
- Install air cleaner (para. 3-15).
  - Connect battery ground cable (para. 4-48).
  - Start engine (TM 9-2320-361-10) to check starter motor.



## 4-8. STARTER SWITCH REPLACEMENT

This task covers:

a. Removal

b. Installation

### INITIAL SETUP:

APPLICABLE MODELS

All

MATERIALS/PARTS

Lockwasher

REFERENCES (TM)

TM 9-2320-361-10

TM 9-2320-361-20P

EQUIPMENT CONDITION

- Parking brake set (TM 9-2320-361-10).
- Battery ground cable disconnected (para. 4-48).

### NOTE

Starter switch may be located to the right of the steering column on older models.

#### a. Removal

1. Remove nut (3) from engine starter switch (5).
2. Remove lockwasher (2), plate (1), and starter switch (5) from instrument panel (7). Discard lockwasher (2).
3. Disconnect plug (6) from starter switch (5).
4. Remove adjusting nut (4) from starter switch (5).

#### b. Installation

1. Install nut (4) on starter switch (5).
2. Connect plug (6) to starter switch (5).
3. Install starter switch (5) and plate (1) on instrument panel (7) with new lockwasher (2) and nut (3).

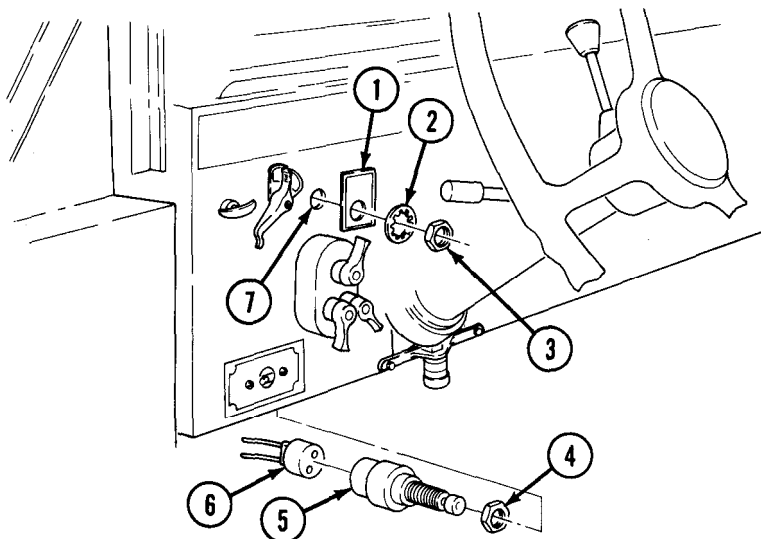

- FOLLOW-ON TASKS:
- Connect battery ground cable (para. 4-48).
  - Start engine (TM 9-2320-361-10).

### Section III. INSTRUMENTS, SENDING UNITS, SWITCHES, AND HORN MAINTENANCE

#### 4-9. INSTRUMENTS, SENDING UNITS, SWITCHES, AND HORN MAINTENANCE INDEX

PARA. NO.	TITLE	PAGE NO.
4-10.	Instrument Cluster Replacement	4-16
4-11.	Air Pressure Gage Replacement	4-20
4-12.	Oil Pressure Gage, Battery and Generator Gage, Fuel Gage, and Engine Temperature Gage Replacement	4-22
4-13.	Speedometer and Tachometer Replacement	4-24
4-14.	Tachometer Drive shaft and Drive Core Maintenance	4-26
4-15.	Tachometer Adapter Replacement	4-28
4-16.	Speedometer Drive shaft and Adapter Replacement	4-30
4-17.	Headlight High Beam Indicator and Lamp Replacement	4-32
4-18.	Light Switch Replacement	4-33
4-19.	Turn Signal Control and Indicator Lamp Replacement	4-34
4-20.	Turn Signal Flasher Replacement	4-35
4-21.	Accessory Switch Replacement	4-36
4-22.	Manifold Heater Switch Replacement	4-37
4-23.	Oil Pressure Sending Unit Replacement	4-38
4-24.	Engine Temperature Sending Unit Replacement	4-39
4-25.	Low Air Pressure Switch Replacement	4-40
4-26.	Fuel Level Sending Unit Replacement	4-41
4-27.	Low Air Buzzer Replacement	4-42
4-28.	Headlight Dimmer Switch Replacement	4-44
4-29.	Stoplight Switch Replacement	4-45
4-30.	Horn Button Replacement	4-46
4-31.	Air Horn, Solenoid, and Bracket Replacement	4-48
4-32.	Stoplight Air Pressure Switch Replacement (M275A2)	4-50
4-33.	Circuit Breaker Replacement	4-51
4-34.	Hot Water Personnel Heater Control Switch Replacement	4-52
4-35.	Hot Water Personnel Heater Blower Motor Resistor Replacement	4-53
4-36.	Front-Wheel Drive Lock-In Switch Indicator and Air Pressure Switch Replacement	4-54
4-37.	Fuel Pressure Switch Replacement	4-56

## 4-10. INSTRUMENT CLUSTER REPLACEMENT

This task covers:

- |                |                 |
|----------------|-----------------|
| a. Removal     | c. Assembly     |
| b. Disassembly | d. Installation |

INITIAL SETUP:

APPLICABLE MODELS

All

MATERIALS/PARTS

Antiseize tape (Appendix C, Item 27)

REFERENCES (TM)

TM 9-2320-361-10

TM 9-2320-361-20P

EQUIPMENT CONDITION

- Parking brake set (TM 9-2320-361-10).
- Battery ground cable disconnected (para. 4-48).
- Air reservoirs drained (TM 9-2320-361-10).

GENERAL SAFETY INSTRUCTIONS

Do not disconnect air lines before draining air reservoirs.

### a. Removal

1. Turn four lockstuds (1) ¼ turn to left and pull instrument cluster (2) away from instrument panel (3).

**NOTE**

- Tag each wire, air tube, and drive shaft for installation.
- Location of gages on instrument cluster may vary for M44A2 series trucks, Install gages in their original locations.

2. Disconnect tachometer drive shaft (19) from tachometer (6).
3. Disconnect speedometer drive shaft (12) from speedometer (7).

**WARNING**

Do not disconnect air lines before draining air reservoir. Small parts under pressure may shoot out with high velocity, causing injury to personnel.

4. Disconnect air line (26) from air pressure gage (27).
5. Disconnect wire plug (16) from wire connector (17).
6. Disconnect wire plugs (5) and (25) from engine temperature gage (4).
7. Disconnect wire plugs (10) and (11) from oil pressure gage (9).
8. Disconnect wire plugs (20) and (18) from fuel gage (21).
9. Disconnect wire connector (14) from high beam indicator (15).
10. Disconnect wire connectors (13) and (23) from two indicator lamps (8).
11. Disconnect wire plug (22) from battery and generator gage (24).
12. Remove instrument cluster (2) from instrument panel (3).

4-10. INSTRUMENT CLUSTER REPLACEMENT (Contd)

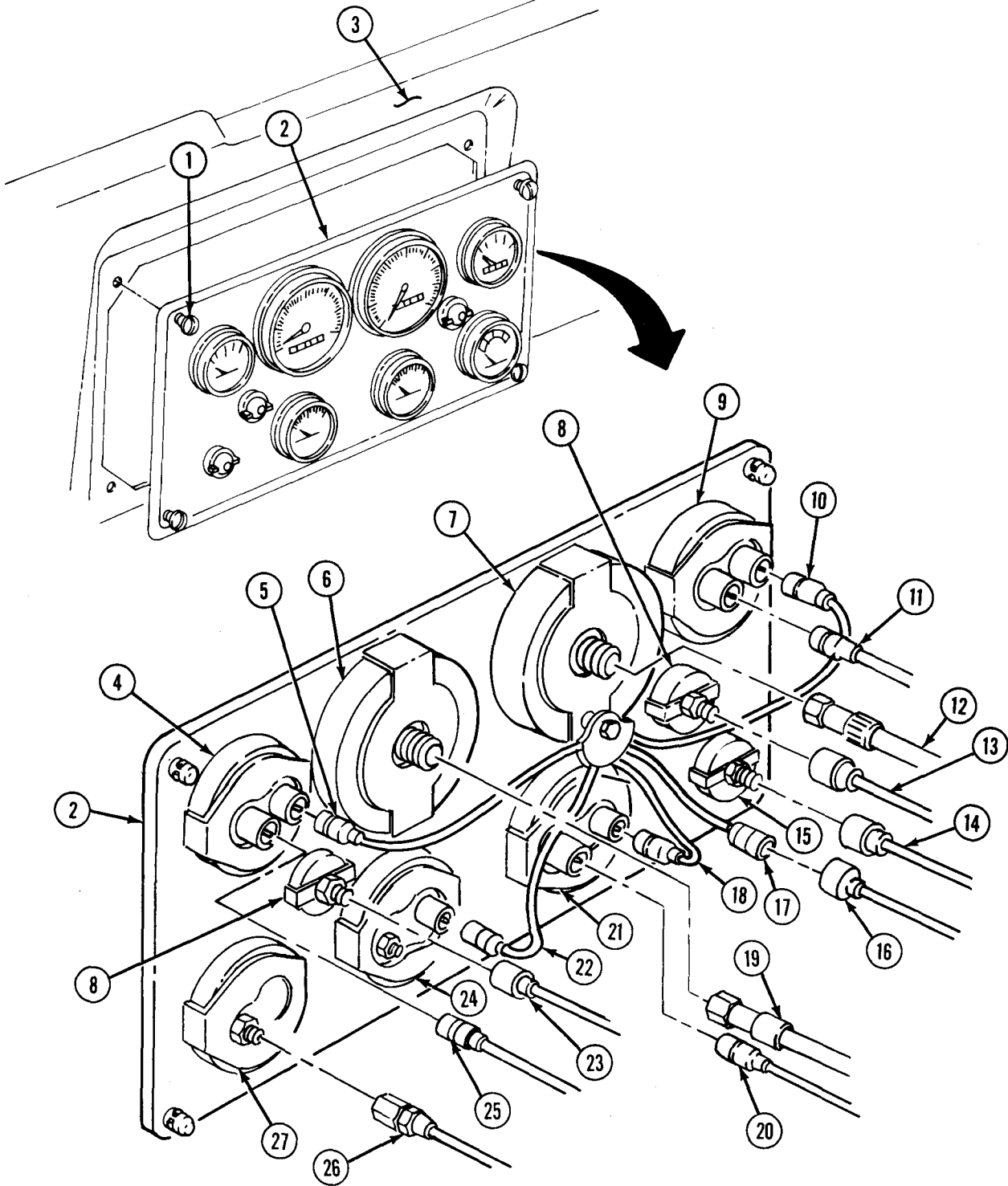

## 4-10. INSTRUMENT CLUSTER REPLACEMENT (Contd)

### b. Disassembly

1. Remove two indicator panel lamps (8) (para. 4-17).
2. Remove high beam indicator (15) (para. 4-17).
3. Remove tachometer (6) (para. 4-13).
4. Remove speedometer (7) (para. 4-13).
5. Remove oil pressure gage (9), engine temperature gage (4), battery and generator gage (24), and fuel gage (21) (para. 4-12).
6. Remove air pressure gage (27) (para. 4-11).

### c. Assembly

1. Install air pressure gage (27) (para. 4-11).
2. Install fuel gage (21), battery and generator gage (24), engine temperature gage (4), and oil pressure gage (9) (para. 4-12).
3. Install speedometer (7) (para. 4-13).
4. Install tachometer (6) (para. 4-13).
5. Install high beam indicator (15) (para. 4-17).
6. Install two indicator panel lamps (8) (para. 4-17).

### d. Installation

1. Connect wire plug (22) to battery and generator gage (24).
2. Connect wire connectors (13) and (23) to both panel lamps (8).
3. Connect wire connector (14) to high beam indicator (15).
4. Connect wire plugs (20) and (18) to fuel gage (21).
5. Connect wire plugs (10) and (11) to oil pressure gage (9).
6. Connect wire plugs (5) and (25) to engine temperature gage (4).
7. Connect wire plug (16) to wire connector (17).
8. Wrap threads of air pressure gage (27) with antiseize tape and connect air line (26).
9. Connect speedometer drive shaft (12) to speedometer (7).
10. Connect tachometer drive shaft (19) to tachometer (6).
11. Position instrument cluster (2) to instrument panel (3) and install by turning four lockstuds (1) 1/4 turn to right.

**4-10. INSTRUMENT CLUSTER REPLACEMENT (Contd)**

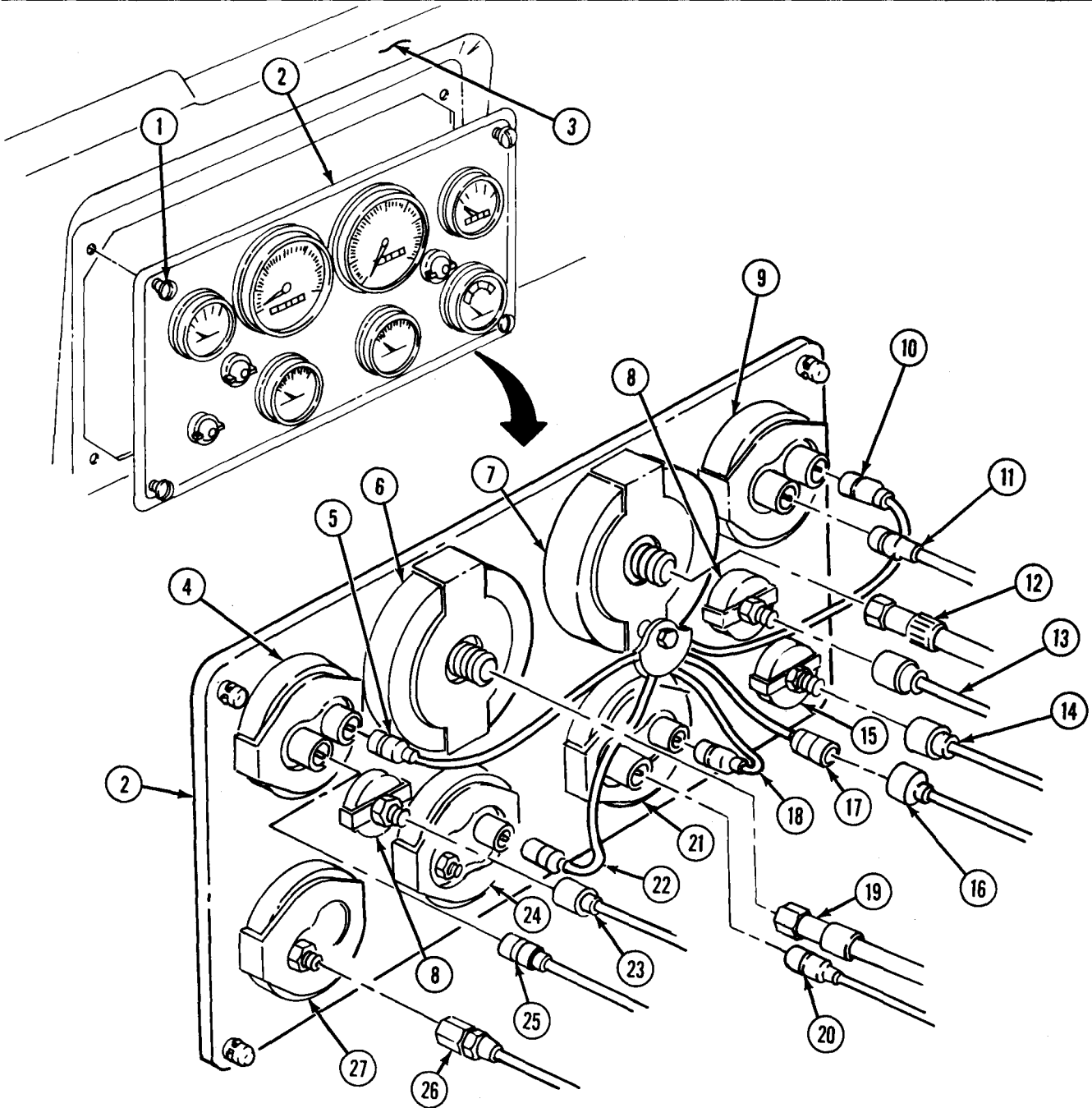

- FOLLOW-ON TASKS:  $\checkmark$  Connect battery ground cable (para. 4-48).
- Start engine (TM 9-2320-361-10) and check if gages work properly and allow air pressure to build up to normal operating range.
  - Check for air leaks at air pressure gage.

## 4-11. AIR PRESSURE GAGE REPLACEMENT

**This task covers:**

a. Removal

b. Installation

**INITIAL SETUP:**

APPLICABLE MODELS

All

MATERIALS/PARTS

Two lockwashers  
Antiseize tape (Appendix C, Item 27)

REFERENCES [TM]

TM 9-2320-361-10  
TM 9-2320-361-20P

EQUIPMENT CONDITION

- Parking brake set (TM 9-2320-361-10).
- Air reservoirs drained (TM 9-2320-361-10).
- Battery ground cable disconnected (para. 4-48).

GENERAL SAFETY INSTRUCTIONS

Do not disconnect air lines before draining air reservoirs.

### a. Removal

1. Turn four lockstuds (8) ¼ turn to left and pull instrument cluster (6) away from instrument panel (5).

#### WARNING

Do not disconnect air lines before draining air reservoirs. Small parts under pressure may shoot out with high velocity, causing injury to personnel.

#### NOTE

Location of gages on instrument cluster may vary for M44A2 series trucks. Install gages in their original locations.

2. Disconnect air line (1) from air pressure gage (7).
3. Remove two nuts (2), lockwashers (3), and gage mounting bracket (4) from air pressure gage (7). Discard lockwashers (3).
4. Remove air pressure gage (7) from front of instrument cluster (6).

### b. Installation

1. Position air pressure gage (7) through front of instrument cluster (6).
2. Position gage mounting bracket (4) on air pressure gage (7) and install with two new lockwashers (3) and nuts (2).

#### NOTE

Clean male pipe threads and wrap with antiseize tape before installation.

3. Connect air line (1) to air pressure gage (7).
4. Position instrument cluster (6) on instrument panel (5) and lock in place by turning four lockstuds (8) 1/4 turn to right.

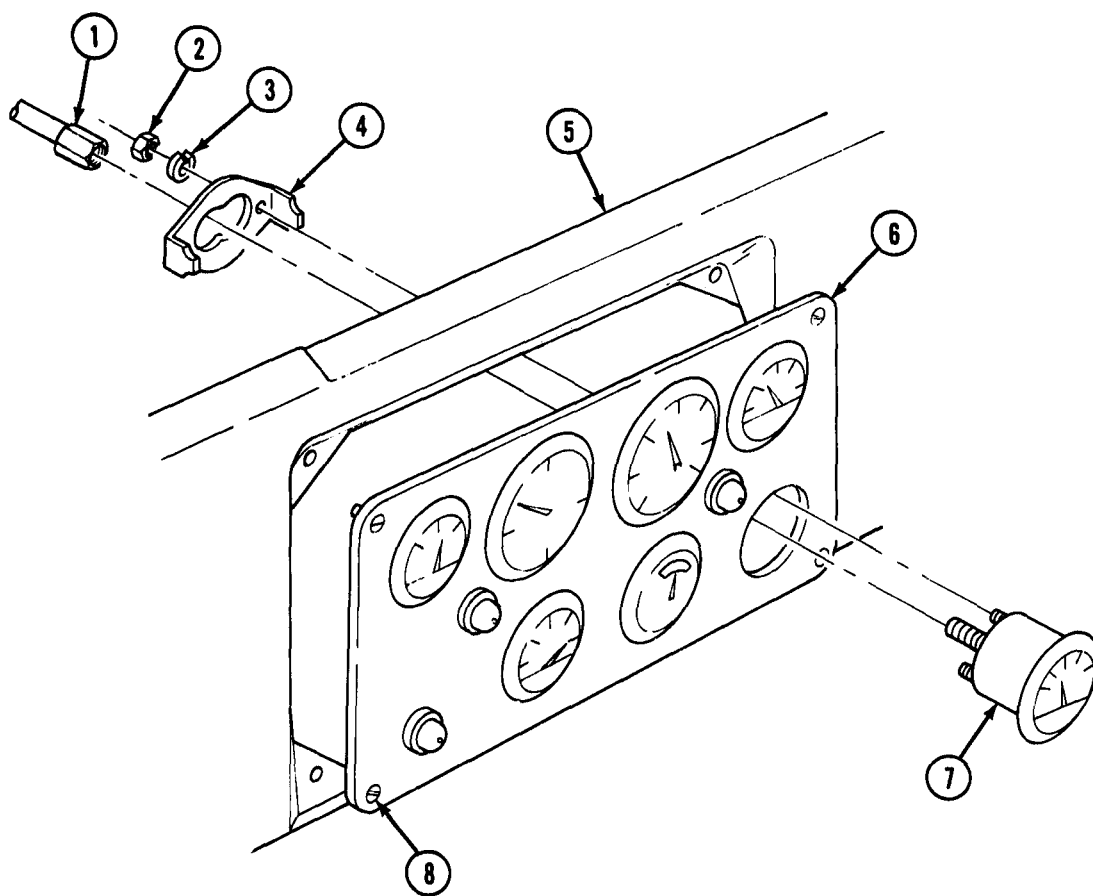
**4-11. AIR PRESSURE GAGE REPLACEMENT (Contd)**

- FOLLOW-ON TASKS:**
- Connect battery ground cable (para. 4-48).
  - Start engine (TM 9-2320-361-10), and allow air pressure to build up to normal operating range.
  - Check for air leaks at air pressure gage.



**4-12. OIL PRESSURE GAGE, BATTERY AND GENERATOR GAGE, FUEL GAGE, AND ENGINE TEMPERATURE GAGE REPLACEMENT**

**This task covers:**

a. Removal

b. Installation

**INITIAL SETUP:**

APPLICABLE MODELS

All

MATERIALS/PARTS

Two lockwashers

REFERENCES (TM)

TM 9-2320-361-10

TM 9-2320-361-20P

EQUIPMENT CONDITION

- Parking brake set (TM 9-2320-361-10).
- Disconnect battery ground cable (para. 4-48).

**CAUTION**

The 60 psi and 120 psi gages and sending units are not interchangeable. Do not interchange the 60 psi gage or sending unit with a 120 psi gage or sending unit.

**NOTE**

Engine temperature, oil pressure, battery and generator, and fuel gages are removed and installed the same. This procedure covers the engine temperature gage.

**a. Removal**

1. Turn four lockstuds (5) ¼ turn to left and pull instrument cluster (7) away from instrument panel (8).

**NOTE**

Tag wires for installation.

2. Disconnect wires (1) and (9) from engine temperature gage (6).
3. Remove two nuts (2), lockwashers (3), and bracket (4) from temperature gage (6). Discard lockwashers (3).
4. Remove engine temperature gage (6) from instrument cluster (7).

**b. Installation**

1. Position engine temperature gage (6) through front of instrument cluster (7).
2. Install bracket (4) on temperature gage (6) with two new lockwashers (3) and nuts (2).
3. Connect wires (1) and (9) to engine temperature gage (6).
4. Position instrument cluster (7) to instrument panel (8) and install by turning four lockstuds (5) ¼ turn to right.

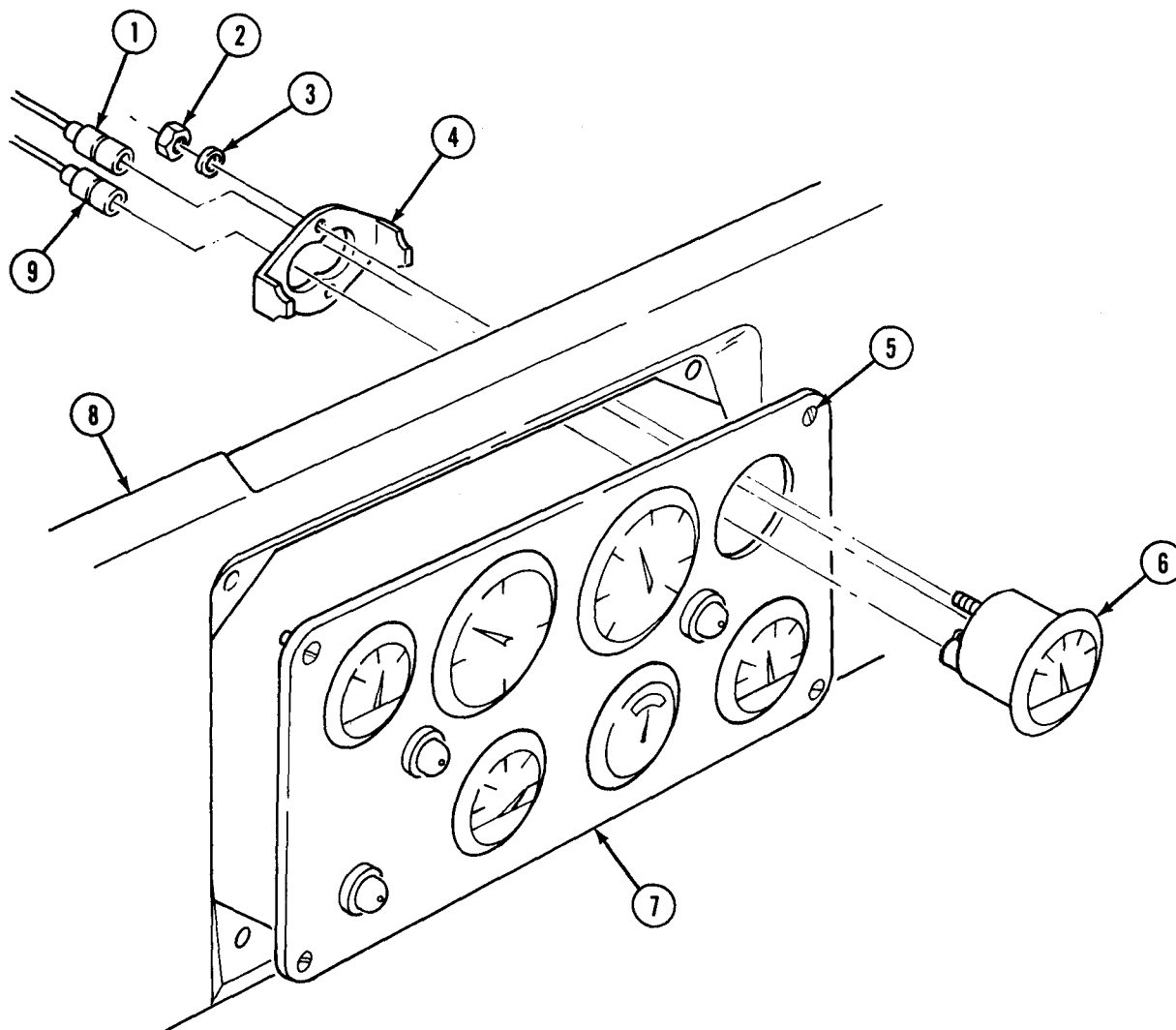
**4-12. OIL PRESSURE GAGE, BATTERY AND GENERATOR GAGE, FUEL GAGE, AND ENGINE TEMPERATURE GAGE REPLACEMENT (Contd)**

- FOLLOW-ON TASKS:
- Connect battery ground cable (para. 4-48).
  - Start engine (TM 9-2320-361-10) and check gages for proper operation.

## 4-13. SPEEDOMETER AND TACHOMETER REPLACEMENT

This task covers:

a. Removal

b. Installation

### INITIAL SETUP:

#### APPLICABLE MODELS

All

#### MATERIALS/PARTS

Two lockwashers

#### REFERENCES (TM)

TM 9-2320-361-10

TM 9-2320-361-20P

#### EQUIPMENT CONDITION

- Parking brake set (TM 9-2320-361-10).
- Battery ground cable disconnected (para. 4-48).

### NOTE

Speedometer and tachometer are removed and installed the same way with exception of instrument cluster cable and extension stud which are on speedometer only. This procedure covers the speedometer.

#### a. Removal

1. Turn four lockstuds (9) 1/4 turn to left and pull instrument cluster (7) away from instrument panel (8).

### NOTE

Tag speedometer drive shaft for installation.

2. Loosen shaft nut (2) and disconnect speedometer drive shaft (1) from speedometer (6).
3. Remove two nuts (3), washer (12), instrument cluster cable assembly (11), extension stud (10), two lockwashers (4), and mounting bracket (5) from speedometer (6). Discard two lockwashers (4).
4. Remove speedometer (6) from instrument cluster (7).

#### b. Installation

1. Position speedometer (6) through front of instrument cluster (7).
2. Position mounting bracket (5) on speedometer (6) and install with two new lockwashers (4), extension stud (10), and nut (3).
3. Install cable assembly (11) with washer (12) and nut (3).
4. Install speedometer drive shaft (1) on speedometer (6) with shaft nut (2).
5. Position instrument cluster (7) on instrument panel (8) and lock in place by turning four lockstuds (9) 1/4 turn to right.

**4-13. SPEEDOMETER AND TACHOMETER REPLACEMENT (Contd)**

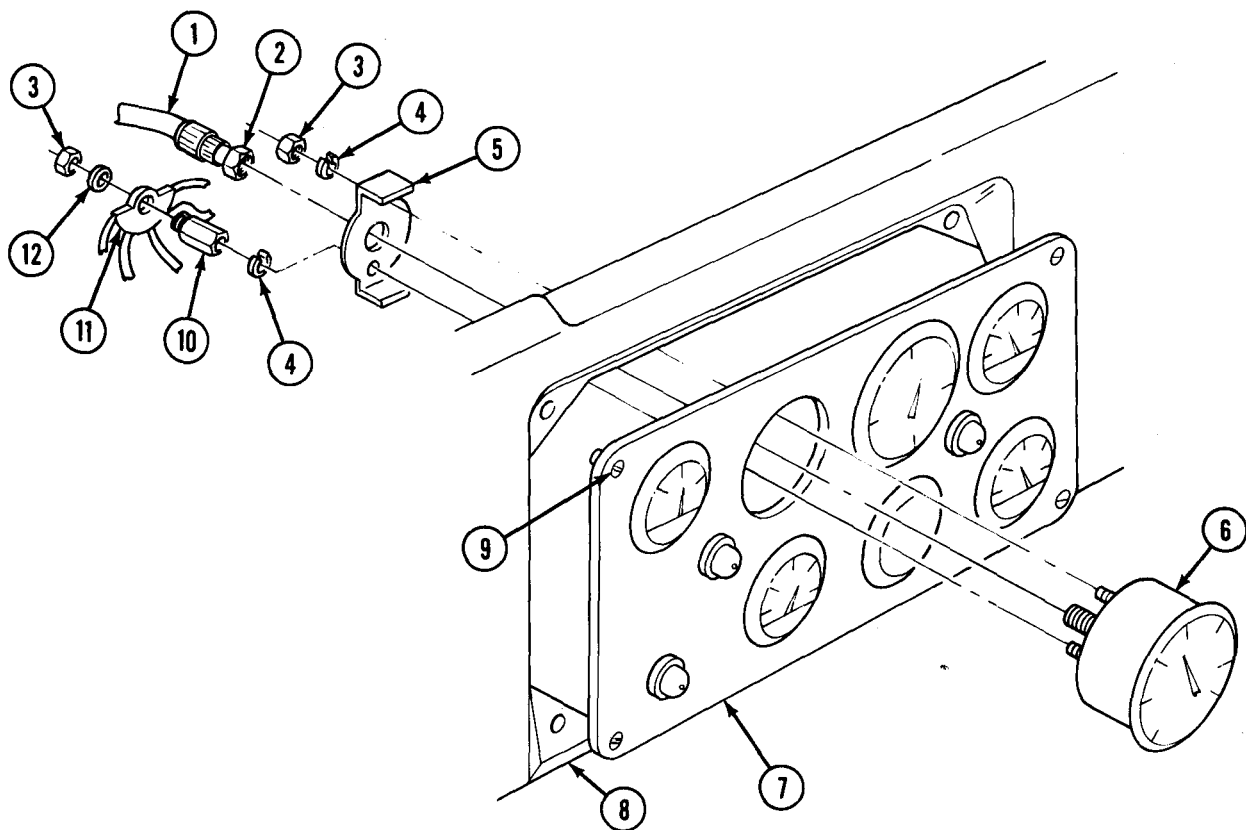

FOLLOW-ON TASKS: •Connect battery ground cable (para. 4-48).  
 •Start engine (TM 9-2320-361-10) and road test to check speedometer and tachometer for proper operation.

## 4-14. TACHOMETER DRIVE SHAFT AND DRIVE CORE MAINTENANCE

**This task covers:**

- |   |   |
|---|---|
| <ul style="list-style-type: none"> <li>a. Removal</li> <li>b. Inspection</li> </ul> | <ul style="list-style-type: none"> <li>c. Installation</li> </ul> |
|---|---|

**INITIAL SETUP:**

APPLICABLE MODELS

All

MATERIALS/PARTS

Three locknuts  
Lockwasher

REFERENCES (TM)

TM 9-2320-361-10  
TM 9-2320-361-20P

EQUIPMENT CONDITION

- Parking brake set (TM 9-2320-361-10).
- Hood raised and secured (TM 9-2320-361-10).
- Battery ground cable disconnected (para. 4-48).

### a. Removal

1. Turn four lockstuds (4) 1/4 turn left and pull instrument cluster (3) away from instrument panel (5).
2. Disconnect tachometer drive shaft (1) from tachometer (2).
3. Disconnect tachometer drive shaft (1) from tachometer drive unit (20).
4. Remove two locknuts (8), screws (15), four clamps (9), tachometer drive shaft (1), and wiring harness (7) from two brackets (17). Discard locknuts (8).
5. Remove locknut (23), screw (21), clamp (22), and tachometer drive shaft (1) from bracket (19). Discard locknut (23).
6. Remove two screws (10), washers (11), and brackets (17) from rocker arm cover (16).
7. Remove nut (25), lockwasher (24), and bracket (19) from air compressor stud (18). Discard lockwasher (24).
8. Remove grommet (12) and tachometer drive shaft (1) from firewall (13).
9. Remove two clamps (9) and clamp (22) from tachometer drive shaft (1).

Inspect drive shaft drive core (14) and grommet (12). Replace if defective.

### c. Installation

1. Install two clamps (9) and clamp (22) on tachometer drive shaft (1).
2. Install tachometer drive shaft (1) and grommet (12) in firewall (13).
3. Install two brackets (17) on rocker arm cover (16) with two washers (11) and screws (10).
4. Install bracket (19) on air compressor stud (18) with new lockwasher (22) and nut (25).
5. Connect tachometer drive shaft (1) to tachometer drive unit (20).
6. Connect tachometer drive shaft (1) to tachometer (2).
7. Install tachometer drive shaft (1), clamp (22), screw (21), and new locknut (23) on bracket (19).
8. Install tachometer drive shaft (1) and wiring harness (7) on two brackets (17) with four clamps (9), two screws (15), and new locknuts (8).
9. Position instrument cluster (3) on instrument panel (5) and lock in place by turning four lockstuds (4) 1/4 turn to right.

**4-14. TACHOMETER DRIVESHAFT AND DRIVE CORE MAINTENANCE (Contd)**

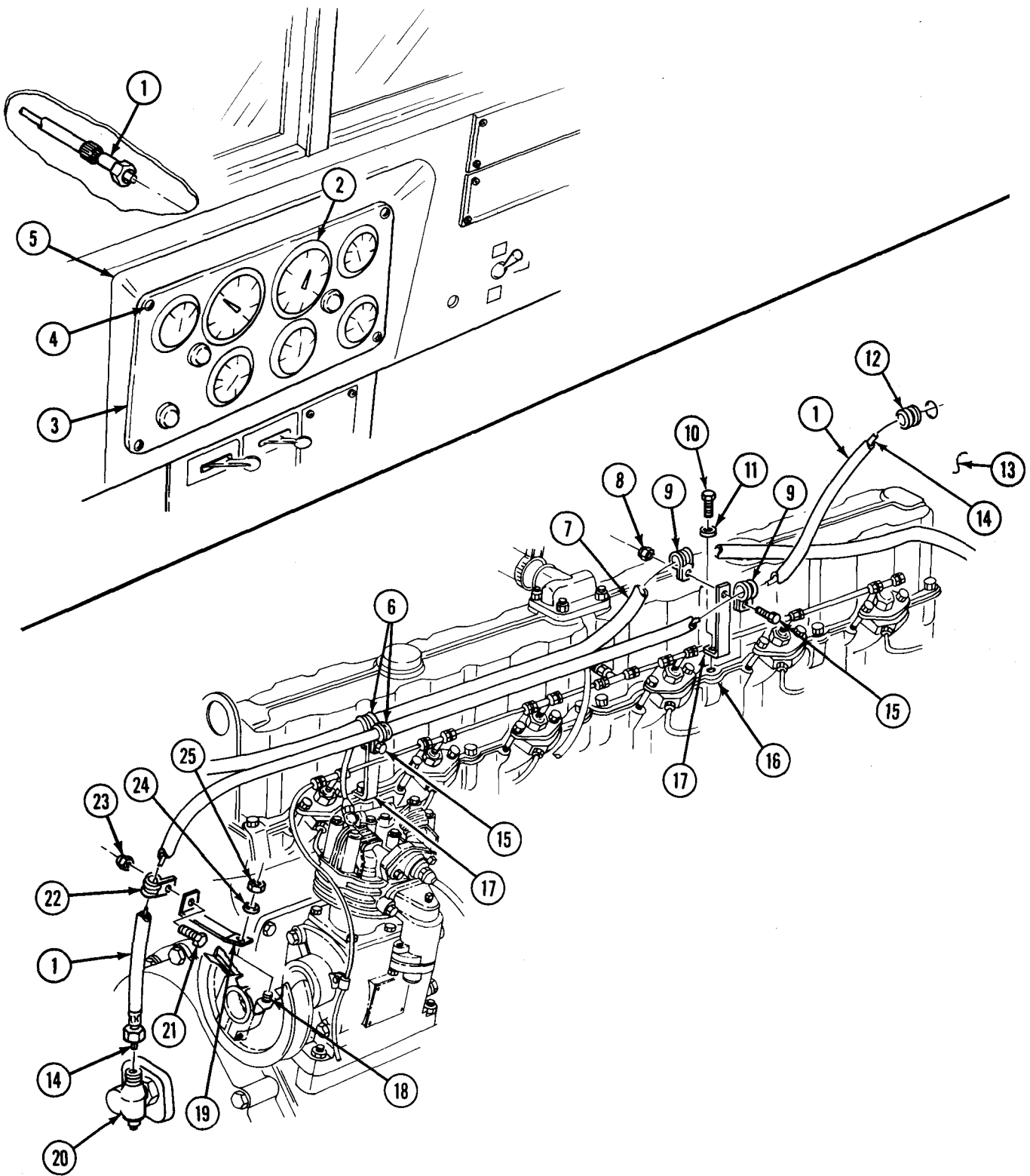

FOLLOW-ON TASK: Connect battery ground cable (para. 4-48).

## 4-15. TACHOMETER ADAPTER REPLACEMENT

This task covers:

a. Removal

b. Installation

INITIAL SETUP:

APPLICABLE MODELS

All

MATERIALS/PARTS

Gasket

REFERENCES (TM)

TM 9-2320-361-10

TM 9-2320-361-20P

EQUIPMENT CONDITION

Z Parking brake set (TM 9-2320-361-10).

•Radiator removed (para. 3-42).

### a. Removal

1. Disconnect tachometer drive shaft (1) from tachometer adapter (5).
2. Remove tachometer adapter (5) from adapter (4).
3. Remove adapter (4) and gasket (3) from timing cover (2). Discard gasket (3).

### b. Installation

1. Install new gasket (3) and adapter (4) on timing cover (2).
2. Install tachometer adapter (5) on adapter (4).
3. Connect tachometer drive shaft (1) on tachometer adapter (5).

**4-15. TACHOMETER ADAPTER REPLACEMENT (Contd)**

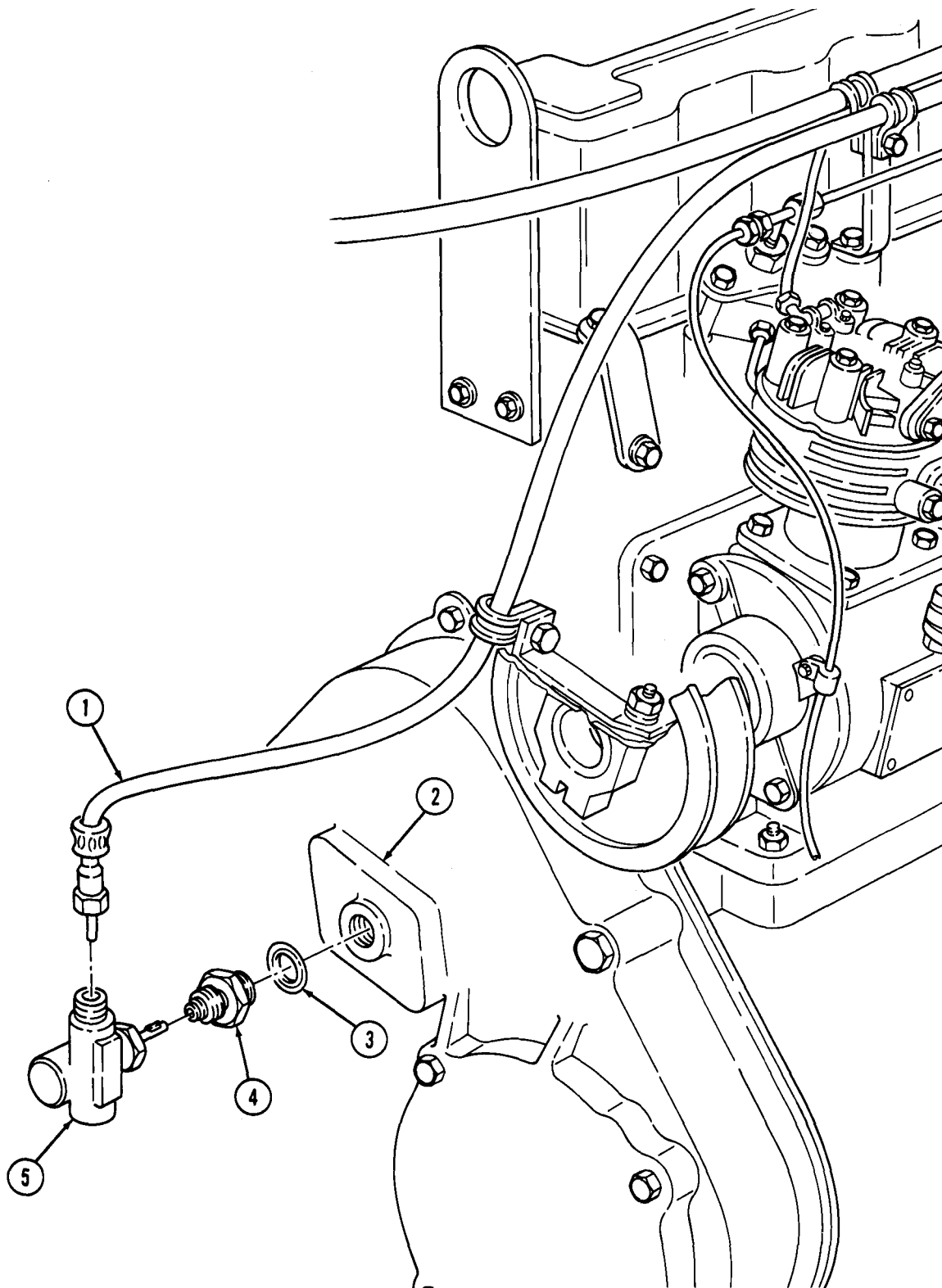

FOLLOW-ON TASK: Install radiator (para. 3-42).



## 4-16. SPEEDOMETER DRIVESHAFT AND ADAPTER REPLACEMENT

This task covers:

- a. Speedometer Shaft Removal
- b. Speedometer Adapter Removal

- c. Speedometer Adapter Installation
- d. Speedometer Shaft Installation

INITIAL SETUP:

### APPLICABLE MODELS

All

### REFERENCES (TM)

LO 9-2320-209-12-1

TM 9-2320-361-10

TM 9-2320-361-20P

### EQUIPMENT CONDITION

- Parking brake set (TM 9-2320-361-10).
- Battery ground cable disconnected (para. 4-48).
- Front and center cab tunnels removed (para. 11-22).

### a. Speedometer Shaft Removal

1. Turn four lockstuds (4) 1/4 turn left and pull instrument cluster (5) away from instrument panel (14).
2. Remove speedometer driveshaft (2) from adapter (12).
3. Remove two nuts (7), clamps (6), screws (1), and speedometer driveshaft (2) from instrument panel (14) and floor (13).
4. Remove speedometer driveshaft (2) from speedometer (3).

### b. Speedometer Adapter Removal

1. Remove adapter (12) from transfer case (11).
2. Remove adapter shaft (10), sleeve (9), and driveshaft (8) from adapter (12).

### c. Speedometer Adapter Installation

1. Install driveshaft (8), sleeve (9), and adapter shaft (10) on adapter (12).
2. Install adapter (12) on transfer case (11).

### d. Speedometer Shaft Installation

1. Install speedometer driveshaft (2) on speedometer (3).
2. Install speedometer driveshaft (2) on instrument panel (14) and floor (13) with two clamps (6), screws (1), and nuts (7).
3. Install speedometer driveshaft (2) on adapter (12).
4. Position instrument cluster (5) on instrument panel (14) and lock in place by turning four lockstuds (4) 1/4 turn to right.

**4-16. SPEEDOMETER DRIVESHAFT AND ADAPTER REPLACEMENT (Contd)**

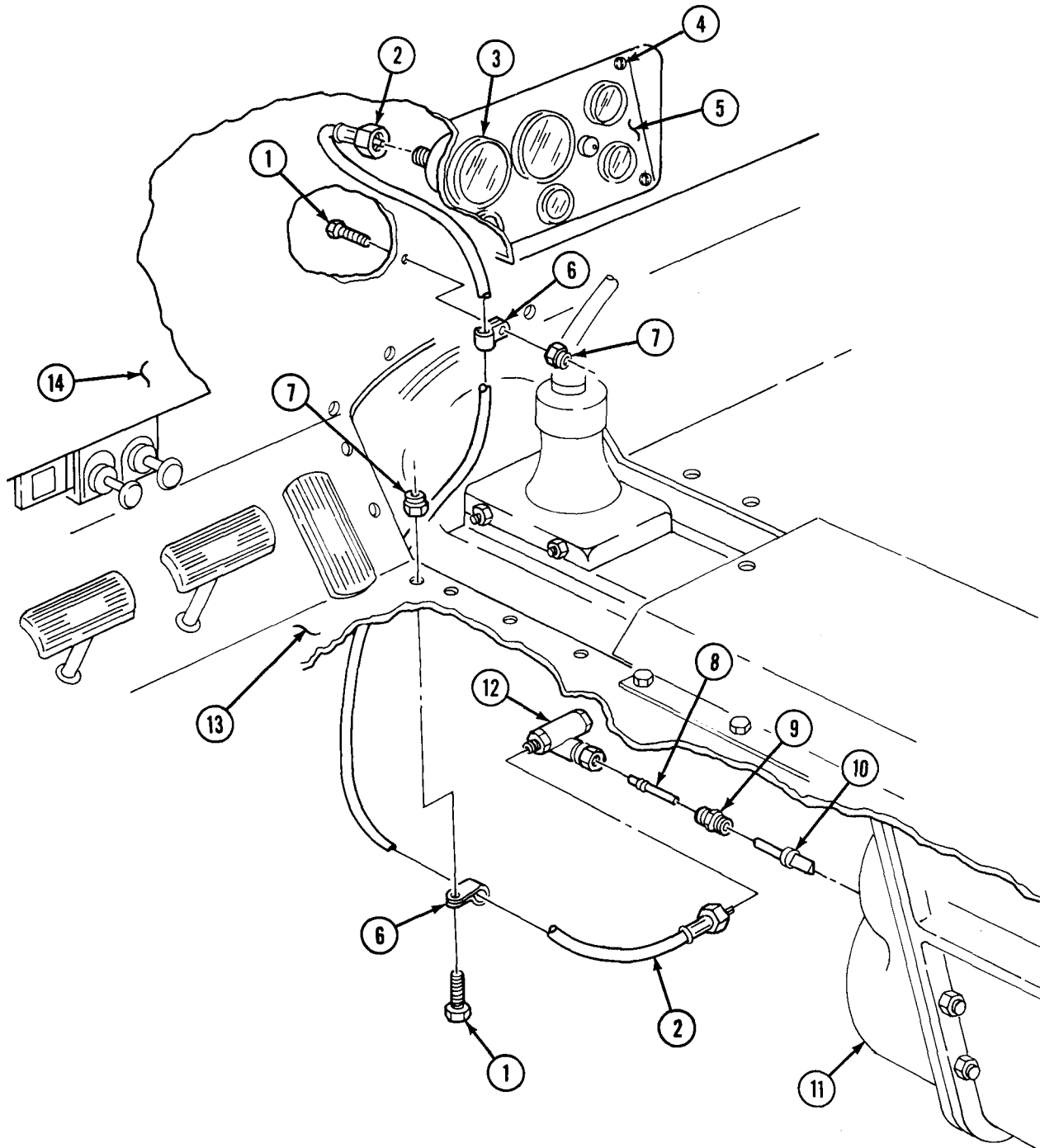

- FOLLOW-ON TASKS:
- ] Install front and center cab tunnels (para. 11-22).
  - ] Install battery ground cable (para. 4-48).
  - ] Lubricate adapter (LO 9-2320-209-12-1).

## 4-17. HEADLIGHT HIGH BEAM INDICATOR AND LAMP REPLACEMENT

This task covers:

**a. Removal**

**b. Installation**

INITIAL SETUP:

APPLICABLE MODELS

All

REFERENCES (TM)

TM 9-2320-361-10

TM 9-2320-361-20P

MATERIALS/PARTS

Two lockwashers

EQUIPMENT CONDITION

Parking brake set (TM 9-2320-361-10).

**NOTE**

Headlight high beam indicator assembly and the two instrument cluster light assemblies are removed and installed the same. This procedure covers the high beam indicator light.

**a. Removal**

1. Turn lens (2) to left and remove.
2. Push in and turn lamp (3) to left and remove.
3. Remove two screws (4), lockwashers (5), and headlight high beam indicator (6) from instrument cluster (1). Discard lockwashers (5).
4. Disconnect connector (7) from headlight high beam indicator (6).

**b. Installation**

1. Connect connector (7) to headlight high beam indicator (6).
2. Install headlight high beam indicator (6) in instrument cluster (1) with two new lockwashers (5) and screws (4).
3. Install lamp (3) on high beam indicator (6).
4. Install lens (2) over lamp (3).

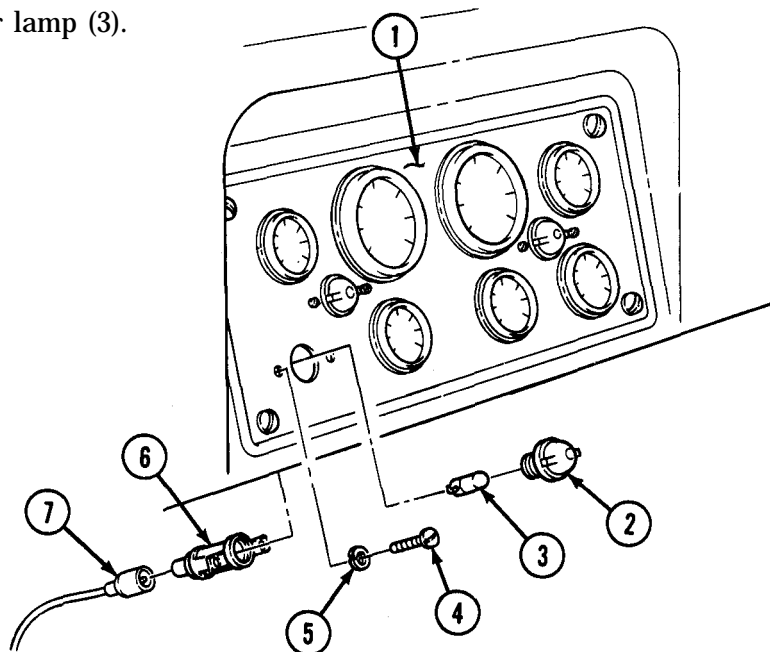

## 4-18. LIGHT SWITCH REPLACEMENT

This task covers:

### a. Removal

### b. Installation

INITIAL SETUP:

APPLICABLE MODELS  
All

REFERENCES (TM)  
TM 9-2320-361-10  
TM 9-2320-361-20P

MATERIALS/PARTS  
Three lockwashers

EQUIPMENT CONDITION

- Parking brake set (TM 9-2320-361-10).
- Battery ground cable disconnected (para. 4-48).

### a. Removal

1. Remove three screws (6), lockwashers (5), handles (4), and washers (3) from light switch (1). Discard lockwashers (5).
2. Remove four mounting screws (7) from instrument panel (2) and light switch (1). Push light switch (1) through instrument panel (2).
3. Disconnect front wiring harness connector (8) from light switch (1).

### b. Installation

1. Connect front wiring harness connector (8) to light switch (1).
2. Position light switch (1) through instrument panel (2) and install with four mounting screws (7).
3. Install three washers (3) and handles (4) on light switch (1) with three new lockwashers (5) and screws (6).

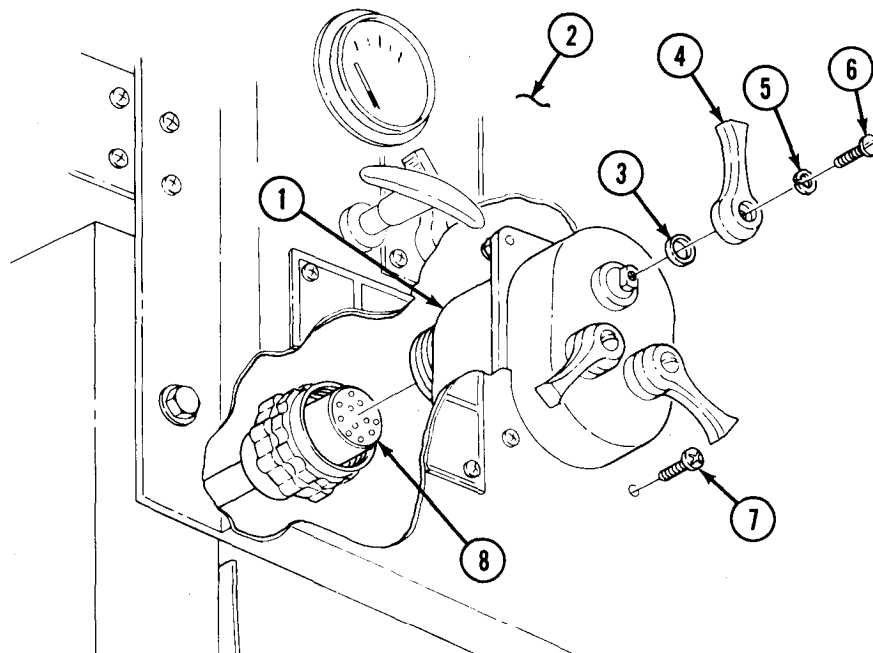

FOLLOW-ON TASKS: • Connect battery ground cable (para. 4-48).  
• Check lights for proper operation (TM 9-2320-361-10).

**4-19. TURN SIGNAL CONTROL AND INDICATOR LAMP REPLACEMENT**

This task covers:

**a. Removal**

**b. Installation**

**INITIAL SETUP:**

APPLICABLE MODELS

All

EQUIPMENT CONDITION

Z Parking brake set (TM 9-2320-361-10).

- Battery ground cable disconnected (para. 4-48).

REFERENCES (TM)

TM 9-2320-361-10

TM 9-2320-361-20P

**a. Removal**

1. Remove cable connector (5) from turn signal control (4).
2. Remove clamp (2) and turn signal control (4) from steering column (3).
3. Turn lamp lens (1) 1/2 turn to left and remove from turn signal control (4).
4. Remove lamp (7) from lamp socket (6).

**b. Installation**

1. Install lamp (7) in lamp socket (6).
2. Install lamp lens (1) in turn signal control (4) and rotate 1/2 turn to right.
3. Install turn signal control (4) on steering column (3) with clamp (2).
4. Connect cable connector (5) to turn signal control (4).

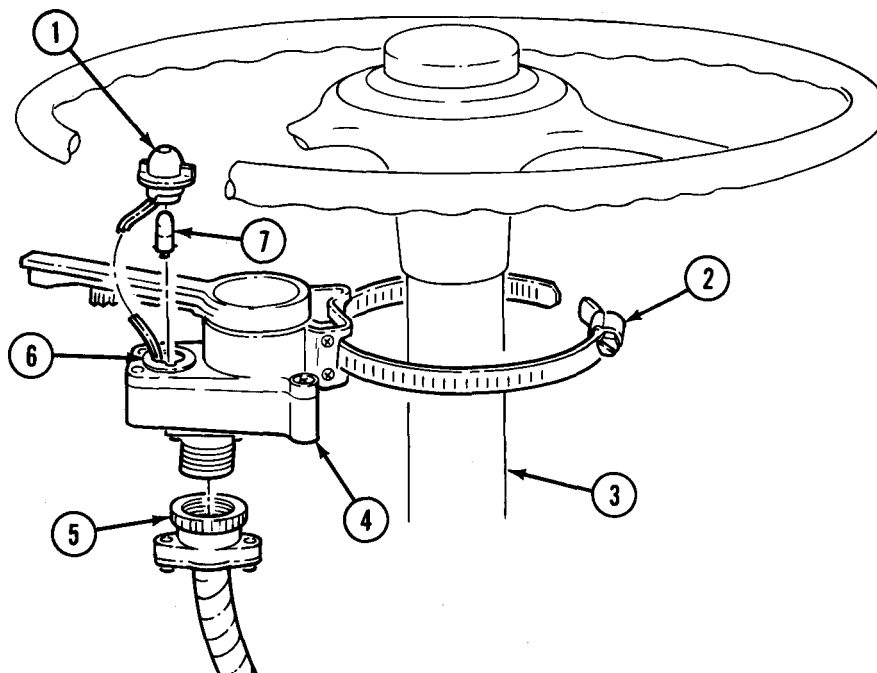

**FOLLOW-ON TASKS:** Z Connect battery ground cable (para. 4-48).  
 • Check turn signal control for proper operation (TM 9-2320-361-10).

## 4-20. TURN SIGNAL FLASHER REPLACEMENT

This task covers:

### a. Removal

### b. Installation

INITIAL SETUP:

#### APPLICABLE MODELS

All

#### MATERIALS/PARTS

Four lockwashers

#### REFERENCES (TM)

TM 9-2320-361-10

TM 9-2320-361-20P

#### EQUIPMENT CONDITION

- Parking brake set (TM 9-2320-361-10).
- Hood raised and secured (TM 9-2320-361-10).
- Battery ground cable disconnected (para. 4-48).

### a. Removal

1. Disconnect cable connector (4) from turn signal flasher (10).
2. Remove nut (1), lockwasher (2), ground wire (3), screw (7), and lockwasher (6) from turn signal flasher (10). Discard lockwashers (2) and (6).
3. Remove nut (12), lockwasher (11), screw (9), lockwasher (8), and turn signal flasher (10) from left front fender (5). Discard lockwashers (11) and (8).

### b. Installation

1. Install turn signal flasher (10) on left front fender (5) with screw (9), two new lockwashers (8) and (11), and nut (12).
2. Install screw (7), new lockwasher (6), ground wire (3), new lockwasher (2), and nut (1).
3. Connect cable connector (4) to turn signal flasher (10).

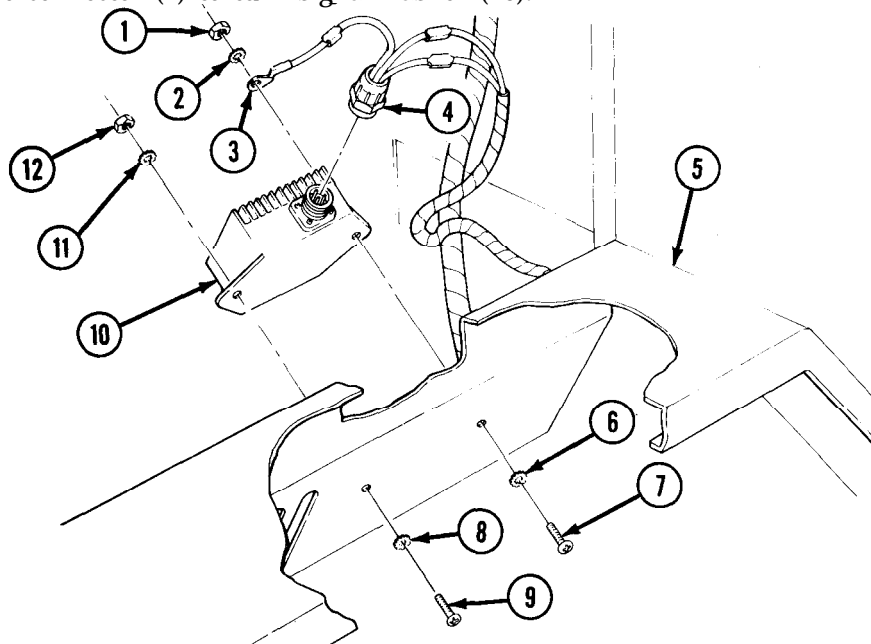

- FOLLOW-ON TASKS:
- Connect battery ground cable (para. 4-48).
  - Operate turn signal control to check turn signal flasher (TM 9-2320-361-10).

## 4-21. ACCESSORY SWITCH REPLACEMENT

This task covers:

**a. Removal**

**b. Installation**

INITIAL SETUP:

APPLICABLE MODELS

All

REFERENCES (TM)

TM 9-2320-361-10

TM 9-2320-361-20P

MATERIALS/PARTS

Two lockwashers

EQUIPMENT CONDITION

• Parking brake set (TM 9-2320-361-10).

• Battery ground cable disconnected (para. 4-48).

### a. Removal

1. Remove screw (9), lockwasher (10), and handle (8) from switch (4). Discard lockwasher (10).
2. Remove nut (7), lockwasher (6), and switch plate (1) from switch (4). Discard lockwasher (6).
3. Remove switch (4) from instrument panel (5).

**NOTE**

Tag wires for installation.

4. Disconnect wires (11), (12), (13), and (14) from switch (4).

### b. Installation

1. Connect wires (11), (12), (13), and (14) to switch (4).
2. Install switch (4) and switch plate (1) on instrument panel (5) with new lockwasher (6) and nut (7). Position locator tab (3) in hole (2).
3. Install handle (8) on switch (4) with new lockwasher (10) and screw (9).

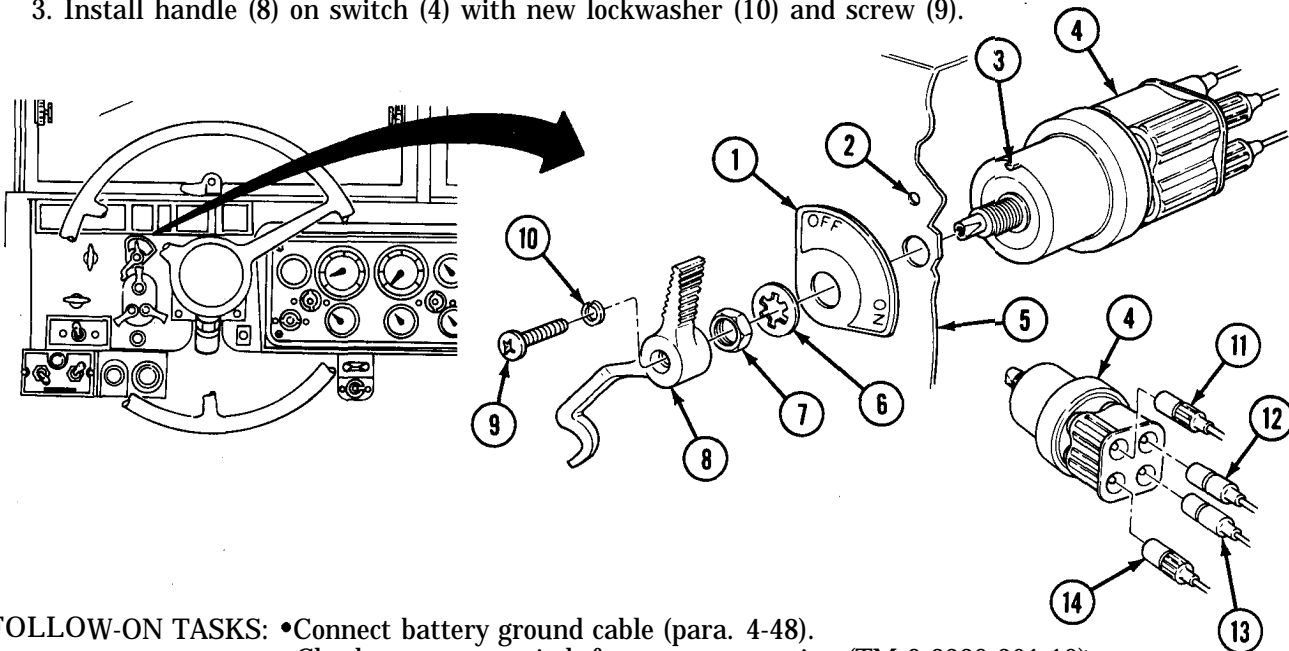

- FOLLOW-ON TASKS:**
- Connect battery ground cable (para. 4-48).
  - Check accessory switch for proper operation (TM 9-2320-361-10).

## 4-22. MANIFOLD HEATER SWITCH REPLACEMENT

This task covers:

### a. Removal

### b. Installation

#### INITIAL SETUP:

##### APPLICABLE MODELS

All

##### REFERENCES (TM)

TM 9-2320-361-10

TM 9-2320-361-20P

##### EQUIPMENT CONDITION

- Parking brake set (TM 9-2320-361-10).
- Battery ground cable disconnected (para. 4-48).

### a. Removal

1. Remove two screws (3) and manifold heater switch (6) from instrument panel (4).

#### NOTE

Tag all wires for installation.

2. Disconnect wires (1) and (7) and remove manifold heater switch (6).

### b. Installation

1. Connect wires (1) and (7) to manifold heater switch (6).
2. Push switch lever (5) through hole (2) in instrument panel (4). Be sure switch lever (5) is positioned toward OFF marked on data plate.
3. Install manifold heater switch (6) on instrument panel (4) with two screws (3).

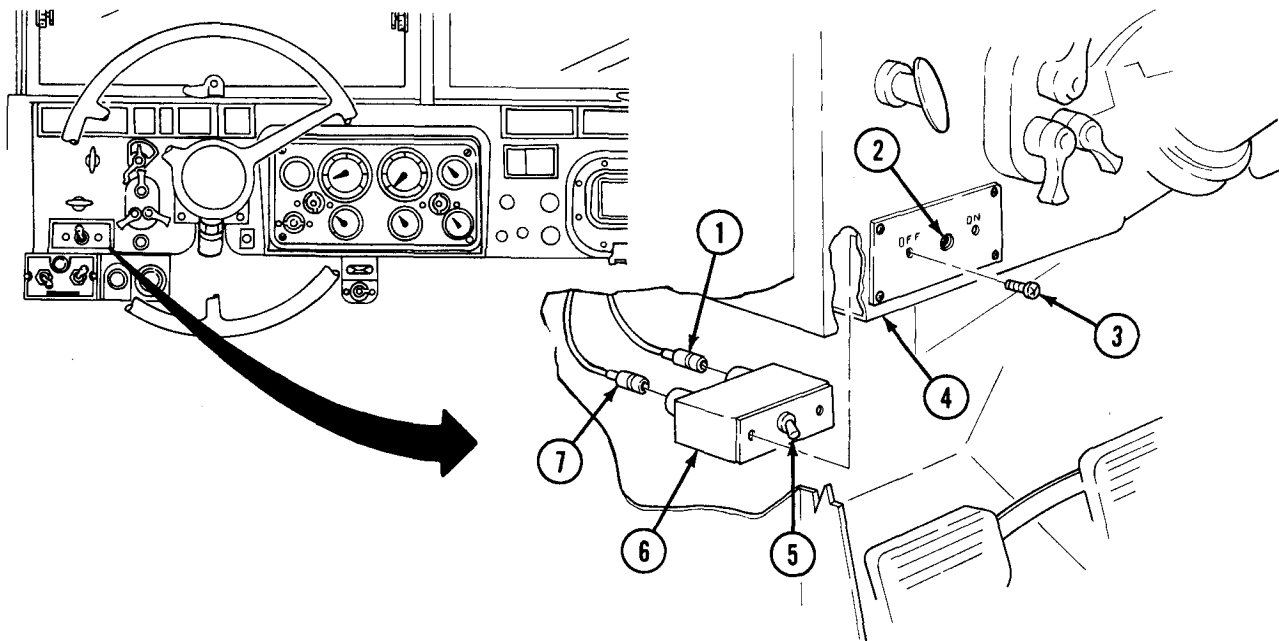

- FOLLOW-ON TASKS:
- Connect battery ground cable (para. 4-48).
  - Start engine (TM 9-2320-361-10) and check operation of manifold heater switch.



## 4-23. OIL PRESSURE SENDING UNIT REPLACEMENT

This task covers:

**a. Removal**

**b. Installation**

**INITIAL SETUP:**

APPLICABLE MODELS

All

MATERIALS/PARTS

Antiseize tape (Appendix C, Item 27)

REFERENCES (TM)

TM 9-2320-361-10

TM 9-2320-361-20P

EQUIPMENT CONDITION

- Parking brake set (TM 9-2320-361-10).
- Hood raised and secured (TM 9-2320-361-10).
- Battery ground cable disconnected (para. 4-48).
- Remove air cleaner assembly (para. 3-15).

**CAUTION**

The 60 psi and 120 psi gages and sending units are not interchangeable. Do not interchange the 60 psi gage or sending unit with a 120 psi gage or sending unit.

**NOTE**

Do not remove elbow and adapter unless items require replacement.

1. Disconnect wire (1) from oil pressure sending unit (2).
2. Remove oil pressure sending unit (2) from adapter fitting (3).
3. Remove adapter fitting (3) and elbow (4) from engine (5).

**NOTE**

Clean all male pipe threads and wrap with antiseize tape before installation.

1. Install elbow (4) and adapter fitting (3) on engine (5).
2. Install oil pressure sending unit (2) in adapter (3).
3. Connect wire (1) to oil pressure sending unit (2).

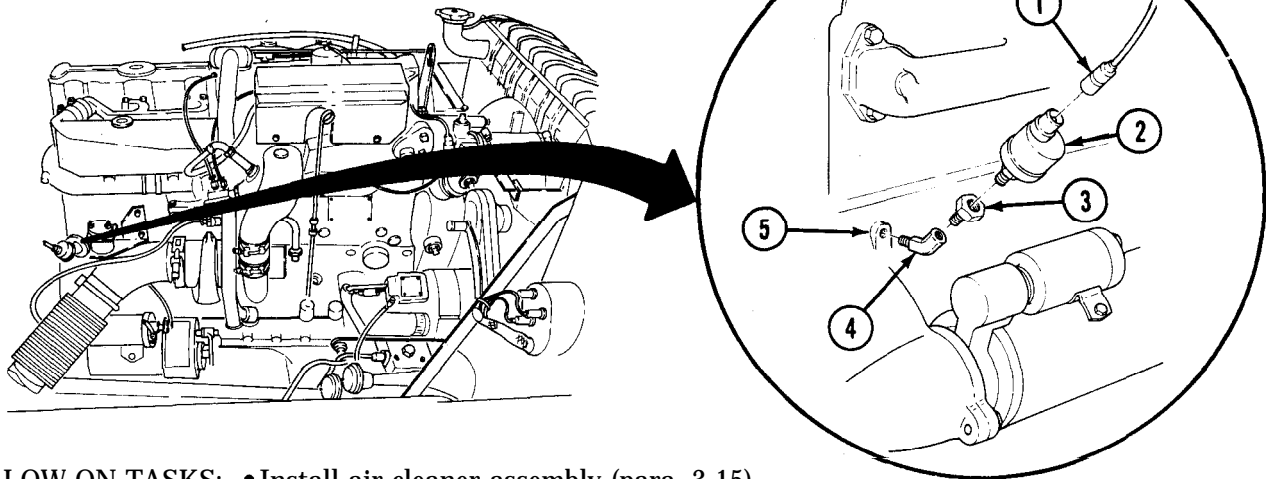

- FOLLOW-ON TASKS:**
- Install air cleaner assembly (para. 3-15).
  - Connect battery ground cable (para. 4-48).
  - Start engine (TM 9-2320-361-10) and check for oil leaks around adapter and elbow.
  - Check for proper operation of oil pressure gage (TM 9-232-361-10).

## 4-24. ENGINE TEMPERATURE SENDING UNIT REPLACEMENT

This task covers:

### a. Removal

### b. Installation

INITIAL SETUP:

#### APPLICABLE MODELS

All

#### MATERIALS/PARTS

Sealing compound (Appendix C, Item 23)

#### REFERENCES (TM)

TM 9-2320-361-10

TM 9-2320-361-20P

#### EQUIPMENT CONDITION

- Parking brake set (TM 9-2320-361-10).
- Hood raised and secured (TM 9-2320-361-10).
- Battery ground cable disconnected (para. 4-48).
- Cooling system (eight quarts) drained so that coolant level is below engine intake manifold (para. 3-41).

### a. Removal

1. Disconnect wire (2) from engine temperature sending unit (3).
2. Remove engine temperature sending unit (3) from intake manifold (1).

### b. Installation

#### **NOTE**

Clean all male pipe threads and coat with sealing compound before installation.

1. Install engine temperature sending unit (3) in intake manifold (1).
2. Connect wire (2) to engine temperature sending unit (3).

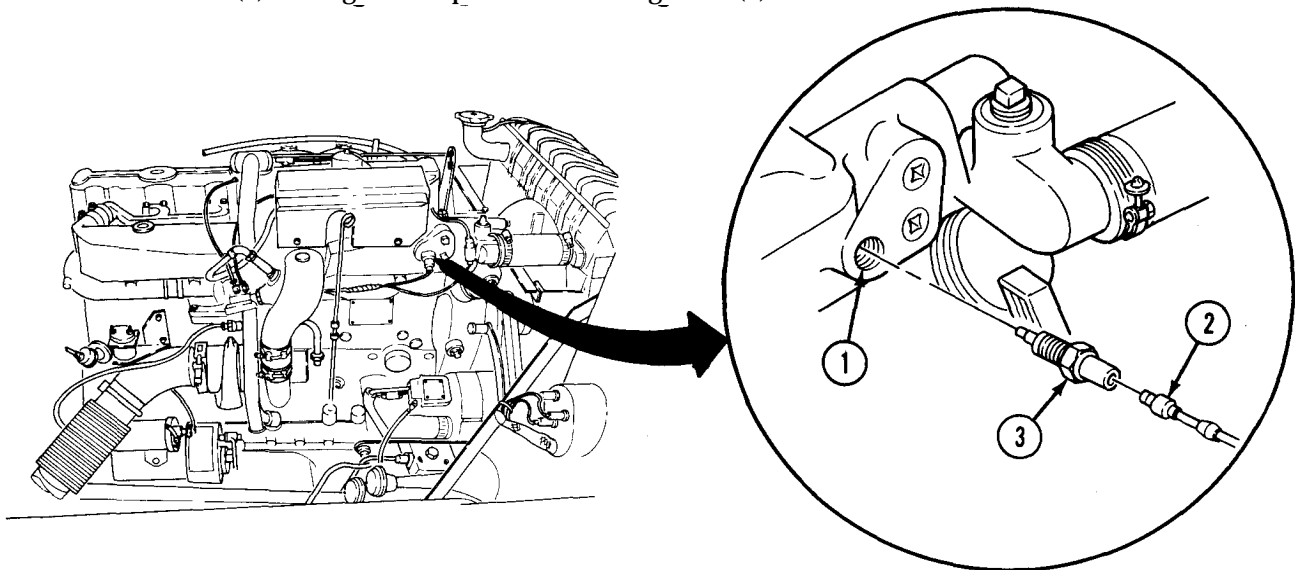

- FOLLOW-ON TASKS:
- Connect battery ground cable (para. 4-48).
  - Fill cooling system (para. 3-41).
  - Start engine (TM 9-2320-361-10) and check for coolant leaks at water manifold.
  - Check coolant temperature gage for proper operation.

## 4-25. LOW AIR PRESSURE SWITCH REPLACEMENT

This task covers:

**a. Removal**

**b. Installation**

**INITIAL SETUP:**

APPLICABLE MODELS

All

REFERENCES (TM)

TM 9-2320-361-10

TM 9-2320-361-20P

MATERIALS/PARTS

Antiseize tape (Appendix C, Item 27)

EQUIPMENT CONDITION

- Parking brake set (TM 9-2320-361-10).
- Battery ground cable disconnected (para. 4-48).

**NOTE**

Tag wires for installation.

1. Disconnect wires (1) and (4) from low air pressure switch (2).
2. Remove low air pressure switch (2) from tube and hose manifold (3).

**NOTE**

Clean all male pipe threads, and wrap with antiseize tape before installation.

1. Install low air pressure switch (2) in tube and hose manifold (3).
2. Connect wires (1) and (4) to low air pressure switch (2).

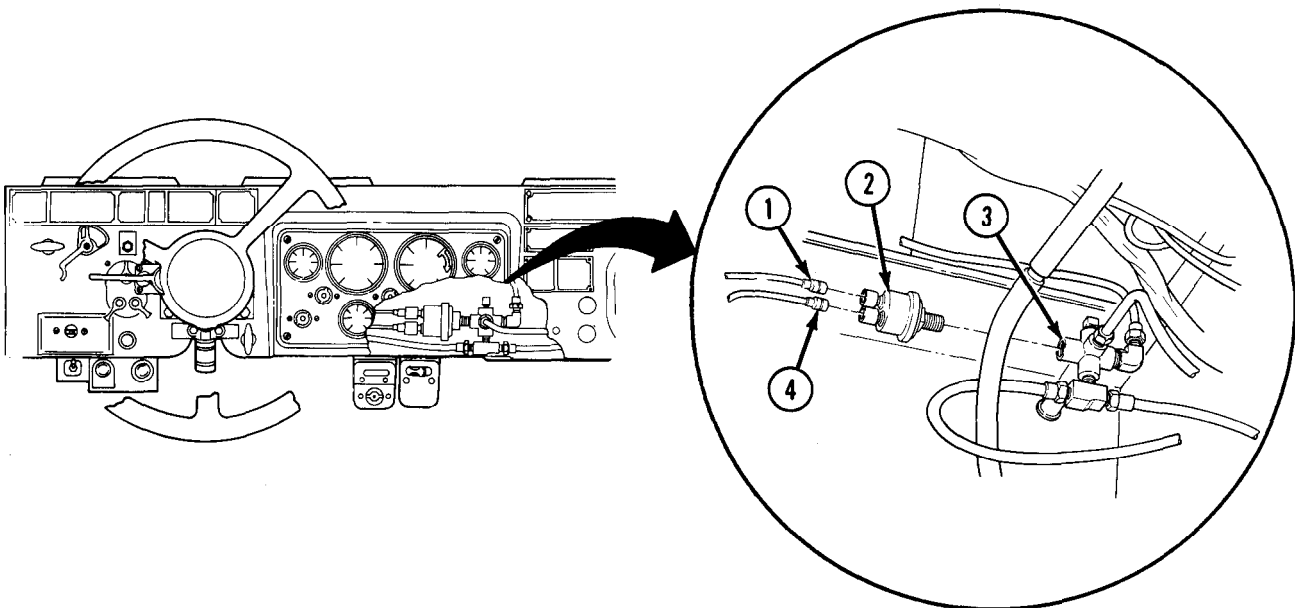

- FOLLOW-ON TASKS:**
- Connect battery ground cable (para. 4-48)
  - Start engine (TM 9-2320-361-10) and check low air pressure switch operation.

## 4-26. FUEL LEVEL SENDING UNIT REPLACEMENT

This task covers:

### a. Removal

### b. Installation

INITIAL SETUP:

#### APPLICABLE MODELS

All

#### MATERIALS/PARTS

Gasket

#### REFERENCES (TM)

TM 9-2320-361-10

TM 9-2320-361-20P

#### EQUIPMENT CONDITION

- Parking brake set (TM 9-2320-361-10).
- Battery ground cable disconnected (para. 4-48).
- Spare tire removed (M342A2), (TM 9-2320-361-10).
- Fuel tank removed (M275A2, M756A2, M185A3, and M109A3) (para. 3-24 or 3-25).

#### GENERAL SAFETY INSTRUCTIONS

Diesel fuel is flammable. Do not perform this procedure near open flames.

### WARNING

Diesel fuel is flammable. Do not perform fuel system procedures near open flame. Injury or death to personnel may result.

### a. Removal

1. Disconnect wire (3) from sending unit (4).
2. Remove five screws (2) and copper washers (1) from sending unit (4).
3. Remove sending unit (4) and gasket (5) from fuel tank (6). Clean gasket remains from mating surfaces. Discard gasket (5).

### b. Installation

1. Install new gasket (5) and sending unit (4) on fuel tank (6) with five copper washers (1) and screws (2).
2. Connect wire (3) to sending unit (4).

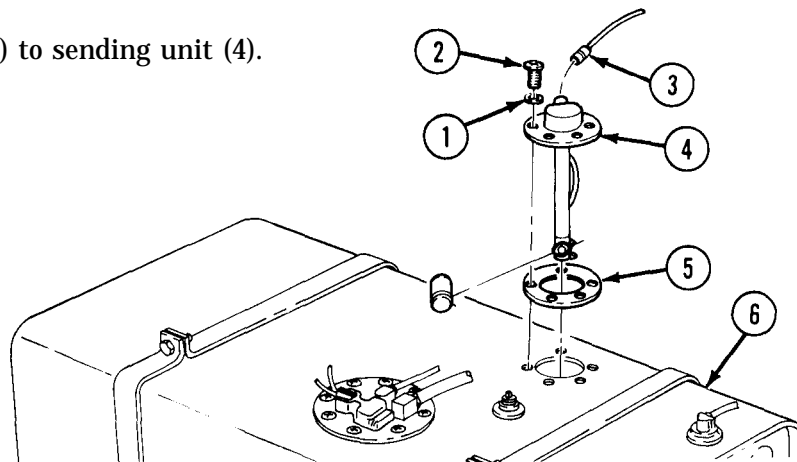

- FOLLOW-ON TASKS:
- Install spare tire (TM 9-2320-361-10).
  - Install fuel tank (para. 3-24 or 3-25).
  - Connect battery ground cable (para. 4-48).
  - Start engine (TM 9-2320-361-10) and check fuel gage for proper operation.

**4-27. LOW AIR BUZZER REPLACEMENT**

This task covers:

**a. Removal**

**b. Installation**

INITIAL SETUP:

APPLICABLE MODELS

All

MATERIALS/PARTS

Seven lockwashers

PERSONNEL REQUIRED

Two

REFERENCES (TM)

TM 9-2320-361-10

TM 9-2320-361-20P

EQUIPMENT CONDITION

- Parking brake set (TM 9-2320-361-10).
- Battery ground cable disconnected (para. 4-48).

**a. Removal**

1. Disconnect wire (13) from low air buzzer (3).
2. Remove two nuts (1) and lockwashers (2) from two stud mounts (4). Discard lockwashers (2).
3. Remove nut (15) and lockwasher (14) from stud mount (11). Discard lockwasher (14).
4. Bend ground strap (12) outward and remove low air buzzer (3) from two stud mounts (4) and stud mount (11).

**NOTE**

Assistant will help with steps 5 and 6.

5. Remove two nuts (7), lockwashers (6), and mounting studs (4) from firewall (5). Discard lockwashers (6).
6. Remove nut (9), lockwasher (8), stud mount (11), ground strap (12), and lockwasher (10) from firewall (5). Discard lockwashers (8) and (10).

**b. Installation**

**NOTE**

Assistant will help with steps 1 and 2.

1. Install stud mount (11) and ground strap (12) on firewall (5) with two new lockwashers (10) and (8) and nut (9).
2. Install two stud mounts (4) in firewall (5) with two new lockwashers (6) and nuts (7).
3. Install low air buzzer (3) on two stud mounts (4) and stud mount (11).
4. Lift end of ground strap (12) and secure on stud mount (11) with new lockwasher (14) and nut (15).
5. Install two new lockwashers (2) and nuts (1) on stud mounts (4).
6. Connect wire (13) to low air buzzer (3).

## 4-27. LOW AIR BUZZER REPLACEMENT (Contd)

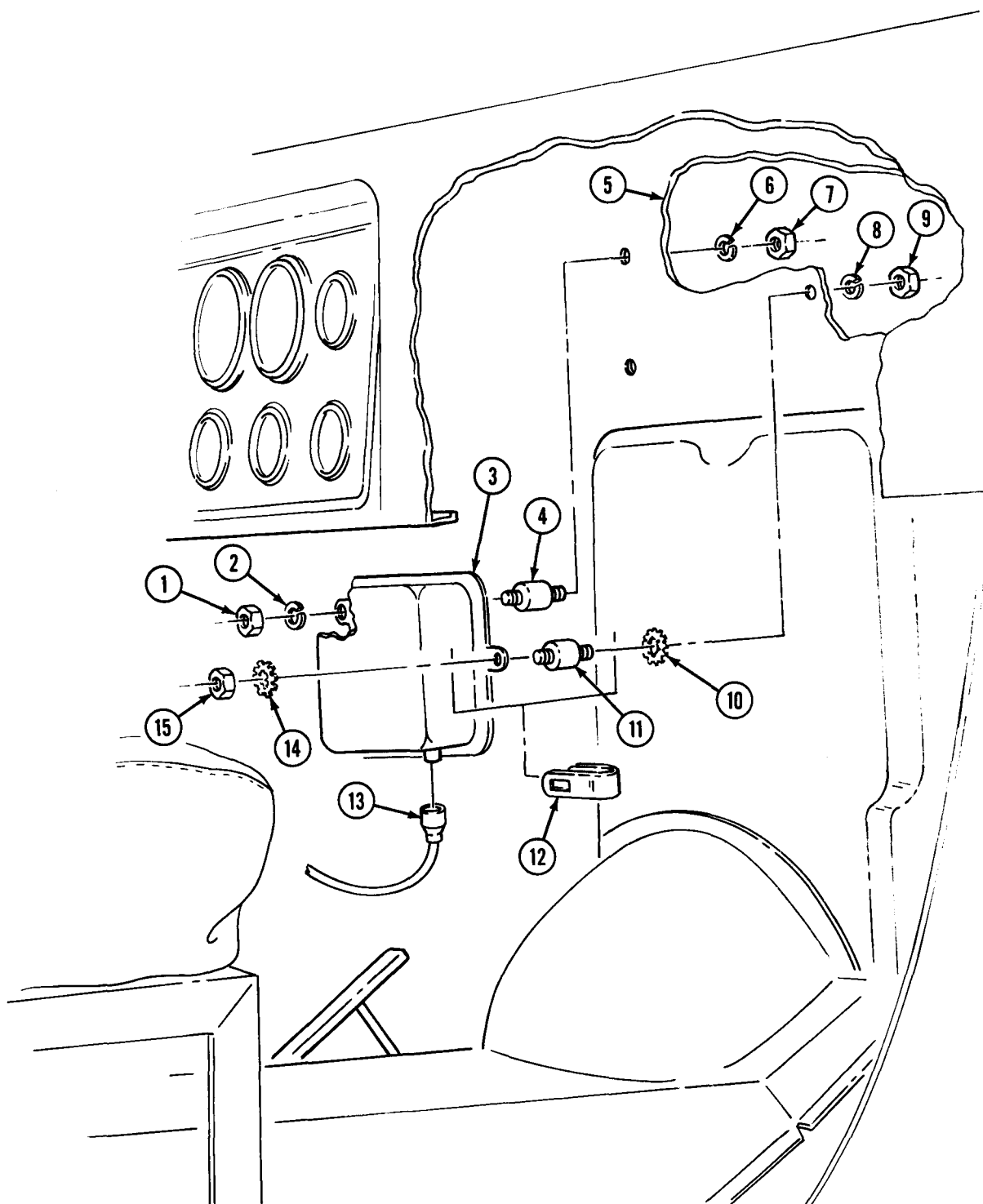

- FOLLOW-ON TASKS:
- Connect battery ground cable (para. 4-48).
  - Start engine (TM 9-2320-361-10) and check low air buzzer operation.

## 4-28. HEADLIGHT DIMMER SWITCH REPLACEMENT

This task covers:

### a. Removal

### b. Installation

#### INITIAL SETUP:

#### APPLICABLE MODELS

All

#### MATERIALS/PARTS

Two lockwashers

#### PERSONNEL REQUIRED

TWO

#### REFERENCES (TM)

TM 9-2320-361-10

TM 9-2320-361-20P

#### EQUIPMENT CONDITION

- Parking brake set (TM 9-2320-361-10).
- Battery ground cable disconnected (para. 4-48).

### a. Removal

1. Remove two screws (1) and lockwashers (9). Discard lockwashers (9).
2. Push dimmer switch plunger (4) through floorboard (2) and slide dimmer switch (8) away from protective cover (3).

#### NOTE

Tag wires for installation.

3. Disconnect wires (5), (6), and (7) from dimmer switch (8).

### b. Installation

1. Connect three wires (5), (6), and (7) to dimmer switch (8).

#### NOTE

Assistant will help with steps 2 and 3.

2. Position dimmer switch plunger (4) through floorboard (2) and install with two new lockwashers (9) and screws (1). Do not tighten screws (1).
3. Position protective cover (3) over dimmer switch (8). Slide slotted side of cover (3) on dimmer switch (8) and floorboard (2). Tighten screws (1).

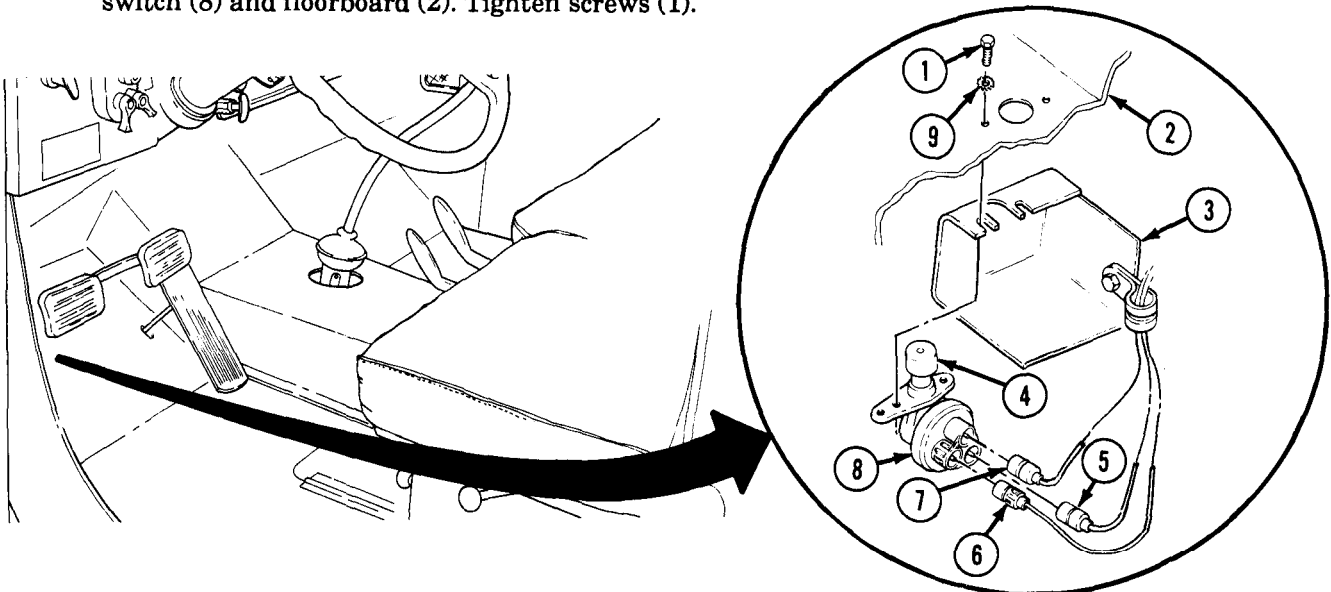

- FOLLOW-ON TASKS:
- Connect battery ground cable (para. 4-48).
  - Check operation of headlight dimmer switch (TM 9-2320-361-10).

## 4-29. STOPLIGHT SWITCH REPLACEMENT

This task covers:

### a. Removal

### b. Installation

#### INITIAL SETUP:

##### APPLICABLE MODELS

All (except M275A2)

##### REFERENCES (TM)

TM 9-2320-361-10

TM 9-2320-361-20P

##### EQUIPMENT CONDITION

- Parking brake set (TM 9-2320-361-10).
- Battery ground cable disconnected (para. 4-48).

### a. Removal

1. Remove two screws (7) and shield (6) from mounting bracket (1).

#### **NOTE**

Tag wires for installation.

2. Disconnect wires (2) and (3) from stoplight switch (4).
3. Remove stoplight switch (4) from tee (5).

### b. Installation

1. Install stoplight switch (4) on tee (5).
2. Connect wires (2) and (3) to stoplight switch (4).
3. Install shield (6) to mounting bracket (1) with two screws (7).

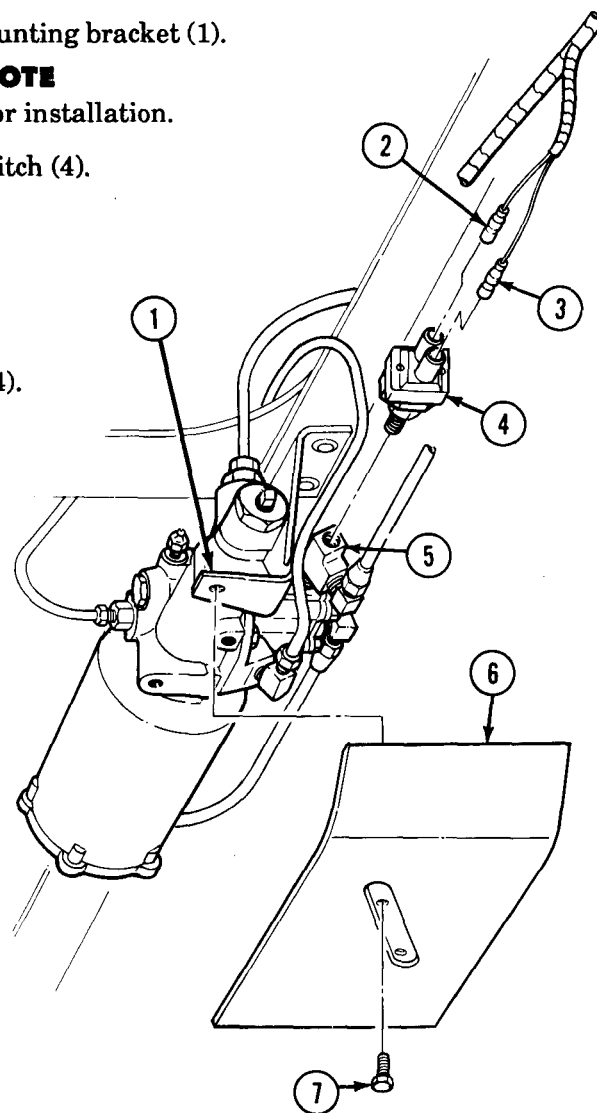

- FOLLOW-ON TASKS:
- Connect battery ground cable (para. 4-48).
  - Turn light switch to stoplight position and check stoplight operation by pressing brake pedal several times (TM 9-2320-361-10).



## 4-30. HORN BUTTON REPLACEMENT

This task covers:

**a. Removal**

**b. Installation**

INITIAL SETUP:

APPLICABLE MODELS

All

MATERIALS/PARTS

O-ring

Safety wire (Appendix C, Item 22)

REFERENCES (TM)

TM 9-2320-361-10

TM 9-2320-361-20P

EQUIPMENT CONDITION

- Parking brake set (TM 9-2320-361-10).
- Battery ground cable disconnected (para. 4-48).

### a. Removal

1. Remove three screws (4) and lift horn button adapter (3) from top of steering wheel (1). Disconnect horn button connector (7) from wire connector (10).
2. Remove spring (9) and seal (2).
3. Remove retaining ring (6), horn button (5), and O-ring (8) from adapter (3). Discard O-ring (8).

**NOTE**

Perform steps 4 through 8 only if horn wire is damaged.

4. Disconnect plug (16) from connector (15) and slide shell (14) back on horn wire (12).
5. Remove slotted washer (18) from behind connector (15) and slide shell (14) off end of wire (12).
6. Remove rubber bushing (13) from steering gearbox (19) and slide off end of wire (12).

**NOTE**

Safety wire must be long enough to reach from other end of steering column plus two additional feet.

7. Attach safety wire (17) to horn wire (12).

**NOTE**

Safety wire must be left inside steering column. It will be used to pull new horn wire through steering column.

8. Pull horn wire (12) through steering column (11). Leave safety wire (17) in steering column (11).

### b. Installation

**NOTE**

If horn wire has not been removed, proceed to step 6.

1. Pull horn wire (12) through steering column (11). Make sure horn wire (12) is taut between steering column (11) and connector (15). Discard safety wire (17).
2. Install rubber bushing (13) on horn wire (12) and into hole in steering gearbox (19).
3. Move shell (14) upward on wire (12) and install slotted washer (18) behind connector (15). Slide shell (14) over slotted washer (18).
4. Connect plug (16) to connector (15).
5. Install spring (9) and seal (2) in steering column (11).
6. Install retaining ring (6), horn button (5), and new O-ring (8) in adapter (3).
7. Connect wire connector (10) to horn button connector (7).
8. Install horn adapter (3) in steering column (11) and steering wheel (1) with three screws (4).

4-30. HORN BUTTON REPLACEMENT (Contd)

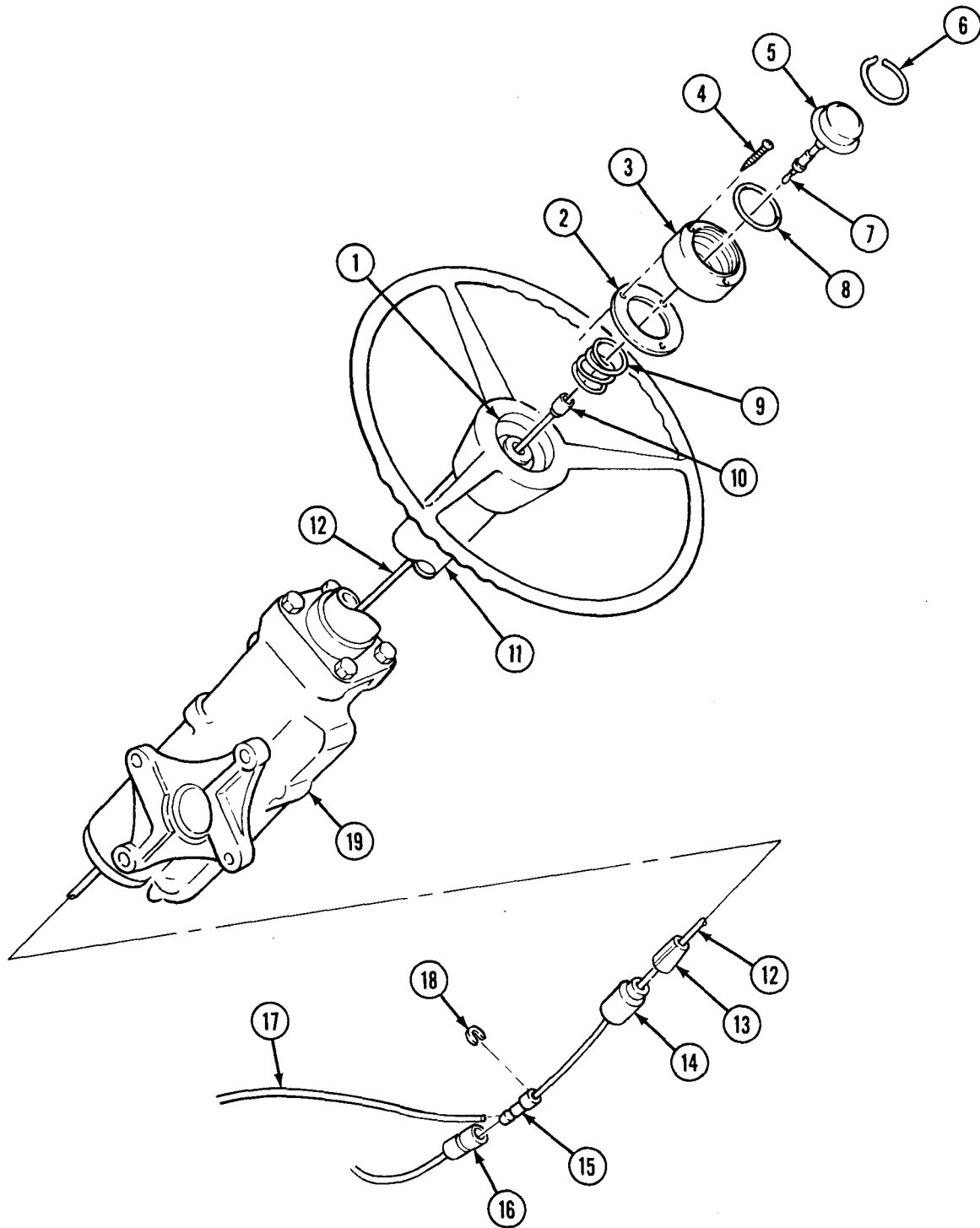

- FOLLOW-ON TASKS:
- Connect battery ground cable (para. 4-48).
  - Check horn for proper operation.

## 4-31. AIR HORN, SOLENOID, AND BRACKET REPLACEMENT

This task covers:

- a. **Solenoid Removal**
- b. **Air Horn Removal**

- c. **Air Horn Installtion**
- d. **Solenoid Installation**

### INITIAL SETUP:

#### APPLICABLE MODELS

All

#### MATERIALS/PARTS

Four lockwashers  
Antiseize tape (Appendix C, Item 27)

#### REFERENCES (TM)

TM 9-2320-361-10  
TM 9-2320-361-20P

#### EQUIPMENT CONDITION

- Parking brake set (TM 9-2320-361-10).
- Hood raised and secured (TM 9-2320-361-10).
- Battery ground cable disconnected (para. 4-48).
- Air reservoirs drained (TM 9-2320-361-10).

#### GENERAL SAFETY INSTRUCTIONS

Do not disconnect air lines before draining air reservoirs.

### a. Solenoid Removal

#### WARNING

Do not disconnect air lines before draining air reservoirs. Small parts under pressure may shoot out with high velocity, causing injury to personnel.

1. Disconnect air line (2) from elbow (3).
2. Remove elbow (3) from air solenoid (4).

#### **NOTE**

Tag wires for installation.

3. Disconnect wire plugs (5) and (6) from air solenoid (4).
4. Remove air solenoid (4) and nipple (7) from air horn (1).

### b. Air Horn Removal

1. Remove two nuts (10), lockwashers (11), screws (16), and air horn (1) from bracket (12). Discard lockwashers(11).
2. Remove two nuts (14), lockwashers (13), screws (9), and bracket (12) from fender (15) and brace (8). Discard lockwashers(13).

### c. Air Horn Installation

1. Install bracket (12) on fender (15) with brace (8), two screws (9), new lockwashers (13), and nuts (14).
2. Install air horn (1) on bracket (12) with two screws (16), new lockwashers (11), and nuts (10).

### d. Solenoid Installation

#### **NOTE**

Clean all male pipe threads and wrap with antiseize tape before installation.

1. Install nipple (7) and air solenoid (4) on air horn (1).
2. Install elbow (3) on air solenoid (4).

### 4-31. AIR HORN, SOLENOID, AND BRACKET REPLACEMENT (Contd)

3. Connect air line (2) to elbow (3).
4. Connect wire plugs (5) and (6) to air solenoid (4).

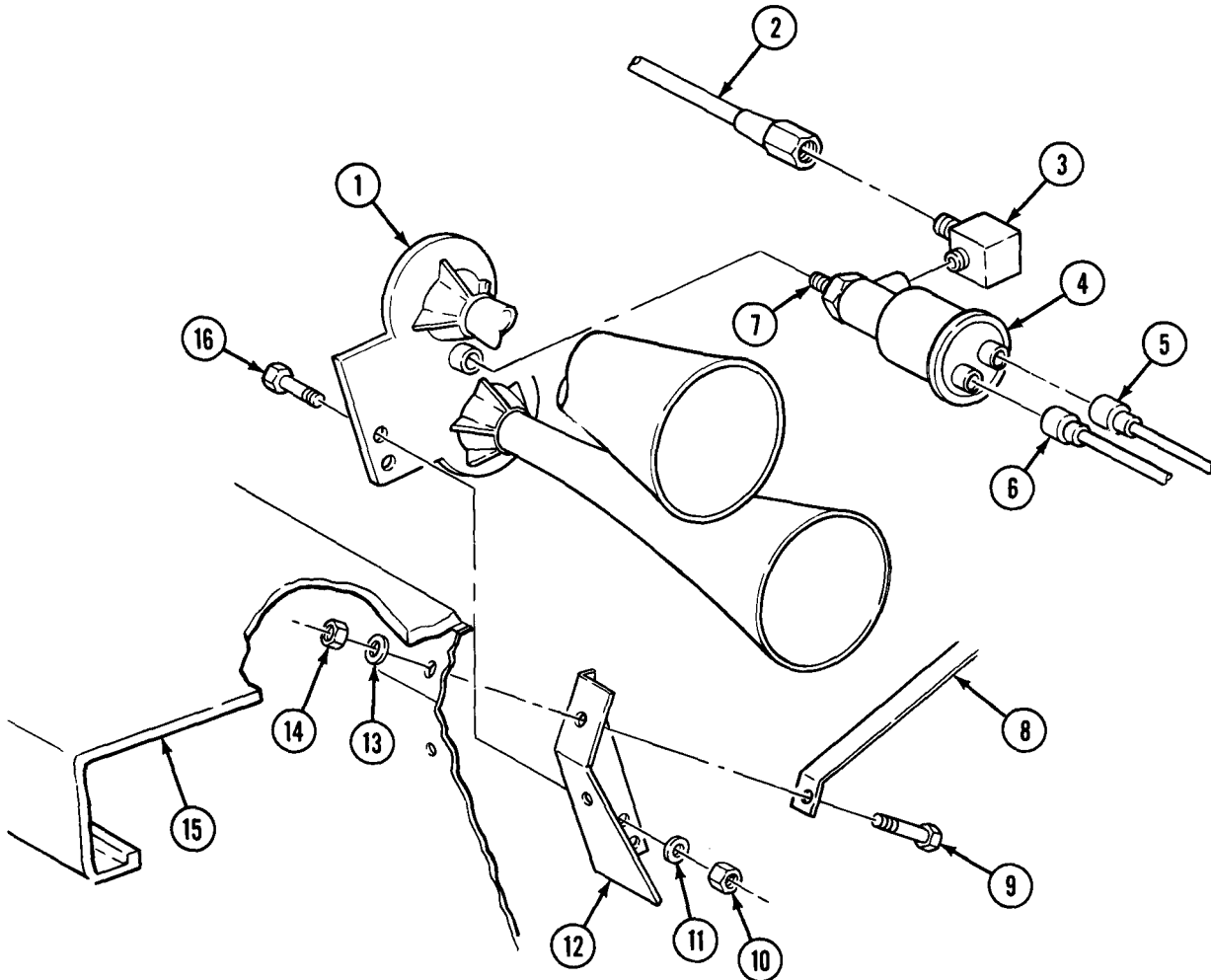

- FOLLOW-ON TASKS:
- Connect battery ground cables (para. 4-48).
  - Start engine (TM 9-2320-361-10) and allow air pressure to build up to normal operating range. Check for air leaks at horn solenoid.
  - Check horn for proper operation (TM 9-2320-361-10).

## 4-32. STOPLIGHT AIR PRESSURE SWITCH REPLACEMENT (M275A2)

This task covers:

### a. Removal

### b. Installation

#### INITIAL SETUP:

##### APPLICABLE MODELS

M275A2

##### MATERIALS/PARTS

Antiseize tape (Appendix C, Item 27)

##### REFERENCES (TM)

TM 9-2320-361-10

TM 9-2320-361-20P

##### EQUIPMENT CONDITION

- Parking brake set (TM 9-2320-361-10).
- Air reservoirs drained (TM 9-2320-361-10).
- Battery ground cable disconnected (para. 4-48).

##### GENERAL SAFETY INSTRUCTIONS

Do not disconnect air lines before draining air reservoirs.

### a. Removal

#### WARNING

Do not disconnect air lines before draining air reservoirs. Small parts under pressure may shoot out with high velocity causing injury to personnel.

#### NOTE

Tag wires for installation.

1. Disconnect wire plugs (4) and (5) from stoplight switch (3).
2. Remove stoplight switch (3) from adapter (2).
3. Remove adapter (2) from air valve (1).

### b. Installation

#### NOTE

Clean all male pipe threads and wrap with antiseize tape before installation.

1. Install adapter (2) on air valve (1).
2. Install stoplight switch (3) on adapter (2).
3. Connect wire plugs (4) and (5) to stoplight switch (3).

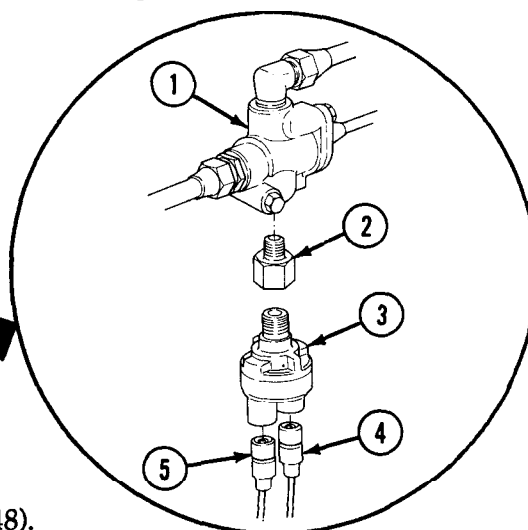
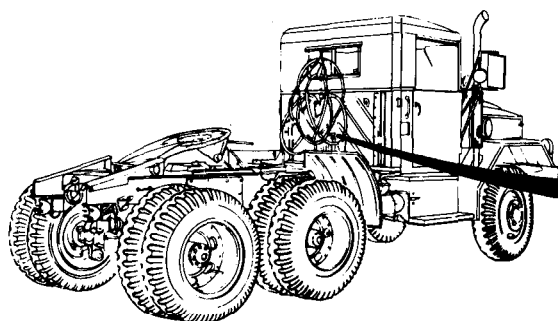

- FOLLOW-ON TASKS:**
- Connect battery ground cable (para. 4-48).
  - Start engine (TM 9-2320-361-10) and allow air pressure to build up to normal operating range. Check stoplights for proper operation.

## 4-33. CIRCUIT BREAKER REPLACEMENT

This task covers:

### a. Removal

### b. Installation

INITIAL SETUP:

#### APPLICABLE MODELS

All

#### REFERENCES (TM)

TM 9-2320-361-10

TM 9-2320-361-20P

#### EQUIPMENT CONDITION

- Parking brake set (TM 9-2320-361-10).
- Hood raised and secured (TM 9-2320-361-10).
- Battery ground cable disconnected (para. 4-48).

### a. Removal

#### NOTE

- Vehicle with auxiliary power outlets and personnel heaters have two additional circuit breakers located next to horn circuit breaker. Replacement procedures are the same for all circuit breakers.
- Tag wires for installation.

1. Disconnect wires (1) and (5) from circuit breaker (2).
2. Remove two screws (4) and circuit breaker (2) from firewall (3).

### b. Installation

1. Install circuit breaker (2) on firewall (3) with two screws (4).
2. Connect wires (1) and (5) to circuit breaker (2).

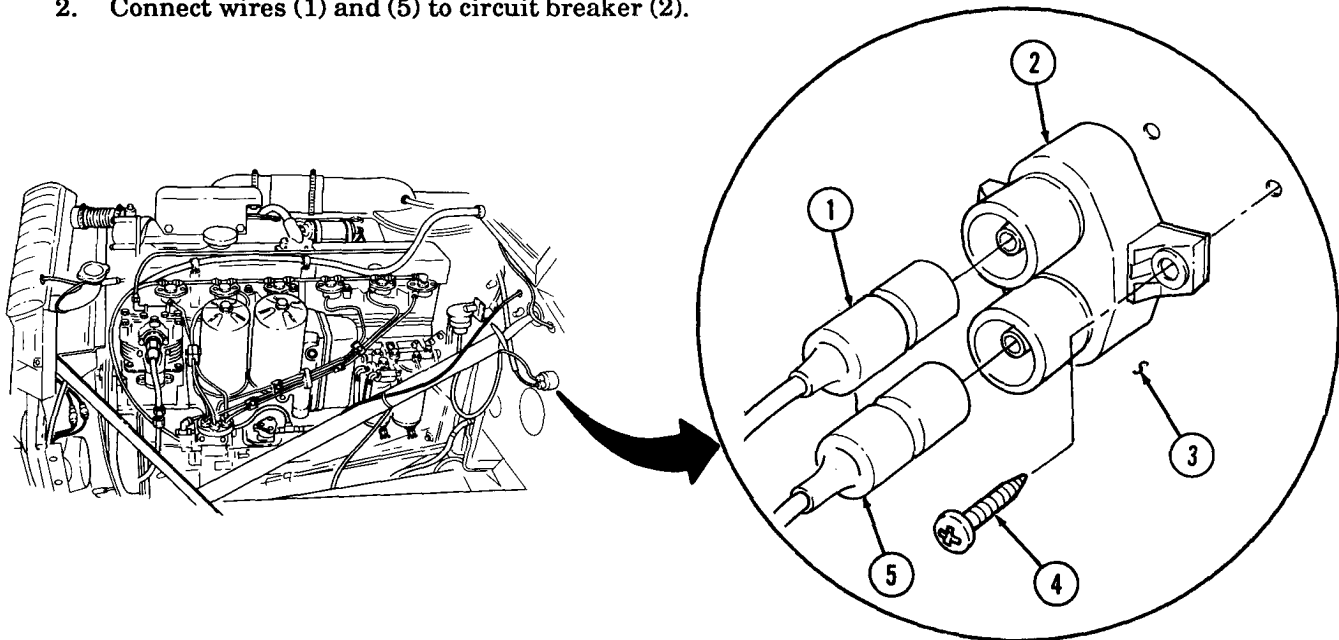

- FOLLOW-ON TASKS:
- Connect battery ground cable (para. 4-48).
  - Check operation of horn and personnel heater (TM 9-2320-361-10).

## 4-34. HOT WATER PERSONNEL HEATER CONTROL SWITCH REPLACEMENT

This task covers:

**a. Removal**

**b. Installation**

INITIAL SETUP:

APPLICABLE MODELS

All

MATERIALS/PARTS

Six lockwashers

REFERENCES (TM)

TM 9-2320-361-10

TM 9-2320-361-20P

EQUIPMENT CONDITION

- Parking brake set (TM 9-2320-361-10).
- Battery ground cable disconnected (para. 4-48).

### a. Removal

1. Remove nut (5), lockwasher (4), locking ring (3), and switch (6) from mounting bracket (2). Discard lockwasher (4).

**NOTE**

Tag leads for installation.

2. Remove three screws (9), lockwashers (8), and four wires (7) from switch (6). Discard lockwashers (8).
3. Remove two nuts (12), lockwashers (11), screws (10), and mounting bracket (2) from instrument panel (1). Discard lockwashers (11).

### b. Installation

1. Install mounting bracket (2) to instrument panel (1) with two screws (10), new lockwashers (11), and nuts (12).
2. Install four wires (7), three screws (9), and new lockwashers (8) on switch (6).
3. Position keyway in switch down. Install locking ring (3), new lockwasher (4), and nut (5) on switch (6).

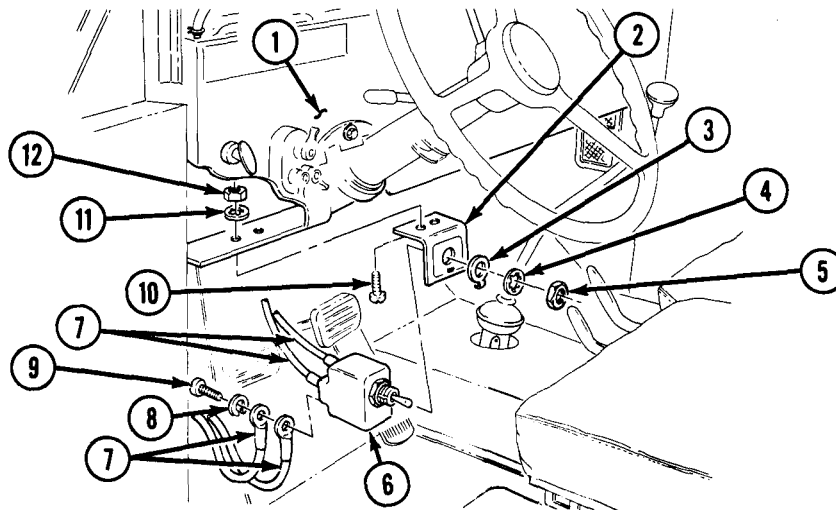

- FOLLOW-ON TASKS:
- Connect battery ground cable (para. 4-48).
  - Check heater switch for proper operation (TM 9-2320-361-10).

## 4-35. HOT WATER PERSONNEL HEATER BLOWER MOTOR RESISTOR REPLACEMENT

This task covers:

### a. Removal

### b. Installation

INITIAL SETUP:

#### APPLICABLE MODELS

All

#### MATERIALS/PARTS

Two lockwashers

#### REFERENCES (TM)

TM 9-2320-361-10

TM 9-2320-361-20P

#### EQUIPMENT CONDITION

- Parking brake set (TM 9-2320-361-10).
- Battery ground cable disconnected (para. 4-48).

### a. Removal

Remove two screws (4), lockwashers (3), and resistor (1) from firewall (2). Discard lockwashers (3).

### b. Installation

Install resistor (1) on firewall (2) with two new lockwashers (3) and screws (4).

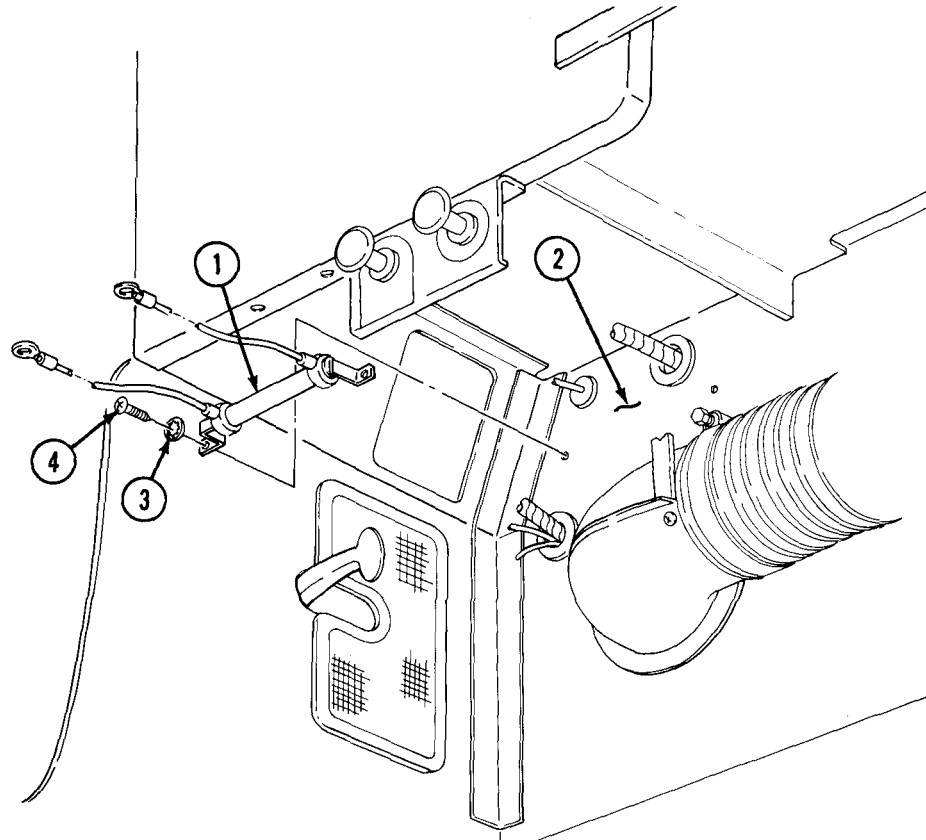

- FOLLOW-ON TASKS:
- Connect battery ground cable (para. 4-48).
  - Turn on hot water heater switch (TM 9-2320-361-10) and check personnel heater operations.



**4-36. FRONT-WHEEL DRIVE LOCK-IN SWITCH INDICATOR AND AIR PRESSURE SWITCH REPLACEMENT**

This task covers:

**a. Removal**

**b. Installation**

INITIAL SETUP:

APPLICABLE MODELS

All

REFERENCES (TM)

TM 9-2320-361-10

TM 9-2320-361-20P

EQUIPMENT CONDITION

- Parking brake set (TM 9-2320-361-10).
- Air reservoirs drained (TM 9-2320-361-10).
- Battery ground cable disconnected (para. 4-48).

**a. Removal**

**NOTE**

Tag all wires for installation.

1. Remove wire connector (10) from air pressure switch (9).
2. Remove air pressure switch (9) from air valve (8).
3. Disconnect wire (14) from connector (15) at front wiring harness (1).
4. Disconnect wires (11) and (12) from connector (13).
5. Disconnect wire (7) from indicator lamp socket (6).
6. Remove lens cover (4) and lamp (3) from indicator lamp socket (6).
7. Remove two screws (5) and indicator lamp socket (6) from bracket (2).

**b. Installation**

1. Install indicator lamp socket (6) on bracket (2) with two screws (5).
2. Install lamp (3) and lens cover (4) on indicator lamp socket (6).
3. Connect wire (7) to indicator lamp socket (6).
4. Connect wires (11) and (12) to connector (13).
5. Connect wire (14) to connector (15) at front wiring harness (1).
6. Install air pressure switch (9) on air valve (8).
7. Install wire connector (10) on air pressure switch (9).

### 4-36. FRONT-WHEEL DRIVE LOCK-IN SWITCH INDICATOR AND AIR PRESSURE SWITCH REPLACEMENT (Contd)

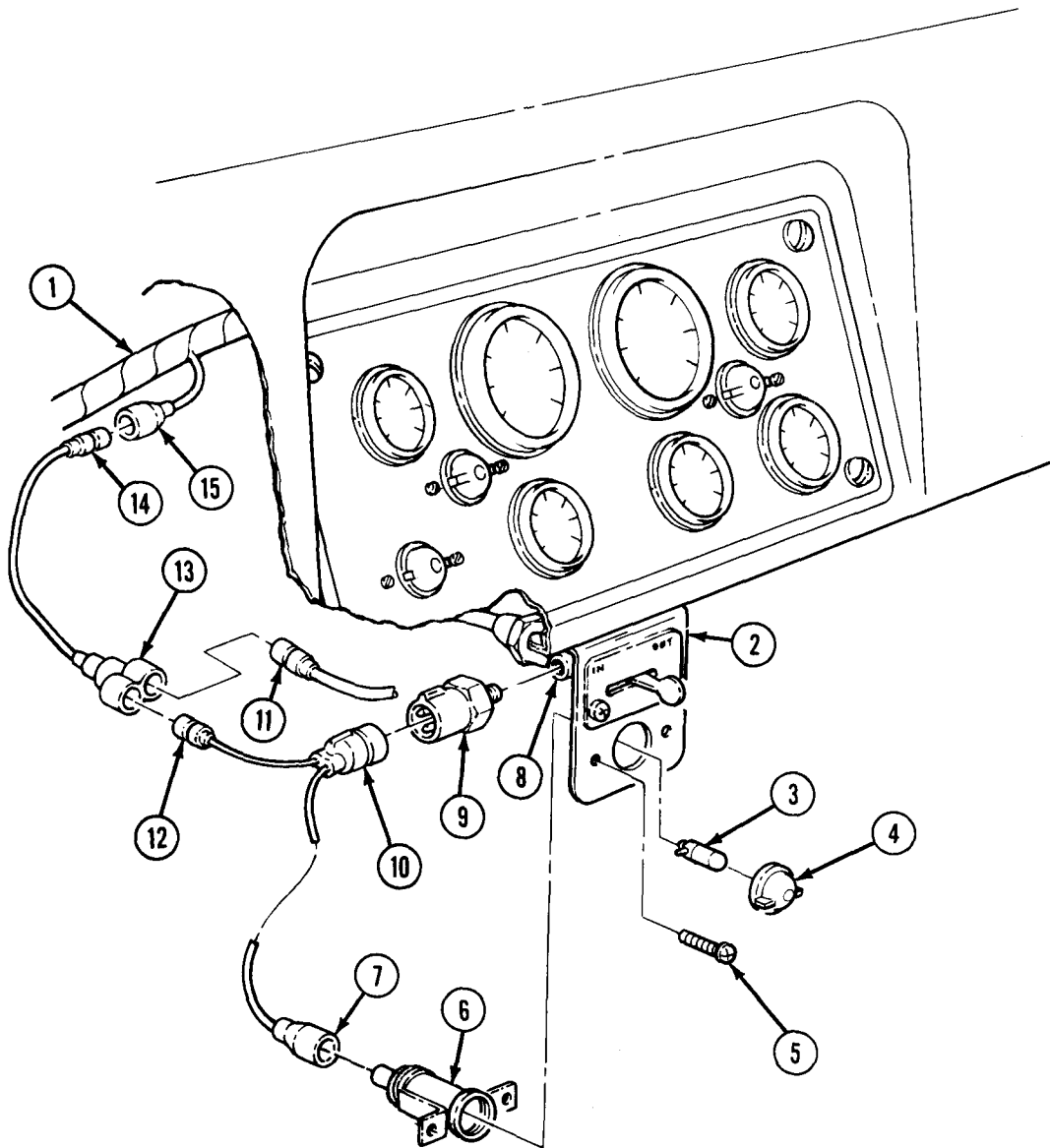

- FOLLOW-ON TASKS:
- Connect battery ground cable (para. 4-48).
  - Start engine (TM 9-2320-361-10) and allow air pressure to build up to normal operating range. Check for air leaks at switch.
  - Engage front-wheel drive lever (TM 9-2320-361-10) and check if indicator light is illuminated.

**4-37. FUEL PRESSURE SWITCH REPLACEMENT**

This task covers:

**a. Removal**

**b. Installation**

**INITIAL SETUP:**

APPLICABLE MODELS

All

MATERIALS/PARTS

Antiseize tape (Appendix C, Item 27)

REFERENCES (TM)

TM 9-2320-361-10

TM 9-2320-361-20P

EQUIPMENT CONDITION

- Parking brake set (TM 9-2320-361-10).
- Hood raised and secured (TM 9-2320-361-10).
- Battery ground cable disconnected (para. 4-48).

GENERAL SAFETY INSTRUCTIONS

Diesel fuel is flammable. Do not perform this task near open flames.

**WARNING**

Diesel fuel is flammable. Do not perform fuel system procedures near open flame. Injury or death to personnel may result.

**a. Removal**

**NOTE**

Tag wires for installation.

1. Disconnect wires (2) and (3) from fuel pressure switch (1).
2. Remove fuel pressure switch (1) and adapter (4) from tee (5).

**b. Installation**

**NOTE**

Clean all male pipe threads and wrap with antiseize tape before installation.

1. Install adapter (4) in tee (5).
2. Install fuel pressure switch (1) in adapter (4).
3. Connect wires (2) and (3) to fuel pressure switch (1).

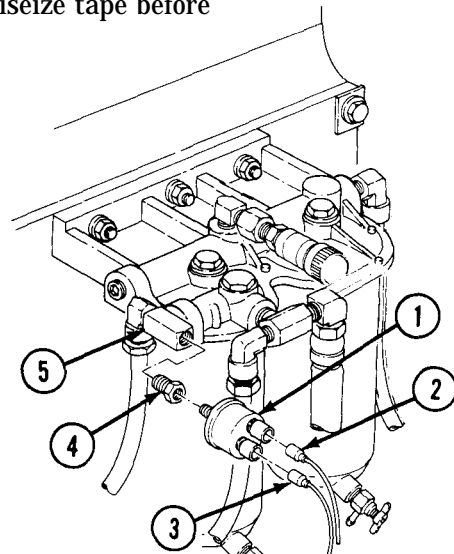

- FOLLOW-ON TASKS:**
- Connect battery ground cables (para. 4-48).
  - Start engine (TM 9-2320-361-10) to ensure switch is closed.

## Section IV. LIGHTING SYSTEM MAINTENANCE

**4-38. LIGHTING SYSTEM MAINTENANCE INDEX**

PARA. NO.	TITLE	PAGE NO.
4-39.	Sealed Beam and Headlamp Housing Maintenance	4-57
4-40.	Intermediate Turn Signal Replacement	4-61
4-41.	Front Composite Lamps, Housing, and Bracket Replacement	4-62
4-42.	Blackout Drive Lamp and Housing Replacement	4-64
4-43.	Floodlamp Housing and Mount Maintenance	4-66
4-44.	Floodlamp Replacement	4-68
4-45.	Side Marker and Clearance Lamps Replacement	4-69
4-46.	Rear Composite Lamps and Housing Replacement	4-70

**4-39. SEALED BEAM AND HEADLAMP HOUSING MAINTENANCE**

This task covers:

- |                                  |                             |
|----------------------------------|-----------------------------|
| a. Sealed Beam Removal           | d. Sealed Beam Installation |
| b. Headlamp Housing Removal      | e. Alinement                |
| c. Headlamp Housing Installation |                             |

APPLICABLE MODELS

All

MATERIALS/PARTS

Six lockwashers  
Chalk (Appendix C, Item 9)

REFERENCES (TM)

TM 9-2320-361-10  
TM 9-2320-361-20P

EQUIPMENT CONDITION

Parking brake set (TM 9-2320-361-10).  
Hood raised and secured (TM 9-2320-361-10).  
Battery ground cable disconnected (para. 4-48).

## 4-39. SEALED BEAM AND HEADLAMP HOUSING MAINTENANCE (Contd)

### a. Sealed Beam Removal

1. Remove three screws (1) and retaining ring (2) from headlamp housing (18).

#### NOTE

Tag all wires for installation.

2. Disconnect three wires (19) from connector plugs (13) and remove sealed beam (3).

### b. Headlamp Housing Removal

1. Disconnect three wires (12) from three connector plugs (13) at rear of housing (7).
2. Remove three nuts (10), lockwashers (9), shock mounts (8), and housing (7), from body (11). Discard lockwashers (9).
3. Loosen two adjusting screws (16) and remove spring (17) from headlamp housing (18).
4. Remove headlamp housing (18) from housing (7).
5. Remove two adjusting screws (16) and adjusting nuts (15) from housing (7).
6. Remove three nuts (4), lockwashers (5), washers (6), and shock mounts (8) from housing (7). Discard lockwashers (5).
7. Remove three connector plugs (13) and grommets (14) from housing (7).

### c. Headlamp Housing Installation

1. Install three grommets (14) and connectors (13) in housing (7).
2. Install three shock mounts (8) on housing (7) with three washers (6), new lockwashers (5), and nuts (4).
3. Install two adjusting screws (16) and adjusting nuts (15) in housing (7).

#### NOTE

Adjusting nuts must move freely for lamp adjustment. Do not bottom adjusting screws in step 4.

4. Install headlamp housing (18) on adjusting screws (16) and tighten adjusting screws (16) evenly.
5. Install spring (17) on housing (18) and adjusting screw (16).
6. Install housing (7) on body (11) with three shock mounts (8), new lockwashers (9), and nuts (10).
7. Connect three wires (12) to connector plugs (13).

### d. Sealed Beam Installation

1. Connect three wires (19) to connector plugs (13).
2. Install sealed beam (3) in headlamp housing (18) with retaining ring (2) and three retaining screws (1).

4-39. SEALED BEAM AND HEADLAMP HOUSING MAINTENANCE (Contd)

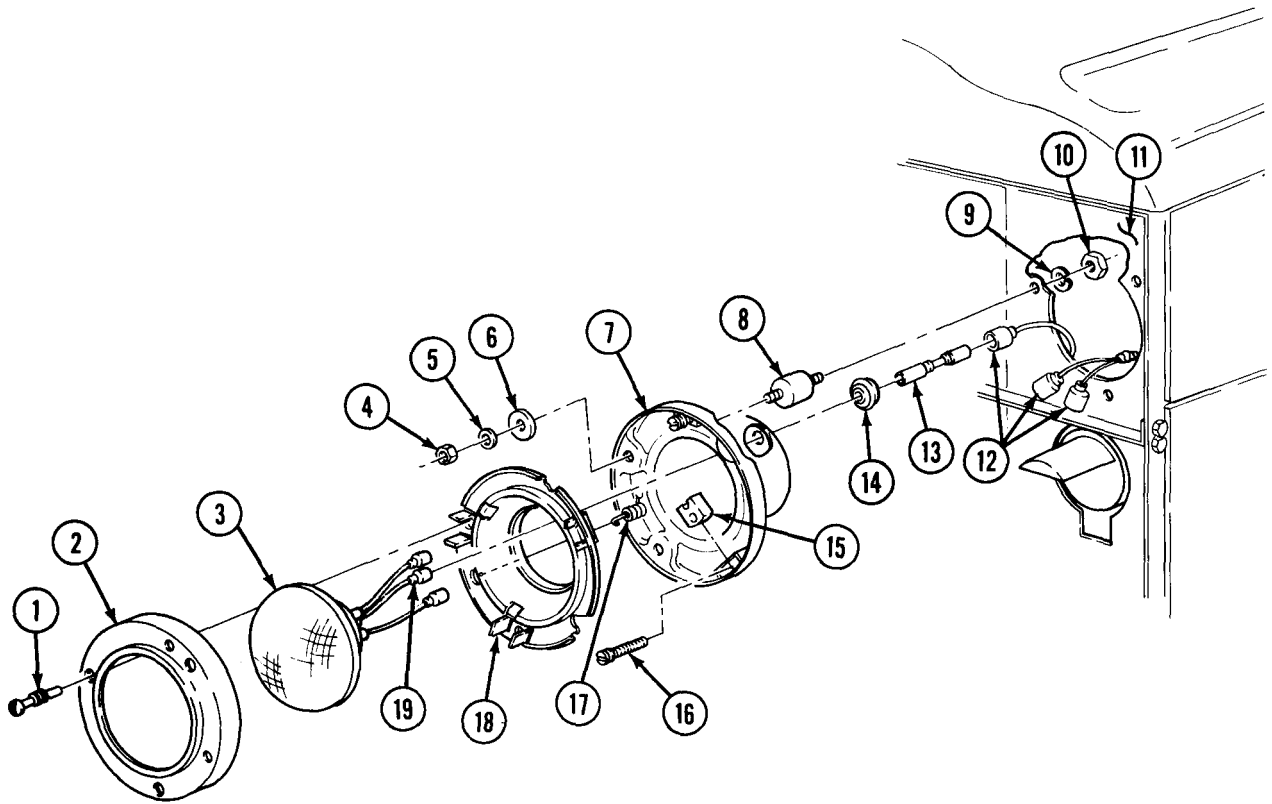

**4-39. SEALED BEAM AND HEADLAMP HOUSING MAINTENANCE (Contd)**

1. Using chalk, draw a horizontal line (3) on a wall the height of center of headlamp (6).
2. Park truck facing wall so headlamps (6) are 25 ft (7.62 m) from wall.
3. Using chalk, draw a vertical line (1) through horizontal line (3) so it is in line with center of headlamp (6).
4. Turn headlamps (6) on low beam (TM 9-2320-361-10).
5. Adjust headlamp (6) horizontal direction with adjusting screw (5) until left edge of bright light area (2) on wall is 2-6 in. (5.08-15.24 cm) right of vertical line (1).
6. Adjust headlamp (6) vertical direction with adjusting screw (4) until top edge of bright light area (2) on wall is touching lower side of horizontal line (3).
7. Adjust other headlamp (6) using same procedure.

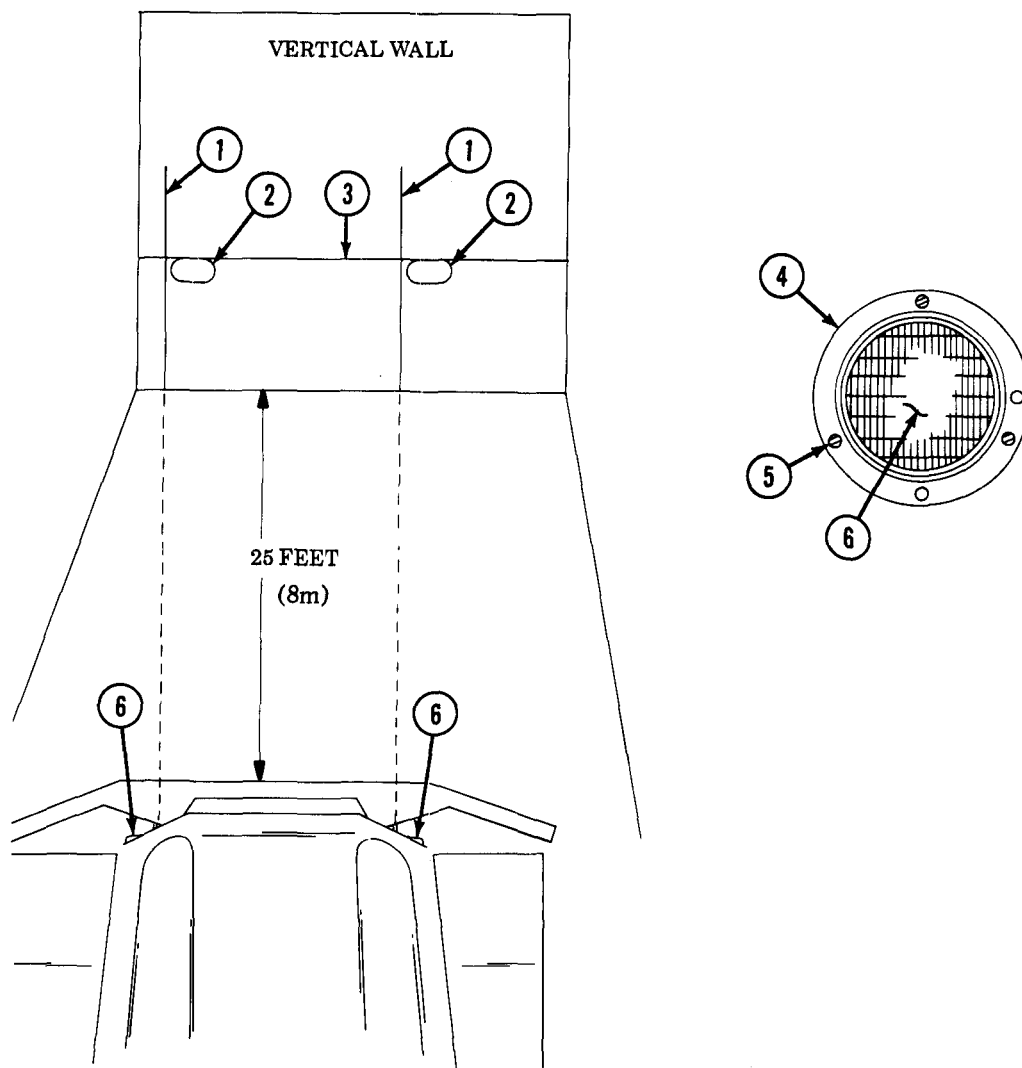

FOLLOW-ON TASK: Connect battery ground cable (para. 4-48).

## 4-40. INTERMEDIATE TURN SIGNAL REPLACEMENT

This task covers:

### a. Removal

### b. Installation

INITIAL SETUP:

#### APPLICABLE MODELS

All

#### MATERIALS/PARTS

Three lockwashers  
Two O-rings

#### REFERENCES (TM)

TM 9-2320-361-10

TM 9-2320-361-20P

#### EQUIPMENT CONDITION

- Parking brake set (TM 9-2320-361-10).
- Battery ground cable disconnected (para. 4-48).

### a. Removal

1. Remove amber lens (4), red lens (1), two O-rings (2), and lamp (3) from bracket (14). Discard O-rings (8).
2. Disconnect wire (13) from connector (12).
3. Remove nut (5), lockwasher (6), washer (15), and bracket (14) from brush guard (7). Discard lockwasher (6).
4. Remove two screws (11), lockwashers (10), nuts (9), and brush guard (7) from bracket (8). Discard lockwashers (10).

### b. Installation

1. Install brush guard (7) on bracket (8) with two screws (11), new lockwashers (10), and nuts (9).
2. Install bracket (14), washer (15), new lockwasher (6), and nut (5) on brush guard (7).
3. Connect wire (13) to connector (12).
4. Install lamp (3), two new O-rings (2), red lens (1), and amber lens (4) on bracket (14).

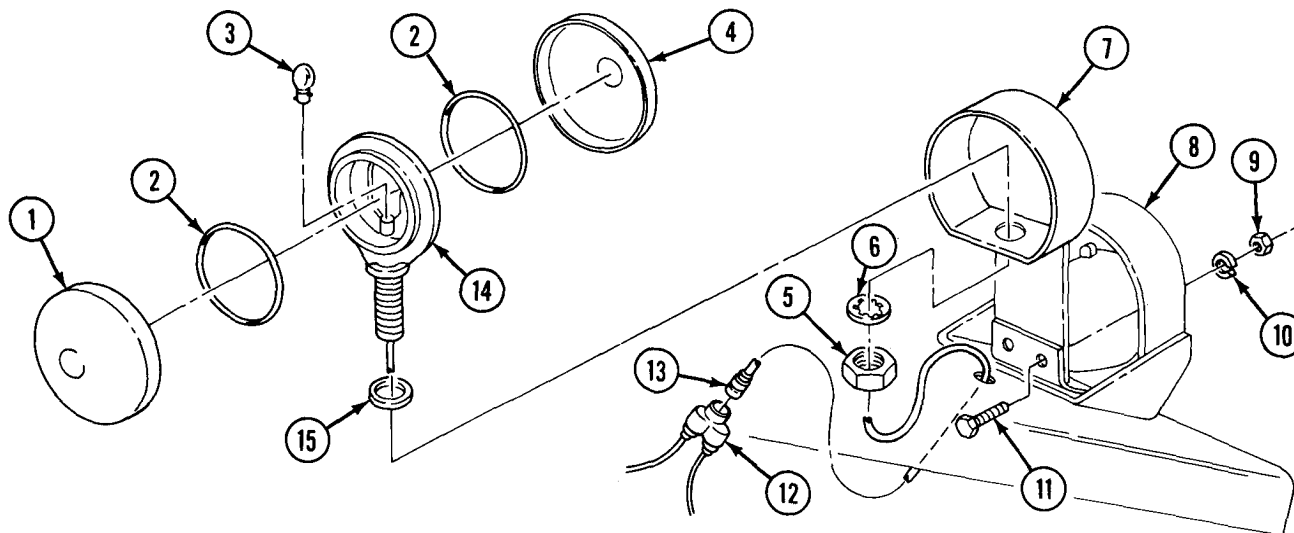

- FOLLOW-ON TASKS:
- Connect battery ground cable (para. 4-48).
  - Check operation of intermediate turn signal ight (TM 9-2320-361-10).



**4-41. FRONT COMPOSITE LAMPS, HOUSING, AND BRACKETE REPLACEMENT**

This task covers:

- a. Composite Lamps Removal
- b. Composite Light Housing Removal

- c. Composite Light Housing Installation
- d. Composite Lamps Installation

**INITIAL SETUP:**

APPLICABLE MODELS

All

MATERIALS/PARTS

Two lockwashers  
 Four locknuts  
 Gasket

REFERENCES (TM)

TM 9-2320-361-10  
 TM 9-2320-361-20P

EQUIPMENT CONDITION

- Parking brake set (TM 9-2320-361-10).
- Battery ground cable disconnected. (para. 4-48).
- Intermediate turn signal removed, if equipped (para. 4-40).

**a. Composite Lamps Removal**

1. Loosen five screws (2) and remove lens cover (1) and gasket (16) from composite light housing (4). Discard gasket (16).
2. Remove lamp(s) (3) from composite light housing (4).

**b. Composite Light Housing Removal**

**NOTE**

Tag all wires for installation.

1. Disconnect three wires (6) from wires (5).
2. Remove two screws (7), lockwashers (8), and composite light housing (4) from upper bracket (15). Discard lockwashers (8).
3. Remove four locknuts (13), screws (14), lower bracket (11), and upper bracket (15) from fender (10). Discard locknuts (13).
4. Remove two grommets (9) and (12) from fender (10) and lower bracket (11).

**c. Composite Light Housing Installation**

1. Install grommets (9) and (12) on fender (10) and lower bracket (11).
2. Install upper bracket (15) and lower bracket (11) on fender (10) with four screws (14) and new locknuts (13).
3. Install composite light housing (4) on upper bracket (15) with two new lockwashers (8) and screws (7).
4. Connect three wires (6) to three wires (5).

**d. Composite Lamps Installation**

1. Install lamp(s) (3) in composite light housing (4).
2. Install new gasket (16) and lens cover (1) and tighten five screws (2).

4-41. FRONT COMPOSITE LAMPS, HOUSING, AND BRACKET REPLACEMENT (Contd)

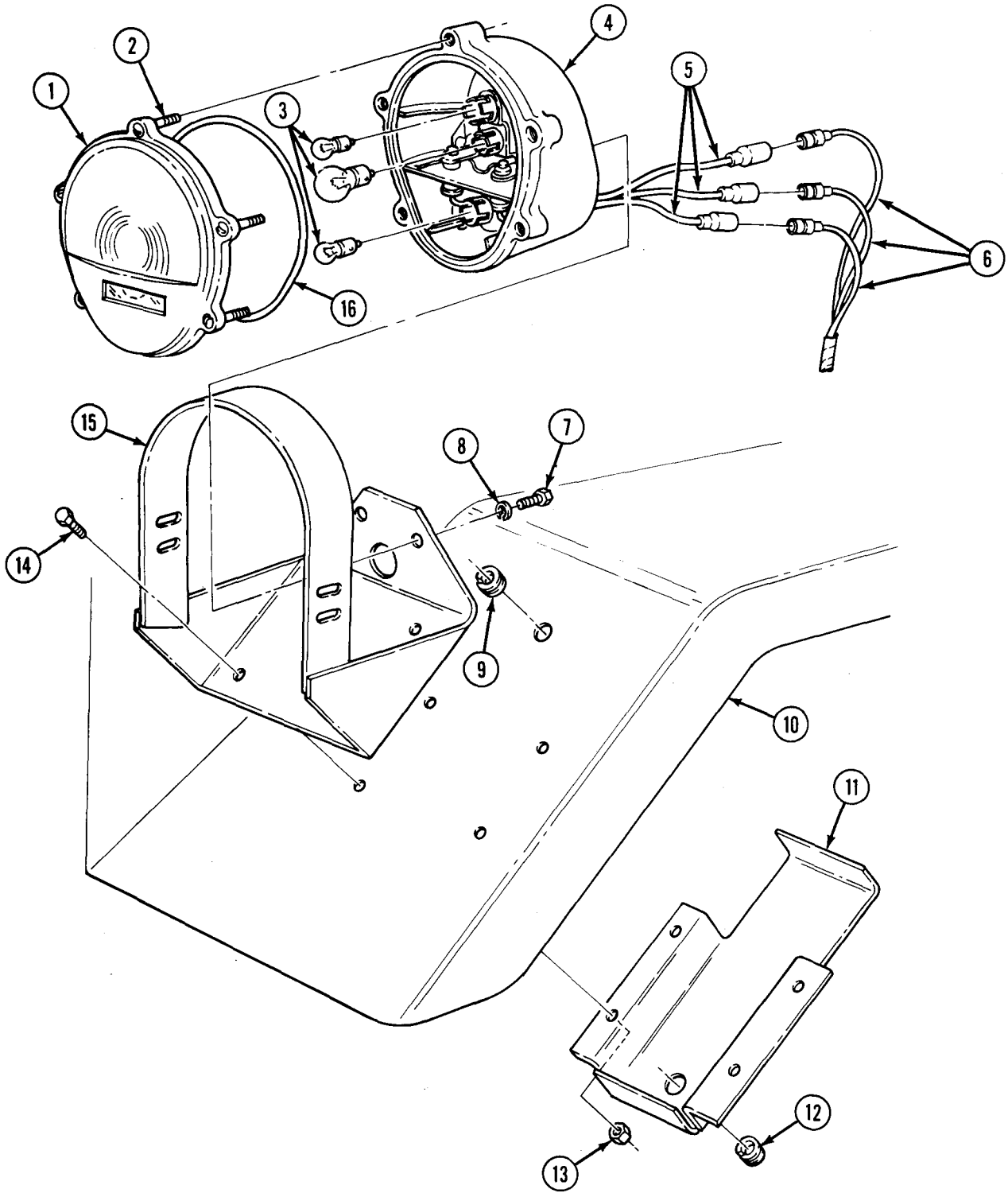

FOLLOW-ON TASKS: •Connect battery ground cable (para. 4-48).  
 •Check operation of front composite light (TM 9-2320-361-10).

**4-42. BLACKOUT DRIVE LAMP AND HOUSING REPLACEMENT**

This task covers:

- |   |   |
|---|---|
| <p><b>a. Blackout Drive Lamp Removal</b><br/> <b>b. Blackout Drive Lamp Housing Removal</b></p> | <p><b>c. Blackout Drive Lamp Housing Installation</b><br/> <b>d. Blackout Drive Lamp Installation</b></p> |
|---|---|

**INITIAL SETUP:**

APPLICABLE MODELS

All

MATERIALS/PARTS

Nine lockwashers  
 Three O-rings  
 Gasket

REFERENCES (TM)

TM 9-2320-361-10  
 TM 9-2320-361-20P

EQUIPMENT CONDITION

- Parking brake set (TM 9-2320-361-10).
- Hood raised and secured (TM 9-2320-361-10).
- Battery ground cable disconnected (para. 4-48).

**a. Blackout Drive Lamp Removal**

1. Loosen three screws (2) and remove lens cover (1), three O-rings (9), and gasket (8) from blackout drive lamp housing (4). Discard O-rings (9) and gasket (8).
2. Remove lamp (3) from blackout drive lamp housing (4).

**b. Blackout Drive Lamp Housing Removal**

**NOTE**

Tag all wires for installation.

1. Remove wire (5) from connector plug (6).
2. Remove nut (17), lockwasher (18), ground wire (16), mounting washers (19) and (7), and blackout drive lamp housing (4) from bracket (11). Discard lockwasher (18).
3. Remove eight nuts (14), seven lockwashers (15), lockwasher (13), clamp (12), bracket (11), and four shock mounts (10) from plate (20). Discard lockwashers (15) and (13).

**c. Blackout Drive Lamp Housing Installation**

1. Install four shock mounts (10) and bracket (11) on plate (20) with seven new lockwashers (15), clamp (12), new lockwasher (13), and eight nuts (14).
2. Install blackout drive lamp housing (4), mounting washers (19) and (7), ground wire (16), new lockwasher (18), and nut (17) to bracket (11).
3. Connect wire (5) to connector plug (6).

**d. Blackout Drive Lamp Installation**

1. Install lamp (3) in blackout drive lamp housing (4).
2. Install new gasket (8), three new O-rings (9), and lens cover (1) on blackout drive lamp housing (4) with three screws (2).

4-42. BLACKOUT DRIVE LAMP AND HOUSING REPLACEMENT (Contd)

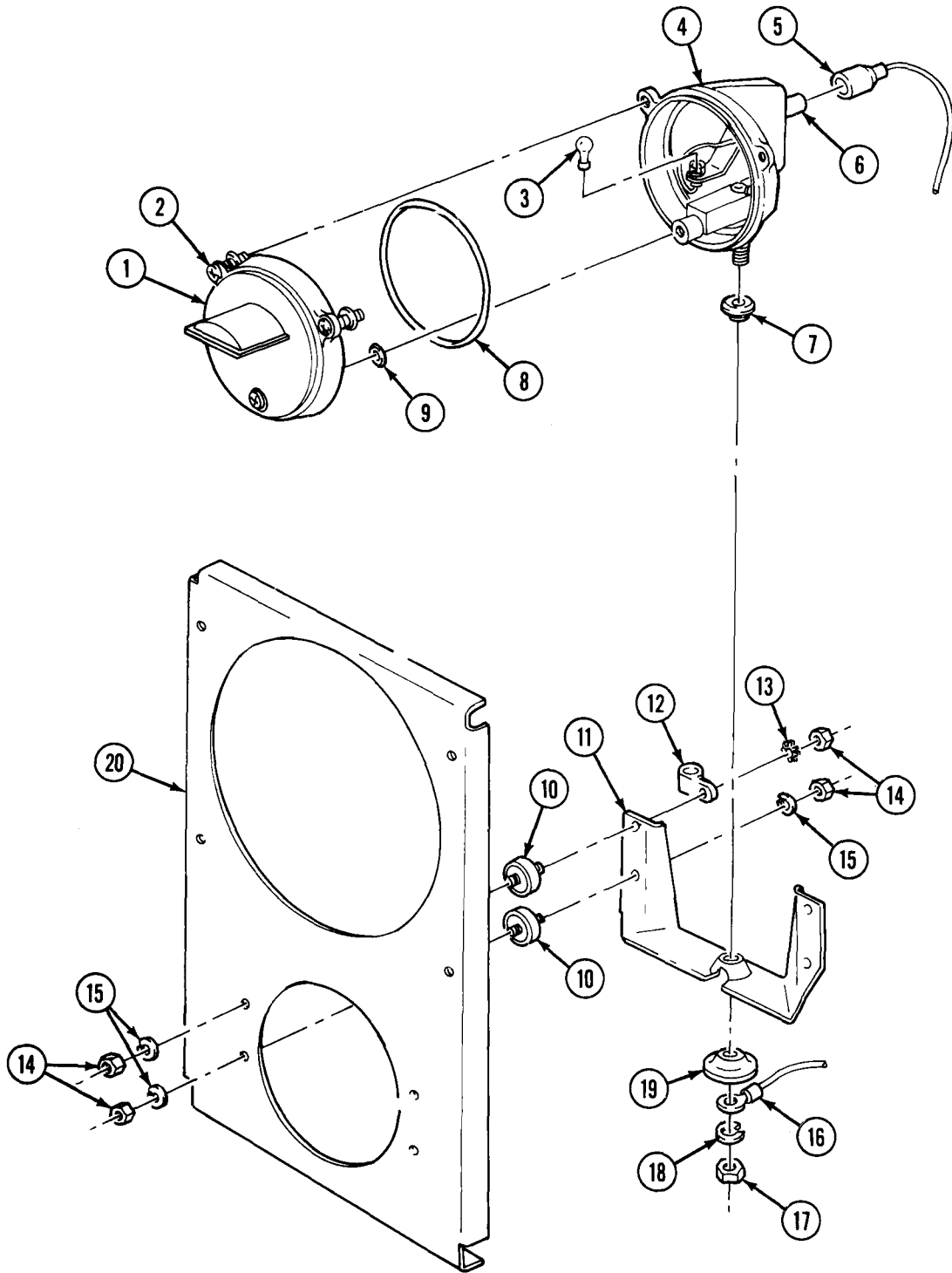

- FOLLOW-ON TASKS:
- Connect battery ground cable (para. 4-48).
  - Check operation of blackout drive lamp (TM 9-2320-361-10)

**4-43. FLOODLAMP HOUSING AND MOUNT MAINTENANCE**

This task covers:

- |  |  |
|--|--|
| <ul style="list-style-type: none"> <li>a. Floodlamp Housing and Mount Removal</li> <li>b. Floodlamp Housing and Mount Disassembly</li> </ul> | <ul style="list-style-type: none"> <li>c. Floodlamp Housing and Mount Assembly</li> <li>d. Floodlamp Housing and Mount Installation</li> </ul> |
|--|--|

INITIAL SETUP:

APPLICABLE MODELS  
M756A2

MATERIALS/PARTS  
Four lockwashers

REFERENCES (TM)  
TM 9-2320-361-10  
TM 9-2320-361-20P

EQUIPMENT CONDITION  

- Parking brake set (TM 9-2320-361-10).
- Battery ground cable disconnected (para. 4-48).
- Floodlamp removed (para. 4-44).

**a. Floodlamp Housing and Mount Removal**

**NOTE**

Tag all wires for installation.

1. Disconnect two wires (11) from connectors (1).
2. Remove handle (6) from cab protector (10) and remove floodlamp housing (2) and floodlamp housing mount (5).

**b. Floodlamp Housing and Mount Disassembly**

1. Remove two nuts (7) and (8), washer (9), floodlamp housing bracket (3), and washer (4) from floodlamp housing mount (5).
2. Remove two nuts (13), lockwashers (14), and washers (15) from screws (30). Discard lockwashers (14).
3. Remove two screws (30), washers (29), four spring washers (28), two washers (27), floodlamp housing bracket (3), two washers (26), spacers (20), and grommet (19) from floodlamp housing (2).
4. Disconnect wires (12) and (22) from two connectors (1).
5. Remove two screws (17), lockwashers (18), and switch (23) from floodlamp housing (2). Discard lockwashers (18).
6. Remove two screws (25), retainer (24), and switch top (23) from bottom of switch (21).
7. Remove two connectors (1) and grommets (16) from floodlamp housing (2).

**c. Floodlamp Housing and Mount Assembly**

1. Install two grommets (16) and connectors (1) in floodlamp housing (2).
2. Install switch top (23), retainer (24), and two screws (25) in switch bottom (21).
3. Install switch (21), two new lockwashers (18), and screws (17) in floodlamp housing (2).
4. Connect two wires (12) and (22) to connectors (1).
5. Install two grommets (19) and spacers (20) on floodlamp housing (2).
6. Position floodlamp housing (2) and two washers (26) on floodlamp housing bracket (3) and install with two washers (27), four spring washers (28), two washers (29), and screws (30).
7. Install two washers (15), new lockwashers (14), and nuts (13) to screws (30).
8. Install washer (4) with floodlamp housing bracket (3), washer (9), and two nuts (8) and (7) to floodlamp housing mount (5).

**4-43. FLOODLAMP HOUSING AND MOUNT MAINTENANCE (Contd)**

**d. Floodlamp Housing and Mount Installation**

1. Install floodlamp housing (2) and floodlamp housing mount (5) to cab protector (10) with handle (6).
2. Connect two wires (11) to connectors (1).

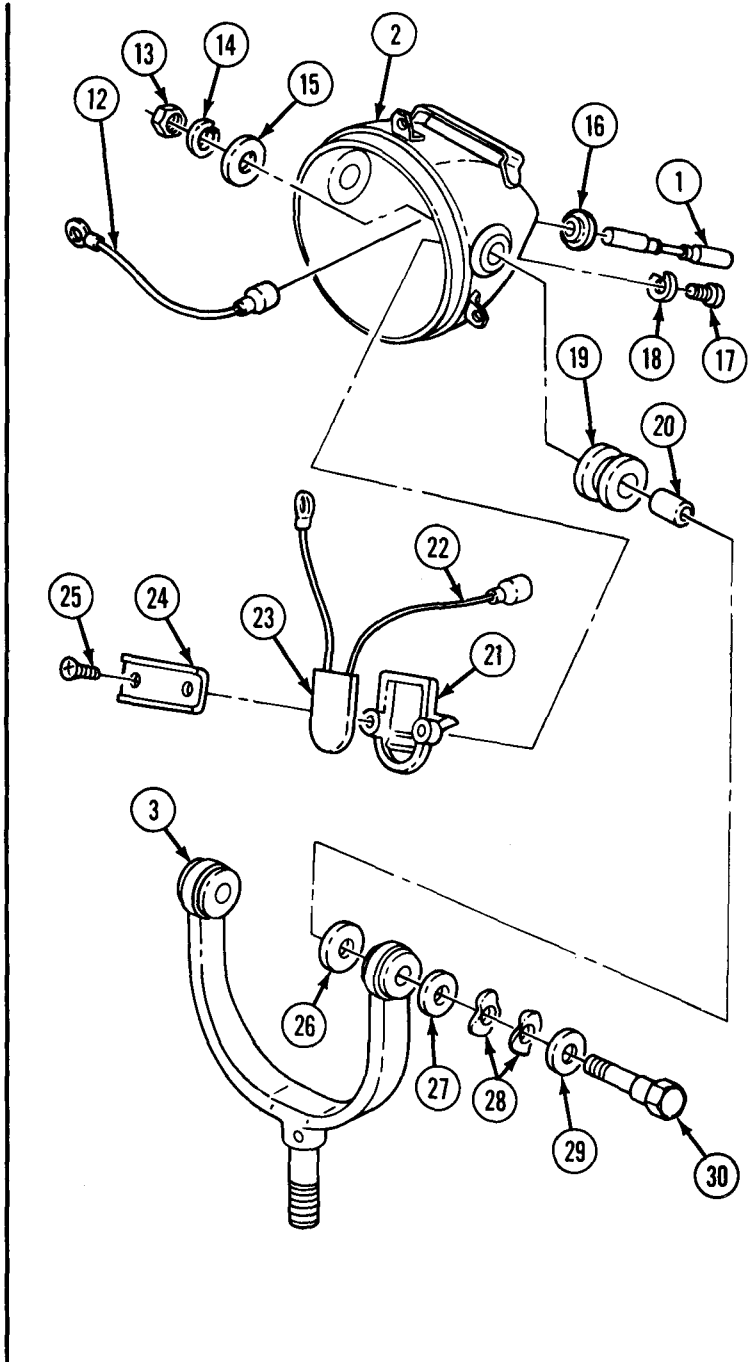
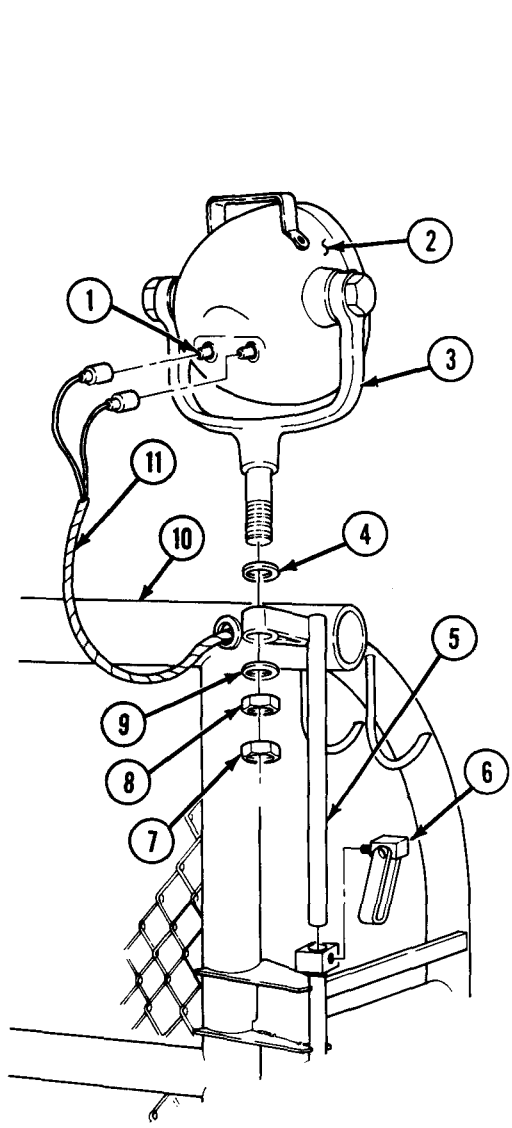

- FOLLOW-ON TASKS:**
- Install floodlamp (para. 4-44).
  - Connect battery ground cable (para. 4-48).
  - Check operation of floodlamp (TM 9-2320-361-10).

**4-44. FLOODLAMP REPLACEMENT**

This task covers:

**a. Floodlamp Removal**

**b. Floodlamp Installation**

INITIAL SETUP:

APPLICABLE MODELS

M756A2

MATERIALS/PARTS

Two lockwashers

Three O-rings

REFERENCES (TM)

TM 9-2320-361-10

TM 9-2320-361-20P

EQUIPMENT CONDITION

- Parking brake set (TM 9-2320-361-10).
- Battery ground cable disconnected (para. 4-48).
- Floodlamp housing removed (para. 4-43).

**a. Floodlamp Removal**

1. Loosen three screws (1) and remove lamp door (2) and three O-rings (3) from floodlamp housing (9). Discard O-rings (3).

**NOTE**

Tag all wires for installation.

2. Remove two screws (8), lockwashers (7), and wires (5) and (6) from lamp (4). Discard lockwashers (7).
3. Remove four springs (10) and lamp (4) from lamp door (2).

**b. Floodlamp Installation**

1. Install lamp (4) on lamp door (2) with four springs (10).
2. Install wires (5) and (6) on lamp (4) with two new lockwashers (7) and screws (8).
3. Install three new O-rings (3) and lamp door (2) on floodlamp housing (9), and tighten three screws (1).

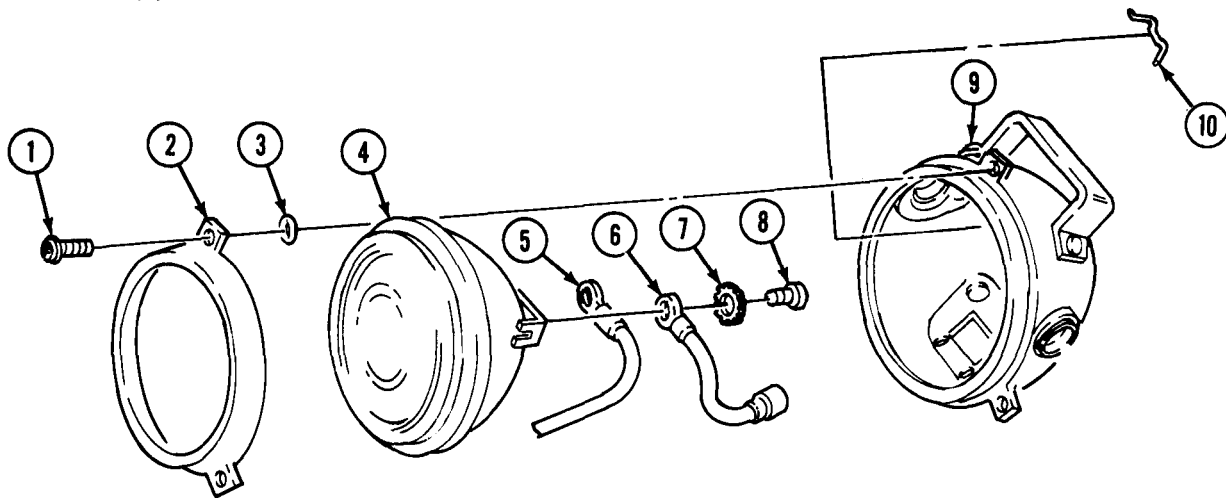

- FOLLOW-ON TASKS:
- Connect battery ground cable (para. 4-48).
  - Check operation of floodlamp (TM 9-2320-361-10).

## 4-45. SIDE MARKER AND CLEARANCE LAMPS REPLACEMENT

This task covers:

### a. Removal

### b. Installation

INITIAL SETUP:

#### APPLICABLE MODELS

All

#### MATERIALS/PARTS

Six lockwashers  
Locknut

#### REFERENCES (TM)

TM 9-2320-361-10  
TM 9-2320-361-20P

#### EQUIPMENT CONDITION

Parking brake set (TM 9-2320-361-10).  
Battery ground cable disconnected (para. 4-48).

### a. Removal

#### NOTE

All side marker lights and clearance lights are replaced the same.

1. Remove two screws (11), lens frame (10), and lens (9) from marker light base (6).
2. Remove lamp (8) from marker light base (6).
3. Remove four nuts (3), lockwashers (4), and screws (7) from marker light base (6) and bracket (5). Discard lockwashers (4).
4. Disconnect wire (2) from wire (1) and remove marker light base (6) from bracket (5).
5. Remove locknut (13), two lockwashers (14), screw (15), and bracket (5) from fender (12). Discard lockwashers (14) and locknut (13).

### b. Installation

1. Install bracket (5) on fender (12) with screw (15), two new lockwashers (14), and new locknut (13).
2. Connect wire (2) to wire (1).
3. Install marker light base (6) on bracket (5) with four screws (7), new lockwashers (4), and nuts (3).
4. Install lamp (8) in marker light base (6).
5. Install lens (9) and lens frame (10) on marker light base (6) with two screws (11).

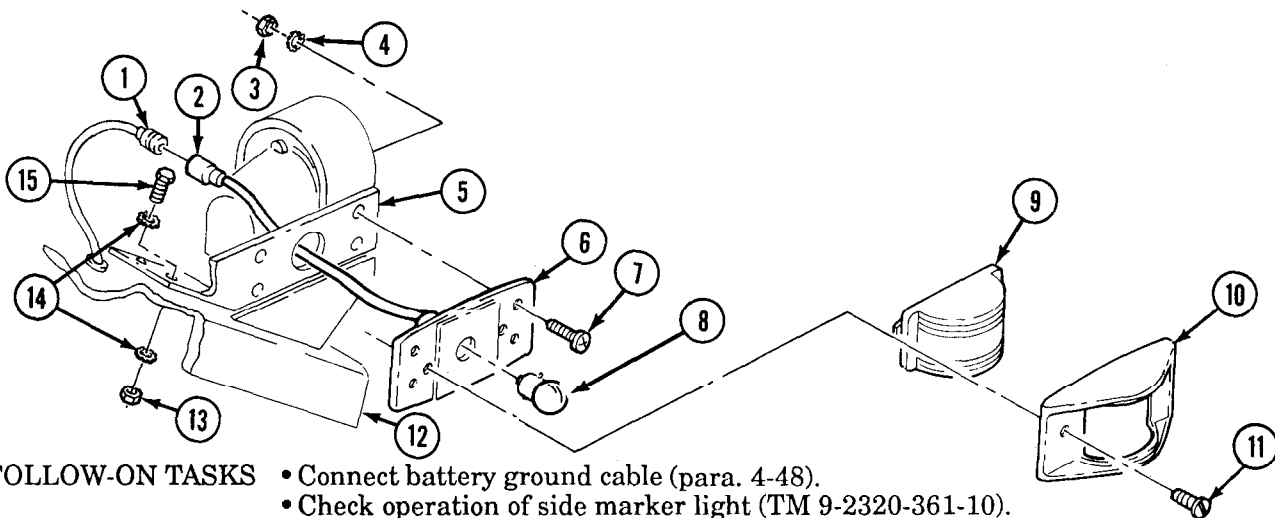

- FOLLOW-ON TASKS**
- Connect battery ground cable (para. 4-48).
  - Check operation of side marker light (TM 9-2320-361-10).



## 4-46. REAR COMPOSITE LAMPS AND HOUSING REPLACEMENT

This task covers:

- |   |  |
|---|--|
| a. Rear Composite Lamps Removal         | c. Rear Composite Lamps Housing Installation |
| b. Rear Composite Lamps Housing Removal | d. Rear Composite Lamps Installation         |

### INITIAL SETUP:

#### APPLICABLE MODELS

All

#### MATERIALS/PARTS

Two lockwashers

Gasket

#### REFERENCES (TM)

TM 9-2320-361-10

TM 9-2320-361-20P

#### EQUIPMENT CONDITION

- Parking brake set (TM 9-2320-361-10).
- Battery ground cable disconnected (para. 4-48).

### a. Rear Composite Lamps Removal

1. Loosen six screws (8) and remove lens (9) and gasket (7) from composite lamp housing (5). Discard gasket (7).
2. Remove lamp(s) (6) from composite lamp housing (5).

### b. Rear Composite Lamps Housing Removal

#### NOTE

Tag all wires for installation.

1. Disconnect four wires (10) from wires (4).
2. Remove two screws (1), lockwashers (2), and composite lamp housing (5) from bracket (3). Discard lockwashers (2).

### c. Rear Composite Lamps Housing Installation

1. Install composite lamp housing (5) on bracket (3) with two new lockwashers (2) and screws (1).
2. Connect four wires (10) to wires (4).

### d. Rear Composite Lamps Installation

1. Install lamp(s) (6) in composite lamp housing (5).
2. Install new gasket (7) and lens (9) on composite lamp housing (5) with six screws (8).

4-46. REAR COMPOSITE LAMPS AND HOUSING REPLACEMENT (Contd)

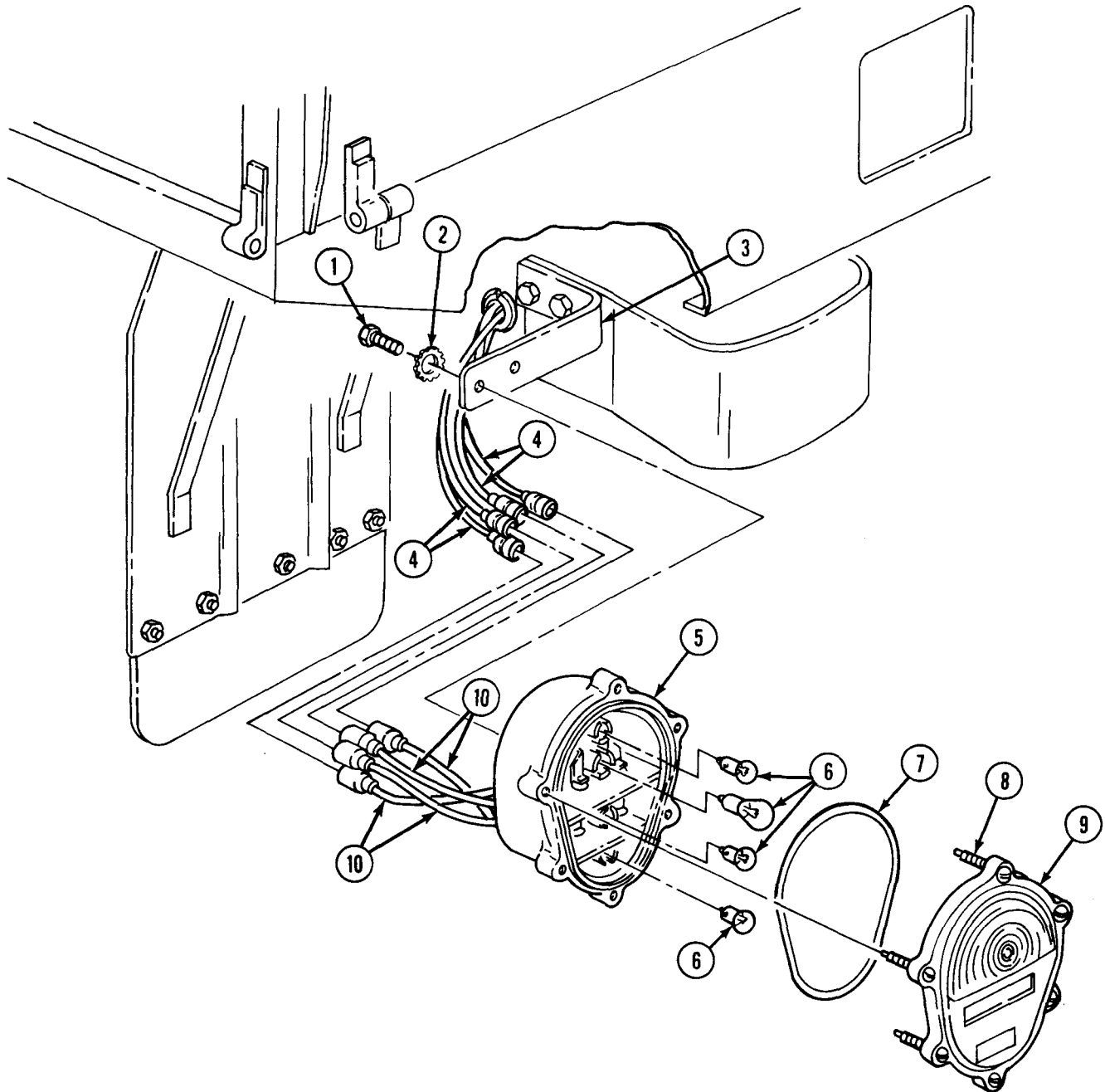

- FOLLOW-ON TASKS:
- Connect battery ground cable (para. 4-48).
  - Check operation of rear composite lamps (TM 9-2320-361-10).

Section V. BATTERY AND BATTERY BOX MAINTENANCE

**4-47. BATTERY AND BATTERY BOX MAINTENANCE INDEX**

PARA. NO.	TITLE	PAGE NO.
4-48.	Battery Cables and Clamps Replacement	4-72
4-49.	Battery and Battery Box Replacement and Servicing	4-76

**4-48. BATTERY CABLES AND CLAMPS REPLACEMENT**

**This task covers:**

- |  |   |
|--|---|
| <ul style="list-style-type: none"> <li>a. Ground Cable Disconnection</li> <li>b. Ground Cable Connection</li> <li>c. Ground Cable Removal</li> <li>d. Battery-to-Battery Cable Removal</li> <li>e. Positive Cable Removal</li> </ul> | <ul style="list-style-type: none"> <li>f. Battery Clamps Removal</li> <li>g. Battery Clamps Installation</li> <li>h. Positive Cable Installation</li> <li>i. Battery-to-Battery Cable Installation</li> <li>j. Ground Cable Installation</li> </ul> |
|--|---|

**INITIAL SETUP:**

APPLICABLE MODELS

All

MATERIALS/PARTS

Two lockwashers  
GAA grease (Appendix C, Item 13)

REFERENCES (TM)

TM 9-2320-361-10  
TM 9-2320-361-20P  
TM 9-6140-200-14

EQUIPMENT CONDITION

Parking brake set (TM 9-2320-361-10).

GENERAL SAFETY INSTRUCTIONS

- Wear safety goggles and rubber gloves.
- Do not smoke when performing battery maintenance.
- Remove all jewelry.
- When removing battery cables, disconnect ground cable first.

**WARNING**

- Battery acid (electrolyte) is extremely harmful. Always wear safety goggles and rubber gloves when performing battery maintenance. Severe injury will result if acid contacts eyes or skin.
- Do not smoke, have open flame, or make sparks when performing battery maintenance. Batteries may explode causing severe injury to personnel.
- Remove all jewelry such as rings, dog tags, bracelets, etc. If jewelry or disconnected battery ground cable contacts positive battery post, a direct short can result, causing damage to equipment, or severe injury to personnel.
- When removing battery cables, disconnect ground cable first. Do not allow tools to come in contact with vehicle when disconnecting cable clamps. A direct short can result, causing instant heating of tools, tool damage, battery damage, or battery explosion, and severe injury to personnel.

## 4-48. BATTERY CABLES AND CLAMPS REPLACEMENT (Contd)

### **CAUTION**

- During installation of battery terminals, make sure positive clamps are installed on positive posts (+) and negative clamps are installed on negative (-) posts. Failure to connect clamps to correct posts will reverse polarity of circuitry and may cause damage to rectifier diodes in alternator, vehicle wiring, and radios (if equipped).
- Do not use a hammer during installation of battery terminal. Spread battery terminal open, or damage to equipment may result.

### **NOTE**

- For general cleaning instructions, maintenance, and servicing of battery cables and clamps, refer to TM 9-6140-200-14.
- Apply a light coat of GAA grease to all battery terminals after installation. Wipe off excess grease.

#### **a. Ground Cable Disconnection**

1. Open battery compartment door (7).
2. Loosen two thumbscrews (8) and clamps (11), and pull battery box (10) onto running board (9).
3. Remove nut (2), screw (4), and disconnect ground cable (1) from battery clamp (6).
4. Remove nut (3), screw (5), and clamp (6) from negative post (12).

#### **b. Ground Cable Connection**

1. Install clamp (6) on negative post (12) with screw (5) and nut (3).
2. Install ground cable (1) on battery clamp (6) with screw (4) and nut (2).

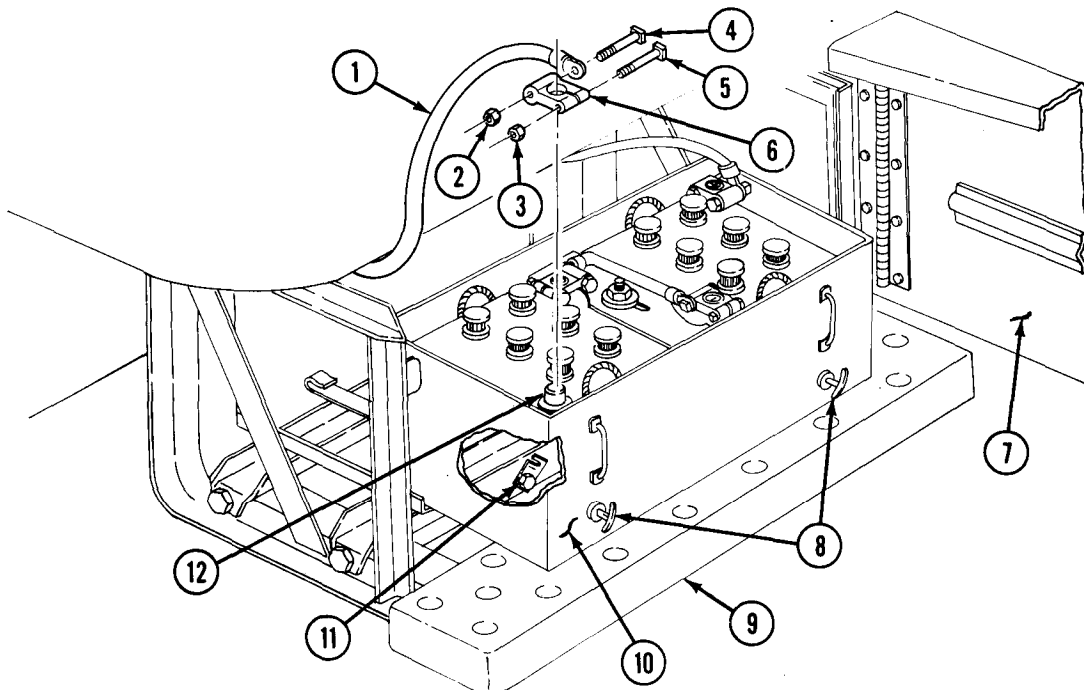

## 4-48. BATTERY CABLES AND CLAMPS REPLACEMENT (Contd)

### c. Ground Cable Removal

1. Remove nut (24), screw (34), and disconnect ground cable (26) from battery clamp (25).
2. Remove nut (18), lockwasher (19), ground cable (26), lockwasher (22), and screw (21) from frame (20). Discard lockwashers (19) and (22).

### d. Battery-to-Battery Cable Removal

1. Remove nut (30), screw (2), and cable (1) from negative clamp (4).
2. Remove nut (32), screw (29), and cable (1) from positive clamp (27).

### e. Positive Cable Removal

1. Remove nut (7), screw (10), and disconnect positive cable (5) from battery clamp (6).

#### NOTE

Remove two wires from starter solenoid on M756A2 model.

2. Remove nut (40) and disconnect positive cable (5) and wire (39) from starter solenoid (38).
3. Remove screw (36), clamp (37), and positive cable (5) from frame (20).

### f. Battery Clamps Removal

1. Remove two nuts (31) and (23), screws (3) and (35), and clamps (4) and (25) from two negative posts (15).
2. Remove two nuts (8) and (33), screws (11) and (28), and clamps (6) and (27) from two positive posts (12).

### g. Battery Clamps Installation

1. Install two clamps (6) and (27) on two positive posts (12) with two screws (11) and (28) and nuts (8) and (33).
2. Install two clamps (4) and (25) on two negative posts (15) with two screws (3) and (35) and nuts (31) and (23).

### h. Positive Cable Installation

1. Install clamp (37) and positive cable (5) on frame (20) with screw (36).

#### NOTE

Install two wires on starter solenoid for M756A2 model.

2. Connect wire (39) and positive cable (5) to starter solenoid (38) with nut (40).
3. Connect positive cable (5) to clamp (6) with screw (10) and nut (7).

### i. Battery-to-Battery Cable Installation

1. Install cable (1) on positive clamp (27) with screw (29) and nut (32).
2. Install cable (1) on negative clamp (4) with screw (2) and nut (30).

### j. Ground Cable Installation

1. Connect ground cable (26) to frame (20) with new lockwasher (22), screw (21), lockwasher (19), and nut (18).
2. Connect ground cable (26) to battery clamp (25) with screw (34) and nut (24).
3. Push battery box (13) into battery compartment (17) and install with two clamps (16) and thumbscrews (14).
4. Close battery compartment door (9).

4-48. BATTERY CABLES AND CLAMPS REPLACEMENT (Contd)

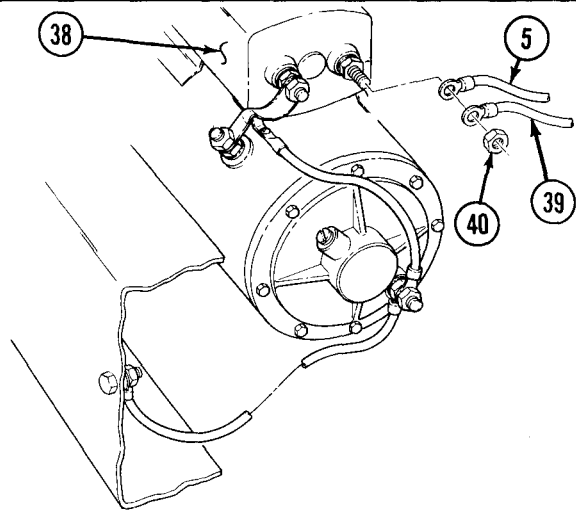
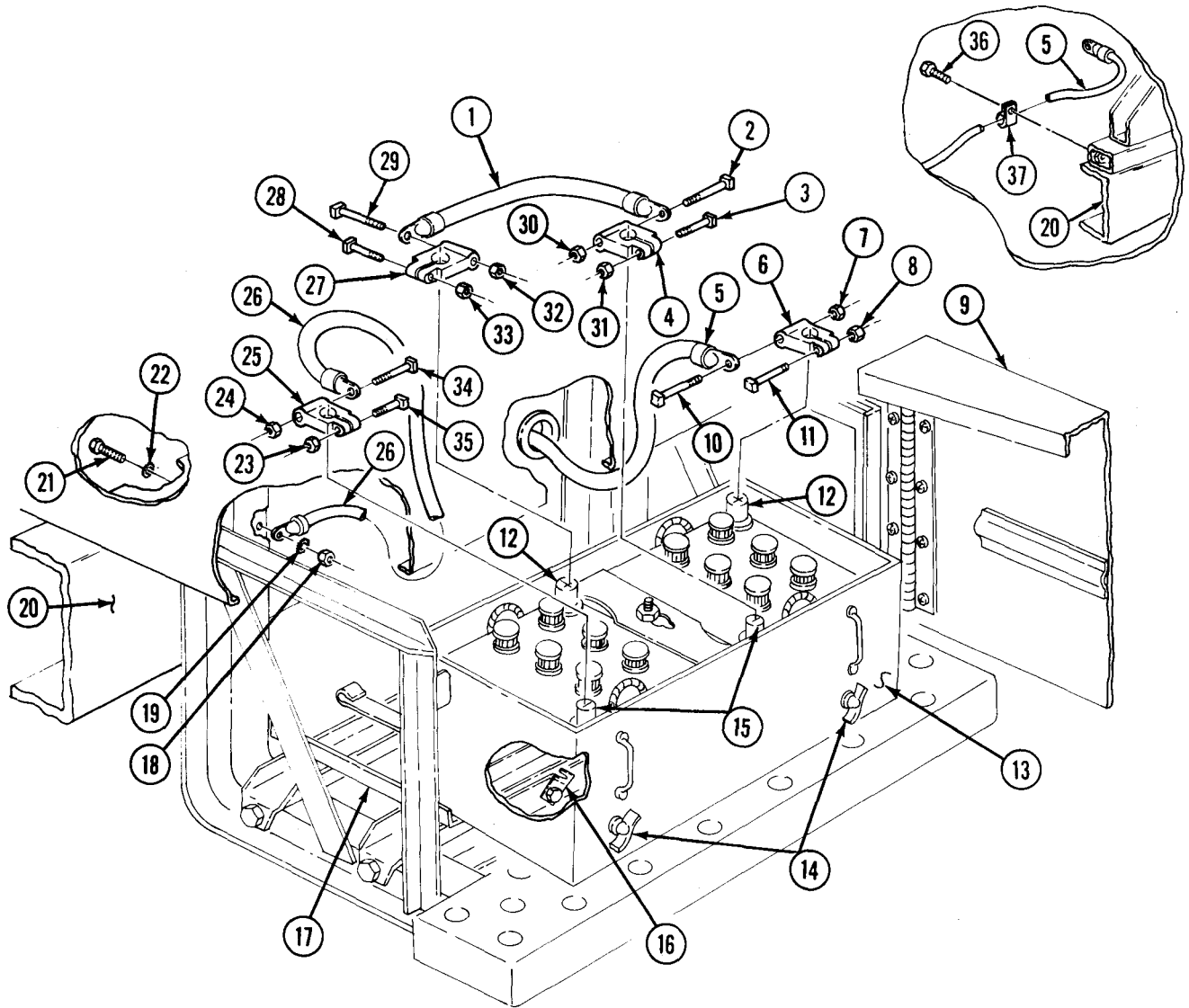

## 4-49. BATTERY AND BATTERY BOX REPLACEMENT AND SERVICING

This task covers:

- |  |  |
|--|--|
| <ul style="list-style-type: none"> <li>a. Batteries and Battery Box Removal</li> <li>b. Battery Box Support Removal</li> <li>c. Battery and Battery Box Servicing</li> </ul> | <ul style="list-style-type: none"> <li>d. Battery Box Support Installation</li> <li>e. Batteries and Battery Box Installation</li> </ul> |
|--|--|

### INITIAL SETUP:

#### APPLICABLE MODELS

All

#### MATERIALS/PARTS

Eleven locknuts  
Four lockwashers  
Two spring washers

#### PERSONNEL REQUIRED

Two

#### REFERENCES (TM)

TM 9-2320-361-10  
TM 9-2320-361-20P  
TM 9-6140-200-14

#### EQUIPMENT CONDITION

- Parking brake set (TM 9-2320-361-10).
- Battery clamps removed (para. 4-48).

#### GENERAL SAFETY INSTRUCTIONS

- Wear safety goggles and rubber gloves.
- Do not smoke when performing battery maintenance.
- Remove all jewelry.
- When removing batteries, disconnect battery ground cable first.

### WARNING

- Battery acid (electrolyte) is extremely harmful. Always wear safety goggles and rubber gloves when performing battery maintenance. Severe injury will result if acid contacts eyes or skin.
- Do not smoke, have open flame, or make sparks when performing battery maintenance. Batteries may explode causing severe injury to personnel.
- Remove all jewelry such as rings, dog tags, bracelets, etc. If jewelry or disconnected battery ground cable contacts positive battery post, a direct short can result, causing damage to equipment or severe injury to personnel.
- When removing battery cables, disconnect ground cable first. Do not allow tools to come in contact with vehicle when disconnecting cable clamps. A direct short can result, causing instant heating of tools, tool damage, battery damage, or battery explosion, and severe injury to personnel.

#### a. Batteries and Battery Box Removal

1. Remove four nuts (1), lockwashers (2), J-bolts (4), and battery holddown (3) from battery box (6) and two batteries (5). Discard lockwashers (2).

#### **NOTE**

Assistant will help with step 2.

2. Remove two batteries (5) from battery box (6).
3. Remove battery box (6) from battery box support (7).
4. Remove five locknuts (20), screws (18), and shield (19) from battery box (6). Discard locknuts (20).
5. Remove two nuts (8), thumb screws (10), and washers (9) from battery box (6).

#### b. Battery Box Support Removal

1. Remove four locknuts (16), screws (17), and battery box support (7) from two running board brackets (15). Discard locknuts (16).
2. Remove two locknuts (11), screws (14), spring washers (13), and clamps (12) from battery box support (7). Discard locknuts (11) and spring washers (13).

4-49. BATTERY AND BATTERY BOX REPLACEMENT AND SERVICING (Contd)

c. Battery and Battery Box Servicing

For battery and battery box servicing instructions refer to TM 9-6140-200-14.

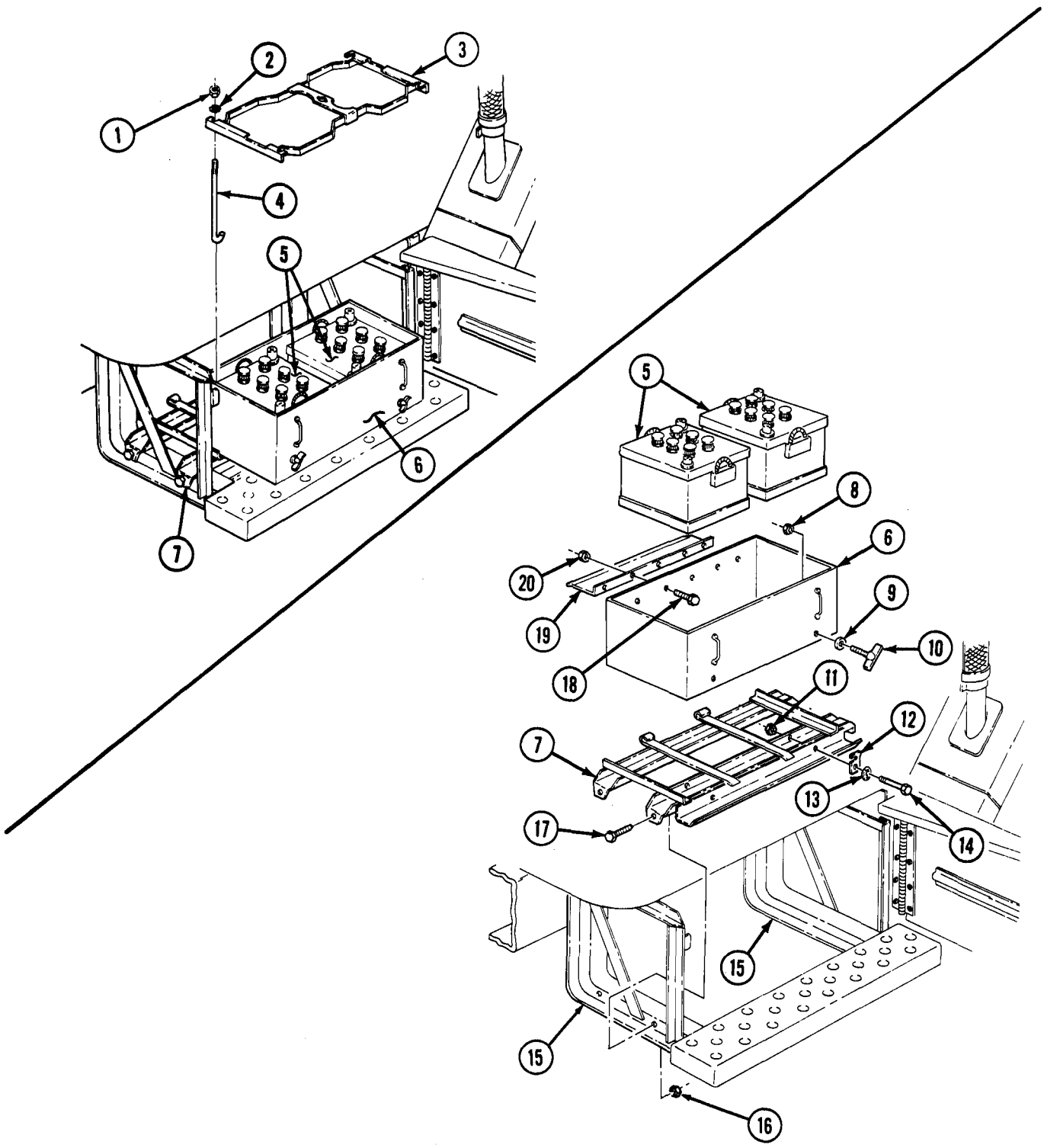



**4-49. BATTERY AND BATTERY BOX REPLACEMENT AND SERVICING (Contd)**

**d. Battery Box Support Installation**

**NOTE**

Ensure clamps move freely when nuts are installed.

1. Install two clamps (12) on battery box support (7) with two new spring washers (13), screws (14), and new locknuts (11). Tighten nuts (11) so that clamps (12) may move freely.
2. Install battery box support (7) on two running board brackets (15) with four screws (17) and new locknuts (16).

**e. Batteries and Battery Box Installation**

1. Install shield (19) on battery box (6) with five screws (18) and new locknuts (20).
2. Install two washers (9) and thumbscrews (10) on battery box (6) with two nuts (8).
3. Install battery box (6) on battery box support (7).

**NOTE**

Assistant will help with step 4.

4. Place two batteries (5) in battery box (6). Install battery holddown (3) on battery box (6) and batteries (5) with four J-bolts (4), new lockwashers (2), and nuts (1).

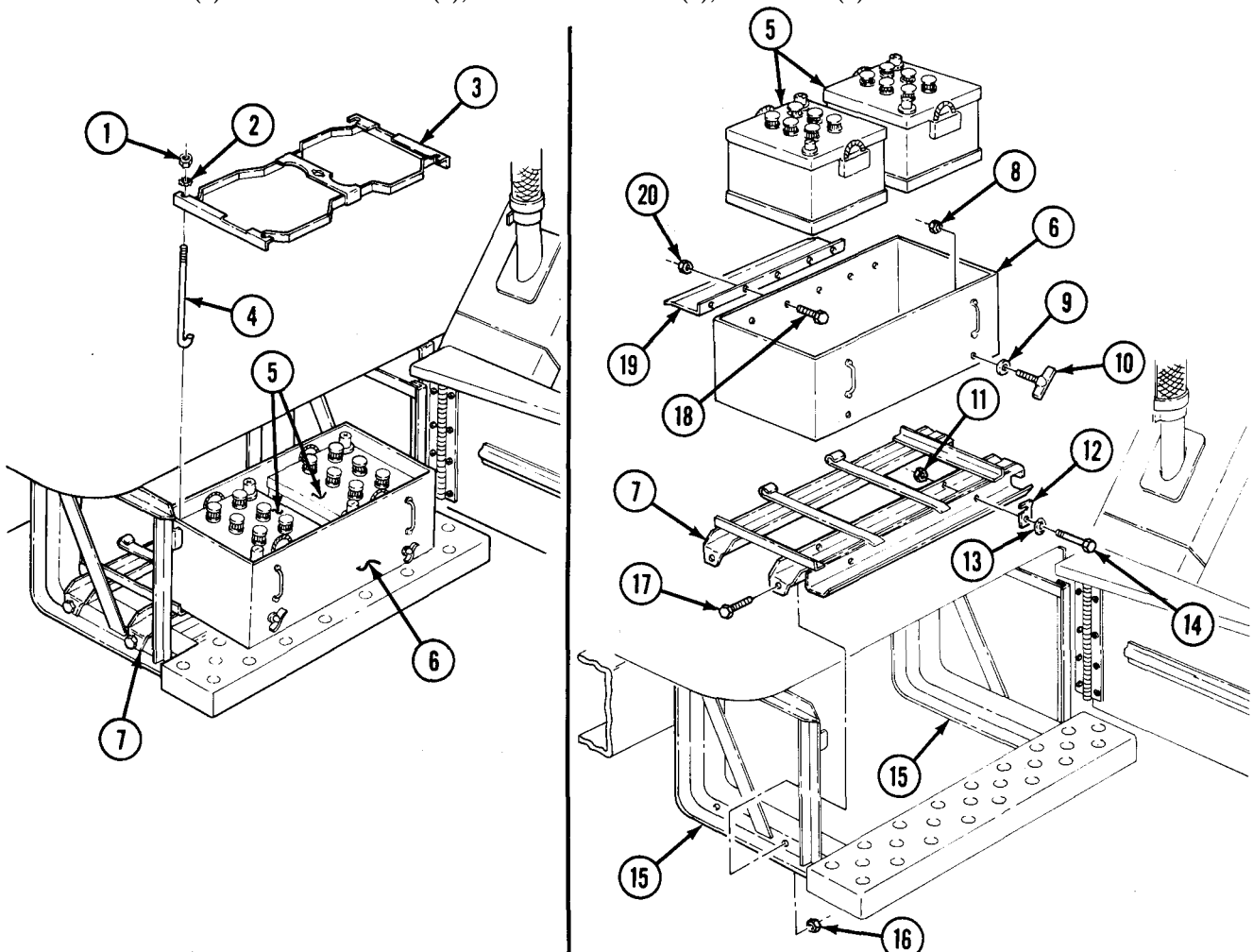

FOLLOW-ON TASK: Install battery clamps (para. 4-48).

## Section VI. WIRING HARNESS MAINTENANCE

## 4-50. WIRING HARNESS MAINTENANCE INDEX

PARA. NO.	TITLE	PAGE NO.
4-51.	Wiring Harness Connector Repair	4-79
4-52.	Cab Protector Wiring Harness Replacement (M756A2)	4-82

## 4-51. WIRING HARNESS CONNECTOR REPAIR

This task covers:

- |   |                               |
|---|-------------------------------|
| a. Terminal-Type Cable Connector Repair | d. Connector Assembly Repair  |
| b. Male Cable Connector Repair          | e. Receptacle Assembly Repair |
| c. Female Cable Connector Repair        |                               |

INITIAL SETUP:

APPLICABLE MODELS

All

EQUIPMENT CONDITION

Battery ground cable disconnected (para. 4-48).

REFERENCES (TM)

TM 9-237  
TM 9-2320-361-20P

## a. Terminal-Type Cable Connector Repair

- Strip cable insulation (1) from cable (2) to equal depth of terminal well (4).
- Slide insulator (3) over cable insulation (1).
- Insert cable (2) into terminal well (4) and crimp.
- Slide insulator (3) over crimped end of terminal (5).

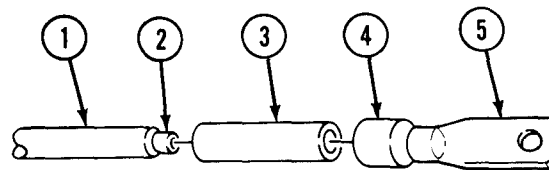

**4-51. WIRING HARNESS CONNECTOR REPAIR (Contd)**

**b. Male Cable Connector Repair**

1. Strip cable insulation (1) from cable (2) to equal depth of terminal well (5).
2. Slide shell (3) over cable insulation (1).
3. Insert cable (2) into terminal well (6) and crimp.
4. Place slotted washer (4) over crimped junction at terminal (6).
5. Slide shell (3) over slotted washer (4) and terminal (6).

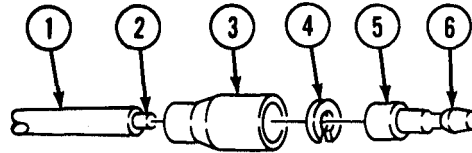

**c. Female Cable Connector Repair**

1. Strip cable insulation (7) from cable (8) to equal depth of terminal well (11).
2. Slide shell (9) and sleeve (10) over cable insulation (7).
3. Insert cable (8) into terminal well (11) and crimp.
4. Slide shell (9) and sleeve (10) over terminal (12).

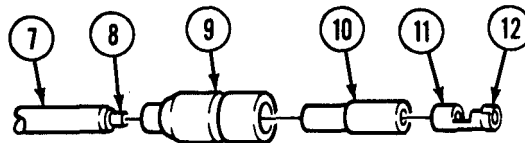

**d. Connector Assembly Repair**

**NOTE**

Refer to TM 9-237 for soldering instructions.

1. Strip cable insulation (13) to depth of solder wells (16) on inserts (17).
2. Slide cable ends (20) through grommet retaining nut (14) and grommet (16).
3. Place cable ends (20) into solder wells (16) and solder.
4. Slide grommet (15) over inserts (17) and press into shell assembly (18) until seated.
5. Screw grommet retaining nut (14) on shell assembly (18) and coupling nut (19) until seated.

4-51. WIRING HARNESS CONNECTOR REPAIR (Contd)

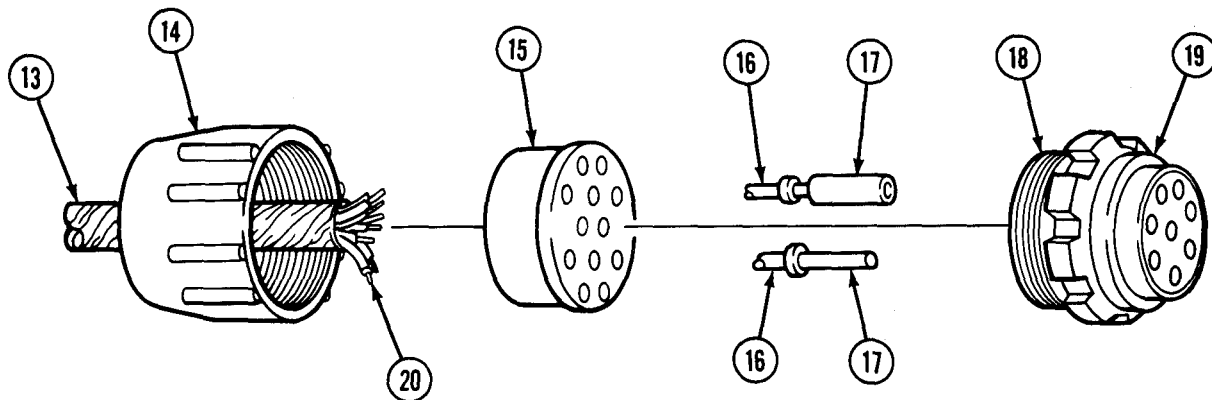

e. Receptacle Assembly Repair

**NOTE**

Refer to TM 9-237 for soldering instructions.

1. Strip cable insulation (21) to depth of solder wells (25) on inserts (26).
2. Slide cable ends (23) through grommet retaining nut (22) and grommet (24).
3. Place cable ends (23) into solder wells (25) and solder.
4. Slide grommet (24) over inserts (26) and press into receptacle (27) until seated.
5. Screw grommet retaining nut (22) onto receptacle (27) until seated.

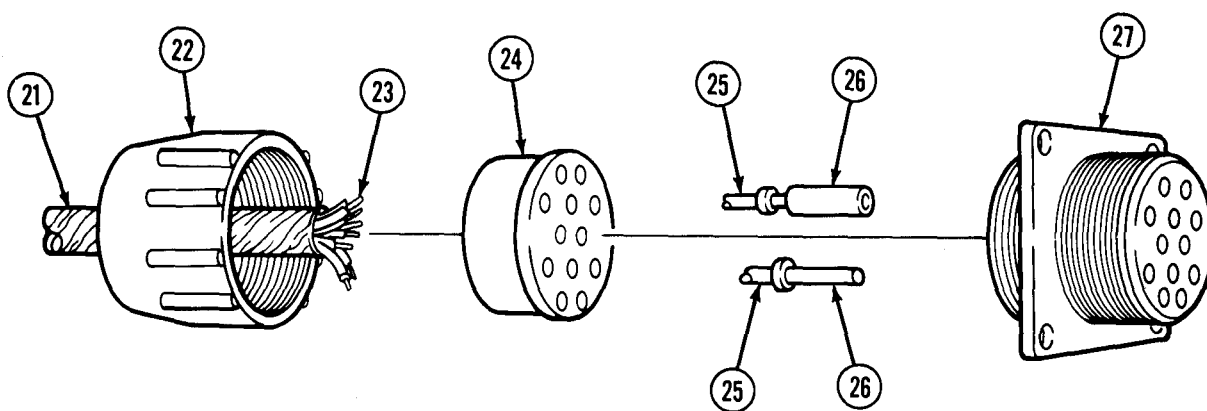

FOLLOW-ON TASK: Connect battery ground cable (para. 4-48).

**4-52. CAB PROTECTOR WIRING HARNESS REPLACEMENT (M756A2)**

This task covers:

**a. Removal**

**b. Installation**

INITIAL SETUP:

APPLICABLE MODELS

M756A2

MATERIALS/PARTS

Two locknuts

Lockwasher

Safety wire (Appendix C, Item 22)

REFERENCES (TM)

TM 9-2320-361-10

TM 9-2320-361-20P

EQUIPMENT CONDITION

- Parking brake set (TM 9-2320-361-10).
- Battery ground cable disconnected (para. 4-48).

**a. Removal**

**CAUTION**

Use care when removing or routing harness. Snagging may result, and forceful pulling will cause damage to harness.

**NOTE**

Tag all leads for installation.

1. Disconnect cab protector wiring harness (2) from two floodlights (5), three clearance light wires (4), and rear wiring harness (11).
2. Remove four grommets (3) from cab protector (1) and cab protector wiring harness (2).
3. Remove locknut (7), screw (16), and clamp (6) from cab protector wiring harness (2) and rear winch support (8). Discard locknut (7).
4. Remove locknut (10), screw (13), lockwasher (14), ground terminal (12), and clamp (15) from crossmember (9) and cab protector wiring harness (2). Discard locknut (10) and lockwasher (14).
5. Remove cab protector wiring harness (2) from cab protector (1).

**b. Installation**

1. Install cab protector wiring harness (2) in cab protector (1).
2. Install four grommets (3) on cab protector wiring harness (2) and cab protector (1).
3. Install clamp (15), ground terminal (12), and cab protector wiring harness (2) on crossmember (9) with new lockwasher (14), screw (13), and new locknut (10).
4. Install clamp (6) on cab protector wiring harness (2) and rear winch support (8) with screw (16) and new locknut (7).
5. Connect cab protector wiring harness (2) to rear wiring harness (11), three clearance light wires (4), and two floodlights (5).

4-52. CAB PROTECTOR WIRING HARNESS REPLACEMENT (M756A2) (Contd)

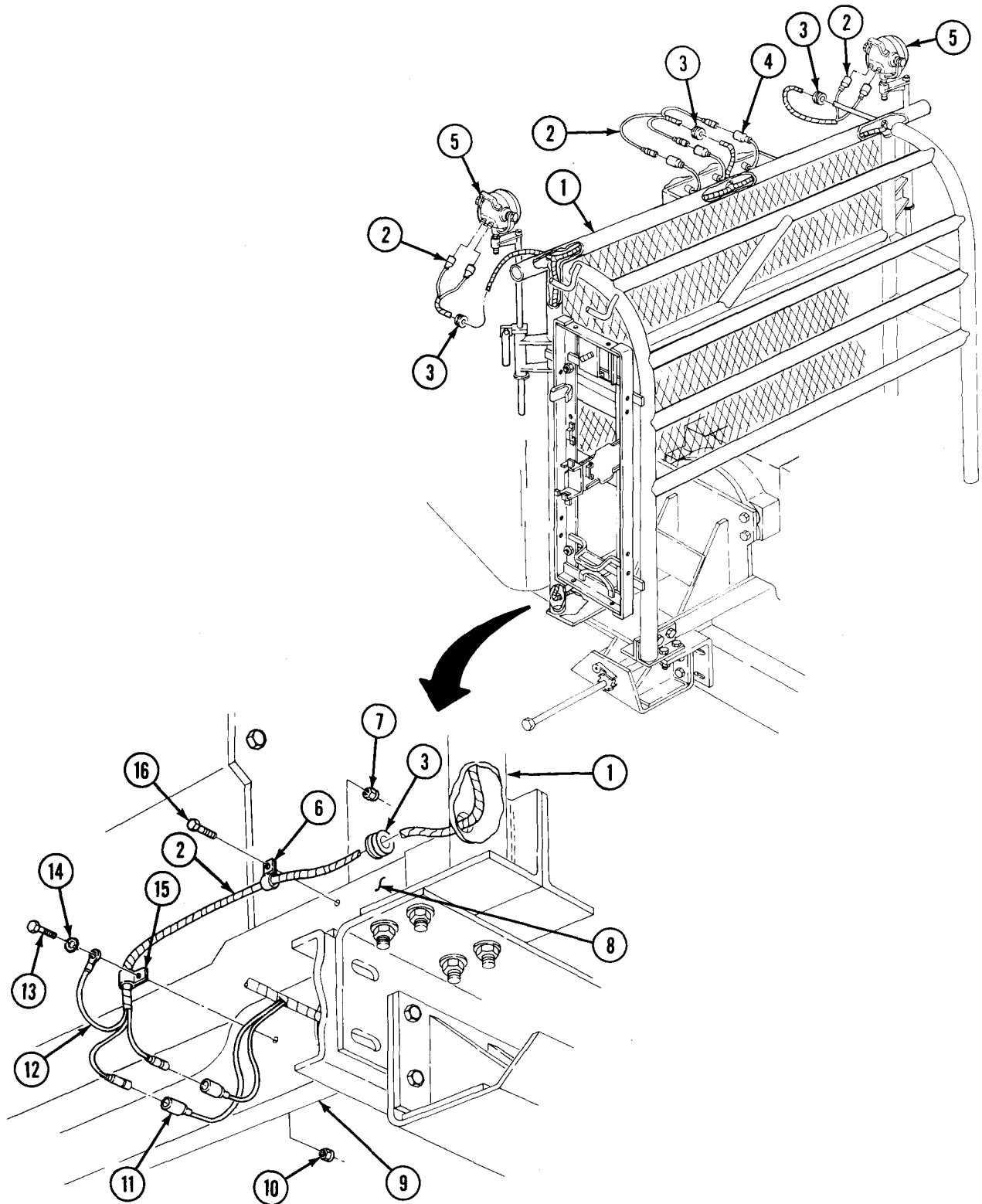

FOLLOW-ON TASK: Connect battery ground cable (para. 4-48).



## CHAPTER 5 TRANSMISSION MAINTENANCE

### 5-1. TRANSMISSION MAINTENANCE INDEX

PARA. NO.	TITLE	PAGE NO.
5-2.	Transmission Breather Maintenance	5-1
5-3.	Transmission (Gearshift Lever Knob and Boot Replacement	5-3
5-4.	Transmission Gearshift Lever Replacement	5-4

### 5-2. TRANSMISSION BREATHER MAINTENANCE

This task covers:

- a. Removal
- b. Cleaning

- c. Installation

INITIAL SETUP:

APPLICABLE MODELS

All

MATERIALS/PARTS

Drycleaning solvent (Appendix C, Item 26)  
Rag (Appendix C, Item 21)

REFERENCES (TM)

TM 9-2320-361-10  
TM 9-2320-361-20P

EQUIPMENT CONDITION

- Parking brake set (TM 9-2320-361-10).
- Cab intermediate tunnel removed (para. 11-22).

GENERAL SAFETY INSTRUCTIONS

Keep fire extinguisher nearby when using drycleaning solvent.



## 5-2. TRANSMISSION BREATHER MAINTENANCE (Contd)

### a. Removal

1. Wipe area around transmission breather hole (2) with rag.
2. Remove transmission breather (1) from transmission housing (3).

### b. Cleaning

#### **WARNING**

Drycleaning solvent is flammable and will not be used near open flame. Use only in well-ventilated places. Failure to do so may result in injury to personnel.

Clean transmission breather (1) with drycleaning solvent.

### c. Installation

Install transmission breather (1) on transmission housing (3).

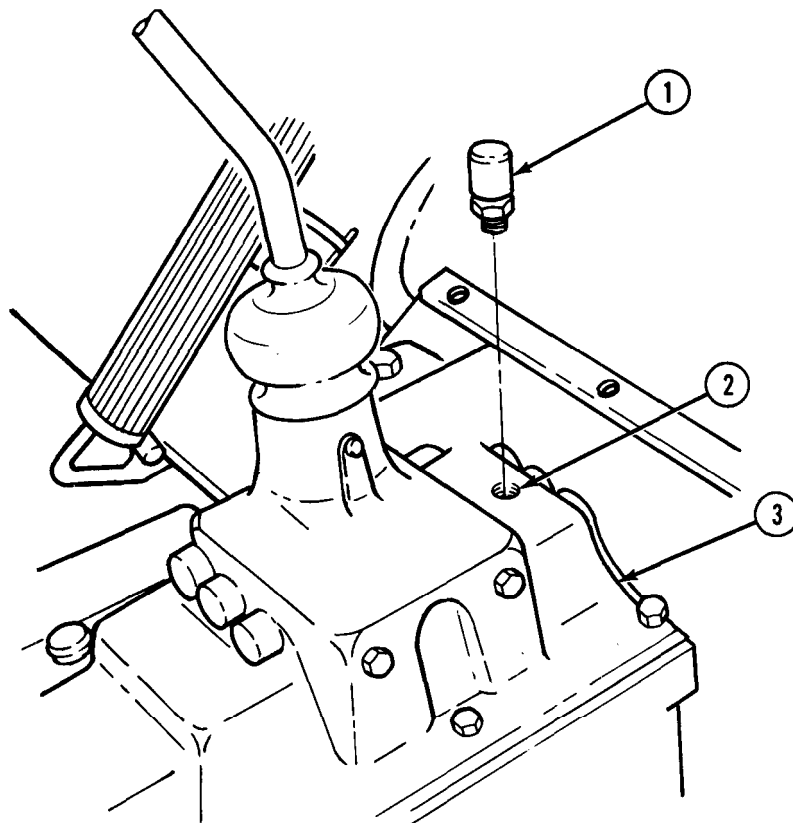

FOLLOW-ON TASK: Install cab intermediate tunnel (para. 11-22).

## 5-3. TRANSMISSION GEARSHIFT LEVER KNOB AND BOOT REPLACEMENT

This task covers:

### a. Removal

### b. Installation

#### INITIAL SETUP

##### APPLICABLE MODELS

All

##### EQUIPMENT CONDITION

Parking brake set (TM 9-2320-361-10).

##### REFERENCES [TM]

TM 9-2320-361-10

TM 9-2320-361-20P

### a. Removal

1. Rotate gearshift knob (1) counterclockwise, and remove from gearshift lever (3).
2. Slide boot (2) up and off ball socket pedestal (4) and gearshift lever (3).

#### CAUTION

Use care during installation to prevent sharp edges from cutting boot.

1. Slide boot (2), small end facing up, over gearshift lever (3) and slide down to fit over ball socket pedestal (4) on transmission housing.
2. Rotate gearshift knob (1) clockwise to install on gearshift lever (3).

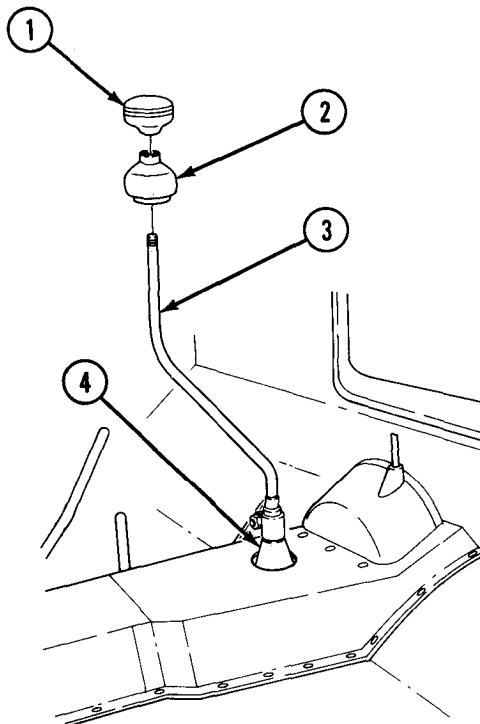

## 5-4. TRANSMISSION GEARSHIFT LEVER REPLACEMENT

This task covers:

**a. Removal**

**b. Installation**

INITIAL SETUP:

APPLICABLE MODELS

All

MATERIALS/PARTS

Lockwasher

REFERENCES (TM)

TM 9-2320-361-20P

EQUIPMENT CONDITION

Transmission gearshift lever knob and boot removed (para. 5-3)

1. Position transmission shifter shaft (3) in neutral.
2. Remove nut (1), lockwasher (2), screw (4), and gearshift lever (3) from transmission shaft (5). Discard lockwasher (2).

Install gearshift lever (3) on transmission shifter shaft (5) with screw (4), new lockwasher (2), and nut (1). Tighten nut (1) 40-50 lb-ft. (54-68 NŹm).

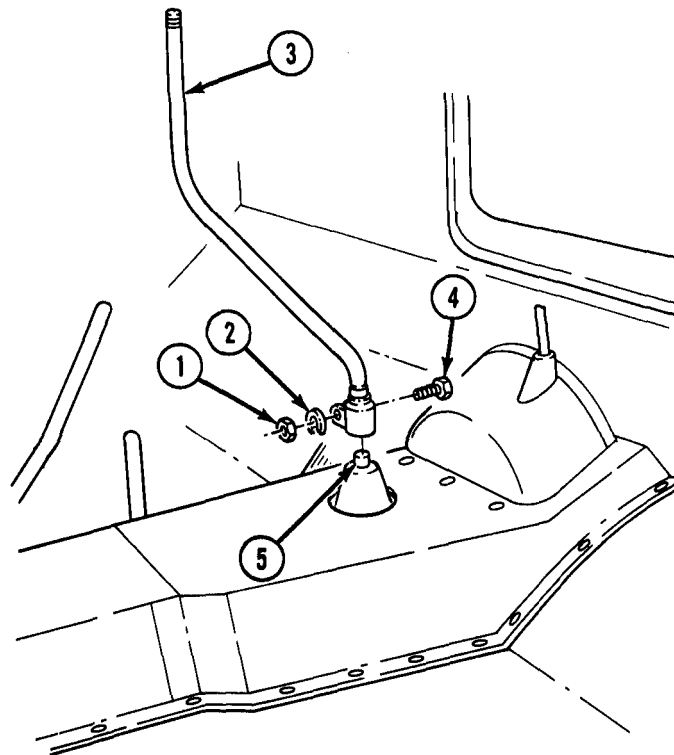

FOLLOW-ON TASK: Install gearshift lever knob and boot (para. 5-3).

## CHAPTER 6 TRANSFER CASE MAINTENANCE

### 6-1. TRANSFER CASE MAINTENANCE INDEX

PARA. NO.	TITLE	PAGE NO.
6-2.	Transfer Case Controls and Linkage Maintenance (W/PTO)	6-1
6-3.	Transfer Case Controls and Linkage Maintenance (W/O PTO)	6-10
6-4.	Front-Wheel Drive Lock-In Switch Maintenance	6-12
6-5.	Transfer Case Breather Maintenance	6-20

### 6-2. TRANSFER CASE CONTROLS AND LINKAGE MAINTENANCE (W/PTO)

This task covers:

- |  |   |
|--|---|
| <ul style="list-style-type: none"> <li>a. Removal</li> <li>b. Cleaning and Inspection</li> </ul> | <ul style="list-style-type: none"> <li>c. Installation</li> <li>d. PTO Lock Adjustment</li> </ul> |
|--|---|

**INITIAL SETUP:**

APPLICABLE MODELS

M49A2C, M50A2, M50A3, M756A2, and M764

MATERIALS/PARTS

Four cotter pins  
 Fifteen locknuts  
 Two bushings  
 Woodruff key  
 Drycleaning solvent (Appendix C, Item 26)  
 Rags (Appendix C, Item 21)

PERSONNEL REQUIRED

Two

REFERENCES (TM)

LO 9-2320-209-12-1  
 TM 9-2320-361-10  
 TM 9-2320-361-20P

EQUIPMENT CONDITION

- Parking brake set (TM 9-2320-361-10).
- Driver's seat removed (para. 11-28).
- Cab tunnels removed (para. 11-22).

GENERAL SAFETY INSTRUCTIONS

Keep fire extinguisher nearby when using drycleaning solvent.

#### a. Removal

1. Place transfer case PTO shift handle (1) in NEUTRAL position and turn shift lever lock (2) parallel to PTO shift handle (1).

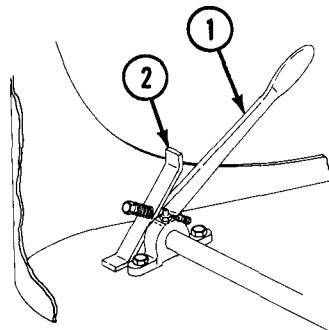

**6-2. TRANSFER CASE CONTROLS AND LINKAGE MAINTENANCE (W/PTO) (Contd)**

**NOTE**

Perform step 2 on vehicles with transfer case lockout arms.

2. Remove two cotter pins (18), washers (17), and rod (24) from lock (16) and lever (19). Discard cotter pins (18).

**NOTE**

Some vehicles are equipped with a screw; others use a shoulder screw. This procedure covers a shoulder screw.

3. Remove two locknuts (14), shoulder screw (11), screw (35), clevis (12), and rod (26) from transfer case shaft (13) and transfer case shift handle (27). Discard locknuts (14).
4. Loosen jamnut (25) and remove clevis (12) and jamnut (25) from rod (26).

**NOTE**

Perform steps 5 and 6 on vehicles equipped with transfer case lockout arms.

5. Remove two locknuts (28), stud (32), lock (16), connector rod (31), and transfer case shift handle (27) from transfer case shifter bracket (29). Discard locknuts (28).
6. Loosen jamnut (34) and remove lock (16) and jamnut (34) from connector rod (31).
7. Remove two locknuts (5) and ball pivot ends (7) from PTO shift lever (6) and shift arm (15). Discard locknuts (5).
8. Loosen two jamnuts (8) and remove two ball pivot ends (7) and jamnuts (8) from rod (9).

**NOTE**

Perform steps 9 through 12 on vehicles equipped with transfer case lockout arms.

9. Remove two cotter pins (10), clevis pins (4) and (38), clevis (3), and rod (1) from PTO shift lever (6) and lever (36). Discard cotter pins (10). Clevis pin (38) remains attached to speed control cable (37) on vehicles with speed control cables.
10. Loosen jamnut (2) and remove clevis (3) and jamnut (2) from rod (1).
11. Remove three locknuts (30), screws (22), and bracket (23) from frame (33) and transfer case shifter bracket (29). Discard locknuts (30).
12. Remove straight pin (20), lever (19) and (36), and two bushings (21) from bracket (23). Discard bushings (21).

**6-2. TRANSFER CASE CONTROLS AND LINKAGE MAINTENANCE (W/PTO) (Contd)**

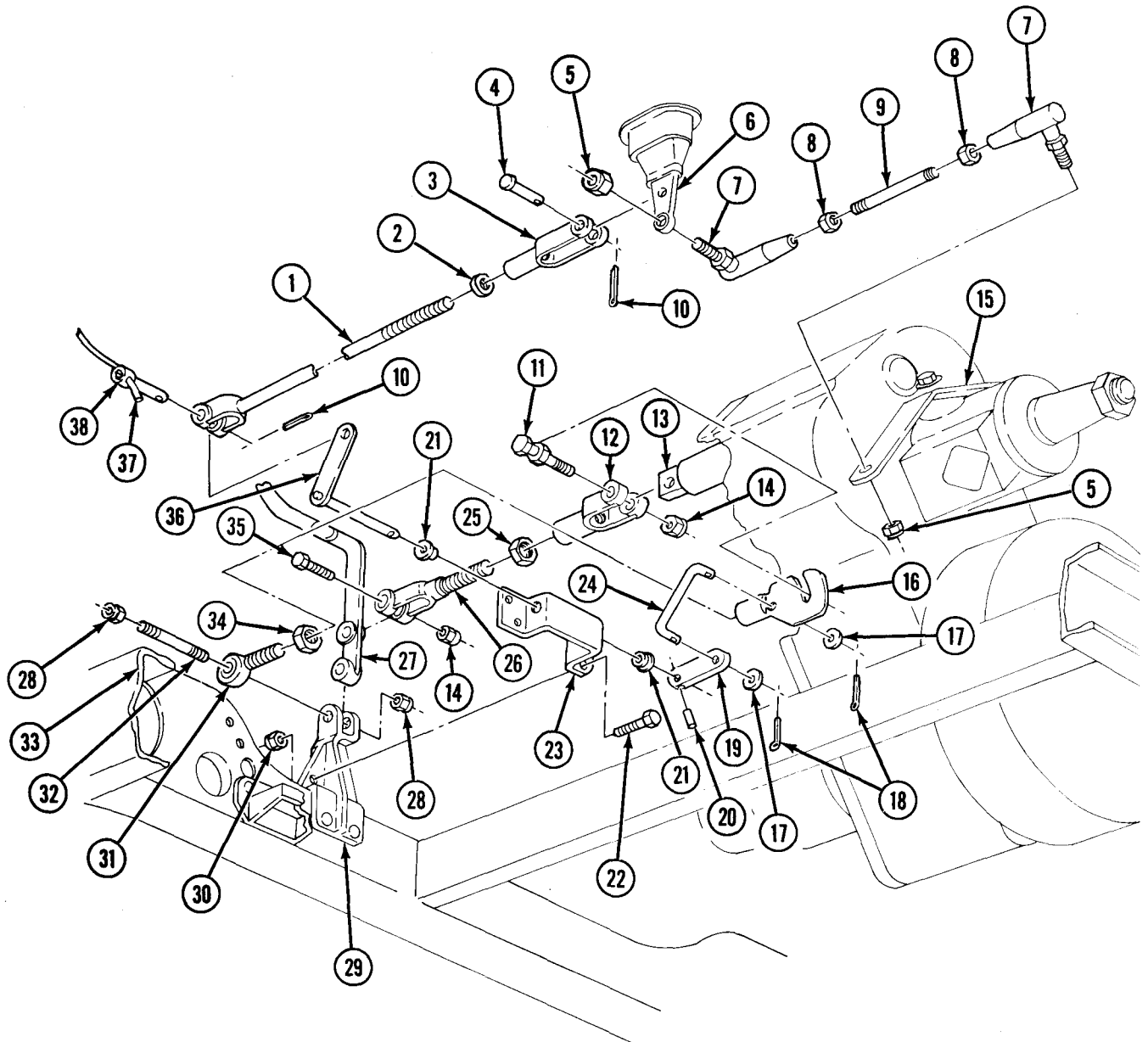

## 6-2. TRANSFER CASE CONTROLS AND LINKAGE MAINTENANCE (W/PTO) (Contd)

### NOTE

Assistant will help with step 13.

13. Remove four locknuts (10), screws (3), and two mounting brackets (1) with PTO shift control (4) from cab floor (9). Discard locknuts (10).
14. Remove seal (13) from cab floor (9).
15. Remove locknut (14), screw (16), lever (15), and woodruff key (12) from PTO shift control shaft (11). Discard locknut (14) and woodruff key (12).
16. Remove two mounting brackets (1) from PTO shift control shaft (11) and remove two lubrication fittings (2) from two mounting brackets (1).
17. Remove locknut (8), screw (7), spring (6), and control lock (5) from PTO shift control handle (4). Discard locknut (8).

### b. Cleaning and Inspection

### WARNING

Drycleaning solvent is flammable and will not be used near open flame. Use only in well-ventilated places. Failure to do so may result in injury to personnel.

1. Clean all parts with drycleaning solvent and wipe dry with clean rag.
2. Inspect all parts for breaks, bends, and cracks. Replace parts if broken, bent, or cracked.
3. Ball and socket joints are not repairable and must be discarded if there is damage or free play. Ball studs must swivel freely.
4. Inspect threaded parts for stripped or crossed threads. Discard threaded parts if threads are stripped or cross-threaded.
5. Inspect spring (6) for breaks, distortion, or collapsed coils. Discard spring (6) if broken, distorted, or coils are collapsed.

### c. Installation

1. Install PTO shift control lock (5) and spring (6) to PTO shift control handle (4) with screw (7) and new locknut (8). Ensure PTO shift control lock (5) turns freely on PTO shift control handle (4).
2. Install two lubrication fittings (2) on two mounting brackets (1) and install mounting brackets (1) on PTO shift control shaft (11).
3. Install new woodruff key (12) and lever (15) on PTO shift control shaft (11) with screw (16) and new locknut (14).
4. Install seal (13) on cab floor (9).

### NOTE

Assistant will help with step 5.

5. Install two mounting brackets (1) with PTO shift control shaft (4) on cab floor (9) with four screws (3) and new locknuts (10).

6-2. TRANSFER CASE CONTROLS AND LINKAGE MAINTENANCE (W/PTO) (Contd)

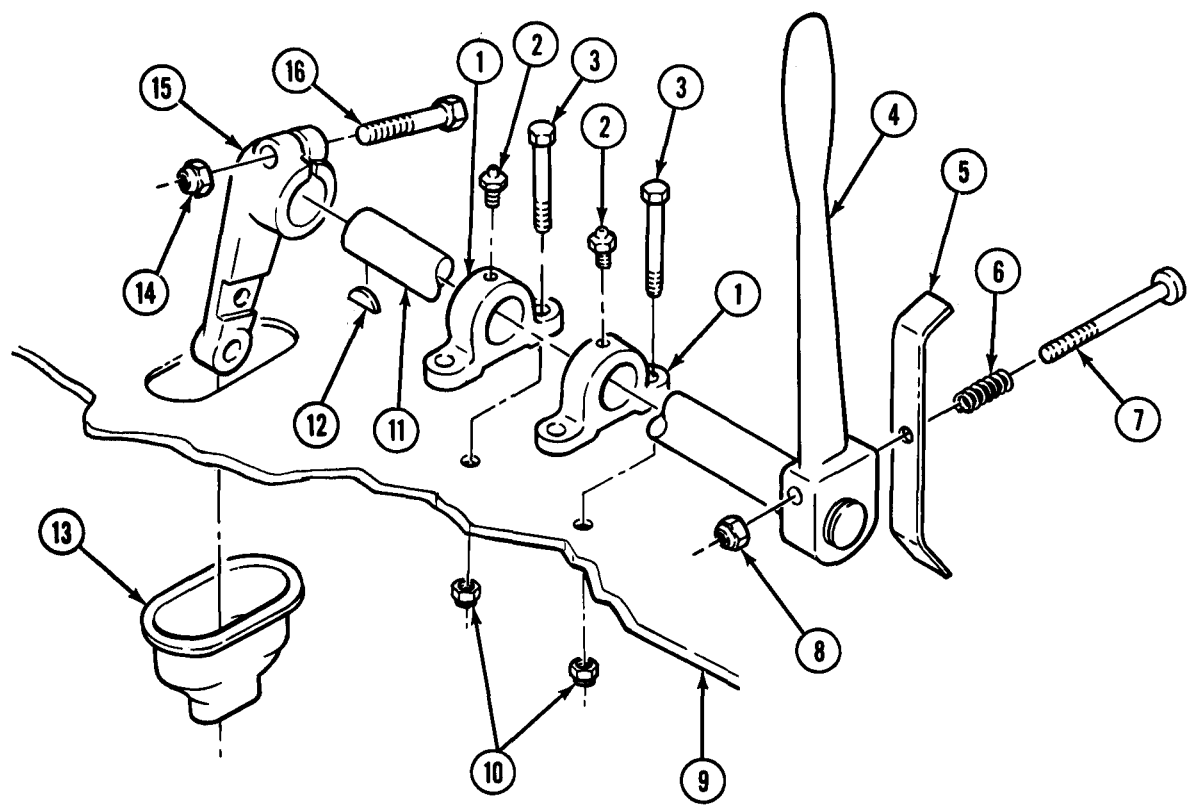



## 6-2. TRANSFER CASE CONTROLS AND LINKAGE MAINTENANCE (W/PTO) (Contd)

### NOTE

Perform steps 6 through 9 on vehicles with transfer case lockout arms.

6. Install two new bushings (21), lever (36) and (19), and straight pin (20) on bracket (23).
7. Install bracket (23) on frame (33) and transfer case shift bracket (29) with three screws (22) and new locknuts (30).
8. Install jamnut (2) and clevis (3) on rod (1) to measure 13.5 in. (34.3 cm) from center on clevis (3) and rod (1). Tighten jamnut (2).
9. Install clevis (3) and rod (1) on PTO shift lever (6) and lever (36) with clevis pins (4) and (37) and two new cotter pins (10).
10. Install two jamnuts (8) and two ball pivot ends (7) on rod (9) to measure 6.9 in. (17.5 cm) from center of ball pivot ends (7). Tighten two jamnuts (8).
11. Install two ball pivot ends (7) on PTO shift lever (6) and shift arm (15) with two new locknuts (5).

### NOTE

Perform steps 12 and 13 on vehicles with transfer case lockout arms.

12. Install jamnut (34) and lock (16) on connector rod (31) to measure 3.8 in. (9.7 cm) from center of connector rod (31) clevis hole and rod hole in lock (16). Tighten jamnut (34).
13. Install lock (16), connector rod (31), and transfer case shift handle (27) on transfer case shifter bracket (29) with stud (32) and two new locknuts (28). Transfer case shift handle (27) must move freely.
14. Install jamnut (25) and clevis (12) on rod (26) to measure 4.9 in. (12.4 cm) from center of clevis (12) hole and rod (26) hole. Tighten jamnut (25).

### NOTE

Some vehicles are equipped with a screw; others use a shoulder screw. This procedure covers a shoulder screw.

15. Install clevis (12) and rod (26) on transfer case shift handle (27) and transfer case shaft (13) with screw (35), shoulder screw (11), and two new locknuts (14).

### NOTE

Perform step 16 on vehicles with transfer case lockout arms.

16. Install rod (24) on lock (16) and lever (19) with two washers (17) and new cotter pins (18).

6-2. TRANSFER CASE CONTROLS AND LINKAGE MAINTENANCE (W/PTO) (Contd)

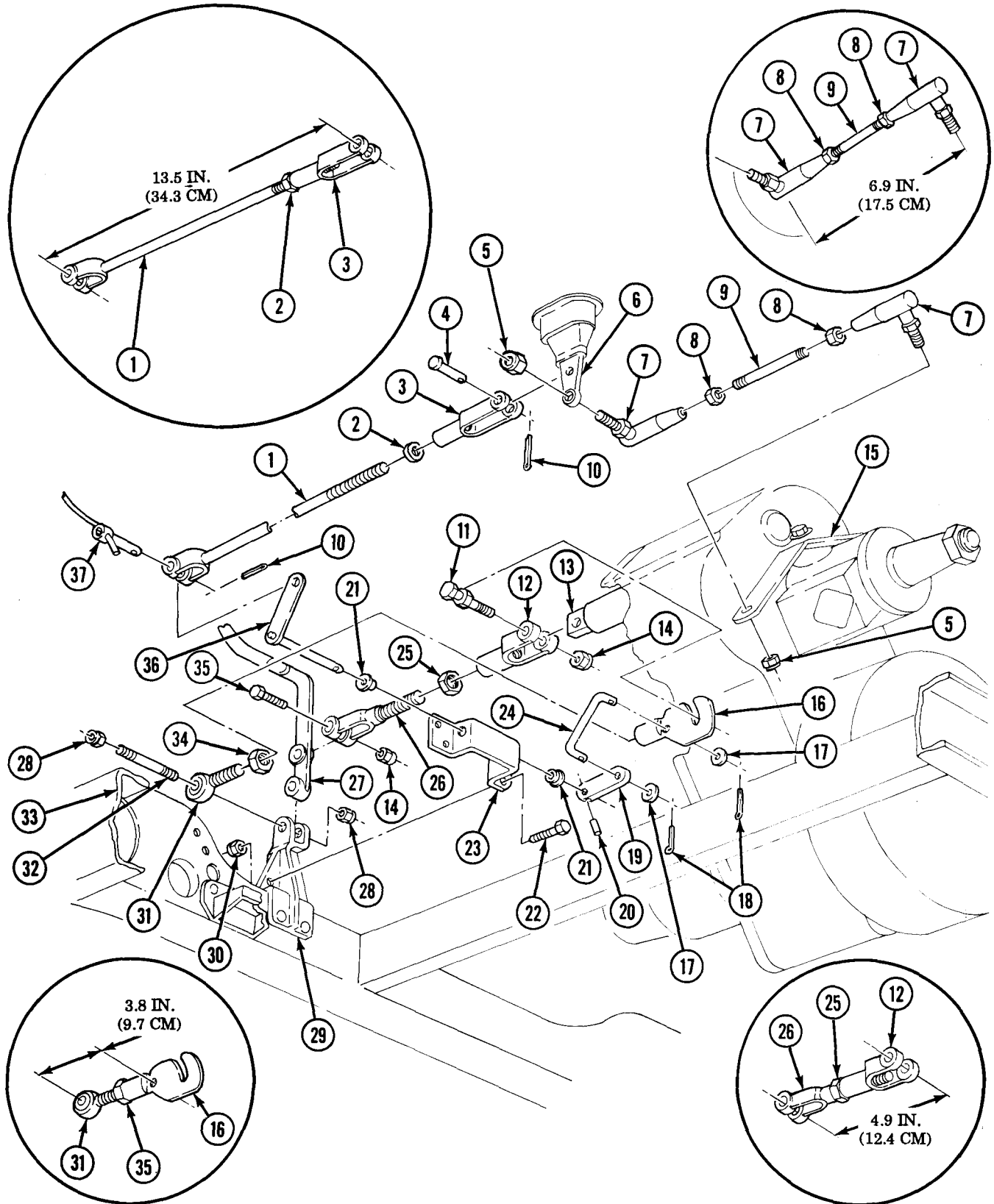

6-2. TRANSFER CASE CONTROLS AND LINKAGE MAINTENANCE (W/PTO) (Contd)

d. PTO Lock Adjustment

1. Ensure transfer case shift handle (10) is in NEUTRAL
2. Move PTO shift control handle (1) to disengaged position and ensure PTO control lock (3) can be turned parallel to handle (1) and prevent rearward movement of PTO shift control handle (1).
3. Remove locknut (13) and ball pivot end (9) from PTO shift lever (5). Discard locknut (13).

**NOTE**

Perform step 4 on vehicles with transfer case lockout arms.

4. Remove cotter pin (6), clevis pin (4), and clevis (12) from PTO shift lever (5). Discard cotter pin (6).
5. Ensure PTO shifter lever (5) is in disengaged position (rear detent).

**NOTE**

Assistant will help with steps 6 through 9.

6. Place PTO control lock (3) parallel to handle (1) and hold tight to cab floor (2).
7. Loosen two jamnuts (8) and adjust (7) to aline ball pivot end (9) to fit freely in PTO shift lever (5) hole. Tighten two jamnuts (8).
8. Connect ball pivot end (9) on PTO shift lever (5) with new locknut (13).

**NOTE**

Perform steps 9 and 10 on vehicles with transfer case lockout arms.

9. Loosen jamnut (11) and adjust clevis (12) to aline holes in clevis (12) with holes in PTO shift lever (5). Tighten jamnut (11).
10. Connect clevis (12) on PTO shift lever (5) with clevis pin (4) and new cotter pin (6).

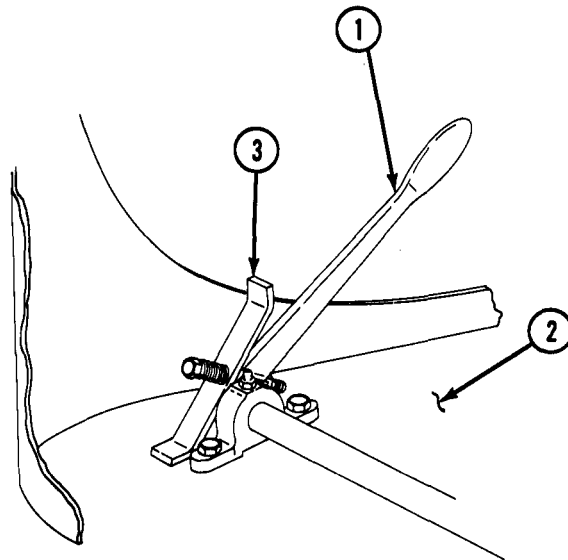

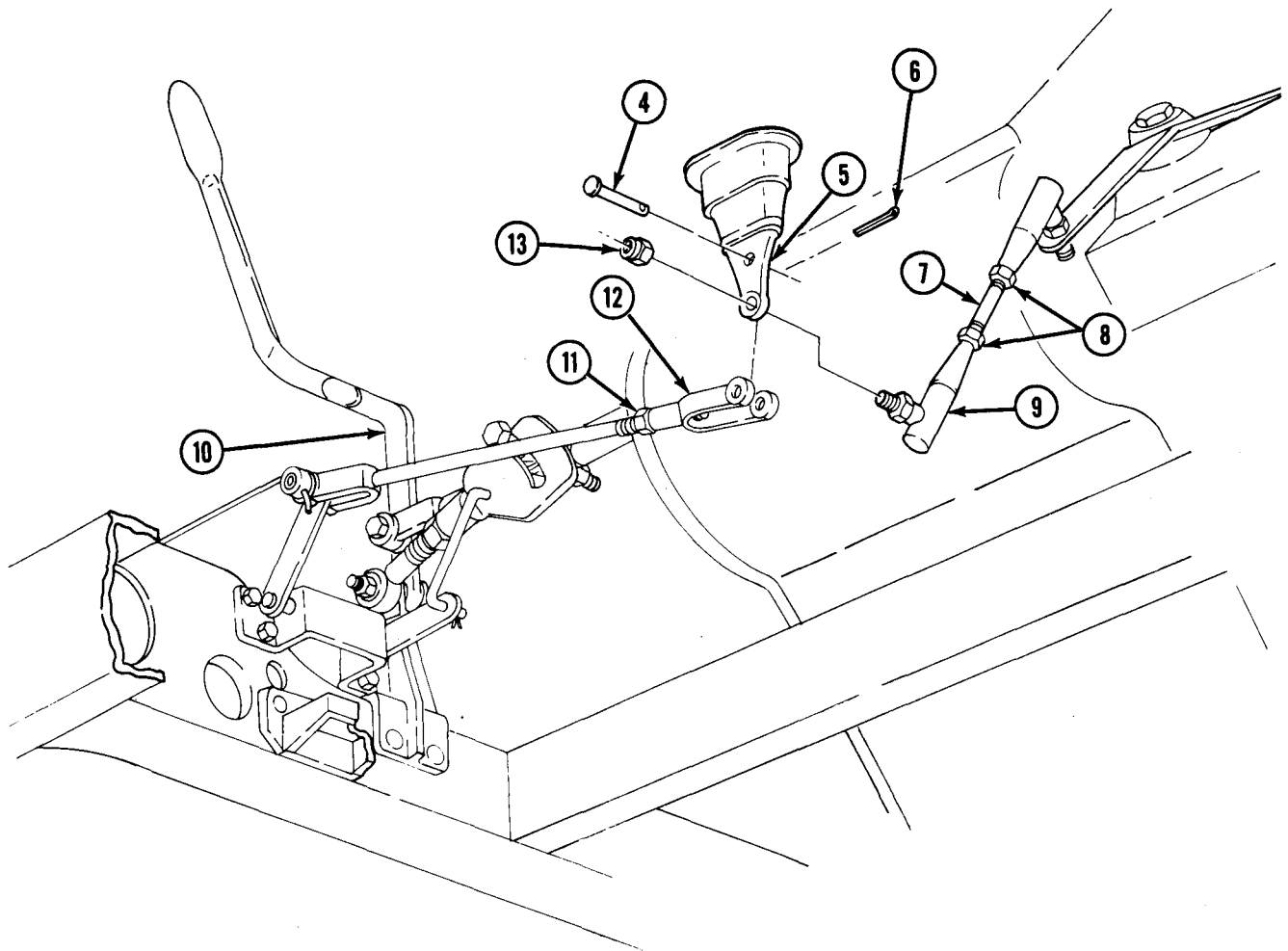
**6-2. TRANSFER CASE CONTROLS AND LINKAGE MAINTENANCE (W/PTO) (Contd)**

- FOLLOW-ON TASKS:**
- Install driver's seat (para. 11-28).
  - Lubricate PTO shift lever (LO 9-2320-209-12-1).
  - Install cab tunnels (para. 11-22).

## 6-3. TRANSFER CASE CONTROLS AND LINKAGE MAINTENANCE (W/O PTO)

This task covers:

- a. Removal
- b. Cleaning and Inspection

- c. Installation

### INITIAL SETUP:

#### APPLICABLE MODELS

All except M49A2C, M50A2, M50A3, M756A2, and M764

#### MATERIALS/PARTS

Three locknuts  
Rags (Appendix C, Item 21)  
Drycleaning solvent (Appendix C, Item 26)

#### REFERENCES (TM)

TM 9-2320-361-10  
TM 9-2320-361-20P

#### EQUIPMENT CONDITION

Parking brake set (TM 9-2320-361-10).

#### GENERAL SAFETY INSTRUCTIONS

Keep fire extinguisher nearby when using drycleaning solvent.

### a. Removal

1. Remove two locknuts (6), screws (3), rod (1), and clevis (4) from transfer case shaft (5) and transfer case shift handle (10). Discard locknuts (6).
2. Loosen jamnut (2) and remove clevis (4) and jamnut (2) from rod (1).
3. Remove locknut (7), screw (9), and transfer case shift handle (10) from transfer case shift bracket (8). Discard locknut (7).

### b. Cleaning and Inspection

#### WARNING

Drycleaning solvent is flammable and will not be used near open flame. Use only in well-ventilated places. Failure to do so may result in injury to personnel.

1. Clean all parts with drycleaning solvent and dry with clean rag.
2. Inspect all parts for breaks, cracks, and bends. If broken, cracked, or bent, replace part.

### c. Installation

1. Install transfer case shift handle (10) on transfer case shift bracket (8) with screw (9) and new locknut (7). Shift handle (10) must move freely.
2. Install jamnut (2) and clevis (4) on rod (1) to measure 4.9 in. (12.4 cm) from center of clevis (4) hole and rod (1) hole. Tighten jamnut (2).
3. Install clevis (4) and rod (1) on transfer case shift handle (10) and transfer case shaft (5) with two screws (3) and new locknuts (6).
4. Move transfer case shift handle (10) through LOW, NEUTRAL, and HIGH positions and verify correct installation of controls.

6-3. TRANSFER CASE CONTROLS AND LINKAGE MAINTENANCE (W/O PTO) (Contd)

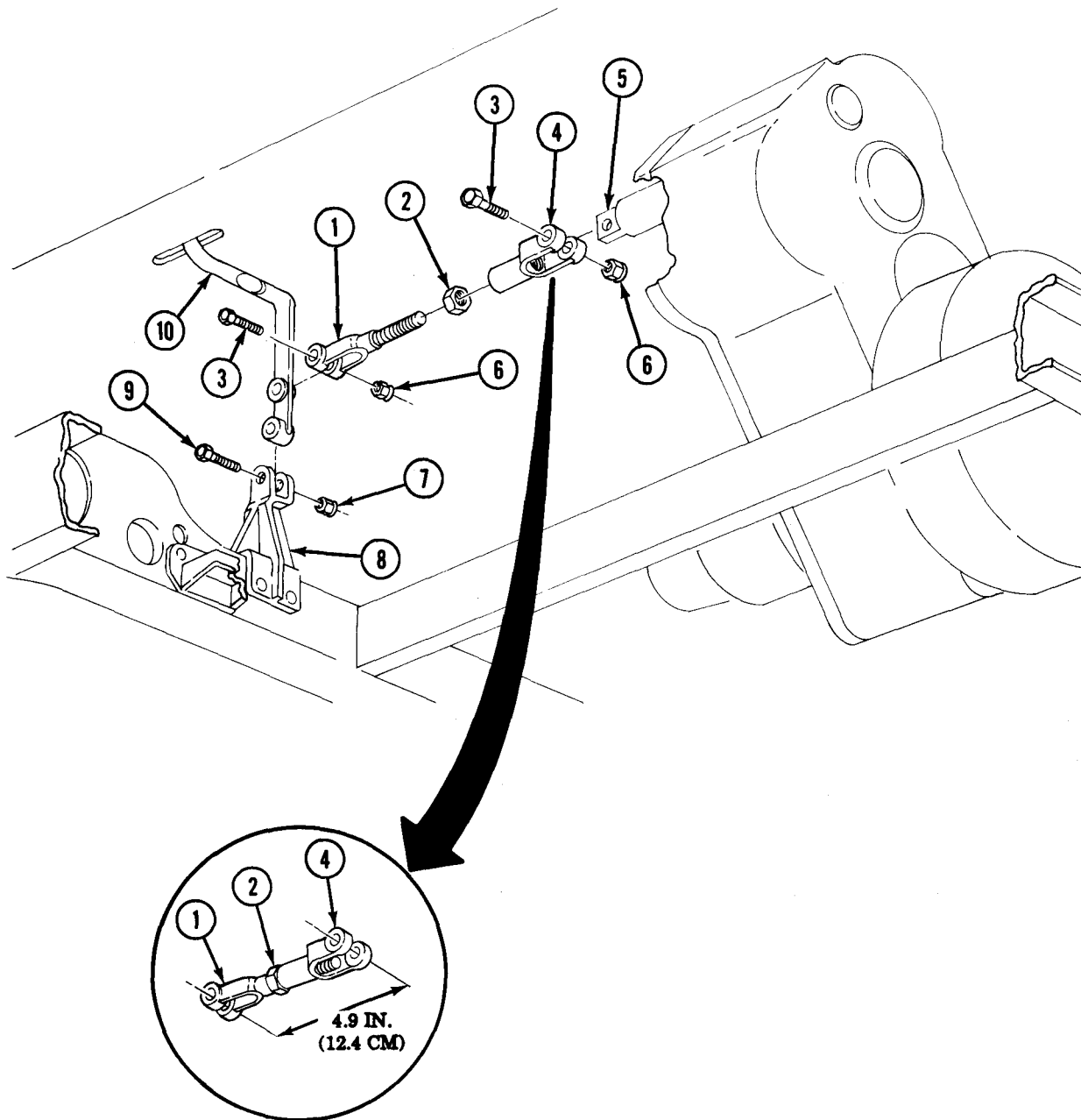

## 6-4. FRONT-WHEEL DRIVE LOCK-IN SWITCH MAINTENANCE

This task covers:

- |                                  |                                       |
|----------------------------------|---------------------------------------|
| a. Air Valve and Bracket Removal | d. Repair                             |
| b. Line Removal                  | e. Line Installation                  |
| c. Cleaning and Inspection       | f. Air Valve and Bracket Installation |

### INITIAL SETUP:

#### APPLICABLE MODELS

All

#### MATERIALS/PARTS

Six locknuts

Four sleeves

Antiseize tape (Appendix C, Item 27)

#### REFERENCES (TM)

TM 9-2320-361-10

TM 9-2320-361-20P

TM 9-243

#### EQUIPMENT CONDITION

- Parking brake set (TM 9-2320-361-10).
- Air reservoirs drained (TM 9-2320-361-10).
- Battery ground cable disconnected (para. 4-48).
- Front-wheel drive lock-in indicator and air pressure switch removed (para. 4-36).

#### GENERAL SAFETY INSTRUCTIONS

Do not disconnect air lines before draining air reservoirs.

### a. Air Valve and Bracket Removal

#### WARNING

Do not disconnect air lines before draining air reservoirs. Small parts under pressure may shoot out with high velocity, causing injury to personnel.

#### NOTE

Tag all lines for installation.

1. Remove two screws (10), decal plate (9), and air valve (12) from bracket (8).
2. Remove line (4) and sleeve (5) from elbow (7). Discard sleeve (5).
3. Remove hose (1) from adapter (13) and pipe tee (3).
4. Remove elbow (7) and adapter (13) from air valve (12).
5. Remove two screws (11), locknuts (6), and bracket (8) from dash panel (2). Discard locknuts (6).

**6-4. FRONT-WHEEL DRIVE LOCK-IN SWITCH MAINTENANCE (Contd)**

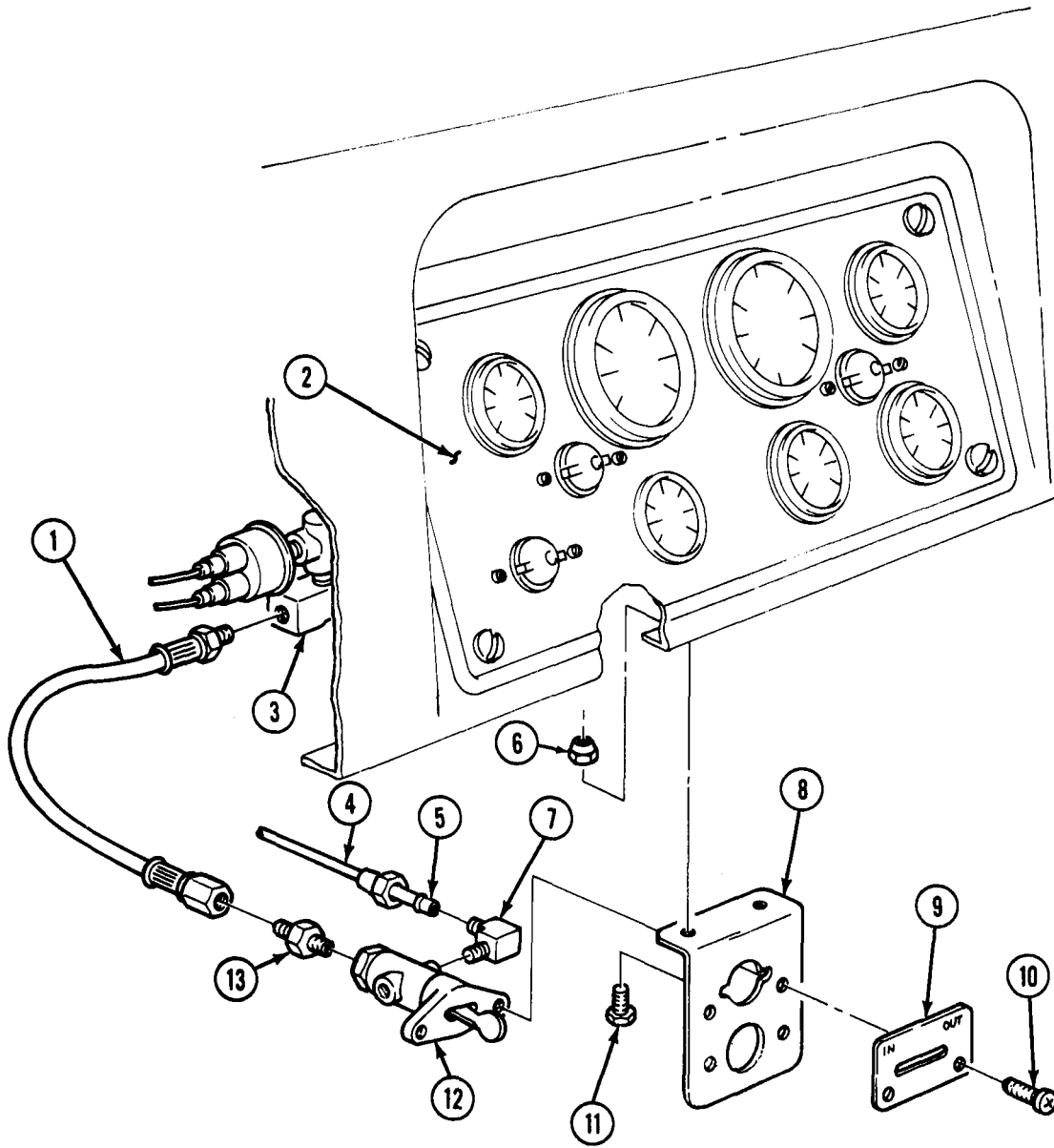



## 6-4. FRONT-WHEEL DRIVE LOCK-IN SWITCH MAINTENANCE (Contd)

### b. Line Removal

1. Remove line (2) and sleeve (3) from adapter (4). Discard sleeve (3).
2. Remove line (7) and sleeve (8) from adapter (4). Discard sleeve (8).
3. Remove locknut (6), washer (5), and adapter (4) from firewall (1). Discard locknut (6).
4. Remove screw (9), clamp (10), and line (7) from firewall (1).
5. Remove locknut (12), screw (26), clamp (13), and line (7) from frame (11). Discard locknut (12).
6. Remove line (7) and sleeve (23) from adapter (22). Discard sleeve (23).
7. Remove adapter (22) from elbow (24).
8. Loosen nut (21) and remove hose (18) from adapter (20).
9. Remove adapter (20) from elbow (24).
10. Loosen nut (17) and remove hose (18) from elbow (16).
11. Remove elbow (16) from air cylinder (15).
12. Remove two locknuts (14), screws (19), and elbow (24) from frame crossmember (25). Discard two locknuts (14).

### c. Cleaning and Inspection

1. Inspect all lines for bends, breaks, and kinks. If bent, broken, or kinked, replace lines.
2. Inspect all hoses for chafing, abrasions, leaks, cracks, bulges, and pinches. If chafed, abraded, leaking, cracked, bulging, or pinched, replace hose.
3. Clean all fittings of dirt and tape sealant.

6-4. FRONT-WHEEL DRIVE LOCK-IN SWITCH MAINTENANCE (Contd)

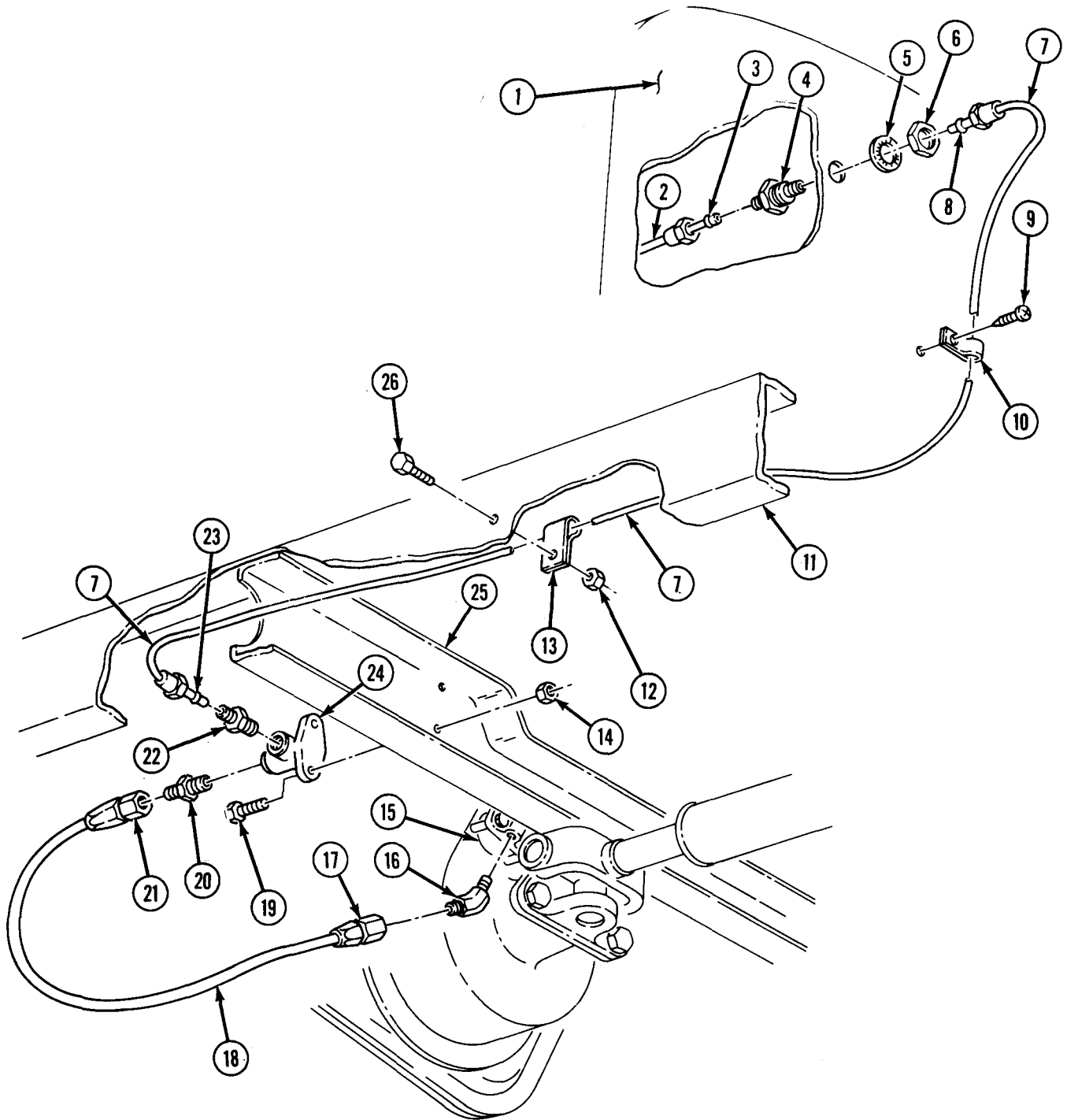

## 6-4. FRONT-WHEEL DRIVE LOCK-IN SWITCH MAINTENANCE (Contd)

1. For fabrication of air lines, refer to TM 9-243.
2. For schematic representation of air line locations and routings see Appendix E of this manual.

### **e. Line Installation**

1. Install elbow (22) on frame crossmember (23) with two screws (18) and new locknuts (14).
2. Install elbow (16) on air cylinder (15).
3. Install hose (17) on elbow (16).
4. Install adapter (19) on elbow (22).
5. Install hose (17) on adapter (19).
6. Install adapter (20) on elbow (22).
7. Install new sleeve (21) and line (7) on adapter (20).
8. Install line (7) on frame (11) with clamp (13), screw (24), and new locknut (12).
9. Install line (7) on firewall (1) with clamp (10) and screw (9).
10. Install adapter (4), washer (5), and new locknut (6) on firewall (1).
11. Install new sleeve (8) and line (7) on adapter (4).
12. Install new sleeve (3) and line (2) on adapter (4).

6-4. FRONT-WHEEL DRIVE LOCK-IN SWITCH MAINTENANCE (Contd)

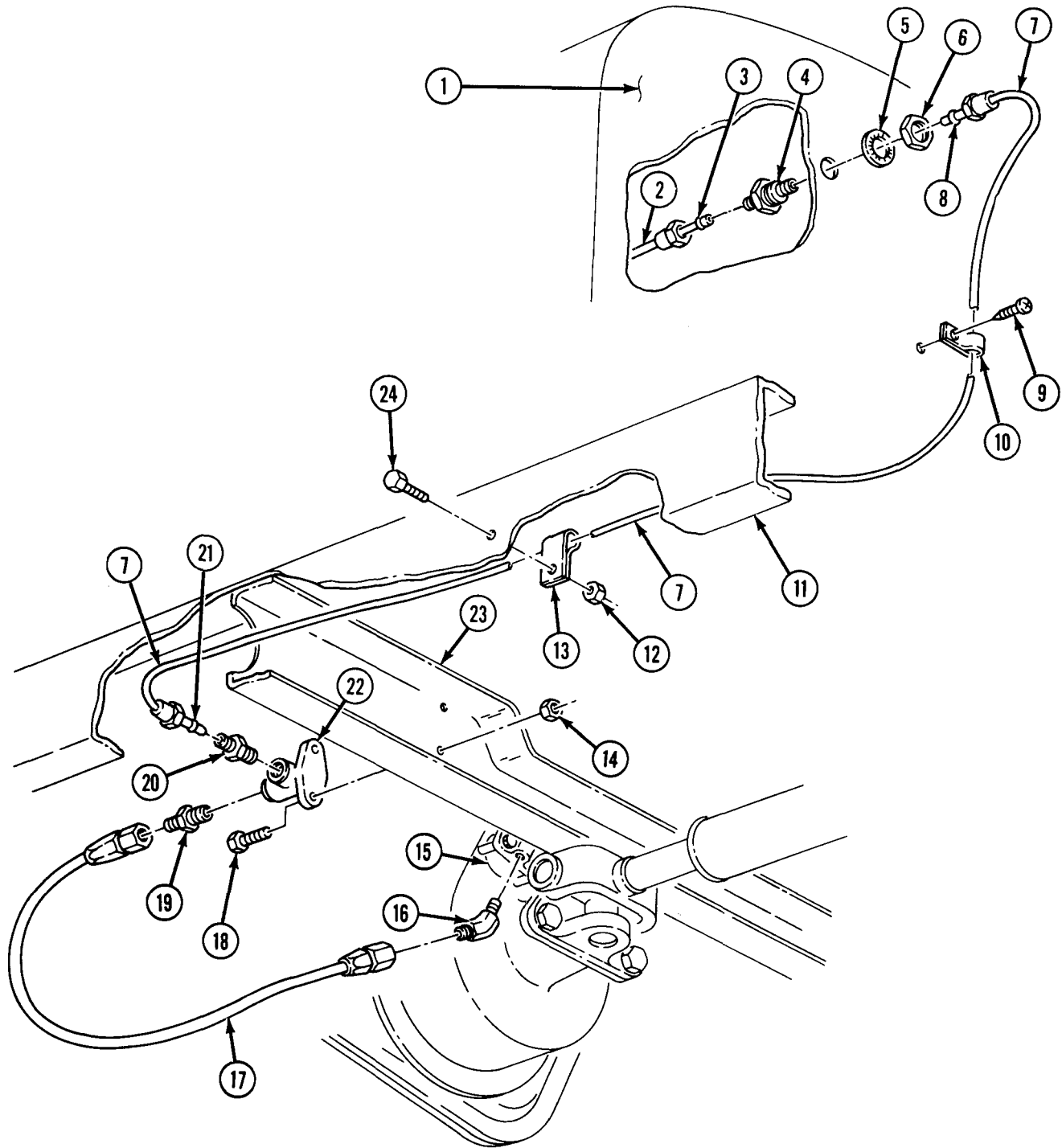

## 6-4. FRONT-WHEEL DRIVE LOCK-IN SWITCH MAINTENANCE (Contd)

### f. Air Valve and Bracket Installation

1. Install bracket (8) on dash panel (2) with two screws (11) and new locknuts (6).

**NOTE**

All male connections must be wrapped with antiseize tape before installation.

2. Install elbow (7) and adapter (13) on air valve (12).
3. Install hose (1) on adapter (13) and pipe tee (3).
4. Install new sleeve (5) and line (4) on elbow (7).
5. Install air valve (12) and decal plate (9) on bracket (8) with two screws (10).

6-4. FRONT-WHEEL DRIVE LOCK-IN SWITCH MAINTENANCE (Contd)

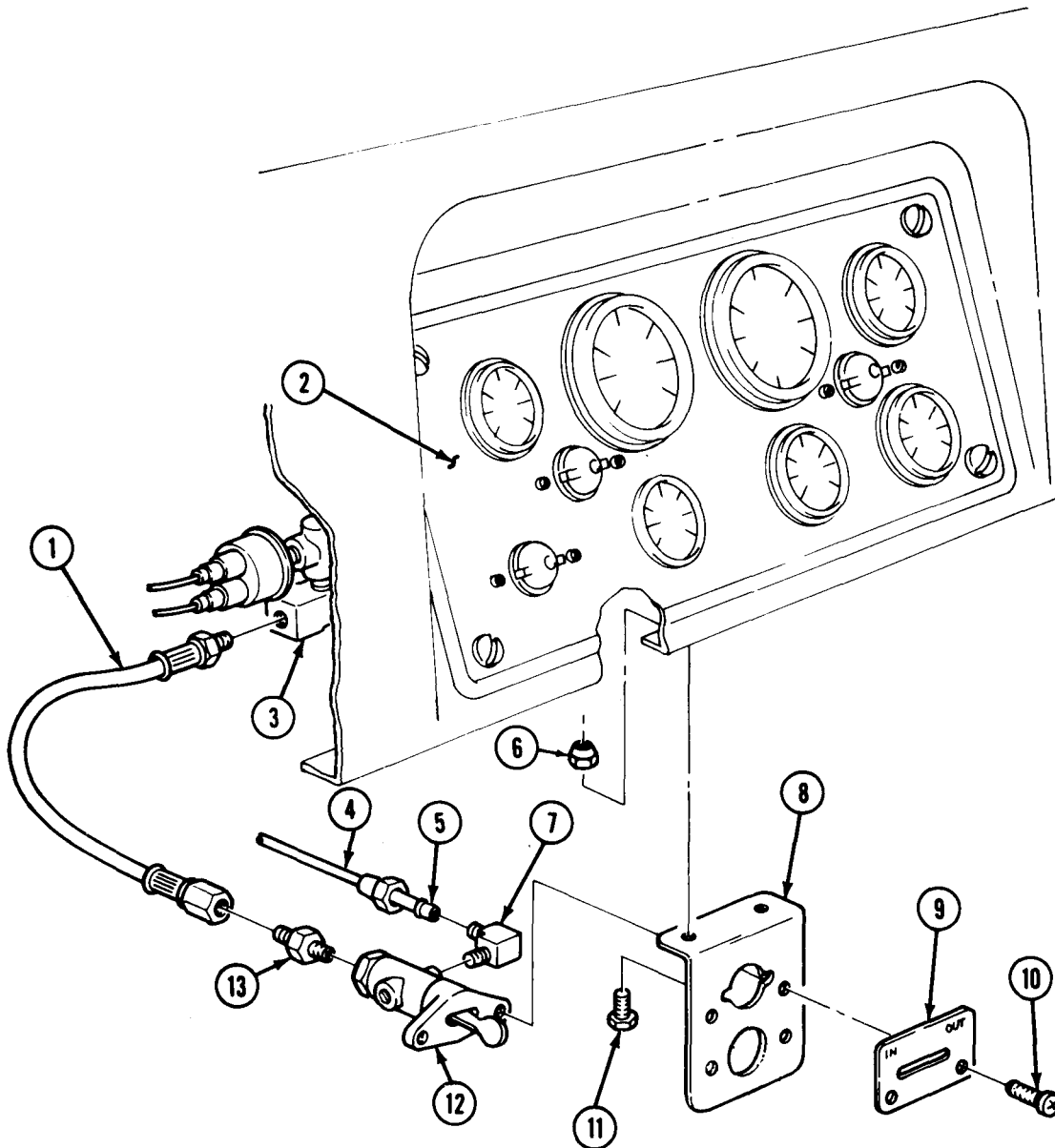

- FOLLOW-ON TASKS:
- Install front-wheel drive lock-in indicator and air pressure switch (para. 4-36).
  - Connect battery ground cable (para. 4-48).
  - Start engine (TM 9-2320-361-10), build up air pressure, and check for leaks.

**6-5. TRANSFER CASE BREATHER MAINTENANCE**

This task covers:

- a. Removal
- b. Cleaning

c. Installation

**INITIAL SETUP:**

APPLICABLE MODELS

All

MATERIALS/PARTS

Rag (Appendix C, Item 21)  
Drycleaning solvent (Appendix C, Item 26)

REFERENCES (TM)

TM 9-2320-361-10  
TM 9-2320-361-20P

EQUIPMENT CONDITION

- Parking brake set (TM 9-2320-361-10).
- Cab tunnels removed (para. 11-22).

GENERAL SAFETY INSTRUCTIONS

Keep fire extinguisher nearby when using drycleaning solvent.

**a. Removal**

1. Wipe area around transfer case breather (2) with rag.
2. Remove transfer case breather (2) from transfer case (1).

**b. Cleaning**

**WARNING**

Drycleaning solvent is flammable and will not be used near open flame. Use only in well-ventilated places. Failure to do so may result in injury to personnel.

Clean transfer case breather (2) with cleaning solvent.

**c. Installation**

Install transfer case breather (2) into transfer case (1).

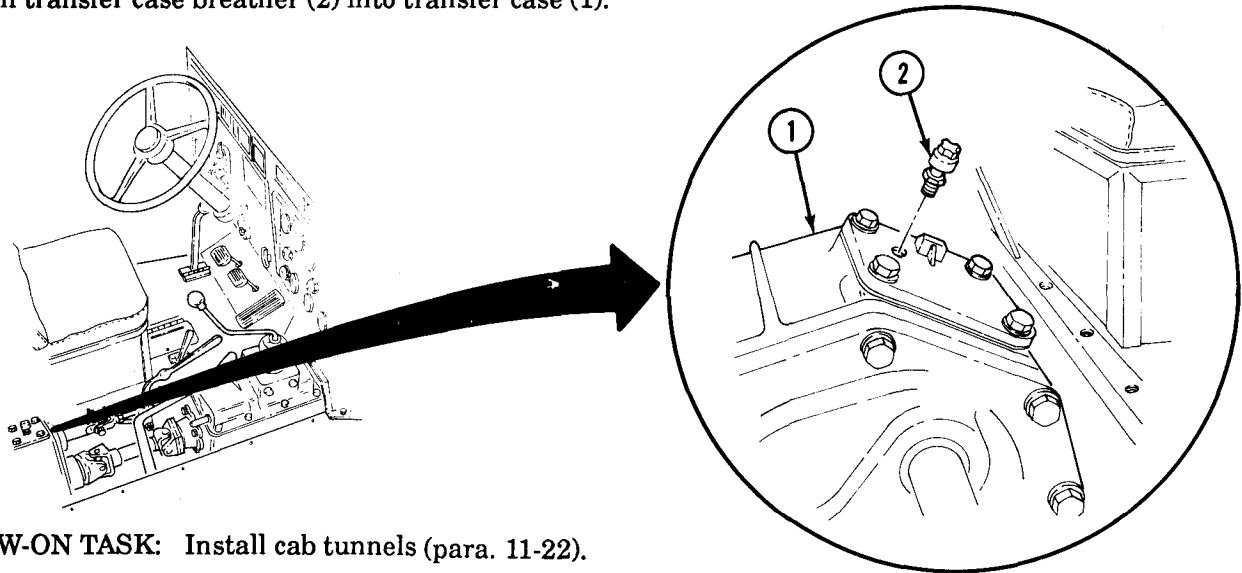

**FOLLOW-ON TASK:** Install cab tunnels (para. 11-22).

## CHAPTER 7 PROPELLER SHAFTS, AXLES, AND SUSPENSION SYSTEM MAINTENANCE

- Section I. Propeller Shafts Maintenance (page 7-1)
- Section II. Front and Rear Axle Maintenance (page 7-15)
- Section III. Front and Rear Suspension Maintenance (page 7-28)

### Section 1. PROPELLER SHAFTS MAINTENANCE

#### 7-1. PROPELLER SHAFTS MAINTENANCE INDEX

PARA. NO.	TITLE	PAGE NO.
7-2.	Propeller Shaft Maintenance	7-1
7-3.	Intermediate Propeller Shaft Maintenance (M36A2)	7-6
7-4.	Universal Joint Maintenance	7-10

#### 7-2. PROPELLER SHAFT MAINTENANCE

This task covers:

- |  |  |
|--|--|
| <ul style="list-style-type: none"> <li>a. Removal</li> <li>b. Disassembly</li> <li>c. Cleaning and Inspection</li> </ul> | <ul style="list-style-type: none"> <li>d. Assembly</li> <li>e. Installation</li> </ul> |
|--|--|

**INITIAL SETUP:**

APPLICABLE MODELS

All (Except intermediate propeller shaft M36A2)

MATERIAL/PARTS

Seal  
 Eight locknuts  
 GAA grease (Appendix C, Item 13)  
 Rags (Appendix C, Item 21)  
 Drycleaning solvent (Appendix C, Item 26)

REFERENCES (TM)

LO 9-2320-209-12-1  
 TM 9-2320-361-10  
 TM 9-2320-361-20P

EQUIPMENT CONDITION

Parking brake set (TM 9-2320-361-10).

GENERAL SAFETY INSTRUCTIONS

Keep fire extinguisher nearby when using drycleaning solvent.



7-2. PROPELLER SHAFT MAINTENANCE (Contd)

a. Removal

**NOTE**

Front transfer to transmission and transmission to differential front propeller shafts are replaced in the same manner. This procedure covers the transmission to differential propeller shaft.

1. Chock two wheels on one side of vehicle and jack up two wheels on opposite side of vehicle.
2. Release parking brake (TM 9-2320-361-10).

**NOTE**

- Mark propeller shaft flange positions for installation.
- Lift wheel and rotate propeller shaft in step 3 to gain access to propeller shaft mounting screws and locknuts.

3. Remove four locknuts (4) from studs (1) and separate flange (3) from flange (10) located in parking brakedrum (2). Discard locknuts (4).
4. Remove four locknuts (5), screws (8), propeller shaft (9), and flange (6) from flange (7). Discard locknuts (5).

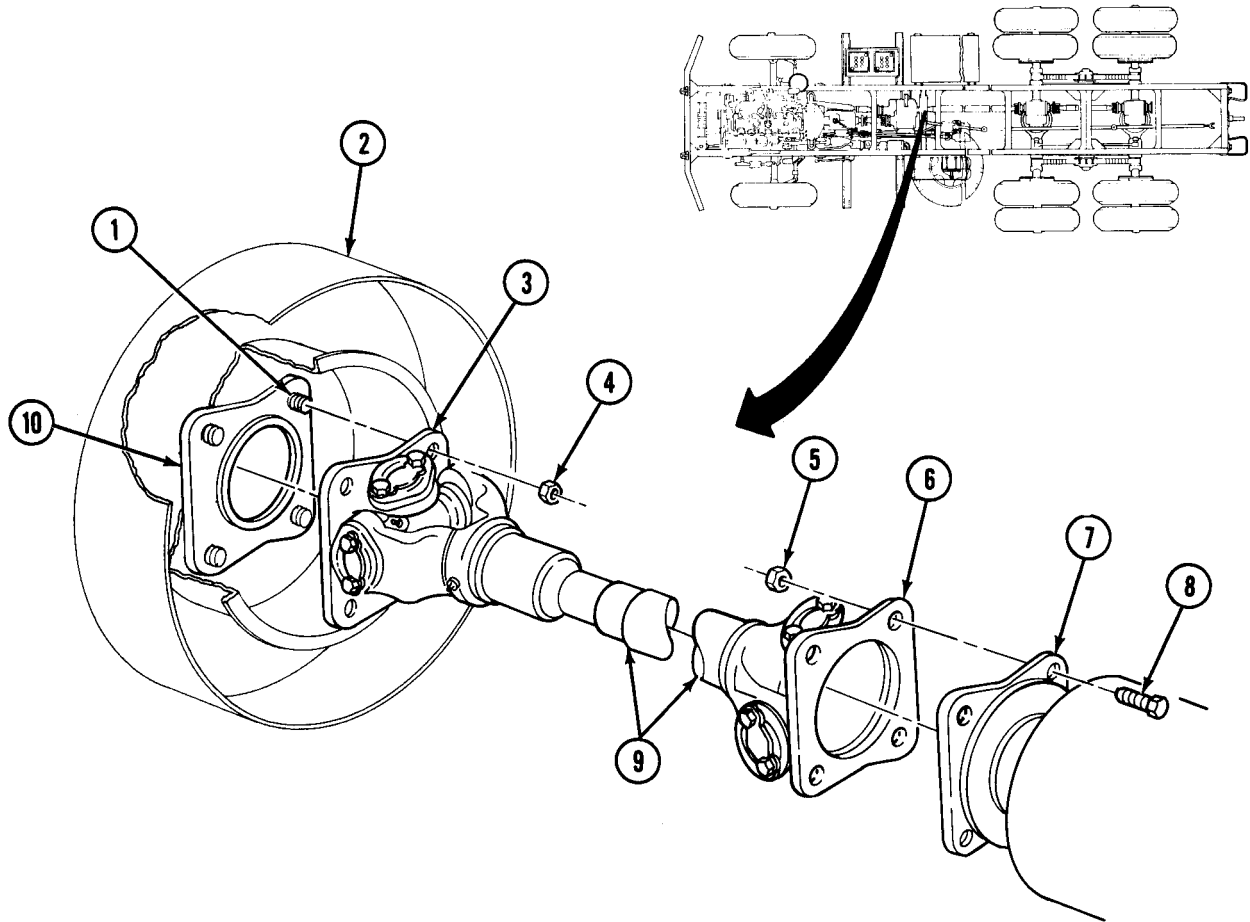

## 7-2. PROPELLER SHAFT MAINTENANCE (Contd)

### b. Disassembly

1. Loosen cap (15) and slide back on shaft (16).
2. Pull shaft (16) out of washer (14), seal (13), and tube of shaft (12).
3. Remove washer (14) and seal (13) from shaft (12). Discard seal (13).

#### NOTE

Perform step 4 if lubrication fitting is damaged.

4. Remove lubrication fitting (18).
5. Remove breather (11) from U-joint end of shaft (12).

### c. Cleaning and Inspection

1. Inspect U-joint for roughness, binding, looseness, and free play. Replace U-joint if there is any roughness, binding, looseness, or free play (para. 7-4).

#### WARNING

Drycleaning solvent is flammable and will not be used near open flame. Use only in well-ventilated places. Failure to do so may result in injury to personnel.

2. Clean splined end of shaft (16) with rag saturated with drycleaning solvent. Dry with clean rag.
3. Clean bore (17) of shaft (12) with drycleaning solvent. Clean outside of shaft (12) with rag saturated with drycleaning solvent.
4. Clean breather (11) and lubrication fitting (18) with drycleaning solvent.
5. Inspect shafts (12) and (16) for:
  - a. Breaks, cracks, or bends. Replace if damaged.
  - b. Crossed or stripped threads, Replace if threads are crossed or stripped.
6. Inspect flanges (3) and (6) for cracks and breaks. Replace flanges (3) and (6) if cracked or broken.

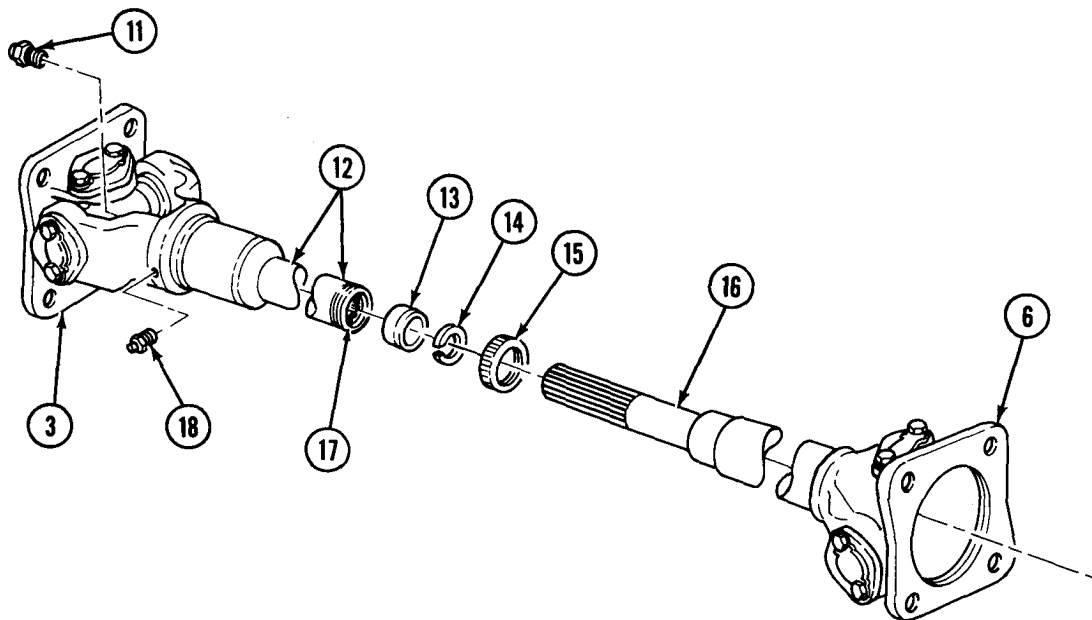

**7-2. PROPELLER SHAFT MAINTENANCE (Contd)**

**d. Assembly**

1. Install breather (2) in shaft (3).

**NOTE**

Perform step 2 if lubrication fitting was removed.

2. Install lubrication fitting (10) in shaft (3).
3. Install new seal (4) in bore (9) of shaft (3).
4. Install cap (6) on shaft (7) with open side toward shaft end and slide up on shaft (7).
5. Install washer (5) on shaft (7).
6. Coat splines on shaft (7) with a thick film of GAA grease.
7. Slide splined end of shaft (7) through seal (4) and into internal splines of shaft (3).
8. Position washer (5) against seal (4) and install cap (6) on shaft (3).

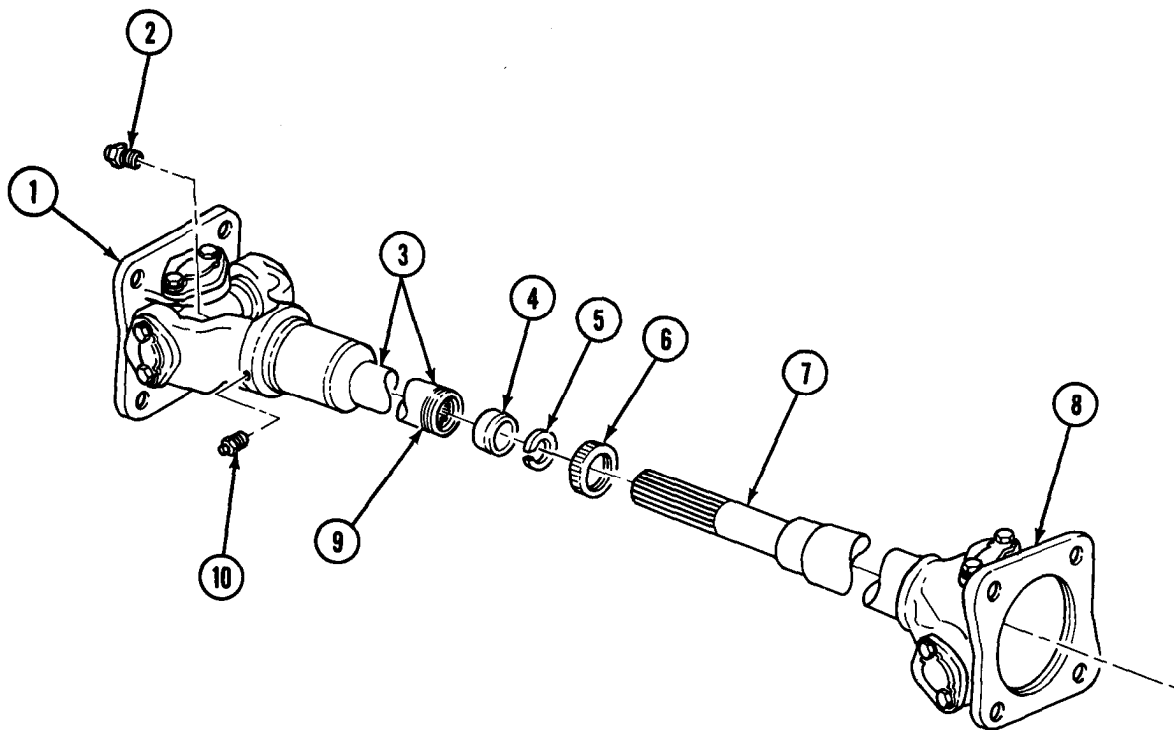

7-2. PROPELLER SHAFT MAINTENANCE (Contd)

**e. Installation**

1. Install propeller shaft (3) and flange (1) on flange (17) inside parking brakedrum (11) with four new locknuts (13). Tighten locknuts (13) 90-120 lb-ft (122-163 N·m).
2. Install flange (8) on flange (15) with four screws (16) and new locknuts (14). Tighten locknuts (14) 90-120 lb-ft (122-163 N·m).
3. Check that propeller shaft assembly has no free play in any direction.
4. Apply parking brake (TM 9-2320-361-10).
5. Lower wheels, and remove chocks.

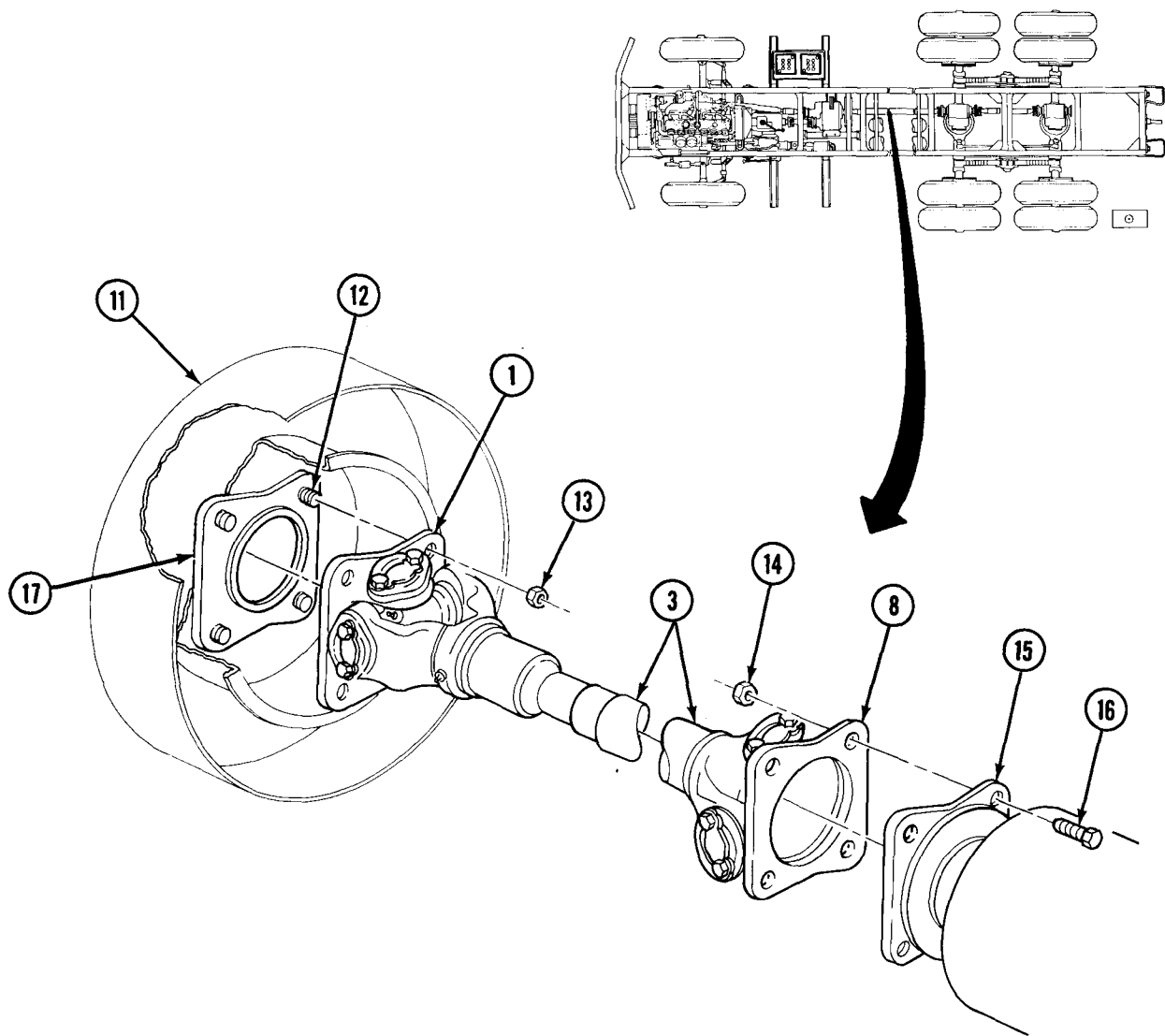

FOLLOW-ON TASK: Lubricate propeller shaft (LO 9-2320-209-12-1).

**7-3. INTERMEDIATE PROPELLER SHAFT MAINTENANCE (M36A2)**

This task covers:

- |                                   |                        |
|-----------------------------------|------------------------|
| <b>a. Removal</b>                 | <b>d. Assembly</b>     |
| <b>b. Disassembly</b>             | <b>e. Installation</b> |
| <b>c. Cleaning and Inspection</b> |                        |

**INITIAL SETUP:**

APPLICABLE MODELS

M36A2

MATERIALS/PARTS

Two seals  
 Ten locknuts  
 Cotter pin  
 Lockwasher  
 GAA grease (Appendix C, Item 13)  
 Drycleaning solvent (Appendix C, Item 26)  
 Rags (Appendix C, Item 21)

PERSONNEL REQUIRED

Two

REFERENCES (TM)

LO 9-2320-209-12-1  
 TM 9-214  
 TM 9-2320-361-20P

EQUIPMENT CONDITION

Forward-rear axle propeller shaft removed (para. 7-2).

GENERAL SAFETY INSTRUCTIONS

Keep fire extinguisher nearby when using drycleaning solvent.

**a. Removal**

1. Remove cotter pin (8), nut (9), washer (10), flange (11), and deflector (12) from shaft (23). Discard cotter pin (8).

**NOTE**

Assistant will help with step 2.

2. Remove two locknuts (16), washers (15), screws (7), propeller shaft (23), and bearing housing (18) from frame support (4). Discard locknuts (16).

**NOTE**

Mark yoke position for installation.

3. Remove four locknuts (25) and flange yoke (24) from flange (26) and studs (1) located in parking brakedrum (2). Discard locknuts (25).
4. Remove four locknuts (3) screws (5), and frame support (4) from crossmember (6). Discard locknuts (3).

**b. Disassembly**

1. Remove bearing housing (18) from propeller shaft (23).
2. Remove screw (22), lockwasher (21), and side shield (20) from propeller shaft (23). Discard lockwasher (21).
3. Remove two seals (13) and bearing (19) from bearing housing (18). Discard seals (13).
4. Remove four rubber insulators (14) from bearing housing (18).

**NOTE**

Perform step 5 if lubrication fitting is damaged.

5. Remove lubrication fitting (17) from bearing housing (18).

7-3. INTERMEDIATE PROPELLER SHAFT MAINTENANCE (M36A2) (Contd)

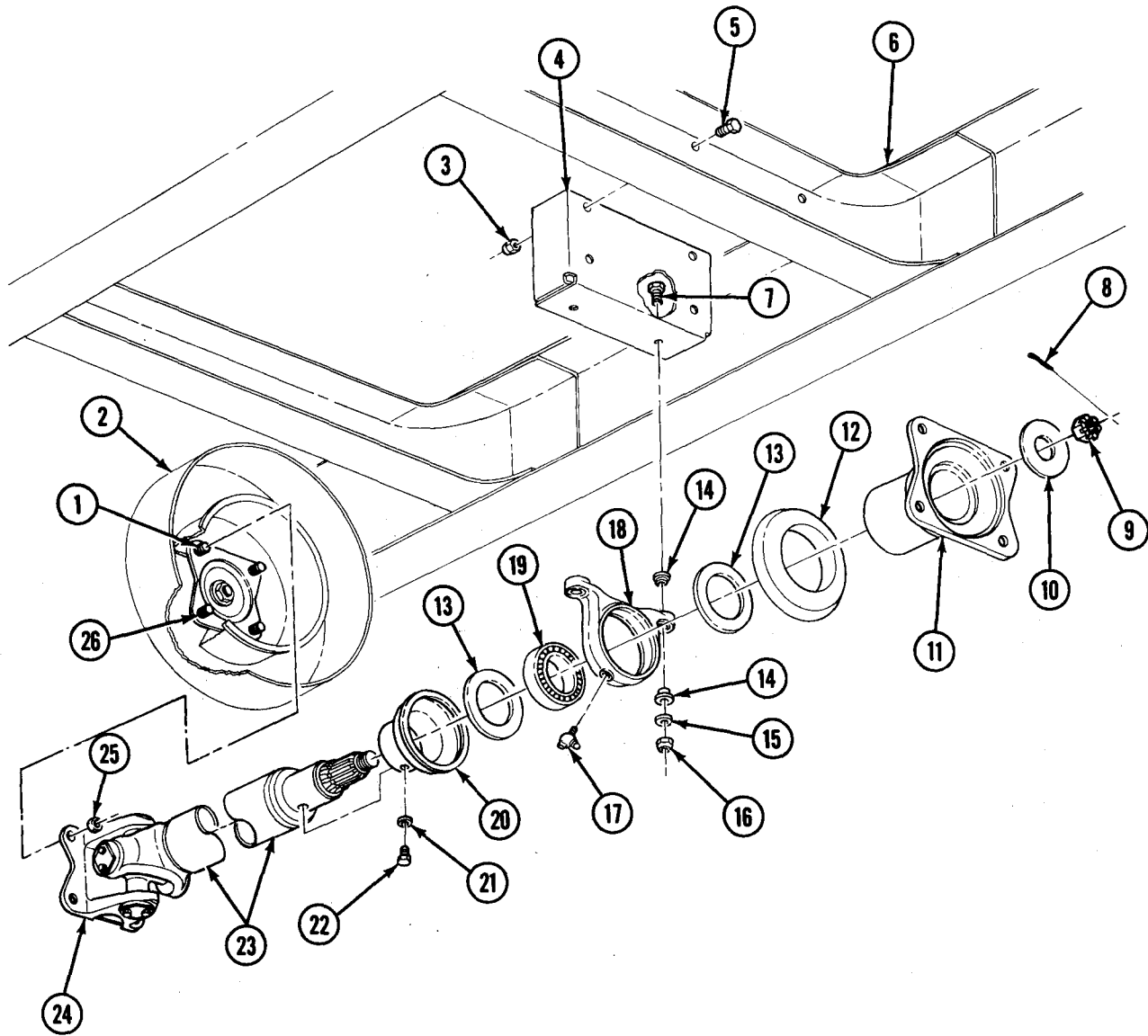

### 7-3. INTERMEDIATE PROPELLER SHAFT MAINTENANCE (M36A2) (Contd)

#### c. Cleaning and Inspection

#### **WARNING**

Drycleaning solvent is flammable and will not be used near open flame. Use only in well-ventilated places. Failure to do so may result in injury to personnel.

1. Clean and inspect bearing (20) in accordance with TM 9-214.
2. Inspect universal joint (25) for roughness and free play. Replace universal joint (25) if loose or rough (para. 7-4).
3. Clean all parts with drycleaning solvent and dry with clean rag.
4. Inspect propeller shaft (24) for:
  - a. Breaks, cracks, or bends. Replace if cracked, bent, or broken.
  - b. Crossed or stripped threads. Replace if threads are crossed or stripped.
  - c. Nicked or burred splines (28). Replace if splines are cracked or chipped.
  - d. Bearing shoulder nicked, burred, or scored. Replace if bearing shoulder is nicked, burred, scored, or bearing (20) is frozen.
5. Inspect shield (21) for cracks, breaks, or bends. Replace shield (21) if cracked, broken, or bent.
6. Inspect flange (11) for cracks, breaks, and bent deflector (12). Replace flange (11) if damaged.
7. Inspect rubber insulators (14) for tears or breaks. Replace rubber insulators (14) if torn or broken.
8. Inspect bearing housing (18) for cracks and breaks. Replace bearing housing (18) if cracked or broken.
9. Inspect frame support (4) for breaks and cracks. Replace frame support (4) if broken or cracked.

#### d. Assembly

1. Apply a light film of GAA grease to bearing (20) outer race and inner bore (17) of bearing housing (18). Install bearing (20) in bore (17). Ensure bearing (20) is seated square in bore (17) of bearing housing (18).
2. Install two new seals (13) in shaft side of bearing housing (18).
3. Slide shield (21) on shaft (24) as far as it will go.
4. Install shield (21) with screw (23) and new lockwasher (22).
5. Install four rubber insulators (14) in bearing housing (18).

#### **NOTE**

Perform step 6 if lubrication fitting was removed.

6. Install lubrication fitting (19) in bearing housing (18).

#### e. Installation

1. Install frame support (4) to crossmember (6) with four screws (5) and new locknuts (3).
2. Install flange yoke (26) on studs (1) of transfer flange (29) in parking brakedrum (2) with four new locknuts (27). Ensure scribed marks aline. Tighten locknuts (27) 90-120 lb-ft (122-163 NŹm).
3. Install bearing housing (18) to frame support (4) with two screws (7), washers (15), and new locknuts (16).
4. Install deflector (12) and flange (11) on shaft (24) with washer (10) and nut (9).
5. Tighten nut (9) on shaft (24) 260-290 lb-ft (353-393 NŹm).
6. Install new cotter pin (8) through nut (9).
7. Ensure shaft (24) turns freely and with no side play at U-joint (25) and support bearing (20).

7-3. INTERMEDIATE PROPELLER SHAFT Maintenance (M36A2) (Contd)

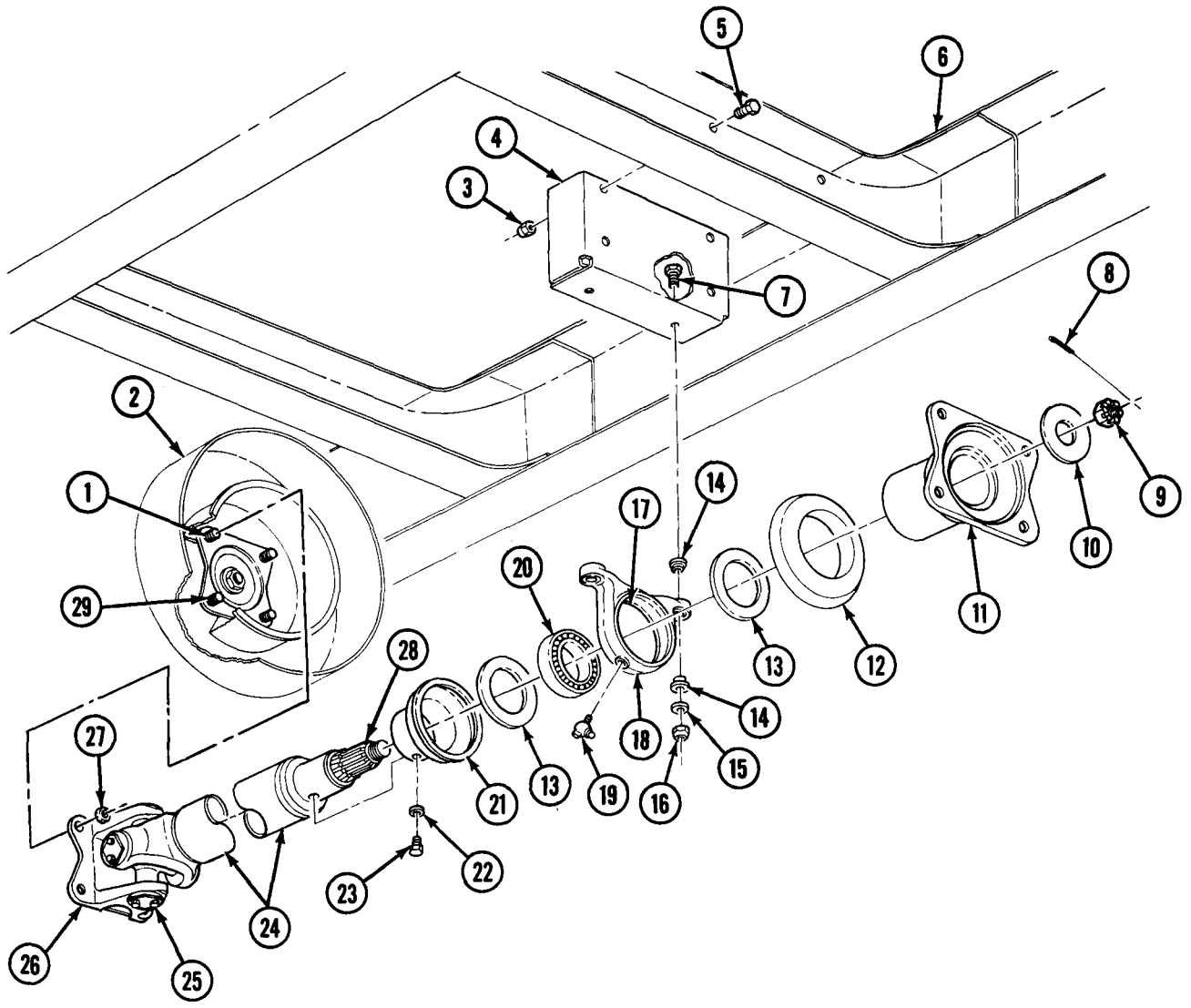

FOLLOW-ON TASKS: • Install forward-rear propeller shaft (para. 7-2).  
 • Lubricate bearing housing (LO 9-2320-209-12-1).



**7-4. UNIVERSAL JOINT MAINTENANCE**

This task covers:

- a. Disassembly
- b. Cleaning and Inspection
- c. Assembly

INITIAL SETUP:

APPLICABLE MODELS

All

MATERIALS/PARTS

Four snaprings or C-rings

GAA grease (Appendix C, Item 13)  
 Drycleaning solvent (Appendix C, Item 26)  
 Rags (Appendix C, Item 21)

REFERENCES (TM)

TM 9-2320-361-20P  
 TM 9-2320-209-12  
 TM 9-214

EQUIPMENT CONDITION

- Propeller shaft removed (para. 7-2).
- Intermediate propeller shaft removed (M36A2) (para. 7-3).

GENERAL SAFETY INSTRUCTIONS

Keep fire extinguisher nearby when using drycleaning solvent.

**NOTE**

- Do not remove bearings from caps, except when replacing caps.
- Mark mating yoke position for installation.

**a. Disassembly**

1. C-ring and snapring type:

- a. Remove four snaprings (1) from yoke (6) and yoke flange (4) or four C-rings (3) from spider cross (6). Discard snaprings (1) or C-rings (3).
- b. Remove four bearing caps (2), yoke flange (4), and spider cross (5) from yoke (6).
- c. Remove four seals (7) and lubrication fitting (8) from spider cross (5). Discard seals (7).

2. Cap type:

- a. Remove eight screws (9), four straps (10), and bearing caps (11) from yoke (13) and yoke flange (12).
- b. Remove yoke flange (12) and spider cross (5) from yoke (13).
- c. Remove four seals (7) and lubrication fitting (8) from spider cross (5). Discard seals (7).

7-4. UNIVERSAL JOINT MAINTENANCE (Contd)

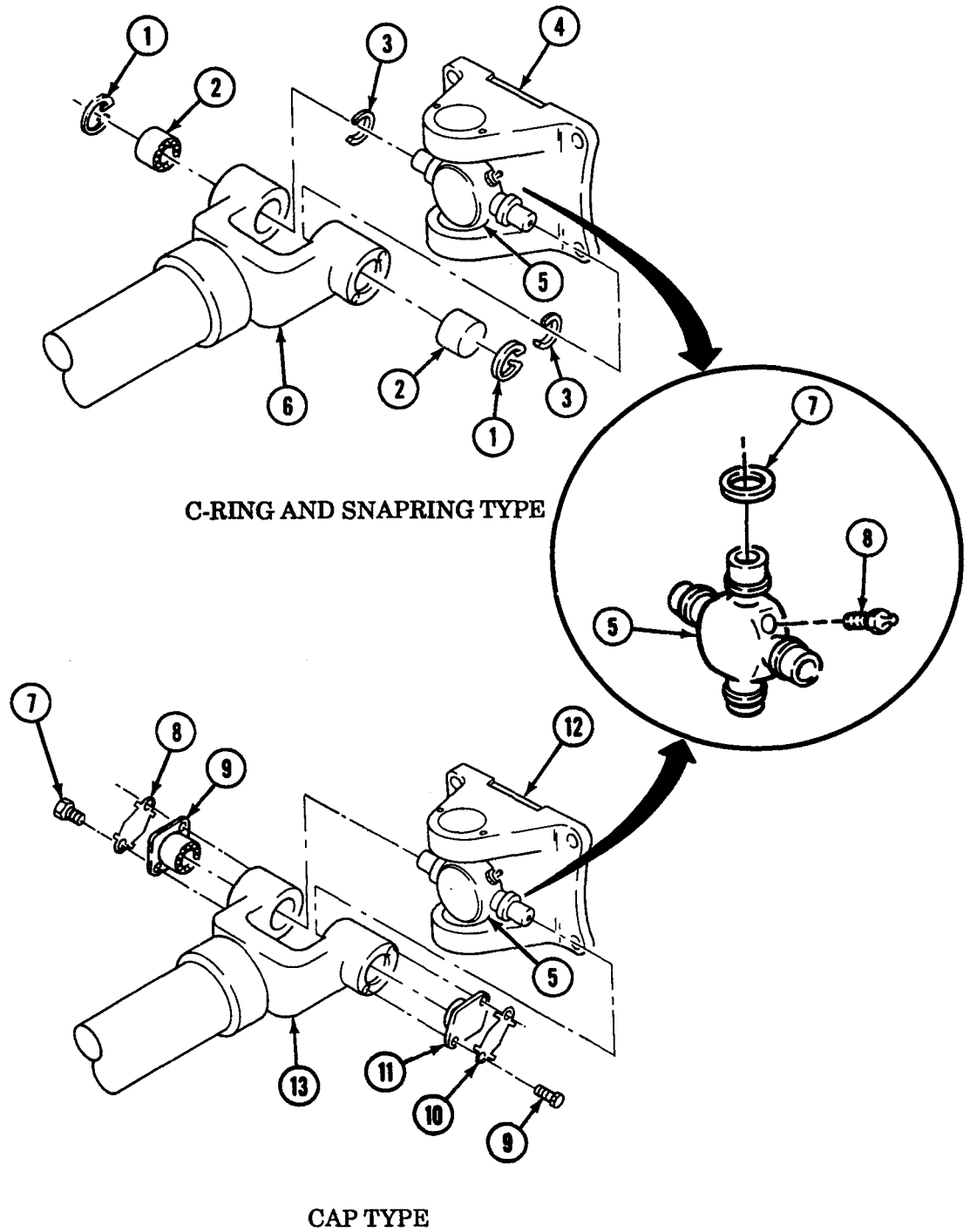

**7-4. UNIVERSAL JOINT MAINTENANCE (Contd)**

**b. Cleaning and Inspection**

**WARNING**

Drycleaning solvent is flammable and will not be used near open flame. Use only in well-ventilated places. Failure to do so may result in injury to personnel.

1. Clean all parts with drycleaning solvent and dry with clean rag.
2. Inspect yokes (2) for breaks, cracks, and bends. Replace yokes (2) if damaged.
3. Inspect snapping grooves (1) for damage. Replace yoke flange (10) or yoke (2) if damaged.
4. Inspect shafts (3) for bends, cracks, damaged threads (5), and splines (4). Replace shaft (3) if damaged.
5. Inspect bearings (6) in bearing cap (2) (TM 9-214). Replace U-joint if damaged.

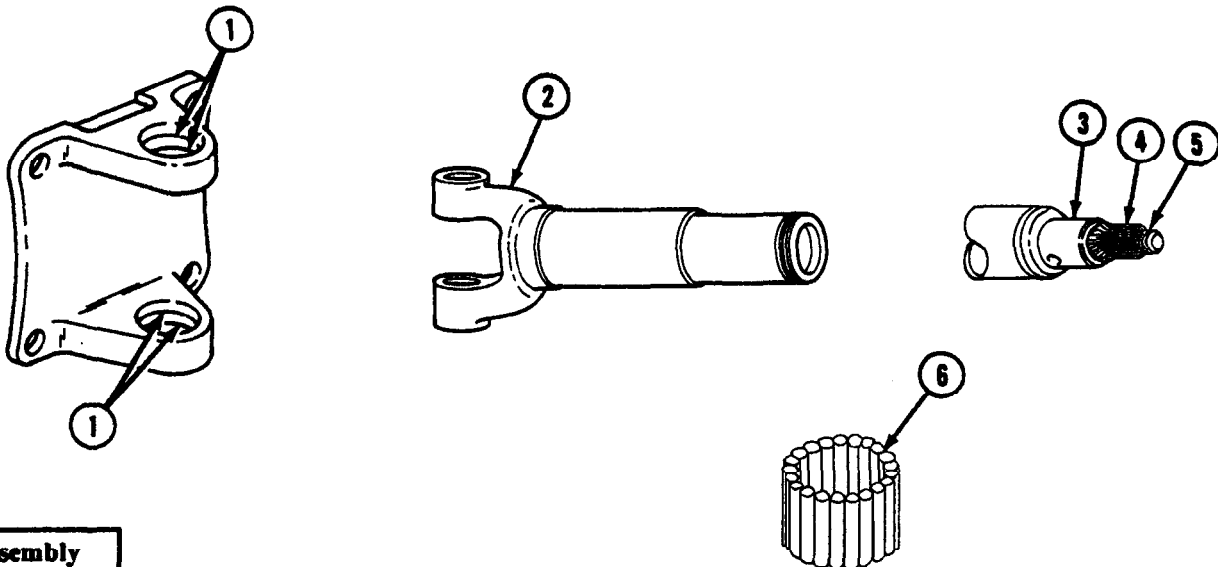

**c. Assembly**

1. C-ring and snapping type:
  - a. Apply thick film of GM grease to bearing caps (7) to hold bearings (6) in place during assembly.
  - b. Install four new rubber seals (13) on spider cross journals (14).
  - c. Install spider cross journals (14) in yoke flange (10). Press two bearing caps (7) into yoke flange loops (11).
  - d. Ensure C-ring grooves (12) of both bearing caps (7) are visible under yoke flange (10) and install two new C-rings (8) in grooves (12) of two bearing caps (7).
  - e. Ensure snapping groove (1) in outside edge of both yoke loops (11) are visible. Install two new snaprings (16).

**NOTE**

Align marks on yokes before assembling bearing caps in shaft yoke.

- f. Position yoke (2) on spider cross journals (14), and install two bearing Caps (7), new snaprings (16), or C-rings (8).
- g. Install lubrication fitting (15) on spider cross (9).

7-4. UNIVERSAL JOINT MAINTENANCE (Contd)

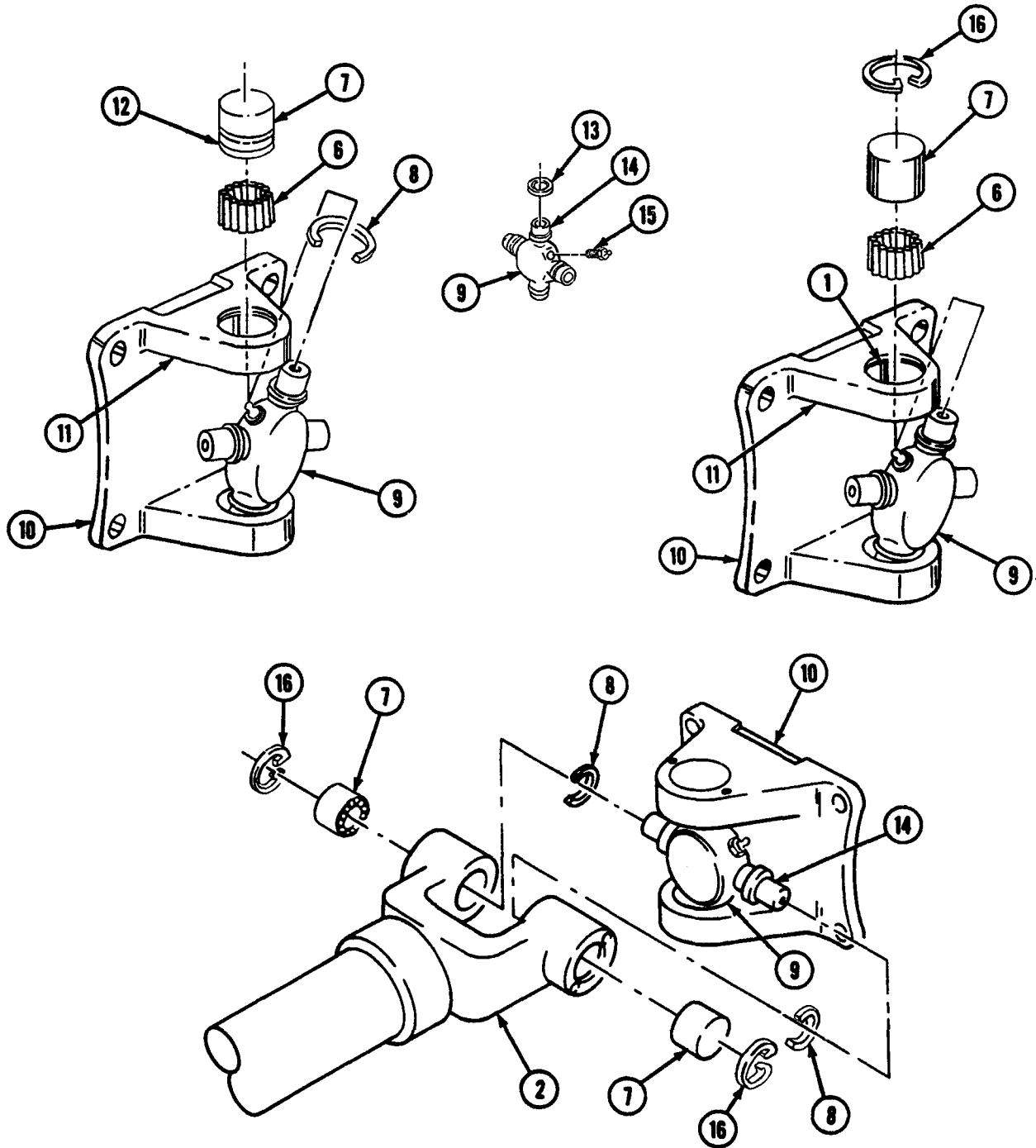

C-RING AND SNAPRING TYPE

**7-4. UNIVERSAL JOINT MAINTENANCE (Contd)**

**NOTE**

Aline marks on yokes before assembling bearing caps in shaft yoke.

2. cap type:

- a. Install four new seals (8) on spider cross journals (9).
- b. Install lubrication fitting (10) on spider cross (7).
- c. Install spider cross (7) in upper yoke flange loop (5) with lubrication fitting (10) angled away from yoke flange (6).
- d. Apply GM grease in bearing caps (3) to hold bearing (4) in place during assembly.
- e. Install two bearing caps (3) on spider cross journal (9) and upper yoke flange loop (5).
- f. Position two locking straps (2) on bearing caps (3) and install with four screws (1). Tighten screws (1) 18-25 lb-ft (24-34 NZm). Bend tabs of locking straps (2) up to hold screws (1) in place.

**NOTE**

Aline marks on yokes before assembling bearing caps in shaft yoke.

- g. Position shaft yoke (11) on spider cross journals (9) and install two bearing caps (3) with new locking straps (2) and four screws (1). Tighten screws (1) 18-25 lb-ft (24-34 NZm).
- h. Bend tabs of locking straps (2) up to hold screws (1) in place.
- i. Shaft yokes (11) and yoke flange (6) should move smoothly and have no free play.

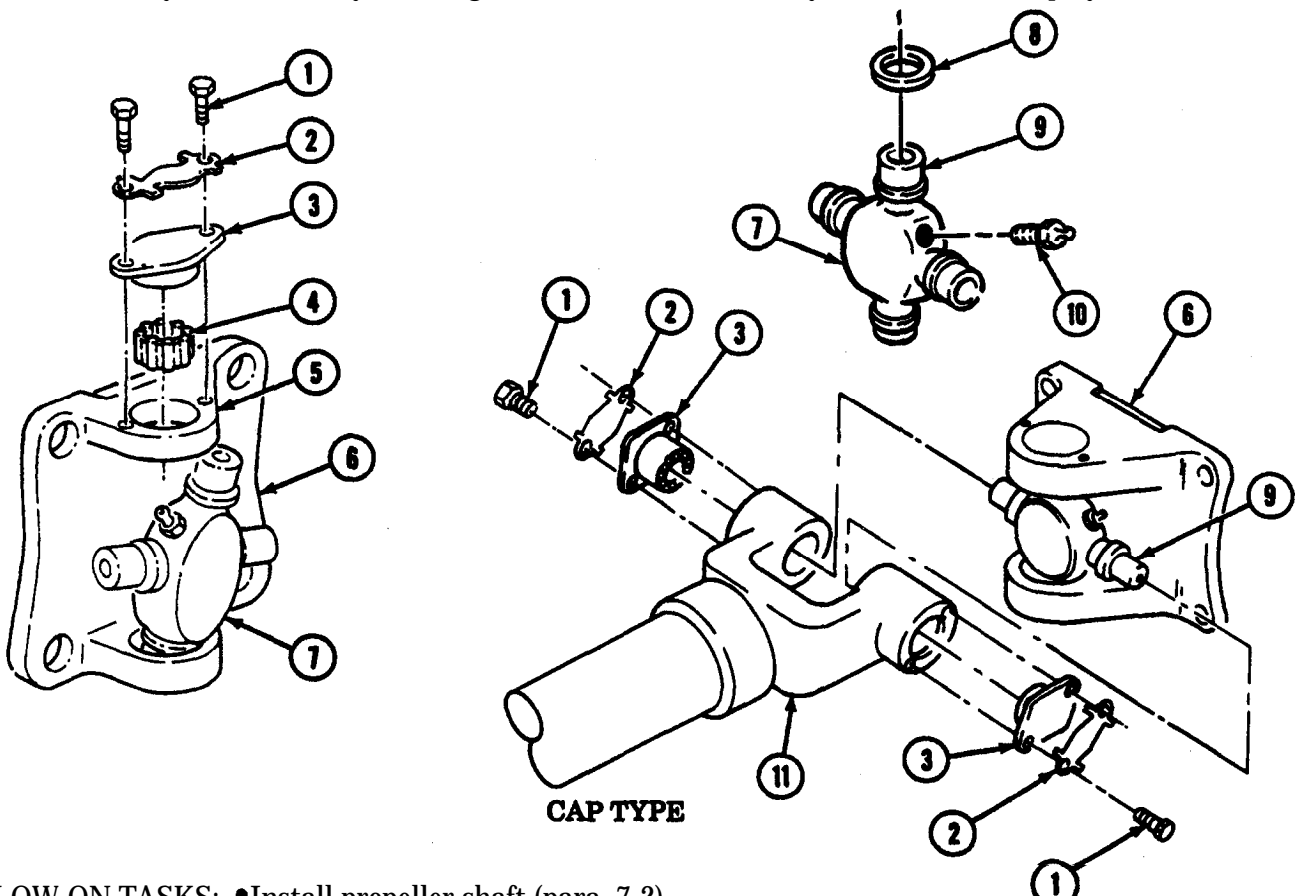

FOLLOW-ON TASKS: •Install propeller shaft (para. 7-2).  
 •Install intermediate propeller shaft (M36A2) (para. 7-3).

## Section II. FRONT AND REAR AXLE MAINTENANCE

## 7-5. FRONT AND REAR AXLE MAINTENANCE INDEX

PARA. NO.	TITLE	PAGE NO.
7-6.	Front Axle Shaft and Universal Joint Maintenance	7-15
7-7	Front Axle Oil Seal Assembly Replacement	7-20
7-8.	Front and Rear Axle Breather Maintenance	7-21
7-9.	Steering Knuckle Boot Replacement	7-22
7-10.	Front Axle Shaft Flange Maintenance	7-24
7-11.	Rear Axle Shaft Maintenance	7-26

## 7-6. FRONT AXLE SHAFT AND UNIVERSAL JOINT MAINTENANCE

This task covers:

- |                            |                 |
|----------------------------|-----------------|
| a. Removal                 | c. Installation |
| b. Cleaning and Inspection |                 |

## INITIAL SETUP:

APPLICABLE MODELS

All

MATERIALS/PARTS

Twelve lockwashers  
 Seal assembly  
 Two washers  
 GO 80/90 oil (Appendix C, Item 17)  
 Drycleaning solvent (Appendix C, Item 26)  
 Rags (Appendix C, Item 21)  
 Sealing compound (Appendix C, Item 25)  
 Cap and plug set (Appendix C, Item 8)

REFERENCES (TM)

LO 9-2320-209 -12-1  
 TM 9-2320-361-20P

EQUIPMENT CONDITION

Front hubs and drums removed (para. 9-3).

GENERAL SAFETY INSTRUCTIONS

Keep fire extinguisher nearby when using drycleaning solvent.

**7-6. FRONT AXLE SHAFT AND UNIVERSAL JOINT MAINTENANCE (Contd)**

**CAUTION**

Plug all openings after disconnection to prevent contamination.

**NOTE**

- Left and right side front axle shafts are replaced the same way. This procedure covers the right side front axle shaft.
- Have drainage container ready to catch brake fluid.

1. Remove screw (2), two washers (3), and hose connector (4) from wheel cylinder (1). Discard washers (3).
2. Remove spring (10) from brakeshoes (5)
3. Remove twelve nuts (9), lockwashers (8), and deflector (7) from brake plate (6). Discard lockwashers (8).
4. Remove brake plate (6) from spindle (11).
5. Slide spindle (11) and thin thrust washer (12) off outer shaft of front axle shaft (16).
6. Carefully pull front axle shaft (16) out of axle housing (15) and steering knuckle (14).
7. Remove thick thrust washer (13) from front axle shaft (16).

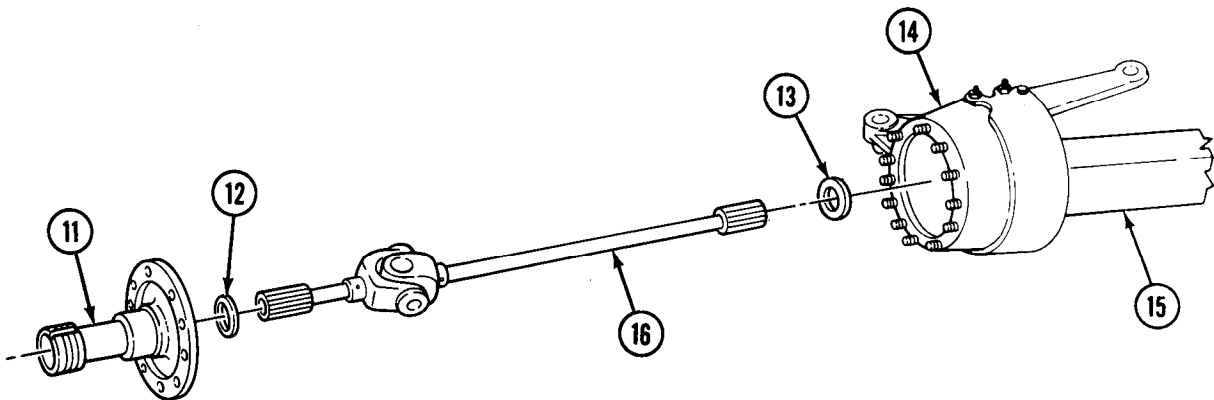
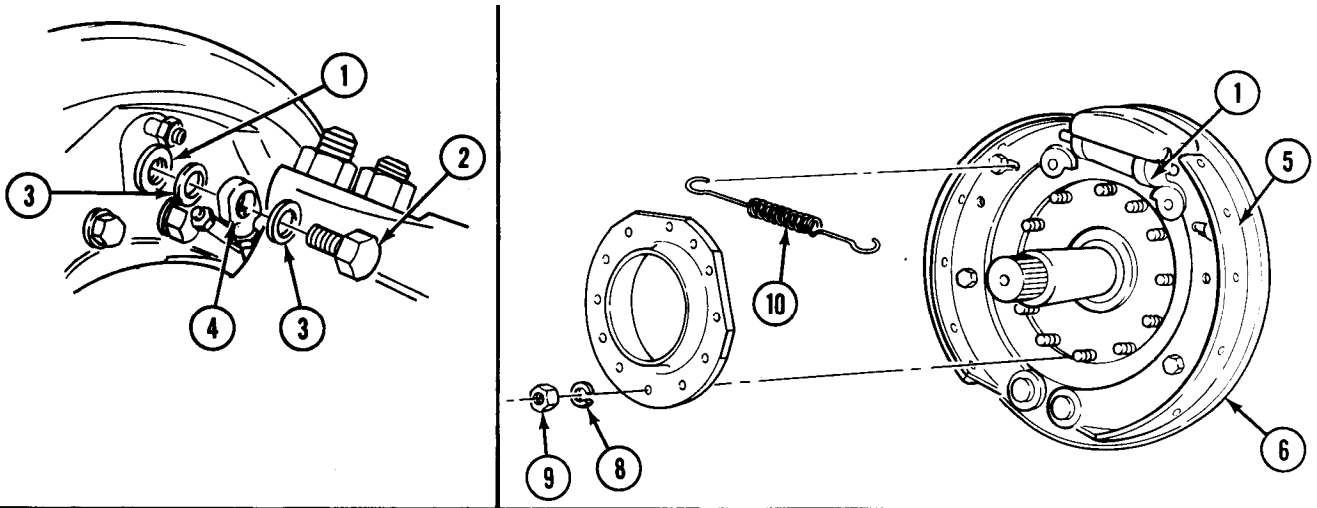

**7-6. FRONT AXLE SHAFT AND UNIVERSAL JOINT MAINTENANCE (Contd)**

**b. Cleaning and Inspection**

1. Inspect for worn U-joint as follows:
  - a. Place short shaft (19) in vise (20) and twist shaft (17) back and forth checking for free play.
  - b. Push and pull shaft (17) and check for free play.
  - c. Check universal joint (18) for roughness, binding, or free play. Replace universal joint (18) if damaged (para. 7-4).

**WARNING**

Drycleaning solvent is flammable and will not be used near open flame. Use only in well-ventilated places. Failure to do so may result in injury to personnel.

2. Clean all metal parts with rag saturated with drycleaning solvent. Do not clean brake lining or any parts of wheel cylinder with drycleaning solvent. Clean sealer remains from mating surfaces.
3. Inspect shafts (17) and (19), including yokes (27), for breaks, cracks, or bends. Replace shafts (17) or (19) if damaged.
4. Inspect splines (25) and (26) for nicks, burrs, or chipping. Replace shafts (17) or (19) if nicked, burred, or chipped.
5. Inspect thrust washers (12) and (13) for evidence of overheating (discoloration) or scoring. Replace thrust washers (12) and (13) if discolored or scored.
6. Inspect spindle (11) bearing sleeve (21), and bearing surfaces (22) and (23) for scoring. Replace spindle (11) if scored.
7. Inspect studs (24) of steering knuckle (14) for stripped or crossed threads. Replace studs (24) if threads are stripped or crossed.

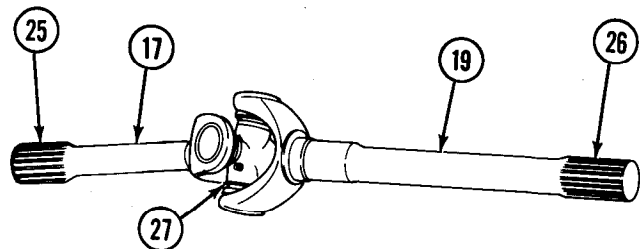
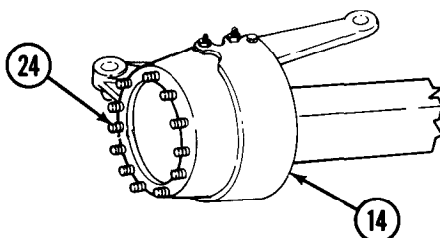
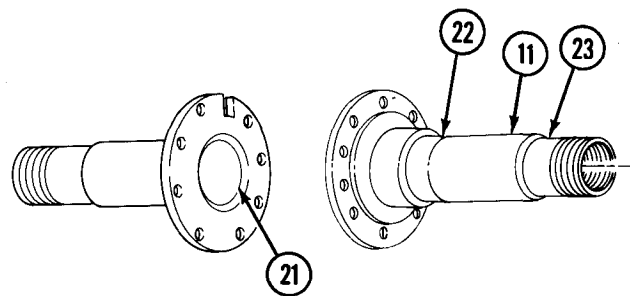
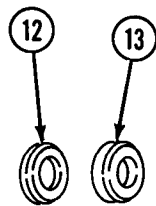
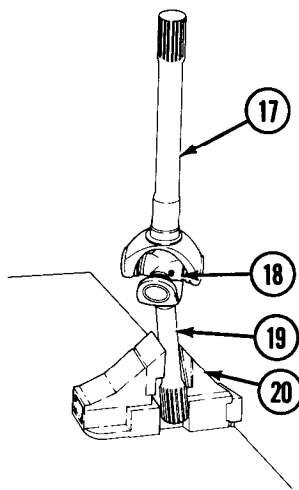



## 7-6. FRONT AXLE SHAFT AND UNIVERSAL JOINT MAINTENANCE (Contd)

### c. Installation

1. Lubricate U-joint (5) (LO 9-2320-209-12-1). Coat splines (3) and (6) with GO 80/90 oil.
2. Install thick thrust washer (7) on shaft (10) with tapered side of thrust washer (7) toward U-joint (5).
3. Carefully slide axle shaft (10) into axle housing (9) and seat splines (6) in differential.
4. Install thin thrust washer (2) on shaft (4) with tapered side of thrust washer (2) toward U-joint (5).
5. Run 1/8 in. x 1/8 in. (3.2 mm x 3.2 mm) bead of sealing compound on inside surface of deflector (15) just inside of stud circle.
6. Apply sealing compound on studs (14).
7. Install spindle (1) on shaft (4) and seat on studs (14) of knuckle (8).
8. Install brake plate (13) and deflector (15) on spindle (1) and studs (14) of knuckle (8) with twelve new lockwashers (16) and nuts (17). Tighten nuts (17) 25-35 lb-ft (34-48 NŹm).
9. Install spring, (11) on brakeshoe (12).
10. Install hose connector (19) on back of wheel cylinder (18) with two new washers (21) and screw (20).

7-6. FRONT AXLE SHAFT AND UNIVERSAL JOINT MAINTENANCE (Contd)

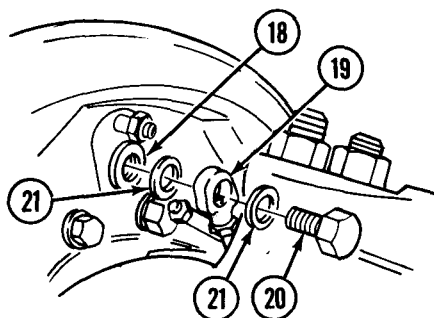
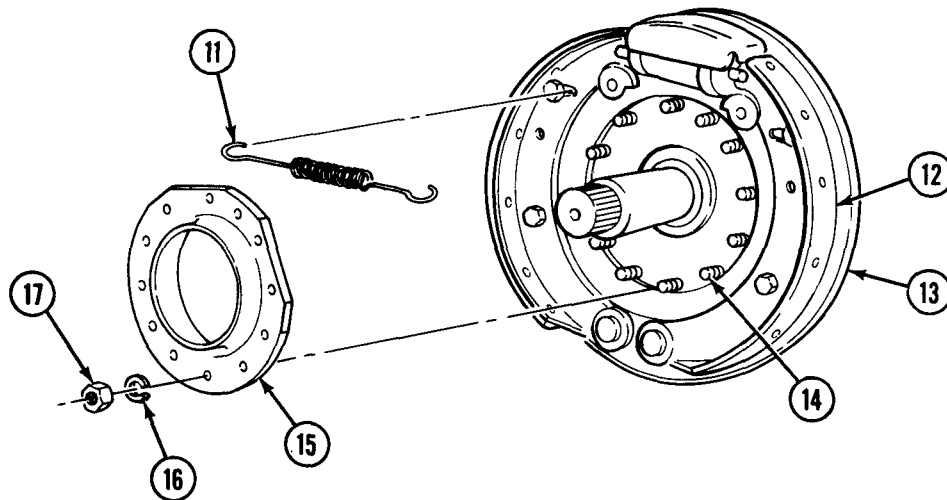
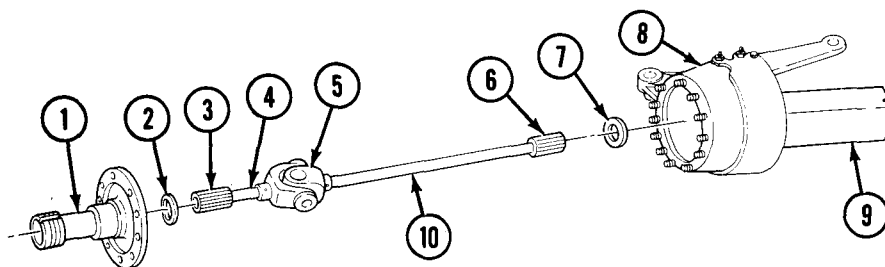

FOLLOW-ON TASKS: •Bleed front brakes (para. 8-12).  
 •Install front hubs and drums (para. 9-3).

**7-7. FRONT AXLE OIL SEAL ASSEMBLY REPLACEMENT**

This task covers:

**a. Removal**

**b. Installation**

**INITIAL SETUP**

APPLICABLE MODELS

All

REFERENCES (TM)

TM 9-2320-361-20P

SPECIAL TOOLS

Puller, mechanical,

PN 8708740

Insertor, oil seal and retainer,

PN 7083258

MATERIALS/PARTS

Oil seal assembly

EQUIPMENT CONDITION

Front axle shaft removed (para. 7-6).

Using mechanical puller, remove oil seal assembly (1) from axle housing (2). Discard oil seal assembly (1).

**b. Installation**

Using oil seal inserter, install new oil seal assembly (1) in axle housing (2).

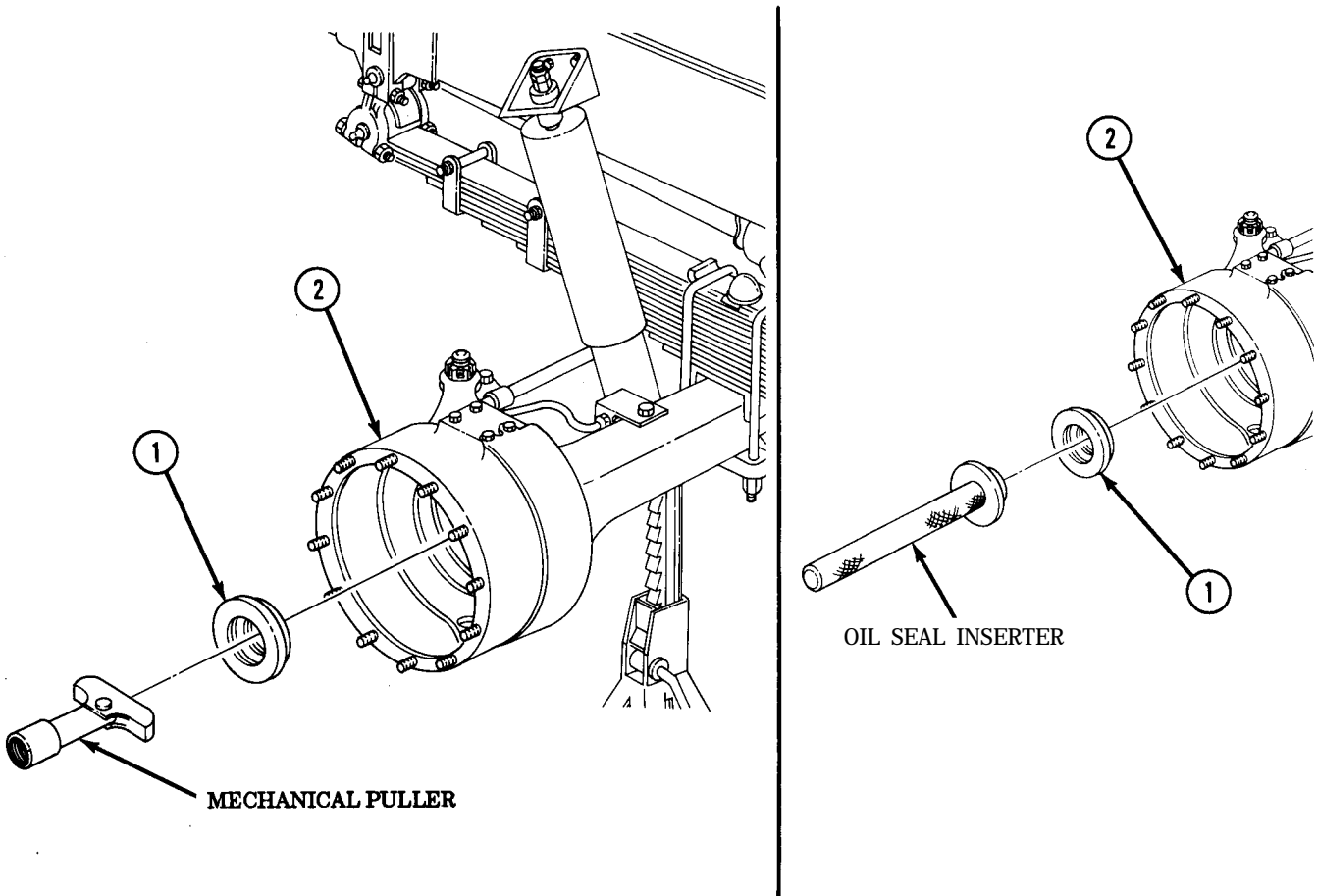

FOLLOW-ON TASK: Install front axle shaft (para. 7-6).

## 7-8. FRONT AND REAR AXLE BREATHER MAINTENANCE

This task covers:

- a. Removal
- b. Cleaning

- c. Installation

### INITIAL SETUP:

#### APPLICABLE MODELS

All

#### MATERIALS/PARTS

Drycleaning solvent (Appendix C, Item 26)

Rags (Appendix C, Item 21)

#### REFERENCES (TM)

TM 9-2320-361-10

TM 9-2320-361-20P

#### EQUIPMENT CONDITION

Parking brake set (TM 9-2320-361-10).

#### GENERAL SAFETY INSTRUCTIONS

Keep fire extinguisher nearby when using drycleaning solvent.

### a. Removal

#### **NOTE**

This procedure is for all axles.

Remove breather (1) from axle housing (2).

### b. Cleaning

#### **WARNING**

Drycleaning solvent is flammable and will not be used near open flame. Use only in well-ventilated places. Failure to do so may result in injury to personnel.

Clean breather (1) in drycleaning solvent and dry with clean rag.

### c. Installation

Install breather (1) in axle housing (2).

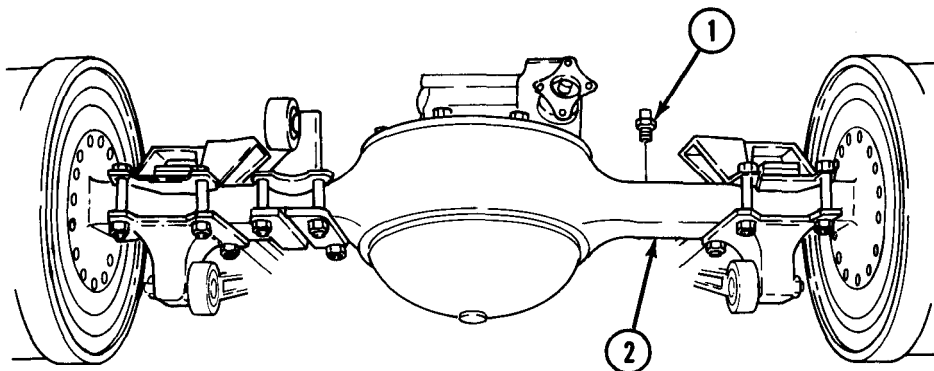

**7-9. STEERING KNUCKLE BOOT REPLACEMENT**

This task covers:

**a. Removal**

**b. Installation**

INITIAL SETUP:

APPLICABLE MODELS

All

REFERENCES (TM)

TM 9-2320-361-10

TM 9-2320-361-20P

MATERIALS/PARTS

Four lockwashers

Steering knuckle, dust boot parts kit  
(PIN 7410883)

Adhesive (Appendix C, Item 4)

EQUIPMENT CONDITION

Parking brake set (TM 9-2320-361-10).

**a. Removal**

**NOTE**

Left and right steering knuckle boots are replaced the same way. This procedure covers the left side.

1. Remove four screws (1), lockwashers (2), and boot guard (3) from steering arm (4) and knuckle (5). Discard lockwashers (2).
2. Hold nut (7) and loosen screw (6) on outer clamp (8).
3. Remove outer clamp (8) and slide boot (11) off toward center of vehicle.
4. Pull boot (11) off steering knuckle (5).
5. Hold nut (13), loosen screw (12), and slide inner clamp (14) off boot (11) toward center of vehicle.
6. Pull boot (11) away from axle housing (17).

**NOTE**

Cut boot only if necessary for removal. Replacement boots are equipped with zippers.

7. Cut boot (11) from edge (15) to (16). Remove and discard boot (11).

**b. Installation**

**NOTE**

When boot is properly installed, zipper will be toward fronton left side and toward rear on right side.

1. Place new boot (11) around axle housing (17) so that when zipped up, zipper tab (9) is outside of boot (11).
2. Close zipper (10) all the way.
3. Thoroughly coat zipper (10) with adhesive sealer.

**NOTE**

Ensure word TOP is facing upward when installing boot.

4. Place small end of boot (11) over groove in axle housing (17) and slide small clamp (14) over boot (11) until fully seated in groove of axle housing (17). Screw (12), nut (13), and clamp (14) must be positioned on top of axle housing (17), and clamp (14) must be between two beads of boot (11).
5. While holding nut (13), tighten screw (12) of clamp (14). Check that clamp (14) is holding boot (11) in groove of axle housing (17).

**7-9. STEERING KNUCKLE BOOT REPLACEMENT (Contd)**

6. Fold free inner edge of boot (11) over itself and place over groove in steering knuckle (5). Tab (9) of zipper (10) is now inside of boot (11).

**NOTE**

When steering knuckle boot clamp is installed, ensure screw and nut are located toward front and at top of steering knuckle when tightened.

7. Slide larger clamp (8) over boot (11) and seat clamp (8) in groove of steering knuckle (5). Ensure clamp (8) is seated all the way around steering knuckle (5) and is between two beads of boot (11).
8. While holding nut (7), tighten screw (6) of clamp (8).
9. Bend two screws (6) and (12) to prevent loosening.
10. Using adhesive sealer, seal around both edges of boot (11) to steering knuckle (5) and axle housing tube (17).
11. Install boot guard (3) on steering arm (4) and steering knuckle (5) with four new lockwashers (2) and screws (1).

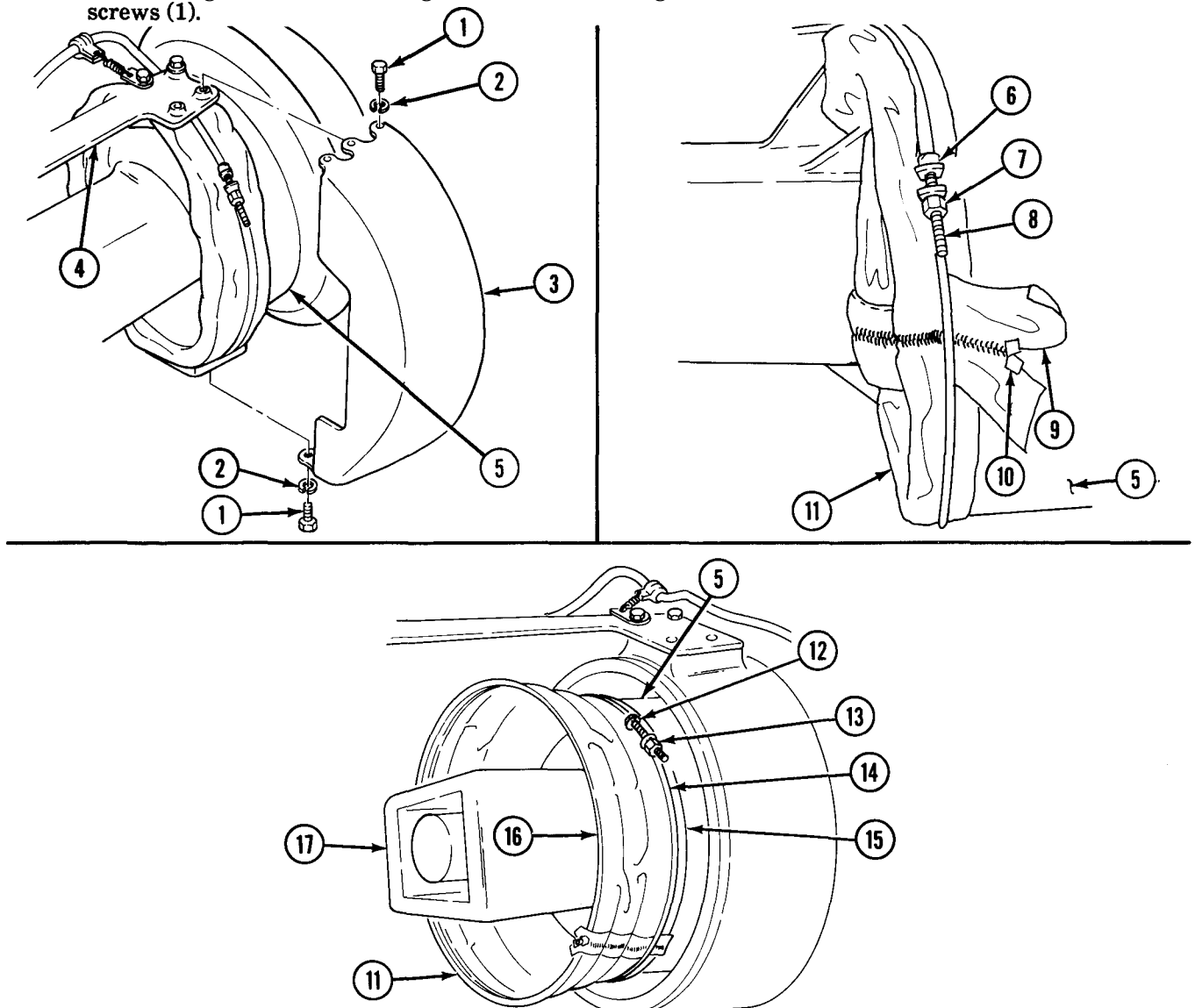

**7-10. FRONT AXLE SHAFT FLANGE MAINTENANCE**

This task covers:

- a. Removal
- b. Cleaning and Inspection

c. Installation

**INITIAL SETUP:**

APPLICABLE MODELS

All

MATERIALS/PARTS

- Gasket
- Eight lockwashers
- GAA grease (Appendix C, Item 13)
- Drycleaning solvent (Appendix C, Item 26)
- Rags (Appendix C, Item 21)

REFERENCES (TM)

- TM 9-2320-361-10
- TM 9-2320-361-20P

EQUIPMENT CONDITION

Parking brake set (TM 9-2320-361-10).

GENERAL SAFETY INSTRUCTIONS

Keep fire extinguisher nearby when using drycleaning solvent.

**a. Removal**

1. Remove eight screws (1) and lockwashers (2) from axle flange (3) and hub (5). Discard lockwashers (2).
2. Loosen axle flange (3) from axle shaft (6).
3. Remove axle flange (3) and gasket (4). Discard gasket (4).

**b. Cleaning and Inspection**

1. Clean gasket (4) remains from mating surfaces.

**WARNING**

Drycleaning solvent is flammable and will not be used near open flame. Use only in well-ventilated places. Failure to do so may result in injury to personnel.

2. Clean axle flange (3) in drycleaning solvent and dry with clean rag.
3. Clean gasket (4) surface on hub (5) with rag saturated with drycleaning solvent and dry with clean rag.
4. Inspect axle flange (3) for:
  - a. Cracks and breaks. Replace if cracked or broken.
  - b. Nicked, burred, or cracked female splines. Remove minor nicks or burrs with fine mill file or emery cloth, Replace if splines are cracked.
  - c. Inspect plug (7) for tightness. Replace if loose or leaking lubricant.
5. Inspect male splines on axle shaft (6) for nicks, burrs, or cracks. Remove minor nicks or burrs with fine mill file or emery cloth. Replace axle shaft if splines are cracked (para. 7-6).

**7-10. FRONT AXLE SHAFT FLANGE MAINTENANCE (Contd)****c. Installation**

1. Coat one side of new gasket (4) with GAA grease and align over holes in hub (5).
2. Align holes in axle flange (3), gasket (4), and hub (5), and install with eight new lockwashers (2) and screws (1). Tighten 60-80 lb-ft (81-108 N $\cdot$ m).

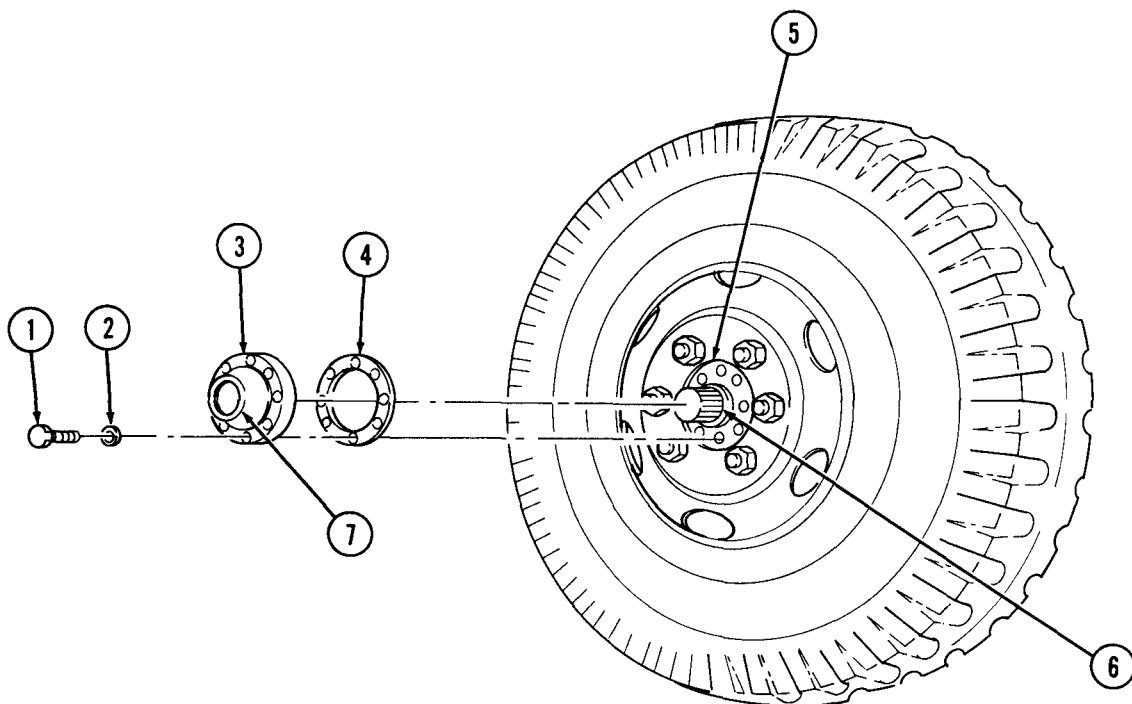



**7-11. REAR AXLE SHAFT MAINTENANCE**

This task covers:

- a. Removal
- b. Cleaning and Inspection

- c. Installation

**INITIAL SETUP:**

APPLICABLE MODELS

All

MATERIALS/PARTS

- Gaskets
- Eight lockwashers
- GAA grease (Appendix C, Item 13)
- Rags (Appendix C, Item 21)
- Drycleaning solvent (Appendix C, Item 26)

REFERENCES (TM)

- TM 9-2320-361-10
- TM 9-2320-361-20P

EQUIPMENT CONDITION

Parking brake set (TM 9-2320-361-10).

GENERAL SAFETY INSTRUCTIONS

Keep fire extinguisher nearby when using drycleaning solvent.

**a. Removal**

1. Remove eight screws (1) and lockwashers (2) from flange (3) and hub (6). Discard lockwashers (2).
2. Remove flange (3), axle shaft (4) as an assembly, and gasket (5) from hub (6) and axle housing (7). Discard gasket (5).

**b. Cleaning and Inspection**

**WARNING**

Drycleaning solvent is flammable and will not be used near open flame. Use only in well-ventilated places. Failure to do so may result in injury to personnel.

1. Clean gasket (5) remains from mating surfaces.
2. Clean axle shaft (4) with rag saturated in drycleaning solvent. Dry with clean rag,
3. Inspect axle shaft (4) for cracks, breaks, and bends. Replace axle shaft (4) if cracked, broken, or bent.
4. Inspect axle shaft (4) splines for nicks, burrs, cracks, and breaks. Remove minor nicks and burrs with a fine mill file or emery cloth. Replace if splines are cracked or broken.

**c. Installation**

1. Coat one side of new gasket (5) with GAA grease and align over holes in hub (6).
2. Carefully insert axle shaft (4) into hub (6) and axle housing (7). Turn until splines of axle shaft (4) seat in differential. Align holes of flange (3) to holes in gasket (5) and hub (6).
3. Install flange (3) with eight new lockwashers (2) and screws (1). Tighten screws (1) 60-80 lb-ft (81-108 N·m).

7-11. REAR AXLE SHAFT MAINTENANCE (Contd)

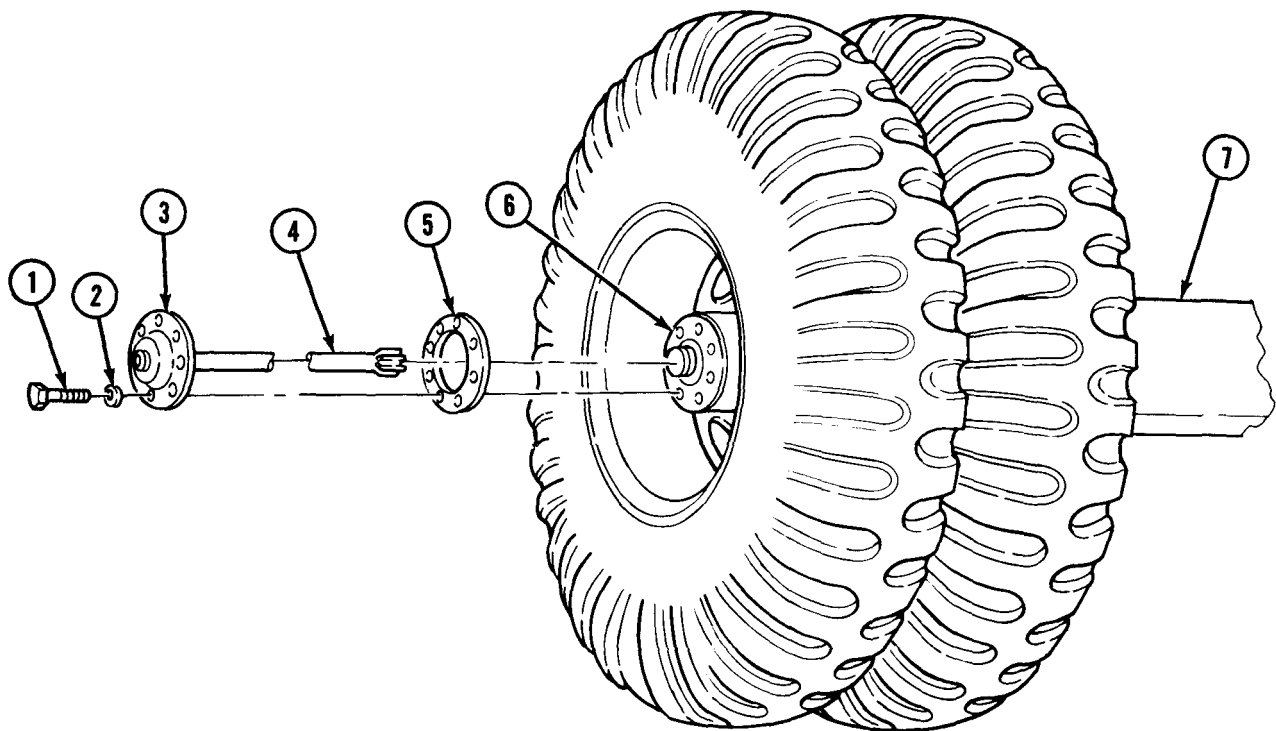

Section III. FRONT AND REAR SUSPENSION MAINTENANCE

**7-12. FRONT AND REAR SUSPENSION MAINTENANCE INDEX**

PARA. NO.	TITLE	PAGE NO.
7-13.	Front Spring Replacement	7-28
7-14.	Front Spring Shackle Replacement	7-32
7-15.	Front Spring Bumper Replacement	7-34
7-16.	Front Spring Maintenance	7-36
7-17.	Rear Spring Replacement	7-40
7-18.	Rear Spring Maintenance	7-42
7-19.	Rear Spring Seat Replacement	7-44
7-20.	Shock Absorber Replacement	7-46
7-21.	Rear Spring Wear Pad Replacement	7-48
7-22.	Torque Rods Replacement	7-50

**7-13. FRONT SPRING REPLACEMENT**

This task covers:

**a. Removal**

**b. Installation**

INITIAL SETUP:

APPLICABLE MODELS

All

MATERIALS/PARTS

Four locknuts  
 Four lockwashers  
 Adhesive sealant (Appendix C, Item 5)

PERSONNEL REQUIRED

Two

REFERENCES (TM)

LO 9-2320-209-12-1  
 TM 9-2320-361-10  
 TM 9-2320-361-20P

EQUIPMENT CONDITION

- Parking brake set (TM 9-2320-361-10).
- Front right wheel removed (para. 9-2).

**a. Removal**

**NOTE**

Left and right front springs are replaced the same way. This procedure covers the right side.

1. Raise front of vehicle and remove two jack stands (11) from under front axle (12).
2. Support vehicle at frame (26) with two jack stands (11).
3. Place hydraulic jack (14) under front axle (12).
4. Remove jamnut (18), nut (19), retainer (20), and rubber bushing (21) from shock absorber piston rod (25).
5. Push shock absorber piston rod (25) up and out of plate (15).
6. Remove rubber bushing (23) and retainer (24) from piston rod (25).

**7-13. FRONT SPRING REPLACEMENT (Contd)**

7. Remove four nuts (17), lockwashers (16), and plate (15) from two U-bolts (8). Discard lockwashers (16).
8. Remove two U-bolts (8), saddle (9), and rubber bumper (10) from spring (2).
9. Remove four locknuts (3) and screws (6) from hanger (7) and shackle (1). Discard locknuts (3).
10. Remove two lubrication fittings (4) from two pins (5).

**NOTE**

Assistant will help with steps 11 through 15.

11. Remove two pins (5) from shackle (1), hanger (7), and spring (2).
12. Push shackle (1) toward front of vehicle.
13. Push spring (2) clear of rear hanger (7).
14. Lift spring (2) clear of spring seat (13) and remove from vehicle.
15. Remove spring seat (13) from centering peg (22) and front axle (12).

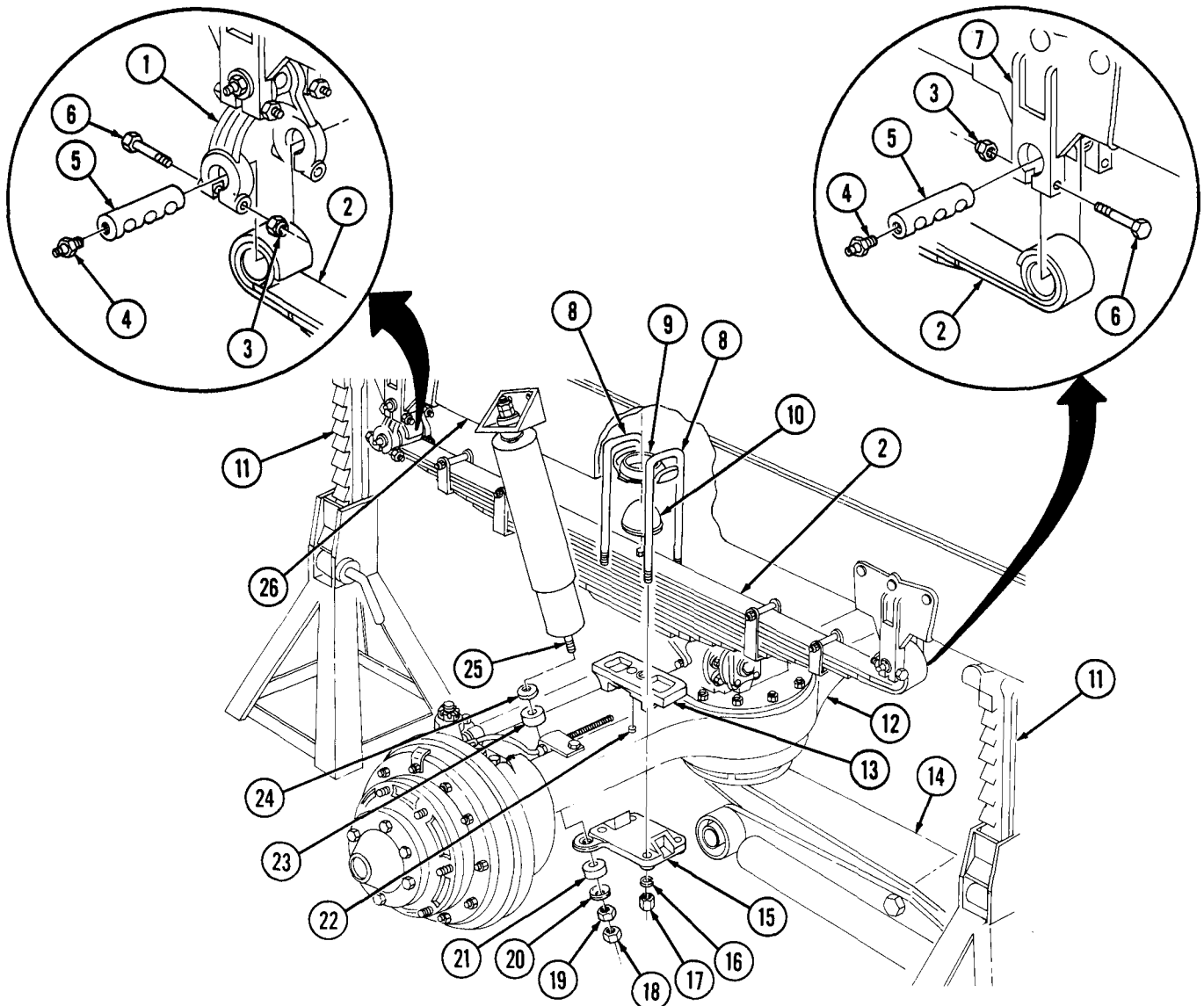

## 7-13. FRONT SPRING REPLACEMENT (Contd)

### NOTE

Assistant will help with steps 1 through 5.

1. Ensure spring seat (13) is properly positioned on centering peg (22) and front axle (12). Place spring (2) on spring seat (13) so nut on bottom of center bolt (26) is in spring seat (13).
2. Using hydraulic jack (14), raise or lower axle (12) to align holes in spring (2) with holes in shackle (1) and hanger (7).
3. Install spring (2) on shackle (1) and hanger (7) with two pins (5).
4. Turn pins (5) to align pin retaining screw slots with holes in shackle (1) and hanger (7).
5. Install four screws (6) and new locknuts (3) on hanger (7) and shackle (1).
6. Install two lubrication fittings (4) on two pins (5).
7. Ensure center bolt (26) of spring (2) is still seated in spring seat (13). If not seated, realign spring (2) and spring seat (13).
8. Apply sealant around top mating surface of metal base of rubber bumper (10) and saddle (9) and seat bumper (10) base in saddle (9).
9. Install saddle (9) over spring (2) so center bolt (26) is in recess of rubber bumper (10) base.
10. Install two U-bolts (8) over saddle (9) and spring (2).
11. Position plate (15) on u-bolts (8) under axle housing (12) and install four new lockwashers (16) and nuts (17). Plate (15) must have shock absorber hole on wheel side of spring (2) toward rear of front axle housing (12) and angled down. Tighten nuts (17) 190-230 lb-ft (258-312 N·m).
12. Install retainer (24) and rubber bushing (23) on shock absorber piston rod (25) and extend through hole in plate (15). Ensure projecting lip of bushing (23) is seated in plate (15).
13. Install rubber bushing (21), retainer (20), and nut (19) on shock absorber piston rod (25). Tighten nut (19) until bushings (21) and (23) start to bulge.
14. Install jamnut (18) and tighten against nut (19).
15. Raise vehicle and remove two jack stands (11) from frame (27) and place under front axle (12) to allow front wheel installation.

7-13. FRONT SPRING REPLACEMENT (Contd)

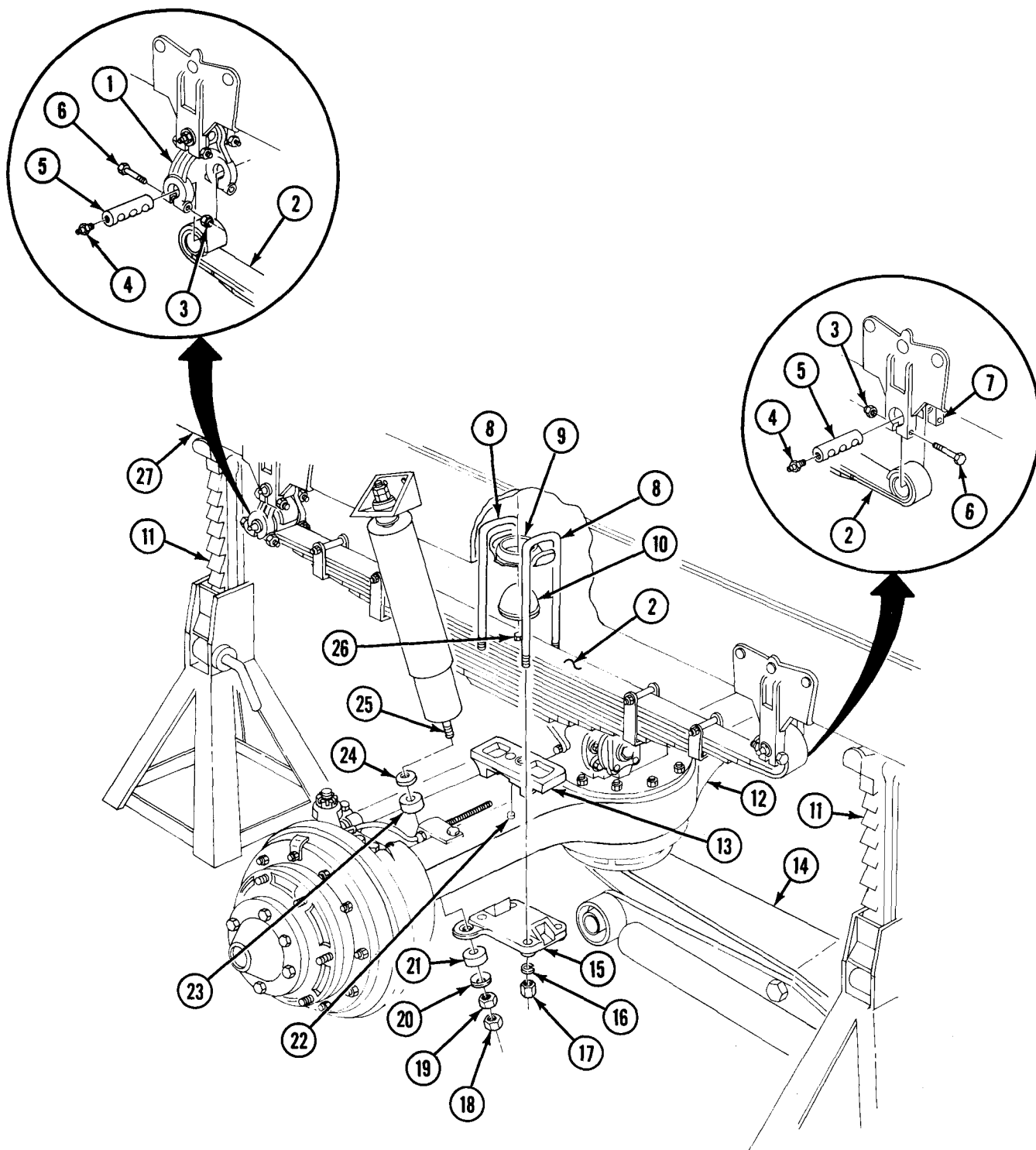

FOLLOW-ON TASKS: •Install front right wheel (para. 9-2).  
 •Lubricate shackle and hanger fittings (LO 9-2320-209-12-1).

**7-14. FRONT SPRING SHACKLE REPLACEMENT**

**This task covers:**

**a. Removal**

**b. Installation**

INITIAL SETUP:

APPLICABLE MODELS

All

MATERIALS/PARTS

Four locknuts

REFERENCES (TM)

LO 9-2320-209-12-1

TM 9-2320-361-10

TM 9-2320-361-20P

EQUIPMENT CONDITION

- Parking brake set (TM 9-2320-361-10).
- Front right wheel removed (para. 9-2).

**a. Removal**

**NOTE**

Left and right front spring shackles are replaced the same way. This procedure covers the right side.

1. Raise front of vehicle and remove two jack stands (16) from under front axle (15).
2. Support vehicle at frame (22) with two jack stands (16).
3. Place hydraulic jack (11) under front axle (15).
4. Remove jamnut (12), nut (13), retainer (14), and rubber bushing (10) from shock absorber piston rod (6).
5. Push shock absorber piston rod (6) up and out of plate (9).
6. Remove rubber bushing (8) and retainer (7) from shock absorber piston rod (6).
7. Remove two locknuts (17) and screws (20) from shackle (4). Discard locknuts (17).
8. Remove two lubrication fittings (19) from pins (18) and (21).
9. Remove pin (18) from spring (5).
10. Lower hydraulic jack until spring (5) is free of shackle (4).
11. Remove two locknuts (3) and screws (1) from hanger (2). Discard locknuts (3).
12. Remove pin (21) and shackle (4) from hanger (2).

**b. Installation**

1. Install shackle (4) in hanger (2) with pin (21). Aline grooves in pin (21) with screw (1) holes in shackle (4).
2. Install two screws (1) and new locknuts (3) on hanger (2).
3. Lift front axle (15) and spring (5), aline holes in spring (5) and shackle (4), and install pin (18). Aline grooves in pin (18) with retaining screw (20) holes in shackle (4).
4. Install two screws (20) and new locknuts (17) on shackle (4).
5. Install two lubrication fittings (19) in pins (18) and (21).
6. Install retainer (7) and rubber bushing (8) on shock absorber piston rod (6). Ensure lip of rubber bushing (8) is seated towards hole in plate (9).
7. Extend shock absorber piston rod (6) through hole in plate (9), and install rubber bushing (10), retainer (14), and nut (13) on shock absorber piston rod (6). Tighten nut (13) until bushings (8) and (10) start to bulge.
8. Install jamnut (12) on piston rod (6) and tighten against nut (13).

## 7-14. FRONT SPRING SHACKLE REPLACEMENT (Contd)

9. Raise vehicle and remove two jack stands (16) from frame (22) and place under front axle (15) to allow front wheel installation.

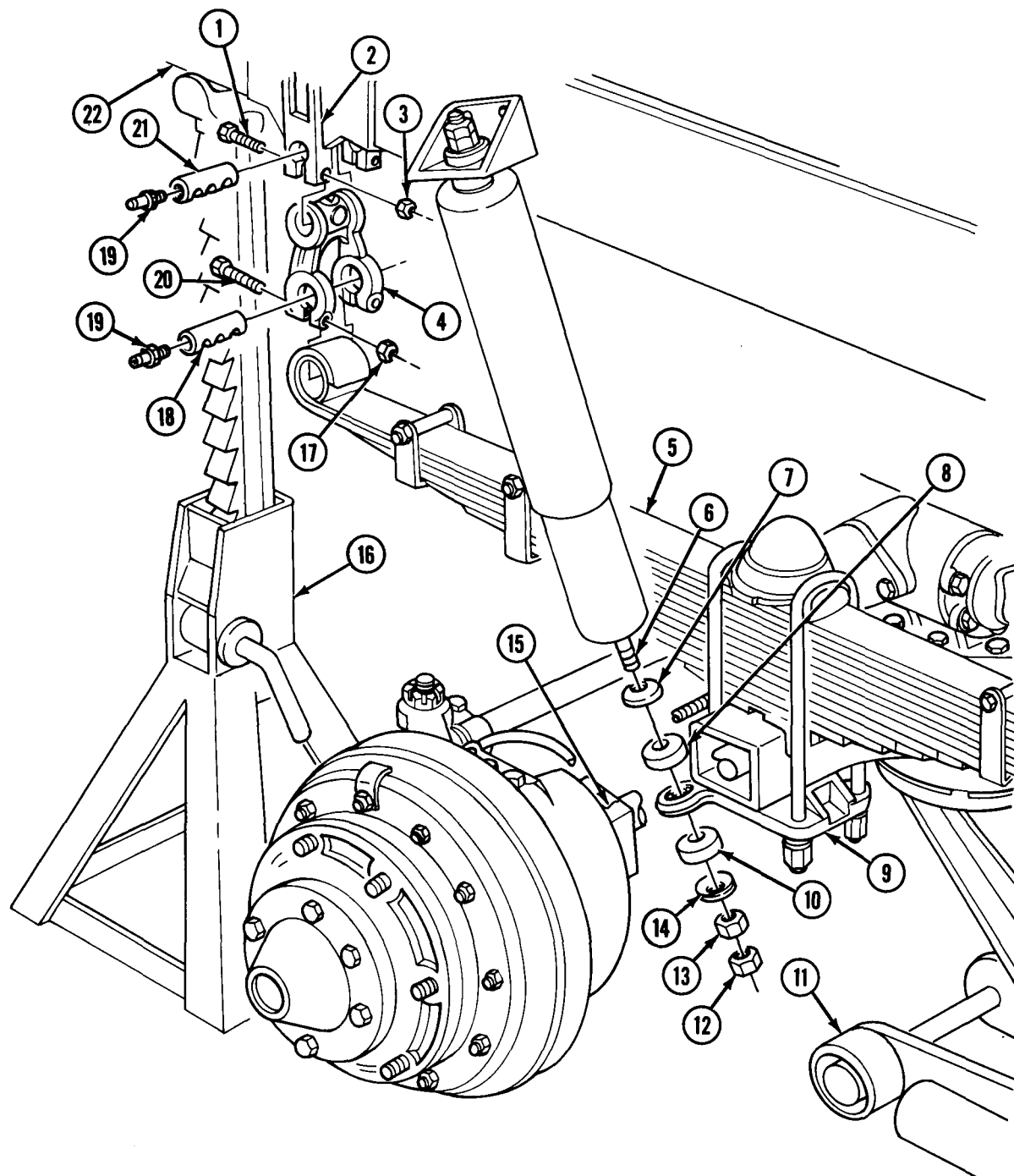

- FOLLOW-ON TASKS**• Install front right wheel (para. 9-2).  
 • Lubricate shackle fittings (LO 9-2320-209-12-1).



**7-15. FRONT SPRING BUMPER REPLACEMENT**

This task covers:

**a. Removal**

**b. Installation**

INITIAL SETUP:

APPLICABLE MODELS

All

MATERIALS/PARTS

Four lockwashers  
Adhesive sealant (Appendix C, Item 5)

REFERENCES (TM)

TM 9-2320-361-10  
TM 9-2320-361-20P

EQUIPMENT CONDITION

Parking brake set (TM 9-2320-361-10).

**a. Removal**

**NOTE**

Left and right spring bumpers and seats are replaced the same way. This procedure covers the right side.

1. Remove four nuts (7), lockwashers (6), two U-bolts (1), bumper (3), and saddle (2) from spring (4) and plate (5). Discard lockwashers (6).
2. Remove saddle (2) from bumper (3).

**b. Installation**

1. Apply sealant around top mating surface of metal base of bumper (3) and saddle (2).
2. Install bumper (3) in saddle (2) and set saddle (2) over center bolt (8) on spring (4).
3. Install two U-bolts (1) over saddle (2) and plate (5) with four new lockwashers (6) and nuts (7). Tighten nuts (7) 190-230 lb-ft (258-312 N·m).

7-15. FRONT SPRING BUMPER REPLACEMENT (Contd)

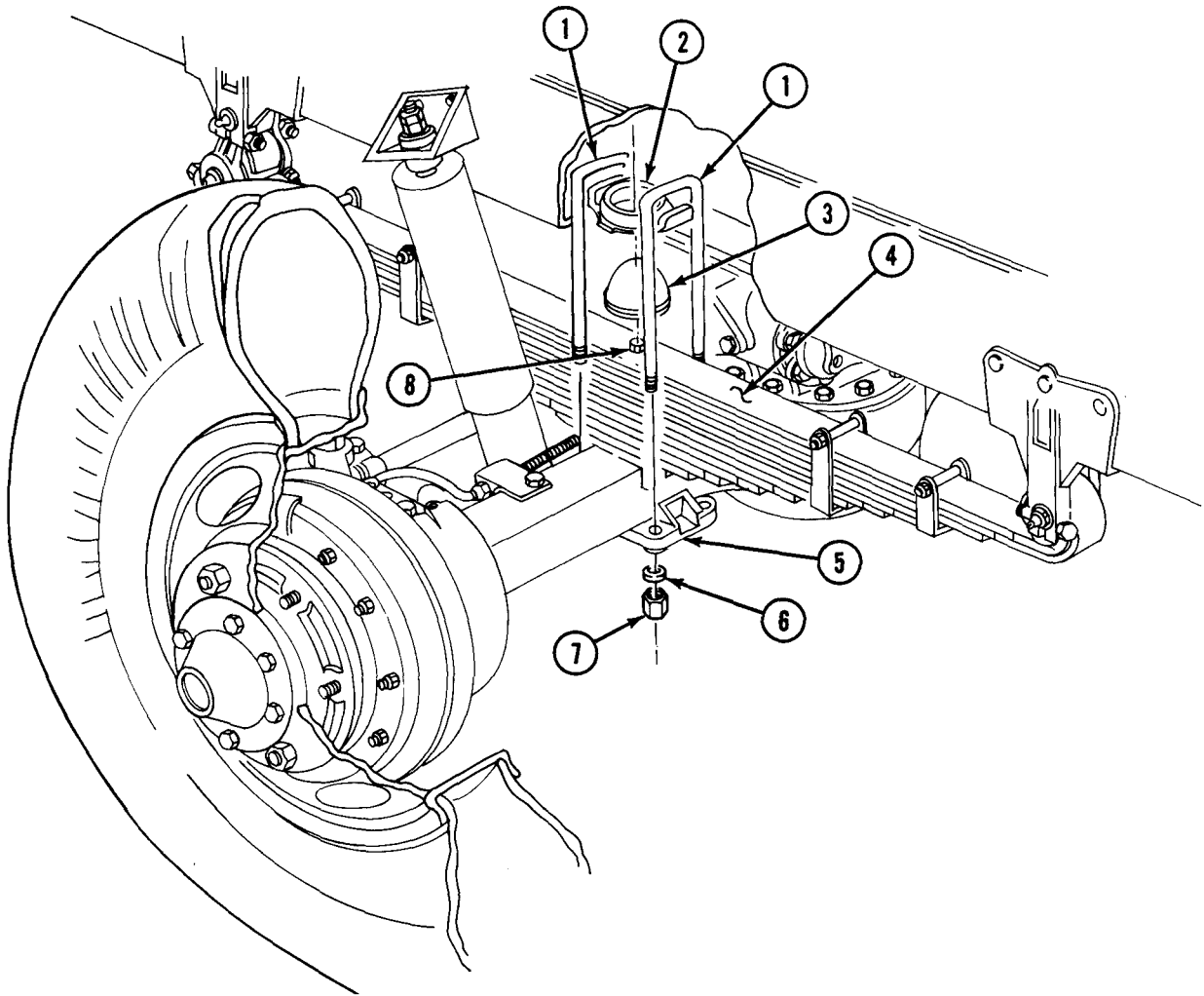

**7-16. FRONT SPRING MAINTENANCE**

This task covers:

- a. Disassembly
- b. Cleaning and Inspection

c. Assembly

INITIAL SETUP:

APPLICABLE MODELS

All

MATERIALS/PARTS

Center bolt  
 Nut  
 Four leaf clip screws  
 Four leaf clip nuts  
 Four leaf clip rivets  
 Graphite grease (Appendix C, Item 15)  
 Rags (Appendix C, Item 21)  
 Drycleaning solvent (Appendix C, Item 26)

REFERENCES (TM)

TM 9-2320-361-20P

EQUIPMENT CONDITION

Front spring removed (para 7-13).

GENERAL SAFETY INSTRUCTIONS

- Spring leaves and plates are under tension, release tension slowly.
- Keep fire extinguisher nearby when using drycleaning solvent.

**a. Disassembly**

**NOTE**

- Some springs have two leaves and eight plates, and others have two leaves and ten plates. Both types are maintained the same. This procedure covers the spring with eight plates.
- Only the two leaves of the spring can be replaced. Damaged plates require replacement of whole spring.

1. Position C-clamp (7) on spring (4) near center bolt (6). Ensure C-clamp (7) is vertically centered and square across spring (4).
2. Remove four nuts (11), screws (8), and spacers (10) from two long leaf clips (5) and short leaf clips (3). Discard nuts (11) and screws (8).

**WARNING**

Leaves and plates of assembled spring are under tension. Restrain all leaves and plates while removing center bolt. Release tension slowly. Failure to do so may result in injury to personnel.

3. Remove nut (12) and center bolt (6) from spring (4). Discard center bolt (6) and nut (12).
4. Slowly loosen C-clamp (7) until tension on plates (16) and leaves (13) is released. Remove leaf (14) from leaf (15).
5. Center punch and drill out rivets (17) from two long leaf clips (5) and short leaf clips (3). Discard rivets (17).
6. Remove bushings (2) and (9) from eyes (1) of leaf (14).

7-16. FRONT SPRING MAINTENANCE (Contd)

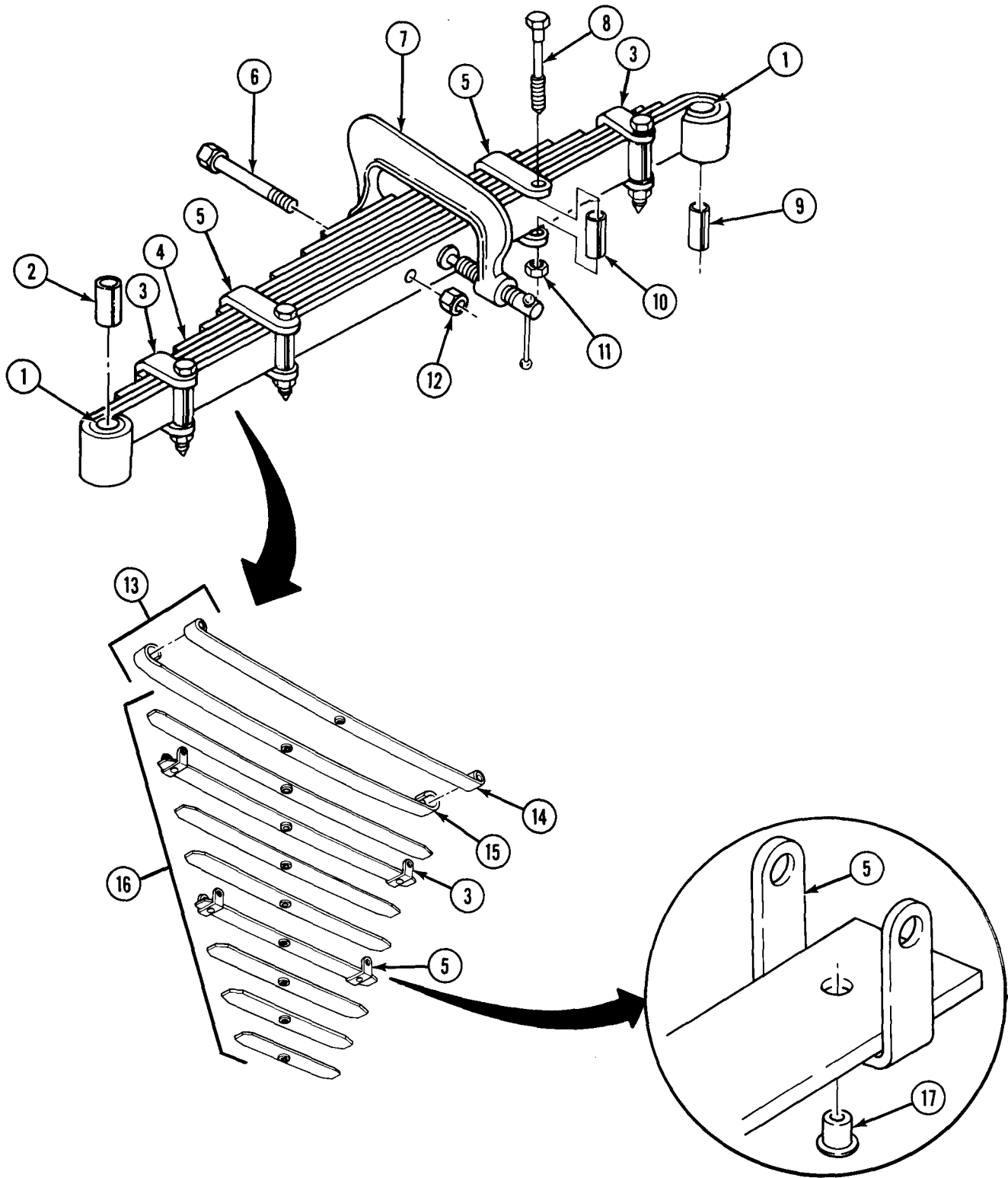

## 7-16. FRONT SPRING MAINTENANCE (Contd)

### b. Cleaning and Inspection

#### **WARNING**

Drycleaning solvent is flammable and will not be used near open flame. Use only in well-ventilated places. Failure to do so may result in injury to personnel.

1. Clean all parts with wire brush to remove dirt, rust, and corrosion.
2. Wash all parts in drycleaning solvent. Dry with clean rag.
3. Inspect two bushings (7) and (11) for looseness and freeplay. Replace bushings (7) or (11) if damaged.

#### **NOTE**

Only the two leaves of the spring can be replaced. Damaged plates require replacement of whole spring.

4. Inspect plates (15) through (22) for breaks or cracks. Replace entire spring (12) if any plates are broken or cracked.
5. Inspect all other parts for cracks and breaks. Replace all other cracked or broken parts.

### c. Assembly

1. Position two long leaf clips (3) on plate (19) and install with two new rivets (24).
2. Position two short leaf clips (5) on plate (16) and install with two new rivets (23).
3. Apply graphite grease between plates and leaves while assembling.
4. Assemble leaf (13) in leaf (14) before placing over new center bolt (1).
5. Assemble plates (22) through (15) and leaves (13) and (14) on new center bolt (1) on a flat surface.

#### **WARNING**

When assembling plates and leaves with C-clamp, the plates and leaves will be under tension. Use care not to disturb the assembly until center bolt and nut are tightened. Failure to do so may result in injury to personnel.

6. Install C-clamp (2) over leaves (13) and (14) and plates (15) through (22). Ensure there is clearance for center bolt (1) and nut (10), and C-clamp (2) is squared and vertically centered across spring plate assembly (12).
7. Tighten C-clamp (2) and install new nut (10) on new center bolt (1). Remove C-clamp (2) and peen end of center bolt (1) to nut (10).
8. Install four spacers (8) in plate clips (5) and (3) with four new leaf screws (4) and new nuts (9). Tighten nut (9) if leaf clip is loose. Ensure leaves and plates are parallel and not binding at sides of leaf clips. Peen clip screws (4) over nuts (9).
9. Coat outside of bushings (11) and (7) with graphite grease.
10. Install bushings (7) and (11) in leaf eyes (6).

7-16. FRONT SPRING MAINTENANCE (Contd)

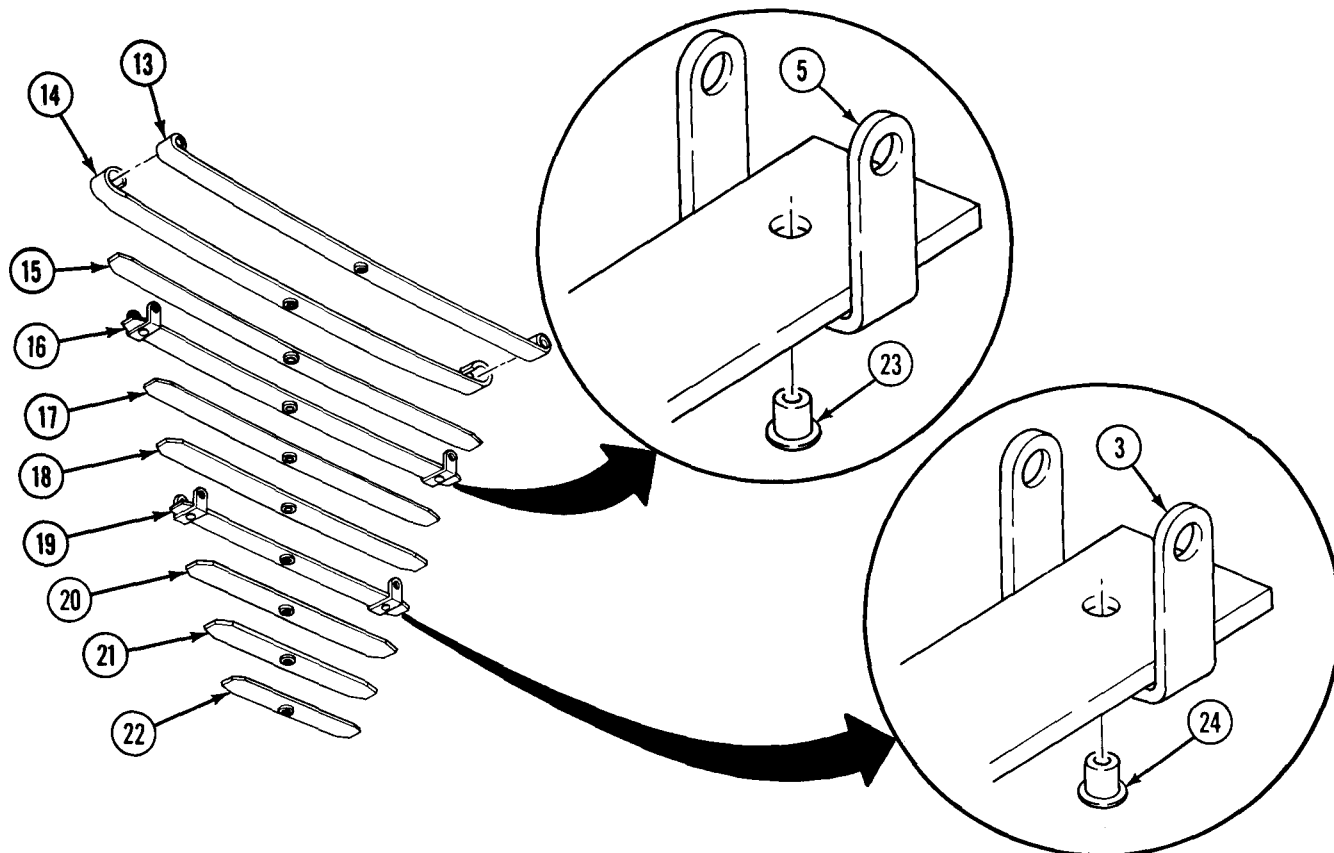
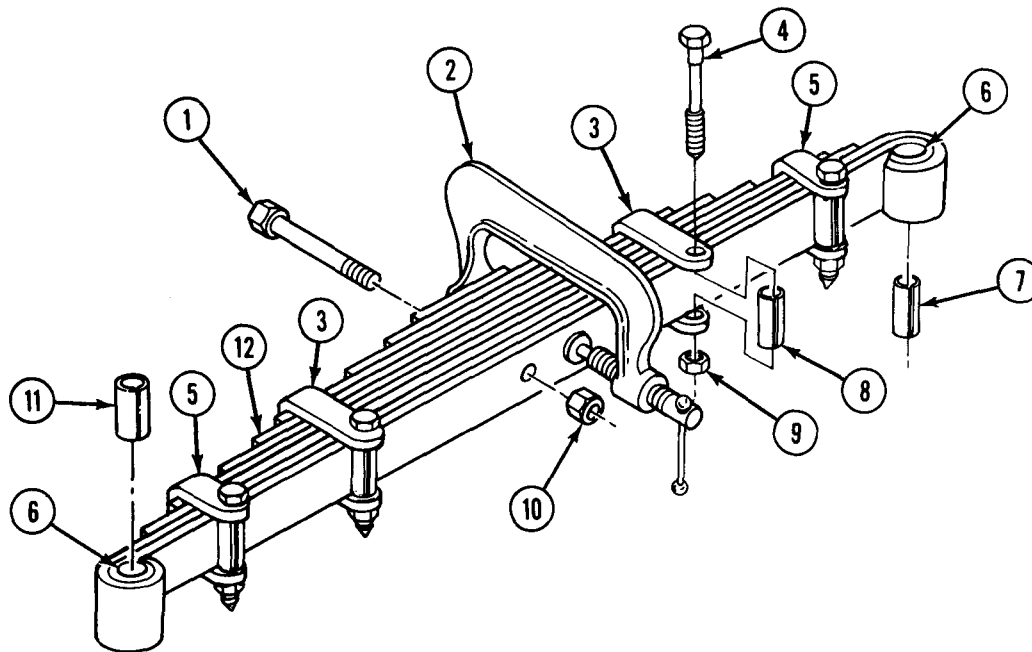

FOLLOW-ON TASK: Install front spring (para. 7-13).

**7-17. REAR SPRING REPLACEMENT**

This task covers:

**a. Removal**

**b. Installation**

INITIAL SETUP:

APPLICABLE MODELS

All

REFERENCES (TM)

TM 9-2320-361-20P

MATERIALS/PARTS

Six lockwashers

EQUIPMENT CONDITION

Rear spring wear pads removed (para. 7-21).

PERSONNEL REQUIRED

Two

**a. Removal**

**NOTE**

Left and right rear springs are replaced the same way. This procedure covers the left side.

1. Remove four nuts (7), lockwashers (8), two U-bolts (3), and saddle (2) from spring (1). Discard lockwashers (8).
2. Remove two screws (5) and lockwashers (4) from spring seat (9). Discard lockwashers (4).

**NOTE**

Assistant will help with step 3.

3. Remove spring (1) from spring seat (9) and rear axles (10) and (6).

**b. Installation**

**NOTE**

Assistant will help with step 1.

1. Position and aline spring (1) on spring seat (9) and rear axles (6) and (10).
2. Install two new lockwashers (4) and bolts (5) on spring seat (9). Tighten screws (5) 280-365 lb-ft (380-495 NŹm).
3. Position saddle (2) over spring (1) and center bolt (11) and install two U-bolts (3) with four new lockwashers (8) and nuts (7). Tighten nuts (7) 190-220 lb-ft (258-298 NŹm).

7-17. REAR SPRING REPLACEMENT (Contd]

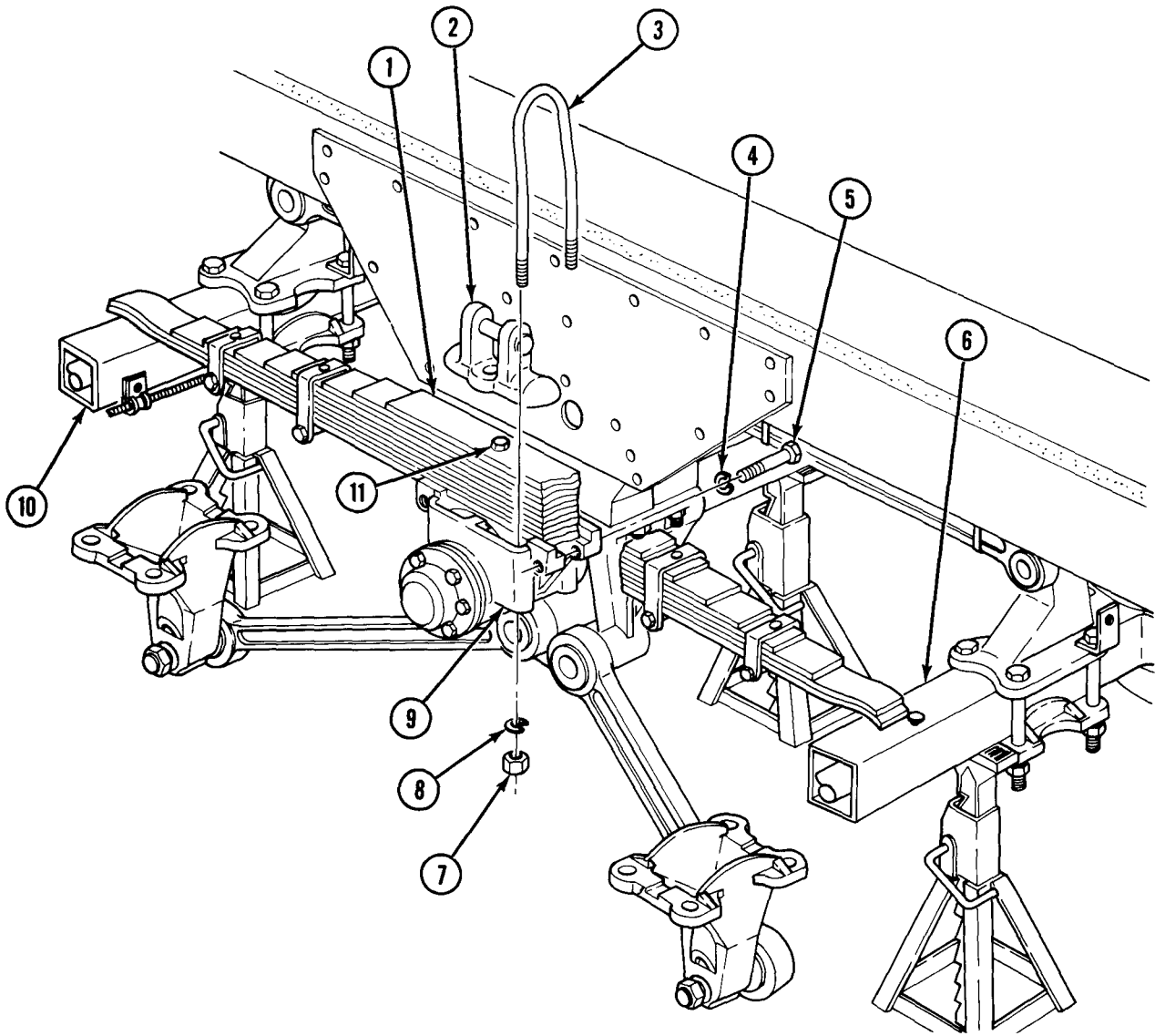

FOLLOW-ON TASK: Install rear spring wear pads (para. 7-21).



**7-18. REAR SPRING MAINTENANCE**

This task covers:

- |   |                    |
|---|--------------------|
| <p>a. Disassembly<br/>b. <b>Cleaning and Inspection</b></p> | <p>c. Assembly</p> |
|---|--------------------|

**INITIAL SETUP:**

APPLICABLE MODELS

All

MATERIALS/PARTS

- Center bolt
- Nut
- Four leaf clip screws
- Four leaf clip nuts
- Four leaf clip rivets
- Graphite grease (Appendix C, Item 15)
- Rags (Appendix C, Item 21)
- Drycleaning solvent (Appendix C, Item 26)

REFERENCES (TM)

TM 9-2320-361-20P

EQUIPMENT CONDITION

Rear spring removed (para. 7-17).

GENERAL SAFETY INSTRUCTIONS

- Spring leaves and plates are under tension, release tension slowly.
- Keep fire extinguisher nearby when using drycleaning solvent.

**NOTE**

- Some springs have two leaves and eight plates, and others have two leaves and ten plates. Both types are maintained the same. This procedure covers the spring with eight plates.
  - Only the two leaves of the spring can be replaced. Damaged plates require replacement of whole spring.
1. Position C-clamp (4) on spring (2) near center bolt (7). Ensure C-clamp (4) is vertically centered and square across spring (2).
  2. Remove four nuts (1), screws (9), and spacers (8) from two long leaf clips (6) and short leaf clips (5). Discard nuts (1) and screws (9).

**WARNING**

Spring leaves are under tension. Restrain all leaves and plates while removing center bolt. Release tension slowly. Failure to do so may result in injury to personnel.

3. Remove nut (3) and center bolt (7) from spring (2). Discard center bolt (7) and nut (3).
4. Slowly loosen C-clamp (4) until tension on plates (10) and (11), and leaves (12) through (19) is released. Remove C-clamp (4) from spring (2).
5. Center punch and drill out rivets (20) from two long leaf clips (6) and short leaf clips (5). Discard rivets (20).

**b. Cleaning and Inspection**

**WARNING**

Drycleaning solvent is flammable and will not be used near open flame. Use only in well-ventilated places. Failure to do so may result in injury to personnel.

1. Clean all parts with drycleaning solvent. Use wire brush to remove rust and corrosion. Dry with clean rag.
2. Inspect plates (12) through (19) and leaves (10) and (11) for breaks and cracks. Replace leaves (10) and (11) if broken or cracked. Broken or cracked plates require replacement of entire spring.
3. Inspect long leaf clips (6), short leaf clips (5), and spacers (8) for cracks or breaks. Replace clips (6) and (5), and spacers (8) if cracked or broken.

**7-18. REAR SPRING MAINTENANCE (Contd]**

**c. Assembly**

1. Install two short leaf clips (5) on plate (13) with two new rivets (20). Seat rivet (20) ends in plate (13).
2. Install two long leaf clips (6) on plate (16) with two new rivets (20). Seat rivet (20) ends in plate (16).

**WARNING**

When assembling plates and leaves with C-clamp, the plates and leaves will be under tension. Use care not to disturb the assembly until center bolt and nut are tightened. Failure to do so may result in injury to personnel.

3. Place new center bolt (7) through lower spring leaf (10) and coat upper side of leaf (10) with graphite grease.
4. Install C-clamp (4) over leaves (10) and (11) and plates (12) through (19). Ensure there is clearance for head of center bolt (7) and nut (3). C-clamp (4) must be squared and centered vertically across leaf and plate assembly.
5. Tighten C-clamp (4), and install new nut (3) on new center bolt (7). Remove C-clamp (4) and peen over center bolt (7) on nut (3).
6. Install four spacers (8) in leaf clips (5) and (6) with four new screws (9) and new nuts (1). Tighten nut (3) if led-clip is loose. Ensure leaves and plates are parallel and not binding at sides of leaf clips. Peen over clip screws (9) on nuts (1).

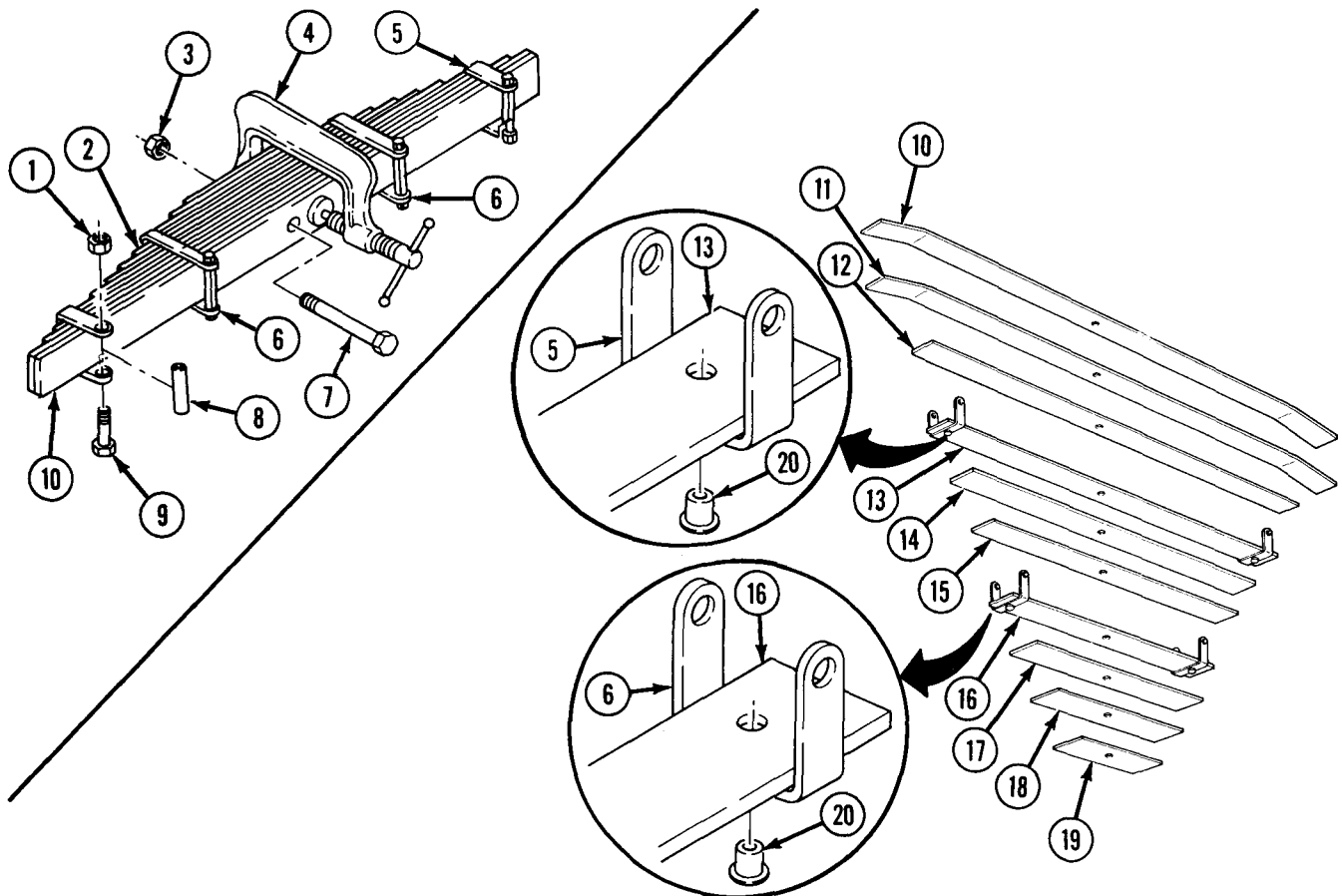

FOLLOW-ON TASK: Install rear spring (para. 7-17).

## 7-19. REAR SPRING SEAT REPLACEMENT

This task covers:

### a. Removal

### b. Installation

#### INITIAL SETUP:

##### APPLICABLE MODELS

All

##### MATERIALS/PARTS

Twelve lockwashers

Gasket

Washer

Seal

Felt seal

Woodruff key

Two bushing assemblies

GAA grease (Appendix C, Item 13)

Rags (Appendix C, Item 21)

##### REFERENCES (TM)

LO 9-2320-209-12-1

TM 9-2320-361-10

TM 9-2320-361-20P

##### EQUIPMENT CONDITION

- Parking brake set (TM 9-2320-261-10).
- Forward-rear and rear-rear axle wheels removed (para. 9-2).

##### GENERAL SAFETY INSTRUCTIONS

Ensure vehicle is firmly supported.

### a. Removal

#### WARNING

Ensure vehicle is firmly supported while spring seat is removed. Injury to personnel can result.

#### **NOTE**

Right and left spring seats are replaced the same way. This procedure covers the left side.

1. Support vehicle with two jack stands (5) at tandem axle bracket (4).
2. Raise axles (7) so that spring (1) is not resting against brackets (6).
3. Remove two screws (9) and lockwashers (10) from spring seat (23). Discard lockwashers (10).
4. Remove four nuts (12), lockwashers (11), two U-bolts (2), and saddle (3) from spring (1). Discard lockwashers (11).
5. Raise and support rear-rear axle (7) until spring (1) is lifted off spring seat (23). Readjust jack stands (8) under axle (7).
6. Remove six screws (19), lockwashers (20), pack cover (21), and gasket (22) from spring seat (23). Discard lockwashers (20) and gasket (22).
7. Straighten washer (17) tabs.
8. Remove nut (18), washer (17), nut (16), outer bushing (15), and spring seat (23) from tandem axle bracket (4) end. Discard washer (17).
9. Remove two bushing cups (14) and (28) from spring seat (23). Discard bushing cups (14) and (28).
10. Remove plug (13) from spring seat (23).
11. Remove inner bushing (29), seal (27), retainer (26), felt seal (25), washer (24), and woodruff key (30) from tandem axle bracket (4) end. Do not bend washer (24) or retainer (26). Discard seal (27), felt seal (25), and woodruff key (30).

### b. Installation

1. Position new felt seal (25) on retainer (26).
2. Install two new bushing cups (14) and (28) in spring seat (23).
3. Apply a film of GAA grease to tandem axle bracket (4) end, new seal (27), spring seat (23), and inner bushing (29).

## 7-19. REAR SPRING SEAT REPLACEMENT (Contd)

4. Install washer (24), new felt seal (25), retainer (26), new seal (27), inner bushing (29), and new woodruff key (30) over tandem axle bracket (4) end.
5. Place spring seat (23) over inner bushing (29).
6. Apply a film of GAA grease to outer bushing (15) and end of tandem axle bracket (4) and install in spring seat (23) with nut (16). Tighten nut (16) 60 lb-ft (81 NŹm). Back off nut (16) about 1/4 turn.
7. Install new washer (17) and nut (18) on tandem axle bracket (4) end. Tighten nut (18) 100-150 lb-ft (136-203 NŹm). Bend washer (17) tabs against nut (18).
8. Apply light film of GAA grease to both sides of gasket (22).
9. Install gasket (22) and pack cover (21) on spring seat (23) with six new lockwashers (20) and screws (19). Tighten screws (19) 16-20 lb-ft (22-27 NŹm). Wipe away excess grease with rag.
10. Raise rear-rear axle (7) with hydraulic jack, adjust jackstands (8), and lower axle (7) onto spring seat (23). Position center bolt (31) in recess of spring seat (23).
11. Install plug (13) on spring seat (23).
12. Position saddle (3) over spring center bolt (31) and install with two U-bolts (2), four new lockwashers (11), and nuts (12). Tighten nuts (12) 190-220 lb-ft (258-298 NŹm).
13. Install two new lockwashers (10) and screws (9) in spring seat (23). Tighten screws (9) 280-365 lb-ft (380-495 NŹm).
14. Raise vehicle and remove jack stand (5). Lower and remove hydraulic jack.

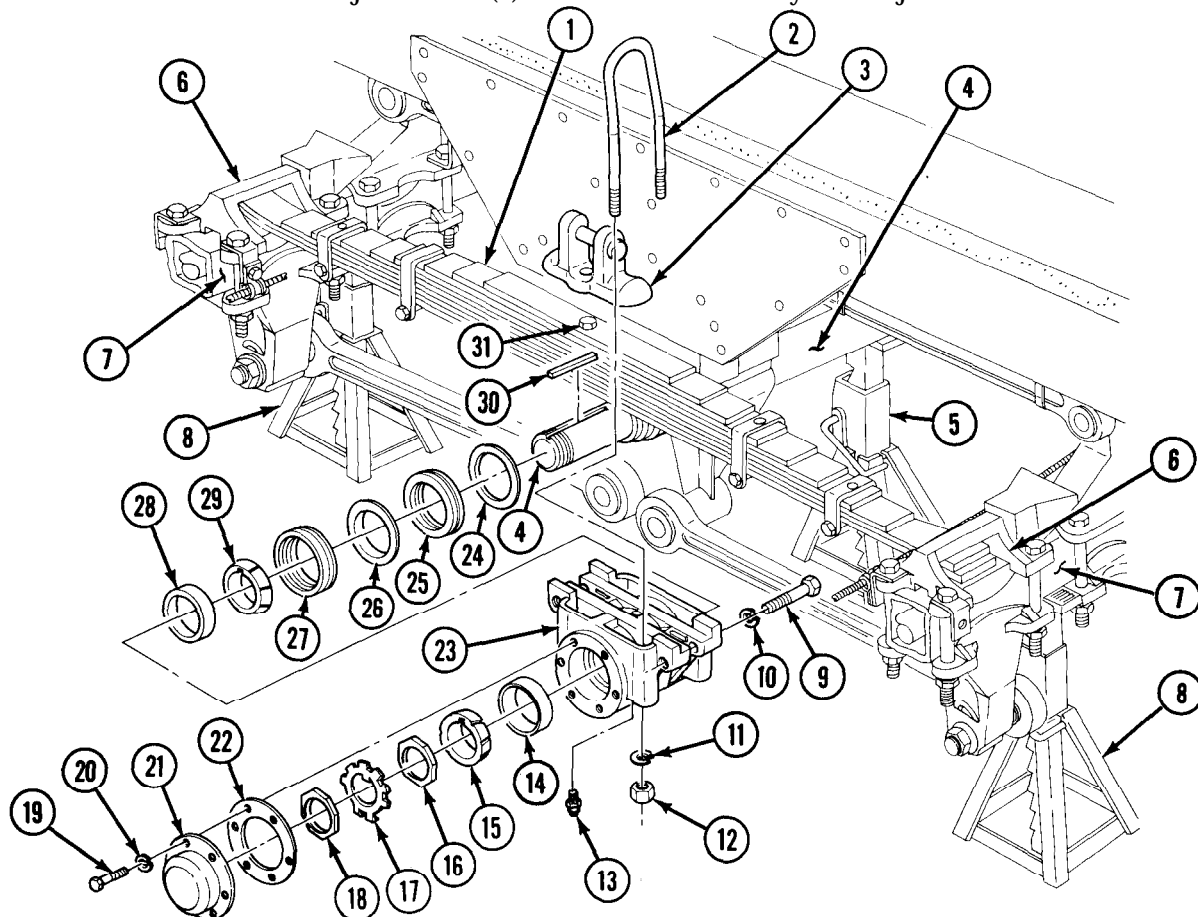

**FOLLOW-ON TASKS:**

- Install rear-rear axle and forward-rear axle wheels (para. 9-2).
- Lubricate spring seat (LO 9-2320-209-12-1).

<b>7-20. SHOCK ABSORBER REPLACEMENT</b>
---

This task covers:

**a. Removal**

**b. Installation**

**INITIAL SETUP:**

APPLICABLE MODELS

All

EQUIPMENT CONDITION

Parking brake set (TM 9-2320-361-10).

REFERENCES (TM)

TM 9-2320-361-10

TM 9-2320-361-20P

<b>a. Removal</b>
-------------------

1. Remove jamnut (17), nut (16), retainer (15), and rubber bushing (14) from shock absorber piston rod (10).
2. Push shock absorber piston rod (10) up through hole in plate (13) and remove upper rubber bushing (12) and retainer (11).
3. Remove jamnut (5), nut (4), upper retainer (3), and rubber bushing (2) from upper rod (8).
4. Remove shock absorber (9), lower retainer (7), and rubber bushing (6) from of frame bracket (1).

<b>b. Installation</b>
------------------------

1. Position retainer (7) and rubber bushing (6) on upper rod (8) of shock absorber (9). Ensure lip of bushing (6) is facing up.
2. Position upper rod (8) through hole in frame bracket (1) and install rubber bushing (2), retainer (3), and nut (4) on rod (8). Ensure lip of bushing (2) is in hole in frame bracket (1).
3. Tighten nut (4) until two rubber bushings (2) and (6) start to bulge.
4. Install jamnut (5) against nut (4).
5. Install retainer (11) and rubber bushing (12) on piston rod (10). Ensure lip of rubber bushing (12) is facing down.
6. Pull piston rod (10) down through hole in plate (13) and install rubber bushing (14), retainer (15), and nut (16). Ensure lip of bushing (14) is in hole of plate (13).
7. Tighten nut (16) until two rubber bushings (14) and (12) start to bulge.
8. Install jamnut (17) against nut (16).

7-20. SHOCK ABSORBER REPLACEMENT (Contd)

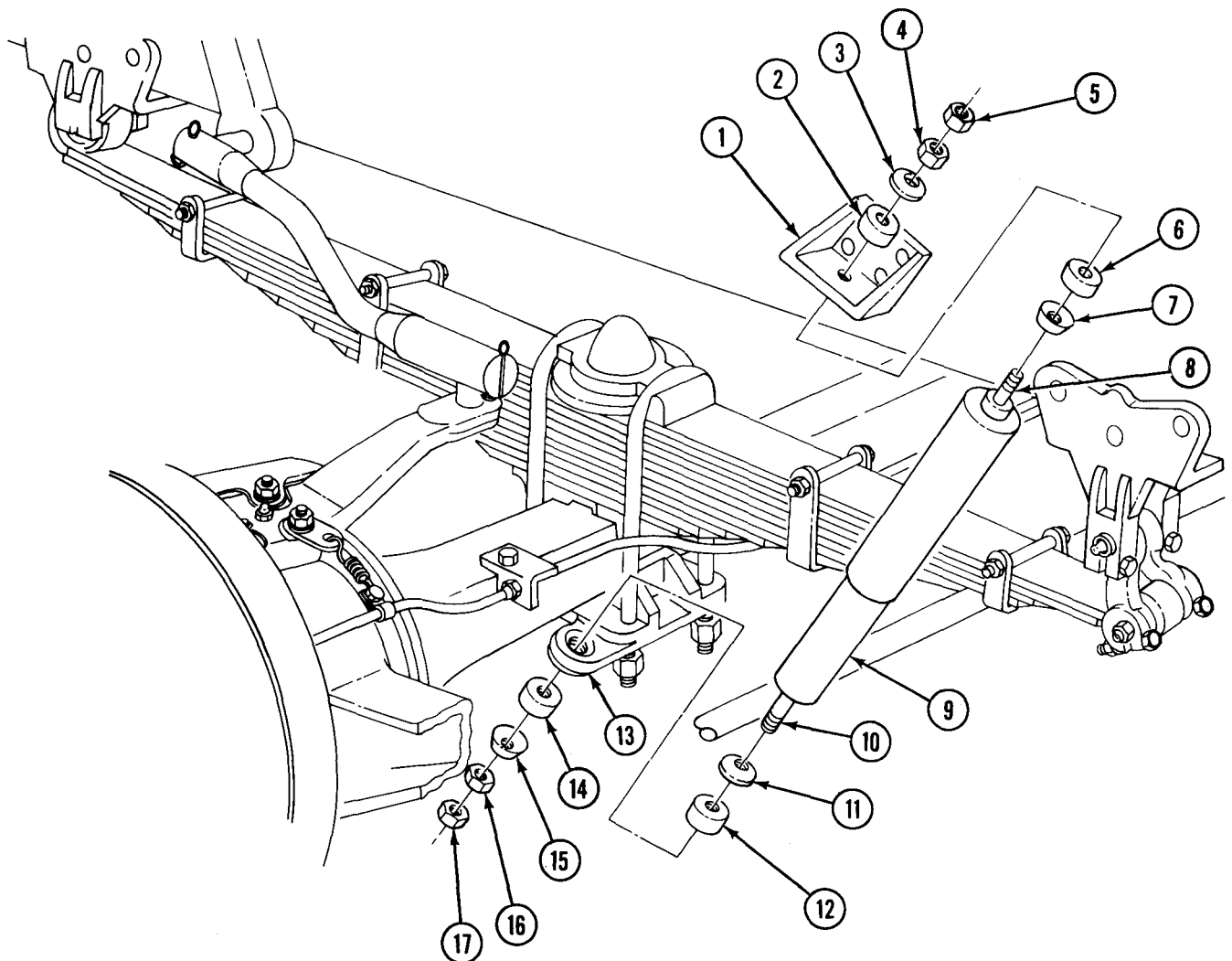

**7-21. REAR SPRING WEAR PAD REPLACEMENT**

**This task covers:**

**a. Removal**

**b. Installation**

INITIAL SETUP:

APPLICABLE MODELS

All

MATERIALS/PARTS

Wear pad  
Four lockwashers  
Locknut

REFERENCES (TM)

TM 9-2320-361-10  
TM 9-2320-361-20P

EQUIPMENT CONDITION

- Parking brake set (TM 9-2320-361-10).
- Rear left wheels removed (para. 9-2).

**a. Removal**

1. Raise spring seat (14) until spring (11) is lifted up in axle bracket (5) and support spring seat (14) with jack stand (13).
2. Remove locknut (12), screw (1), and clamp (2) from bracket (4). Discard locknut (12).
3. Remove four nuts (9), lockwashers (10), screws (3), bracket (4), and axle bracket (5) from axle housing (7) and mounting bracket (8). Discard lockwashers (10).
4. Remove wear pad (6) from axle bracket (5). Discard wear pad (6).

**b. Installation**

1. Install new wear pad (6) on axle bracket (5).
2. Position axle bracket (5) over spring (11) and install on axle housing (7) and mounting bracket (8) with two brackets (4), four screws (3), new lockwashers (10), and nuts (9). Tighten nuts (9) 200-275 lb-ft (271-373 NŹm).
3. Install clamp (2) on bracket (4) with screw (1) and new locknut (12).
4. Raise spring seat (14) and remove jack stand (13) from spring seat (14).

7-21. REAR SPRING WEAR PAD REPLACEMENT (Contd)

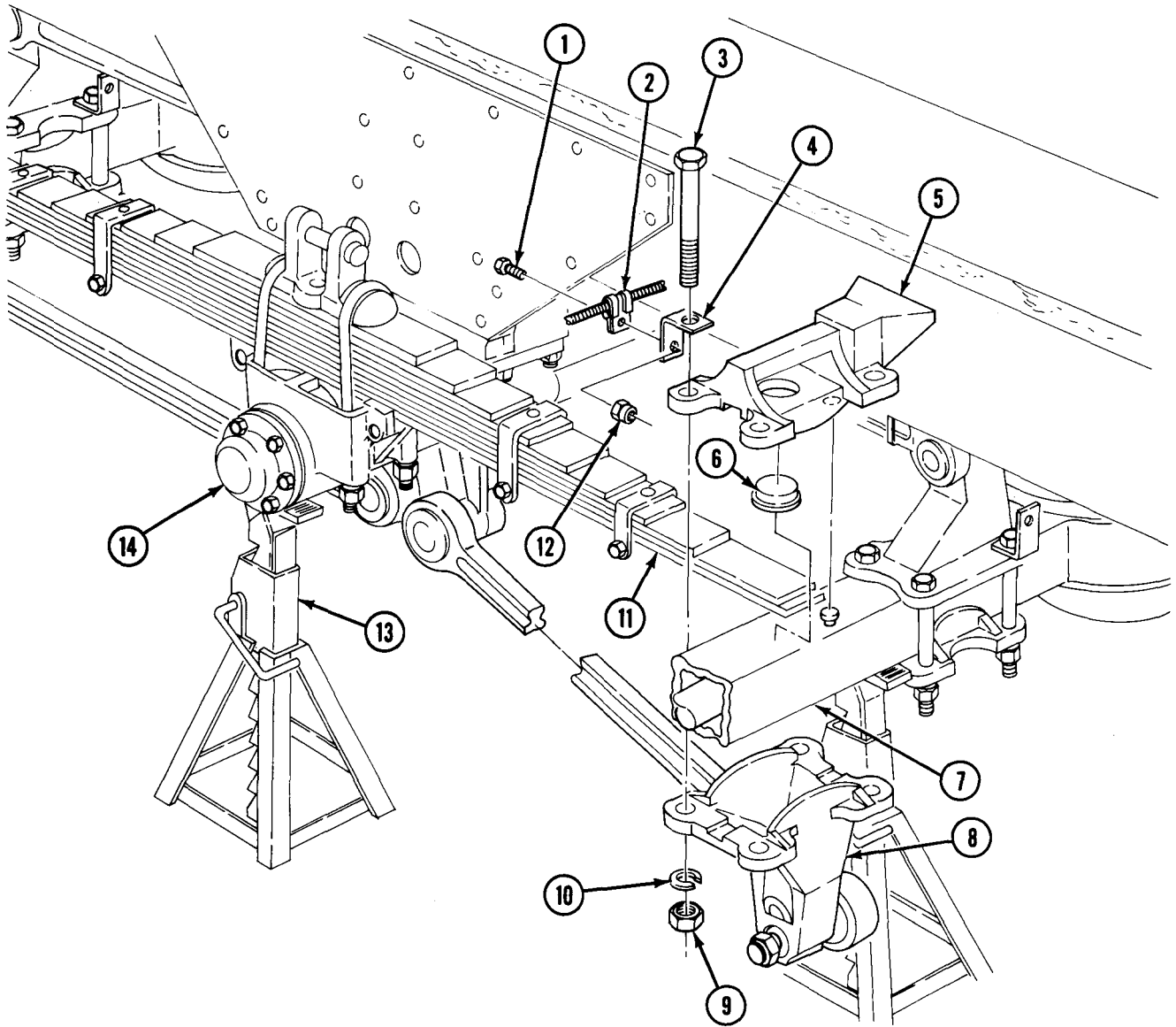

FOLLOW-ON TASK: Install left rear wheels (para. 9-2).



**7-22. TORQUE RODS REPLACEMENT**

This task covers:

**a. Removal**

**b. Installation**

INITIAL SETUP:

APPLICABLE MODELS

All

REFERENCES (TM)

TM 9-2320-361-10  
TM 9-2320-361-20P

MATERIALS/PARTS

Eight lockwashers  
Two tiedown straps (Appendix C, Item 20)

EQUIPMENT CONDITION

Rear wheels removed (as required) (para. 9-2).

PERSONNEL REQUIRED

Two

**NOTE**

- The left and right side torque rods are replaced the same. This procedure covers the left-rear side.
- Upper torque rods are on the left side.

**a. Removal**

1. Loosen nut (2) until even with end of torque rod (6) stud.
2. Using brass drift and sledge, strike stud and nut (2) to loosen stud from bracket (7).
3. Remove nut (2) and lockwasher (1) from torque rod (6) stud. Discard lockwasher (1).

**NOTE**

It maybe necessary to reposition jack stands to gain access to nut and lockwasher.

4. Remove nut (5) and lockwasher (4) from torque rod (6) stud on axle bracket (3). Discard lockwasher (4).

**NOTE**

It maybe necessary to tap bracket with hammer to loosen torque rod stud.

5. Remove torque rod (6) from vehicle.
6. Place jack under tandem axle bracket (10) near spring seat (18) and raise vehicle until spring (23) is lifted off front and rear spring seat brackets (14).
7. Remove four nuts (16) and lockwashers (15) from two U-bolts (8). Discard lockwashers (15).
8. Remove two U-bolts (8) and spring saddle (24) from spring seat (18).
9. Cut two tiedown straps (19) and remove brake line (17) from upper torque rod (20).
10. Loosen nut (21) until even with end of upper torque rod (20) stud.
11. Using brass drift and sledge, strike stud and nut (21) to loosen stud from bracket (9).
12. Remove nut (21) and lockwasher (22) from upper torque rod (20) stud. Discard lockwasher (22).
13. Remove nut (13) and lockwasher (12) from upper torque rod (20) stud on axle bracket (11). Discard lockwasher (12).

**NOTE**

It maybe necessary to tap bracket with hammer to loosen torque rod stud.

14. Remove upper torque rod (20) from vehicle.

7-22. TORQUE RODS REPLACEMENT (Contd)

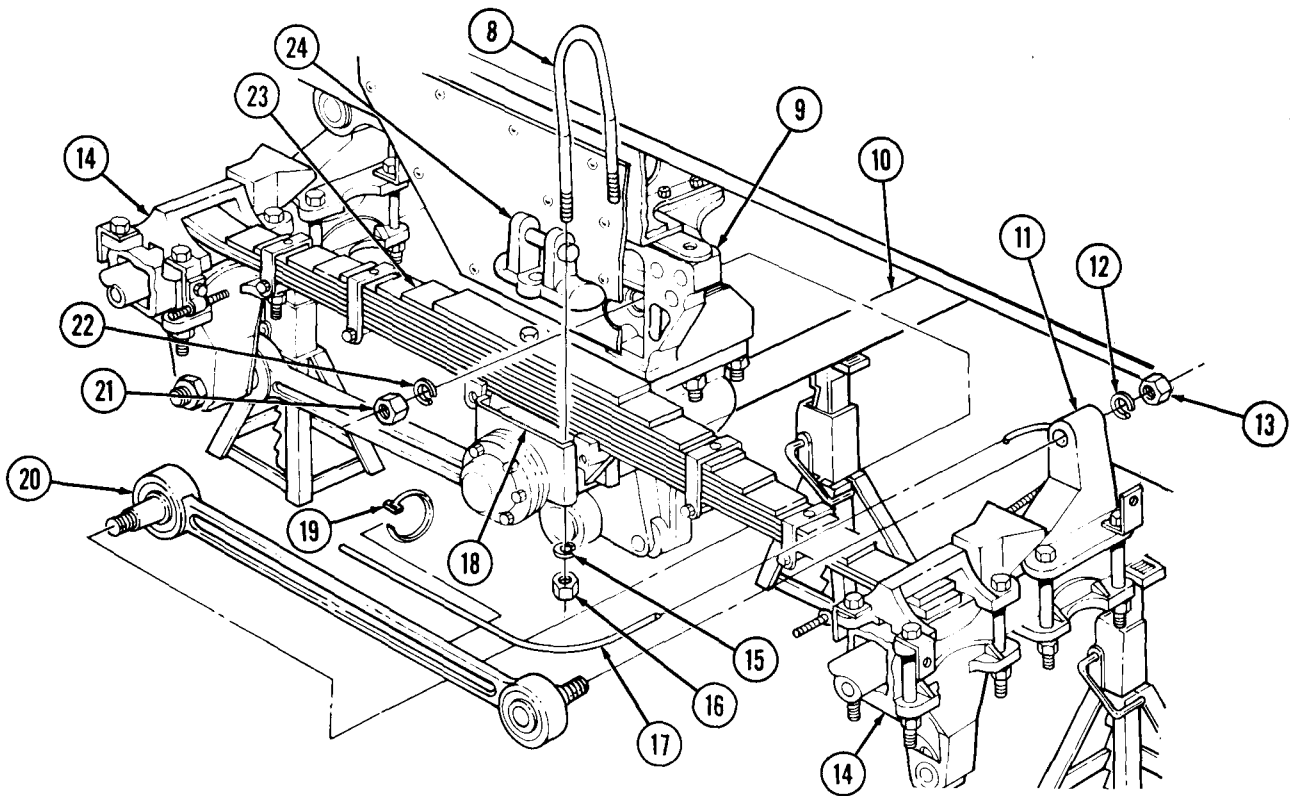
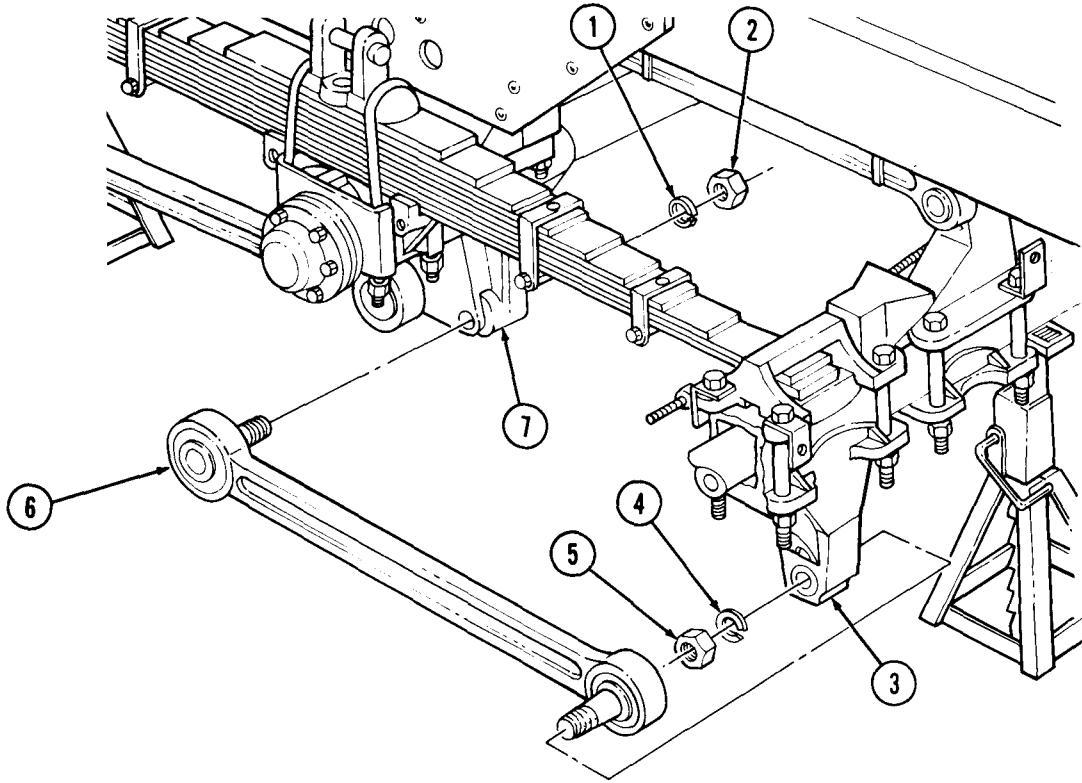

## 7-22. TORQUE RODS REPLACEMENT (Contd)

### b. Installation

1. Adjust jack under tandem axle bracket (4) until center of hole in axle bracket (6) is  $7.00 \pm 0.125$  in. ( $17.78 \pm 0.317$  cm) from lower edge of frame (5).
2. Install one end of upper torque rod (12) on bracket (3) with new lockwasher (16) and nut (15). Finger tighten nut (15).
3. Install other end of upper torque rod (12) on axle bracket (6) with new lockwasher (7) and nut (8). Tighten nuts (8) and (15) 175-200 lb-ft (237-271 N $\check{m}$ ).
4. Install brake line (11) on upper torque rod (12) with two new tiedown straps (14).
5. Install spring saddle (1) on spring seat (13) with two U-bolts (2), four new lockwashers (9), and nuts (10). Tighten nuts (10) 190-220 lb-ft (258-298 N $\check{m}$ ).
6. Install one end of torque rod (22) on bracket (23) with new lockwasher (17) and nut (18). Finger tighten nut (18).
7. Install other end of torque rod (22) on axle bracket (19) with new lockwasher (20) and nut (21). Tighten nuts (18) and (21) 175-200 lb-ft (237-271 N $\check{m}$ ).

7-22. TORQUE RODS REPLACEMENT (Contd)

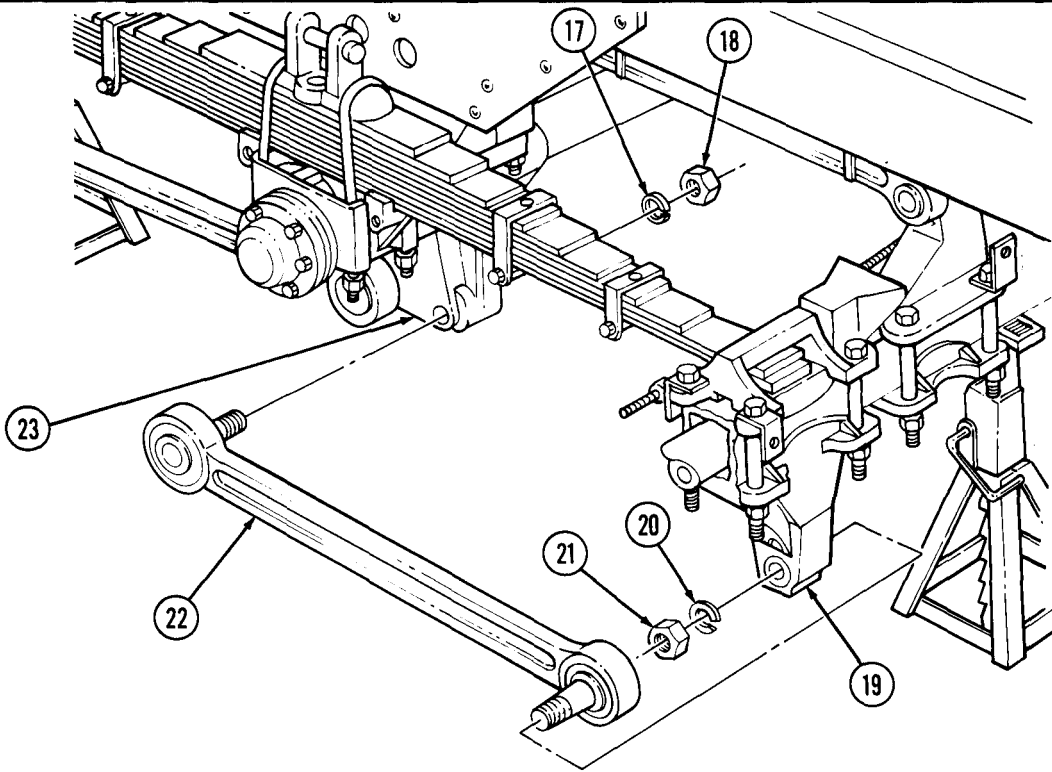
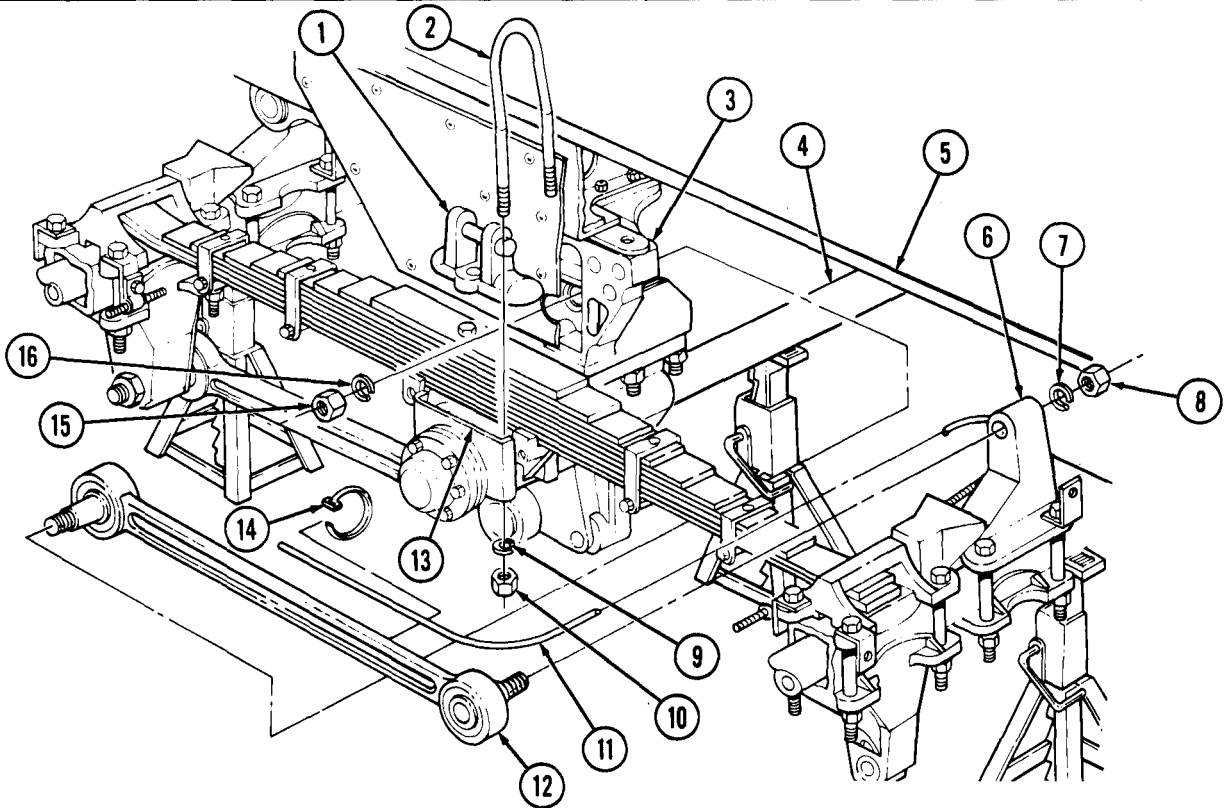

FOLLOW-ON TASK: Install rear wheels (as required) (para. 9-2).



## CHAPTER 8 PARKING BRAKE, COMPRESSED AIR, AND SERVICE BRAKE SYSTEM MAINTENANCE

Section I. Parking Brake Maintenance (page 8-1)  
Section II. Service Brake and Hydraulic Systems Maintenance (page 8-18)  
Section III. Compressed Air System Maintenance (page 8-45)

### Section I. PARKING BRAKE MAINTENANCE

#### 8-1. PARKING BRAKE MAINTENANCE INDEX

PARA. NO.	TITLE	PAGE NO.
8-2.	Parking Brakedrum Replacement	8-1
8-3.	Parking Brakeshoe Maintenance	8-4
8-4.	Parking Brake Cable Replacement	8-12
8-5.	Parking Brake Lever Replacement	8-16

#### 8-2. PARKING BRAKEDRUM REPLACEMENT

This task covers:

**a. Removal**

**b. Installation**

**INITIAL SETUP:**

APPLICABLE MODELS

All

MATERIALS/PARTS

Cotter pin

REFERENCES (TM)

TM 9-2320-361-10

TM 9-2320-361-20P

EQUIPMENT CONDITION

- Wheels chocked (TM 9-2320-361-10).
- Transfer-to-forward rear propeller shaft removed (all except M36A2) (para. 7-2).
- Intermediate propeller shaft removed (M36A2) (para. 7-3).

## 8-2. PARKING BRAKEDRUM REPLACEMENT (Contd)

### a. Removal

1. Remove spring (3) from lever (6) and bracket (4).

#### NOTE

Mark nut position on threaded end of parking brake cable for installation.

2. Remove nut (2) from threaded end (1) of parking brake cable (11) and slide parking brake cable (11) from eye of lever (6).
3. Loosen jamnut (13) and thread screw (5) several turns into bracket (14).
4. Remove spring (12) from outer brakeshoe (7) and screw (5).
5. Remove jamnut (16), screw (8), spacer(s) (17), lever (6), inner brakeshoe (9), and outer brakeshoe (7) from parking brakedrum (10) and bracket (15).

#### NOTE

Have oil drainage container ready to catch oil.

6. Remove cotter pin (18), nut (19), washer (26), four nuts (25), companion flange (20), grease shield (21), parking brakedrum (10), and deflector (22) from transfer rear output shaft (23). Discard cotter pin (18).
7. Check four studs (24) for cracks, bends, or breaks. If damaged or broken, remove four studs (24) from parking brakedrum (10) and discard studs (24).

### b. Installation

#### NOTE

Perform step 1 only if studs were removed from brakedrum.

1. Install four new studs (24) in parking brakedrum (10).
2. Install deflector (22), brakedrum (10), grease shield (21), and companion flange (20) on transfer rear output shaft (23) with four nuts (25), washer (26), and nut (19). Tighten nut (19) 90-100 lb-ft (122-136 N $\bar{Z}$ m) and install new cotter pin (18).
3. Install inner brakeshoe (9), outer brakeshoe (7), and lever (6) on brakedrum (10).
4. Install spacer(s) (17) and screw (8) on outer brakeshoe (7) and bracket (15) with jamnut (16) until measurement is 0.0625 in, (1.6 mm) between inside edge of brakedrum (10) inner brakeshoe (9).
5. Install spring (12) on adjustment screw (5) and outer brakeshoe (7). Do not tighten jamnut (13).
6. Install threaded end (1) of brake cable (11) through eye of lever (6) and install nut (2) up to marked location on threaded end (1).
7. Install spring (3) on lever (6) and bracket (4).
8. Operate parking brake handle in cab several times ending in released position.
9. Make sure outer brakeshoe (7) and lever (6) rotate easily on screw (8) without side-to-side wobble. Tighten screw (5) as necessary to prevent wobble and tighten jamnuts (13) and (16).

8-2. PARKING BRAKEDRUM REPLACEMENT (Contd)

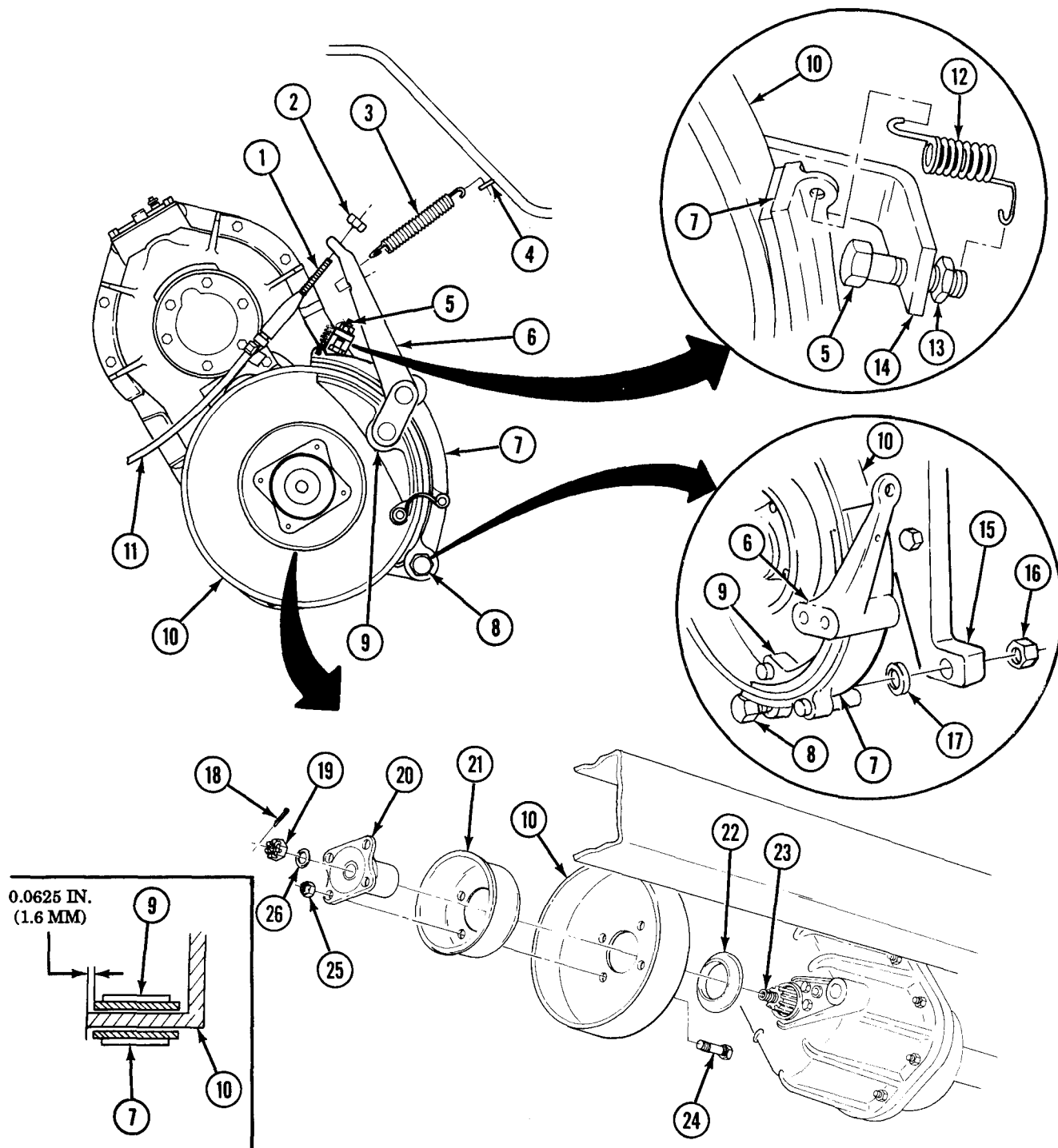

- FOLLOW-ON TASKS:
- Install transfer-to-forward rear axle propeller shaft (all except M36A2) (para. 7-2).
  - Install intermediate propeller shaft (M36A2) (para. 7-3).
  - Parking brake operation test (TM 9-2320-361-10).
  - Adjust parking brakeshoe clearances (para. 8-3).
  - Stow wheel chocks (TM 9-2320-361-10).



**8-3. PARKING BRAKESHOE MAINTENANCE**

This task covers:

- a. Removal**
- b. Disassembly**
- c. Cleaning and Inspection**

- d. Assembly**
- e. Installation**
- f. Clearance Adjustment**

**INITIAL SETUP:**

APPLICABLE MODELS

All

MATERIALS/PARTS

- Four clips
- Lockwasher
- Pin
- Rags (Appendix C, Item 21)
- GAA grease (Appendix C, Item 13)
- Drycleaning solvent (Appendix C, Item 26)

REFERENCES (TM)

- TM 9-2320-361-10
- TM 9-2320-361-20P

EQUIPMENT CONDITION

- Wheels chocked (TM 9-2320-361-10).
- Transfer-to-forward rear axle propeller shaft removed (all except M36A2) (para. 7-2).
- Intermediate propeller shaft removed (M36A2) (para. 7-3).

GENERAL SAFETY INSTRUCTIONS

Keep fire extinguisher nearby when using drycleaning solvent.

**a. Removal**

1. Remove spring (3) from lever (6) and bracket (4).

**NOTE**

Mark nut position on threaded end of parking brake cable for installation.

2. Remove nut (2) from threaded end (1) of parking brake cable (11) and slide parking brake cable (11) from eye of lever (6).
3. Remove spring (12) from outer brakeshoe (7) and screw (5).
4. Remove jamnut (13) and screw (5) from bracket (14).
5. Remove jamnut (16), screw (8), spacer, lever (6), inner brakeshoe (9), and outer brakeshoe (7) from parking brakedrum (10) and bracket (15).

8-3. PARKING BRAKESHOE MAINTENANCE (Contd)

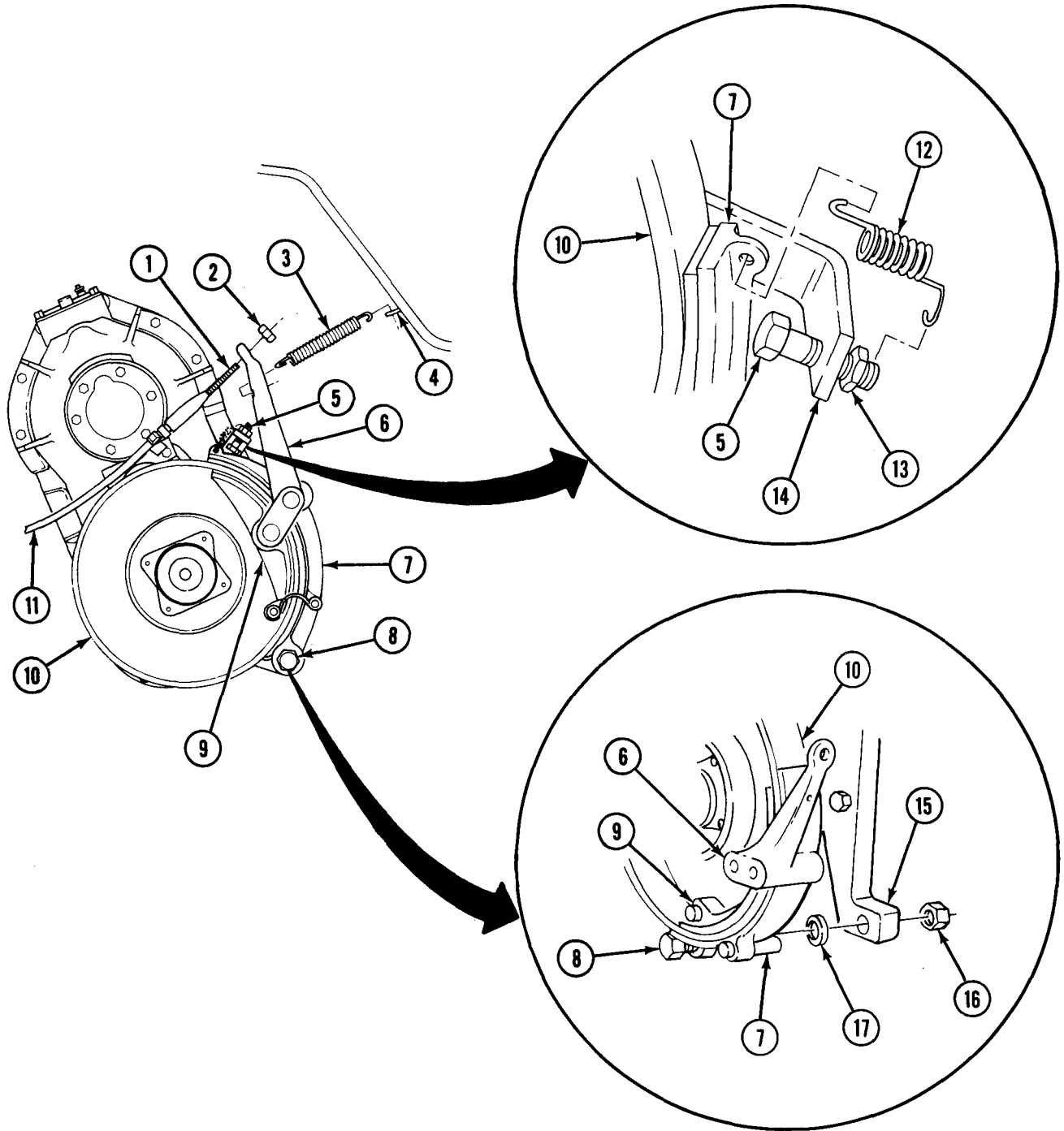

### 8-3. PARKING BRAKESHOE MAINTENANCE (Contd)

#### b. Disassemble

1. Remove two clips (1), spring (6) and two washers (2) and (3) from pins (4) and (5). Discard clips (1).
2. Remove two clips (7) from pins (8) and (11). Discard clips (7).
3. Remove outer brakeshoe (9) from pin (8) and inner brakeshoe (10) from pin (11).
4. Remove nut (18), lockwasher (19), and cam pin (5) from outer shoe (9). Discard lockwasher (19).

#### NOTE

Perform step 5 only if lubrication fittings are damaged.

5. Remove three lubrication fittings (12) from outer shoe (9) and one lubrication fitting (12) and pin (4) from inner shoe (10). Discard pin (4).

#### c. Cleaning and Inspection

#### WARNING

Drycleaning solvent is flammable and will not be used near open flame. Use only in well-ventilated places. Failure to do so may result in injury to personnel.

1. Clean all parts with rag saturated with drycleaning solvent. Remove thick dirt and corrosion. Do not saturate brakeshoe lining or brakedrum with drycleaning solvent.
2. Measure the thickness of brake linings (13) and (15) at most worn point. If thickness is 0.1875 in. (4.76 mm) or less, replace both brakeshoes (9) and (10).
3. Inspect brakeshoes (9) and (10) for broken linings (13) and (15), loose or missing rivets, cracks, or stripped threads. Replace both brakeshoes (9) and (10) if linings (13) and (15) are broken, rivets are loose or missing, brakeshoes (9) and (10) are cracked, or threads are stripped.
4. Inspect lever (14) for cracks, breaks, or loose pins (8) and (11). Replace if cracked, broken, or pins (8) or (11) are loose. Pins (8) and (11) must be perpendicular to lever (14). Clip grooves of pins (11) and (8) must be free of chips and burrs.
5. Slot in cam pin (5) must have square slot. If slot is damaged, replace pin (5).
6. Pin (4) must be tight in brakeshoe (11) and clip groove free of chips and burrs.
7. Inspect springs (20) and (21) for broken or distorted coils. If coils or hook ends are distorted or broken, replace.
8. Inspect jamnuts (17) and (18) for burred flats or stripped threads. Replace if flats are burred or threads are stripped.
9. Inspect screw (16) for breaks, cracks, and crossed or stripped threads. Replace if broken, cracked, or threads are crossed or stripped.

8-3. PARKING BRAKESHOE MAINTENANCE (Contd)

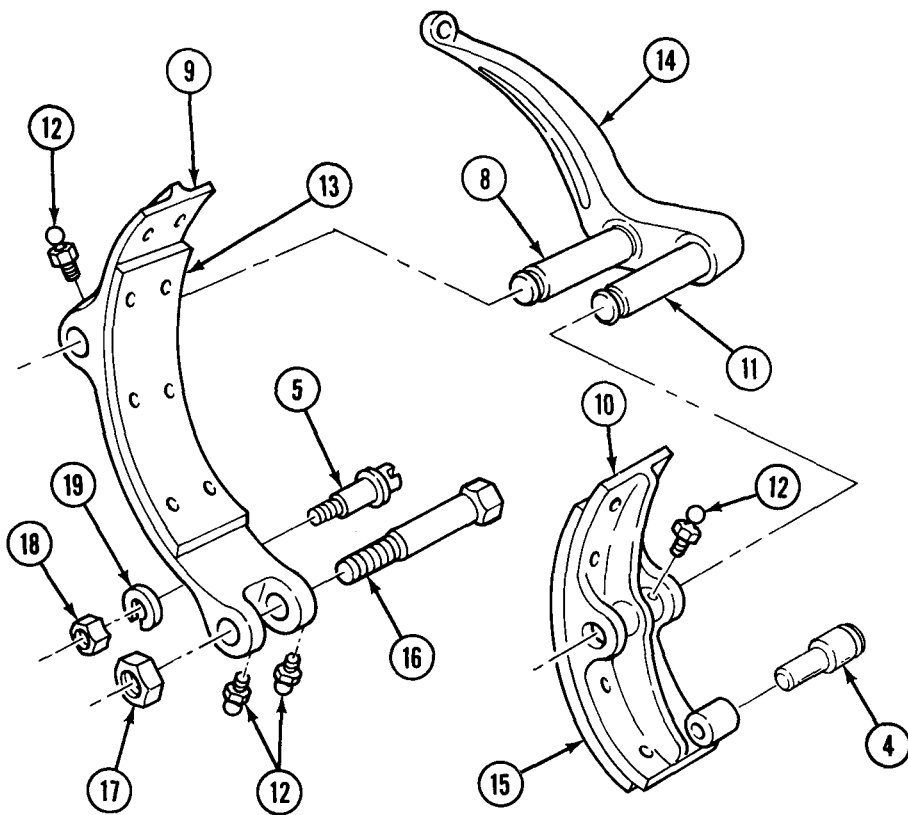
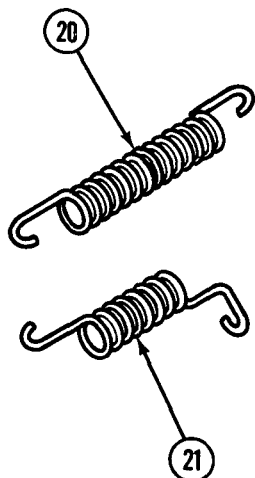
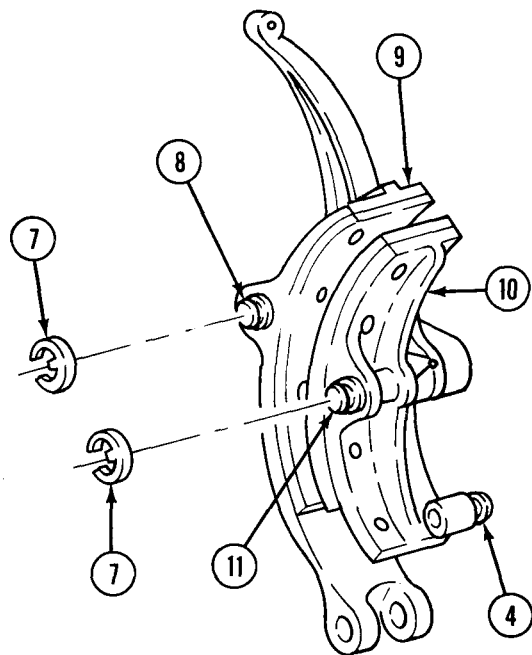
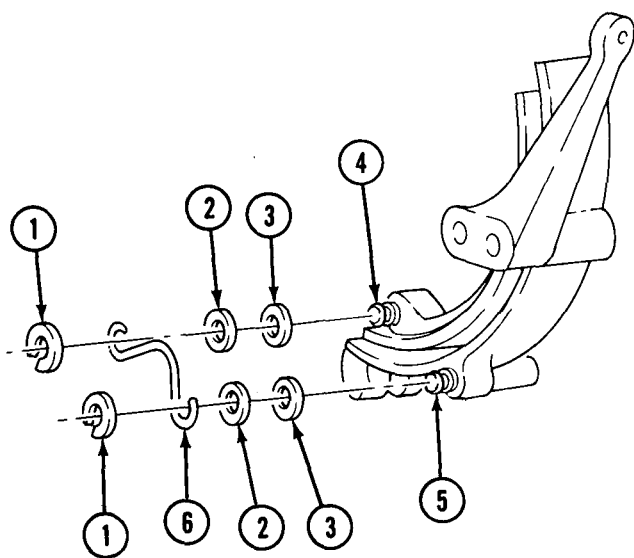

### 8-3. PARKING BRAKESHOE MAINTENANCE (Contd)

#### d. Assembly

#### NOTE

Perform step 1 only if lubrication fittings were removed.

1. Install three lubrication fittings (1) into outer brakeshoe (2) and lubrication fitting (1) and new pin (7) into inner brakeshoe (6).
2. Coat pin (5) with light film of GAA grease and install inner brakeshoe (6) on pin (5) with new clip (8).
3. Coat cam pin (3) with light film of GAA grease and install outer brakeshoe (2) on pin (3) with new clip (8).
4. Coat pin (14) with light film of GAA grease and install pin (14) in outer brakeshoe (2) with new lockwasher (13) and nut (12).
5. Install two washers (11) and (10) and spring (15) on pins (7) and (14) with two new clips (9). Vee of spring (15) must point to lever (4). Turn pin (14) for maximum opening between brakeshoes (2) and (6).

#### e. Installation

1. Install inner brakeshoe (6), outer brakeshoe (2), and lever (4) on brakedrum (22).
2. Install spacer(s) (29) and screw (21) on outer brakeshoe (2) and bracket (27) with jamnut (28) until measurement is 0.0625 in. (1.6 mm) between inside edge of brakedrum (22) and inner brakeshoe (6). Do not tighten jamnut (28).
3. Install adjustment screw (20) and jamnut (25) on bracket (26).
4. Install spring (24) on adjustment screw (20) and outer brakeshoe (2). Tighten jamnut (25).
5. Install threaded end (16) of brake cable (23) through eye of lever (4) and install nut (17) up to marked location on threaded end (16).
6. Install spring (18) on lever (4) and bracket (19).
7. Operate parking brake handle in cab several times ending in released position.
8. Make sure outer brakeshoe (2) and lever (4) rotate easily on screw (21) without side-to-side wobble. Tighten screw (21) as necessary to prevent wobble, and tighten jamnut (28).

8-3. PARKING BRAKESHOE MAINTENANCE (Contd)

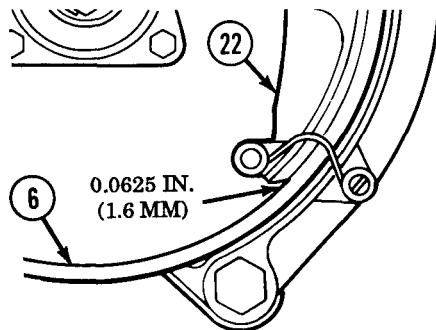
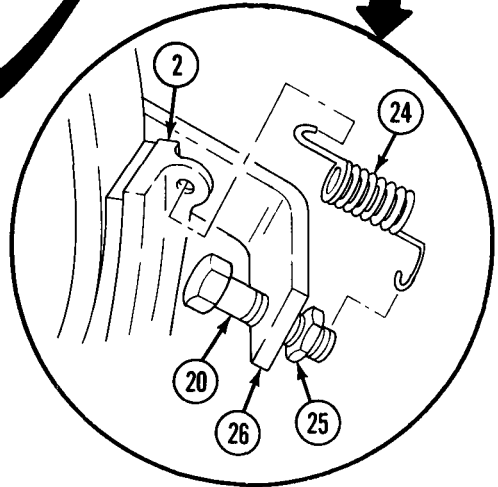
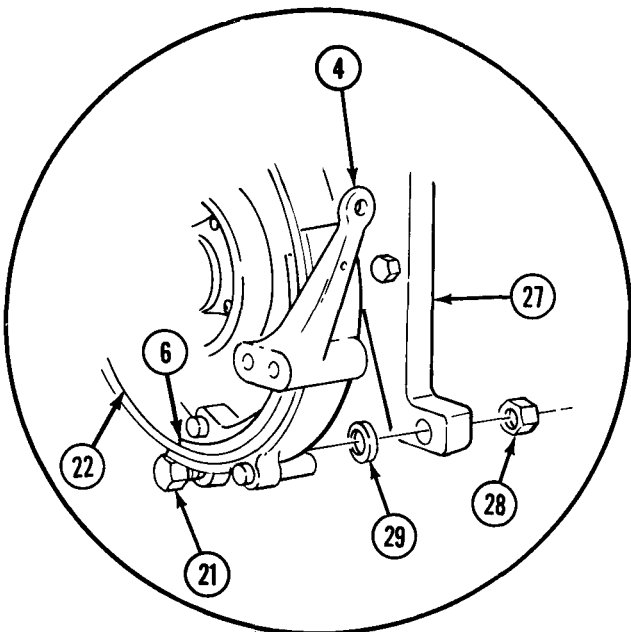
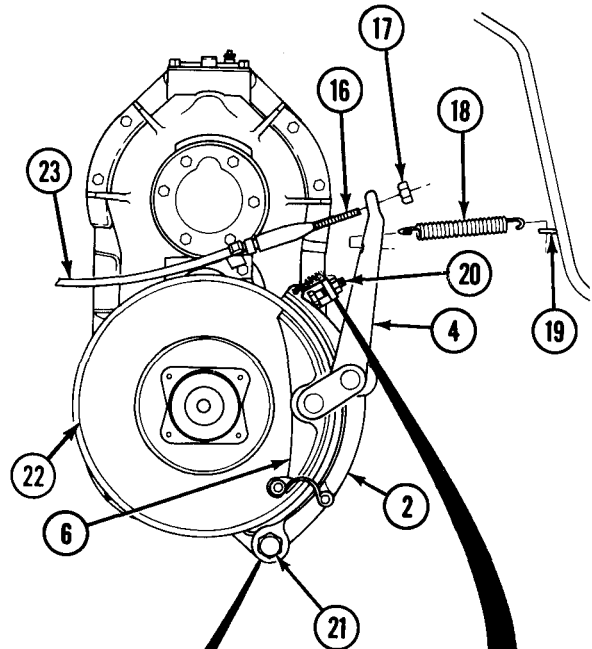
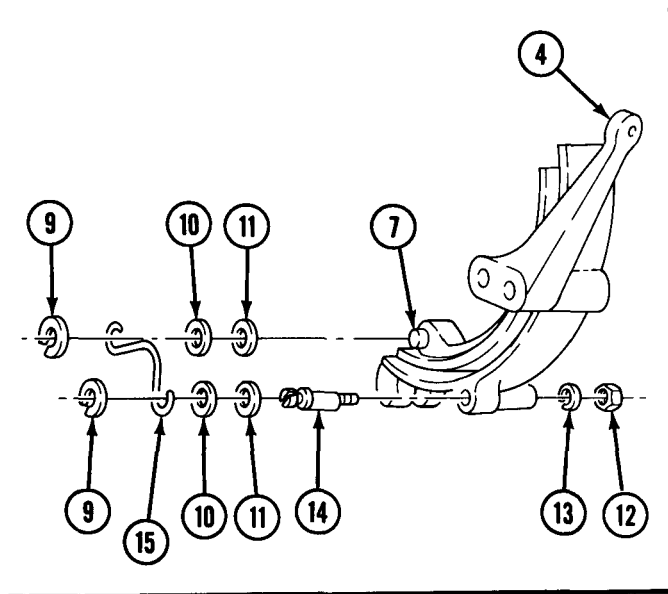

### 8-3. PARKING BRAKESHOE MAINTENANCE (Contd)

#### f. Clearance Adjustment

1. Place parking brake lever (2) in release position. Turn adjustment knob (1) on parking brake lever (2) fully counterclockwise until knob (1) stops turning.
2. Turn screw (11) into or out of bracket (10) to set clearance of outer parking brakeshoe (8) 0.015 in. (.381 mm) from parking brakedrum (7). Check both ends of outer parking brakeshoe (8) for proper clearance.
3. Tighten nut (3) until it just contacts lever (4).
4. Hold slotted pin (5) and loosen nut on other end of pin (5).
5. Turn slotted pin (5) until there is 0.015 in. (.381 mm) clearance between inner parking brakeshoe (6) lining and parking brakedrum (7) at both ends (A and B) at the same time.
6. Apply and release parking brake lever (2) twice. Stop in release position. Recheck clearances.
7. Repeat steps 2 through 6 as necessary to obtain 0.015 in. (.381 mm) clearances.
8. Hold screw (11) and tighten jamnut (9) against bracket (10).
9. Tighten nut on end of slotted pin (5).

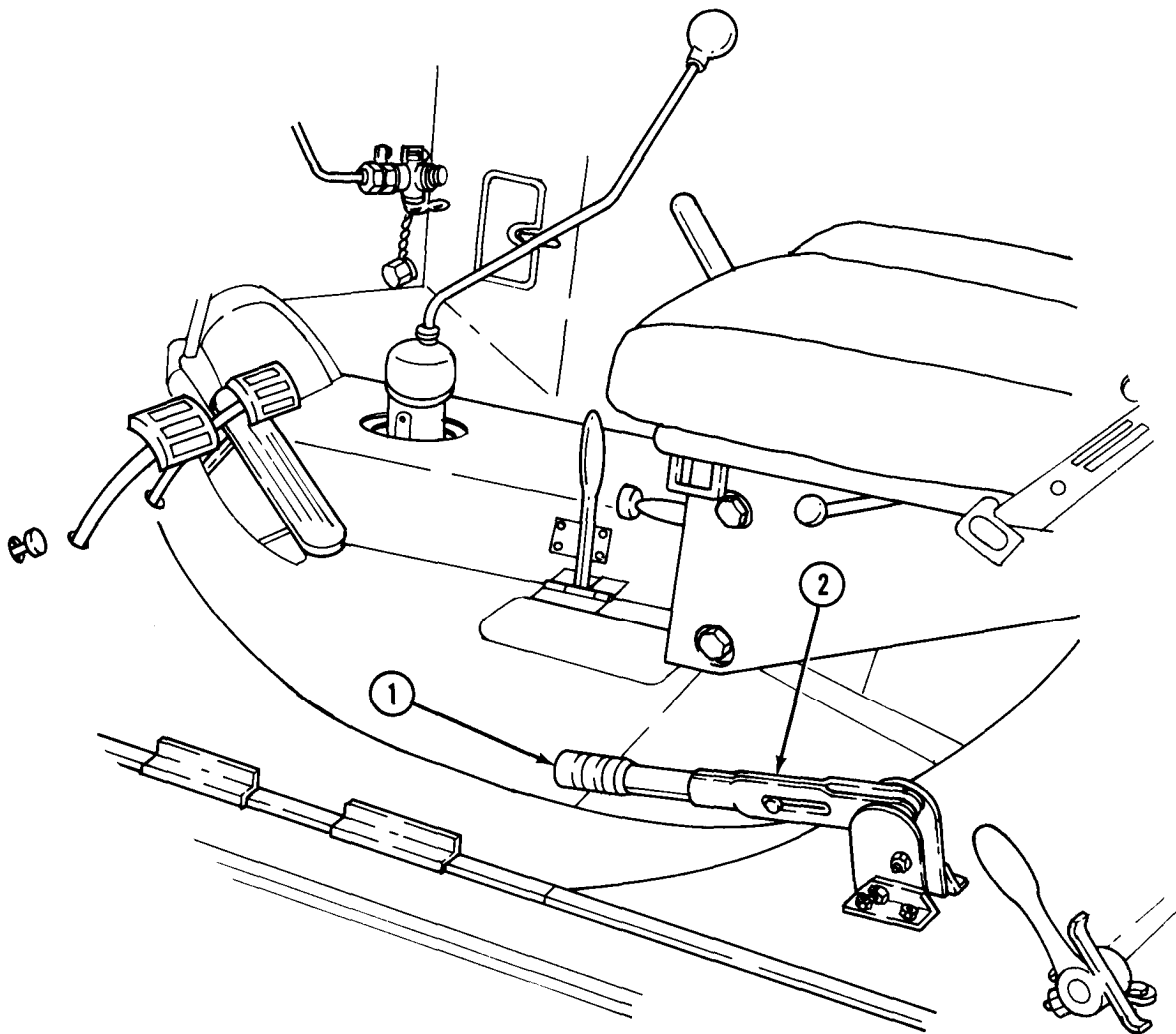

## 8-3. PARKING BRAKESHOE MAINTENANCE (Contd)

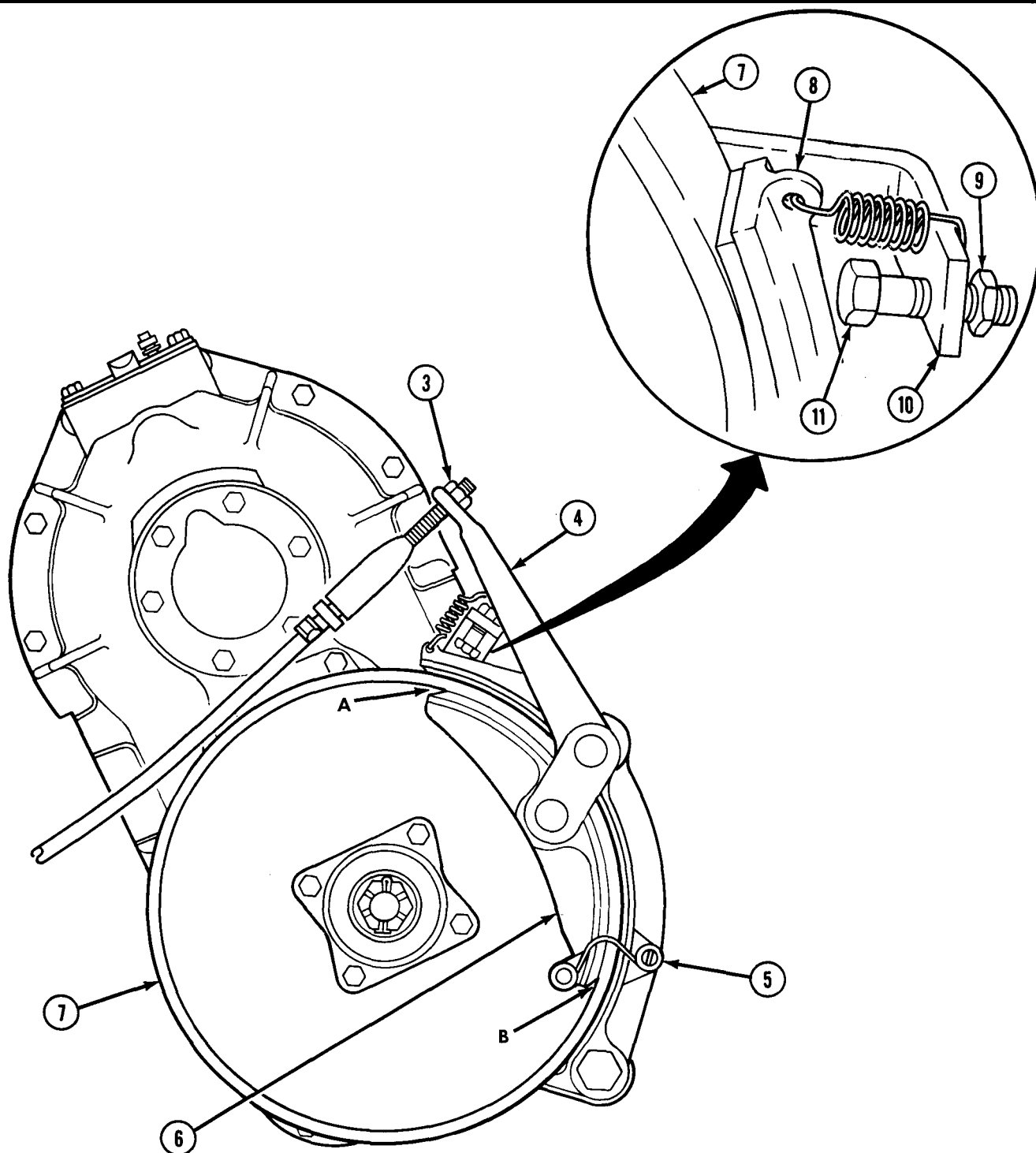

- FOLLOW-ON TASKS:
- Install transfer-to-forward rear axle propeller shaft (para. 7-2).
  - Install intermediate propeller shaft (para. 7-3).
  - Lubricate parking brake (LO 9-2320-209-12-1).
  - Road test vehicle to test parking brake holding power (TM 9-2320-361-10).
  - Stow wheel chocks (TM 9-2320-361-10).



## 8-4. PARKING BRAKE CABLE REPLACEMENT

This task covers:

**a. Removal**

**b. Installation**

**INITIAL SETUP:**

APPLICABLE MODELS

All

MATERIALS/PARTS

Lockwasher

REFERENCES (TM)

TM 9-2320-361-10

TM 9-2320-361-20P

EQUIPMENT CONDITION

- Parking brake lever removed (para. 8-5).
- Remove spare tire if mounted horizontal to rear of toolbox (M275A2 and M342A2) (TM 9-2320-361-10).
- Wheels chocked (TM 9-2320-361-10).

**a. Removal**

1. Remove spring (3) from lever (5) and bracket (4).

**NOTE**

Mark nut position on threaded end of parking brake cable for installation.

2. Remove nut (2) from threaded end (1) of parking brake cable (6) and slide parking brake cable (6) from eye of lever (5).
3. Remove screw (10), lockwasher (9), and clamp (8) from parking brake cable (6) and transfer case (7). Discard lockwasher (9).
4. Remove two nuts (14), screws (11), upper clamp half (12), lower clamp half (15), and parking brake cable (6) from frame (13).
5. Remove two nuts (19), screws (18), clamp (17), spacer (16), and parking brake cable (6) from bracket (20).
6. Remove four nuts (24), screws (21), two clamps (22), and parking brake cable (6) from wear plate (23).

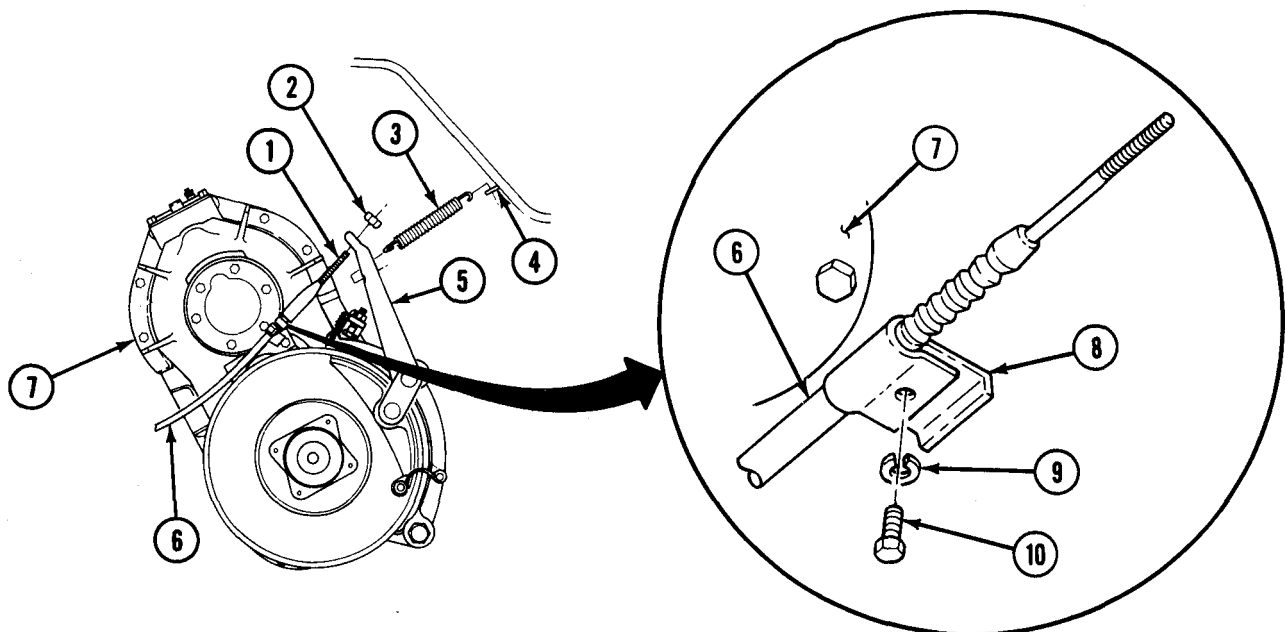

8-4. PARKING BRAKE CABLE REPLACEMENT (Contd)

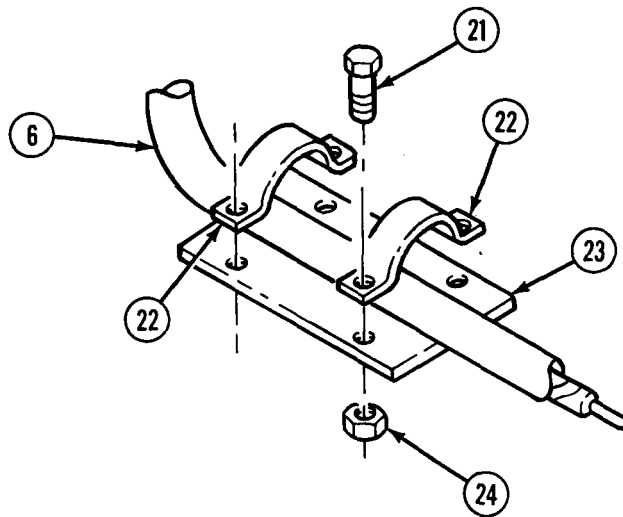
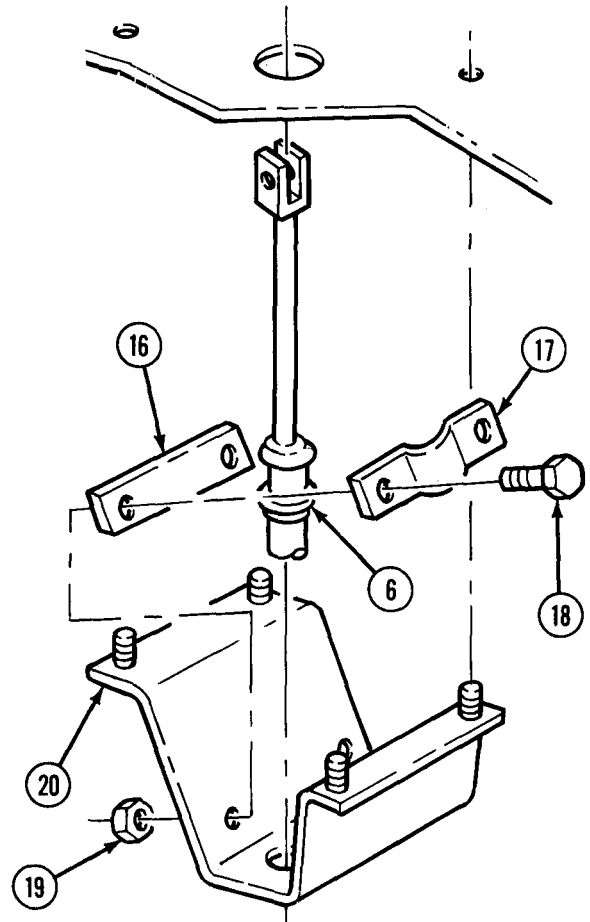
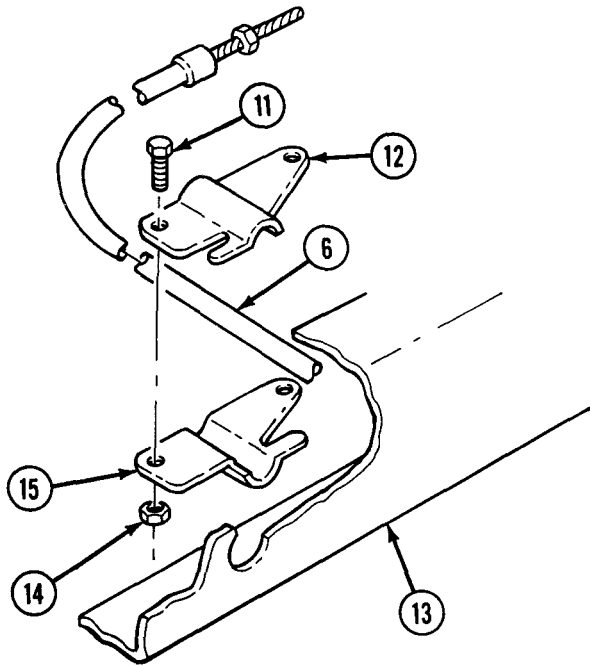

8-4. PARKING BRAKE CABLE REPLACEMENT (Contd)

**b. Installation**

**CAUTION**

Be careful when installing parking brake cable to ensure there are no sharp bends or kinks.

1. Install parking brake cable (4) on bracket (6), with spacer (1) and clamp (2) on groove of parking brake cable (4), with two screws (3) and nuts (5).
2. Install wear plate (9) on parking brake cable (4), approximately 12 in. (30.5 cm) from bracket (6), with clamps (8) and (11), four screws (7), and nuts (10). Do not tighten nuts (10).
3. Install threaded end (12) of brake cable (4) through eye of lever (16), and install nut (13) up to marked location on threaded end (12).
4. Place clamp (18) on parking brake cable (4) and install clamp (18) on transfer case (17) with new lockwasher (19) and screw (20).
5. Install spring (14) on lever (16) and bracket (15).
6. Install parking brake cable (4) on frame (23) with upper clamp half (22), lower clamp half (25), two screws (21), and nuts (24).
7. Adjust position of wear plate (9) to protect parking brake cable (4) from rubbing on edge of toolbox. Tighten nuts (10).

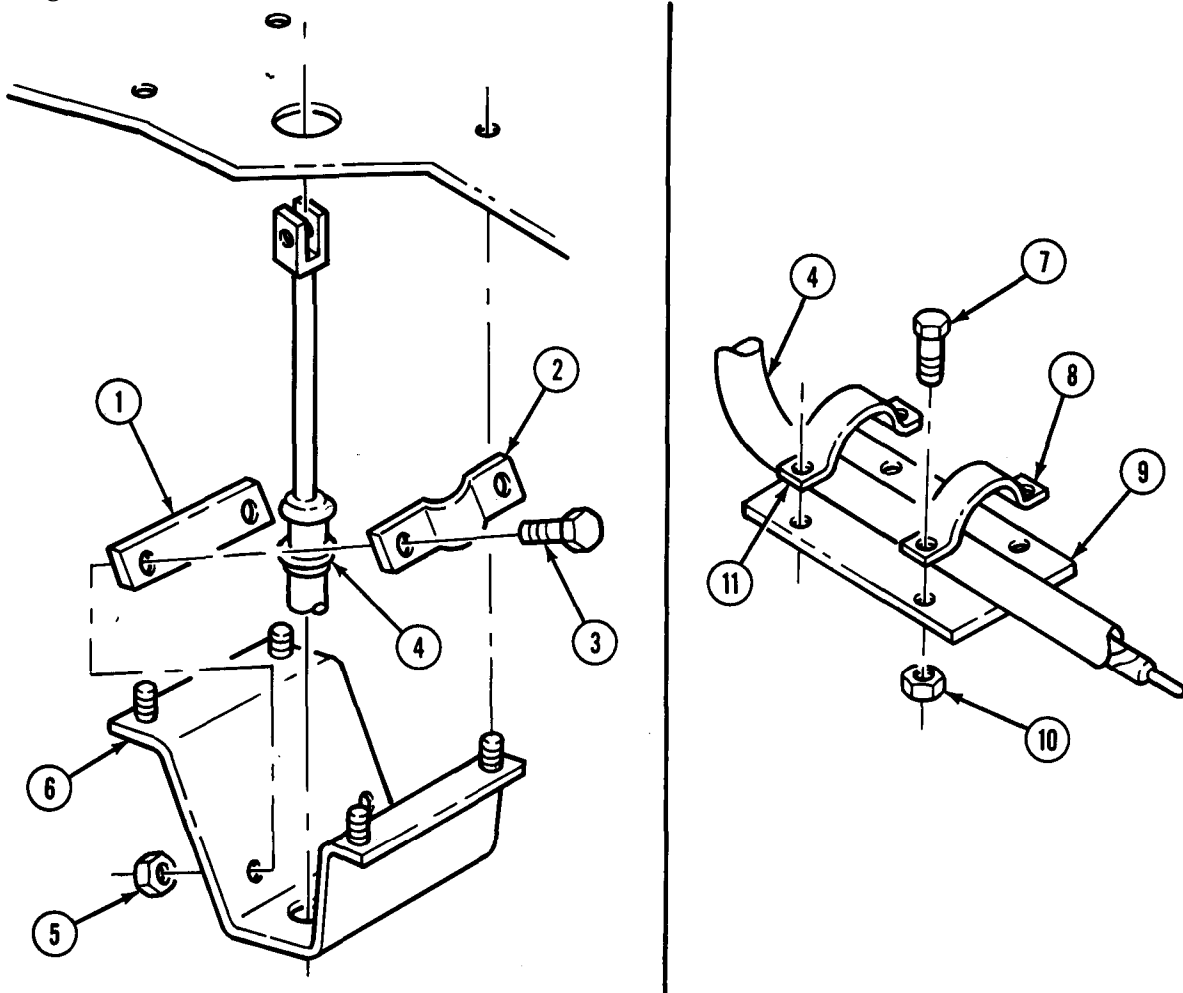

8-4. PARKING BRAKE CABLE REPLACEMENT (Contd)

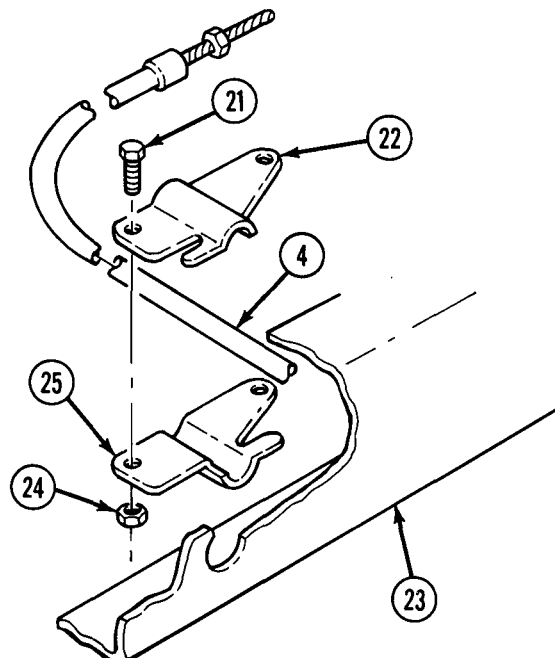
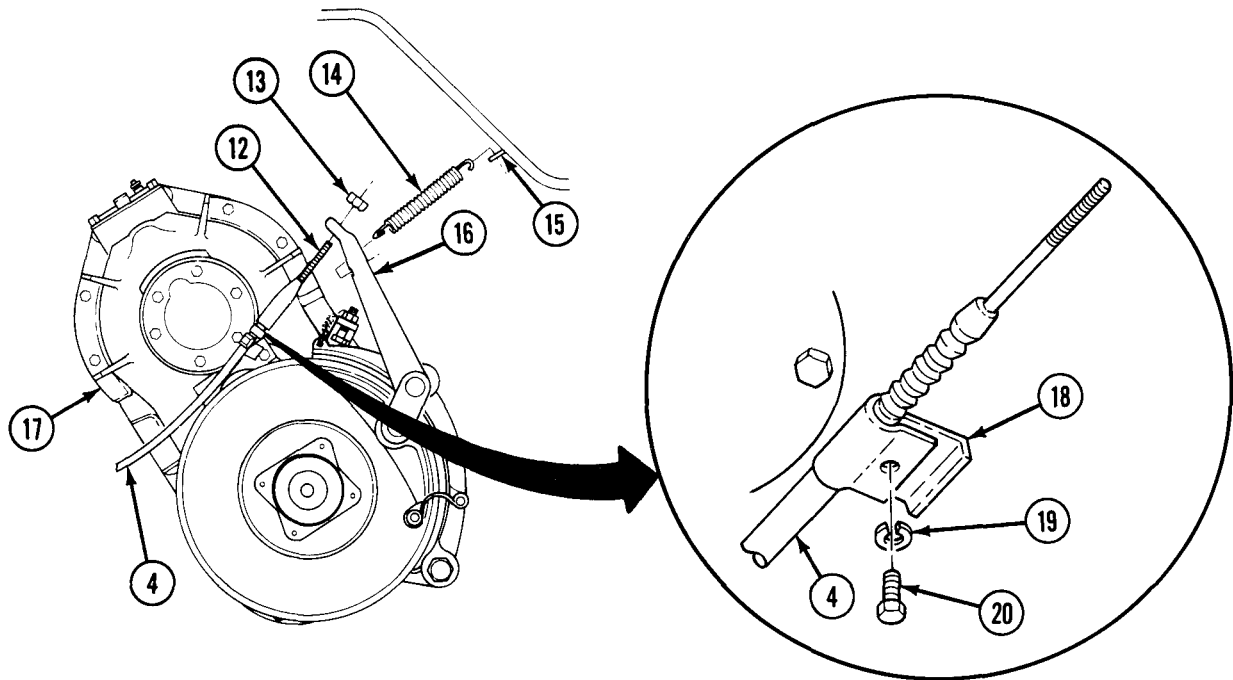

- FOLLOW-ON TASKS:
- Install parking brake lever (para. 8-5 task b.).
  - Check brakeshoe clearance (para. 8-3).
  - Check parking brake lever adjustment (TM 9-2320-361-10).
  - Replace spare tire (if removed) (TM 9-2320-361-10).
  - Stow wheel chocks (TM 9-2320-361-10).

## 8-5. PARKING BRAKE LEVER REPLACEMENT

This task covers:

**a. Removal**

**b. Installation**

INITIAL SETUP:

APPLICABLE MODELS

All

MATERIALS/PARTS

Cotter pin

PERSONNEL REQUIRED

Two

REFERENCES (TM)

TM 9-2320-361-10

TM 9-2320-361-20P

EQUIPMENT CONDITION

Wheels chocked (TM 9-2320-361-10).

### a. Removal

1. Release parking brake if applied (refer to TM 9-2320-361-10).
2. Remove cotter pin (4), washer (3), and clevis pin (15) from cable clevis (12) and parking brake lever (1). Discard cotter pin (4).
3. Remove four nuts (6) and bracket (10) from cab floor (9) and two parking brake lever mounting brackets (7).

**NOTE**

Assistant will help with step 4.

4. Remove nut (11), screw (8), and parking lever (1) from cab floor (9).
5. Remove nut (5) and screw (13) from spacer (2) and two parking brake lever mounting brackets (7).
6. Remove two nuts (14), screws (16), and parking brake lever mounting brackets (7) from parking lever (1).

### b. Installation

**NOTE**

Ensure parking brake lever adjusting knob is turned counter-clockwise to lower link for installation.

1. Install two parking brake lever mounting brackets (7) on parking brake lever (1) with two screws (16) and nuts (14). Do not tighten nuts (14).
2. Install spacer (2) and screw (13) between two parking brake lever mounting brackets (7) and parking brake lever (1) with nut (5). Tighten nuts (5) and (14) so that parking brake lever (1) moves freely.

**NOTE**

Assistant will help with step 3.

3. Install parking brake lever (1) on cab floor (9) with screw (8) and nut (11).
4. Install bracket (10) on cab floor (9) and two parking brake lever mounting brackets (7) with four nuts (6).
5. Connect parking brake lever (1) to cable clevis (12) with clevis pin (15), washer (3), and new cotter pin (4).

8-5. PARKING BRAKE LEVER REPLACEMENT (Contd)

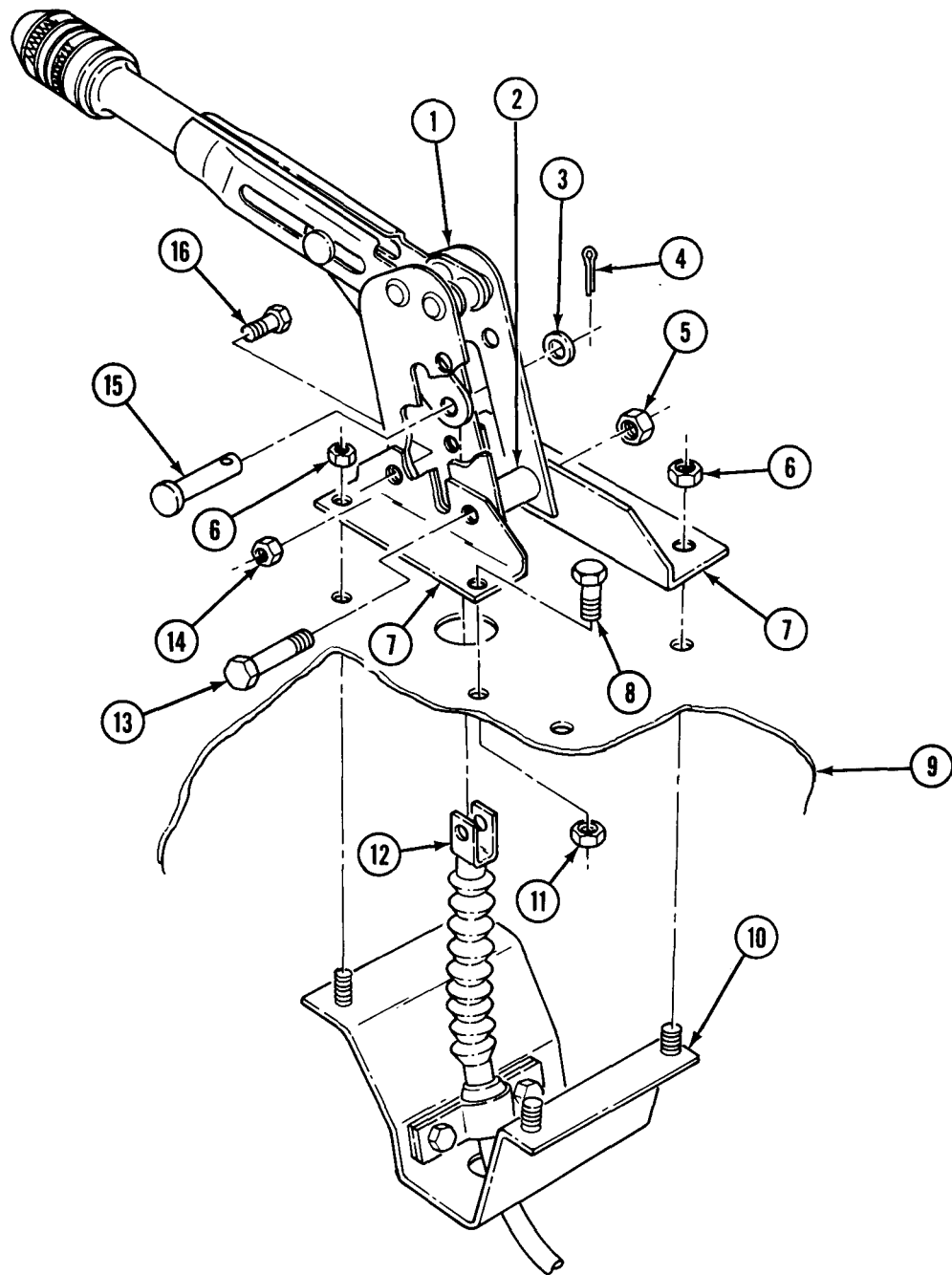

FOLLOW-ON TASKS: • Adjust parking brake lever (TM 9-2320-361-10).  
 • Stow wheel chocks (TM 9-2320-361-10).

Section II. SERVICE BRAKE AND HYDRAULIC SYSTEMS MAINTENANCE

**8-6. SERVICE BRAKE AND HYDRAULIC SYSTEMS MAINTENANCE**

PARA. NO.	TITLE	PAGE NO.
8-7.	Service Brakeshoes Maintenance	8-18
8-8.	Service Brake Adjustment	8-22
8-9.	Hydraulic Wheel Cylinder Replacement	8-24
8-10.	Hydraulic Master Cylinder Replacement	8-26
8-11.	Air-Hydraulic Cylinder Replacement	8-30
8-12.	Service Brake Bleeding	8-32
8-13.	Brake Pedal Lever Replacement	8-36
8-14.	Brake Pedal Adjustment	8-38
8-15.	Hydraulic Brake Line Replacement	8-40
8-16.	Flexible Hydraulic Brake Line Modification	8-42

**8-7. SERVICE BRAKESHOES MAINTENANCE**

This task covers:

- a. Removal
- b. Cleaning and Inspection

- c. Installation

**INITIAL SETUP:**

APPLICABLE MODELS

All

MATERIALS/PARTS

- Engine accessories modification kit  
P/N 8332057
- Two slotted retainers
- Grease (Appendix C, Item 13)
- Drycleaning solvent (Appendix C, Item 26)
- Rags (Appendix C, Item 21)

PERSONNEL REQUIRED

Two

REFERENCES (TM)

- TM 9-2320-361-10
- TM 9-2320-361-20P

EQUIPMENT CONDITION

- Parking brake set (TM 9-2320-361-10).
- Front hubs and brakedrums removed (para. 9-3).

GENERAL SAFETY INSTRUCTIONS

- Do not use a dry brush or compressed air to clean brakeshoes.
- Eyeshield protection is required when using wire brush for cleaning.
- Keep fire extinguisher nearby when using drycleaning solvent.

## 8-7. SERVICE BRAKESHOES MAINTENANCE (Contd)

### **WARNING**

Do not use a dry brush or compressed air to clean brakeshoes. There may be asbestos dust on brakeshoes which can be dangerous to your health if you breathe it. (Brakeshoes must be wet, and soft bristle brush must be used.)

### **NOTE**

- The replacement procedure for front and rear service brakeshoes are done the same way. This procedure covers the front service brakes.
- If any brakeshoes are to be replaced, replace all brakeshoes on both ends of an axle.

### **a. Removal**

1. Remove brakeshoe return spring (24) from brakeshoes (2) and (19).
2. Remove two nuts (7), washers (6), anti-rattle springs (4), washers (3), and upper (long) guide pins (1) from backing plate (5). Discard nuts (7), washers (6), and guide pins (1).
3. Remove two nuts (10), washers (11), lower (short) guide pins (20), and retainer washers (18) from backing plate (5). Discard nuts (10), washers (11), and guide pins (20).
4. Remove two slotted retainers (22) and washers (23) from two anchor pins (21). Discard slotted retainers (22).
5. Remove two brakeshoes (2) and (19), retainer washers (17), and felt washers (14) from anchor pins (21), backing plate (5), and wheel cylinder pushrods (8).
6. Remove two cams (16), springs (15), and adjusting pins (9) from backing plate (5).
7. Remove two nuts (12), washers (13), and anchor pins (21) from backing plate (5).

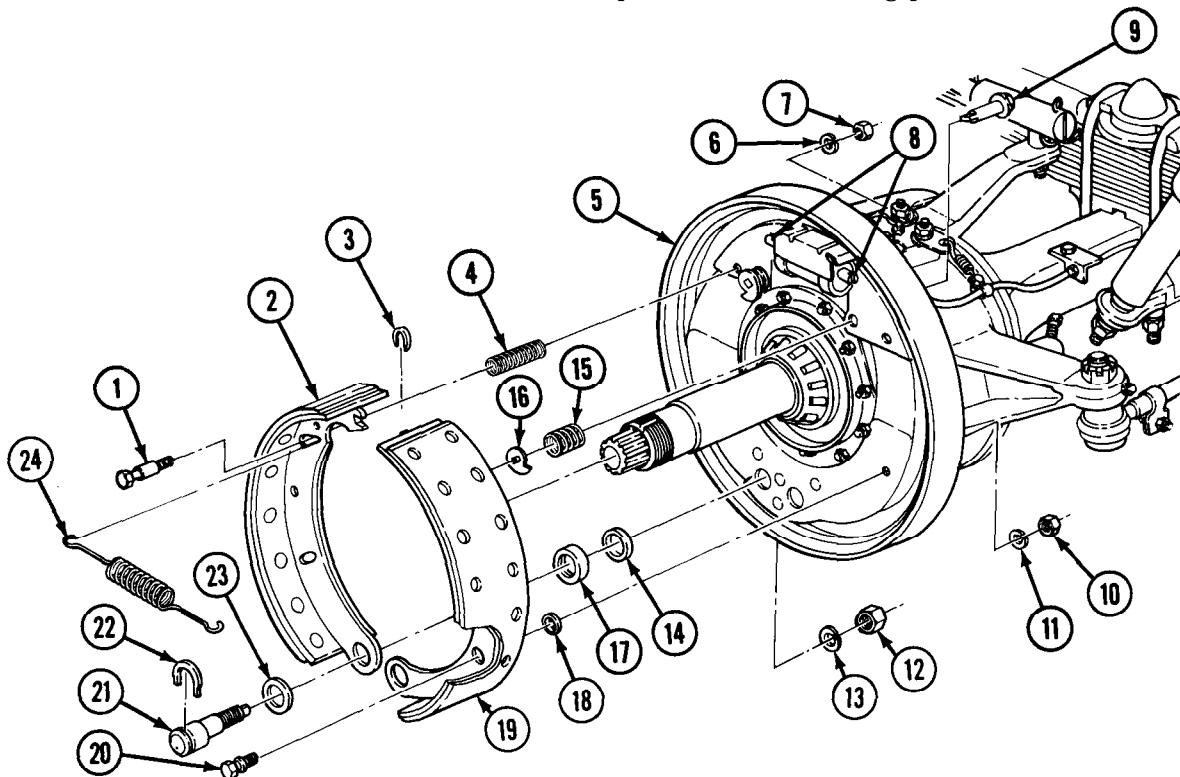



## 8-7. SERVICE BRAKESHOES MAINTENANCE (Contd)

### b. Cleaninig and Inspection

#### WARNING

Eye protection is required when using wire brush for cleaning. Failure to do so may result in injury to personnel.

Drycleaning solvent is flammable and will not be used near open flame. Use only in well-ventilated places. Failure to do so may result in injury to personnel.

1. Wash all parts, except brakeshoes (2) and (23), in drycleaning solvent and wipe dry with clean rag. Clean outer brakeshoe side of backing plate (5) with rag saturated in drycleaning solvent and wipe dry.
2. Measure top, middle, and bottom thickness of brakeshoes (2) and (23). If minimum thickness is 0.33 in. (8.33 mm) or less, replace.
3. Inspect backing plate (5) for cracks, breaks, and elongated holes. If backing plate (5) is broken, cracked, or holes are elongated, replace. If rear axle backing plate (5) is damaged, replace rear axle housing.
4. Inspect anchor plate (15) for loose or missing rivets (14). If any rivets (14) are loose or missing, replace backing plate (5).
5. Inspect anchor pins (27) for cracks, looseness, and chipped or broken retaining clip slots (26). If anchor pins (27) are cracked, loose in backing plate (5), or retaining clip slots (26) are damaged, replace.
6. Inspect wheel cylinder (7) for cracks, leaks, torn boots (6), and bent or broken pushrods (10). If cracked, leaking, boots (6) are torn, or pushrods (10) are bent or broken, replace wheel cylinder (7).
7. Inspect cams (20), springs (19), and adjusting pins (11) for cracks, bends, or breaks. If cracked, bent, or broken, replace.
8. Inspect return spring (30) and anti-rattle springs (4) for breaks. bends. or distorted coils. If broken, bent, or coils are distorted, replace.

### c. Installation

1. Mark ends of new or old anchor pins (27) with center punch indicating highest cam lobe position.
2. Apply light coat of grease on backing plate (5) where brakeshoes (2) and (23) may rub.

#### NOTE

Perform steps 3 and 4 if anchor pins and cams have been removed.

Final tightening of cam nuts and anchor pin nuts is done in brakeshoe adjustment.

3. Install felt washers (18), retainer washers (21), and anchor pins (27) on backing plate (5) with two washers (17) and nuts (16). Do not tighten nuts (17).
4. Install two adjusting pins (11), springs (19), and cams (20) on backing plate (5). Peen ends of two adjusting pins (11) securely against cams (20) to hold in place.
5. Turn anchor pins (27) so that center punch marks (25) are close together.
6. Set cam (20) so that tip points down.

#### NOTE

Brakeshoes must be a matched set on both ends of axle.

7. Install two brakeshoes (2) and (23) on anchor pins (27) against wheel cylinder pushrods (10) and against backing plate (5) with two retainer washers (22), new lower (short) guide pins (24), washers (13), and nuts (12).

## 8-7. SERVICE BRAKESHOES MAINTENANCE (Contd)

8. Install two anti-rattle springs (4) and washers (3) between two brakeshoes (2) and (23) and backing plate (5) with two upper (long) guide pins (1), washers (8), and nuts (9).
9. Tighten upper guide pin nuts (9) 19-24 lb-ft (26-33 NŹm) and lower guide pin nuts (12) 11-16 lb-ft (15-22 NŹm).
10. Install two retainer washers (29) and new retaining clips (28) on anchor pins (27). Squeeze retaining clips (28) into slots of anchor pins (27).

### NOTE

Ensure brakeshoes are still positioned against wheel cylinder pushrods after brakeshoe return spring is installed.

11. Install brakeshoe return spring (30) on two brakeshoes (2) and (23).

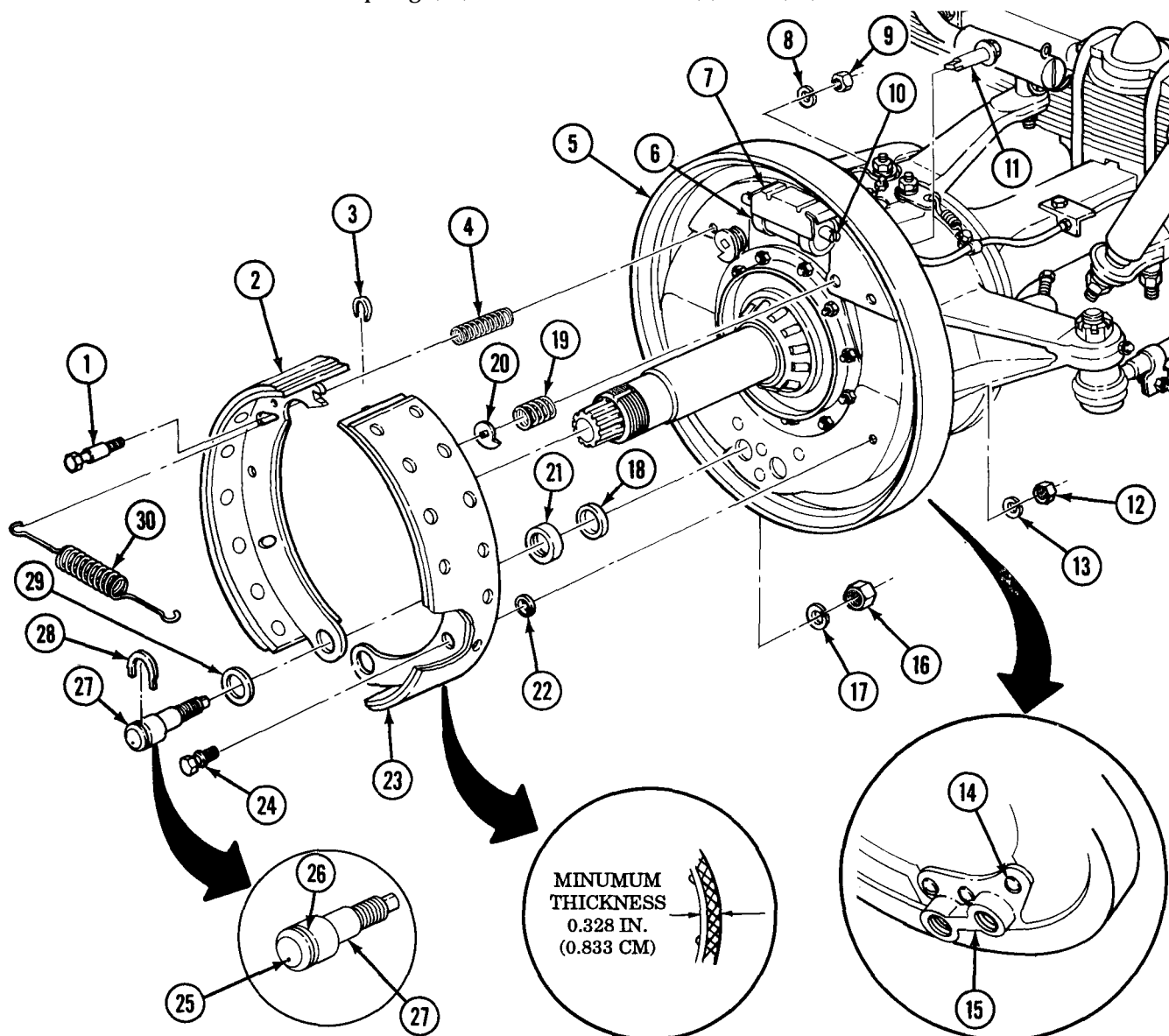

- FOLLOW-ON TASKS:
- Replace hub and brakedrums (para. 9-3).
  - Perform service brake adjustment (para. 8-8).

## 8-8. SERVICE BRAKE ADJUSTMENT

This task covers:

### Service Brake Adjustment

**INITIAL SETUP:**

APPLICABLE MODELS

All

MATERIALS/PARTS

Lockwasher

REFERENCES [TM]

TM 9-2320-361-10

TM 9-2320-361-20P

EQUIPMENT CONDITION

Parking brake set (TM 9-2320-361-10).

Front or rear wheels removed (para. 9-2).

Adjust wheel bearing (para. 9-5).

**NOTE**

- The adjustment procedure for front and rear brakes is done the same way. This procedure covers the front brakes.
- Allow brakes to cool before adjusting.

### Service Brake Adjustment

1. Remove nut (1), lockwasher (2), and inspection slot cover (3) from brakedrum (4). Discard lockwasher (2).
2. Turn brakedrum (4) to position inspection slot (5) at 8 o'clock location.
3. Loosen jamnut (8) on anchor pin (9) one full turn.
4. Turn anchor pin (9) clockwise or counterclockwise until gap between brakeshoe lining (13) and inner brakedrum surface (12) measures .010 in. (.25 mm). Tighten jamnut (8) on anchor pin (9) 80-110 lb-ft (109-149 N·m).
5. Turn brakedrum (4) to position inspection slot (5) at 11 o'clock location.
6. Turn cam stud (7) clockwise until gap between brakeshoe lining (13) and inner brakedrum surface (12) measures .020 in. (.50 mm).
7. Turn brakedrum (4) to position inspection slot (5) at 5 o'clock location.
8. Loosen jamnut (10) on anchor pin (11) one full turn.
9. Turn anchor pin (11) clockwise or counterclockwise until gap between brakeshoe lining (13) and inner brakedrum surface (12) measures .010 in. (.25 mm). Tighten jamnut (10) on anchor pin (11) 80-110 lb-ft (109-149 N·m).
10. Turn brakedrum (4) to position inspection slot (5) at 1 o'clock location.
11. Turn cam stud (6) counterclockwise until gap between brakeshoe lining (13) and inner brakedrum surface (12) measures .020 in. (.50 mm).
12. Install inspection slot cover (3) on brakedrum (4) with new lockwasher (2) and nut (1).
13. Turn brakedrum (4) by hand and turn cam stud (6) counterclockwise until brakedrum (4) drags. Loosen cam stud (6) until brakedrum (4) slightly drags.
14. Turn brakedrum (4) by hand and turn cam stud (7) clockwise until brakedrum (4) drags. Loosen cam stud (7) until brakedrum (4) slightly drags.
15. Repeat steps 1 through 14 to do service adjustment of other wheel on axle.

**8-8. SERVICE BRAKE ADJUSTMENT (Contd)**

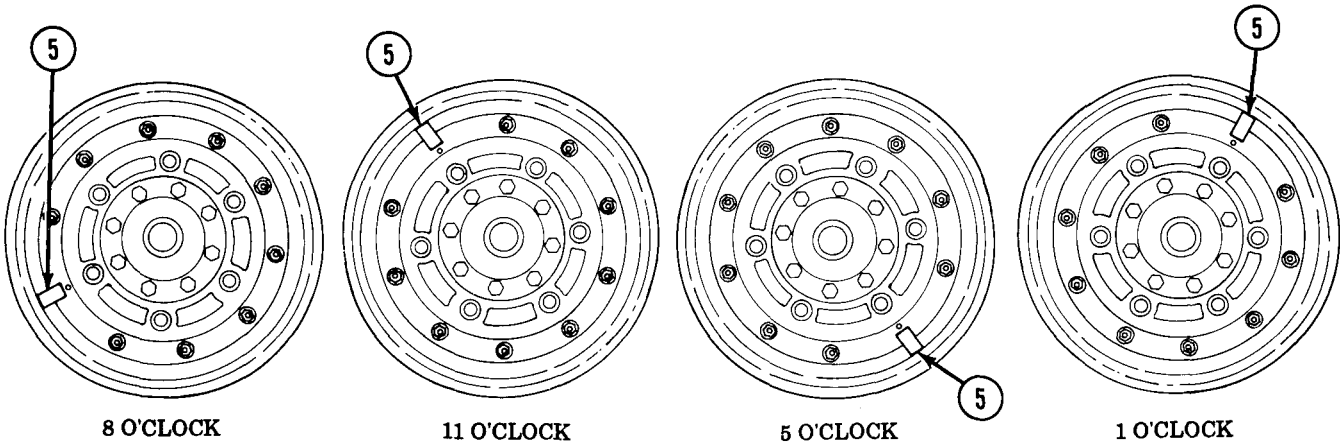
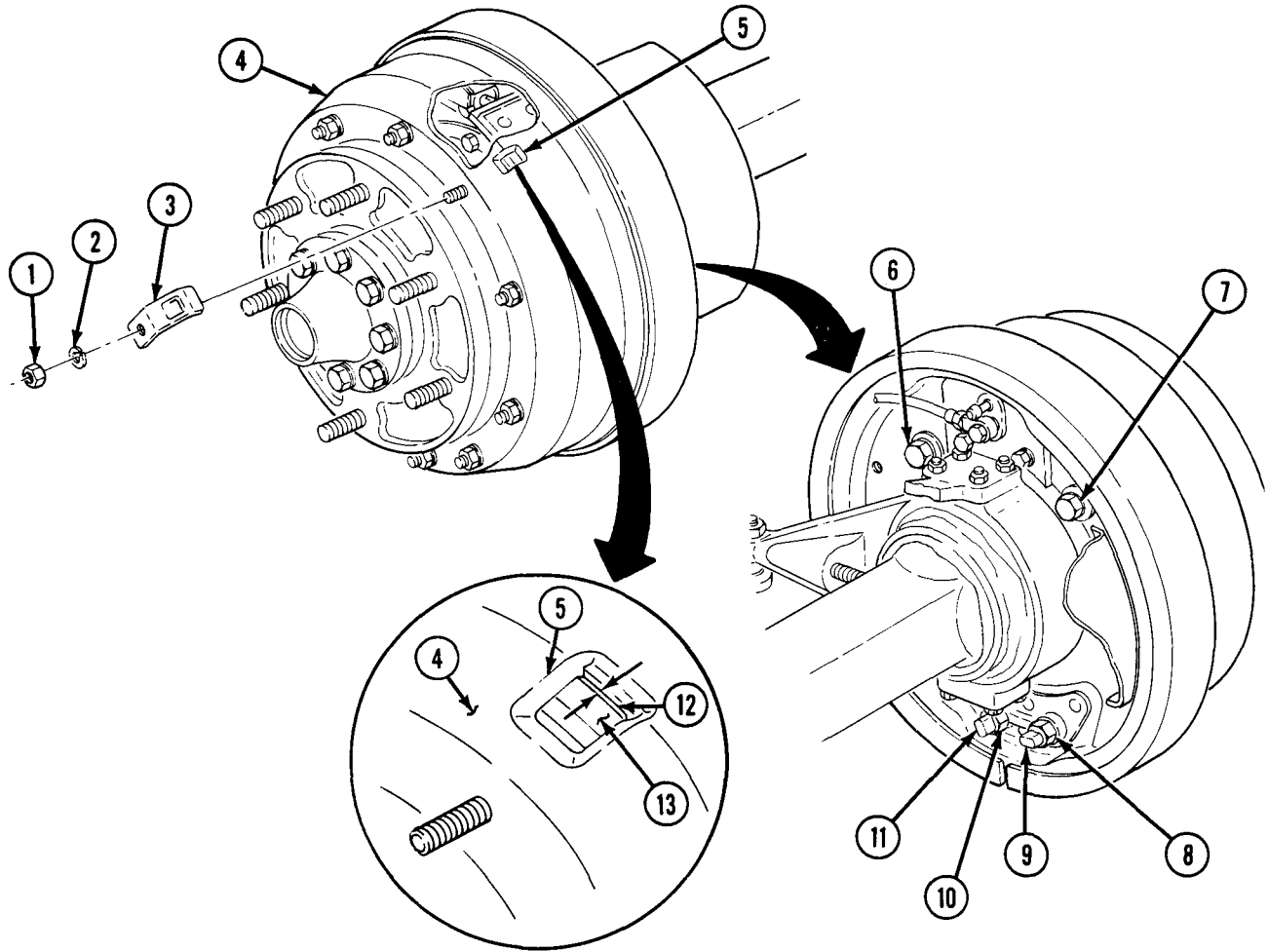

FOLLOW-ON TASK Install front or rear wheels (para. 9-2).

**8-9. HYDRAULIC WHEEL CYLINDER REPLACEMENT**

This task covers:

**a. Removal**

**b. Installation**

**INITIAL SETUP:**

APPLICABLE MODELS

All

MATERIALS/PARTS

Two lockwashers  
 Two washers  
 Cap and plug set (Appendix C, Item 8)

REFERENCES (TM)

LO 9-2320-209-12-1  
 TM 9-2320-361-10  
 TM 9-2320-361-20P

EQUIPMENT CONDITION

- Parking brake set (TM 9-2320-361-10).
- Remove front or rear hubs and drums (para. 9-3 or 9-4).

**CAUTION**

Cap or plug all openings immediately after disconnecting brake lines and hoses to prevent contamination. Failure to do so may result in internal parts damage.

**NOTE**

Front and rear wheel cylinders are replaced the same way. This procedure covers the left front.

1. Remove brakeshoe return spring (9) from two brakeshoes (7) and (13).

**NOTE**

Have drainage container ready to catch brake fluid.

2. Remove brake line screw (2), two washers (1), and hose connector (3) from wheel cylinder (10).
3. Remove two screws (4) and lockwashers (5) from backing plate (6) and wheel cylinder (10). Discard lockwashers (5).
4. Slide brakeshoes (7) and (13) off slotted pushrods (8) and remove wheel cylinder (10) and dustshield (12) from backing plate (6).
5. Remove, clean, and inspect bleeder screw (11) from wheel cylinder (10). If damaged, replace.

**b. Installation**

1. Install bleeder screw (11) into wheel cylinder (10). Tighten bleeder screw (11) 120-168 lb-in. (14-19 NŹm).
2. Install dustshield (12) and wheel cylinder (10) on backing plate (6) with slotted pushrods (8) placed in brakeshoes (7) and (13) slots.
3. Install two new lockwashers (5) and screws (4) into wheel cylinder (10) and backing plate (6). Tighten screws (4) 27-35 lb-ft (37-48 NŹm).
4. Install hose connector (3) to wheel cylinder (10) with two washers (1) and brake line screw (2). Tighten screw (2) 65 lb-ft (88 NŹm).
5. Install brakeshoe return spring (9) on two brakeshoes (7) and (13).

8-9. HYDRAULIC WHEEL CYLINDER REPLACEMENT (Contd)

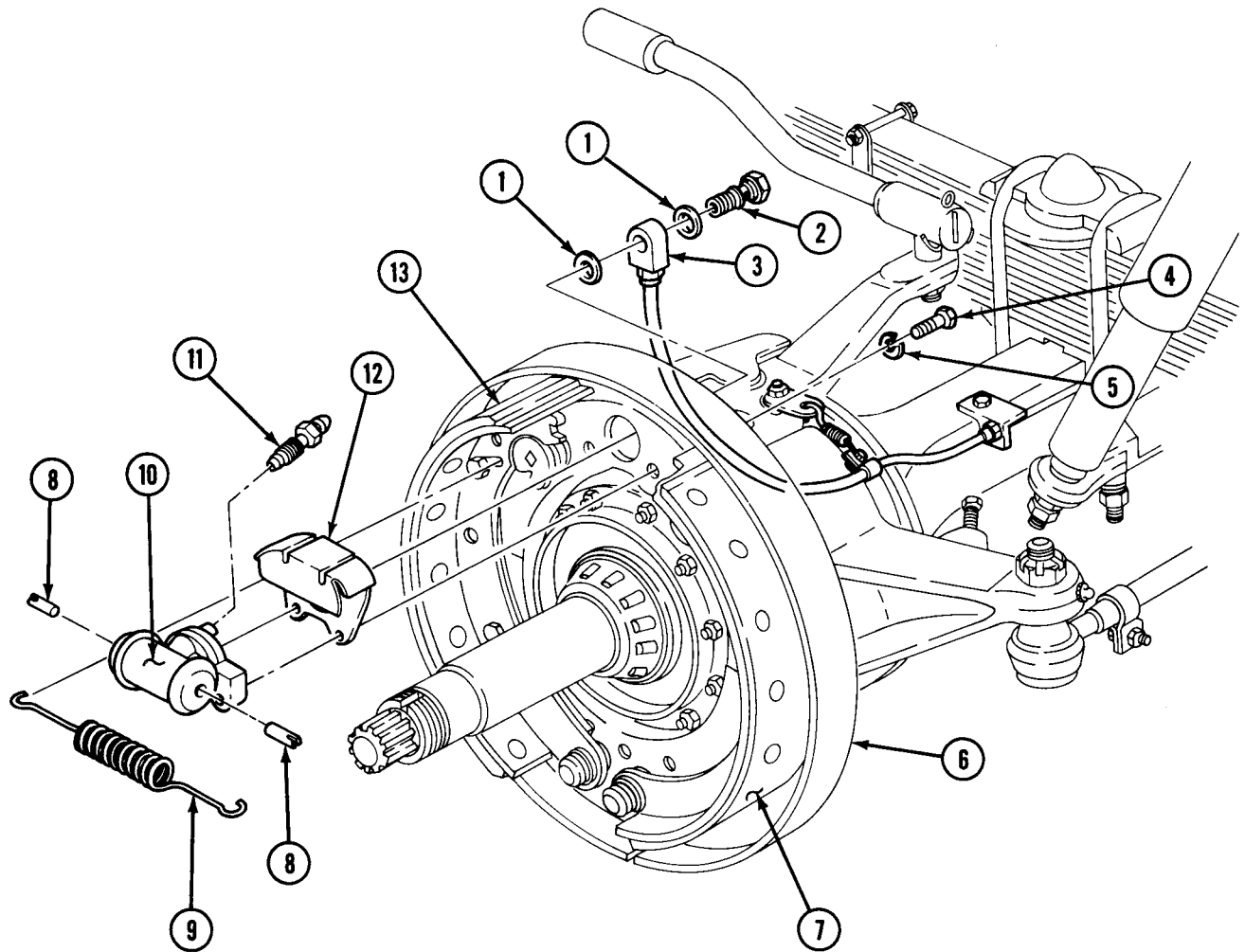

- FOLLOW-ON TASKS:
- Install front or rear hubs and drums (para. 9-3 or 9-4).
  - Bleed service brakes (para. 8-12).
  - Adjust service brakes (para. 8-8).

**8-10. HYDRAULIC MASTER CYLINDER REPLACEMENT**

This task covers:

- a. Internal Leakage Test
- b. Removal

c. Installation

**INITIAL SETUP:**

APPLICABLE MODELS

All

MATERIALS/PARTS

- Cotter pin
- Two gaskets
- Four lockwashers
- Screw-assembled lockwasher
- Antiseize tape (Appendix C, Item 27)
- Cap and plug set (Appendix C, Item 8)
- Plug P/N 218-5154
- Brake fluid (Appendix C, Item 7)

PERSONNEL REQUIRED

Two

REFERENCES (TM)

- LO 9-2320-209-12-1
- TM 9-2320-361-10
- TM 9-2320-361-20P

EQUIPMENT CONDITION

- Parking brake set (TM 9-2320-361-10).
- Adjust brake pedal (para. 8-14).
- Hydraulic hoist pump propeller shaft (M342A2) removed (para. 12-14).
- Hydraulic hoist pump control linkage (M342A2) removed (para. 13-22).
- Transmission PTO shift linkage (M342A2) removed (para. 13-20).

**CAUTION**

When disconnecting hydraulic lines and hoses, plug all openings to prevent dirt from entering and causing internal parts damage. Remove caps and plugs prior to installation.

**a. Internal Leakage Test**

1. Remove screw-assembled lockwasher (6) from brace (2) and open access door (1). Discard screw-assembled lockwasher (6).
2. Disconnect line (3) from adapter (5).
3. Remove two screws (8) and shield (9) from air-hydraulic cylinder (7).

**NOTE**

Have drainage container ready to catch brake fluid.

4. Remove line (10) and two gaskets (11) from adapter (12) and adapter (13). Discard gaskets (11).

**NOTE**

Have plug ready to replace adapter before removing adapter.

5. Remove adapter (12) from master cylinder (4) and quickly install plug (14).
6. Make sure master cylinder (4) is filled with brake fluid 0.5 in. (12.7 mm) from top (refer to LO 9-2320-209-12-1).

**NOTE**

Assistant will help with steps 7 and 8.

7. Measuring distance alongside of brake pedal (15), step down slowly but firmly on brake pedal (15). Maintain steady firm pressure for 30 seconds.
8. Brake pedal (15) should not move more than 0.125-0.25 in. (3.18 -6.35 mm).
9. If brake pedal (15) moves more than 0.125-0.25 in. (3.18 -6.35 mm) in 30 seconds. there is an internal leak. Replace master cylinder (4).

**8-10. HYDRAULIC MASTER CYLINDER REPLACEMENT (Contd)**

**NOTE**

Have drainage container ready to catch brake fluid.

10. Remove plug (14) and install adapter (12) in master cylinder (4).
11. Install line (10) on adapter (12) and adapter (13).
12. Install shield (9) on air-hydraulic cylinder (7) with two screws (8).
13. Fill master cylinder (4) 0.5 in. (12.7 mm) from top (LO 9-2320-209-12-1).
14. Connect line (3) on adapter (5).
15. Close access door (1) and secure to brace (2) with new screw-assembled lockwasher (6).

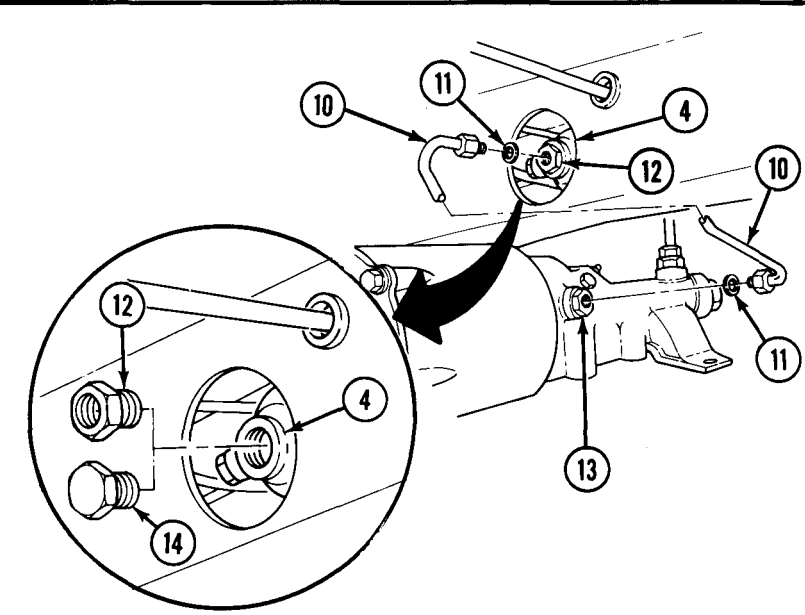
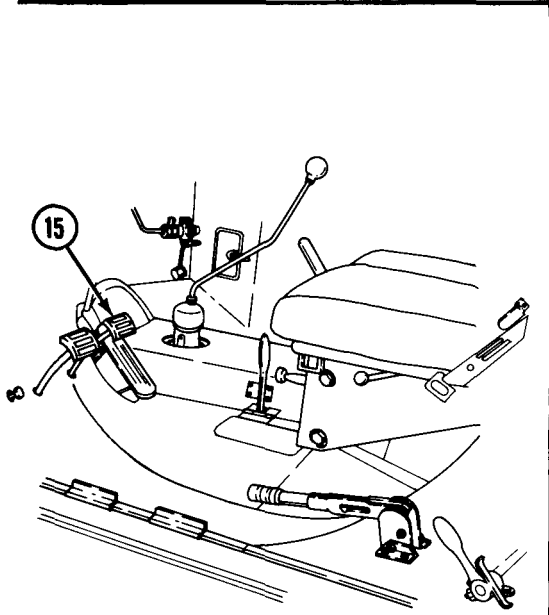
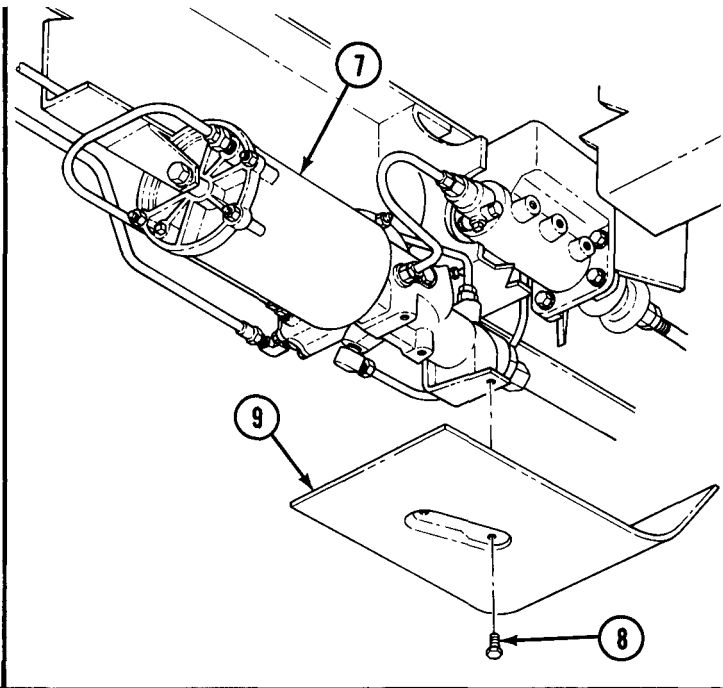
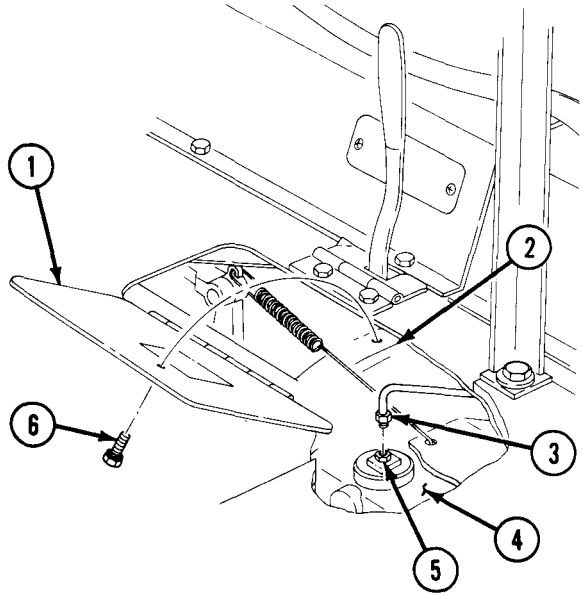



## 8-10. HYDRAULIC MASTER CYLINDER REPLACEMENT (Contd)

### CAUTION

When disconnecting hydraulic lines and hoses, plug all openings to prevent dirt from entering and causing internal parts damage. Remove plugs prior to installation.

### b. Removal

1. Remove screw-assembled lockwasher (6) from brace (2) and open access door (1).
2. Disconnect line (4) from adapter (5).
3. Remove two screws (8) and shield (9) from air-hydraulic cylinder (7).
4. Remove two screws (10) from bracket (20) and master cylinder (2). Push bracket (20) away from master cylinder (3).
5. Remove spring (14) from clevis pin (11) and bracket (13).
6. Remove cotter pin (15) from clevis pin (11). Discard cotter pin (15).

### **NOTE**

Brake pedal must be supported in full extended position for ease when installing master cylinder.

7. Scribe or measure position of jamnut (17).
8. Loosen jamnut (17) and remove clevis pin (11) and yoke (16) from brake pedal lever (12).
9. Remove pushrod (18) and boot (19) from master cylinder (3).

### **NOTE**

Have drainage container ready to catch brake fluid.

10. Remove line (21) and two gaskets (22) from adapters (23) and (24). Discard gaskets (22).
11. Remove four screws (25), lockwashers (26), and master cylinder (3) from bracket (27). Discard lockwashers (26).
12. Remove adapter (23) and adapter (5) from master cylinder (3).

### c. Installation

### **NOTE**

All male pipe threads must be wrapped with antiseize tape before installation.

1. Install adapter (23) and adapter (5) on master cylinder (3).
2. Install master cylinder (3) on bracket (27) with four new lockwashers (26) and screws (25).
3. Install boot (19) and pushrod (18) on master cylinder (3).
4. Install two new gaskets (22) and line (21) on adapters (23) and (24).
5. Install yoke (16) on pushrod (18) to measured distance or scribed mark, ensure yoke (16) forked end aligns with brake pedal lever (12).
6. Tighten jamnut (17) on pushrod (18).
7. Align brake pedal lever (12) with yoke (16) holes and install with clevis pin (11) and new cotter pin (15).
8. Install spring (14) on clevis pin (11) and bracket (13).
9. Install bracket (20) on master cylinder (3) with two screws (10).
10. Install shield (9) on air-hydraulic cylinder (7) with two screws (8).
11. Fill master cylinder (3) 0.5 in. (12.7 mm) from top (LO 9-2320-209-12-1).
12. Connect line (4) on adapter (5).
13. Close and secure access door (1) on brace (2) with new screw-assembled lockwasher (6).

8-10. HYDRAULIC MASTER CYLINDER REPLACEMENT (Contd)

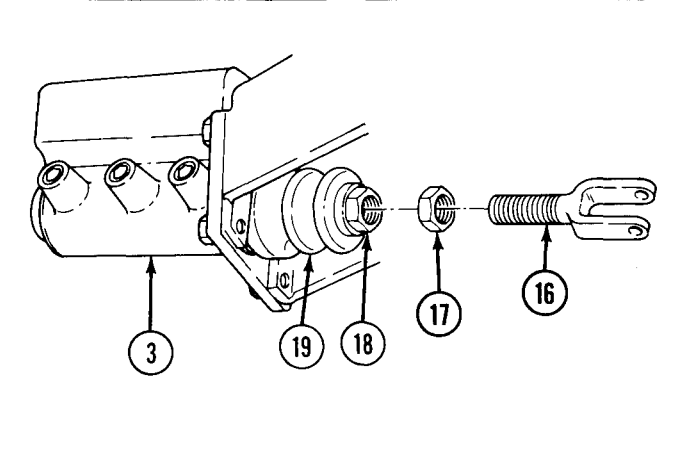
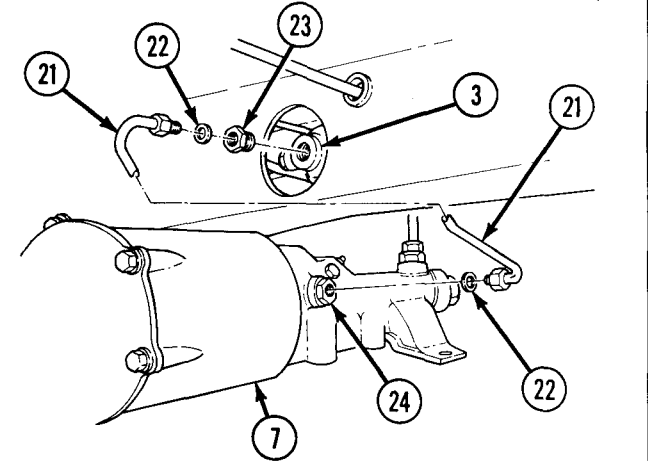
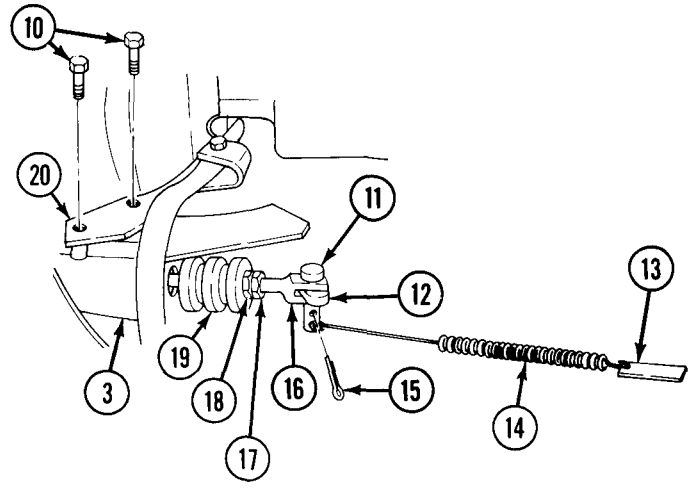
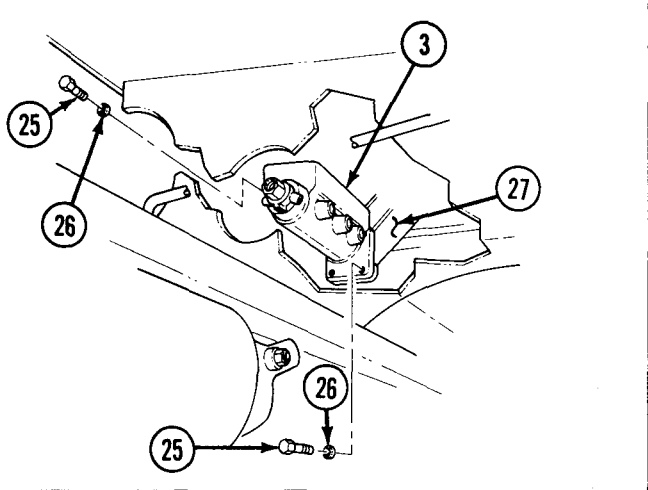
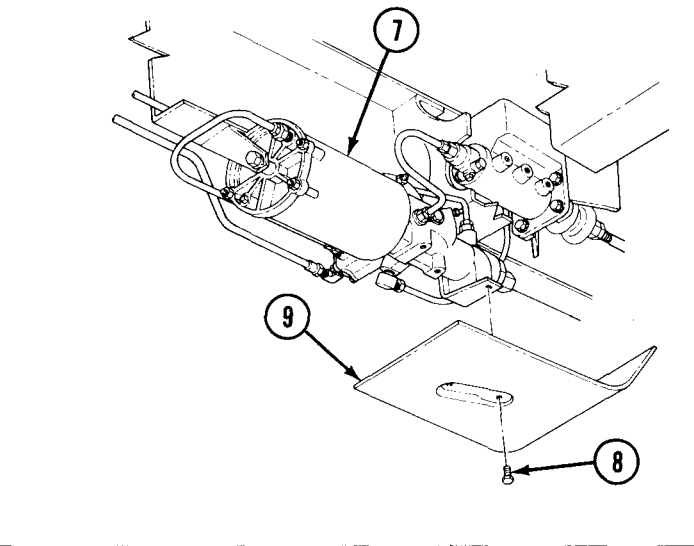
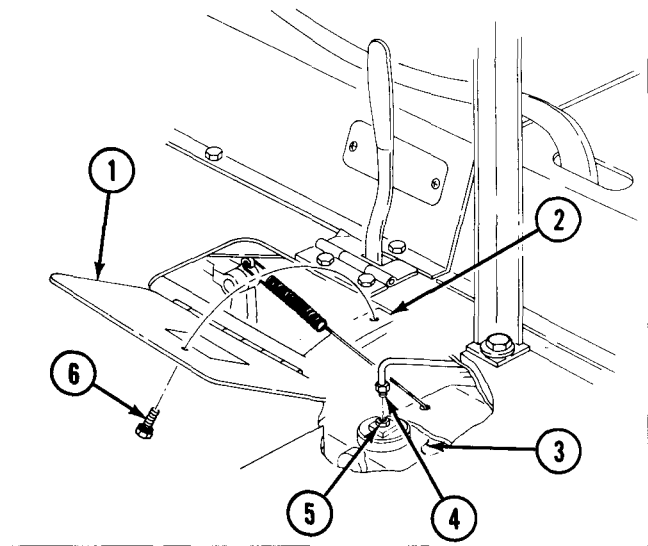

- FOLLOW-ON TASKS:
- Install transmission PTO shift linkage (M342A2) (para. 13-20).
  - Install hydraulic hoist control linkage (M342A2) (para. 13-22).
  - Install hydraulic hoist pump propeller shaft (M342A2) (para. 12-14).
  - Bleed service brake (para. 8-12).

## 8-11. AIR-HYDRAULIC CYLINDER REPLACEMENT

This task covers

**a. Removal**

**b. Installation**

INITIAL SETUP:

APPLICABLE MODELS

A 11

MATERIALS/PARTS

Two gaskets

Antiseize tape (Appendix C, Item 27)

Cap and plug set (Appendix C, Item 8)

REFERENCES (TM)

LO 9-2320-209-12-1

TM 9-2320-361-10

TM 9-2320-361-20P

EQUIPMENT CONDITION

- Parking brake set (TM 9-2320-361-10).
- Air system drained (TM 9-2320-361-10).

GENERAL SAFETY INSTRUCTIONS

Do not disconnect air lines before draining air reservoirs.

**WARNING**

Do not disconnect air lines before draining air reservoirs. Small parts under pressure may shoot out with high velocity, causing injury to personnel.

**CAUTION**

When disconnecting hydraulic lines and hoses, plug all openings to prevent dirt from entering and causing internal parts damage. Remove plugs prior to installation.

**NOTE**

Tag all air and hydraulic lines for installation.

**a. Removal**

**NOTE**

Have drainage container ready to catch brake fluid.

1. Remove two screws (10) and shield (11) from air-hydraulic cylinder (2).
2. Remove master cylinder hydraulic line (5) and gasket (3) from adapter (4). Discard gasket (3).
3. Loosen nut (6) and turn master cylinder hydraulic line (5) out of the way.
4. Disconnect hydraulic pressure line (7) from adapter (8).
5. Remove vent line (12) and gasket (13) from elbow (14). Discard gasket (13).
6. Disconnect trailer air line (21) from elbow (22).
7. Disconnect air supply line (16) from elbow (15).
8. Disconnect connector (20) from stoplight switch (19).
9. Remove screw (1) and air-hydraulic cylinder (2) from brackets (9) and (17).
10. Remove stoplight switch (19) from tee adapter (18).
11. Remove elbows (14), (15), and (22) and adapters (4) and (8) from air-hydraulic cylinder (2).
12. Remove, tag, clean, and inspect all adapters and elbows from air-hydraulic cylinder (2). Inspect for cracks, breaks, or stripped threads. If damaged, discard.

## 8-11. AIR-HYDRAULIC CYLINDER REPLACEMENT (Contd)

### b. Installation

#### NOTE

All male pipe threads must be wrapped with antiseize tape before installation.

1. Install elbows (14), (15), and (22) and adapters (4) and (8) on air-hydraulic cylinder (2).
2. Install stoplight switch (19) on tee adapter (18).
3. Install air-hydraulic cylinder (2) on brackets (17) and (9) with screw (1).
4. Connect connectors (20) to stoplight switch (19).
5. Connect air supply line (16) to elbow (15).
6. Connect trailer air line (21) to elbow (22).
7. Install new gasket (13) and connect vent line (12) to elbow (14).
8. Connect hydraulic pressure line (7) to adapter (8).
9. Install new gasket (3) and master cylinder hydraulic line (5) to adapter (4).
10. Tighten nut (6).
11. Install shield (11) on air-hydraulic cylinder (2) with two screws (10).

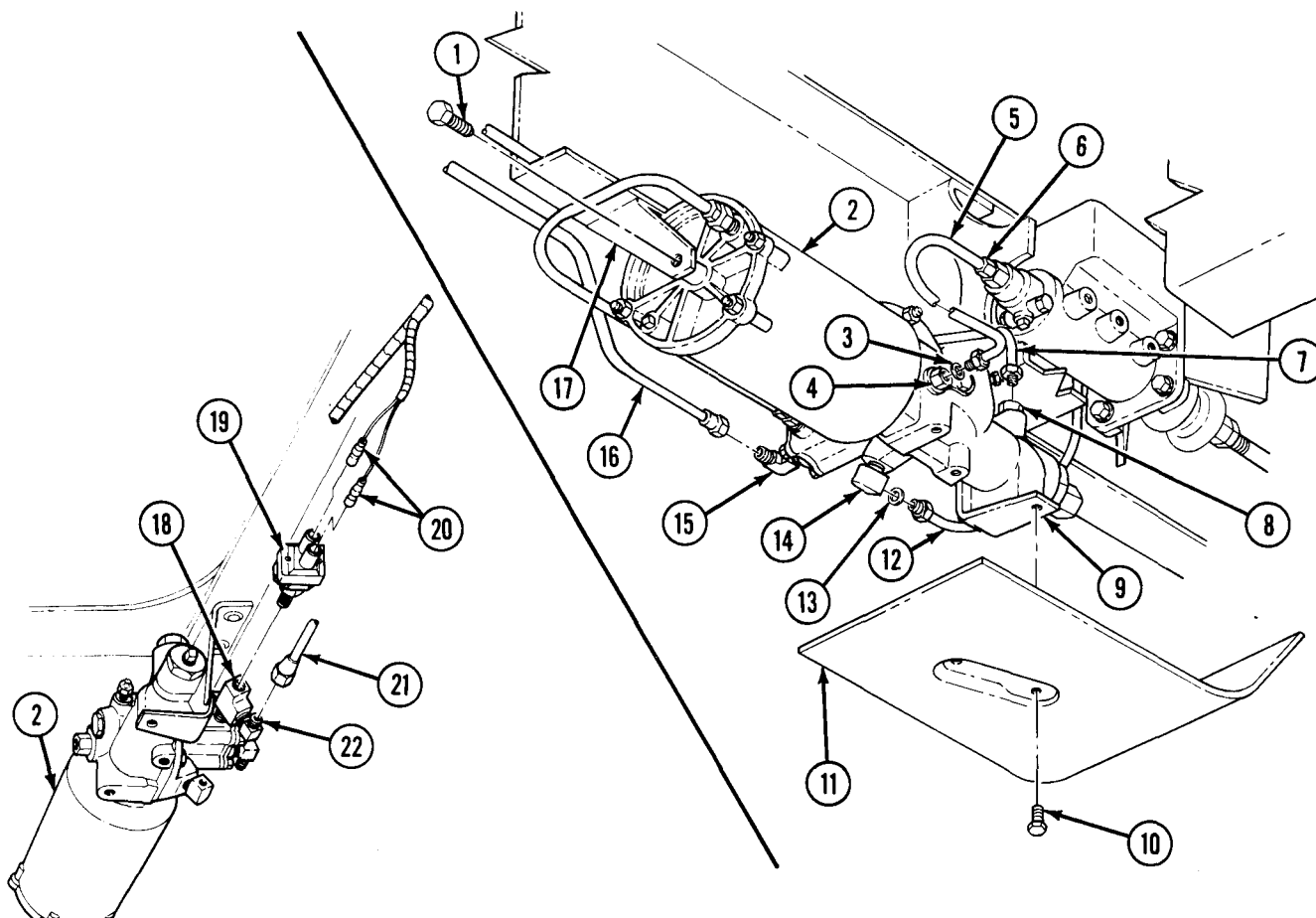

FOLLOW-ON TASKS: • Fill master cylinder (LO 9-2320-209-12-1).  
• Bleed service brakes (para. 8-12).

**8-12. SERVICE BRAKE BLEEDING**

This task covers:

**a. Pressure Tank Method**

**b. Manual Method**

INITIAL SETUP:

APPLICABLE MODELS

All

MATERIALS/PARTS

Hose

Screw-assembled lockwasher  
 Brake fluid (Appendix C, Item 7)  
 Rags (Appendix C, Item 21)

PERSONNEL REQUIRED

Two

REFERENCES (TM)

LO 9-2320-209-12-1  
 TM 9-2320-361-10  
 TM 9-2320-361-20P

EQUIPMENT CONDITION

Parking brake set (TM 9-2320-361-10).  
 Master cylinder filled (LO 9-2320-209-12-1).

**a. Pressure Tank Method**

1. Remove screw-assembled lockwasher (7) from brace (2) and open access door (1) exposing top of master cylinder (6). Discard screw-assembled lockwasher (7).
2. Disconnect vent line (3) from adapter (4).
3. Clean top of master cylinder (6) and remove filler plug (5).
4. Fill master cylinder (6) with fresh brake fluid to 1/2 in. (1.27 cm) from top.
5. Install adapter plug (9) and male quick-disconnect coupling (8) on master cylinder (6).
6. Make sure brake bleeder tank (10) is charged with brake fluid and is pressurized 20-25 psi (138-172 kPa). Follow manufacturers instructions for purging and preparation before connecting to brake system. Turn flow valve (13) "OFF" on tank hose (11), if so equipped.
7. Connect female quick-disconnect coupling (12) to male quick-disconnect coupling (8).
8. Turn flow valve (13) "ON", if so equipped.
9. Check for leaks and correct as necessary.

**CAUTION**

Always bleed air-hydraulic cylinder before bleeding downstream hydraulic components. Failure to do so may result in damage to equipment.

10. Clean around bleeder screw (19) located on top front of air-hydraulic cylinder (18).
11. Fill transparent container (17) 1/3 to 1/2 full of brake fluid.
12. Install flexible snug-fitting hose (16) on bleeder screw (19) and immerse other end of hose (15) in transparent container (17). Keep hose (16) end under surface of brake fluid at all times.
13. Loosen bleeder screw (19) 3/4 turn until brake fluid is flowing. Allow brake fluid to flow until no air bubbles are observed.

**NOTE**

If brake fluid doesn't flow after 3/4 turn, go to step 14; otherwise, go to step 15.

14. Turn valve (13) "OFF" and remove female quick-disconnect coupling (12). Remove and clean bleeder screw (14). Install bleeder screw (19) and repeat steps 7 through 13.
15. Close bleeder screw (19) and remove hose (16) from bleeder screw (19). Tighten bleeder screw (19) 10-20 lb-ft (14-27 N·m).
16. If hydraulic components of any one wheel were worked on, go to that wheel, clean around bleeder screw (19), and bleed brake system by performing steps 11 through 15. Install end of hose (16) on bleeder screw (15) and immerse other end of hose (16) in brake fluid in transparent container (17).

**8-12. SERVICE BRAKE BLEEDING (Contd)**

17. If all wheel cylinders (14) need to be bled, start with wheel cylinder farthest from air-hydraulic cylinder (18) and progressively go in distance sequence to wheel cylinder (18) nearest to air-hydraulic cylinder (18). Tighten wheel cylinder bleeder screws (15) 10-15 lb-ft (14-20 NŹm).
18. When finished bleeding hydraulic system, turn valve (13) "OFF" and disconnect female quick-disconnect coupling (12) on tank hose (11) from male quick-disconnect coupling (8) and adapter plug (9).

**CAUTION**

- Dispose of brake fluid in approved disposal area.
- Do not reuse brake fluid. Reusing brake fluid may result in damage to equipment.

19. Remove adapter plug (9) with male quick-disconnect coupling (8) and install filler plug (5) and adapter (4) in master cylinder (6). Tighten filler plug (5) 15-20 lb-ft (20-27 NŹm).
20. Connect vent line (3) to adapter (4).
21. Remove bleeder tank (10) from cab. Follow equipment manufacturers instructions for placing bleeder tank (10) in storage.
22. Close access door (1) and install new screw-assembled lockwasher (7).

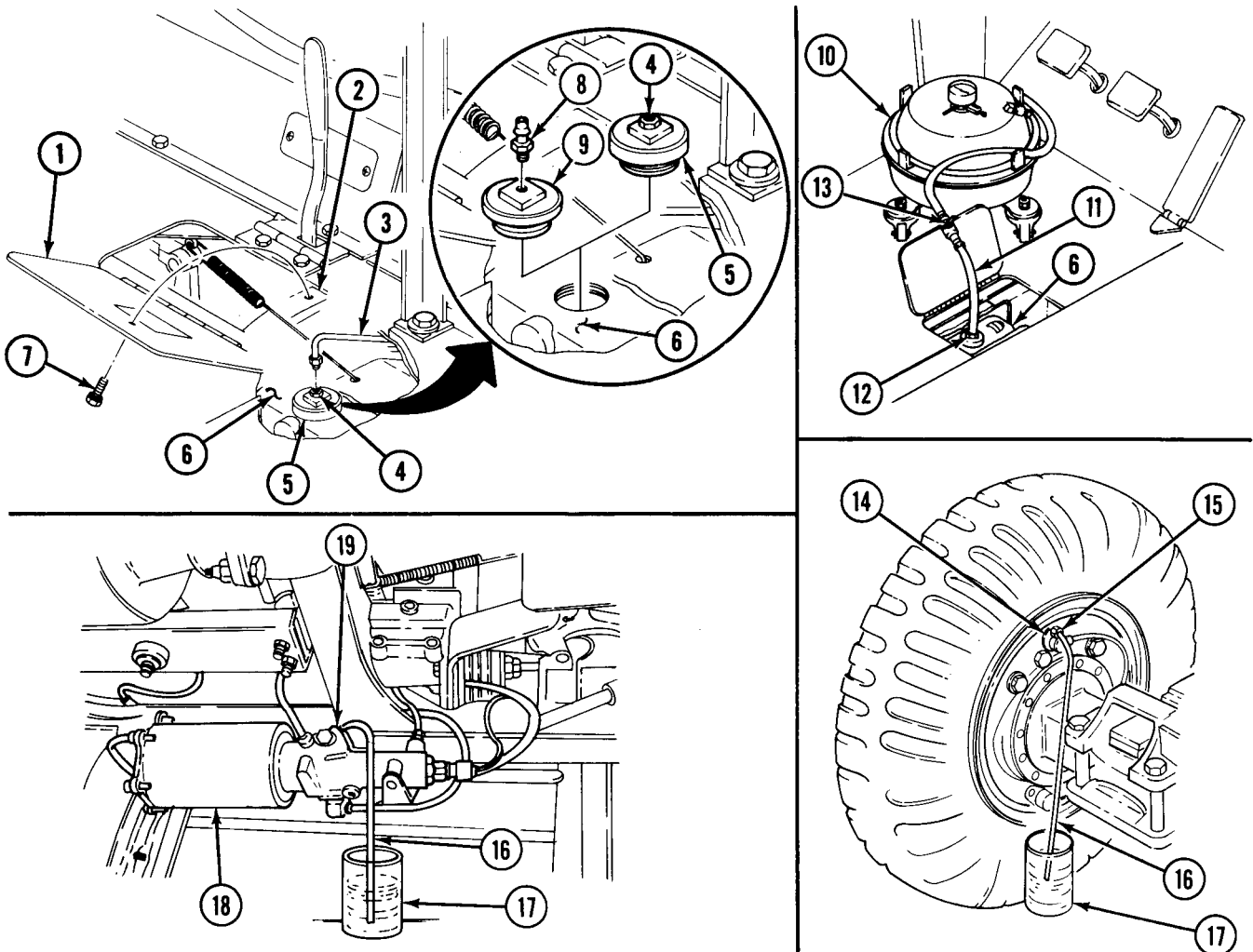

## 8-12. SERVICE BRAKE BLEEDING (Contd)

### b. Manual Method

1. Perform task a, steps 1 through 4.
2. Install filler plug (5).

#### **CAUTION**

Always bleed air-hydraulic cylinder before bleeding downstream hydraulic components. Failure to do so may result in damage to equipment.

3. Clean area around bleeder screw (8) on air-hydraulic cylinder (11).
4. Connect a snug fitting flexible hose (9) on bleeder screw (8) and immerse other end of hose (9) in a transparent container (10) 1/3 to 1/2 filled with brake fluid. Keep end of hose (9) always under surface of brake fluid.

#### **NOTE**

Assistant is required for steps 5 through 11.

5. Have assistant slowly apply and release brake pedal (12) twice, then slowly apply and hold down brake pedal (12). Have assistant tell you when holding down brake pedal (12).
6. While assistant holds brake pedal (12) down, open bleeder screw (8) 3/4 turn on air-hydraulic cylinder (11) or bleeder screw (14) on wheel cylinder (13). Observe for air bubbles in container (10) or (16).
7. Close bleeder screw (8) or (14) and inform assistant to release brake pedal (12). Refill master cylinder (6) with brake fluid.
8. Repeat steps 5 through 7 until no air bubbles appear when brake pedal (12) is applied.
9. Remove hose (9) from bleeder screw (8) and tighten bleeder screw (8) 10-20 lb-ft (14-27 Nǝm).

#### **NOTE**

- If wheel cylinders are to be bled, go to step 10. If not, go to step 14.
- If more than one wheel cylinder is to be bled, start with wheel cylinder farthest from master cylinder and progress in sequence to wheel cylinders closest to master cylinder.

10. Clean around bleeder screw (14) on wheel cylinder (13).
11. Connect a snug fitting flexible hose (15) to bleeder screw (14) and immerse end of hose (15) in a transparent container (16) 1/3 to 1/2 filled with brake fluid. Keep end of hose (15) always under surface of brake fluid.
12. Repeat steps 5,6,7, and 8.
13. When finished bleeding wheel cylinder (13), remove hose (15) and tighten bleeder screw (14) 10-15 lb-ft (14-20 Nǝm).

#### **CAUTION**

- Do not reuse brake fluid. Reusing brake fluid may result in damage to equipment.
- Dispose of brake fluid in approved disposal area.

14. Ensure master cylinder (6) is filled with fresh brake fluid to 0.5 in. (1.27 cm) from top.
15. Install filler plug (5) on master cylinder (6) and tighten to 15-20 lb-ft (21-28 Nǝm).
16. Connect line (3) to adapter (4).
17. Close access door (1) on brace (2) and install with screw-assembled lockwasher (7).

8-12. SERVICE BRAKE BLEEDING (Contd)

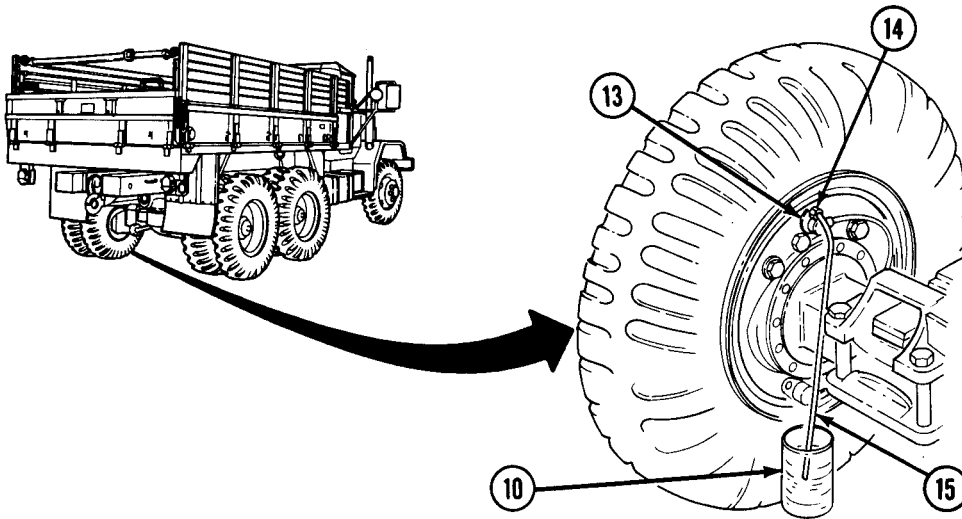
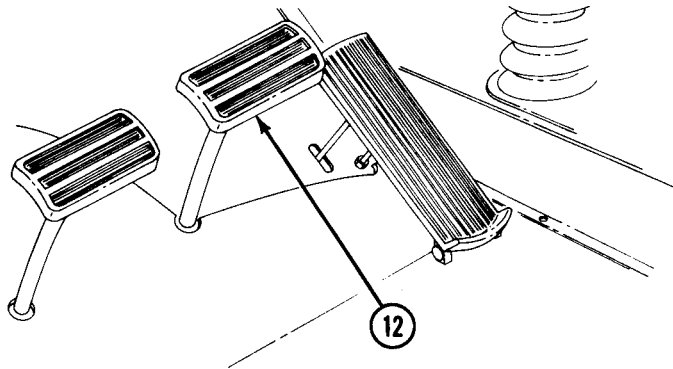
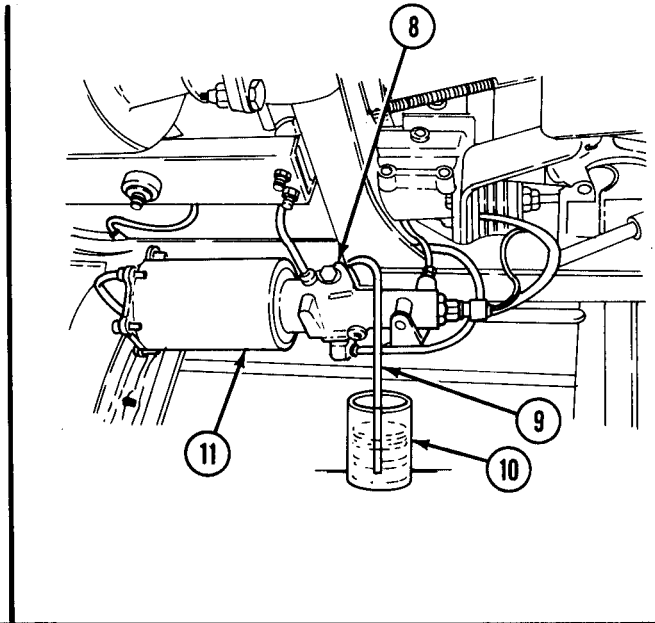
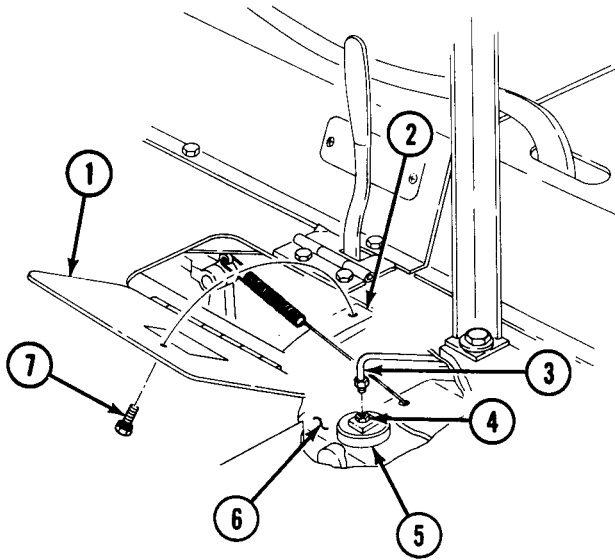



## 8-13. BRAKE PEDAL LEVER REPLACEMENT

This task covers:

### a. Removal

### b. Installation

INITIAL SETUP:

APPLICABLE MODELS

All

MATERIALS/PARTS

Cotter pin  
Two woodruff keys

PERSONNEL REQUIRED

Two

REFERENCES (TM)

TM 9-2320-361-10  
TM 9-2320-361-20P

EQUIPMENT CONDITION

- Parking brake set (TM 9-2320-361-10).
- Remove hydraulic hoist pump propeller shaft (M342A2) (para. 12-14).
- Remove transmission PTO shift linkage (if so equipped) (para. 13-20).  
Remove hydraulic hoist control linkage (M342A2) (para. 13-22).

### a. Removal

1. Unhook clutch return (1) from relay lever (2).
2. Unhook brake pedal return spring (14) from clevis pin (8).
3. Remove nut (19), washer (20), screw (3), and yoke rod (4) from relay lever (2).
4. Remove screw (5) and nut (21) from relay lever (2).
5. Remove relay lever (2) and woodruff key (18) from shaft (6). Discard woodruff key (18).
6. Remove screw (22), clutch pedal rod (24), and bumper (23) from arm (28).
7. Remove screw (27), clutch pedal arm (28), and woodruff key (26) from shaft (6). Discard woodruff key (26).
8. Remove screw (12), washer (11), brake pedal lever (13), and bumper (10) from brake pedal rod (9). Remove brake pedal rod (9) from cab.
9. Remove cotter pin (15), clevis pin (8), and yoke (16) from brake pedal lever (13). Discard cotter pin (15).

**NOTE**

- Assistant will help with steps 10 and 11.
  - On vehicles equipped with transmission power takeoff, pull shaft free of inside of bracket and brake pedal lever until lever can be removed.
10. Remove shaft (6) through bracket (17) and brake pedal lever (13) until brake pedal lever (13) can be removed from bracket (17).
  11. Remove shaft (6) from frame (25).
  12. Remove grease fitting (7) from brake pedal lever (13).

### b. Installation

**NOTE**

Assistant will help with step 1.  
When installing shaft make sure enough room is afforded for installation of relay lever and clutch pedal arm.

1. Position brake pedal lever (13) in bracket (17) and yoke (16), and install shaft (6) through frame (25), bracket (17), and brake pedal lever (13).

### 8-13. BRAKE PEDAL LEVER REPLACEMENT (Contd)

2. Install grease fitting (7) on brake pedal lever (13).
3. install clevis pin (8) through yoke (16) and brake pedal lever (13) with new cotter pin (15).
4. Install new woodruff key (18) and relay lever (2) on shaft (6) with screw (5) and nut (21).
5. Connect relay lever (2) to yoke rod (4) with screw (3), washer (20), and nut (19).
6. Install brake pedal rod (9) through cab floor and bumper (10) onto brake pedal lever (13) with washer (11) and screw (12).
7. Install new woodruff key (26) and clutch pedal arm (28) on shaft (6) with screw (27).
8. Install clutch pedal rod (24) through cab floor and bumper (23) and onto clutch pedal arm (28) with screw (22).
9. Connect brake pedal return spring (14) to clevis pin (8).
10. Connect clutch return spring (1) on relay lever (2).

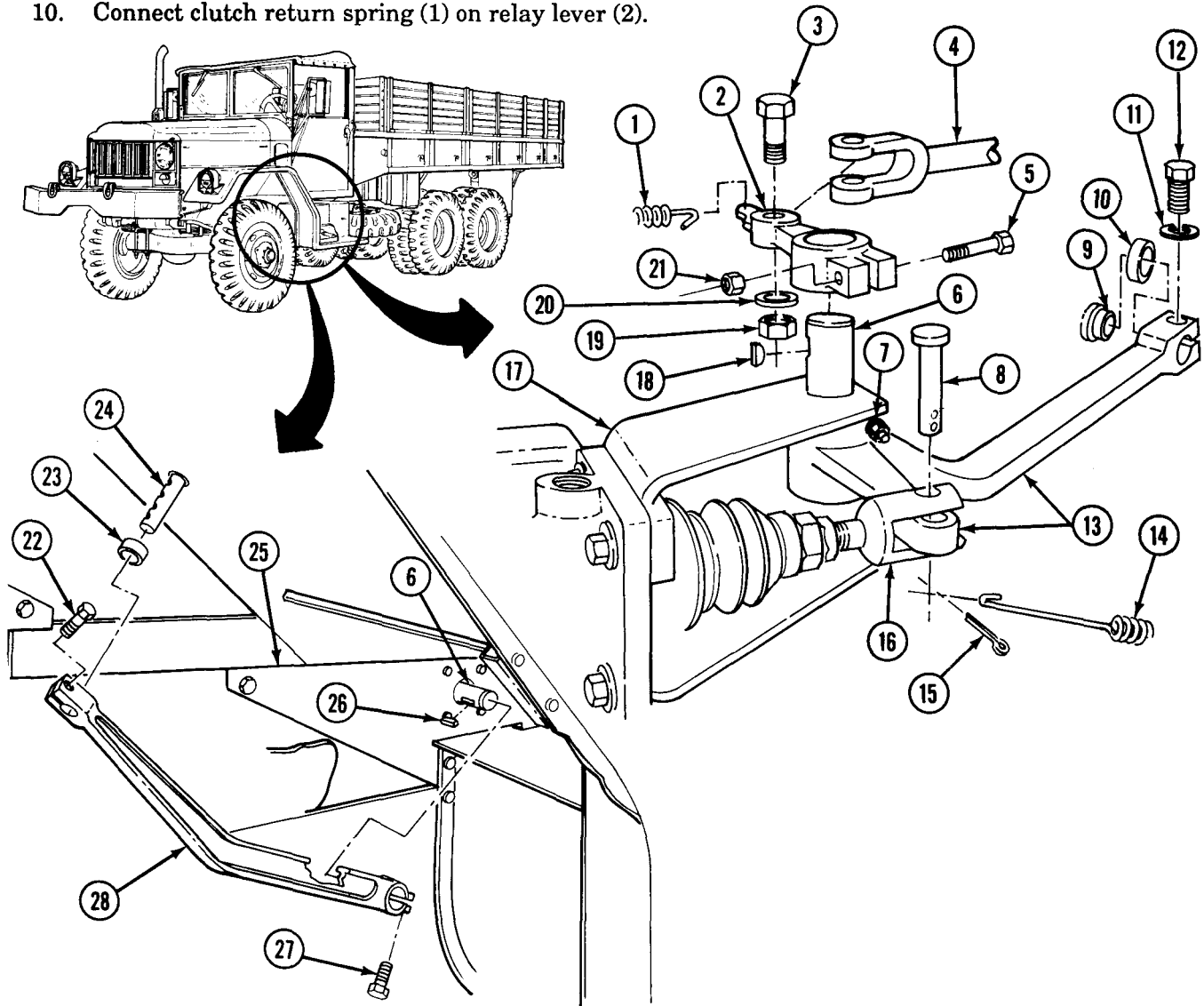

- FOLLOW-ON TASKS:**
- Install hydraulic hoist control linkage (M342A2) (para. 13-22).
  - Install transmission power takeoff shift linkage (if so equipped) (para. 13-20).
  - Install hydraulic hoist pump propeller shaft (M342A2) (para. 12-14).

## 8-14. BRAKE PEDAL ADJUSTMENT

This task covers:

### Adjustment

#### INITIAL SETUP:

##### APPLICABLE MODELS

All

##### MATERIALS/PARTS

Cotter pin  
Chalk (Appendix C, Item 9)

##### REFERENCES (TM)

TM 9-2320-361-10  
TM 9-2320-361-20P

##### EQUIPMENT CONDITION

Parking brake set (TM 9-2320-361-10).

### Adjustment

1. Mark brake pedal rod (2) with chalk, marking it even with cab floor (3).
2. Push brake pedal (1) down until freeplay is gone.
3. Mark brake pedal rod (2) with chalk, marking it even with cab floor (3), and then release brake pedal (1).
4. Measure distance between two marks (4). If distance is 0.25 -0.5 in. (6.35 -12.7 mm), adjustment is correct. If out of adjustment, proceed with steps 5 through 7.
5. Unhook spring (11) from clevis pin (8).
6. Remove cotter pin (10), clevis pin (8), and yoke (7) from brake pedal lever (9). Discard cotter pin (10).
7. Loosen jamnut (5) and adjust pushrod (6) until proper adjustment is obtained.
8. Install yoke (7) on brake pedal lever (9) with clevis pin (8).
9. Hook spring (11) to clevis pin (8).
10. Repeat steps 1 through 9 until freeplay is correct as indicated in step 4.
11. Install new cotter pin (10) through clevis pin (8).
12. Tighten jamnut (5) against pushrod (6).

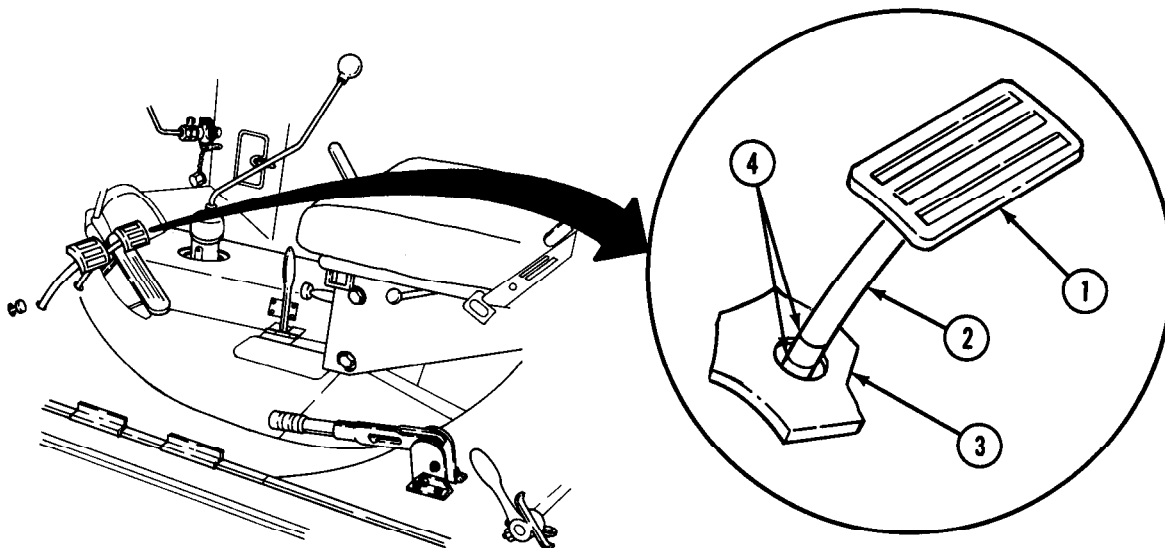

8-14. BRAKE PEDAL ADJUSTMENT Contd)

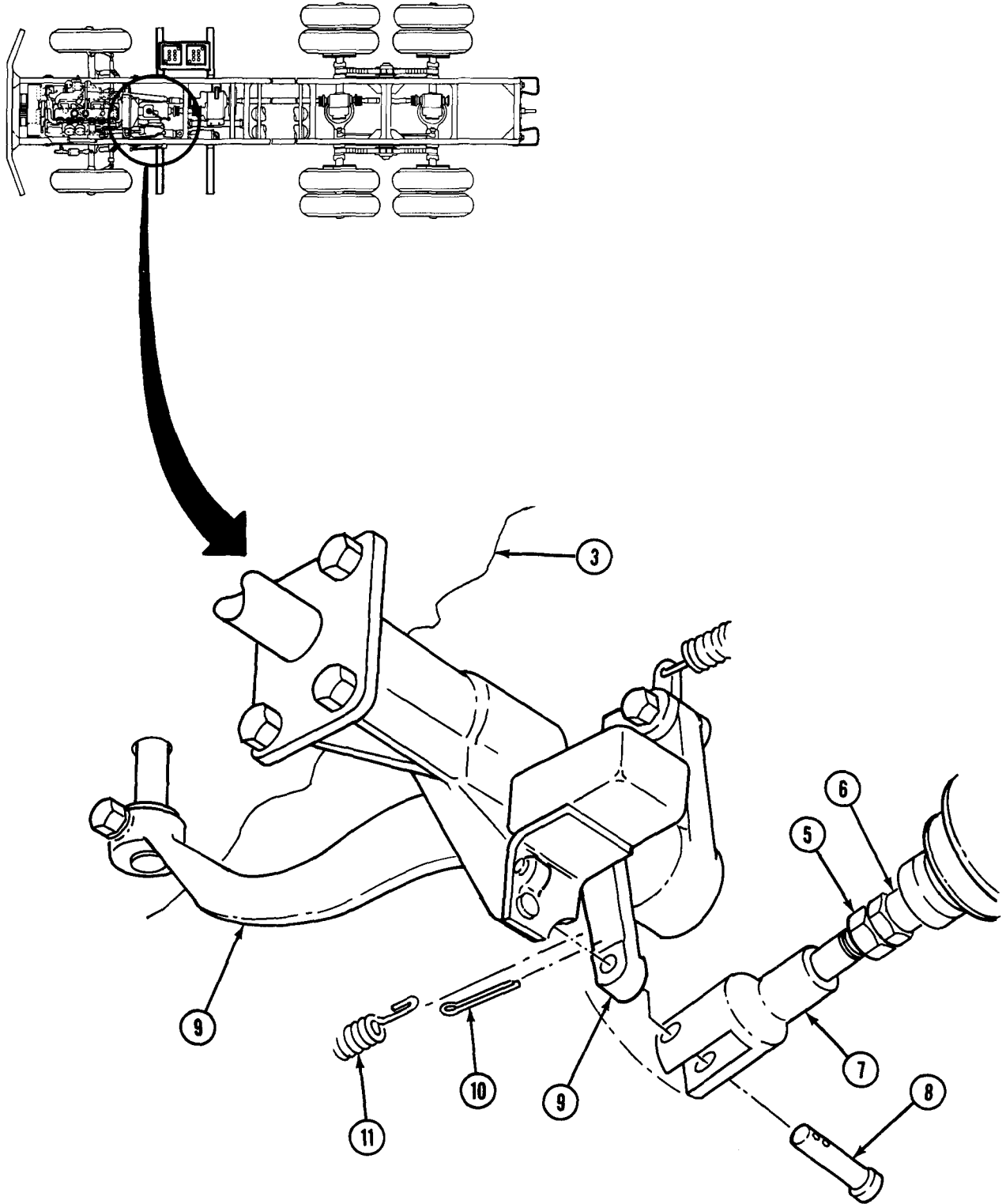

## 8-15. HYDRAULIC BRAKE LINE REPLACEMENT

This task covers

### INITIAL SETUP:

APPLICABLE MODELS

All

MATERIALS/PARTS

Lockwasher

Locknut

Two screw-assembled lockwashers

Cap and plug set (Appendix C, Item 8)

REFERENCES (TM)

LO 9-2320-209-12-1

TM 9-2320-361-10

TM 9-2320-361-20P

EQUIPMENT CONDITION

Parking brake set (TM 9-2320-361-10).

GENERAL SAFETY INSTRUCTIONS

New, longer hydraulic brake line must be installed.

### WARNING

Short front flexible hydraulic brake lines are subject to failure during full steering travel and must be replaced with new, longer flexible hydraulic brake lines P/N 7409330. Failure to do this may cause injury or death to personnel. Refer to para. 8-16 for replacement.

### CAUTION

Cap or plug all openings immediately after disconnecting lines and hoses to prevent contamination. Failure to do so may result in internal parts damage.

### NOTE

All hydraulic brake and compressed air lines are replaced the same. This procedure covers the front flexible hydraulic brake line.

#### a. Removal

1. Disconnect spring (7) from spring plate (5).
2. Remove nut (3), lockwasher (4), and spring plate (5) from steering arm (2). Discard lockwasher (4).
3. Remove locknut (14), screw (6), spring (7), and clamp (8) from flexible hydraulic brake line (15). Discard locknut (14).

### NOTE

Have container ready to catch hydraulic fluid.

4. Disconnect flexible hydraulic brake line (15) from inlet connector (1).
5. Remove brake line (13) from flexible hydraulic brake line (15).
6. Remove nut (12) and flexible hydraulic brake line (15) from bracket (10).
7. Remove two screw-assembled lockwashers (9) and bracket (10) from axle housing (11) and brake line (13). Discard screw-assembled lockwashers (9).

#### b. Installation

1. Install bracket (10) on axle housing (11) with two new screw-assembled lockwashers (9).
2. Connect flexible hydraulic brake line (15) to inlet connector (1).
3. Install flexible hydraulic brake line (15) on bracket (10) with nut (12).
4. Install brake line (13) on flexible hydraulic brake line (15).
5. Install clamp (8) on flexible hydraulic brake line (15) with spring (7), screw (6), and new locknut (14).

## 8-15. HYDRAULIC BRAKE LINE REPLACEMENT (Contd)

5. Install spring plate (5) on steering arm (2) with new lockwasher (4) and nut (3). Tighten nut (3) to 130-167 lb-ft (176-227 N·m).
6. Connect spring (7) on spring plate (5).

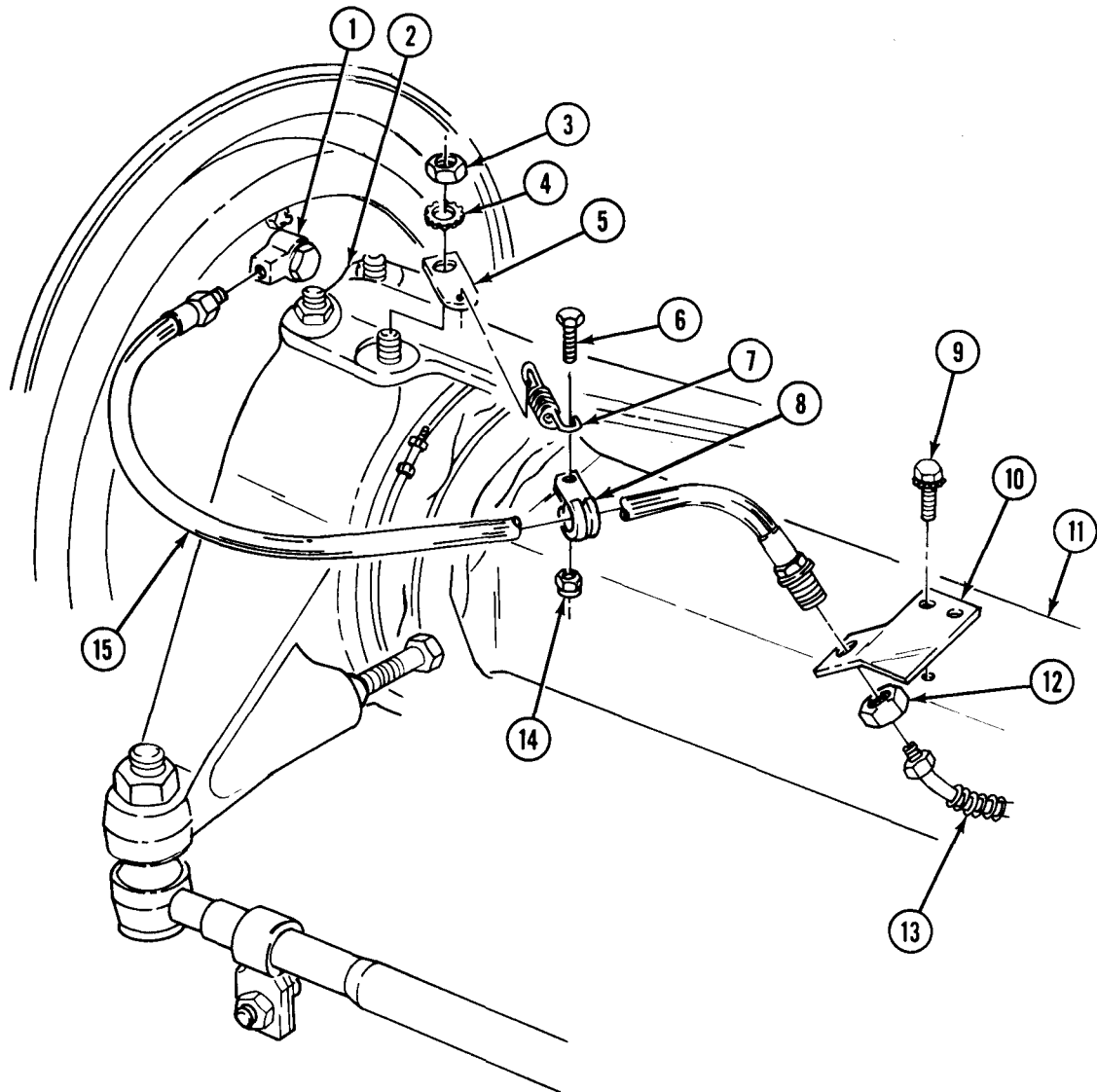

- FOLLOW-ON TASKS:
- Fill master cylinder (LO 9-2320-209-12-1).
  - Bleed service brakes (para. 8-12).

**8-16. FLEXIBLE HYDRAULIC BRAKE LINE MODIFICATION**

This task covers:

- a. Removal
- b. Modification

- c. Installation

**INITIAL SETUP:**

APPLICABLE MODELS

All

MATERIALS/PARTS

- Three lockwashers
- Two screw-assembled lockwashers
- Locknut
- Screw
- Spring plate
- Spring
- Clamp
- Brake line P/N 7409330
- Cap and plug set (Appendix C, Item 8)

REFERENCES (TM)

- LO 9-2320-209-12-1
- TM 9-2320-361-10
- TM 9-2320-361-20P

EQUIPMENT CONDITION

Parking brake set (TM 9-2320-361-10).

GENERAL SAFETY INSTRUCTIONS

New, longer hydraulic brake line must be installed.

**WARNING**

Ensure new, longer front hydraulic brake lines, currently used on 5-ton trucks, are installed on all 2-1/2-ton trucks. Old, shorter front hydraulic brake lines are subject to failure during full steering travel and must be replaced with new, longer front brake hoses. Failure to do this will result in injury or death to personnel.

**CAUTION**

Cap or plug all openings immediately after disconnecting lines and hoses to prevent contamination. Failure to do so may result in internal parts damage.

**NOTE**

Left and right front flexible hydraulic lines are replaced the same. This procedure covers the left front.

**a. Removal**

1. Remove two nuts (2), lockwashers (1), and steering guard (4) from steering arm (7). Discard lockwashers (1).
2. Remove locknut (6), screw (3), and bracket (5) from steering guard (4). Discard screw (3) and locknut (6).

**NOTE**

Have container ready to catch hydraulic fluid.

3. Disconnect steel brake line (15) from inlet connector (14).
4. Disconnect brake line (12) from flexible hydraulic brake line (13).
5. Remove nut (11), old flexible hydraulic brake line (13) with steel brake line (15), and bracket (5) from bracket (10). Discard nut (11), old flexible hydraulic brake line (13) with steel brake line (15), and bracket (5).
6. Remove two screw-assembled lockwashers (9) and bracket (10) from axle housing (8). Discard screw-assembled lockwashers (9).

**8-16. FLEXIBLE HYDRAULIC BRAKE LINE MODIFICATION (Contd)**

**b. Modification**

1. Bend bracket (10) tab to a 45° angle. Check bracket (10) for cracks. If cracked, replace bracket (10) and repeat step.
2. Locate and drill 0.46 in. (10.3 mm) hole (17), 0.5 in. (12.7 mm) from bracket corners (16).

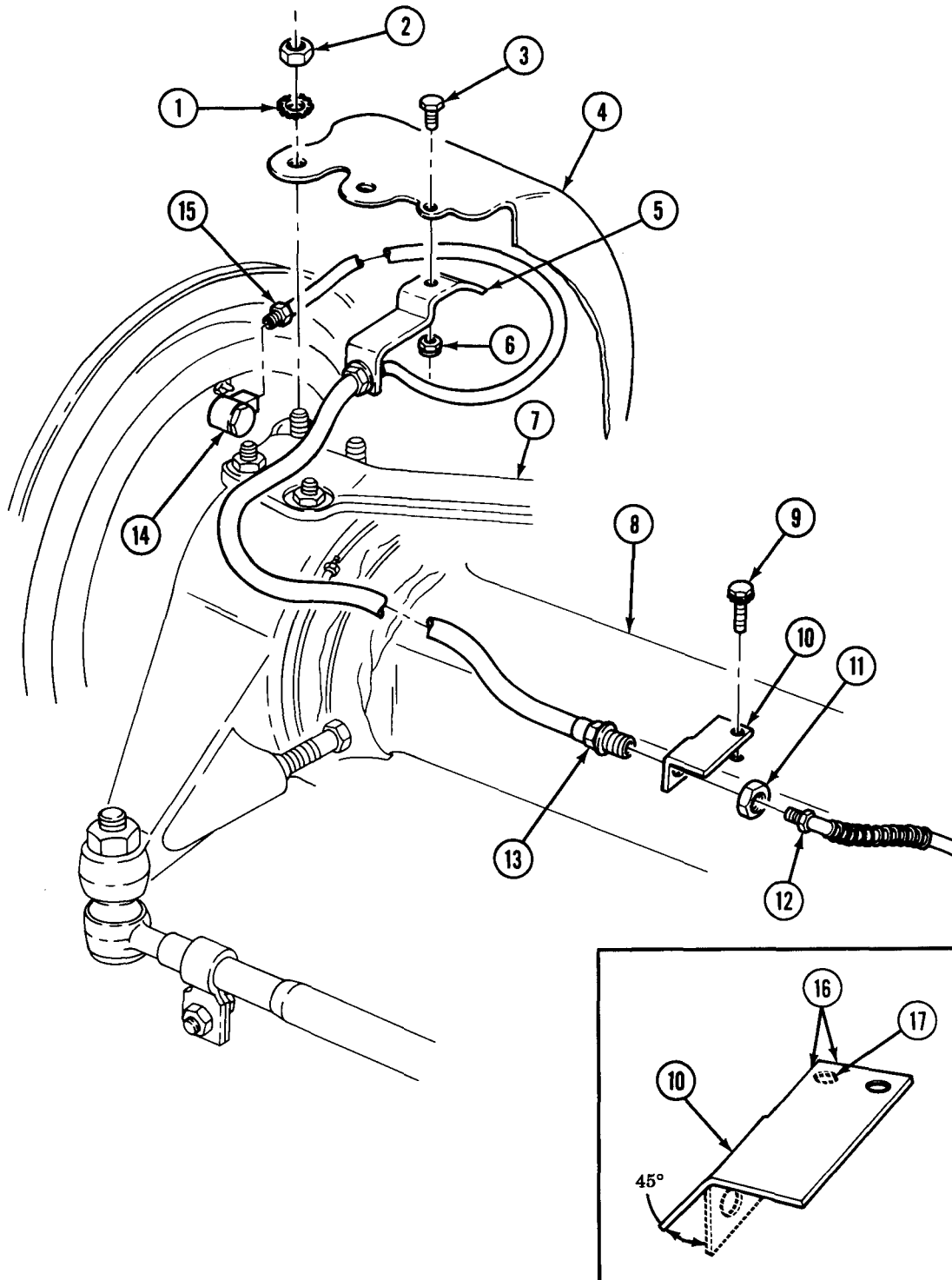



**8-16. FLEXIBLE HYDRAULIC BRAKE LINE MODIFICATION (Contd)**

**c. Installation**

1. Loosen brake cylinder inlet conector (17) and rotate 180° (1/2 turn) so that inlet connector (17) is toward rear of vehicle. Tighten brake cylinder inlet conector (17).
2. Install new, altered bracket (10) on axle housing (11) with two new screw-assembled lock-washers (9).
3. Install new, longer flexible hydraulic brake line (16) to inlet connector (17), and other end to new, altered bracket (10) with new nut (13).
4. Install brake line (12) to brake line (16).
5. Install new spring plate (6) on steering arm (18) with new lockwasher (5) and nut (4). Tighten nut (4) to 130-167 lb-ft (176-227 NŹm).
6. Install new clamp (15) and spring (8) on new, long flexible hydraulic brake line (16) with screw (7) and new locknut (14).
7. Connect new spring (8) on spring plate (6).
8. Install steering guard (1) on steering arm (18) with two new lockwashers (3) and nuts (2). Tighten nuts (2) 130-167 lb-ft (176-227 NŹm).

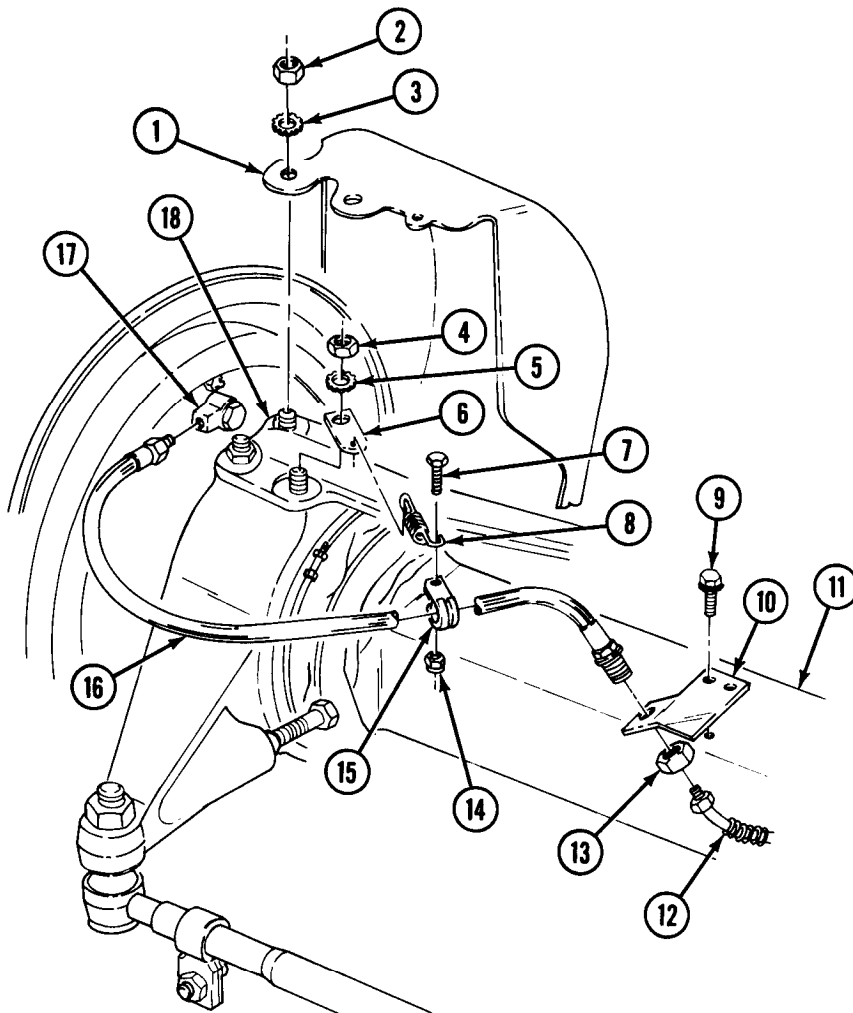

FOLLOW-ON TASKS: •Fill master cylinder (LO 9-2320-209-12-1).  
 •Bleed service brakes (para. 8-12).

## Section III. COMPRESSED AIR SYSTEM MAINTENANCE

**8-17. GENERAL**

- a. For fabrication instructions of air lines, refer to TM 9-243.
- b. For schematic representation of air line locations and routing, see appendix F of this manual.

**8-18. COMPRESSED AIR SYSTEM MAINTENANCE INDEX**

PARA. NO.	TITLE	PAGE NO.
8-19.	Windshield Wiper Motor Control Valve Replacement	8-46
8-20.	Air System Safety Valve Replacement	8-47
8-21.	Airbrake Hand Control Valve Replacement	8-48
8-22.	Airbrake Valve Replacement	8-50
8-23.	Air Reservoirs Replacement (M275A2, M342A2)	8-52
8-24.	Air Reservoirs Replacement	8-54
8-25.	Air Reservoirs Replacement (M764)	8-60
8-26.	Air Compressor and Pulley Replacement	8-62
8-27.	Air Compressor Servicing	8-66
8-28.	Air Compressor Drivebelt Replacement	8-68
8-29.	Air Compressor Governor Maintenance	8-70
8-30.	Quick-Disconnect Coupling Half Maintenance	8-74
8-31.	Airbrake Cutoff Valves and Couplings Replacement	8-76
8-32.	Airbrake Cutoff Valves and Couplings Replacement (M764)	8-78
8-33.	Airbrake Cutoff Valves and Couplings Replacement (M275A2, M342A2)	8-80
8-34.	Airbrake Hose Replacement	8-82
8-35.	Shuttle (Double Check) Valve Replacement	8-84
8-36.	Trailer Protection Valve Replacement	8-86
8-37.	Trailer Brake Hose Mast Replacement	8-88

**8-19. WINDSHIELD WIPER MOTOR CONTROL VALVE REPLACEMENT**

This task covers:

**a. Removal**

**b. Installation**

**INITIAL SETUP:**

APPLICABLE MODELS

All

MATERIALS/PARTS

Antiseize tape (Appendix C, Item 27)

REFERENCES (TM)

TM 9-2320-361-10

TM 9-2320-361-20P

EQUIPMENT CONDITION

- Parking brake set (TM 9-2320-361-10).
- Air reservoirs drained (TM 9-2320-361-10).

GENERAL SAFETY INSTRUCTIONS

Do not disconnect air lines before draining air reservoirs.

**WARNING**

Do not disconnect air lines before draining air reservoirs. Small parts under pressure may shoot out with high velocity causing injury to personnel.

**NOTE**

Tag all air lines and hoses for installation.

1. Remove air line (1) from adapter (2) and air line (9) from adapter (8).
2. Loosen two setscrews (6) and remove knob (7) from wiper motor control valve (3).
3. Remove jamnut (5) and wiper motor control valve (3) from instrument panel (4).
4. Remove adapters (2) and (8) from wiper motor control valve (3) and inspect for cracks, bends, or breaks. If damaged, replace.

**b. Installation**

**NOTE**

All male pipe threads must be wrapped with antiseize before installation.

1. Install adapters (8) and (2) on wiper motor control valve (3).
2. Install wiper motor control valve (3) on instrument panel (4) with jamnut (5).
3. Install knob (7) on wiper motor control valve (3) and tighten two setscrews (6).
4. Install air line (9) on adapter (8) and air line (1) on adapter (2).

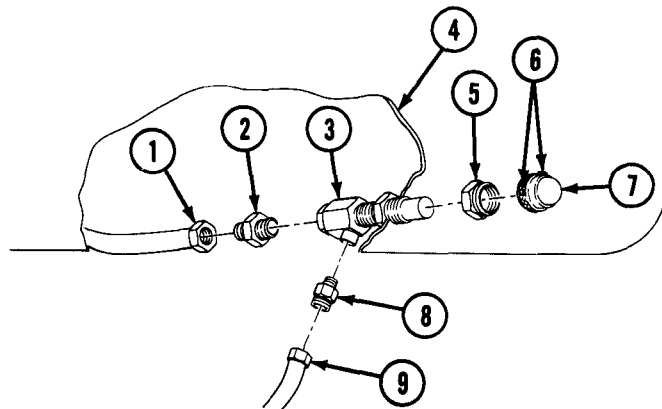

**FOLLOW-ON TASK:** Start engine (TM 9-2320-361-10), build up air pressure, and check operation of windshield wiper motor.

**8-20. AIR SYSTEM SAFETY VALVE REPLACEMENT**

This task covers:

**a. Removal**

**b. Installation**

INITIAL SETUP:

APPLICABLE MODELS

All

MATERIALS/PARTS

Antiseize tape (Appendix C, Item 27)

REFERENCES (TM)

TM 9-2320-361-10

TM 9-2320-361-20P

EQUIPMENT CONDITION

- Parking brake set (TM 9-2320-361-10).
- Air reservoirs drained (TM 9-2320-361-10).

GENERAL SAFETY INSTRUCTIONS

Do not disconnect air lines before draining air reservoirs.

**a. Removal**

**WARNING**

Do not disconnect air lines before draining air reservoirs. Small parts under pressure may shoot out with high velocity, causing injury to personnel.

Remove air system safety valve (1) from tee fitting (2).

**b. Installation**

**NOTE**

All male pipe threads must be wrapped with antiseize tape before installation.

Install air system safety valve (1) in tee fitting (2).

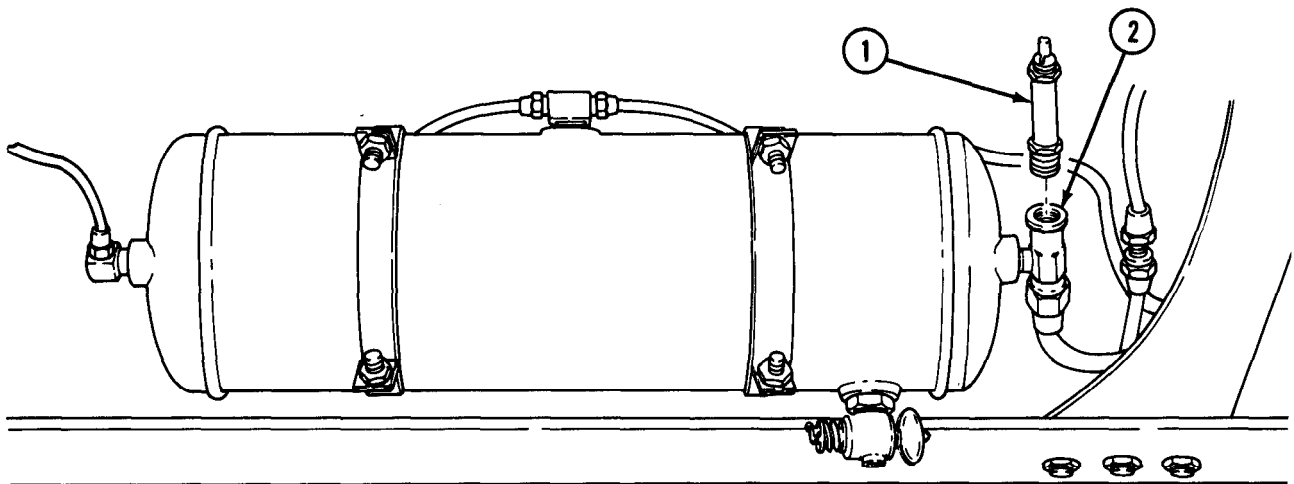

FOLLOW-ON TASK: Start engine (TM 9-2320-361-10), build up air pressure, and check for leaks.

**8-21. AIRBRAKE HAND CONTROL VALVE REPLACEMENT**

This task covers:

**a. Removal**

**b. Installation**

**INITIAL SETUP:**

APPLICABLE MODELS

All

MATERIALS/PARTS

Two lockwashers  
Antiseize tape (Appendix C, Item 27)

REFERENCES (TM)

TM 9-2320-361-10  
TM 9-2320-361-20P

EQUIPMENT CONDITION

- Parking brake set (TM 9-2320-361-10).
- Air reservoirs drained (TM 9-2320-361-10).

GENERAL SAFETY INSTRUCTIONS

Do not disconnect air lines before draining air reservoirs.

**a. Removal**

**WARNING**

Do not disconnect air lines before draining air reservoirs. Small parts under pressure may shoot out with high velocity, causing injury to personnel.

**NOTE**

Tag all air lines for installation.

1. Remove valve outlet air line (8) from adapter (9).
2. Remove two air supply lines (7) from two adapters (6).
3. Remove two screws (2), lockwashers (3), clamp (4), and hand control valve (1) from steering column (5). Discard lockwashers (3).
4. Remove two adapters (6) and adapter (9) from hand control valve (1) and inspect for stripped threads, cracks, or breaks. If cracked, broken, or threads are stripped, replace adapters (6) and (9) and hand control valve (1).

**b. Installation**

**NOTE**

All male pipe threads must be wrapped with antiseize tape before installation.

1. Install two adapters (6) and adapter (9) on hand control valve (1).
2. Install hand control valve (1) on steering column (5) with clamp (4), two new lockwashers (3), and screws (2).
3. Install two air supply lines (7) on two adapters (6).
4. Install outlet air line (8) on adapter (9).

8-21. AIRBRAKE HAND CONTROL VALVE REPLACEMENT (Contd)

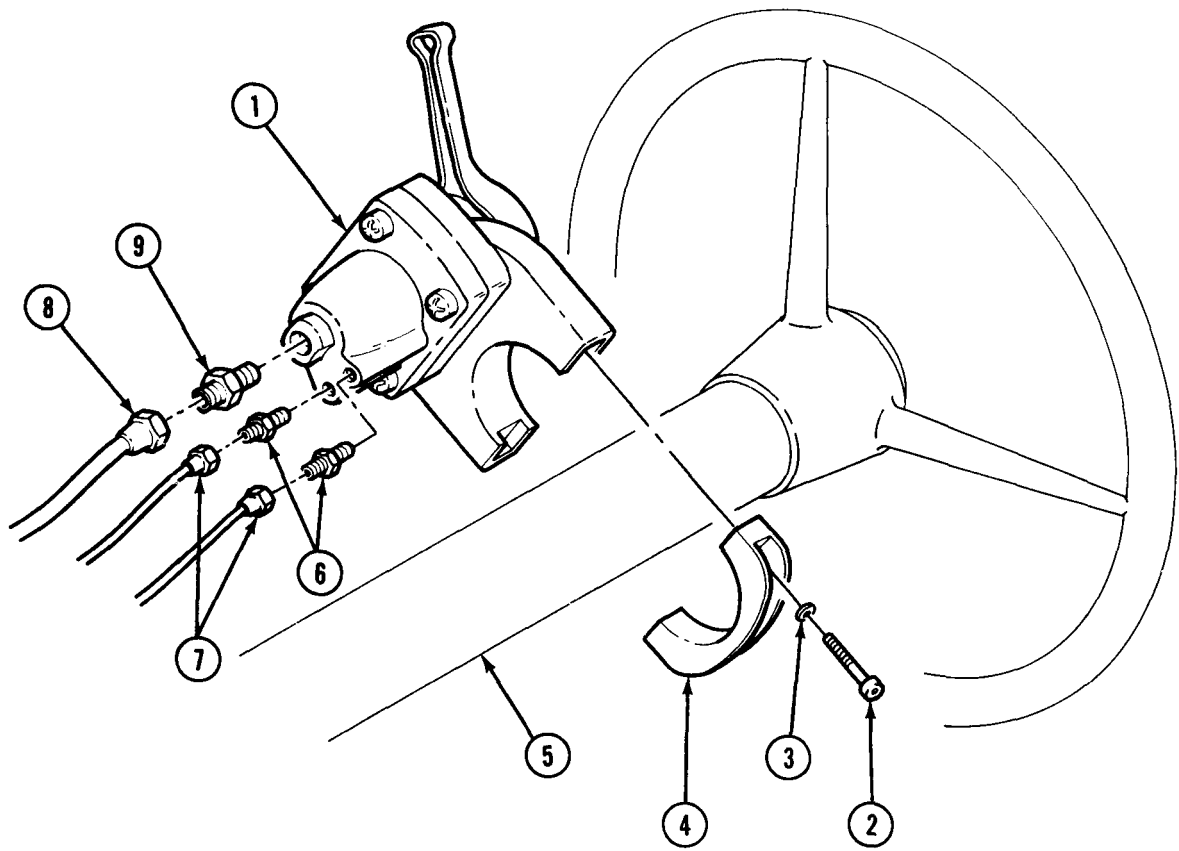

FOLLOW-ON TASK : Start engine (TM 9-2320-361-10), build up air pressure, and check operation of airbrake hand control valve.

## 8-22. AIRBRAKE VALVE REPLACEMENT

This task covers:

### a. Removal

### b. Installation

#### INITIAL SETUP:

##### APPLICABLE MODELS

M275A2

##### MATERIALS/PARTS

Two drivescrews  
Antiseize tape (Appendix C, Item 27)

##### REFERENCES (TM)

TM 9-2320-361-10  
TM 9-2320-361-20P

##### EQUIPMENT CONDITION

- Parking brake set (TM 9-2320-361-10).
- Air reservoirs drained (TM 9-2320-361-10).

##### GENERAL SAFETY INSTRUCTIONS

Do not disconnect air lines before draining air reservoirs.

### a. Removal

#### WARNING

Do not disconnect air lines before draining air reservoirs. Small parts under pressure may shoot out with high velocity, causing injury to personnel.

#### NOTE

The left and right side valves are replaced the same. This procedure covers the left side.

1. Remove air hose (1) from adapter (8).
2. Remove adapter (8) from airbrake valve (2) and inspect adapter (8) for stripped threads, cracks, or breaks. If damaged, replace.
3. Remove air line (5) from adapter (6).
4. Remove adapter (6) and airbrake valve (2) from bracket (4) and plate (3). Inspect adapter (6) for stripped threads, cracks, or breaks. If damaged, replace.

#### NOTE

Perform step 5 only if plate requires replacement.

5. Remove two drivescrews (7) and plate (3) from bracket (4). Discard drivescrews (7).

### b. Installation

#### NOTE

Perform step 1 only if plate was removed.

1. Install plate (3) on bracket (4) with two new drivescrews (7).

#### NOTE

All male pipe threads must be wrapped with antiseize tape before installation.

2. Install airbrake valve (2) on bracket (4) with adapter (6).
3. Install air line (5) on adapter (6).
4. Install adapter (8) on airbrake valve (2).
5. Install air hose (1) on adapter (8).

8-22. AIRBRAKE VALVE REPLACEMENT (Contd)

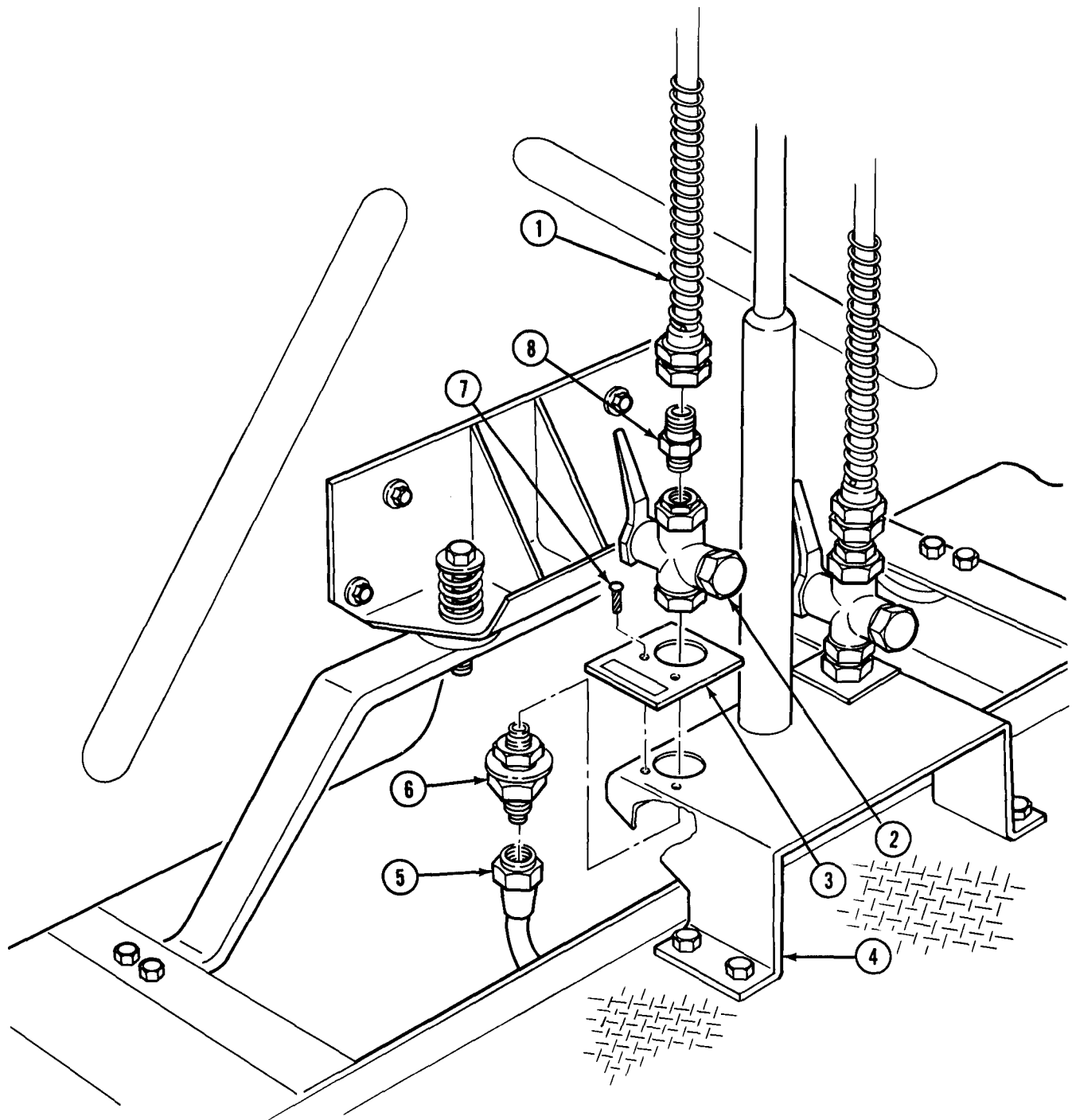

FOLLOW-ON TASK: Start engine (TM 9-2320-361-10), build up air pressure, and check for leaks.



**8-23. AIR RESERVOIRS REPLACEMENT (M275A2, M342A2)**

This task covers:

**a. Removal**

**b. Installation**

**INITIAL SETUP:**

APPLICABLE MODELS

M275A2, M342A2

MATERIALS/PARTS

Eight locknuts  
Antiseize tape (Appendix C, Item 27)

REFERENCES (TM)

TM 9-2320-361-10  
TM 9-2320-361-20P

EQUIPMENT CONDITION

- Parking brake set (TM 9-2320-361-10).
- Air system safety valve removed (para. 8-20).
- Right-rear splash shield removed (M275A2) (para. 12-103).

**a. Removal**

**NOTE**

Tag air lines for installation.

1. Remove two air lines (3) and (5) from tee fitting (4).
2. Remove air line (12) from elbow (14) and adapter (11).
3. Remove two air lines (21) and (2) from elbow (20) and tee fitting (1).
4. Remove four locknuts (17) and two U-bolts (19) from lower air reservoir (18) and two brackets (16). Discard locknuts (17).
5. Remove lower air reservoir (18) from two brackets (16).
6. Remove four locknuts (9) and two U-bolts (8) from upper air reservoir (7) and two brackets (16). Discard locknuts (9).
7. Remove upper air reservoir (7) from brackets (16).

**NOTE**

Record both location and position of all fittings for installation.

8. Remove two elbows (14) and (20), tee fitting (4), and draincock (15) from lower air reservoir (18).
9. Remove tee fitting (1), plug (6), adapter (11), elbow (10), and draincock (13) from upper air reservoir (7).

**b. Installation**

**NOTE**

- All fittings must be cleaned and inspected before installation.
- All male pipe threads must be wrapped with antiseize tape before installation.

1. Install two elbows (14) and (20), tee fitting (4), and draincock (15) on lower air reservoir (18).
2. Install tee fitting (1), plug (6), elbow (10), and draincock (13) on upper air reservoir (7).
3. Install adapter (11) in elbow (10).
4. Install upper air reservoir (7) on two brackets (16) with two U-bolts (8) and four new locknuts (9).
5. Install lower air reservoir (18) on two brackets (16) with two U-bolts (19) and four new locknuts (17).
6. Install two air lines (23) and (21) on tee fitting (1) and elbow (20).
7. Install two air lines (5) and (3) on tee fitting (4).
8. Install air line (12) on elbow (14) and adapter (11).

8-23. AIR RESERVOIRS REPLACEMENT (M275A2, M342A2) (Contd)

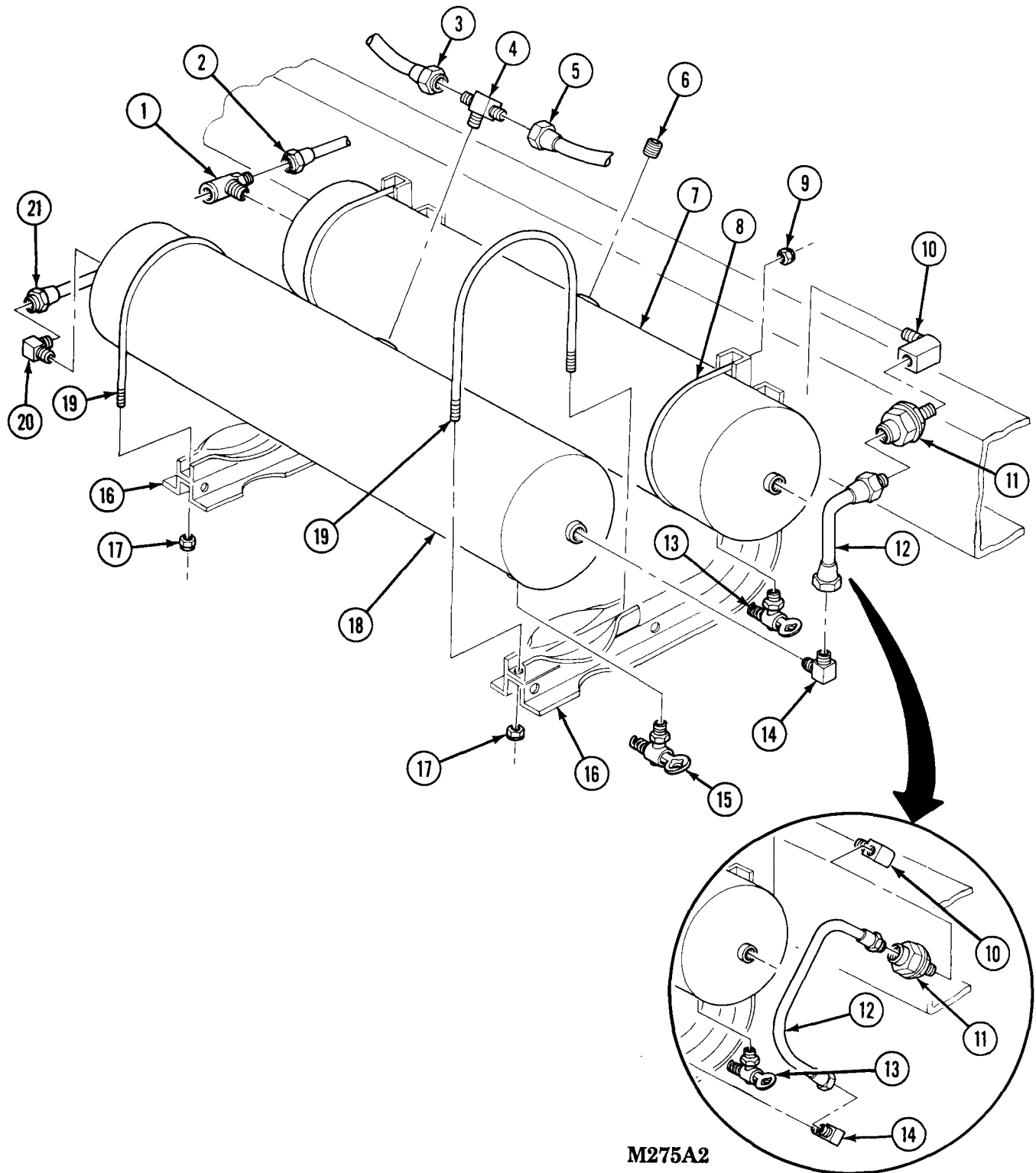

**M275A2**

- FOLLOW-ON TASKS:
- Install air system safety valve (para. 8-20).
  - Start engine (TM 9-2320-361-10), build up air pressure, and check for leaks.
  - Install right-rear splash shield (M756A2) (para. 12-103).

## 8-24. AIR RESERVOIRS REPLACEMENT

This task covers:

### a. Removal

### b. Installation

INITIAL SETUP:

#### APPLICABLE MODELS

All (except M275A2, M342A2, and M764)

#### MATERIALS/PARTS

Two locknuts  
 Antiseize tape (Appendix C, Item 27)  
 Sealing compound (Appendix C, Item 25)

#### REFERENCES (TM)

TM 9-2320-361-10  
 TM 9-2320-361-20P

#### EQUIPMENT CONDITION

- Parking brake set (TM 9-2320-361-10).
- Spare tire removed (TM 9-2320-361-10).
- Delivery pump front propeller shaft (M50A2) removed (para. 12-50).
- Delivery pump front propeller shaft removed (M49A2C and M50A3) (para. 12-51).
- Air system safety valve removed (para. 8-20).

### a. Removal

#### NOTE

- Perform steps 1 through 7 for vehicles equipped with air reservoir drain kit.
- Perform steps 1 and 2 for M50A3, M50A2, M109A3, M185A3, M35A2C, and M35A2 vehicles.

1. Remove nut (8), screw (5), two clamps (7), and cables (6) from bracket (4).
2. Loosen two nuts (3) on tiedown bracket (2) and remove bracket (4) from frame (1). Tighten nuts (3).

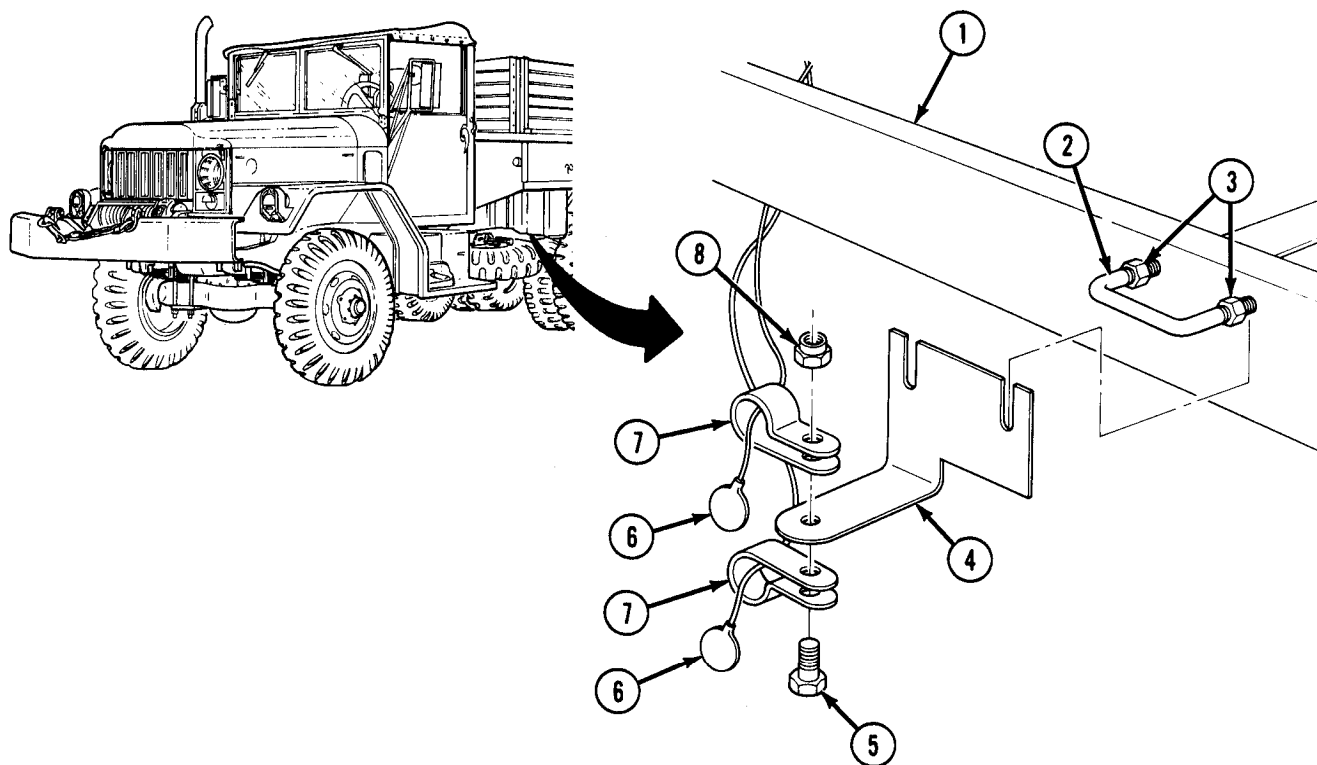

**8-24. AIR RESERVOIRS REPLACEMENT (Contd)**

**NOTE**

- Perform steps 3 through 5 for M36A2 vehicle.
- Perform steps 3 and 4 on vehicles without hole in bottom flange of frame rail.
- Perform step 5 on vehicles with hole in bottom flange of frame rail.

3. Remove nut (8), screw (5), two clamps (7), and cables (6) from bracket (11).
4. Remove nut (9), washer (10), screw (12), and bracket (11) from frame (1).
5. Remove nut(9), lockwasher (14), screw (5), and two clamps (7) from frame rail (1).
6. Remove two valves (15) and (16) from elbows (17).
7. Remove elbows (17) from air tanks (13) and (18).

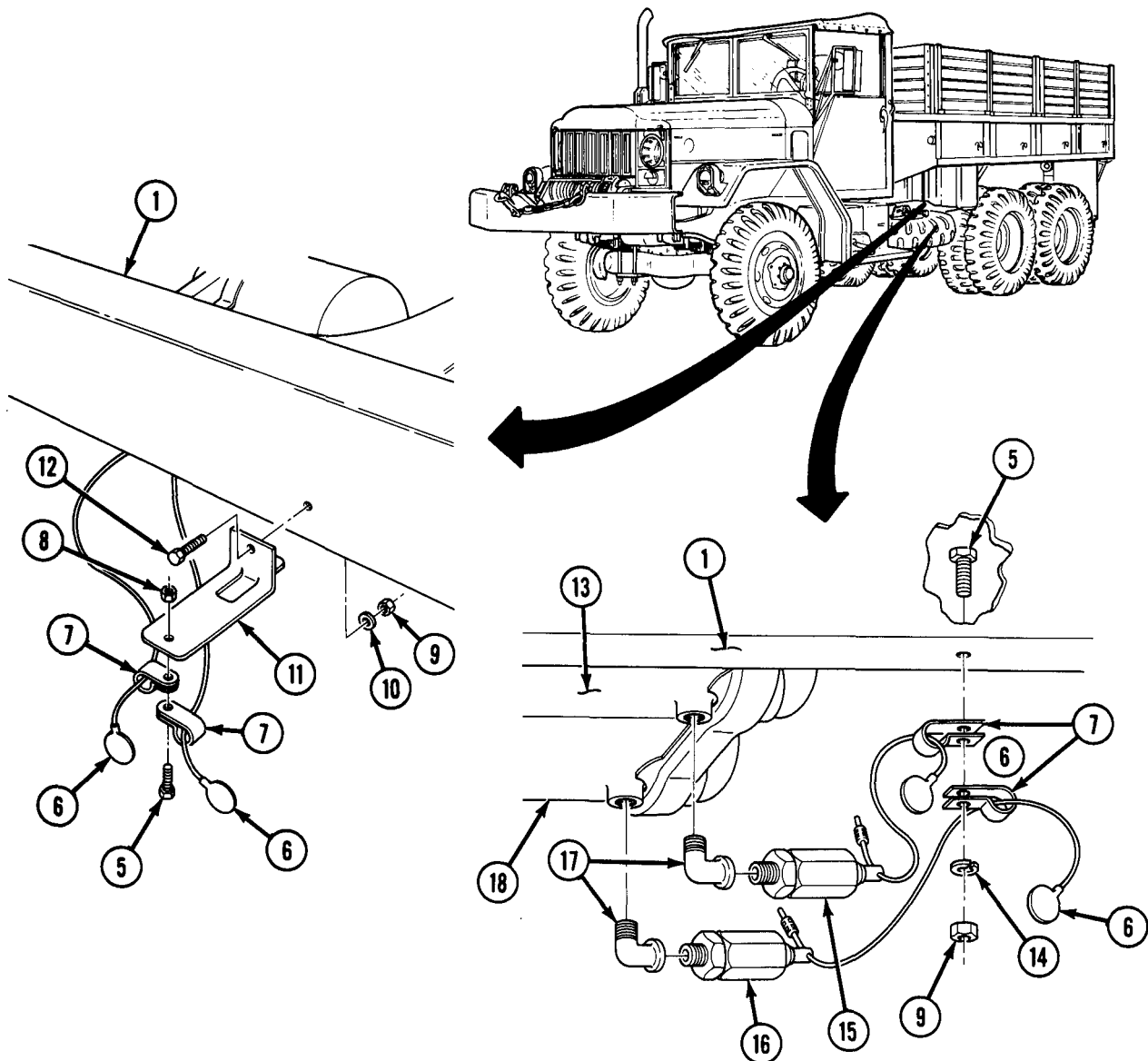

## 8-24. AIR RESERVOIRS REPLACEMENT (Contd)

### NOTE

Tag air lines and hoses for installation.

8. Remove two locknuts (13), bolts (4), and retaining brackets (7) and (21) from two air reservoirs (20) and (12) and two supports (19) and (22). Discard locknuts (13).

### NOTE

Slide air reservoirs to gain access to air lines and fittings.

9. Remove air line (5) from elbow (6) and valve (8).
10. Remove two air lines (15) and (18) from tee fitting (16) and elbow (17).
11. Remove two air lines (1) and (3) from tee fitting (2).
12. Remove two air reservoirs (12) and (20) from two supports (22) and (19).

### NOTE

Record location and position of all fittings for installation.

13. Remove two elbows (6) and (17), tee fitting (2), and draincock (10) from air reservoir (20).
14. Remove valve (8), elbow (9), draincock (11), plug (14), and tee fitting (16) from air reservoir (12).
15. Inspect all fittings, valves, draincocks, elbows, and plug for stripped threads, cracks, or breaks. If damaged, replace.

### b. Installation

### NOTE

Wrap all male pipe threads with antiseize tape before installation.

1. Install two elbows (17) and (6), tee fitting (2), and draincock (10) in air reservoir (20).
2. Install tee fitting (16), plug (14), draincock (11), elbow (9), and valve (8) on air reservoir (12).
3. Position two air reservoirs (20) and (12) on two supports (22) and (19).

### NOTE

Slide air reservoirs to gain access to air lines and fittings.

4. Install two air lines (1) and (3) on tee fitting (2).
5. Install two air lines (15) and (18) on tee fitting (16) and elbow (17).
6. Install air line (5) on valve (8) and elbow (6).
7. Secure two air reservoirs (12) and (20) to two supports (19) and (22) with two retaining brackets (21) and (7), bolts (4), and new locknuts (13).

8-24. AIR RESERVOIRS REPLACEMENT (Contd)

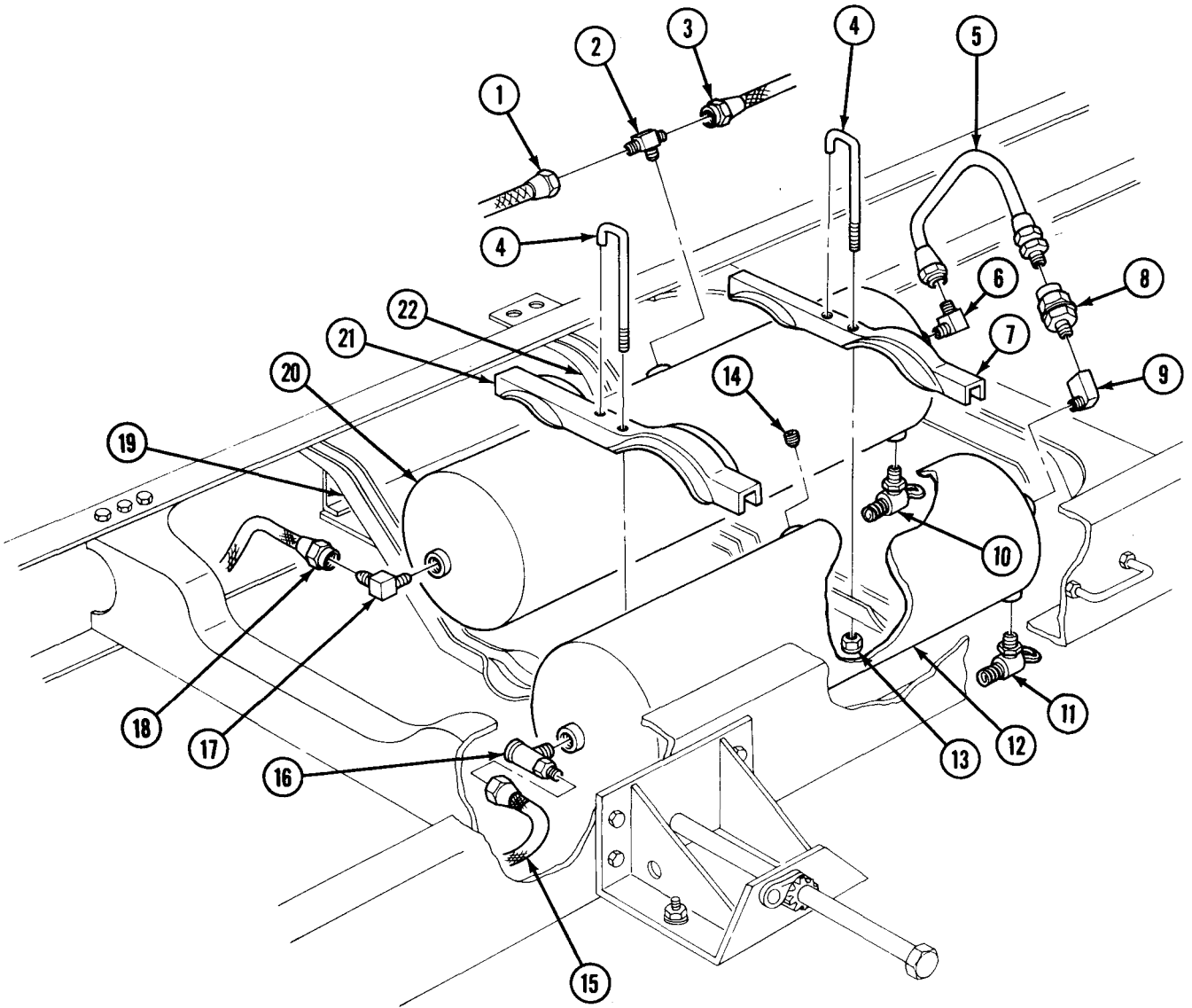

8-24. AIR RESERVOIRS REPLACEMENT (Contd)

**NOTE**

- Apply pipe sealant to male pipe threads during assembly and installation.
- Perform steps 13 through 15 for M36A2 vehicle.
- Perform step 13 for vehicles with hole in bottom flange of frame rail.
- Perform steps 14 and 15 for vehicles without hole in bottom flange of frame rail.

8. Install elbow (10) on right tank (11).
9. Install valve (9) on elbow (10).
10. Install elbow (10) on left tank (2).
11. Install valve (8) on elbow (10).
12. Turn valves (8) and (9) so that they are facing rear of vehicle.
13. Install cables (5) on frame (1) with two clamps (4), screw (3), lockwasher (6), and nut (7).
14. Install bracket (14) on frame (1) with screw (15), washer (13), and nut (12).
15. Install cables (5) on bracket (14) with screw (3), two clamps (4), and nut (7).

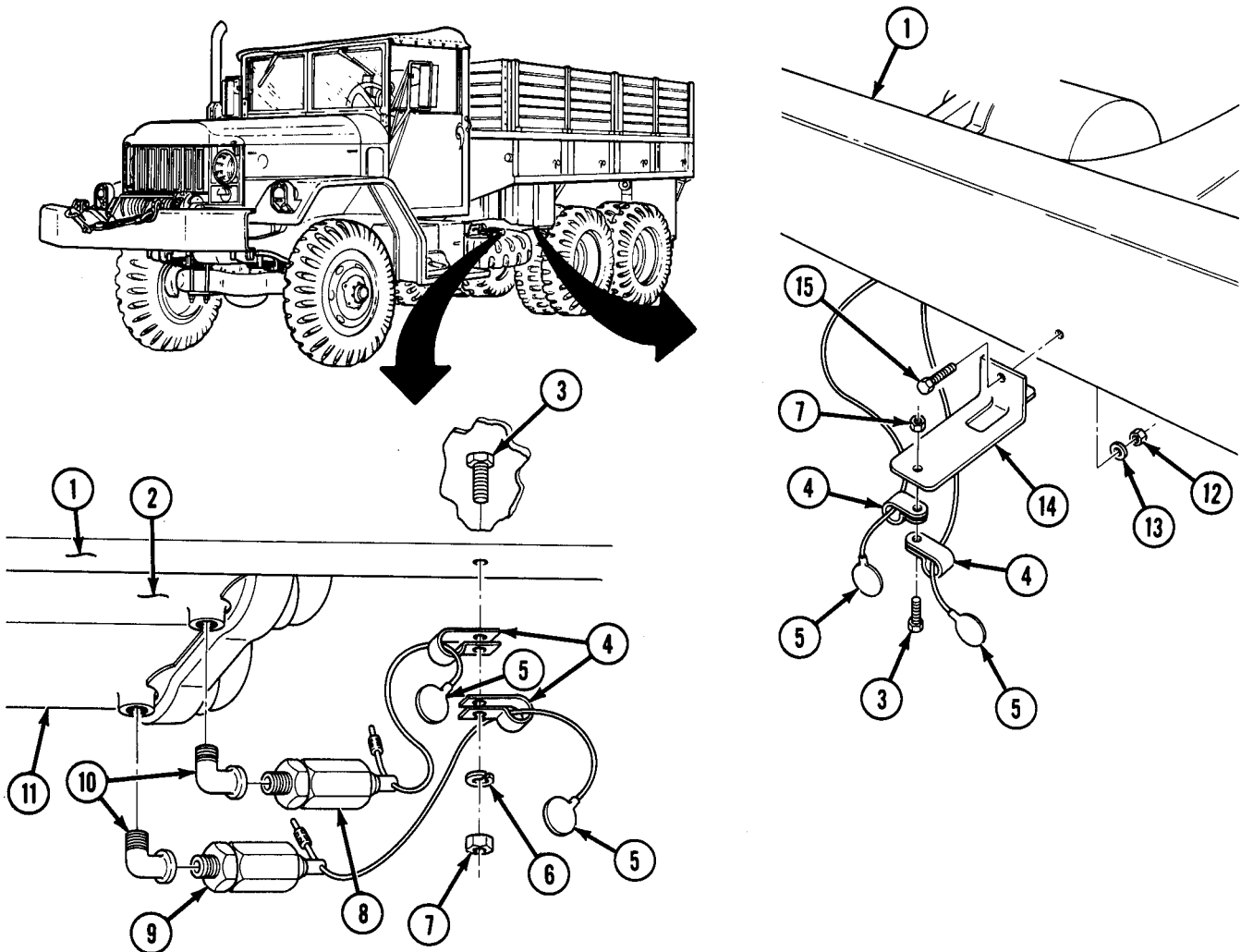

## 8-24. AIR RESERVOIRS REPLACEMENT (Contd)

### NOTE

Perform steps 16 through 18 for M50A3, M50A2, M109A3, M185A3, M35A2C, and M35A2 vehicles.

16. Loosen two nuts (17) on tiedown bracket (16) on left side of frame (1).
17. Install bracket (18) between tiedown bracket (16) and frame (1). Tighten two nuts (17) to secure bracket (18).
18. Install cables (5) on bracket (18) with two clamps (4), screw (3), and nut (7).

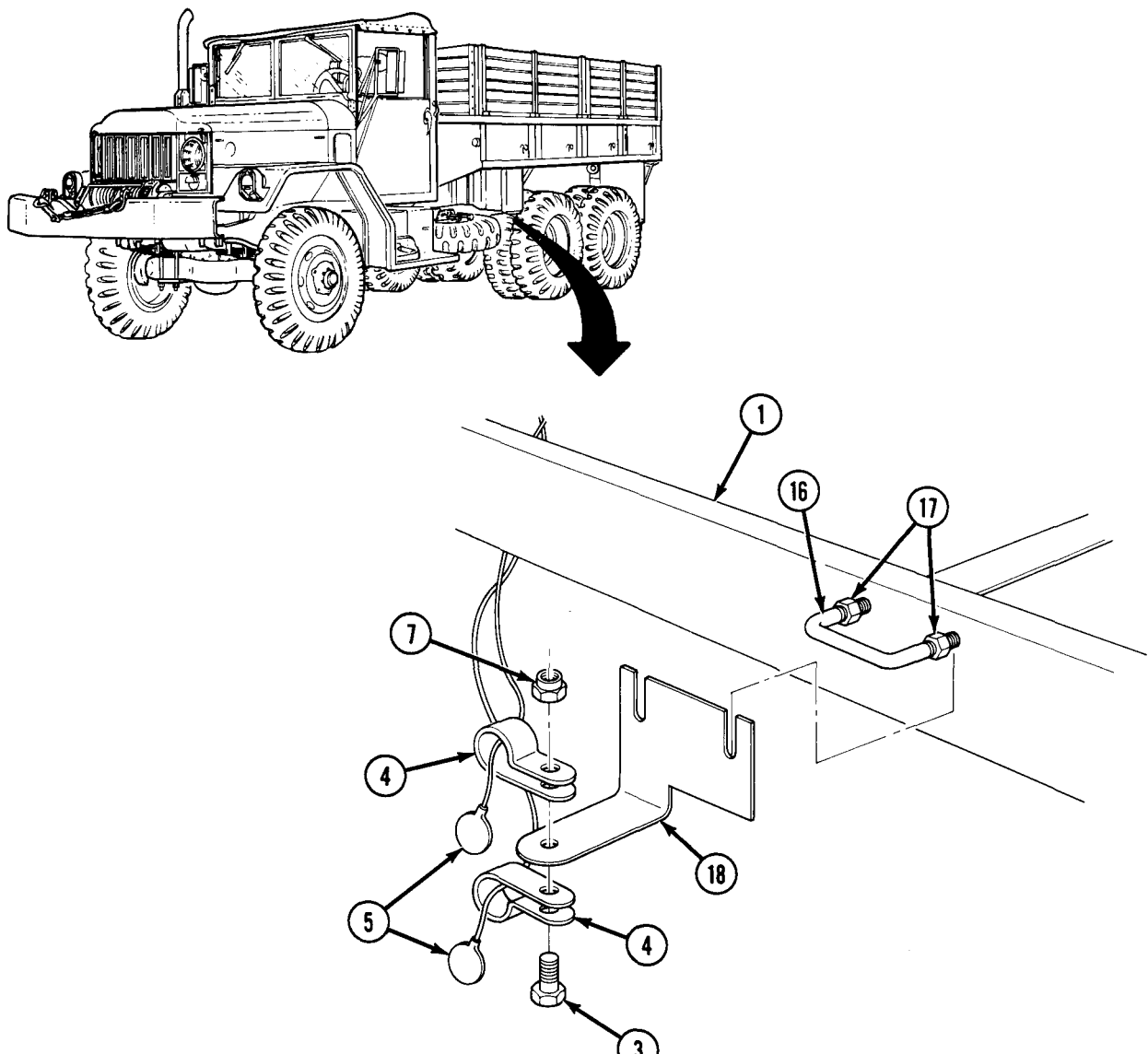

- FOLLOW-ON TASKS:
- Install air system safety valve (para. 8-20).
  - Install delivery pump front propeller shaft (M49A2C and M50A3) (para. 12-51).
  - Install delivery pump front propeller shaft (M50A2) (para. 12-50).
  - Install spare tire (TM 9-2320-361-10).



**8-25. AIR RESERVOIRS REPLACEMENT (M764)**

This task covers:

**a. Removal**

**b. Installation**

**INITIAL SETUP:**

APPLICABLE MODELS

M764

MATERIALS/PARTS

Eight locknuts

Antiseize tape(Appendix C, Item 27)

PERSONNEL REQUIRED

Two

REFERENCES (TM)

TM 9-2320-361-10

TM 9-2320-361-20P

EQUIPMENT CONDITION

- Parking brake set (TM 9-2320-361-10).
- Spare tire removed (TM 9-2320-361-10).
- Air system safety valve removed (para. 8-20).

**NOTE**

Tag all air lines for installation.

1. Remove two air lines (2) and (3) from tee (5).
2. Remove air line (1) from tee (22).
3. Remove air line (10) from elbow (9) and valve (11).

**NOTE**

Assistant will help with steps 4 and 5.

4. Remove four locknuts (4), screws (8), and two retaining straps (7). Discard locknuts (4).
5. Remove air reservoir (6) from vehicle.
6. Remove air line (21) from elbow (19).

**NOTE**

Assistant will help with steps 7 and 8.

7. Remove four locknuts (20), screws (15), and two retaining straps (16). Discard locknuts (20).
8. Remove air reservoir (18) from vehicle.

**NOTE**

Record location and position of all fittings for installation.

9. Remove two tee fittings (5) and (22), elbow (9), and draincock (13) from air reservoir (6).
10. Remove valve (11), two elbows (12) and (19), plug (14), and draincock (17) from air reservoir (18).

**b. Installation**

**NOTE**

Wrap all male pipe threads with antiseize tape before installation.

1. Install two elbows (19) and (12), plug (14), and draincock (17) on air reservoir (18) and valve (11) in elbow (12).
2. Install two tee fittings (22) and (5), elbow (9), and draincock (13) on air reservoir (6).

**NOTE**

Assistant will help with step 3.

3. Install air reservoir (6) with two retaining straps (7), four screws (8), and new locknuts (4).
4. Install two air lines (3) and (2) on tee fitting (5).
5. Install air line (1) on tee fitting (22).

## 8-25. AIR RESERVOIRS REPLACEMENT (M764) (Contd)

6. Install airline (10) on elbow (9).

### NOTE

Assistant will help with step 7.

7. Install air reservoir (18) with two retaining straps (16), four screws (15), and new locknuts (20).

8. Install air line (21) on elbow (19).

9. Install air line (10) on valve (11).

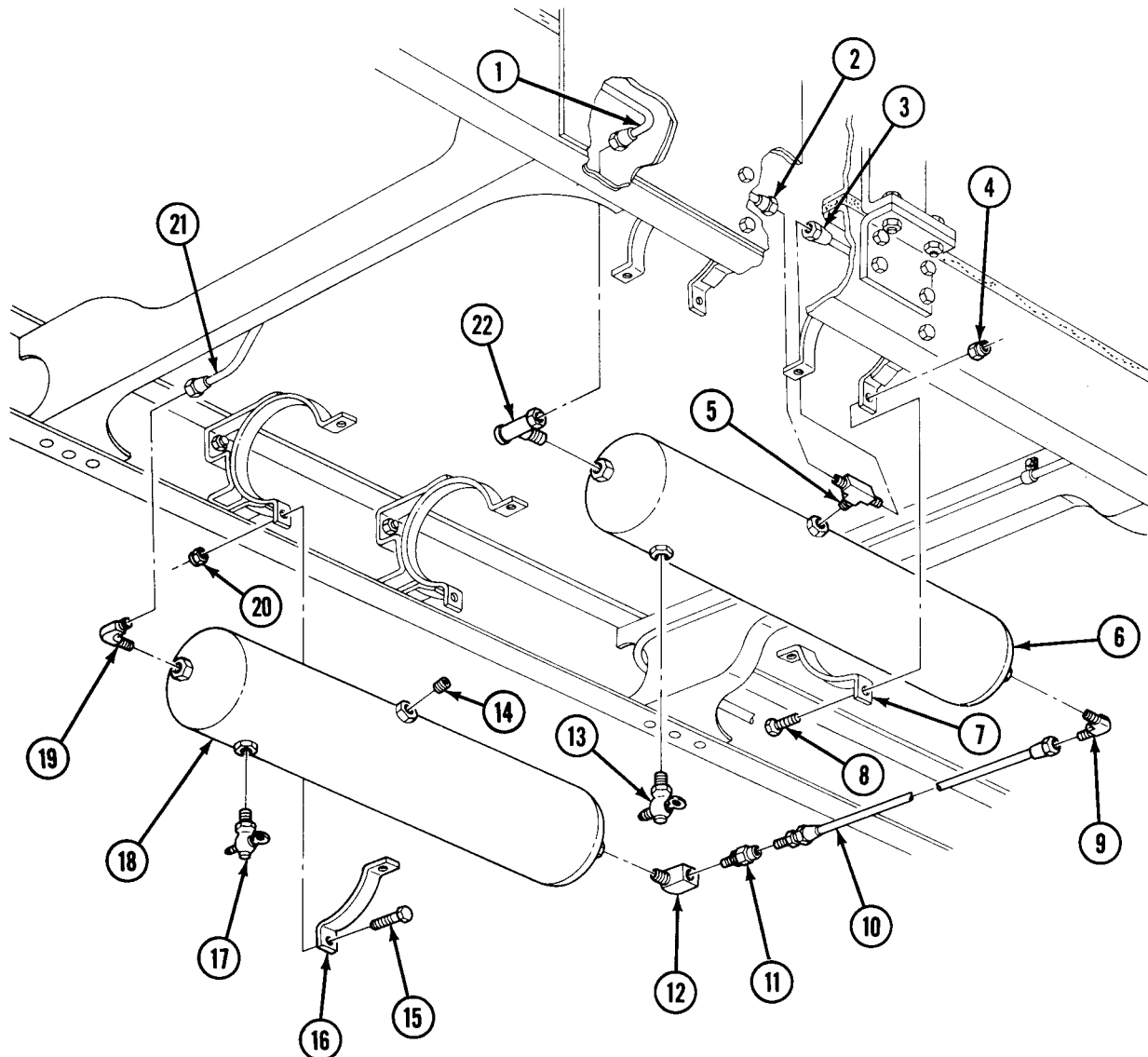

- FOLLOW-ON TASKS:
- Install air system safety valve (para. 8-20).
  - Start engine (TM 9-2320-361-10), build up air pressure, and check for leaks.
  - Install spare tire (TM 9-2320-361-10).

**8-26. AIR COMPRESSOR AND PULLEY REPLACEMENT**

This task covers:

- |  |  |
|--|--|
| <p><b>a. Removal</b><br/><b>b. Disassembly</b></p> | <p><b>c. Assembly</b><br/><b>d. Installation</b></p> |
|--|--|

**INITIAL SETUP:**

APPLICABLE MODELS

All

MATERIALS/PARTS

Three gaskets  
Eight lockwashers  
Antiseize tape (Appendix C, Item 27)  
Cap and plug set (Appendix C, Item 8)

REFERENCES (TM)

TM 9-2320-361-10  
TM 9-2320-361-20P

EQUIPMENT CONDITION

- Air reservoir drained (TM 9-2320-361-10).
- Air compressor drivebelt removed (para. 8-28).

GENERAL SAFETY INSTRUCTIONS

Do not disconnect air lines before draining air reservoirs.  
Allow air compressor to cool before handling.

**a. Removal**

**WARNING**

- Do not disconnect air lines before draining air reservoirs. Small parts under pressure may shoot out with high velocity, causing injury to personnel.
- Air compressor becomes hot during operation. Allow compressor to cool before handling, or injury to personnel may result.

**NOTE**

Plug air lines as they are disconnected.

1. Remove air line (7) from adapter (4).

**NOTE**

On some air compressors, the air governor air line is on front of compressor near pulley.

2. Remove air governor air line (2) from elbow (3).
3. Remove screw (14), clamp (13), and fuel pump return line (1) from air compressor (10). Tie fuel pump return line (1) out of way.
4. Install screw (14) in air compressor (10).
5. Remove screw (5) and bracket (6) from air compressor (10).
6. Install screw (5) in air compressor (10).
7. Remove four nuts (8), lockwashers (9), and bracket (15) from base of air compressor (10). Discard lockwashers (9).
8. Tie tachometer cable (16) and bracket (15) out of way.
9. Remove air compressor (10) and gasket (11) from air compressor support (12). Discard gasket (11).

8-26. AIR COMPRESSOR AND PULLEY REPLACEMENT (Contd)

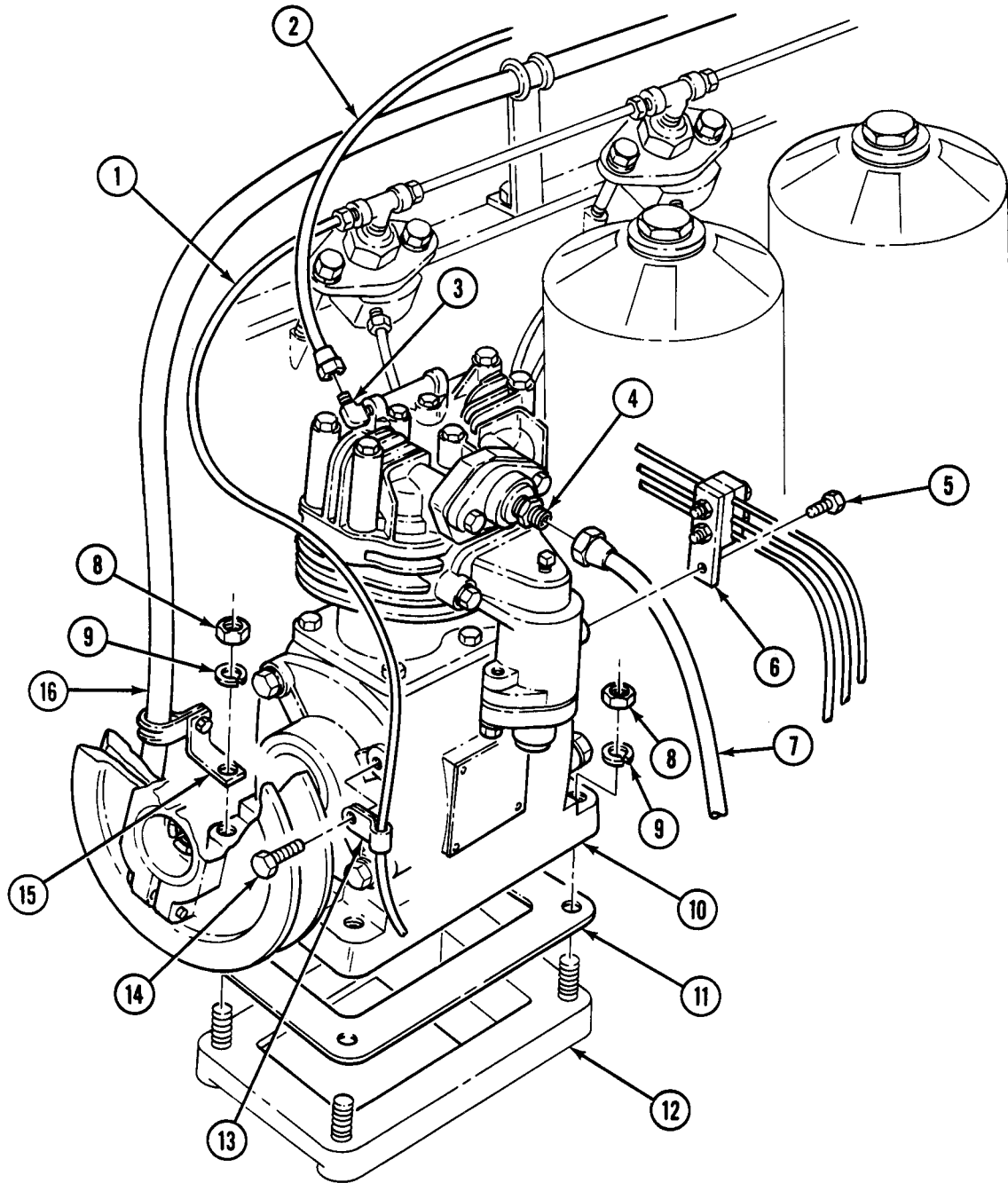

## 8-26. AIR COMPRESSOR AND PULLEY REPLACEMENT (Contd)

1. Holding pulley flange (15), remove nut (13) from crankshaft (16).
2. Remove adjustable puller flange (14) from pulley flange (15).
3. Remove pulley flange (15) from crankshaft (16).

### NOTE

Some compressors have a key in crankshaft and others use a tapered shaft.

4. Remove key (12), if present, from crankshaft (16).
5. Remove adapter (6) from discharge housing (3).
6. Remove two screws (5), lockwashers (4), discharge housing (3), and gasket (2) from air compressor (11). Discard lockwashers (4) and gasket (2).
7. Remove two screws (7), lockwashers (8), intake air cleaner (9) and gasket (10) from air compressor (11). Discard lockwashers (8) and gasket (10).
8. Remove elbow (1) from air compressor (11).

### c. Assembly

### CAUTION

Remove shipping plate and gasket from new air compressor before installation, or damage to equipment may result.

### NOTE

- Clean all fittings and housings before installation.
- Wrap all male pipe threads with antiseize tape before installation.

1. Install elbow (1) on air compressor (11).
2. Install intake air cleaner (9) and new gasket (10) on air compressor (11) with two new lockwashers (8) and screws (7).
3. Install discharge housing (3) and new gasket (2) on air compressor (11) with two new lockwashers (4) and screws (5).
4. Install adapter (6) on discharge housing (3).
5. Install key (12), if used, in crankshaft (16).
6. Install pulley flange (15) on crankshaft (16) alining keyway in pulley flange (15) to key (12).
7. Holding pulley flange (15), install nut (13) on threaded end of crankshaft (16).
8. Install adjustable pulley flange (14) on pulley flange (15).

### d. Installation

1. Install new gasket (24) over studs on compressor support (25).
2. Install air compressor (11), tachometer cable (29), and bracket clamp (28) on air compressor support (26) with four new lockwashers (23) and nuts (22).
3. Remove screw (19) from air cleaner (9) and install bracket (20) with screw (19).
4. Remove screw (27) from air compressor (11) and install fuel return line (17) and clamp (26) on air compressor (11) with screw (27).
5. Install air line (21) on adapter (6).
6. Install governor air line (18) on elbow (1).

8-26. AIR COMPRESSOR AND PULLEY REPLACEMENT (Contd)

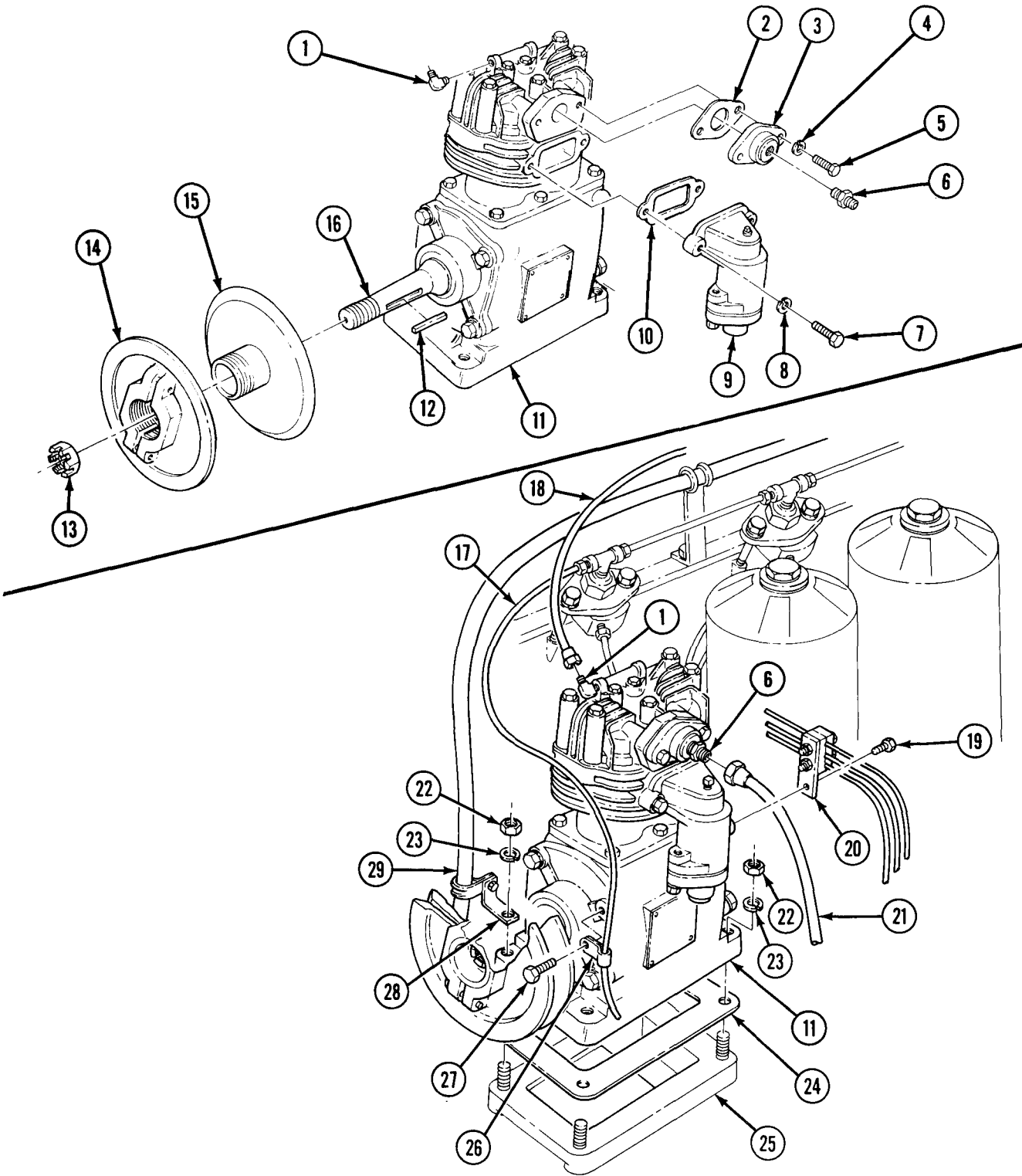

FOLLOW-ON TASK: Install air compressor drivebelt (para. 8-28).

**8-27. AIR COMPRESSOR SERVICING**

This task covers:

- |   |   |
|---|---|
| <p><b>a. Removal</b><br/> <b>b. Disassembly</b><br/> <b>c. Cleaning</b></p> | <p><b>d. Assembly</b><br/> <b>e. Installation</b></p> |
|---|---|

**INITIAL SETUP:**

APPLICABLE MODELS

All

MATERIALS/PARTS

Gasket  
 Two lockwashers  
 Drycleaning solvent (Appendix C, Item 26)

REFERENCES (TM)

TM 9-2320-361-10  
 TM 9-2320-361-20P

EQUIPMENT CONDITION

- Parking brake set (TM 9-2320-361-10).
- Hood raised and left side panel down (TM 9-2320-361-10).

GENERAL SAFETY INSTRUCTIONS

- Keep fire extinguisher nearby when using drycleaning solvent.
- Compressed air source will not exceed 30 psi (207 kPa).
- Eyeshields must be worn when cleaning with compressed air.

**a. Removal**

1. Loosen two screws (5) on intake air cleaner (2).
2. Remove two screws (4), lockwashers (3), intake air cleaner (2), and gasket (1) from air compressor (6). Discard lockwashers (3) and gasket (1).

**b. Disassembly**

1. Remove two screws (5) from intake air cleaner (2).
2. Remove cap (10), spring (9), plate (8), and filter (7) from body of intake air cleaner (2).

**c. Cleaning**

**WARNING**

Drycleaning solvent is flammable and will not be used near open flame. Use only in well-ventilated places. Failure to do so may result in injury to personnel.

Compressed air source will not exceed 30 psi (207 kPa). When cleaning with compressed air, eyeshields must be worn. Failure to wear eyeshields may result in injury to personnel.

1. Wash filter (7) in drycleaning solvent.
2. Using compressed air source, clean and dry filter (7).

**d. Assembly**

1. Install filter (7), plate (8), and spring (9) in body of intake air cleaner (2).
2. Install cap (10) on intake air cleaner (2) with two screws (5), Tighten screws (5) finger tight.

## 8-27. AIR COMPRESSOR SERVICING (Contd)

## e. Installation

1. Install new gasket (1) and intake air cleaner (2) on air compressor (6) with two new lockwashers (3) and screws (4).
2. Tighten two screws (5).

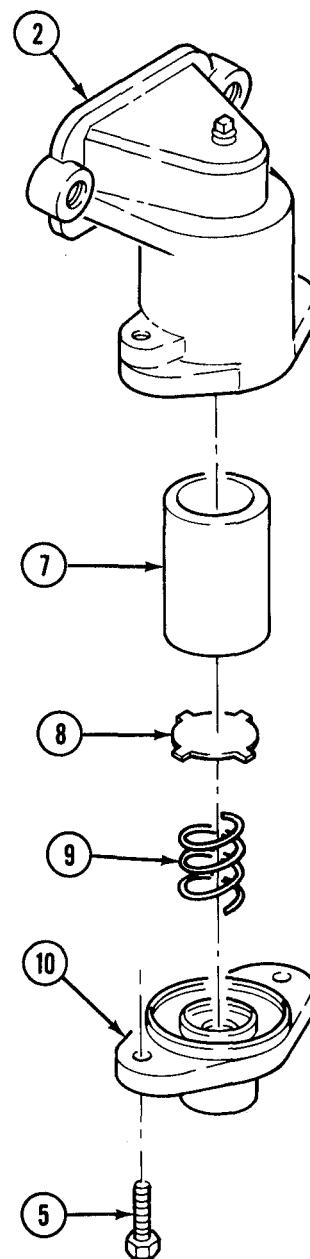
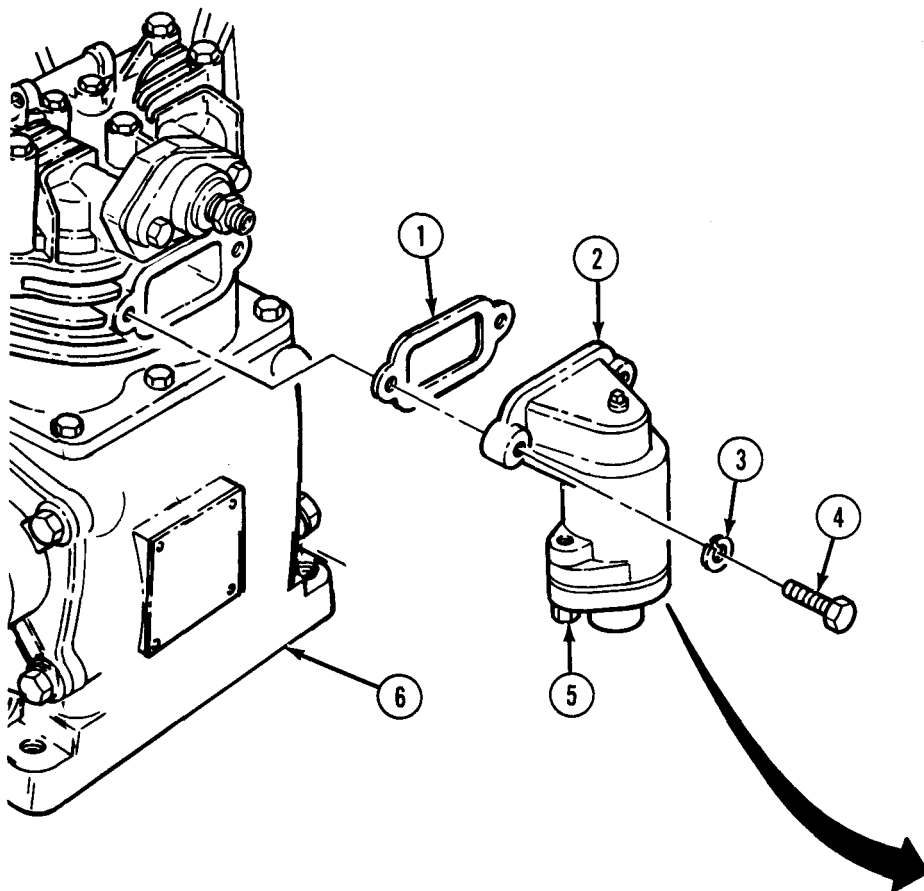

- FOLLOW-ON TASKS:
- Start engine (TM 9-2320-361-10), buildup air pressure, and check air compressor operation.
  - Raise and lock side panel and lower hood (TM 9-2320-361-10).



## 8-28. AIR COMPRESSOR DRIVEBELT REPLACEMENT

This task covers:

- a. Removal
- b. Installation

c. Adjustment

### INITIAL SETUP:

APPLICABLE MODELS

All

SPECIAL TOOLS

Air compressor pulley spanner wrench  
(NSN 5120-00-070-7809)

MATERIALS/PARTS

Two lockwashers

REFERENCES (TM)

TM 9-2320-361-10

TM 9-2320-361-20P

EQUIPMENT CONDITION

- Parking brake set (TM 9-2320-361-10).
- Hood raised and secured (TM 9-2320-361-10).
- Alternator belts removed (para. 4-2).
- Radiator removed (para. 3-42).

GENERAL SAFETY INSTRUCTIONS

Ensure fuel shutoff valve is OFF before tuning over engine.

### a. Removal

1. Remove two screws (2) and lockwashers (1) from adjustable pulley flange (4). Discard lockwashers (1).
2. Using puller wrench and holding pulley flange (3), turn adjustable pulley flange (4) counterclockwise to loosen drivebelt (5).
3. Remove drivebelt (5) from crankshaft pulley (7), pulley flange (3), and adjustable pulley flange (4).

### b. Installation

1. Place drivebelt (5) between pulley flange (3) and adjustable pulley flange (4) and on crankshaft pulley (7).
2. Holding drivebelt (5) up, turn adjustable pulley flange (4) clockwise as far as possible by hand.
3. Turn adjustable pulley flange (4) on pulley flange (3) until there is no slack in drivebelt (5).

### c. Adjustment

#### WARNING

Ensure fuel shutoff valve is OFF before turning over engine. Failure to do this may result in injury to personnel.

1. Turn engine several revolutions, by turning crankshaft bolt (8), to equalize tension on both sides of drivebelt (5).
2. Holding straight edge (6) along drivebelt (5), use 6-inch rule to push in center of drivebelt (5). Correct drivebelt tension is 0.75 in. (1.905 cm) with firm finger grip on 6-inch rule.
3. Using pulley wrench and holding pulley flange (3), adjust drivebelt (5) tension:
  - a. Turn adjustable pulley flange (4) counterclockwise to loosen tension on drivebelt (5).
  - b. Turn adjustable pulley flange (4) clockwise to increase tension on drivebelt (5).
4. When drivebelt (5) tension is correct, install two new lockwashers (1) and screws (2) in adjustable pulley flange (4).

8-28. AIR COMPRESSOR DRIVEBELT REPLACEMENT (Contd)

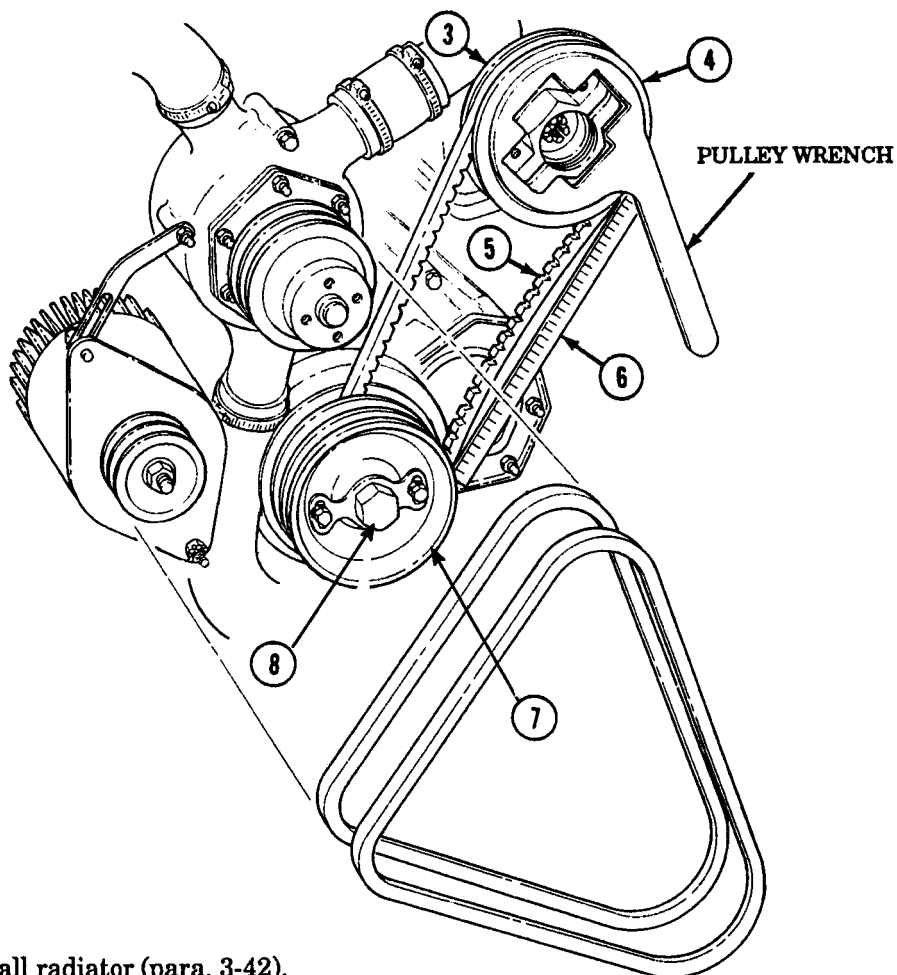
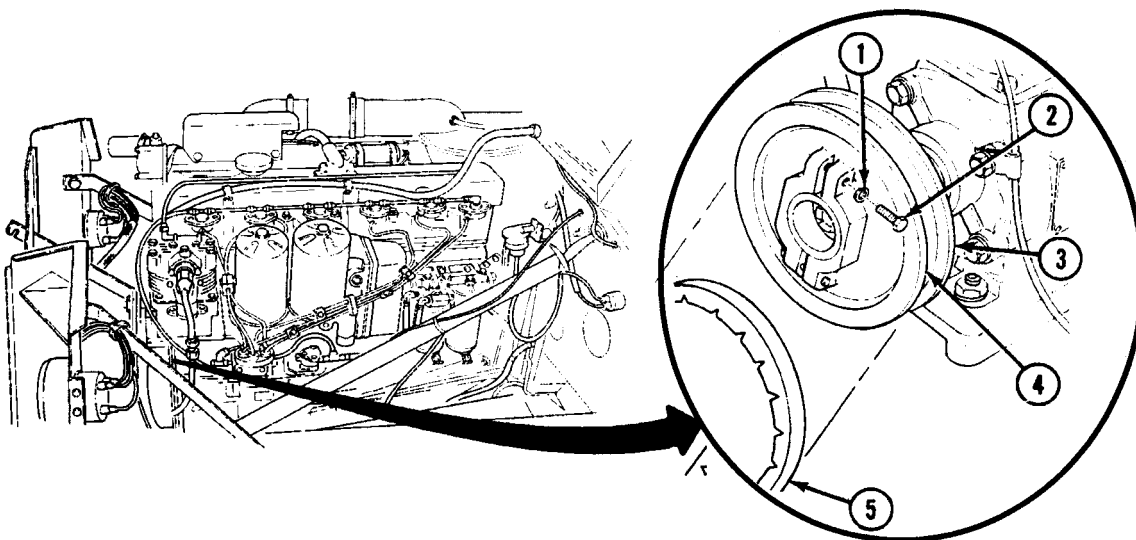

- FOLLOW-ON TASKS:**
- Install radiator (para. 3-42).
  - Install alternate; belts (para. 4-2).
  - Start engine (TM 9-2320-361-10), build up air pressure, and check compressor operation.

**8-29. AIR COMPRESSOR GOVERNOR MAINTENANCE**

This task covers:

- a. Removal
- b. Installation

c. Check and Adjustment

**INITIAL SETUP:**

APPLICABLE MODELS

All

SPECIAL TOOLS

Gage pressure dial indicating  
NSN 6685-00-387-9654

MATERIALS/PARTS

Two screws  
Antiseize tape (Appendix C, Item 27)

REFERENCES (TM)

TM 9-2320-361-10  
TM 9-2320-361-20P

EQUIPMENT CONDITION

- Parking brake set (TM 9-2320-361-10).
- Hood raised and secured (TM 9-2320-361-10).
- Air reservoirs drained (TM 9-2320-361-10).

GENERAL SAFETY INSTRUCTIONS

Do not disconnect air lines before draining air reservoirs.

**a. Removal**

**WARNING**

Do not disconnect air lines before draining air reservoirs. Small parts under pressure may shoot out with high velocity, causing injury to personnel.

**NOTE**

Tag all air lines and hoses for installation.

1. Remove two air lines (6) and (8) from tee fitting (7).
2. Remove air line (4) from adapter (3)
3. Remove two screws (5) and air compressor governor (10) from firewall (2). Discard screws (5).
4. Remove tee fitting (7), adapter (9), and adapter (3) from air compressor governor (10).

**NOTE**

Step 5 applies to M275A2 vehicles only.

5. Remove plug (1) from air compressor governor (10).

**b. Installation**

**NOTE**

- Wrap all male pipe threads with antiseize tape before installation.
- Step 1 applies to M275A2 vehicles.

1. Install plug (1) in port F of air compressor governor (10).
2. Install adapter (3) and adapter (9) on air compressor governor (10).
3. Install tee fitting (7) on adapter (9).
4. Install air compressor governor (10) on firewall (2) with two new screws (5).
5. Install air line (4) on adapter (3).
6. Install two air lines (8) and (6) on tee fitting (7).

8-29. AIR COMPRESSOR GOVERNOR AINTENANCE (Contd)

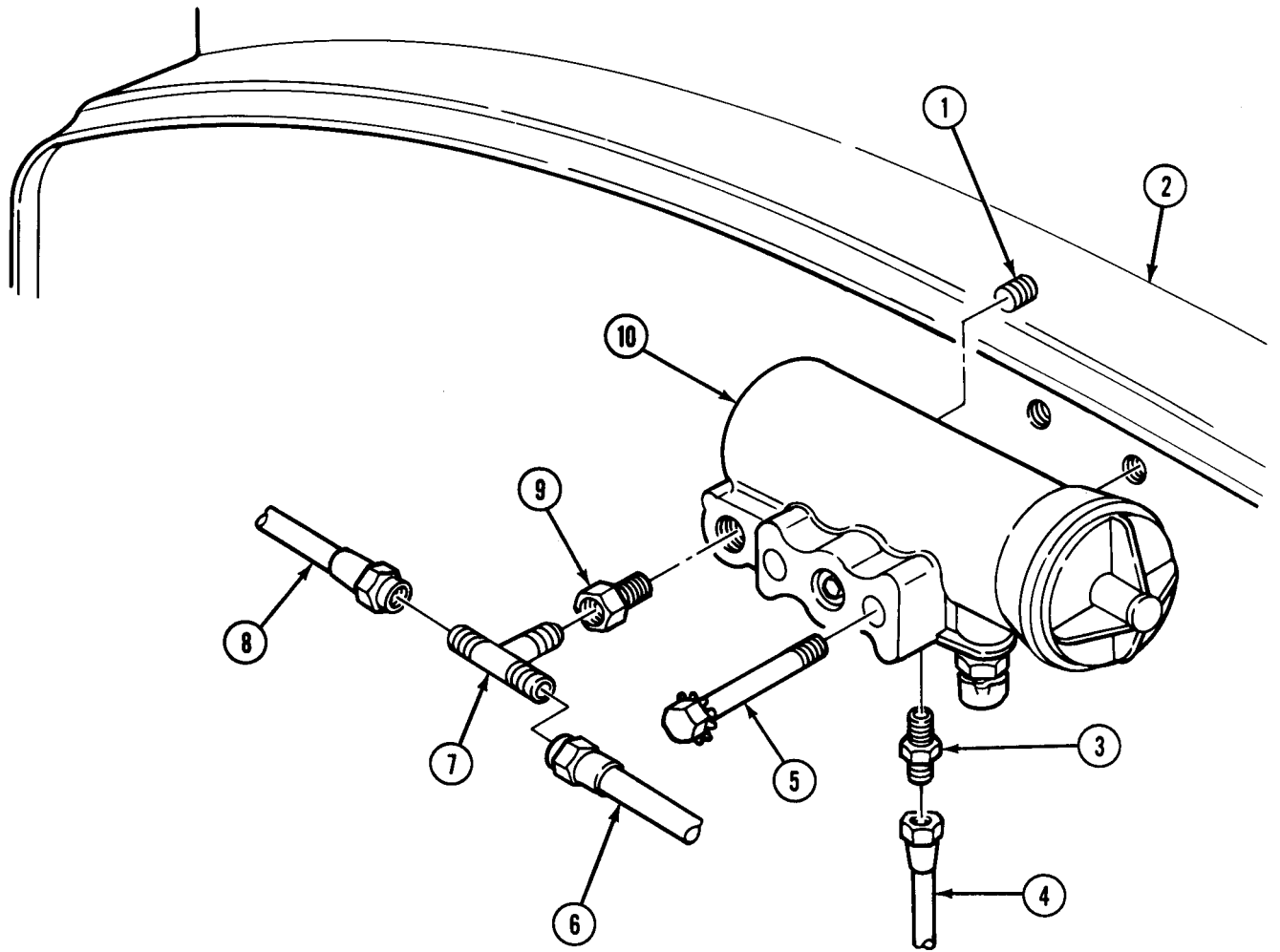

## 8-29. AIR COMPRESSOR GOVERNOR MAINTENANCE (Contd)

### c. Check and Adjustment

1. Start engine and buildup air pressure (TM 9-2320-361-10) until gage (4) reading is steady.
2. Check air pressure. Gage (4) should read 85-120 psi.
3. If air pressure gage (4) reading is correct, stop engine. End of task.
4. If air pressure gage (4) reading is too low:
  - a. Stop engine.
  - b. Remove cap (3), loosen jamnut (1), and turn screw (2) 1/4 turn clockwise.
  - c. Start engine and buildup air pressure (TM 9-2320-361-10). Check air pressure gage (4) reading. If still low, check for air leaks and repeat step b. until air pressure is correct.
  - d. Stop engine, tighten jamnut (1) on screw (2), and install cap (3).
5. If air pressure gage (4) reading is too high:
  - a. Stop engine.
  - b. Remove cap (6) from air valve (5).
  - c. Turn air valve (5) left and bleed air until gage (4) reads below 100 psi.
  - d. Close air valve (5) and replace cap (6).
  - e. Remove cap (3), loosen jamnut (1), and turn screw (2) 1/4 turn counterclockwise.
  - f. Start engine and buildup air pressure. Check air pressure gage (4) reading. If still high, repeat steps a. through e. until air pressure is correct.
  - g. Stop engine, tighten jamnut (1) on screw (2) and install cap (3).

8-29. AIR COMPRESSOR GOVERNOR MAINTENANCE (Contd)

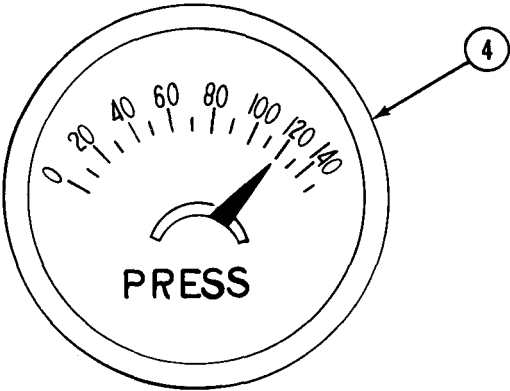
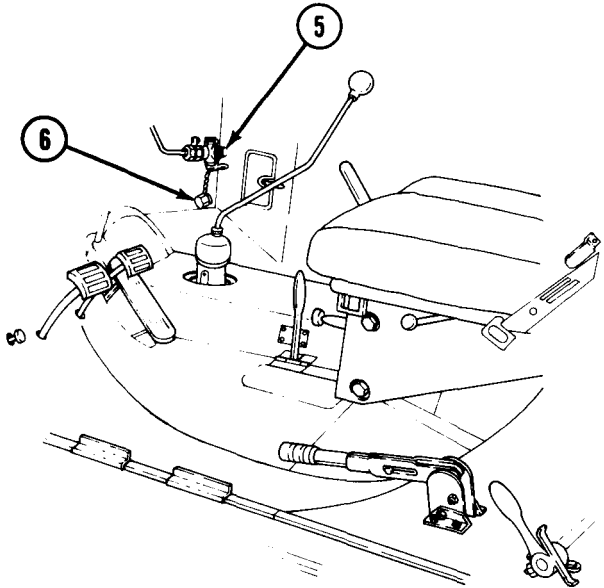
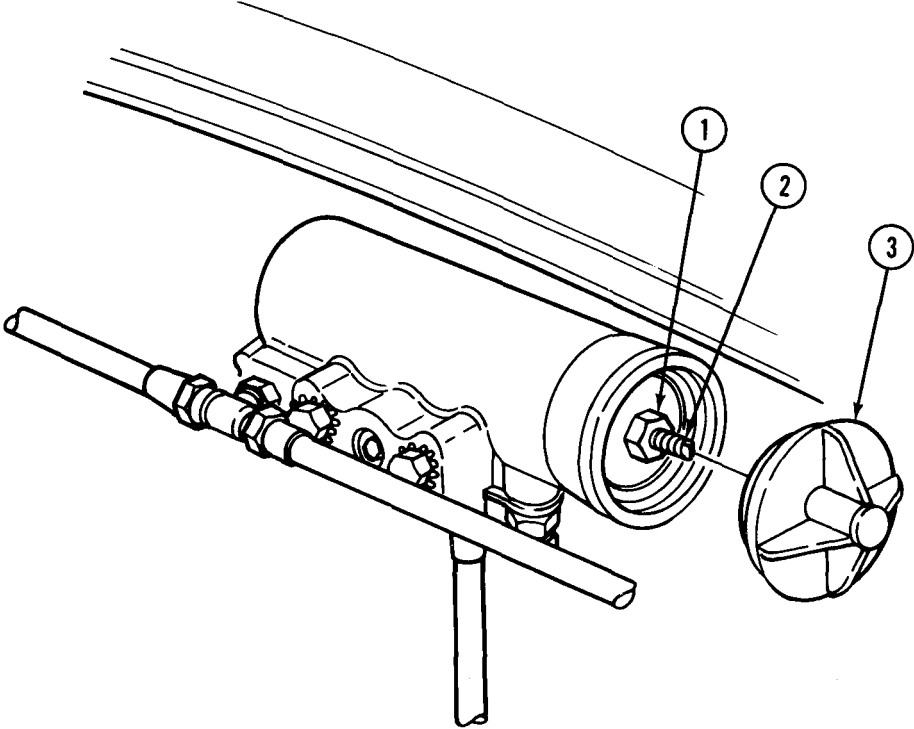

**8-30. QUICK-DISCONNECT COUPLING HALF MAINTENANCE**

This task covers:

- a. Leak Test
- b. Removal

c. Installation

**INITIAL SETUP:**

APPLICABLE MODELS

All

MATERIALS/PARTS

Seal  
 Detergent (Appendix C, Item 12)  
 Antiseize tape (Appendix C, Item 27)

REFERENCES (TM)

TM 9-2320-361-10  
 TM 9-2320-361-20P

EQUIPMENT CONDITION

- Parking brake set (TM 9-2320-361-10).
- Air reservoirs drained (TM 9-2320-361-10).

GENERAL SAFETY INSTRUCTIONS

Do not disconnect air couplings before draining air reservoirs.

**a. Leak Test**

1. Start engine (TM 9-2320-361-10) and buildup air pressure.
2. With dummy coupling (4) locked to coupling half (5), turn valve handle (1) to open position.
3. Test dummy coupling (4) and coupling seal (3) for leaks by coating with soapy water. Check if coupling seal (3) is leaking by watching for air bubbles. If leaking or damaged, replace.
4. Turn valve handle (1) to align with coupling half (5).
5. Stop engine (TM 9-2320-361-10).

**b. Removal**

**WARNING**

Do not disconnect air couplings before draining air reservoirs. Small parts under pressure may shoot out with high velocity, causing injury to personnel.

1. Remove dummy coupling (4) from coupling half (5).
2. Remove coupling half (5) from nipple (2).

**NOTE**

Perform step 3 only if coupling seal is damaged or leaking.

3. Remove coupling seal (3) from coupling half (5). Clean all coupling seal (3) remains from coupling half (5).

**c. Installation**

**NOTE**

- Perform step 1 if coupling was removed.
- Wrap male pipe threads with antiseize tape before installation.

1. Install new coupling seal (3) in coupling half (5).
2. Install coupling half (5) on nipple (2).
3. Install dummy coupling (4) on coupling half (5).

**8-30. QUICK-DISCONNECT COUPLING HALF MAINTENANCE (Contd)**

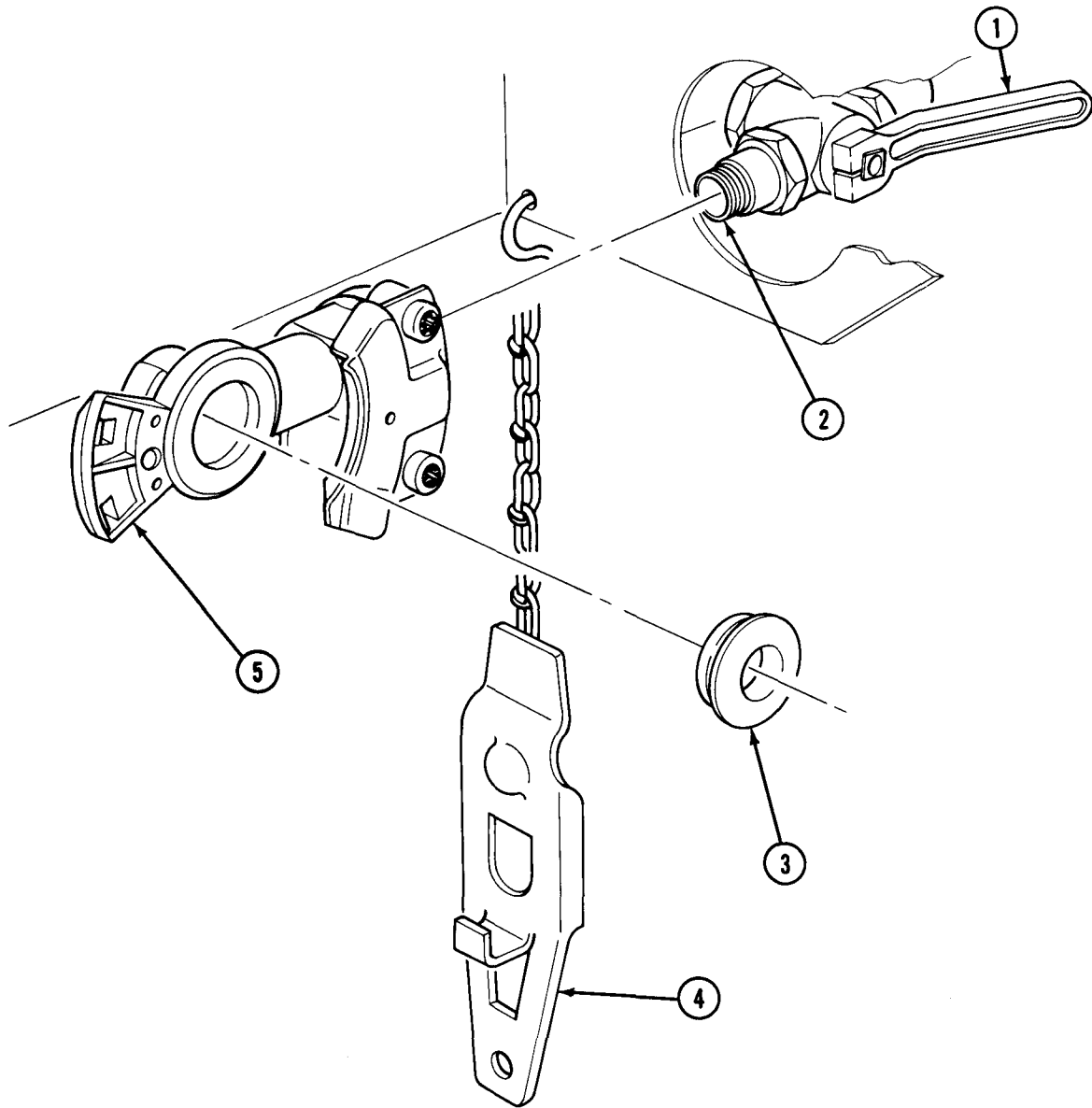

FOLLOW-ON TASK: Start engine (TM 9-2320-361-10), build up air pressure, and check for air leaks.



**8-31. AIRBRAKE CUTOFF VALVES AND COUPLINGS REPLACEMENT**

This task covers:

**a. Removal**

**b. Installation**

**INITIAL SETUP:**

APPLICABLE MODELS

All (except M275A2, M342A2, and M764)

MATERIALS/PARTS

Lockwasher

Antiseize tape (Appendix C, Item 27)

REFERENCES (TM)

TM 9-2320-361-10

TM 9-2320-361-20P

EQUIPMENT CONDITION

- Parking brake set (TM 9-2320-361-10).
- Air reservoirs drained (TM 9-2320-361-10).

GENERAL SAFETY INSTRUCTIONS

Do not disconnect air couplings before draining air reservoirs.

**WARNING**

Do not disconnect air couplings before draining air reservoirs. Small parts under pressure may shoot out with high velocity, causing injury to personnel.

**NOTE**

The right emergency and left service couplings and cutoff valves are replaced the same. This procedure covers the right side of service brake.

1. Remove dummy coupling (11) from coupling half (12).
2. Remove chain (13) and dummy coupling (11) from bracket (9).
3. Remove coupling half (12), nipple (10), and elbow (8) from cutoff valve (7).
4. Remove airline (2) and elbow (1) from connector (5).
5. Remove nut (3), cutoff valve (7) with connector (5), and lockwasher (4) from frame (14). Discard lockwasher (4).
6. Remove nut (6) and connector (5) from cutoff valve (7).

**b. Installation**

**NOTE**

Wrap all male pipe threads with antiseize tape before installation.

1. Install connector (5) and nut (6) on cutoff valve (7).
2. Install new lockwasher (4) and cutoff valve (7) with connector (5) on frame (14) with nut (3).
3. Install elbow (1) and air line (2) on connector (5).
4. Install elbow (8), nipple (10), and coupling half (12) on cutoff valve (7).
5. Install chain (13) and dummy coupling (11) on bracket (9).
6. Install dummy coupling (11) on coupling half (12).
7. Make sure cutoff valve (7) handle is turned to OFF position.

**8-31. AIRBRAKE CUTOFF VALVES AND COUPLINGS REPLACEMENT (Contd)**

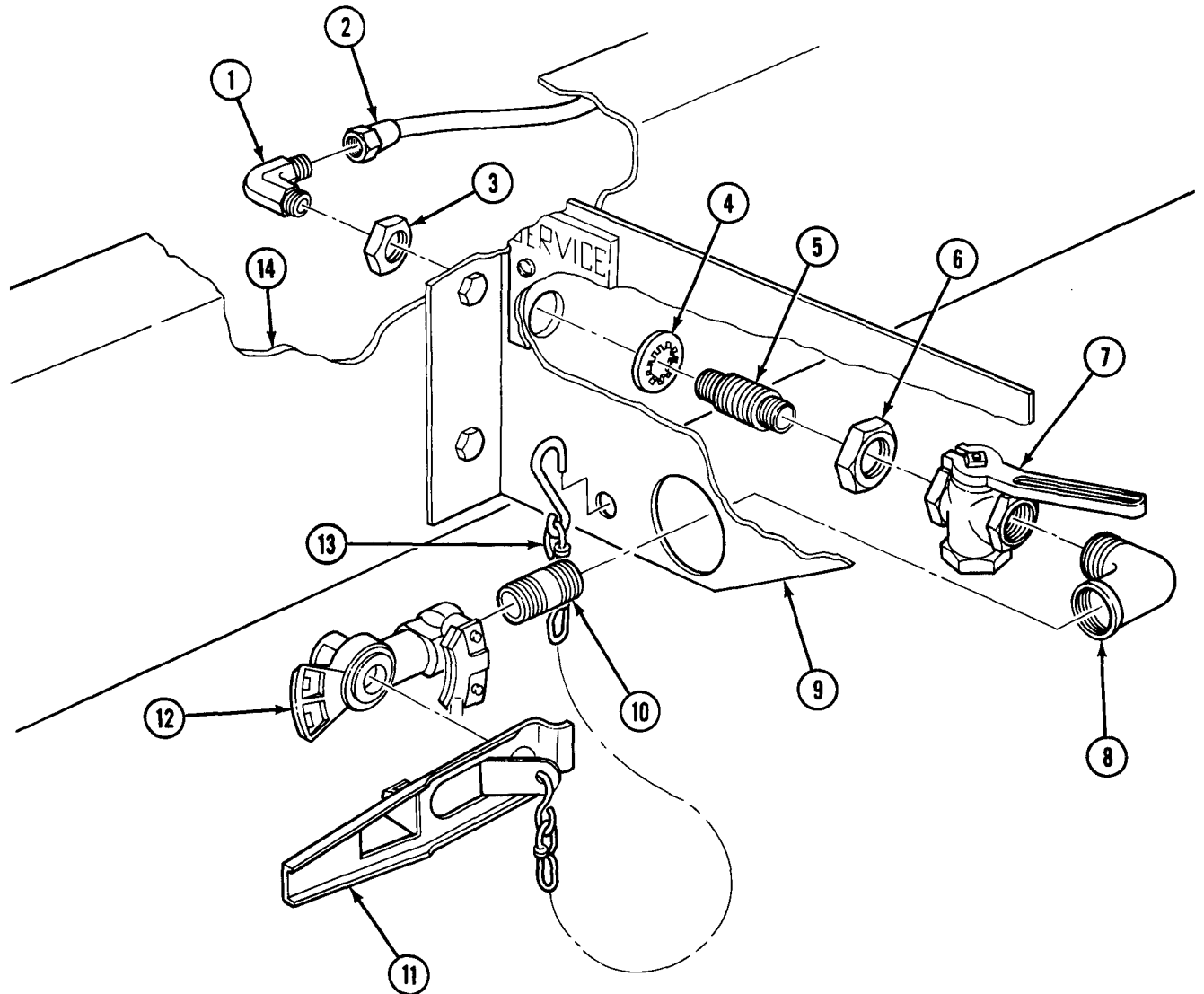

FOLLOW-ON TASK: Start engine (TM 9-2320-361-10), build up air pressure, and check for air leaks.

**8-32. AIRBRAKE CUTOFF VALVES AND COUPLINGS REPLACEMENT (M764)**

This task covers:

**a. Removal**

**b. Installation**

**INITIAL SETUP:**

APPLICABLE MODELS

M764

MATERIALS/PARTS

Two drivescrews

Lockwasher

Antiseize tape (Appendix C, Item 27)

REFERENCES (TM)

TM 9-2320-361-10

TM 9-2320-361-20P

EQUIPMENT CONDITION

- Parking brake set (TM 9-2320-361-10).
- Air reservoirs drained (TM 9-2320-361-10).

GENERAL SAFETY INSTRUCTIONS

Do not disconnect air couplings before draining air reservoirs.

**a. Removal**

**WARNING**

Do not disconnect air couplings before draining air reservoirs. Small parts under pressure may shoot out with high velocity, causing injury to personnel.

**NOTE**

The right emergency and left service couplings and cutoff valves are replaced the same. This procedure covers the right side of service brake.

1. Remove dummy coupling (11) from coupling half (10).
2. Remove chain (12) and dummy coupling (11) from frame (4).
3. Remove coupling half (10) from elbow (8).
4. Remove two drivescrews (13) and plate (9) from bracket (14). Discard drivescrews (13).
5. Remove elbow (8) from connector (6).
6. Remove air line (2) and elbow (1) from cutoff valve (15).
7. Remove nut (7), lockwasher (5), and cutoff valve (15) from frame (4). Discard lockwasher (5).
8. Remove connector (6) and nut (3) from cutoff valve (15).

**NOTE**

Wrap all male pipe threads with antiseize tape before installation.

1. Install connector (6) and nut (3) on cutoff valve (15).
2. Install cutoff valve (15) with connector (6) on frame (4) with new lockwasher (5) and nut (7).
3. Install elbow (1) and air line (2) on cutoff valve (15).
4. Install elbow (8) on connector (6).
5. Install plate (9) on bracket (14) with two new drivescrews (13).
6. Install coupling half (10) on elbow (8).
7. Install chain (12) and dummy coupling (11) on frame (4).
8. Install dummy coupling (11) on coupling half (10).
9. Make sure cutoff valve (15) handle is turned to OFF position.

8-32. AIRBRAKE CUTOFF VALVES AND COUPLINGS REPLACEMENT (M764) (Contd)

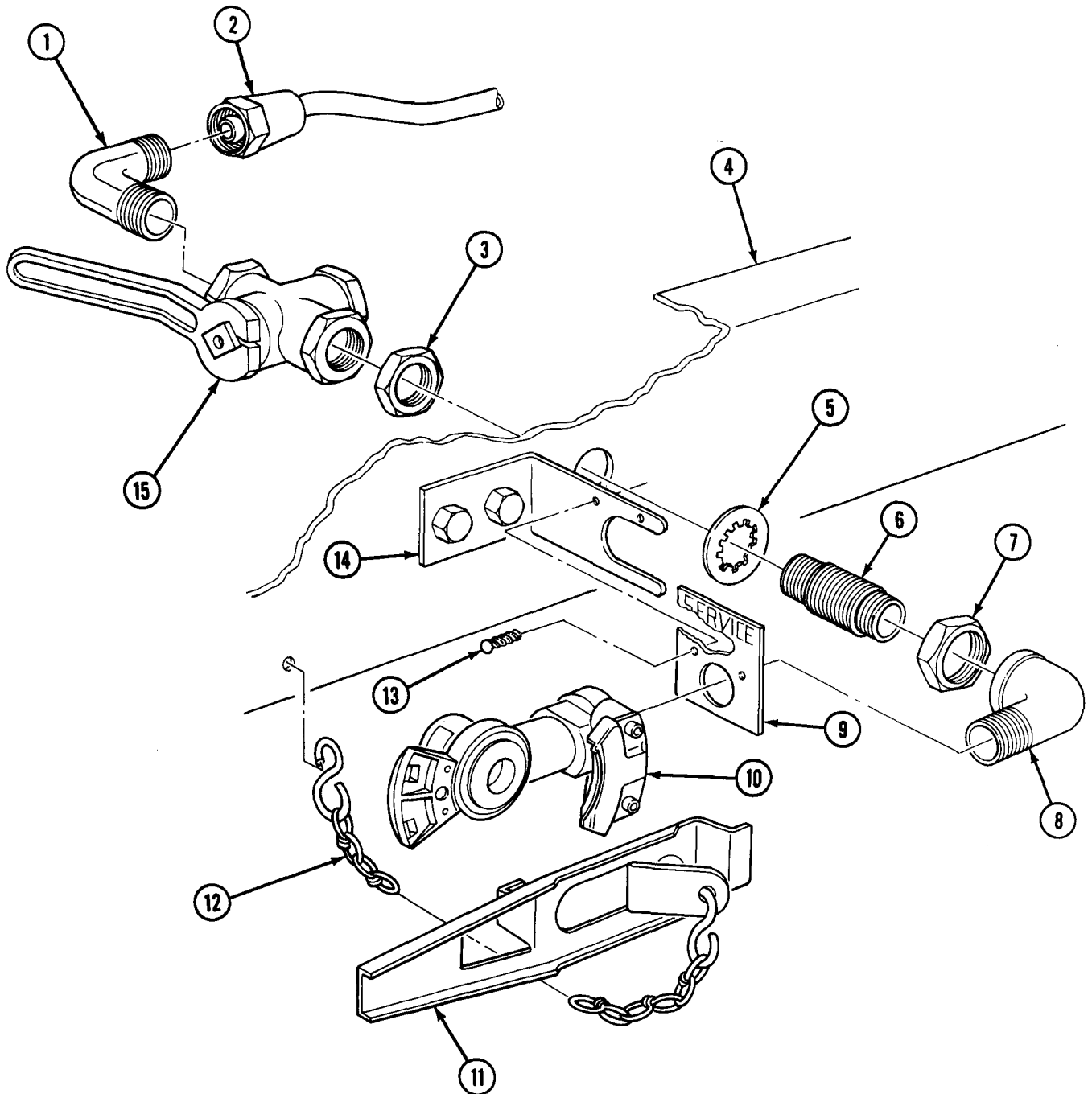

FOLLOW-ON TASK Start engine (TM 9-2320-361-10), build up air pressure, and check for air leaks.

**8-33. AIRBRAKE CUTOFF VALVES AND COUPLINGS REPLACEMENT (M275A2, M342A2)**

This task covers:

**a. Removal**

**b. Installation**

**INITIAL SETUP:**

APPLICABLE MODELS

M275A2, M342A2

MATERIALS/PARTS

Lockwasher

Antiseize tape (Appendix C, Item 27)

REFERENCES (TM)

TM 9-2320-361-10

TM 9-2320-361-20P

EQUIPMENT CONDITION

- Parking brake set (TM 9-2320-361-10).
- Air reservoirs drained (TM 9-2320-361-10).

GENERAL SAFETY INSTRUCTIONS

Do not disconnect air couplings before draining air reservoirs.

**a. Removal**

**WARNING**

Do not disconnect air couplings before draining air reservoirs. Small parts under pressure may shoot out with high velocity, causing injury to personnel.

**NOTE**

The right emergency and left service couplings and cutoff valves are replaced the same. This procedure covers the right side of service brake.

1. Remove dummy coupling (8) from coupling half (9).
2. Remove dummy coupling (8) and chain (11) from bracket (12).
3. Remove coupling half (9) from nipple (10).
4. Remove nipple (10) from cutoff valve (7).
5. Remove air line (2) and elbow (1) from connector (4).
6. Remove nut (13), lockwasher (3), and cutoff valve (7) from frame (12). Discard lockwasher (3).
7. Remove connector (4), nut (5), and elbow (6) from cutoff valve (7).

**b. Installation**

**NOTE**

Wrap all male pipe threads with antiseize tape before installation.

1. Install connector (4), nut (5), and elbow (6) on cutoff valve (7).
2. Install cutoff valve (7) on frame (12) with new lockwasher (3) and nut (13).
3. Install elbow (1) and air line (2) on connector (4).
4. Install nipple (10) on cutoff valve (7).
5. Install coupling half (9) on nipple (10).
6. Install chain (11) and dummy (8) on coupling half (9).
7. Install dummy coupling (8) on coupling half (9).
8. Make sure cutoff valve (7) handle is in OFF position.

8-33. AIRBRAKE CUTOFF VALVES AND COUPLINGS REPLACEMENT (M275A2, M342A2)  
(Contd)

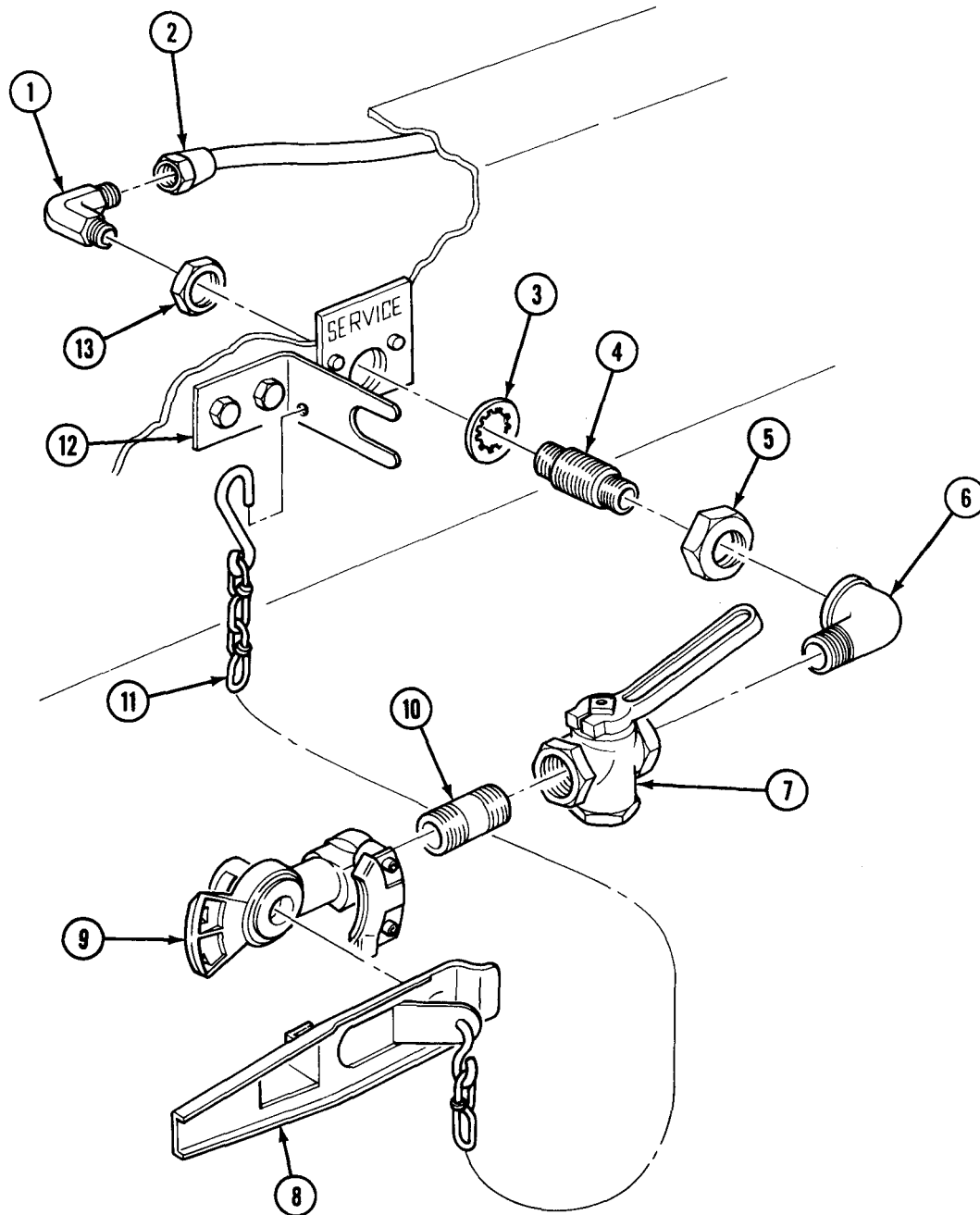

FOLLOW-ON TASK: Start engine (TM 9-2320-361-10), build up air pressure, and check for air leaks.

**8-34. AIRBRAKE HOSE REPLACEMENT**

This task covers:

**a. Removal**

**b. Installation**

**INITIAL SETUP:**

APPLICABLE MODELS

M275A2

MATERIALS/PARTS

Antiseize tape (Appendix C, Item 27)

REFERENCES (TM)

TM 9-2320-361-10

TM 9-2320-361-20P

EQUIPMENT CONDITION

- Parking brake set (TM 9-2320-361-10).
- Air reservoirs drained (TM 9-2320-361-10).

GENERAL SAFETY INSTRUCTIONS

Do not disconnect air lines before draining air reservoirs.

**NOTE**

The right emergency and left service airbrake hoses are replaced the same. This procedure covers the left side of service brake.

**a. Removal**

**WARNING**

Do not disconnect air couplings before draining air reservoirs. Small parts under pressure may shoot out with high velocity, causing injury to personnel.

1. Remove hose (3) from adapter (5) and ring (4).
2. Remove coupling (1) from adapter (2).
3. Remove adapter (2) from hose (3).

**NOTE**

Wrap all male pipe threads with antiseize tape before installation.

1. Install adapter (2) on hose (3).
2. Install coupling (1) on adapter (2).
3. Install hose (3) on ring (4) and adapter (5).

8-34. AIRBRAKE HOSE REPLACEMENT (Contd)

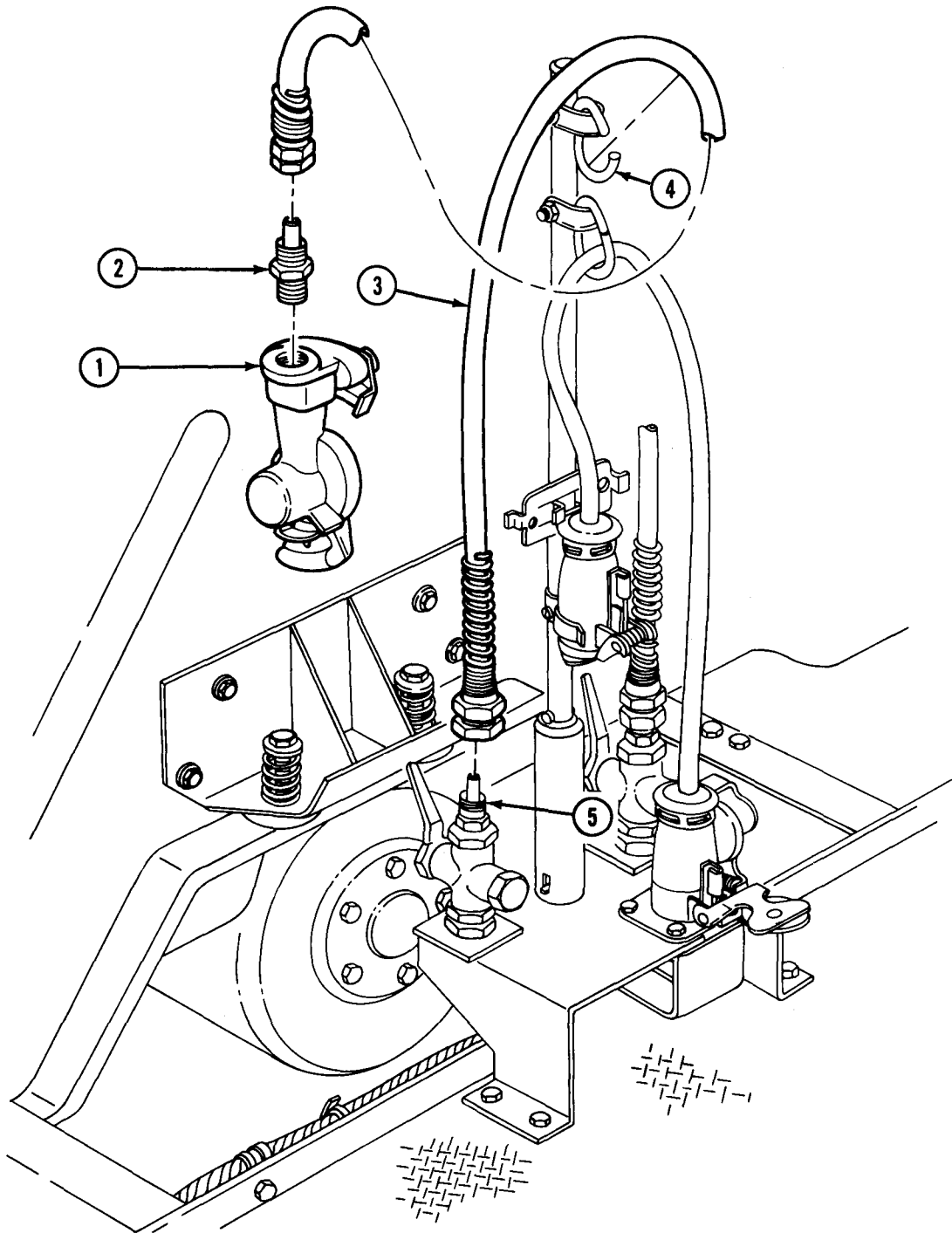

FOLLOW-ON TASK: Start engine (TM 9-2320-361-10), build up air pressure, and check for air leaks.



**8-35. SHUTTLE (DOUBLE CHECK) VALVE REPLACEMENT**

This task covers:

**a. Removal**

**b. Installation**

**INITIAL SETUP:**

APPLICABLE MODELS

M275A2

MATERIALS/PARTS

Locknut

Antiseize tape (Appendix C, Item 27)

REFERENCES (TM)

TM 9-2320-361-10

TM 9-2320-361-20P

EQUIPMENT CONDITION

- Parking brake set (TM 9-2320-361-10).
- Air reservoirs drained (TM 9-2320-361-10).

GENERAL SAFETY INSTRUCTIONS

Do not disconnect air lines before draining air reservoirs.

**a. Removal**

**WARNING**

Do not disconnect air lines before draining air reservoirs. Small parts under pressure may shoot out with high velocity, causing injury to personnel.

**NOTE**

Tag all air lines and hoses for installation.

1. Remove two connectors (8) from switch (9).
2. Remove air line (2) from elbow (1).
3. Remove air line (5) from adapter (6).
4. Remove air line (13) from adapter (12).
5. Remove locknut (3), screw (11), and shuttle valve (7) from crossmember (4). Discard locknut (3).

**NOTE**

Mark fittings for installation.

6. Remove elbow (1) and two adapters (6) and (12) from shuttle valve (7).
7. Remove switch (9) and adapter (10) from shuttle valve (7).

**NOTE**

- Use old fittings and switch when installing new shuttle valve.
- Wrap all male pipe threads with anti seize tape before installation.

1. Install adapter (10) and switch (9) on shuttle valve (7).
2. Install two adapters (12) and (6) and elbow (1) on shuttle valve (7).
3. Install shuttle valve (7) on crossmember (4) with screw (11) and new locknut (3).
4. Install air line (13) on adapter (12).
5. Install air line (5) on adapter (6).

**8-35. SHUTTLE (DOUBLE CHECK) VALVE REPLACEMENT (Contd)**

6. Install air line (2) on elbow (1).
7. Install two connectors (8) on switch (9).

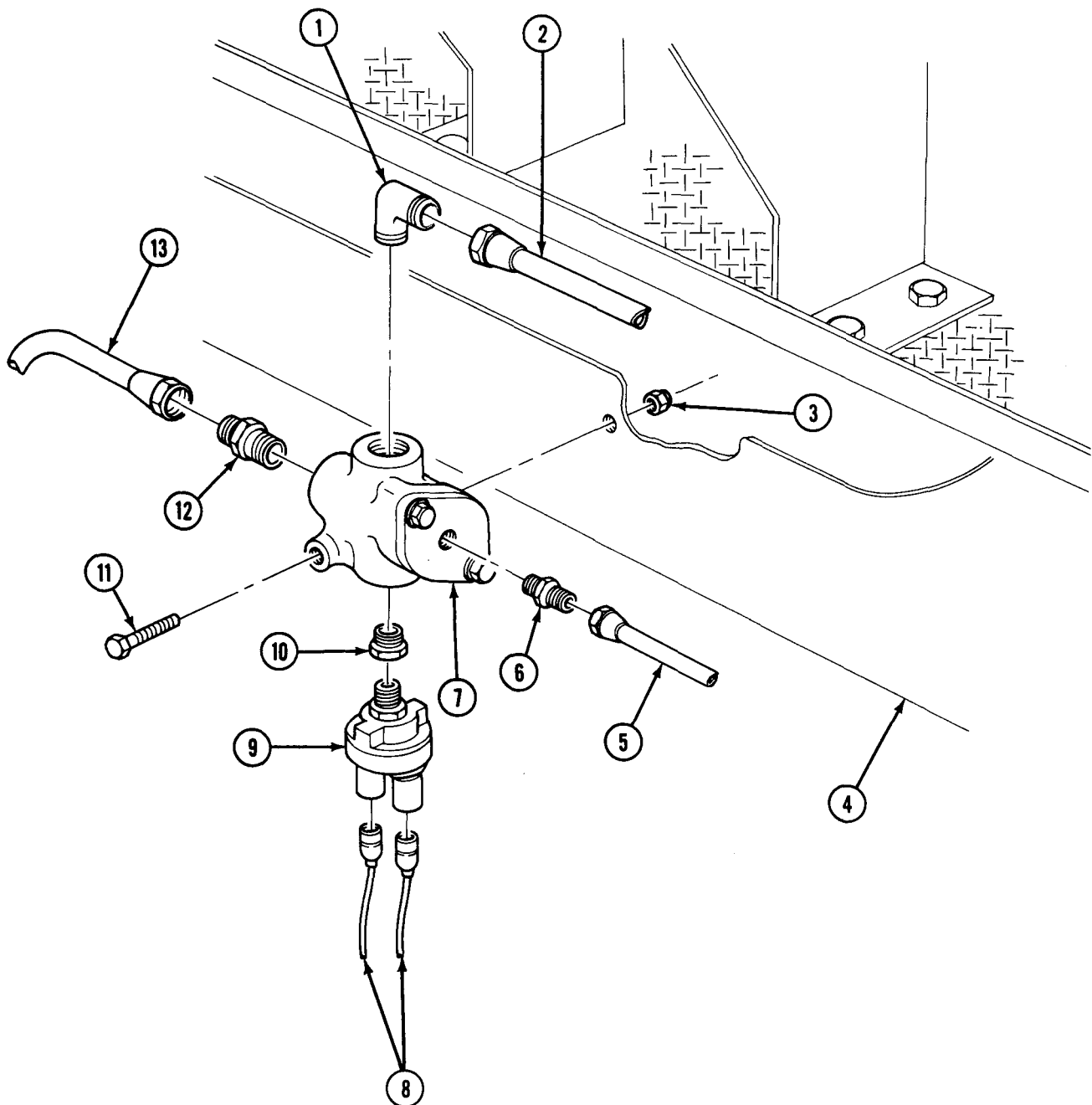

FOLLOW-ON TASK: Start engine (TM 9-2320-361-10), build up air pressure, and check for leaks.

## 8-36. TRAILER PROTECTION VALVE REPLACEMENT

This task covers:

**a. Removal**

**b. Installation**

INITIAL SETUP:

APPLICABLE MODELS

M275A2

MATERIALS/PARTS

Two locknuts

Antiseize tape (Appendix C, Item 27)

REFERENCES [TM]

TM 9-2320-361-10

TM 9-2320-361-20P

EQUIPMENT CONDITION

- Parking brake set (TM 9-2320-361-10).
- Air reservoirs drained (TM 9-2320-361-10).

GENERAL SAFETY INSTRUCTIONS

Do not disconnect air lines before draining air reservoirs.

### a. Removal

#### WARNING

Do not disconnect air lines before draining air reservoirs. Small parts under pressure may shoot out with high velocity, causing injury to personnel.

#### **NOTE**

Tag air lines and hoses for installation.

1. Remove service trailer brake line (1) from elbow (2).
2. Remove emergency trailer brake line (6) from elbow (3).
3. Remove brake signal air line (11) from elbow (10).
4. Remove air reservoir air line (8) from elbow (9).
5. Remove two locknuts (4), screws (12), and trailer protection valve (7) from bracket (5). Discard locknuts (4).
6. Remove four elbows (2), (3), (9), and (10) from trailer protection valve (7).

#### **NOTE**

Wrap all male pipe threads with antiseize tape before installation.

1. Install four elbows (10), (9), (3), and (2) on trailer protection valve (7).
2. Install trailer protection valve (7) on bracket (5) with two screws (12) and new locknuts (4).
3. Install air reservoir air line (8) on elbow (9).
4. Install brake signal air line (11) on elbow (10).
5. Install emergency trailer brake line (6) on elbow (3).
6. Install service trailer brake line (1) on elbow (2).

8-36. TRAILER PROTECTION VALVE REPLACEMENT (Contd)

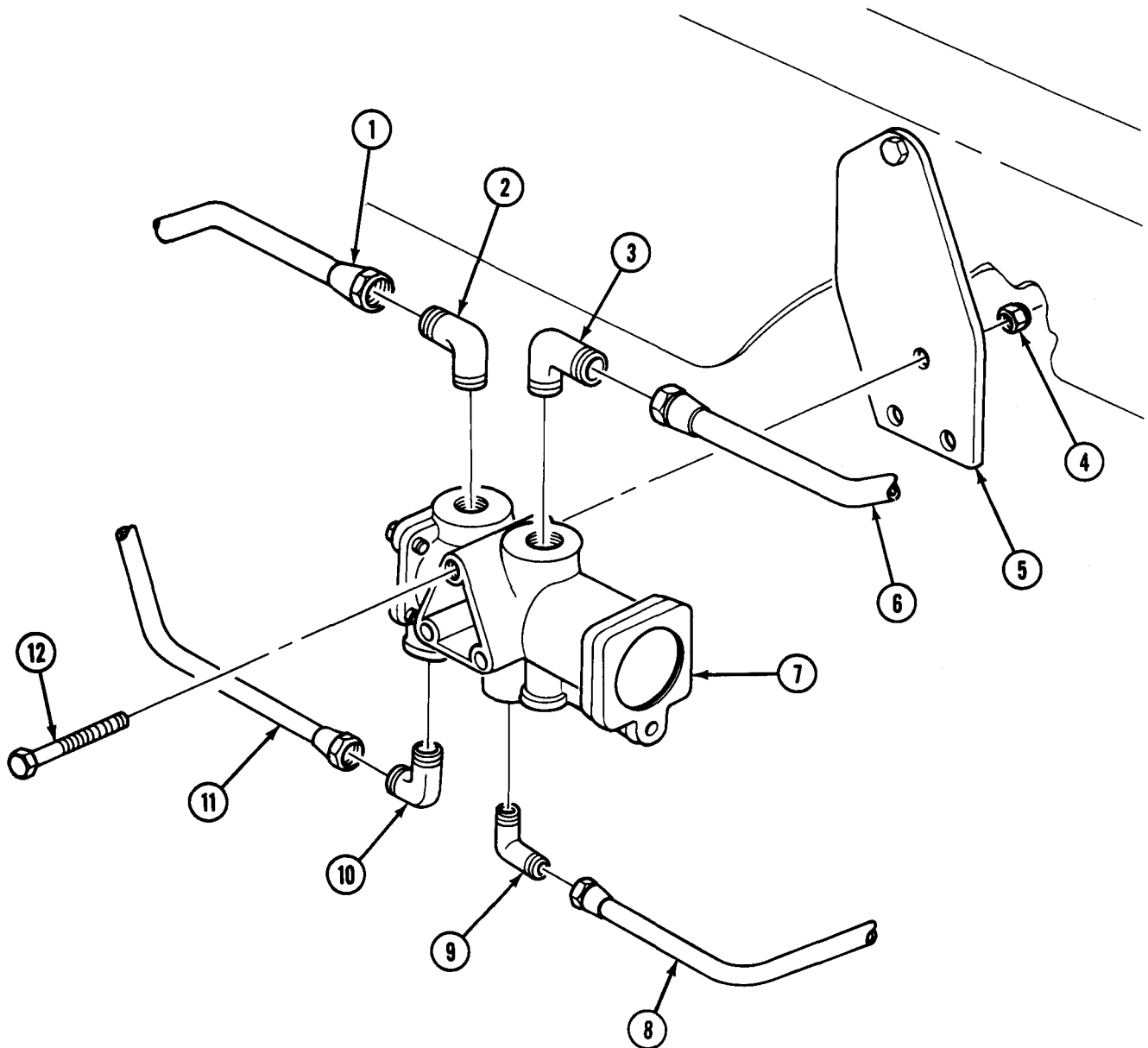

FOLLOW-ON TASK: Start engine (TM 9-2320-361-10), build up air pressure, and check for air leaks.

## 8-37. TRAILER BRAKE HOSE MAST REPLACEMENT

This task covers:

**a. Removal**

**b. Installation**

**INITIAL SETUP:**

APPLICABLE MODELS

M275A2

REFERENCES (TM)

TM 9-2320-361-10

TM 9-2320-361-20P

MATERIALS/PARTS

Lockwasher

EQUIPMENT CONDITION

Parking brake set (TM 9-2320-361-10).

**a. Removal**

1. Remove two air hoses (1) and (5) from ring (3) and holder (6), and electrical cable (8) from ring (2) and clip (7).
2. Remove nut (12), lockwasher (11), and washer (10) from screw (9). Discard lockwasher (11).
3. Remove mast (4) from base (13).

**b. Installation**

1. Install mast (4) on base (13) with washer (10), new lockwasher (11), and nut (12) on screw (9).
2. Install electrical cable (8) on clip (7) and ring (2), and hoses (5) and (1) on holder (6) and ring (3).

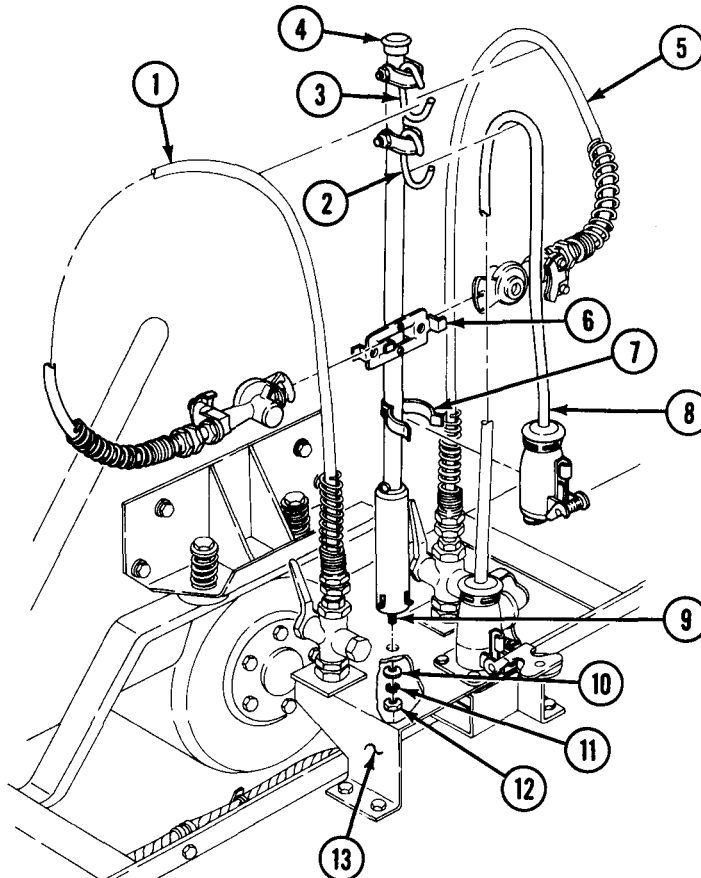

## CHAPTER 9 WHEEL, HUB, DRUM, AND STEERING SYSTEM MAINTENANCE

Section I. Wheel, Hub, and Drum Maintenance (page 9-1)  
Section II. Steering System Maintenance (page 9-12)

### Section I. WHEEL, HUB, AND DRUM MAINTENANCE

**9-1. WHEEL, HUB, AND DRUM MAINTENANCE INDEX**

PARA. NO.	TITLE	PAGE NO.
9-2.	Wheel, Tire, and Tube Maintenance	9-1
9-3.	Front Hub and Drum Maintenance	9-6
9-4.	Rear Hub and Drum Maintenance	9-8
9-5.	Wheel Bearing Adjustment	9-11

**9-2. WHEEL, TIRE, AND TUBE MAINTENANCE**

This task covers:

- |   |  |
|---|--|
| <ul style="list-style-type: none"> <li>a. Wheel Removal</li> <li>b. Tire and Tube Removal</li> <li>c. Inspection</li> </ul> | <ul style="list-style-type: none"> <li>d. Tire and Tube Installation</li> <li>e. Wheel Installation</li> </ul> |
|---|--|

**INITIAL SETUP:**

APPLICABLE MODELS

All

SPECIAL TOOLS

Wrench, socket P/N 7083293

MATERIALS/PARTS

Six capnuts

PERSONNEL REQUIRED

Two

REFERENCES (TM)

TM 9-2320-361-10  
TM 9-2320-361-20P  
TM 9-2610-200-24

EQUIPMENT CONDITION

- Parking brake set (TM 9-2320-361-10).
- Wheels chocked (TM 9-2320-361-10).

GENERAL SAFETY INSTRUCTIONS

- Never remove tire lockring without first deflating tire.
- Never inflate tire with lockring facing personnel.
- Always use tire inflation cage.
- Never attempt to seat lockring by striking while tire is inflated.
- Always use tire inflation equipment specified in TM 9-2610-200-24. Warn personnel to stand clear of inflation cage.
- Completely deflate tires before removing from axles if there is obvious damage to wheel components.

**a. Wheel Removal**

**WARNING**

Completely deflate tires before removing from axles if there is obvious damage to wheel components. Injury or death to personnel may result from exploding wheel components.

**NOTE**

- Wheel stud nuts on left side have left-hand threads and must be turned to the right to loosen them. Wheel stud nuts on right side have right-hand threads and must be turned to the left to loosen them. Studs and nuts are stamped (L) left and (R) right.
- Rear and front wheels are maintenance in the same way. This procedure covers rear wheels.

**9-2. WHEEL, TIRE, AND TUBE MAINTENANCE (Contd)**

1. Loosen six wheel stud nuts (1) on wheel (2) to be removed.
2. Raise vehicle with hydraulic jack (7) and place jack stand (8) under axle (6) of wheel (2) to be removed.
3. Remove six wheel stud nuts (1) from inner-rear wheel (4).

**CAUTION**

Do not slide wheel on threaded studs. Sliding wheel may damage threads.

**NOTE**

Assistant will help with steps 4 and 5.

4. Remove outer-rear wheel (2) from hub (5).

**NOTE**

To remove inner wheel, reverse wheel stud nut wrench, remove handle, and install near large end of wrench.

5. Remove six wheel capnuts (3) and inner-rear wheel (4) from hub (5). Discard capnuts (3).

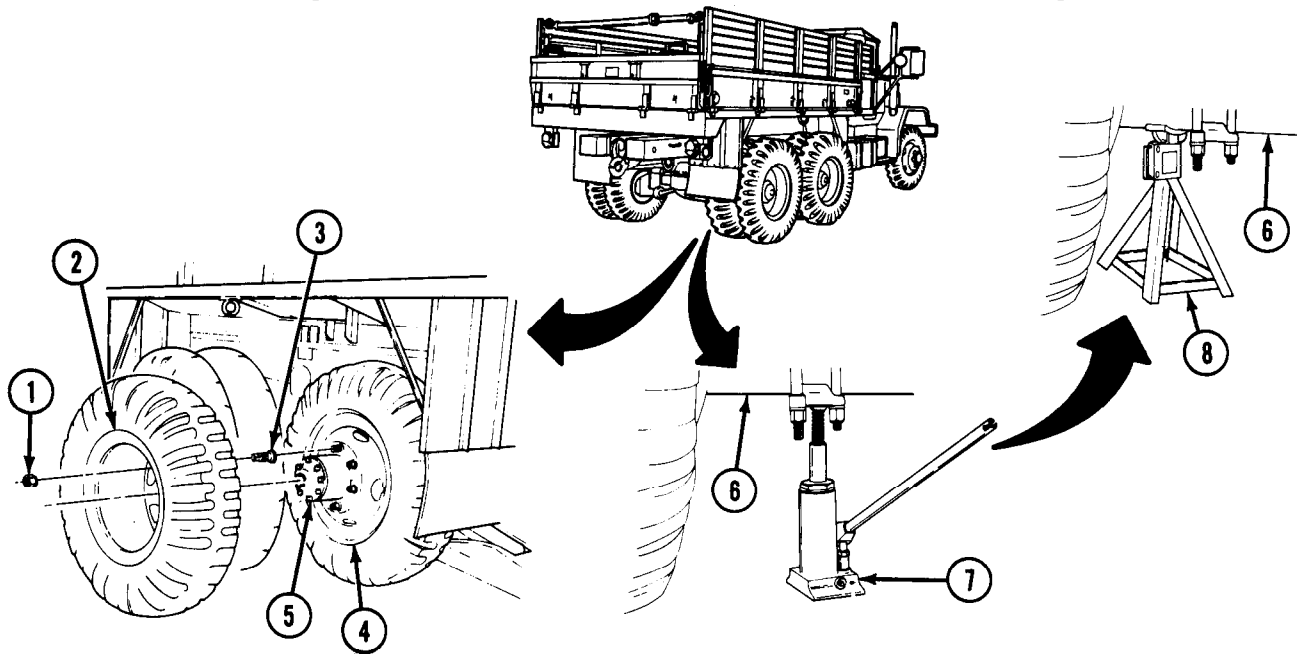

**b. Tire and Tube Removal**

1. Unscrew valve cap (10) from valve stem (9) and use valve cap (10) to remove valve core (11) from valve stem (9) to release air from tire.

**WARNING**

Never remove tire lockring without first deflating tire. Lockring may explode off, causing injury or death to personnel.

**NOTE**

Put a soap and water solution on tire bead to help remove tire from rim.

9-2. WHEEL, TIRE, AND TUBE MAINTENANCE (Contd)

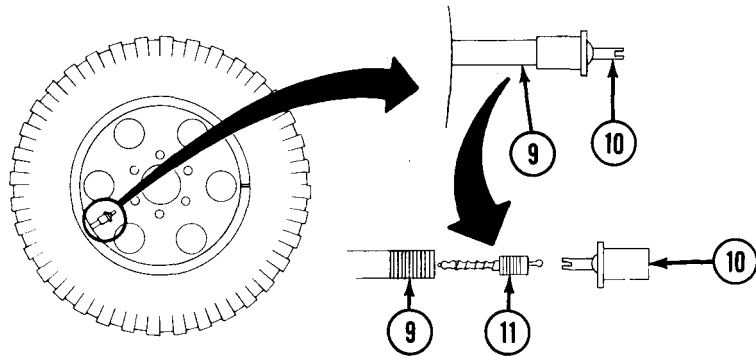

2. Lay outer-rear wheel (2) flat on side with locking (12) facing upwards and break tire bead (21) from locking (12).

**NOTE**

Assistant will help with step 3.

3. Insert first tire iron (14) between locking slit (13) and pry upward until locking slot (15) is exposed.
4. Insert second tire iron (16) in locking slot (15) and pry outward and upward.
5. Run first tire iron (14) completely around and remove locking (12).

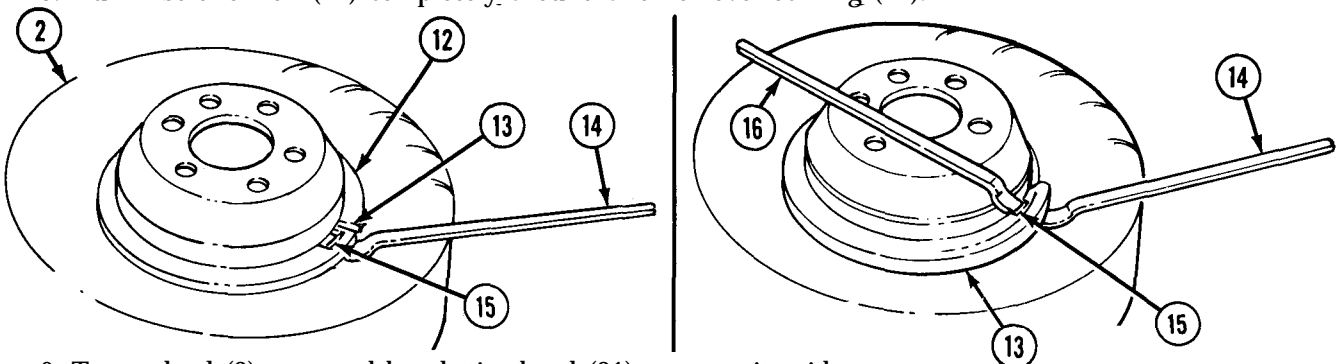

6. Turn wheel (2) over and break tire bead (21) on opposite side.
7. Remove rim (17), tire liner (20), and tube (19) from tire (18).

1. Inspect rim (17) and locking ring (12) for bends, cracks, breaks, distortion, or pitting from corrosion. Replace if bent, cracked, broken, distorted, or pitted from corrosion.
2. Inspect tire (18), tube (19), and tire liner (20) for cracks, stud hole damage, and bends. Replace if cracked, stud holes are damaged, or bent.

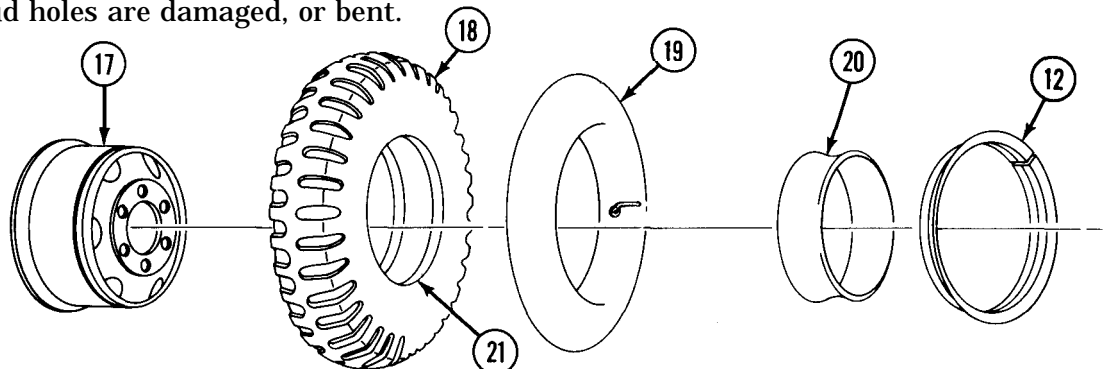



## 9-2. WHEEL, TIRE, AND TUBE MAINTENANCE (Contd)

### d. Tire and Tube Installation

1. Use valve cap (8) to screw valve core (7) into valve stem (4), and place tube (3) in tire (2).
2. Inflate tube (3) enough to hold shape [do not exceed 3 psi (21 kPa)], and install tire liner (5) over valve stem (4). Ensure tube (3) and tire liner (5) are straight and not pinched.
3. Install tire (2) and tube (3) on rim (1) and guide valve stem (4) through hole in rim (1), and seat tire (2) firmly.

#### **WARNING**

- Lockring must be properly seated around wheel when installed. If lockring is not correctly installed, it may explode off when tire is inflated, causing injury or death to personnel.
  - Never attempt to correct seating of lockring by hammering, striking, or forcing while tire is inflated. Lockring may explode off, causing injury or death to personnel.
4. Install lockring (6) into groove of rim (1).

#### **WARNING**

- Never inflate a tire without a tire inflation cage. Injury or death to personnel may result from exploding wheel components.
- Always use tire inflation equipment specified in TM 9-2610-200-24. Warn personnel to stand 10 ft (3.1 m) clear of tire inflation cage while inflating tire. Injury or death may result from exploding wheel components.
- Never rest or lean against tire inflation cage while tire is being inflated or injury or death to personnel may result.

#### **NOTE**

Ensure tire inflation cage does not have cracked welds, cracked or bent components, or pitting from corrosion. If any of these are found, obtain new cage.

5. Inflate tire (2) (TM 9-2320-361-10) and install valve cap (8).
6. Inspect rim (1) and lockring (6) for proper seating while still in inflation cage. If further adjustment is required, deflate tire (2) completely before adjusting lockring (6).

## 9-2. WHEEL, TIRE, AND TUBE MAINTENANCE (Contd)

### e. Wheel Installation

#### **CAUTION**

When installing stud nuts, ensure to put the curved (ball seat) surface of the nut toward the wheel to seat properly. Failure to do this may result in damage to wheel.

#### **NOTE**

- Wear of rear dual tires should be matched as closely as possible. Valves on rear tires must be opposite each other (180° apart). Ventilation holes in outer wheel should be directly aligned with ventilation holes in inner wheel.
- Nuts have left-hand threads on left wheel assembly and right-hand threads on right wheel assembly. Studs and nuts are stamped (L) left and (R) right.
- Assistant will help steps 1 and 3.
- If inner-rear wheel is being replaced, ensure inner stud nuts are properly seated when installed.
- If inner-rear wheel is being installed, perform step 4. If outer-rear wheel or front wheel is being installed, go to step 5.

1. Lift inner wheel (13) and install on wheel studs (12).
2. Install and hand tighten six new wheel capnuts (11) on wheel studs (12).
3. Lift wheel (10) and install on wheel capnuts (11) with six stud nuts (9). On front wheel, ensure brake inspection plate (14) is visible through ventilation hole.
4. Tighten six wheel capnuts (11) 400-425 lb-ft (542-576 Nǃm) in tightening sequence shown.
5. Raise vehicle with hydraulic jack, remove jack stand (15), and lower vehicle to ground.
6. Tighten six stud nuts (9) on front wheel 325-355 lb-ft (441-481 Nǃm) and six stud nuts (9) on wheel (10) 325-355 lb-ft (441-481 Nǃm) in sequence shown.

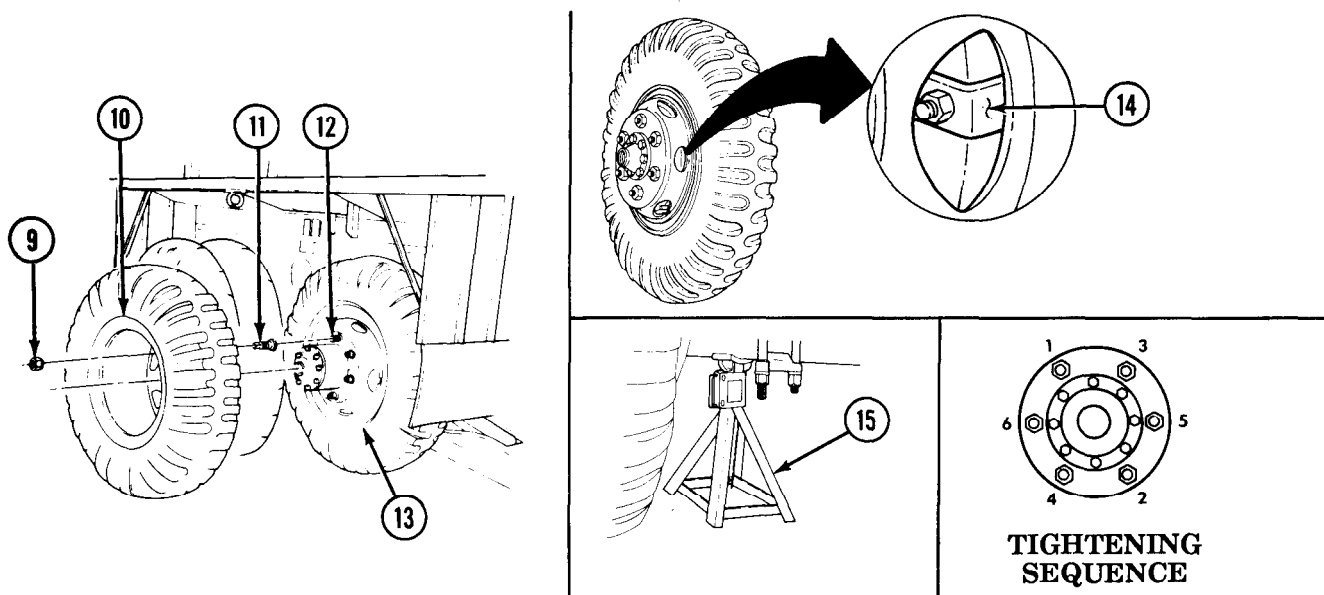

---

**9-3. FRONT HUB AND DRUM MAINTENANCE**

---

This task covers:

- |  |   |
|--|---|
| <p><b>a. Removal</b><br/><b>b. Cleaning and Inspection</b></p> | <p><b>c. Lubrication</b><br/><b>d. Installation</b></p> |
|--|---|
- 

**INITIAL SETUP**

**APPLICABLE MODELS**

All

**MATERIALS/PARTS**

Ten lockwashers  
Six wheel studs  
Ten screws  
Inner bearing seal  
GAA grease (Appendix C, Item 13)

**PERSONNEL REQUIRED**

Two

**REFERENCES (TM)**

TM 9-2320-361-10  
TM 9-2320-361-20P  
TM 9-214

**EQUIPMENT CONDITION**

- Front wheel (s) removed (para. 9-2) and rear wheels chocked (TM 9-2320-361-10)
- Front axle shaft flange removed (para. 7-10).

**GENERAL SAFETY INSTRUCTIONS**

Keep fire extinguisher nearby when using drycleaning solvent.

---

**a. Removal**

1. Bend back tabs on adjusting nut washer (13) and remove outer adjusting nut (14), adjusting nut washer (13), and inner adjusting nut (12) from spindle (8).
2. Pull hub (2) and drum (10) with outer bearing (11) out about one inch. Push hub (2) and drum (10) back, and remove outer bearing (11).

**CAUTION**

Do not slide hub and drum assembly over-threaded end of spindle, or damage to equipment may result.

3. Remove hub (2) and drum (10) from spindle (8).
4. Remove ten nuts (15), lockwashers (16), and inspection cover (17). Discard lockwashers (16).
5. Remove six wheel studs (9) from adapter (4) and hub (2). Discard studs (9).
6. Remove ten screws (5) from adapter (4) and drum (10). Discard screws (5).
7. Remove inner bearing (6) and seal (7) from spindle (8). Discard seal (7).

**b. Cleaning and Inspection**

**WARNING**

Drycleaning solvent is flammable and will not be used near open flame. Use only in well-ventilated places. Failure to do so may result in injury to personnel.

1. Clean all hub (2) and drum (10) components with drycleaning solvent, and allow to air dry. Do not use compressed air to dry bearings (6) or (11).
2. Inspect inner and outer bearings (6) and (11) (TM 9-214). If damaged, replace,
3. Inspect inner and outer bearing cups (1) and (3) (TM 9-214). If damaged, replace.

**NOTE**

Perform steps 4 and 5 only if bearings or bearing cups are to be replaced.

4. Remove inner and outer bearing cups (1) and (3) from hub (2) by tapping alternately on outer edge.
5. Press new inner and outer bearing cups (1) and (3) into hub (2). Ensure cups (1) and (3) are seated.

### 9-3. FRONT HUB AND DRUM MAINTENANCE (Contd)

6. Inspect hub (2) for cracks and breaks. Replace if cracked or broken.
7. Inspect drum (10) for deep grooves and cracks. Replace if broken. If grooved or scored, notify supervisor.
8. Check adapter (4) for cracks or warps. Replace if cracked or warped.

#### c. Lubrication

1. Pack inner and outer bearings (6) and (11) with GAA grease (TM 9-214).
2. Apply light coat of GAA grease to rubber section of new inner bearing seal (7).

#### d. Installation

1. Install seal (7) and inner bearing (6) on spindle (8).
2. Install adapter (4) on drum (10) with ten new screws (5).
3. Position hub (2) on adapter (4), align inspection holes of hub (2) and drum (10), and install with six new wheel studs (9).
4. Install inspection cover (17) (placed to cover inspection hole), ten new lockwashers (16), and nuts (15) on new screws (5). Tighten nuts (15) 31-39 lb-ft (42-53 N·m).

#### CAUTION

Do not slide hub and drum assembly over threaded end of spindle, or damage to equipment may result.

5. Install hub (2) and drum (10) on spindle (8).
6. Install outer bearing (11) in hub (2) and drum (10).
7. Check brake adjustment (para. 8-8).
8. Install inner adjusting nut (12) and front wheel on spindle (8).
9. Adjust outer bearing (11) (para. 9-5) and install adjusting nut washer (13) and outer adjusting nut (14) on spindle (8). Bend tabs of adjusting nut washer (13) down,

FOLLOW-ON TASK Install front axle shaft flange (para. 7-10).

**9-4 REAR HUB AND DRUM MAINTENANCE**

This task covers:

- |                                   |                        |
|-----------------------------------|------------------------|
| <b>a. Removal</b>                 | <b>c. Lubrication</b>  |
| <b>b. Cleaning and Inspection</b> | <b>d. Installation</b> |

**INITIAL SETUP:**

APPLICABLE MODELS

All

MATERIALS/PARTS

- Outer bearing seal
- Inner bearing seal
- Cork gasket
- Eighteen lockwashers
- Six wheel studs
- Ten screws
- Ten locknuts
- Seal
- Safety wire (Appendix C, Item 22)
- GAA grease (Appendix C, Item 13)

PERSONNEL REQUIRED

Two

REFERENCES (TM)

- TM 9-2320-361-10
- TM 9-2320-361-20P
- TM 9-214

EQUIPMENT CONDITION

- Wheels chocked (TM 9-2320-361-10).
- Rear wheel(s) removed (para. 9-2)
- Rear axle shaft flange removed (para. 7-11).

GENERAL SAFETY INSTRUCTIONS

Keep fire extinguisher nearby when using drycleaning solvent.

**a. Removal**

1. Bend back tabs on adjusting nut washer (22), and remove outer adjusting nut (23), adjusting nut washer (22), and inner adjusting nut (21) from spindle (8).

**CAUTION**

Do not slide seal over threaded end of spindle, or damage to seal may result.

2. Remove outer seal (20), cork gasket (14), and outer bearing (19) from spindle (8). Discard cork gasket (14) and outer seal (20).

**CAUTION**

Do not slide hub and drum assembly over spindle, or damage to equipment may result.

3. Remove hub (13) and drum (18) from spindle (8).
4. Remove ten locknuts (15), lockwashers (16), and inspection cover (17) from drum (18). Discard locknuts (15) and lockwashers (16).
5. Remove ten screws (3) and deflector (2) from adapter (1). Discard screws (3).
6. Remove hub (13) from drum (18).
7. Remove safety wire (9), eight screws (10), lockwashers (11), and adapter (1) from hub (13). Discard safety wire (9) and lockwashers (11).
8. Remove six wheel studs (12) from hub (13). Discard studs (12).
9. Remove inner bearing (4) and seal (5) from spindle (8). Discard seal (5).

**b. Cleaning and Inspection**

**WARNING**

Drycleaning solvent is flammable and will not be used near open flame. Use only in well-ventilated places. Failure to do so may result in injury or death to personnel.

1. Clean all hub (13) and drum (18) components with drycleaning solvent, and allow to air dry. Do not use compressed air to dry bearings (4) or (19).

9-4. REAR HUB AND DRUM MAINTENANCE (Contd)

**NOTE**

Perform steps 5 and 6 only if bearings or bearing cups are to be replaced.

2. Inspect inner and outer bearings (4) and (19) (TM 9-214). If damaged, replace.
3. Inspect inner and outer bearing cups (25) and (24) (TM 9-214). If damaged, replace.
4. Check rivets (7) and backing plate (6) for looseness. If loose, notify supervisor.
5. Remove inner and outer bearing cups (25) and (24) from hub (13) by tapping alternately on outer edge.
6. Press new inner and outer bearing cups (25) and (24) into hub (13). Make sure cups (25) and (24) are seated.
7. Inspect hub (13) for cracks or breaks. If cracked or broken, replace.
8. Inspect drum (18) for deep grooves and cracks. If cracked, replace. If grooved or scored, notify your supervisor.
9. Inspect adapter (1) and deflector (2) for cracks or warps. If cracked or warped, replace.

1. Pack inner and outer bearings (4) and (19) with GAA grease (TM 9-214).
2. Apply light coat of GAA grease to rubber section of new inner bearing seal (5).

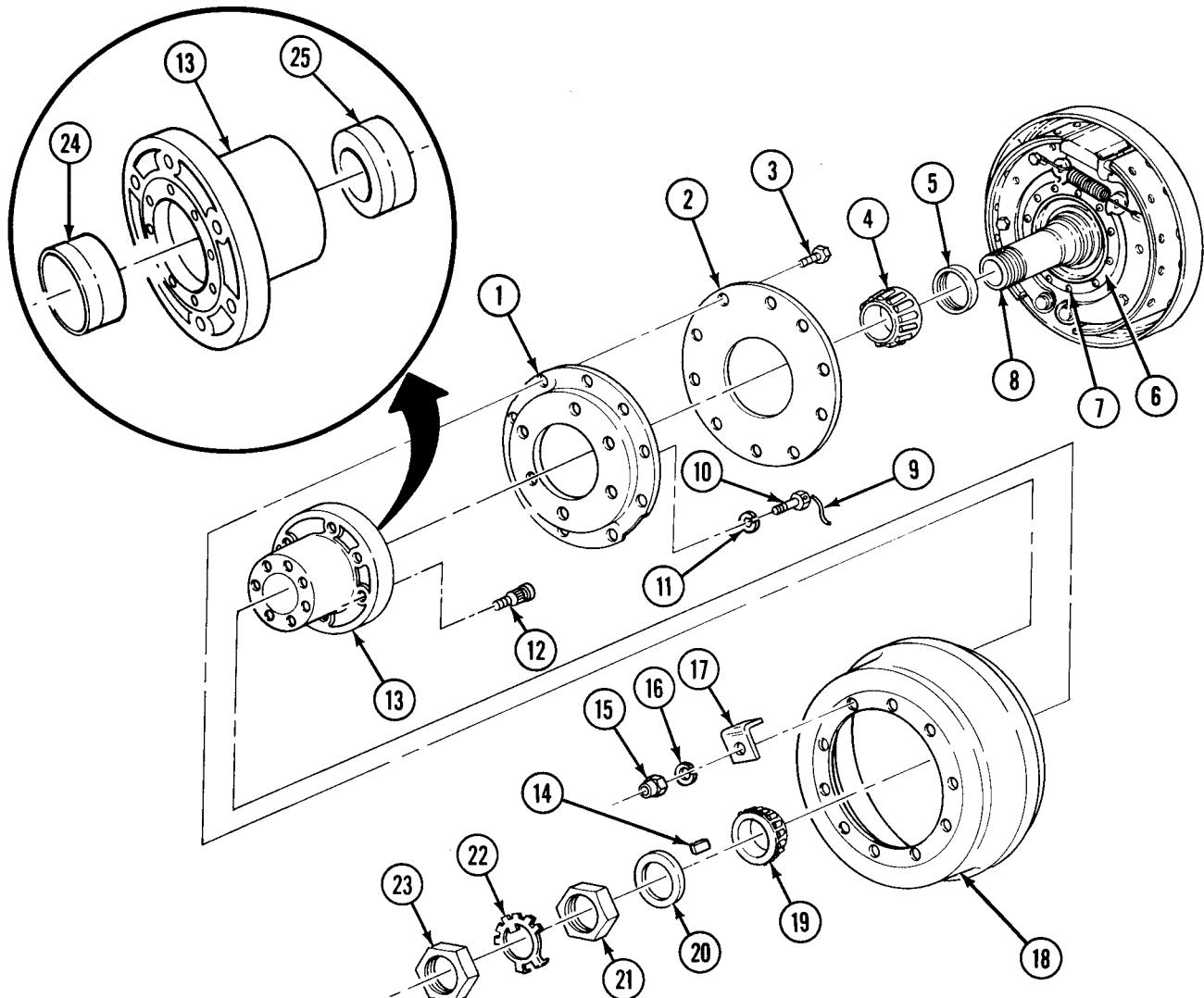

**9-4. REAR HUB AND DRUM MAINTENANCE (Contd)**

**d. Installation**

1. Install new inner bearing seal (5) and inner bearing (4) on spindle (6).
2. Install six new wheel studs (10) on hub (11).
3. Install adapter (1) on hub (11) with eight new lockwashers (9) and screws (8). Tighten screws (8) 81-104 lb-ft (110-141 NŹm) and install new safety wire (7).
4. Install hub (11) in drum (16).
5. Install deflector (2) on adapter (1) with ten new bolts (3).
6. Install inspection cover (15), ten new lockwashers (14), and new locknuts (13). Tighten locknuts (13) 31-39 lb-ft (42-53 NŹm).

**CAUTION**

Do not slide hub and drum assembly over threaded end of spindle, or damage to equipment may result.

7. Install hub (11) and drum (16) on spindle (6).

**CAUTION**

Do not slide seal over threaded end of spindle, or damage to seal may result.

8. Install outer bearing (17) and new cork gasket (12) in keyway of spindle (6), and install new outer seal (18) on spindle (6).
9. Install inner adjusting nut (19) on spindle (6), and adjust wheel bearings (para. 9-5).
10. Install rear wheels (TM 9-2320-361-10), but do not lower.

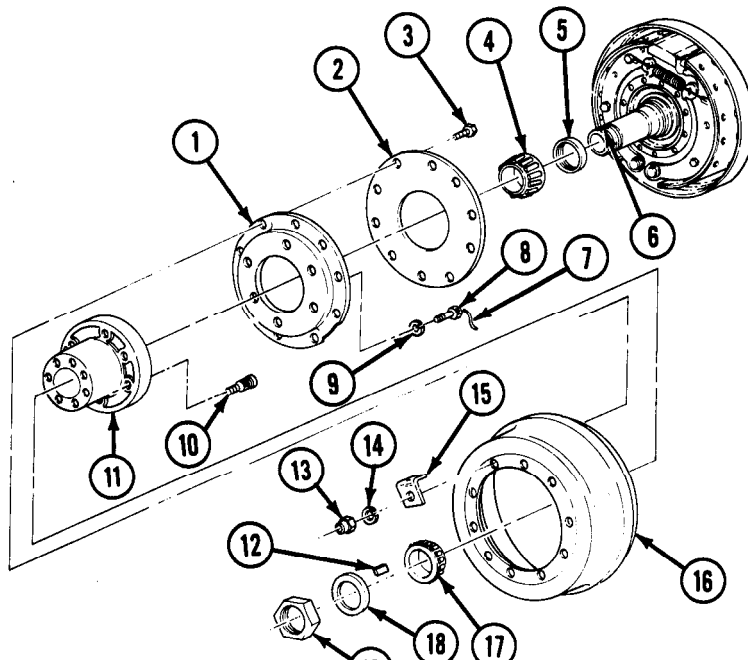

**FOLLOW-ON TASKS:** Install rear axle shaft flange (para. 7-10).  
 • Check brake adjustment (para. 8-8).

## 9-5. WHEEL BEARING ADJUSTMENT

This task covers:

### Wheel Bearing Adjustment

#### INITIAL SETUP:

##### APPLICABLE MODELS

All

##### REFERENCES (TM)

TM 9-2320-361-10

TM 9-2320-361-20P

##### EQUIPMENT CONDITION

- Wheels chocked (TM 9-2320-361-10).
- Front axle shaft flange removed (para. 7-10).
- Rear axle shaft removed (para. 7-11).

### Wheel Bearing Adjustment

#### NOTE

- Wheel must turn freely prior to wheel bearing adjustment.
  - Adjustment procedures for front and rear wheel bearings are the same.
1. Bend tabs back on adjusting nut washer (2) and remove outer adjusting nut (1) and washer (2).
  2. Turn wheel, tighten inner adjusting nut (3) 50 lb-ft (68 NŹm), then back off nut (3) 1/16 to 1/4 turn.
  3. Install adjusting nut washer (2) and outer adjusting nut (1). Tighten nut (1) 100-200 lb-ft (136-272 NŹm).
  4. Bend tabs on adjusting nut washer (2) down, over inner and outer adjusting nuts (3) and (1).

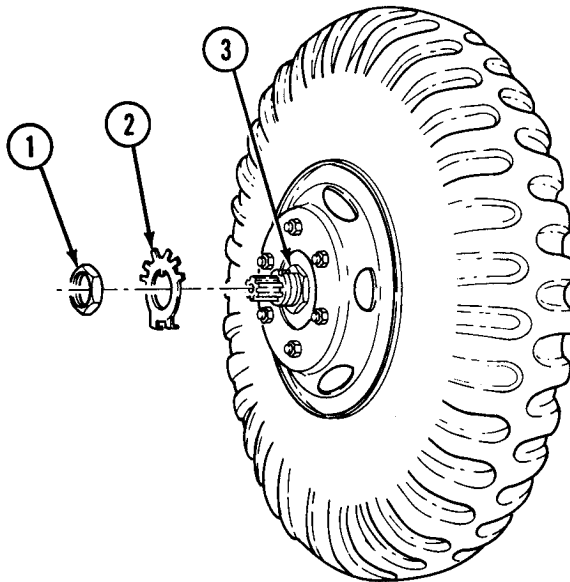

- FOLLOW-ON TASKS:
- Install rear axle shaft (para. 7-11).
  - Install front axle shaft flange (para. 7-10).
  - Adjust service brake (para. 8-8).



Section II. STEERING SYSTEM MAINTENANCE

**9-6. STEERING SYSTEM MAINTENANCE INDEX**

PARA. NO.	TITLE	PAGE NO.
9-7.	Toe-In Check and Adjustment	9-12
9-8.	Pitman Arm Replacement	9-14
9-9.	Steering Gear Adjustment	9-15
9-10.	Tie Rod and Tie Rod End Replacement	9-16
9-11.	Drag Link Replacement	9-18
9-12.	Steering Wheel Replacement	9-20

**9-7. TOE-IN CHECK AND ADJUSTMENT**

This task covers:

**a. Toe-In Check**

**b. Toe-In Adjustment**

INITIAL SETUP:

APPLICABLE MODELS

All

PERSONNEL REQUIRED

Two

REFERENCES (TM)

TM 9-2320-361-10

EQUIPMENT CONDITION

- Parking brake set (TM 9-2320-361-10).
- Tires inflated to proper pressure and uniform wear (TM 9-2320-361-10).
- Wheel bearings adjusted properly (para. 9-5).
- Steering gear adjusted properly (para. 9-9).

SPECIAL ENVIRONMENTAL CONDITIONS

Vehicle on level surface.

**a. Toe-In Check**

NOTE

- Ensure all steering system components are tight. If any steering component is damaged, replace. If loose, tighten.
- Steps 1 through 3 will determine centerline of tire.
- "Point of Measurement" for checking toe-in will be where lines marked in steps 1 and 3 intersect.

1. Mark line (1) on center tread (2) of tire (3) 18.3 in. (46.5 cm) from ground.
2. Measure total width of tire tread (4) and record.
3. Mark line (5) on center tread (2) at one-half total tread width (4).
4. Repeat steps 1 through 3 for opposite tire.
5. Measure distance between "Points of Measurement" on front side of tires (3) and record.
6. Rotate tires (3) by moving vehicle forward until "Points of Measurement" are 18.3 in. (46.5 cm) above the ground at rear side of tires (3).
7. Measure distance between "Points of Measurement" on rear side of tires (3) and record.

## 9-7. TOE-IN CHECK AND ADJUSTMENT (Contd)

### NOTE

- If measurement is larger on front side of tires than measurement on rear side of tires, tires have toe-out.
- If toe-in alignment does not meet specifications, repeat checking procedures to eliminate any possible reading errors.

8. Subtract measurement from front side of tires (3) step 5, from measurement from rear side of tires (3) step 7. The result of this subtraction represents inches of toe-in. Proper toe-in is 0.13 in.  $\pm$  0.06 in. (3.2 mm  $\pm$  1.6 mm).

### b. Toe-In Adjustment

1. Loosen two nuts (7) at each end of tie rod (6).
2. Turn tie rod (6) in 1/2 turn increments and measure toe-in until toe-in of .13 in.  $\pm$  .06 in. (3.2 mm  $\pm$  1.6 mm) is obtained.
3. When correct toe-in is obtained, tighten two nuts (7) 60 lb-ft (81 N $\ddot{m}$ ).

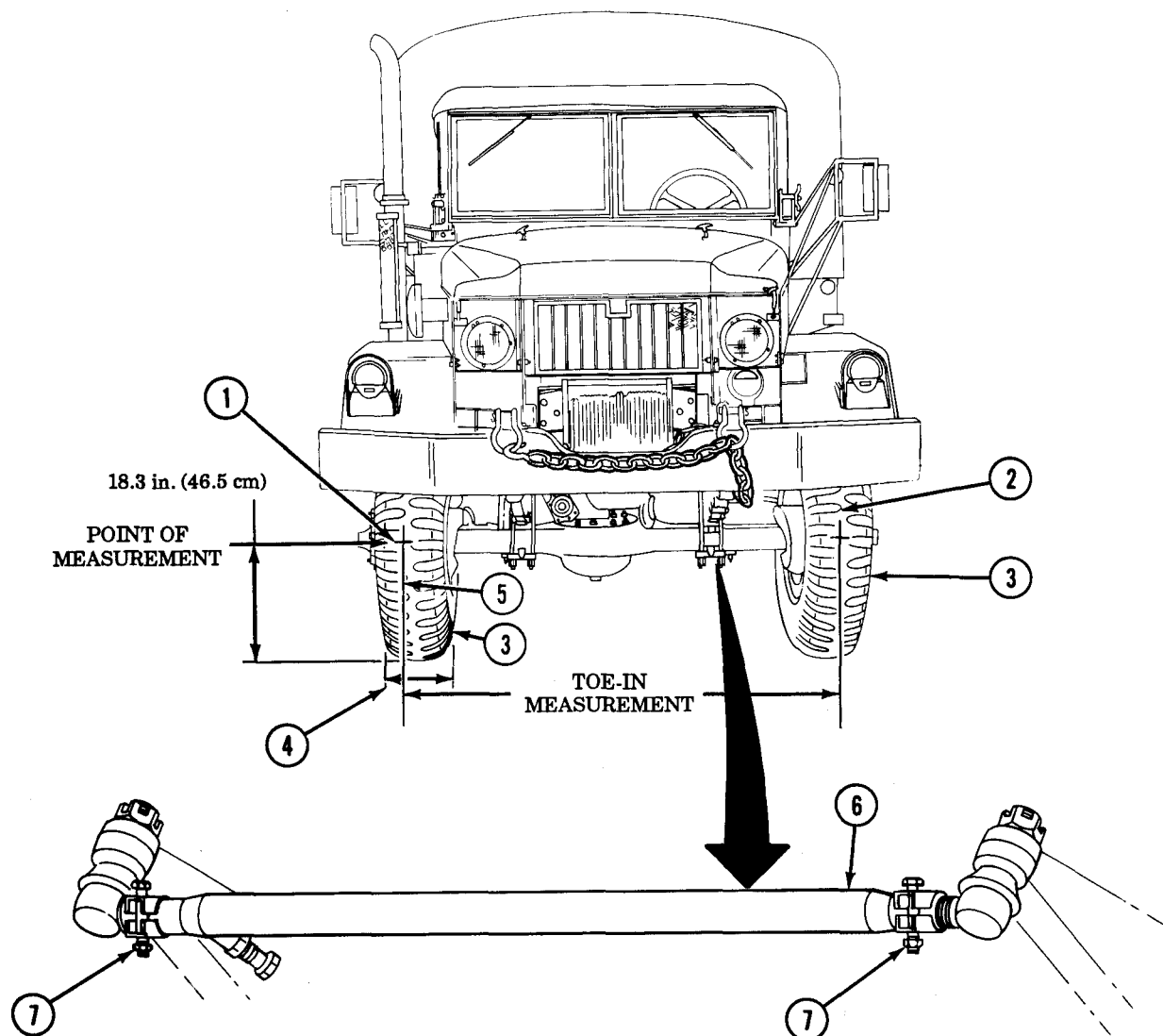

## 9-8. PITMAN ARM REPLACEMENT

This task covers:

### a. Removal

### b. Installation

INITIAL SETUP:

#### APPLICABLE MODELS

All

#### MATERIALS/PARTS

Cotter pin  
Lockwasher

#### REFERENCES (TM)

LO 9-2320-209-12-1  
TM 9-2320-361-10  
TM 9-2320-361-20P

#### EQUIPMENT CONDITION

Parking brake set (TM 9-2320-361-10).

### a. Removal

1. Remove cotter pin (6) from drag link (5). Discard cotter pin (6).
2. Unscrew adjusting plug (10) until it is almost out of drag link (5) end.
3. Turn steering wheel one-half turn right.

#### NOTE

Be careful not to let inner parts fall out of drag link when drag link is removed.

4. Remove drag link (5) from pitman arm (3).
5. Remove nut (1) and lockwasher (2) from shaft (4). Discard lockwasher (2).
6. Remove pitman arm (3) from shaft (4).

### b. Installation

1. Aline marks on pitman arm (3) and splined shaft (4) and slide pitman arm (3) on shaft (4) until screw end of shaft (4) comes through.
2. Install new lockwasher (2) and nut (1). Tighten nut (1) 180-200 lb-ft (244-271 NŹm).
3. Remove adjusting plug (10), safety plug (9), spring (8), and ball seat (7) from drag link (5).
4. Install ball of pitman arm (3) in slot of drag link (5). Install ball seat (7), spring (8), and safety plug (9), and start to screw in adjusting plug (10).
5. Lubricate drag link (5) (LO 9-2320-209-12-1).
6. Screw in adjusting plug (10) until seated, then back plug (10) off enough to install new cotter pin (6).

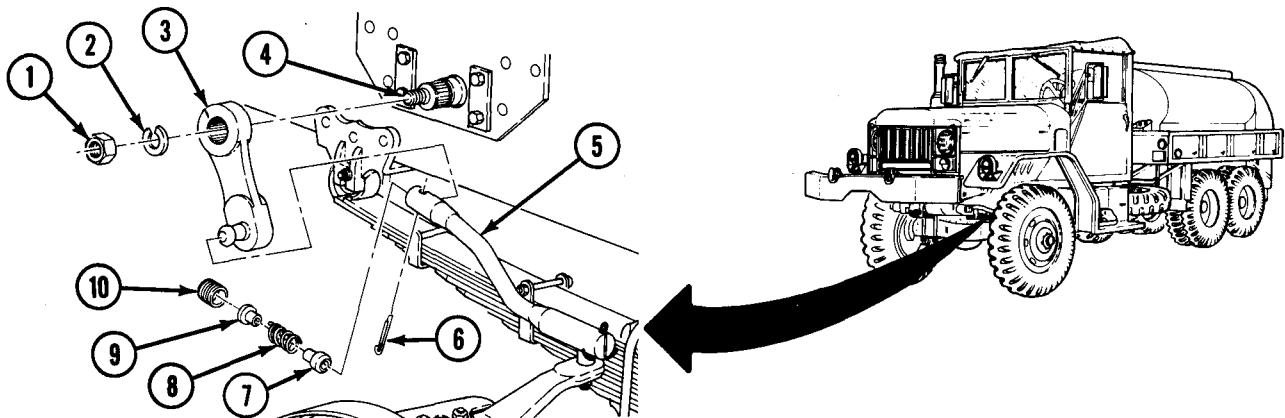

## 9-9. STEERING GEAR ADJUSTMENT

This task covers:

### Adjustment

#### INITIAL SETUP:

##### APPLICABLE MODELS

All

##### PERSONNEL REQUIRED

Two

##### REFERENCES (TM)

TM 9-2320-361-10

TM 9-2320-361-20P

##### EQUIPMENT CONDITION

- Parking brake set (TM 9-2320-361-10).
- Remove drag link from pitman arm (para. 9-11).
- Remove horn button (para. 4-30).

### Adjustment

#### NOTE

Ensure all steering system components are tight. If any steering component is damaged, replace. If loose, tighten.

1. Hold screw (4) still, loosen nut (5), then loosen screw (4).
2. Turn steering wheel (2) all the way to the right, then all the way to the left, counting the number of turns.
3. Turn steering wheel (2) right, half the number of turns counted.
4. Tighten screw (4) until it is slightly snug, and tighten nut (5).
5. Turn steering wheel (2) one turn each way around mid-position.

#### NOTE

Assistant will help with step 6.

6. With steering wheel (2) at mid-position, hold screw (4) still, loosen nut (5), then tighten screw (4) until torque at nut (3) on steering column (1) reads 9-35 lb-in. (1.0 -4.0 NŹm).
7. Hold screw (4) still and tighten nut (5).

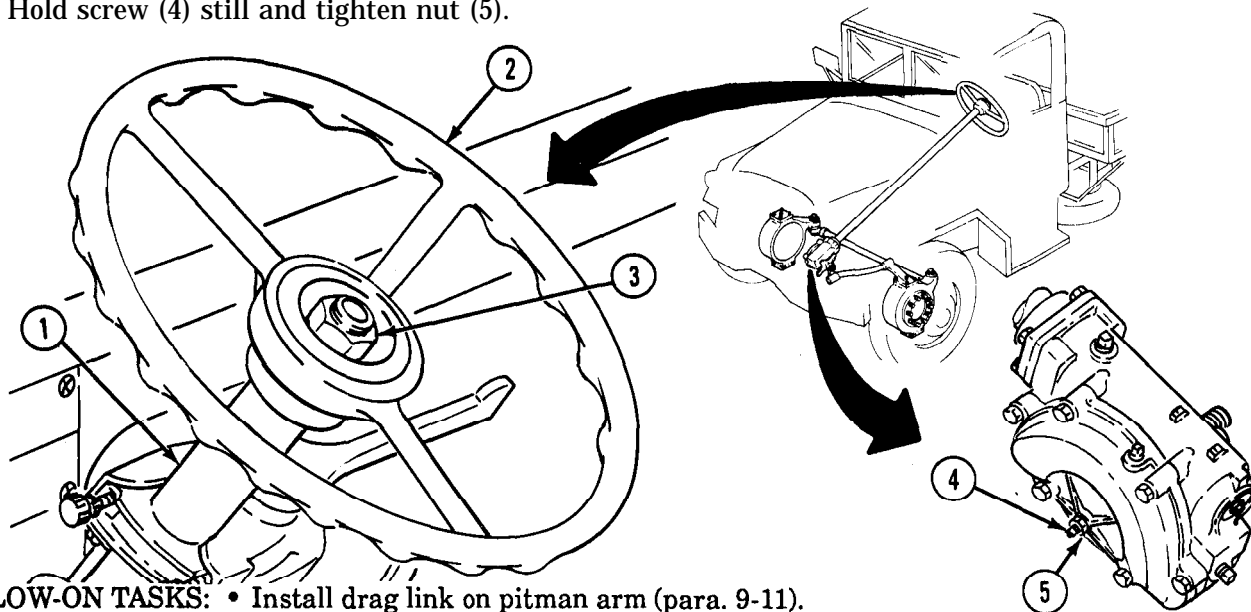

**FOLLOW-ON TASKS:**

- Install drag link on pitman arm (para. 9-11).
- Install horn button (para. 4-30).

## 9-10. TIE ROD AND TIE ROD END REPLACEMENT

This task covers:

**a. Removal**

**b. Installation**

**INITIAL SETUP:**

APPLICABLE MODELS

All

MATERIALS/PARTS

Cotter pin

REFERENCES (TM)

TM 9-2320-361-10

TM 9-2320-361-20P

EQUIPMENT CONDITION

- Rear wheels chocked (TM 9-2320-361-10).
- Parking brake set (TM 9-2320-361-10).

### a. Removal

**NOTE**

- Left tie rod end has left-hand threads. Right tie rod end has right-hand threads.
- Left and right tie rod ends are removed the same way. This procedure covers the left end only.

1. Lift front axle enough to take weight off front wheels (TM 9-2320-361-10).
2. Loosen nut (5) on clamp (4).
3. Remove cotter pin (3) and nut (1) from tie rod end (6). Discard cotter pin (3).
4. Remove tie rod end (6) from steering knuckle (7).
5. Remove tie rod end (6) from tie rod (2). Count how many turns it takes to unscrew tie rod end (6).
6. Remove boot (8) from tie rod end (6).
7. Lower front axle (TM 9-2320-361-10).

### b. Installation

**CAUTION**

Be careful when screwing in tie rod end, or damage to dust cover may result.

1. Screw tie rod end (6) into tie rod (2) the same number of turns as in removal.
2. Install boot (8) on tie rod end (6).
3. Install tie rod end (6) in steering knuckle (7) with nut (1) and new cotter pin (3). Tighten nut (1) 165-180 lb-ft (224-244 NŽm), and bend back ends of pin (3).
4. Tighten nut (5) on clamp (4) 170 lb-ft (231 NŽm).

9-10. TIE ROD AND TIE ROD END REPLACEMENT (Contd)

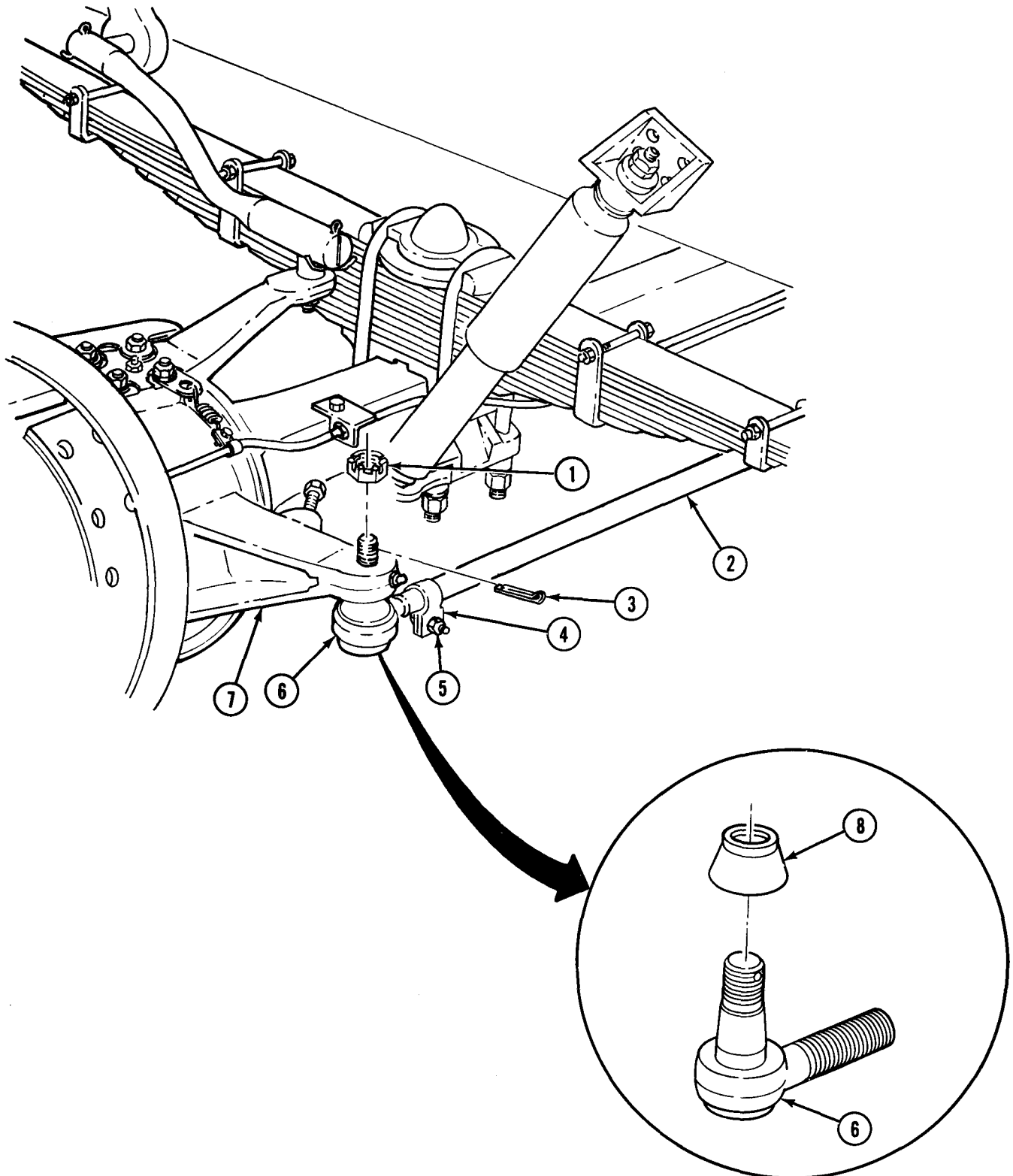

FOLLOW-ON TASK: Adjust toe-in (para. 9-7).

## 9-11. DRAG LINK REPLACEMENT

This task covers:

### a. Removal

### b. Installation

#### INITIAL SETUP

##### APPLICABLE MODELS

All

##### MATERIALS/PARTS

Two cotter pins

##### REFERENCES (TM)

LO 9-2320-209-12-1

TM 9-2320-361-10

TM 9-2320-361-20P

##### EQUIPMENT CONDITION

Parking brake set (TM 9-2320-361-10).

### a. Removal

1. Remove two cotter pins (6) and adjusting plugs (1) and (12) from drag link (7). Discard cotter pins (6).
2. Turn steering wheel as needed, and remove safety plug (2).
3. Remove drag link (7) from pitman arm (17), then lower end of drag link (7). Remove spring (3) and ball seats (4) and (5).
4. Remove ball seat (11) and lift drag link (7) from steering arm (13), then lower end of drag link (7) and remove ball seat (10), spring (9), and safety plug (8).
5. Remove two grease fittings (15) from drag link (7).

### b. Installation

#### CAUTION

Ensure drag link components are properly installed, or damage to equipment may result.

#### NOTE

The steering arm end of drag link is the side with the opening closest to end.

1. Install two grease fittings (15) on drag link (7).
2. Install safety plug (8), spring (9), and ball seat (10) in steering arm end of drag link (7).
3. Install drag link (7) on steering arm (13). Ensure ball seat (10) is caught on steering arm ball (14).
4. Install ball seat (11) and adjusting plug (12) in drag link (7).
5. Install ball seat (5) in pitman arm end of drag link (7).
6. Install drag link (7) on pitman arm (17). Ensure ball seat (5) is caught on pitman arm ball (16).
7. Install ball seat (4), spring (3), safety plug (2), and adjusting plug (1) in drag link (7).
8. Lubricate drag link (7) (LO 9-2320-209-12-1).
9. Tighten adjusting plugs (1) and (12) until seated, then back off plugs (1) and (12) until cotter pins (6) can be installed.
10. Install two new cotter pins (6) through drag link (7) and plugs (1) and (12). Secure cotter pins (6) by bending ends.

9-11. DRAG LINK REPLACEMENT (Contd)

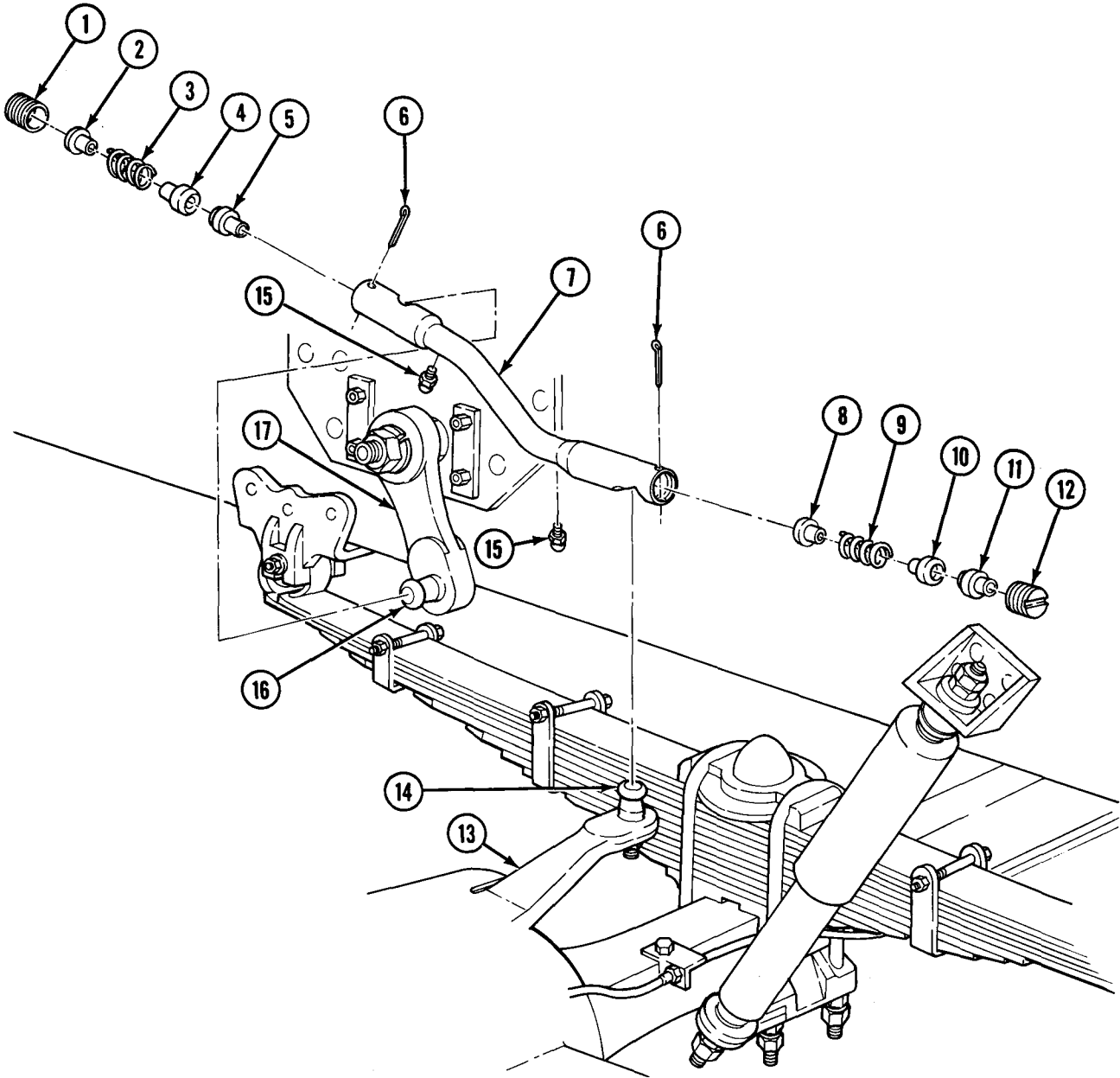



## 9-12. STEERING WHEEL REPLACEMENT

This task covers:

**a. Removal**

**b. Installation**

**INITIAL SETUP**

APPLICABLE MODELS

All

REFERENCES (TM)

TM 9-2320-361-10

TM 9-2320-361-20P

EQUIPMENT CONDITION

- Parking brake set (TM 9-2320-361-10).
- Horn button removed (para. 4-30).
- Wheels in straight-ahead position.

**a. Removal**

1. Loosen screw (6) and slide turn control (7) down steering column (8).

**NOTE**

Perform step 2 only if truck has airbrake hand control lever.

2. Loosen two screws (5) and slide airbrake hand control lever (4) down steering column (8).
3. Unscrew nut (2) until it is level with top of shaft (3).
4. Turn steering wheel (1) to straight-ahead position and install adapter (10) on steering wheel nut (2), and adapter (11) on steering column (8).
5. Install puller on adapters (10) and (11), and screw in puller screw (9) until steering wheel (1) pops loose.
6. Remove puller, adapters (10) and (11), nut (2), and steering wheel (1).

**b. Installation**

1. Place steering wheel (1) on shaft (3) in 10 o'clock, 2 o'clock, and 6 o'clock positions, and tap evenly on wheel (1) until nut (2) can be installed.
2. Install nut (2) and tighten.

**NOTE**

Perform step 3 only if truck has airbrake hand control lever.

3. Slide airbrake hand control valve (4) up steering column (8) and tighten two screws (5).
4. Slide turn signal control (7) up steering column (8) and tighten screw (6).

9-12. STEERING WHEEL REPLACEMENT (Contd)

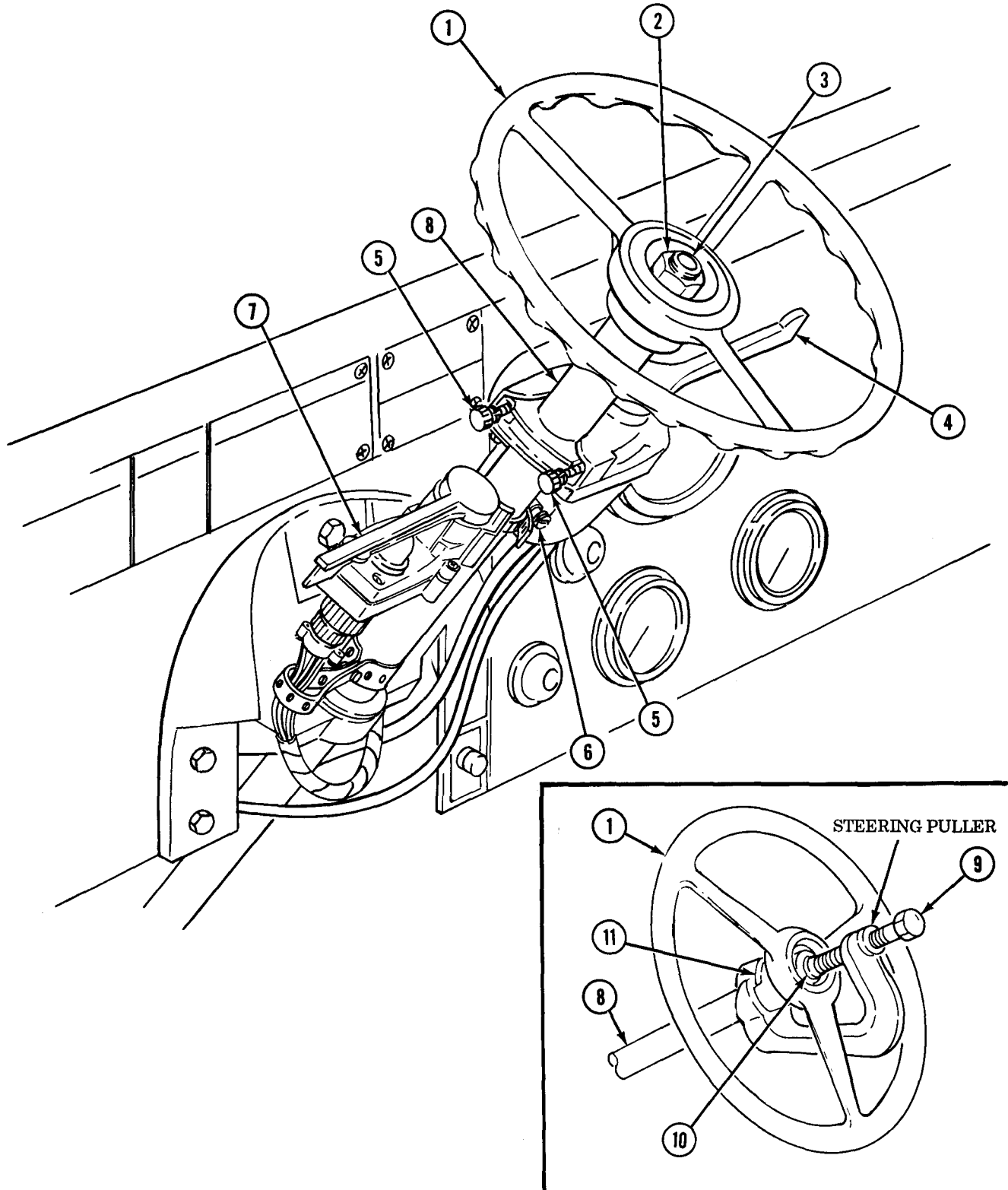

FOLLOW-ON TASK: Install horn button (para. 4-30).



## CHAPTER 10 FRAME MAINTENANCE

### 10-1. FRAME MAINTENANCE INDEX

PARA. NO.	TITLE	PAGE NO.
10-2.	Front Shackle (W/O Winch) Replacement	10-1
10-3.	Front Shackle (W/Winch) Replacement	10-3
10-4.	Pintle Hook Maintenance	10-4
10-5.	Rear Shackle Replacement	10-6
10-6.	Rear Bumperette Replacement	10-7
10-7.	Spare Tire Carrier Maintenance	10-8
10-8.	Brush Guard, Stone Shield, and Headlight Guard Replacement	10-10
10-9.	Front Bumper Replacement	10-12
10-10.	Front Winch Extension Replacement	10-14

### 10-2. FRONT SHACKLE (W/O WINCH) REPLACEMENT

This task covers:

**a. Removal**

**b. Installation**

#### INITIAL SETUP

APPLICABLE MODELS

All

MATERIALS/PARTS

Four locknuts

REFERENCES (TM)

TM 9-2320-361-10

TM 9-2320-361-20P

EQUIPMENT CONDITION

- Parking brake set (TM 9-2320-361-10).
- Brush guard removed (para. 10-8).

10-2. FRONT SHACKLE (W/O WINCH) REPLACEMENT (Contd)

1. Remove retaining pin (6) from pin (4).
2. Remove pin (4) and shackle (5) from bracket (12).
3. Remove two locknuts (9) and (7), two screws (1), screws (2) and (3), bracket (12), and brush guard bracket (11) from bumper (8) and frame rail (10). Discard locknuts (9) and (7).

1. Install brush guard bracket (11) and bracket (12) on frame rail (10) and bumper (8) with two screws (1), screws (2) and (3), and two new locknuts (7) and (9).
2. Install shackle (5) and pin (4) on bracket (12).
3. Install retaining pin (6) on pin (4). Latch retaining pin (6).

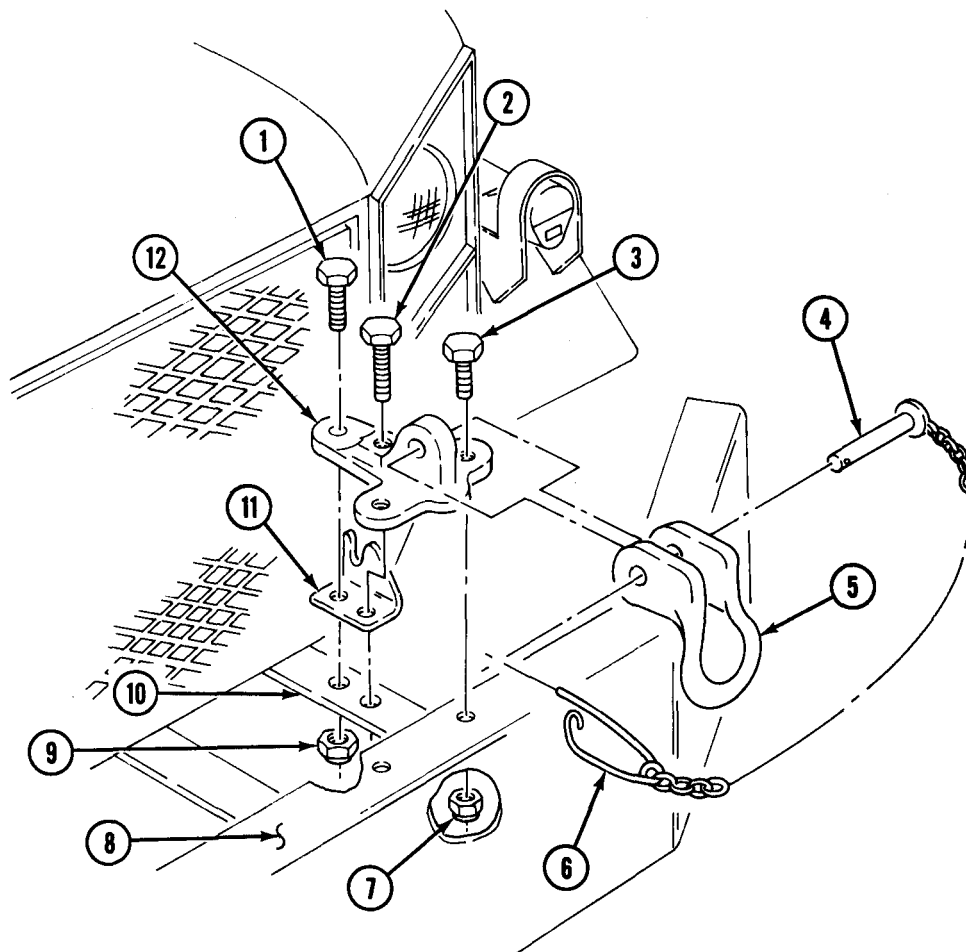

FOLLOW-ON TASK: Install brush guard (para. 10-8).

## 10-3. FRONT SHACKLE (W/WINCH) REPLACEMENT

This task covers:

### a. Removal

### b. Installation

INITIAL SETUP:

#### APPLICABLE MODELS

All

#### MATERIALS/PARTS

Four locknuts

#### REFERENCES (TM)

TM 9-2320-361-10

TM 9-2320-361-20P

#### EQUIPMENT CONDITION

Parking brake set (TM 9-2320-361-10).

### NOTE

Left shackle has two spacers and right shackle has only one. This procedure covers the left shackle and bracket.

### a. Removal

1. Remove retaining pin (6) from pin (5).
2. Remove pin (5), and shackle (4) from bracket (3).
3. Remove three locknuts (7), screws (2), and two spacers (9) from bracket (3) and bumper (8). Discard locknuts (7).
4. Remove locknut (10), screw (1), and bracket (3) from bumper (8). Discard locknut (10).

### b. Installation

1. Install bracket (3) on bumper (8) with screw (1) and new locknut (10).
2. Install two spacers (9), three screws (2), and new locknuts (7) on bracket (3) and bumper (8).
3. Install shackle (4) on bracket (3) with pin (5).
4. Install retaining pin (6) on pin (5). Latch retaining pin (6).

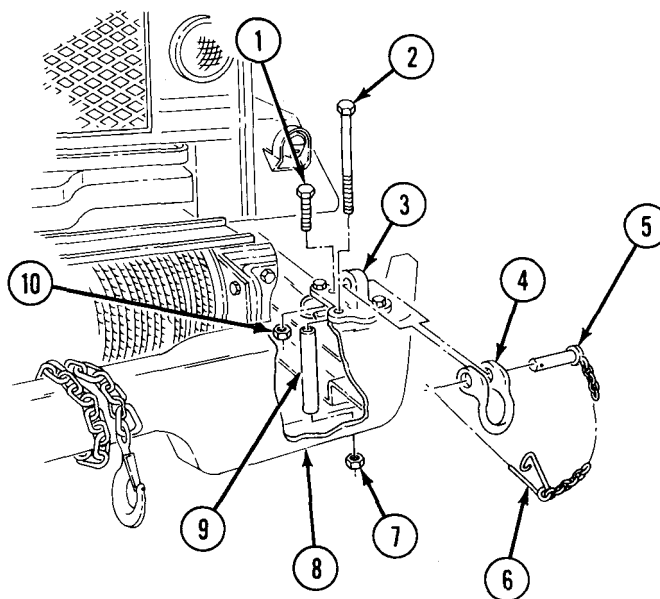

## 10-4. PINTLE HOOK MAINTENANCE

This task covers:

- |  |  |
|--|--|
| <ul style="list-style-type: none"> <li>a. Pintle Hook Removal</li> <li>b. Pintle Hook Latch Removal</li> <li>c. Cleaning and Inspection</li> </ul> | <ul style="list-style-type: none"> <li>d. Pintle Hook Latch Installation</li> <li>e. Pintle Hook Installation</li> </ul> |
|--|--|

### INITIAL SETUP:

#### APPLICABLE MODELS

All

#### MATERIALS/PARTS

Two locknuts  
 Three cotter pins  
 Rags (Appendix C, Item 21)  
 Drycleaning solvent (Appendix C, Item 26)

#### REFERENCES (TM)

LO 9-2320-209-12-1  
 TM 9-2320-361-10  
 TM 9-2320-361-20P

#### EQUIPMENT CONDITION

Parking brake set (TM 9-2320-361-10).

#### GENERAL SAFETY INSTRUCTIONS

Keep fire extinguisher nearby when using drycleaning solvent.

### a. Pintle Hook Removal

1. Remove cotter pin (21) from pintle hook (14) and nut (1). Discard cotter pin (21).
2. Remove nut (1), washer (2), and pintle hook (14) from rear crossmember (4).
3. Remove two locknuts (20), inner bracket (3), two screws (18), and outer bracket (19) from rear crossmember (4). Discard locknuts (20).

### b. Pintle Hook Latch Removal

1. Remove cotter pin (16) from lock (11). Discard cotter pin (16).
2. Remove two grease fittings (13) and (5) from drive pin (12) and screw (6).
3. Remove cotter pin (10) from screw (6) and slotted nut (9). Discard cotter pin (10).
4. Remove slotted nut (9), screw (6), and lock (11) from pintle hook (14).
5. Remove drive pin (12), latch (7), and spring (8) from lock (11).
6. Inspect drivescrew (15) and chain (17) for damage. Replace drivescrew (15) or chain (17) if damaged.

### c. Cleaning and Inspection

#### WARNING

Drycleaning solvent is flammable and will not be used near open flame. Use only in well-ventilated places. Failure to do so may result in injury to personnel.

1. Clean all parts with drycleaning solvent and dry with clean rag.
2. Inspect all parts for breaks and cracks. Replace all damaged parts.
3. Inspect spring (8) for breaks or collapsed coils. Replace if damaged.
4. Inspect for broken or missing chain (17), drivescrew (15), and cotter pin (16). Replace any broken or missing parts.
5. Replace grease fittings (5) and (13) if broken or missing.

## 10-4. PINTLE HOOK MAINTENANCE (Contd)

### d. Pintle Hook Latch Installation

1. Install drive pin (12) until flush with inside edge of lock (11).
2. Install spring (8) and latch (7) in lock (11) until drive pin (12) is flush with outside edge of lock (11).
3. Stake both edges of lock (11) in four places to hold drive pin (12) in place.
4. If removed, install drivescrew (15) and chain (17) on pintle hook (14) with new cotter pin (16).
5. Install lock (11) on pintle hook (14) with screw (6), slotted nut (9), and new cotter pin (10). Ensure lock (11) and latch (7) move freely.
6. Install two grease fittings (13) and (5) in pin (12) and screw (6).

### e. Pintle Hook Installation

1. Install inner bracket (3) and outer bracket (19) on rear crossmember (4) with two screws (18) and new locknuts (20).
2. Install pintle hook (14) on crossmember (4) with washer (2), and slotted nut (1). Tighten slotted nut (1) to obtain 0.003-0.017 in. (0.076-0.432 mm) clearance between washer (2) and inner bracket (3).
3. Install new cotter pin (21).

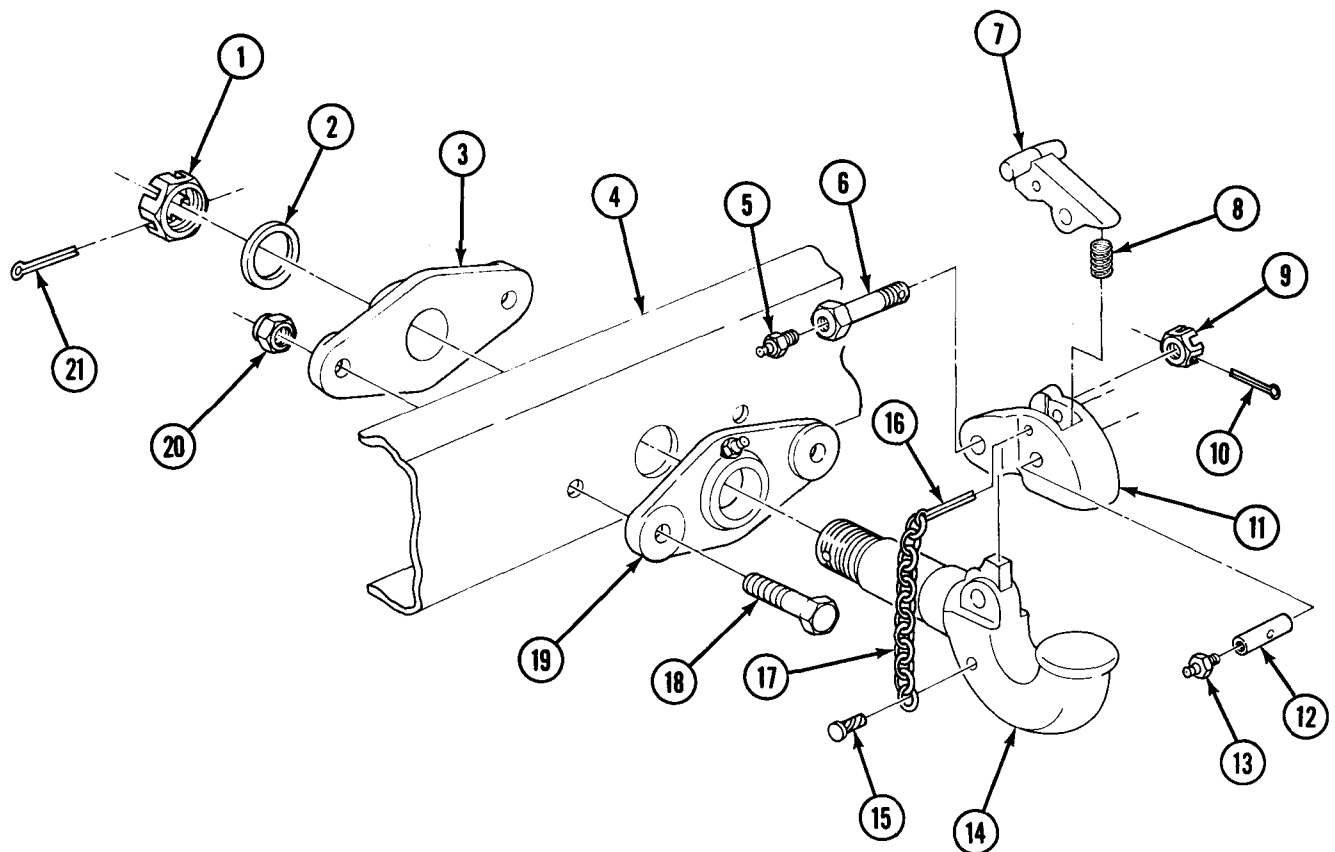

FOLLOW-ON TASK: Lubricate (LO 9-2320-209-12-1).



## 10-5. REAR SHACKLE REPLACEMENT

This task covers:

### a. Removal

### b. Installation

INITIAL SETUP:

#### APPLICABLE MODELS

All (except M275A2)

#### MATERIALS/PARTS

Three locknuts  
Cotter pin

#### REFERENCES (TM)

TM 9-2320-361-10

TM 9-2320-361-20P

#### EQUIPMENT CONDITION

- Parking brake set (TM 9-2320-361-10).
- Rear bumperettes removed (para. 10-6).

### a. Removal

1. Remove cotter pin (3) from pin (5). Discard cotter pin (3).
2. Remove pin (5) and shackle (4) from bracket (2).
3. Remove three locknuts (7), screws (6), and bracket (2) from crossmember (1). Discard locknuts (7).

### b. Installation

1. Install bracket (2) on crossmember (1) with three screws (6) and new locknuts (7).
2. Install shackle (4) on bracket (2) with pin (5).
3. Install new cotter pin (3) in pin (5).

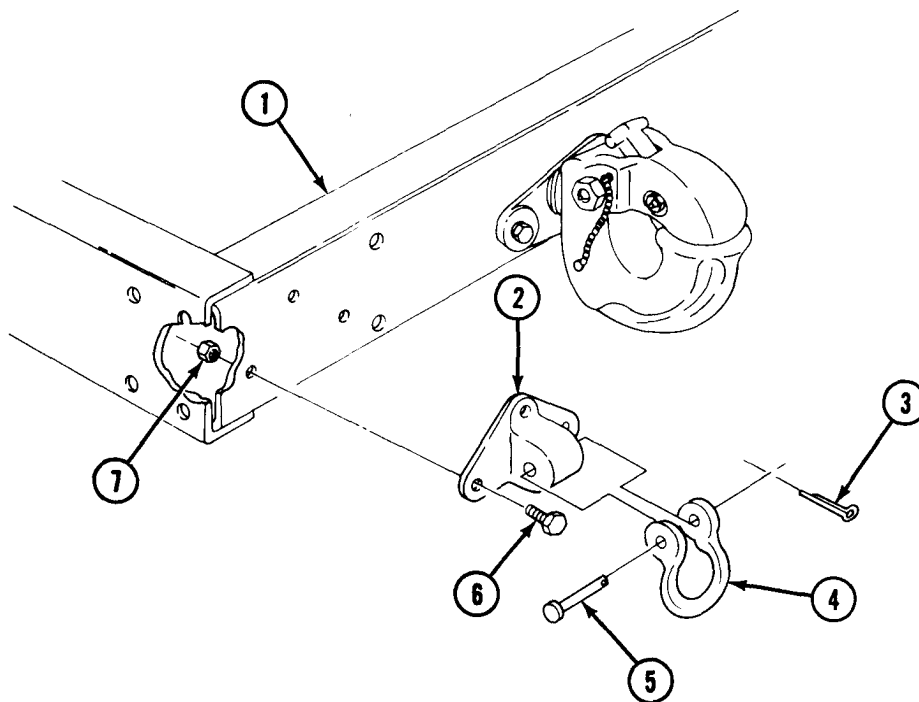

FOLLOW-ON TASK: Install rear bumperettes (para. 10-6).

## 10-6. REAR BUMPERETTE REPLACEMENT

This task covers:

### a. Removal

### b. Installation

INITIAL SETUP:

#### APPLICABLE MODELS

All (except M275A2,  
M764, M342A2)

#### MATERIALS/PARTS

Six locknuts

#### REFERENCES (TM)

TM 9-2320-361-10  
TM 9-2320-361-20P

#### EQUIPMENT CONDITION

- Parking brake set (TM 9-2320-361-10).
- Rear composite light removed (para. 4-46).

### a. Removal

1. Remove two locknuts (2) and screws (4) from crossmember (3) and rear bumperette (5). Discard locknuts (2).

#### NOTE

Wiring harness clamp is located on left side only.

2. Remove four locknuts (1), screws (7), composite light bracket (6), clamp (9), and rear bumperette (5) from frame (8). Discard locknuts (1).

### b. Installation

1. Install rear bumperette (5) on rear crossmember (3) with two screws (4) and new locknuts (2).

#### NOTE

Wiring harness clamp is located on left side only.

2. Install composite light bracket (6) and clamp (9) on bumperette (5) and frame (8) with four screws (7) and new locknuts (1).

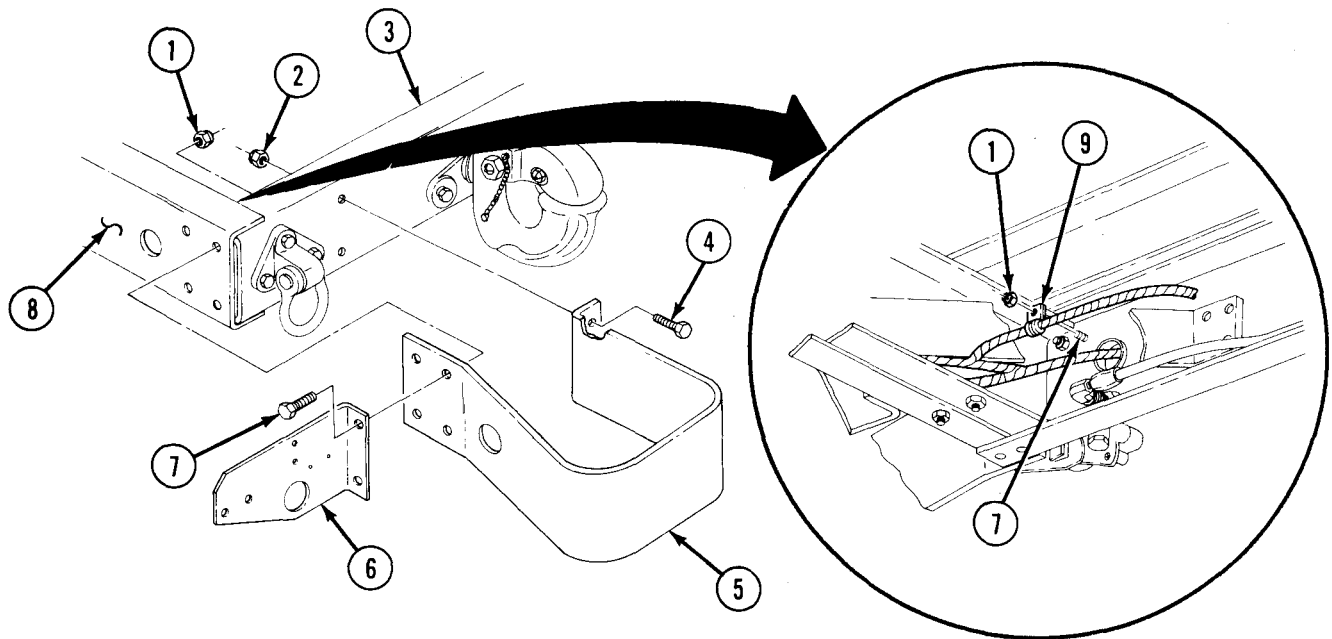

FOLLOW-ON TASK: Install rear composite light (para. 4-46).

## 10-7. SPARE TIRE CARRIER MAINTENANCE

This task covers:

- |   |  |
|---|--|
| <ul style="list-style-type: none"> <li>a. Removal</li> <li>b. Disassembly</li> <li>c. Inspection</li> </ul> | <ul style="list-style-type: none"> <li>d. Assembly</li> <li>e. Installation</li> </ul> |
|---|--|

### INITIAL SETUP:

#### APPLICABLE MODELS

All (except M342A2)

#### MATERIALS/PARTS

Four locknuts  
 Four lockwashers  
 Cotter pin

#### REFERENCES (TM)

TM 9-2320-361-10  
 TM -2320-361-20P

#### EQUIPMENT CONDITION

- Parking brake set (TM 9-2320-361-10).
- Spare tire removed (TM 9-2320-361-10).

#### GENERAL SAFETY INSTRUCTIONS

Wear leather gloves when handling cable.

### a. Removal

Remove four locknuts (3), screws (1), and spare tire carrier (2) from frame (4). Discard locknuts (3).

### b. Disassembly

1. Remove four nuts (10), lockwashers (11), two U-bolts (13), and ends of cable (7) from pickup member (14). Discard lockwashers (11).

#### WARNING

Wear leather gloves when handling cable. Do not let cable run through hands. Broken or rusty wires can cause injury to personnel.

2. Remove cable (7) from shaft (8).
3. Remove cotter pin (5) from shaft (8) and remove shaft (8) from housing (6). Discard cotter pin (5).

### c. Inspection

1. Inspect housing (6) for cracks, breaks, and broken welds. Replace housing (6) if cracked, bent, or welds are broken.
2. Inspect pickup member (14) for cracks, breaks, and loose studs (12). Replace pickup member (14) if cracked, broken, or studs (12) are loose.
3. Inspect shaft (8) and ratchet (9) for cracks, breaks, bends, and broken teeth on ratchet (9). Replace shaft (8) or ratchet (9) if cracked, broken, bent, or teeth are broken on ratchet (9).
4. Inspect cable (7) for breaks and frays. Replace cable (7) if broken or frayed.

## 10-7. SPARE TIRE CARRIER MAINTENANCE (Contd)

1. Install shaft (8) and ratchet (9) in housing (6) with new cotter pin (5).
2. Install ends of cable (7) through holes in shaft (8) and feed ends of cable (7) through hole in bottom of housing (6).

### NOTE

Ensure cable ends are of equal length through shaft.

3. Install two U-bolts (13) on pickup member (14) with four new lockwashers (11) and nuts (10). Do not tighten nuts (10).

### NOTE

Ensure cable ends extend through both U-bolts before tightening nuts in step 4.

4. Install ends of cable (7) through holes in pickup member (14) and U-bolts (13). Tighten nuts (10).

### e. Installation

Install spare tire carrier (2) on frame (4) with four screws (1) and new locknuts (3). Tighten locknuts (3) 30-35 lb-ft (41-47 N $\cdot$ m).

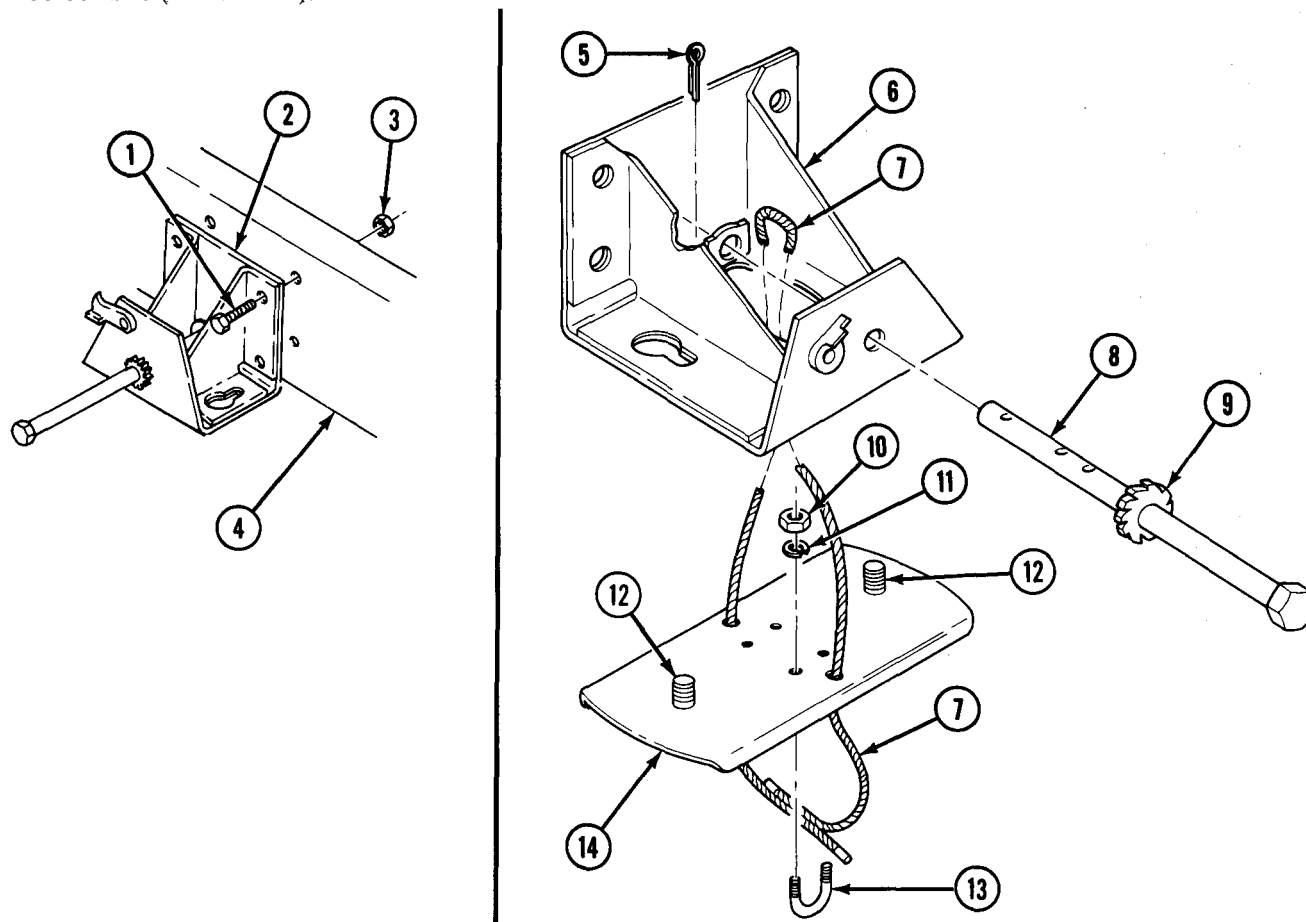

FOLLOW-ON TASK: Install spare tire (TM 9-2320-361-10).

**10-8. BRUSH GUARD, STONE SHIELD, AND HEADLIGHT GUARD REPLACEMENT**

This task covers:

- |                            |                                 |
|----------------------------|---------------------------------|
| a. Stone Shield Removal    | d. Headlight Guard Installation |
| b. Brush Guard Removal     | e. Brush Guard Installation     |
| c. Headlight Guard Removal | f. Stone Shield Installation    |

INITIAL SETUP:

APPLICABLE MODELS

All

MATERIALS/PARTS

Twenty-three locknuts

REFERENCES (TM)

TM 9-2320-361-10

TM 9-2320-361-20P

EQUIPMENT CONDITION

Parking brake set (TM 9-2320-361-10).

**a. Stone Shield Removal**

**NOTE**

- Radiator stone shield consists of an upper and lower stone shield. On vehicles with a front winch, a lower stone shield is not used.
- Some vehicles may have washers between brush guard and brush guard bracket.

1. Remove four locknuts (19), screws (10), two washers (15), and lower stone shield (9) from brush guard (4) and upper stone shield (7). Discard locknuts (19).
2. Remove three locknuts (5), screws (8), brackets (6), and upper stone shield (7) from brush guard (4). Discard locknuts (5).

**b. Brush Guard Removal**

1. Loosen two locknuts (16) and screws (18) from brush guard (4) and frame rail brackets (17). Discard locknuts (16).
2. Remove four locknuts (1) and (22), four washers (21) and (14), screws (20) and (13), and brush guard (4) from angle brackets (3). Discard locknuts (1) and (22).

**NOTE**

On vehicles without front winch, there is an additional brush guard bracket.

If vehicle is equipped with stone shield, proceed to step 4.

3. Remove two locknuts (19), screws (10), washers (15), and upper brush guard bracket (12) from brush guard (4).
4. Remove two locknuts (19), screws (10), washers (15), and lower brush guard bracket (11) from brush guard (4). Discard locknuts (19).

**c. Headlight Guard Removal**

**NOTE**

This procedure can also be done with brush guard installed on vehicle.

1. Remove four locknuts (1), screws (20), and washers (21) from brush guard (4). Discard locknuts (1).
2. If brush guard (4) was not removed from vehicle, remove two locknuts (22), washers (14), screws (13), and headlight guard (2) from brush guard (4). Discard locknuts (22).

## 10-8. BRUSH GUARD, STONE SHIELD, AND HEADLIGHT GUARD REPLACEMENT (Contd)

### d. Headlight Guard Installation

1. Install two headlight guards (2) on brush guard (4) with four screws (20) and (13), washers (21) and (14), and new locknuts (1) and (22).
2. If headlight guards (2) are being replaced, install inner ends of headlight guards (2) on brush guard (4) with two screws (13) and new locknuts (22).

### e. Brush Guard Installation

1. Install upper brush guard bracket (12) on brush guard (4) with two screws (10), washers (15), and new locknuts (19).
2. Install lower brush guard bracket (11) on brush guard (4) with two screws (10), washers (15), and new locknuts (19).
3. Position brush guard (4) on two frame rail brackets (17) and install with two screws (18) and new locknuts (16). Do not tighten locknuts (16).
4. Position brush guard (4) on angle brackets (3). Install four screws (13) and (20), washers (2) and (14), and locknuts (1) and (22) on brush guard (4), headlight guard (2), and two angle brackets (3). Tighten nuts (16).

### f. Stone Shield Installation

1. Install upper stone shield (7) on brush guard (4) with three screws (8), brackets (6), and new locknuts (5).
2. Install lower stone shield (9) on brush guard (4) with four screws (10), two washers (14), and four new locknuts (19).

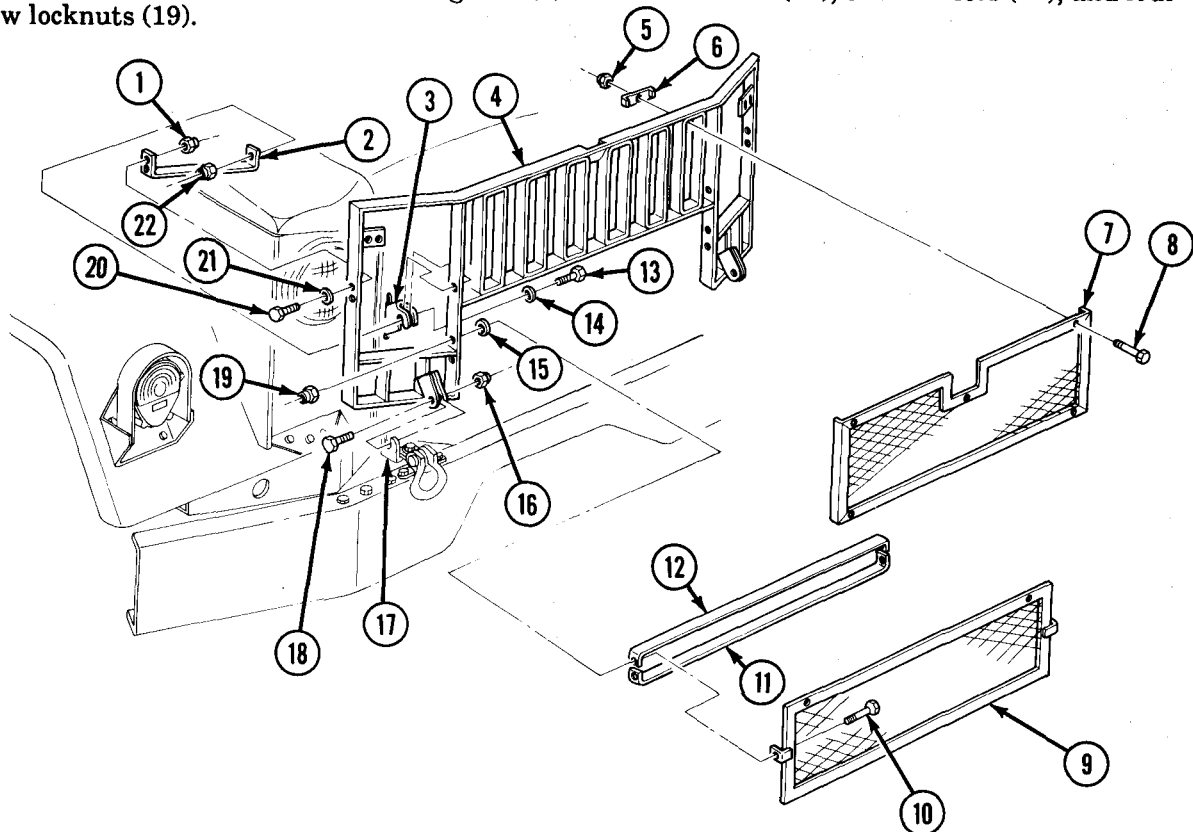

## 10-9. FRONT BUMPER REPLACEMENT

This task covers:

**a. Removal**

**b. Installation**

INITIAL SETUP:

APPLICABLE MODELS

All

REFERENCES (TM)

TM 9-2320-361-10

TM 9-2320-361-20P

MATERIALS/PARTS

Thirty locknuts (w/o winch)

Twenty-eight locknuts (w/winch)

EQUIPMENT CONDITION

- Parking brake set (TM 9-2320-361-10).
- Front lifting brackets and shackles removed (para. 10-2 for vehicles w/o winch) (para. 10-3 for vehicles w/winch).

PERSONNEL REQUIRED

Two

### a. Removal

**NOTE**

Perform step 1 for vehicles w/o winch. Perform step 2 for vehicles w/ winch.

1. Remove six locknuts (5) and screws (7) from bottom of bumper (2) and frame (4). Discard locknuts (5).
2. Remove four locknuts (5) and screws (7) and two lower plates (8) from frame (4). Discard locknuts (5).

**NOTE**

Assistant required to support bumper in step 2.

3. Remove bumper (2), two plates (3) and two plates (8) from frame (4).

**NOTE**

Mark plates for installation.

4. Remove twelve locknuts (6), screws (1), and two upper plates (3) from bumper (2). Discard locknuts (6).
5. Remove twelve locknuts (9), screws (10), and two lower plates (8) from bumper (2). Discard locknuts (9).

### b. Installation

1. Install two upper plates (3) on bumper (2) with twelve screws (1) and new locknuts (6).
2. Install two lower plates (8) on bumper (2) with twelve screws (10) and new locknuts (9).

**NOTE**

- Assistant required to support bumper in step 3.
- Perform step 3 for vehicles w/o winch. Perform step 4 for vehicles w/winch.

3. Install bumper (2), two plates (3) and two plates (8) on frame (4) with six screws (7) and new locknuts (5). Do not tighten screws (7).
4. Install bumper (2) and two plates (3) and (8) on frame (4) with four screws (7) and new locknuts (5). Do not tighten screws (7).
5. Install brackets and shackles on bumper (2) and frame (4) (paras. 10-2 and 10-3).
6. Tighten six screws (7) and locknuts (5).

10-9. FRONT BUMPER REPLACEMENT (Contd)

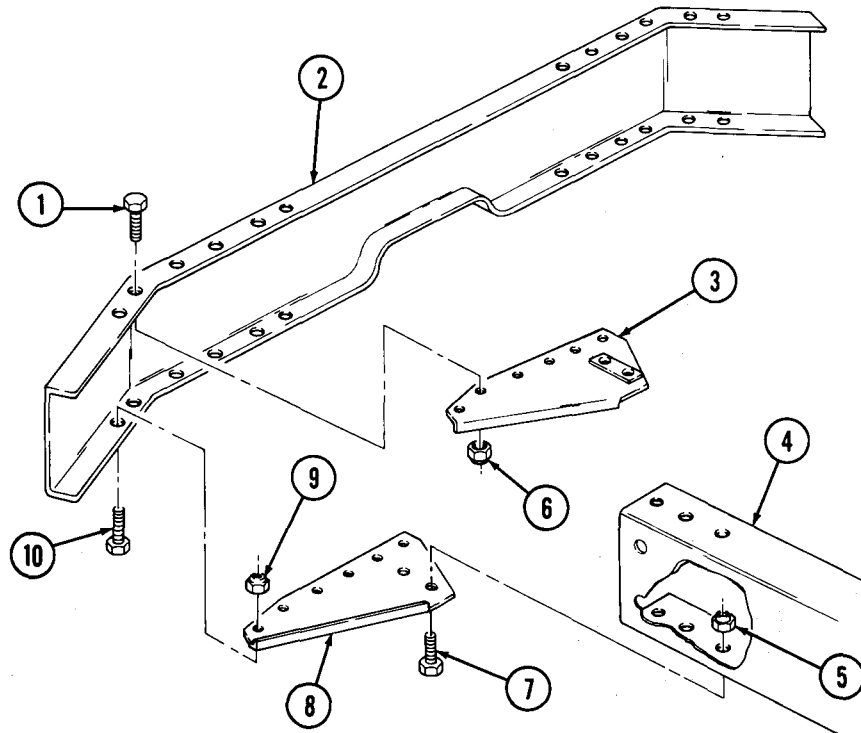

W/O WINCH

W/WINCH

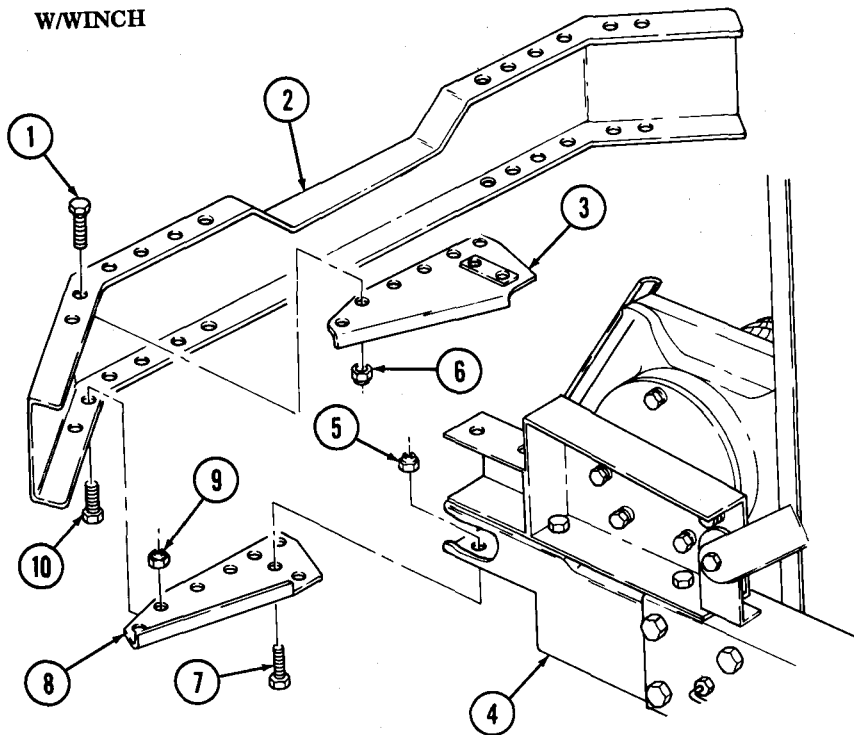

FOLLOW-ON TASK: Install front lifting brackets and shackles (w/o winch para. 10-2, wlwinch para. 10-3).



**10-10. FRONT WINCH EXTENSION REPLACEMENT**

This task covers:

**a. Removal**

**b. Installation**

INITIAL SETUP:

APPLICABLE MODELS

All

REFERENCES (TM)

TM 9-2320-361-10

TM 9-2320-361-20P

MATERIALS/PARTS

Ten locknuts

EQUIPMENT CONDITION

- Parking brake set (TM 9-2320-361-10).
- Front winch removed (para. 13-5).
- Brush guard removed (para. 10-8).

**a. Removal**

1. Remove four locknuts (5) and screws (3) from bottom of frame rail (2). Discard locknuts (5).
2. Remove six locknuts (4), screws (7), loop tiedown (1), and front winch extension (6) from frame rail (2). Discard locknuts (4).

**b. Installation**

1. Install front winch extension (6), and loop tiedown (1) on frame rail (2) with six screws (7) and new locknuts (4). Do not tighten nuts (4).
2. Install four screws (3) and new locknuts (5) through bottom of frame rail (2) and front winch extension (6).
3. Tighten nuts (5).

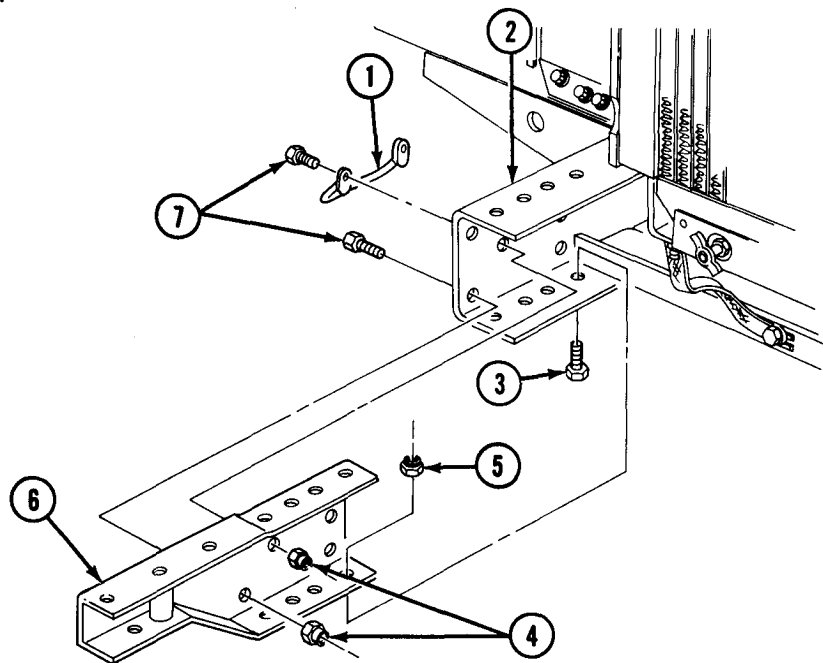

- FOLLOW-ON TASKS:
- Install front winch (para. 13-5).
  - Install brush guard (para. 10-8).

## CHAPTER 11 BODY, CAB, AND ACCESSORIES MAINTENANCE

Section I. Body and Cab Maintenance (page 11-1)

Section II. Accessories Maintenance (page 11-56)

### Section I. BODY AND CAB MAINTENANCE

#### 11-1. BODY AND CAB MAINTENANCE INDEX

PARA. NO.	TITLE	PAGE NO.
11-2.	Cab Door Inspection Hole Cover Replacement	11-2
11-3.	Cab Door Dovetail Wedge Replacement	11-3
11-4.	Cab Door and Hinges Replacement	11-4
11-5.	Cab Door Glass and Weatherseal Replacement	11-6
11-6.	Cab Door Window Regulator and Handle Replacement	11-8
11-7.	Outside Door Handle, Inside Door Handle, and Cab Door Lock Replacement	11-10
11-8.	Cab Door Check Rod Replacement	11-12
11-9.	Cab Door Catch Replacement	11-13
11-10.	Cab Door Weatherseals Replacement	11-14
11-11.	Side Panel Replacement	11-16
11-12.	Headlight Bracket Replacement	11-18
11-13.	Hood Fasteners Replacement	11-20
11-14.	Hood Maintenance	11-22
11-15.	Hood Hinges Replacement	11-24
11-16.	Cab Handle Replacement	11-25
11-17.	Cab Cowl Vent Replacement	11-26
11-18.	Glove Compartment Replacement	11-28
11-19.	Toolbox (Under Cab) Replacement	11-29
11-20.	Windshield Assembly Maintenance	11-30
11-21.	Windshield Arm, Glass and Handle Replacement	11-34
11-22.	Cab Tunnel, Rear Tunnel, and Toeboard Replacement	11-36
11-23.	Rear Cab Mount Replacement	11-38
11-24.	Water Can Bracket and Running Board Replacement	11-40
11-25.	Cab Soft Top Turnbuttons and Lashing Hooks Replacement	11-41
11-26.	Companion Seat Maintenance	11-42
11-27.	Driver's Seat Base Maintenance	11-44
11-28.	Driver's Seat Replacement	11-49
11-29.	Driver's Seat Cushion, Backrest, Frame, and Seat Adjuster Replacement	11-50
11-30.	Front Fenders Maintenance	11-52

## 11-2. CAB DOOR INSPECTION HOLE COVER REPLACEMENT

### This task covers

#### a. Removal

#### b. Installation

#### INITIAL SETUP:

##### APPLICABLE MODELS

All

##### EQUIPMENT CONDITION

Parking brake set (TM 9-2320-361-10).

##### REFERENCES (TM)

TM 9-2320-361-10

TM 9-2320-361-20P

#### a. Removal

Remove six screws (2) and cab door inspection hole cover (3) from cab door (1).

#### b. Installation

Install cab door inspection hole cover (3) on cab door (1) with six screws (2).

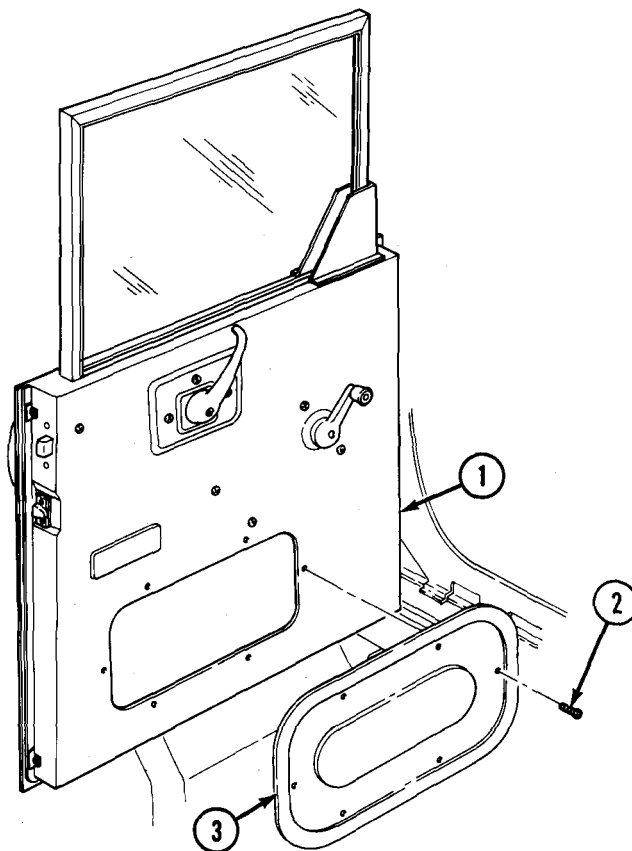

## 11-3. CAB DOOR DOVETAIL WEDGE REPLACEMENT

This task covers:

### a. Removal

### b. Installation

INITIAL SETUP:

#### APPLICABLE MODELS

All

#### MATERIALS/PARTS

Two screw-assembled lockwashers

#### REFERENCES (TM)

TM 9-2320-361-10

TM 9-2320-361-20P

#### EQUIPMENT CONDITION

Parking brake set (TM 9-2320-361-10).

### a. Removal

Remove two screw-assembled lockwashers (1), dovetail wedge (2), and shim (3) from cab door (4). Discard screw-assembled lockwashers (1).

### b. Installation

Install shim (3) and dovetail wedge (2) on cab door (4) with two new screw-assembled lockwashers (1).

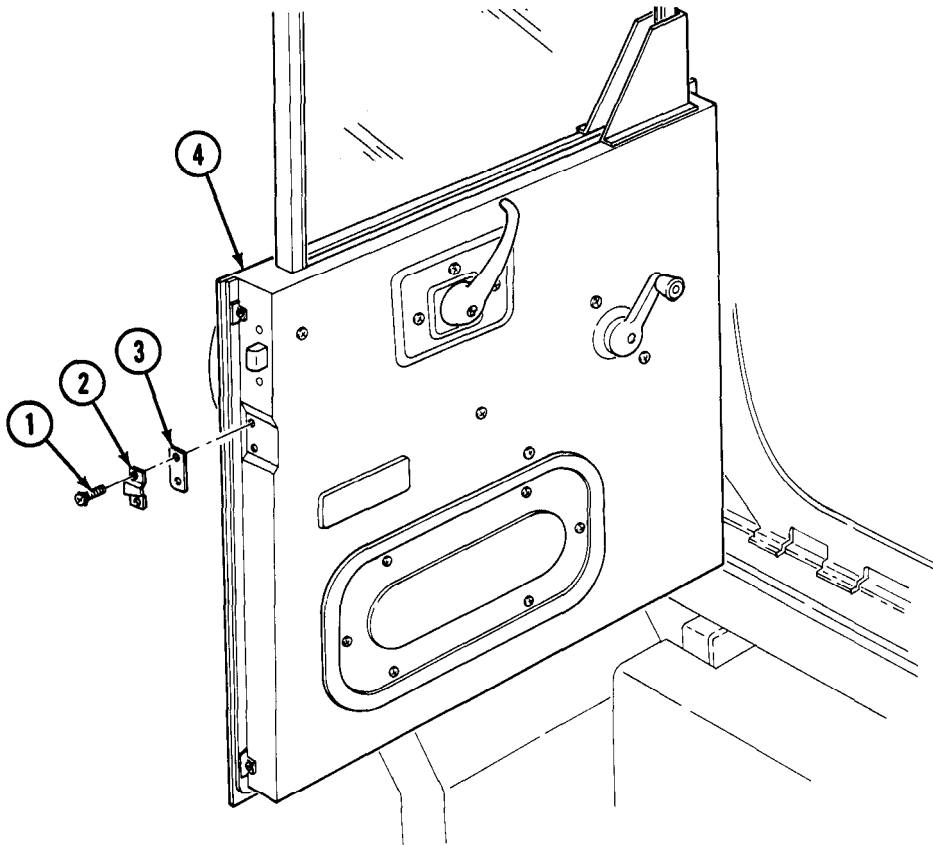

## 11-4. CAB DOOR AND HINGES REPLACEMENT

This task covers:

a. Cab Door Removal

b. Cab Door Hinges Removal

c. Cab Door Hinges Installation

d. Cab Door Installation

INITIAL SETUP:

APPLICABLE MODELS

All

MATERIALS/PARTS

Two locknuts

PERSONNEL REQUIRED

Two

REFERENCES (TM)

TM 9-2320-361-10

TM 9-2320-361-20P

EQUIPMENT CONDITION

- Parking brake set (TM 9-2320-361-10).
- Cab door lock removed (para. 11-7).
- Cab door dovetail wedge removed (para. 11-3).
- Cab door weatherseal removed (para. 11-10).
- Cab door window regulator removed (para. 11-6).
- Cab door check rod removed (para. 11-8).
- Side panel removed (para. 11-11).

### a. Cab Door Removal

#### NOTE

Assistant will help with steps 1 and 2.

1. Remove two locknuts (6), washers (7), and hinge screws (1) from three mirror braces (2) and two cab door hinges (4). Discard locknuts (6).
2. Remove cab door (5) from hinges (9) mounted on cab (8) "A" pillar (10).

### b. Cab Door Hinges Removal

Remove sixteen screws (3) and cab door hinges (4) and (9) from cab door (5) and cab (8) "A" pillar (10).

### c. Cab Door Hinges Installation

Install two cab door hinges (4) on cab door (5) and two hinges (9) on cab (8) "A" pillar (10) with sixteen screws (3).

### d. Cab Door Installation

#### NOTE

Assistant will help with steps 1 and 2.

1. Lift cab door (5) and position cab door hinges (4) to hinges (9) mounted on cab (8) "A" pillar (10) and align three mirror braces (2) to hinges (4) and (9).
2. Install two hinge screws (1) through three mirror braces (2) and hinges (4) and (9).
3. Install two washers (7) and two new locknuts (6) on hinge screws (1). Tighten locknuts (6).

## 11-4. CAB DOOR AND HINGES REPLACEMENT (Contd)

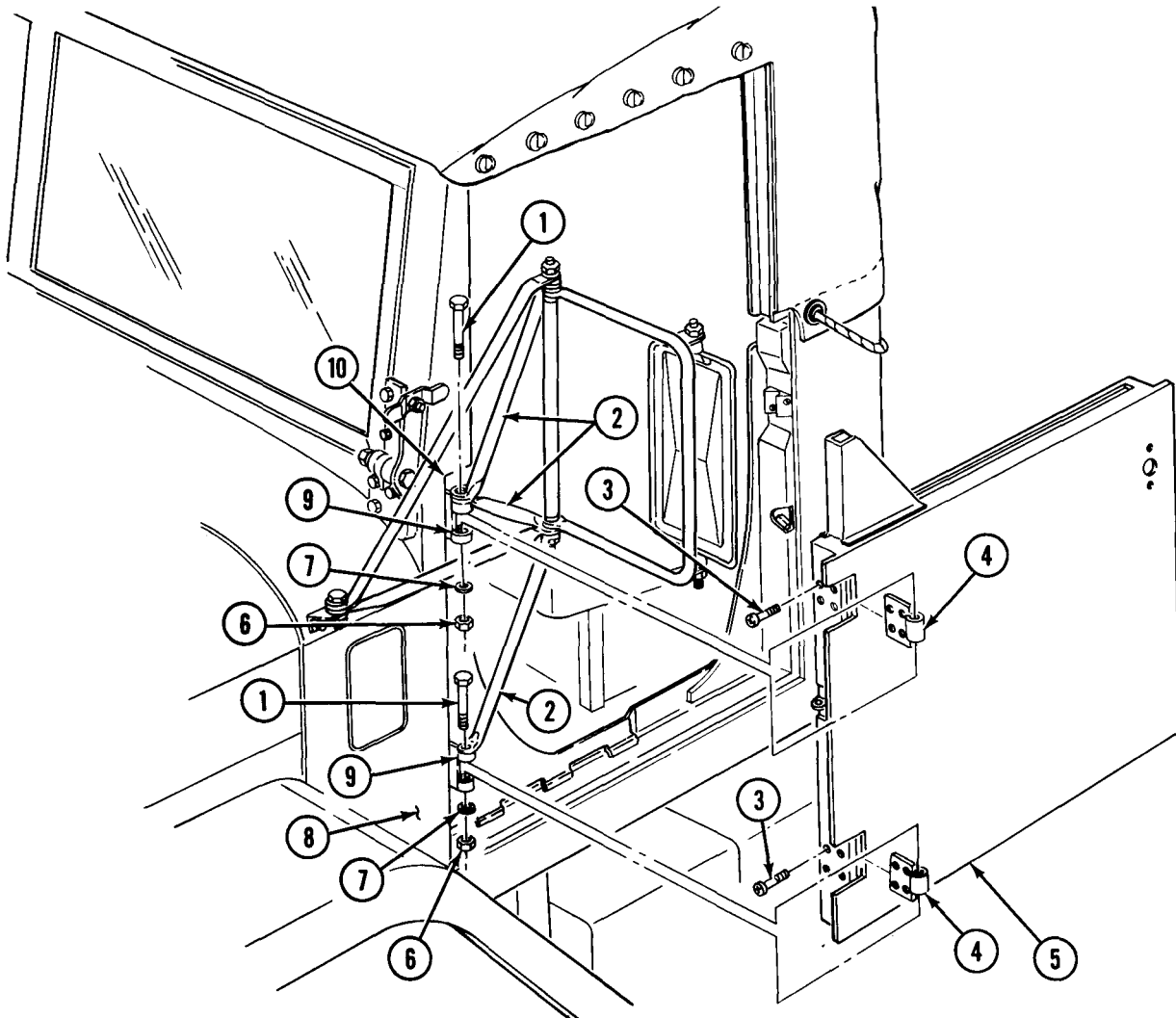

- FOLLOW-ON TASKS: Ž Install cab door weatherseal (para. 11-10).
- Install cab door check rod (para. 11-8).
  - Install cab door window regulator (para. 11-6).
  - Install cab door dovetail wedge (para. 11-3).
  - Install cab door lock (para. 11-7).
  - Install side panel (para. 11-11).

**11-5. CAB DOOR GLASS AND WEATHERSEAL REPLACEMENT**

This task covers:

- a. Removal
- b. Installation

c. Cab Door Glass Adjustment

**INITIAL SETUP:**

APPLICABLE MODELS

All

MATERIALS/PARTS

Two fasteners  
Four lockwashers

REFERENCES (TM)

TM 9-2320-361-10  
TM 9-2320-361-20P

EQUIPMENT CONDITION

- Parking brake set (TM 9-2320-361-10).
- Cab door inspection hole cover removed (para. 11-2).

**a. Removal**

1. Lower cab door glass (8) so regulator channels (2) are accessible through cab door (4) inspection hole.

**NOTE**

Mark position of regulator stop brackets for installation.

2. Remove four screws (7), lockwashers (6), and two window regulator stop brackets (5) from regulator channels (2), Discard lockwashers (6).
3. Remove two fasteners (1) from window regulator arm studs (3). Discard two fasteners (1).
4. Pull two regulator arm studs (3) out of two regulator channels (2) and slide cab door glass (8) out of cab door (4).
5. Remove weatherseal (10) from cab door (4).
6. Remove five clips (9) from weatherseal (10).

**b. Installation**

1. Install five clips (9) to weatherseal (10) and align clips (9) with panel slots (11).
2. Install weatherseal (10) and clips (9) on cab door (4) so clips (9) snap into corresponding panel slots (11).
3. Slide cab door glass (8) into cab door (4) and install two window regulator arm studs (3) through two regulator channels (2).
4. Install two new fasteners (1) on window regulator arm studs (3).
5. Install two window regulator stop brackets (5) on regulator channels (2) with four new lockwashers (6) and screws (7). Do not tighten.

**c. Cab Door Glass Adjustment**

1. Raise cab door glass (8) to full up position.

**11-5. CAB DOOR GLASS AND WEATHERSEAL REPLACEMENT (Contd)**

NOTE

Ensure cab door glass meets glass seal at top with door in closed position.

2. Lower cab door glass (8) and tighten screws (7).

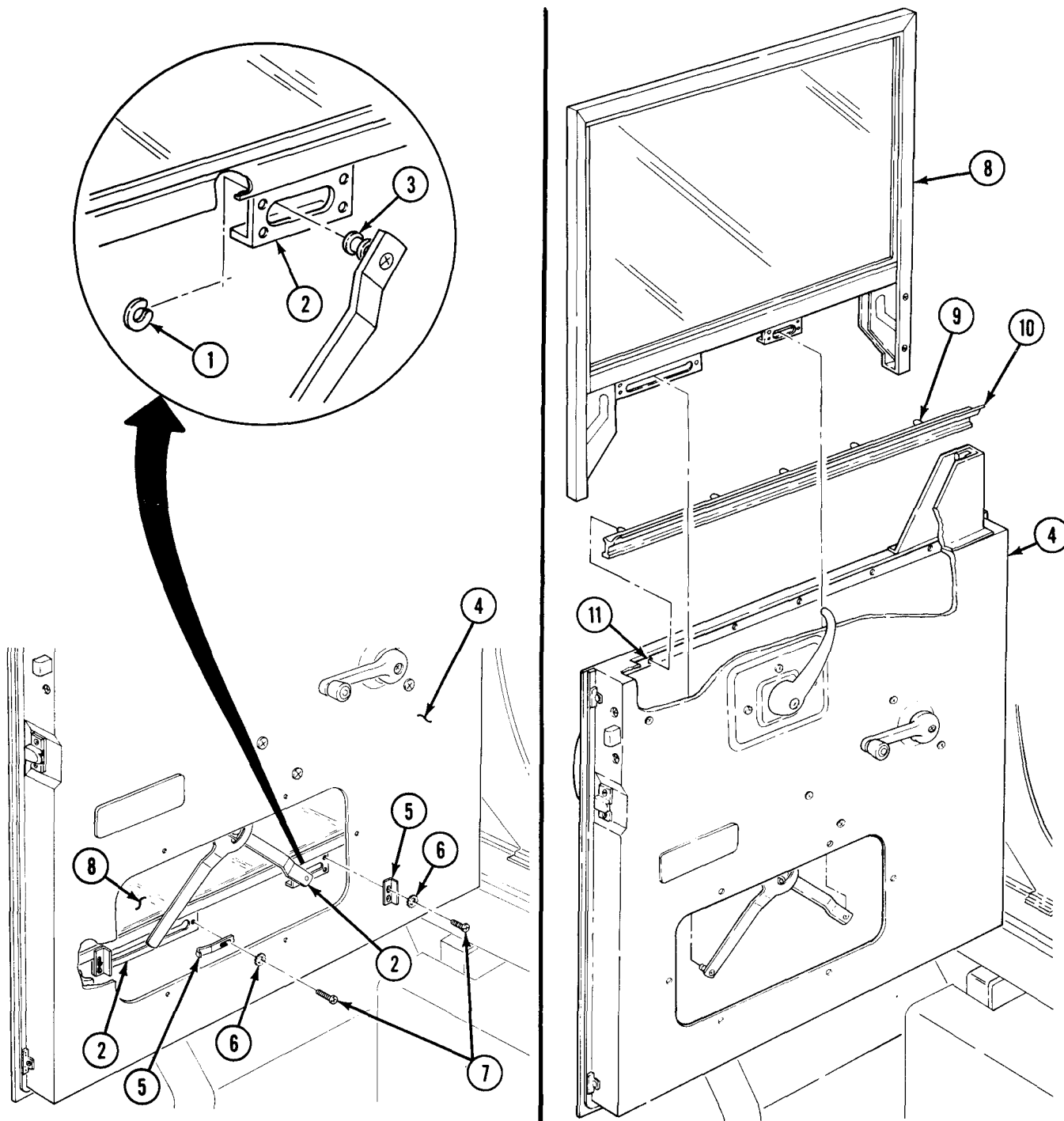

FOLLOW-ON TASK Install door inspection hole cover (para. 11-2).



## 11-6. CAB DOOR WINDOW REGULATOR AND HANDLE REPLACEMENT

This task covers:

- |   |  |
|---|--|
| <b>a. Window Regulator Handle Removal</b>   | <b>c. Cab Door Window Regulator Installation</b> |
| <b>b. Cab Door Window Regulator Removal</b> | <b>d. Window Regulator Handle Installation</b>   |

INITIAL SETUP:

APPLICABLE MODELS

All

REFERENCES (TM)

TM 9-2320-361-10

TM 9-2320-361-20P

EQUIPMENT CONDITION

- Parking brake set (TM 9-2320-361-10).
- Cab door glass removed (para. 11-5).

### a. Window Regulator Handle Removal

Remove screw (6), window regulator handle (5), and washer (4) from cab door window regulator (7).

### b. Cab Door Window Regulator Removal

**NOTE**

Cab door window regulator must be supported as last screw is removed.

1. Remove four screws (3) from inner door panel (2) and cab door window regulator (7).
2. Slide regulator arm stud (8) out of stationary track (9) and remove cab door window regulator (7) through cab door (1) inspection hole.

### c. Cab Door Window Regulator Installation

1. Install window regulator (7) through cab door (1) inspection hole and slide regulator arm stud (8) into stationary track (9).

**NOTE**

Regulator arm stud must be held in stationary track when installing window regulator to inner door panel.

2. Install window regulator (7) on inner door panel (2) with four screws (3).

### d. Window Regulator Handle Installation

Install washer (4) and window regulator handle (5) on window regulator (7) with screw (6).

11-6. CAB DOOR WINDOW REGULATOR AND HANDLE REPLACEMENT (Contd)

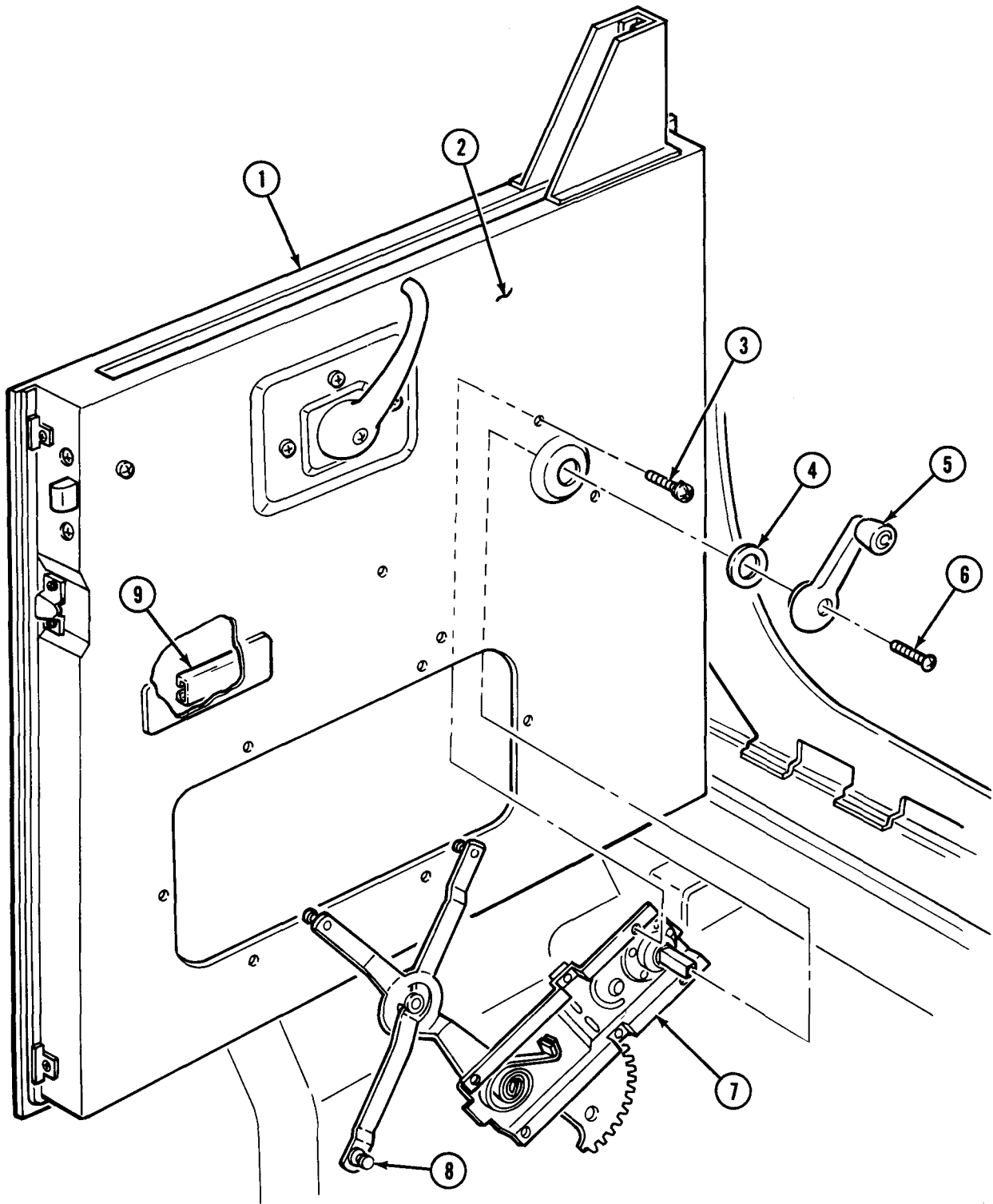

FOLLOW-ON TASK: Install cab door glass (para. 11-5).

## 11-7. OUTSIDE DOOR HANDLE, INSIDE DOOR HANDLE, AND CAB DOOR LOCK REPLACEMENT

This task covers:

- a. Outside Door Handle Removal
- b. Inside Door Handle Removal
- c. Cab Door Lock Removal

- d. Cab Door Lock Installation
- e. Inside Door Handle Installation
- f. Outside Door Handle Installation

INITIAL SETUP:

### APPLICABLE MODELS

All

### MATERIALS/PARTS

Six screw-assembled lockwashers

### REFERENCES (TM)

TM 9-2320-361-10

TM 9-2320-361-20P

### EQUIPMENT CONDITION

- Parking brake set (TM 9-2320-361-10).
- Cab door inspection hole cover removed (para. 11-2).

### **a. Outside Door Handle Removal**

1. Remove two screws (1) from door handle (8) and door (4).
2. Rotate door handle (8) 1/4 turn counterclockwise and remove from cab door (4).

### **b. Inside Door Handle Removal**

Remove screw (5), door handle (3), and washer (2) from cab door lock (7).

### **c. Cab Door Lock Removal**

1. Remove six screw-assembled lockwashers (6) from cab door (4). Discard screw-assembled lockwashers (6).
2. Remove cab door lock (7) through inspection hole in cab door (4).

### **d. Cab Door Lock Installation**

1. Install cab door lock (7) through inspection hole in cab door (4).
2. Install cab door lock (7) on cab door (4) with six new screw-assembled lockwashers (6).

### **e. Inside Door Handle Installation**

Install washer (2) and door handle (3) on cab door lock (7) with screw (5).

### **f. Outside Door Handle Installation**

Install outside door handle (8) on cab door (4) with two screws (1).

11-7. OUTSIDE DOOR HANDLE, INSIDE DOOR HANDLE, AND CAB DOOR LOCK REPLACEMENT (Contd)

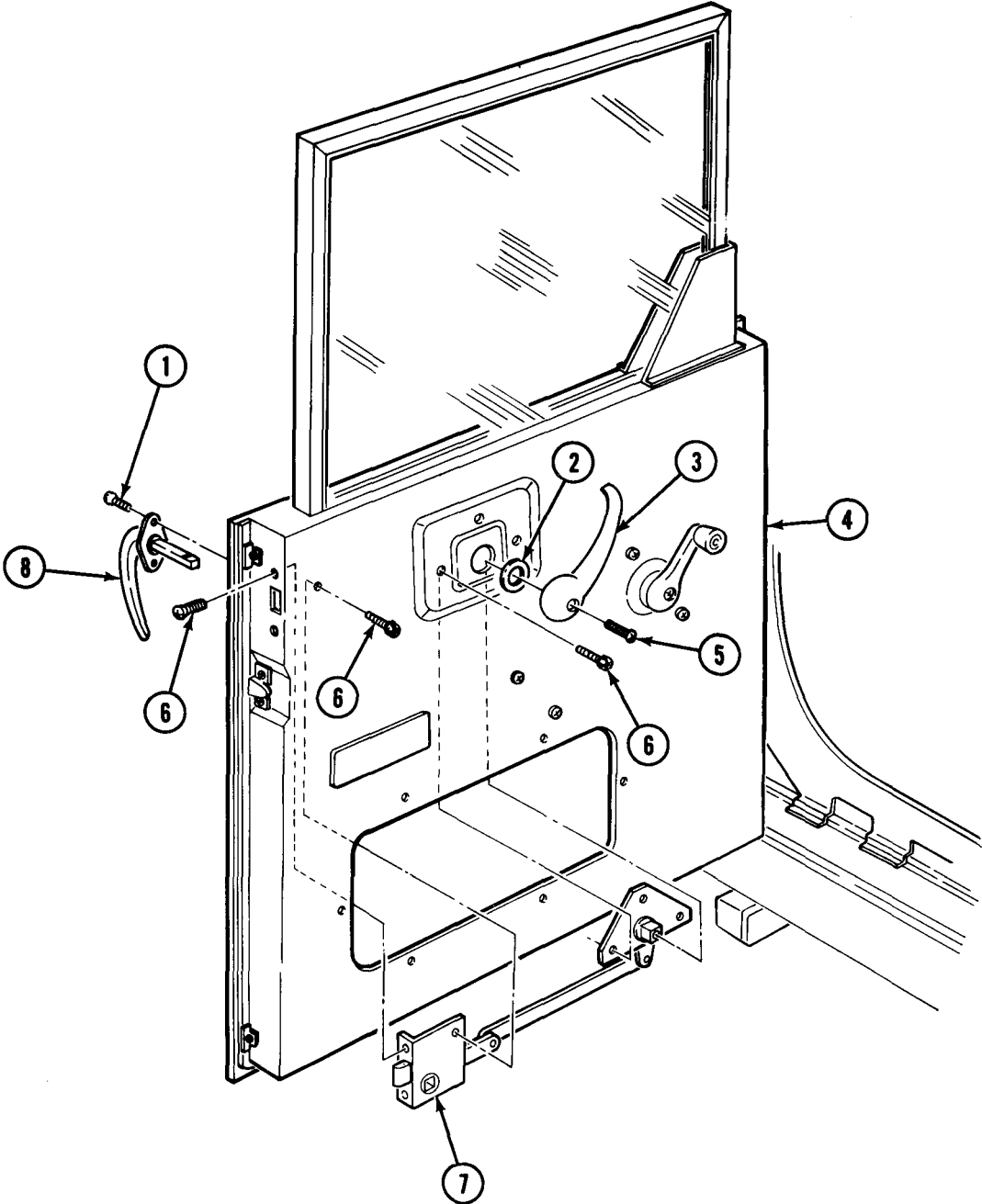

FOLLOW-ON TASK: Install cab door inspection hole cover (para. 11-2).

## 11-8. CAB DOOR CHECK ROD REPLACEMENT

This task covers:

### a. Removal

### b. Installation

INITIAL SETUP:

#### APPLICABLE MODELS

All

#### REFERENCES (TM)

TM 9-2320-361-10

TM 9-2320-361-20P

#### MATERIALS/PARTS

Cotter pin

#### EQUIPMENT CONDITION

Parking brake set (TM 9-2320-36 1-10).

### a. Removal

1. Remove cotter pin(1) from cab door check rod (2), pillar (4), and cabdoor (3). Discard cotter pin(1).
2. Open air vent door (6) and remove cab door check rod (2) and pad (5).
3. Remove pad (5) from rod (2).

### b. Installation

1. Install pad (5) on cab door check rod (2), and insert cab door check rod (2) through pillar (4).
2. Connect cab door check rod (2) to cab door (3) with new cotter pin (1).
3. Close air vent door (6).

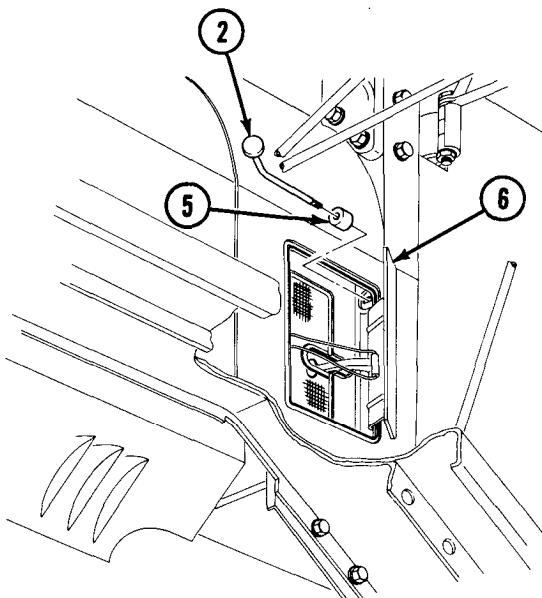
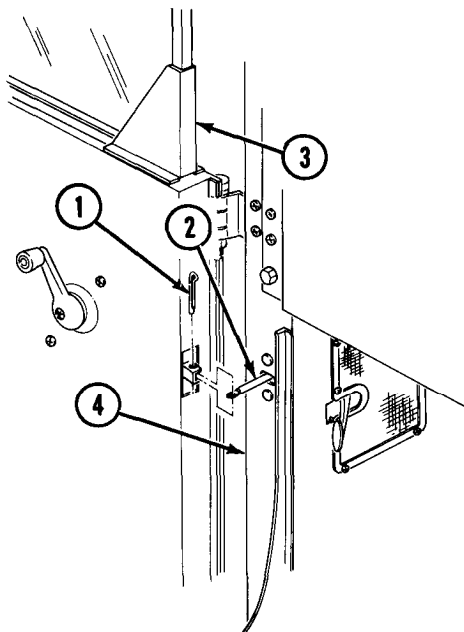

**11-9. CAB DOOR CATCH REPLACEMENT**

This task covers:

**a. Removal**

**b. Installation**

INITIAL SETUP:

**APPLICABLE MODELS**

All

**REFERENCES (TM)**

TM 9-2320-361-10

TM 9-2320-36 1-20P

**MATERIALS/PARTS**

Two screw-assembled washers

**EQUIPMENT CONDITION**

Parking brake set (TM 9-2320-361-10).

**a. Removal**

Remove two screw-assembled washers (3) and cab door catch (1) from cab body (2). Discard screw-assembled washers (3).

**b. Installation**

Install cab door catch (1) on cab body (2) with two new screw-assembled washers (3).

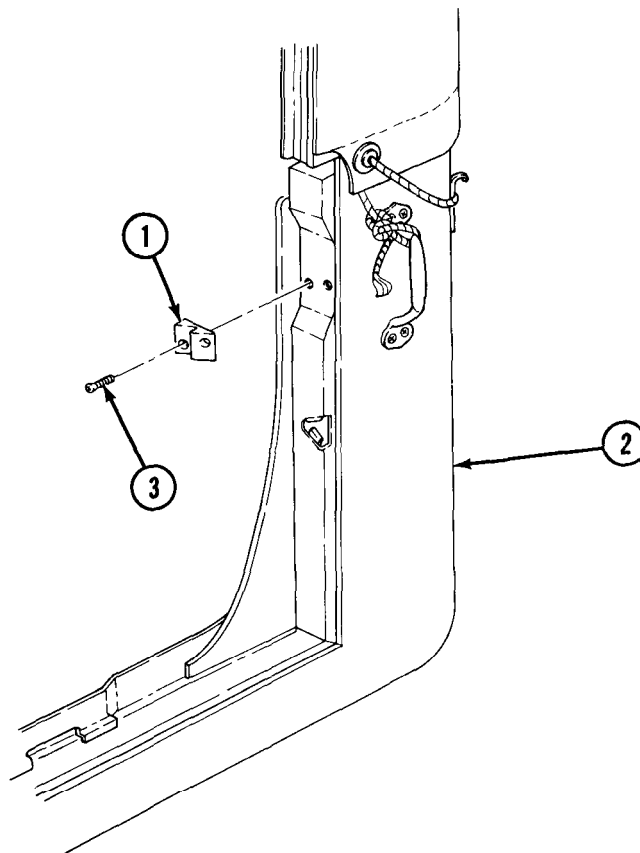

## 11-10. CAB DOOR WEATHERSEALS REPLACEMENT

This task covers:

- |   |  |
|---|--|
| a. Cab Door Weatherseals Removal              | d. Cab Door Pillar Posts Weatherseals Installation |
| b. Cab Door Head Weatherseal Removal          | e. Cab Door Head Weatherseal Installation          |
| c. Cab Door Pillar Posts Weatherseals Removal | f. Cab Door Weatherseals Installation              |

### INITIAL SETUP:

#### APPLICABLE MODELS

All

#### MATERIALS/PARTS

Adhesive (Appendix C, Item 3)

#### REFERENCES (TM)

TM 9-2320-361-10

TM 9-2320-361-20P

#### EQUIPMENT CONDITION

Parking brake set (TM 9-2320-361-10).

### a. Cab Door Weatherseals Removal

1. Remove five screws (12), clips (11), and cab door weatherseal (13) from cab door (14).
2. Remove cab door weatherseal (10) from cab door (14) and clean weatherseal (10) remains from cab door (14).

### b. Cab Door Head Weatherseal Removal

1. Remove cab door head weatherseal (4) from retainer (3).
2. Remove nine screws (2) and retainer (3) from cab soft top post (6).

### c. Cab Door Pillar Posts Weatherseals Removal

1. Remove pillar post weatherseals (7), (15), and (8) from retainers (17), (1), and (5).
2. Remove twelve screws (9) and (16) and retainers (1), (5), and (17) from pillar post (18) and cab soft top post (6).

### d. Cab Door Pillar Posts Weatherseals Installation

1. Install retainers (1), (5), and (17) on pillar post (18) and cab soft top post (6) with twelve screws (9) and (16).
2. Install pillar post weatherseals (7), (15), and (8) on retainers (17), (1), and (5).

### e. Cab Door Head Weatherseal Installation

1. Install retainer (3) on cab soft top post (6) with nine screws (2).
2. Install cab door head weatherseal (4) on retainer (3).

**11-10. CAB DOOR WEATHERSEALS REPLACEMENT (Contd]****f. Cab Door Weatherseals Installation**

1. Apply adhesive to mounting side of cab door weatherseal (13) and cab door (14) mounting surface.
2. Install cab door weatherseal (13) on cab door (14) with five screws (12) and clips (11).
3. Apply adhesive to mounting side of cab door weatherseal (10) and cab door (14) mounting surface.
4. Install cab door weatherseal (10) on cab door (14).

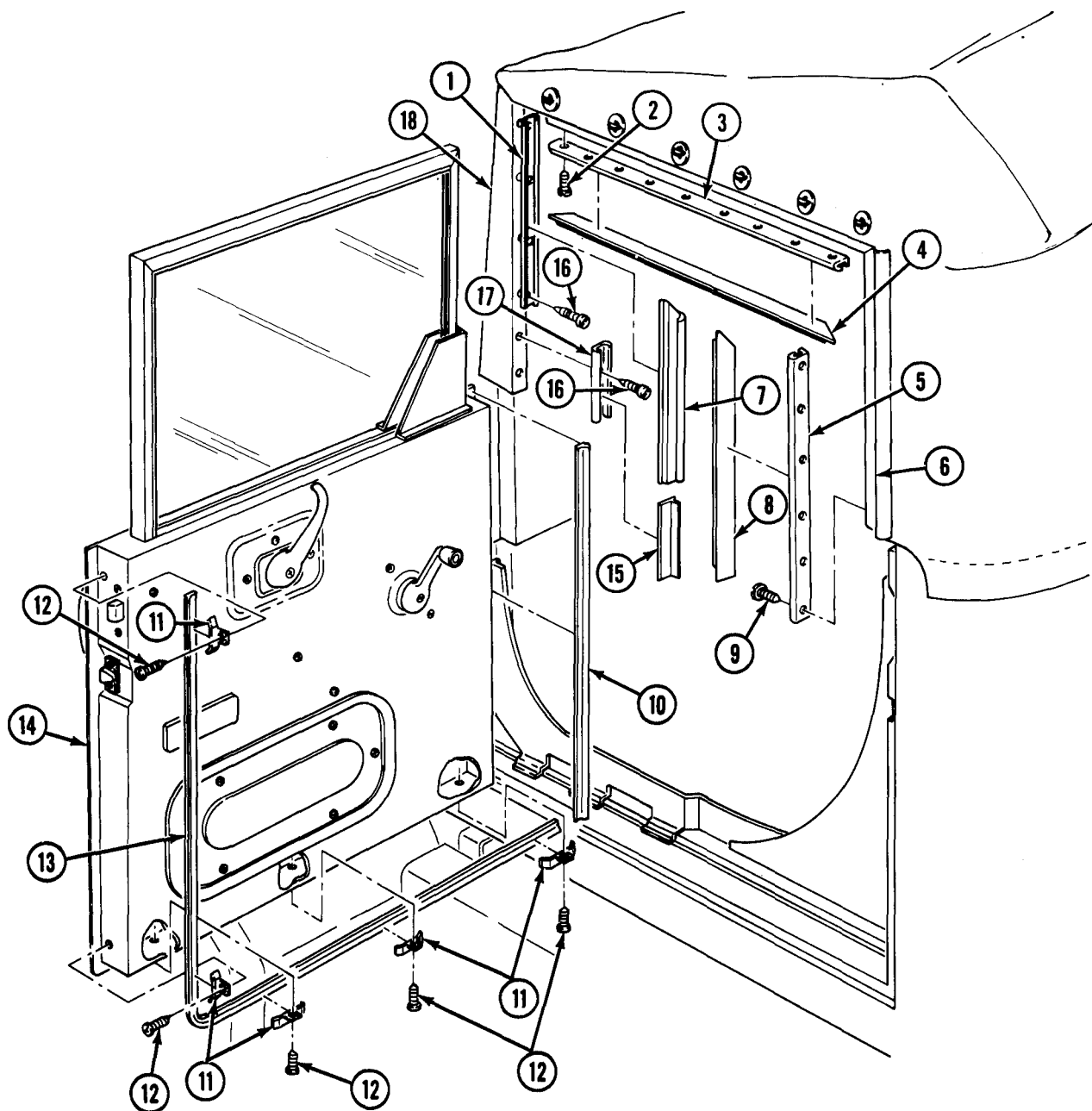



## 11-11. SIDE PANEL REPLACEMENT

This task covers:

- |  |   |
|--|---|
| <ul style="list-style-type: none"> <li>a. Side Panel Removal</li> <li>b. Side Panel Hinges Removal</li> <li>c. Thumb Cranks Removal</li> </ul> | <ul style="list-style-type: none"> <li>d. Side Panel Hinges Installation</li> <li>e. Side Panel Installation</li> <li>f. Thumb Cranks Installation</li> </ul> |
|--|---|

APPLICABLE MODELS

All

MATERIAL/IPARTS

Twelve locknuts

REFERENCES (TM)

TM 9-2320-361-10  
 TM 9-2320-361-20P

EQUIPMENT CONDITION

Parking brake set (TM 9-2320-361-10).  
 Hood raised and secured (TM 9-2320-361-10).

**NOTE**

The right side panel replacement differs from the left. The right side panel replacement requires removal of the rain hood. This procedure covers right side panel replacement.

**a. Side Panel Removal**

1. Loosen clamp (15) and remove rainhood (17) from air intake (16).
2. Turn thumb cranks (2) to unlock side panel (4) from fender (9).
3. Raise spring clip (7) and remove side panel (4) from fender (9) by sliding side panel (4) forward until free from vehicle.

**b. Side Panel Hinges Removal**

1. Remove four locknuts (5), washers (6), screws (14), spring clip (7), and two hinges (8) from side panel (4). Discard locknuts (5).
2. Remove four locknuts (11), washers (10), screws (13), and two hinges (12) from fender (9). Discard locknuts (11).

**c. Thumb Cranks Removal**

**NOTE**

Perform steps 1 and 2 if side panel has not been removed.

1. Loosen clamp (15) and remove rainhood (17) from air intake (16).
2. Turn thumb cranks (2) to unlock side panel (4) from fender (9).
3. Remove four locknuts (3), screws (1), and two thumb cranks (2) from side panel (4). Discard locknuts (3).

**d. Side Panel Hinges Installation**

1. Install two hinges (12) on fender (9) with four screws (13), washers (10), and new locknuts (11).
2. Install two hinges (8) and spring clip (7) on side panel (4) with four screws (14), washers (6), and new locknuts (5).

## 11-11. SIDE PANEL REPLACEMENT (Contd)

### e. Side Panel Installation

1. With hinges (8) and (12) alined, raise spring clip (7), and install side panel (4) on fender (9) by sliding side panel (4) to the rear until in place.
2. Lock side panel (4) to fender (9) by turning thumb cranks (2).
3. Install rain hood (17) on air intake (16) with clamp (15).

### f. Thumb Cranks Installation

1. Install two thumb cranks (2) on side panel (4) with four screws (1) and new locknuts (3).

#### NOTE

Perform steps 2 and 3 if side panel was removed.

2. Lock side panel (4) to fender (9) by turning thumb cranks (2).
3. Install rainhood (17) on air intake (16) with clamp (15).

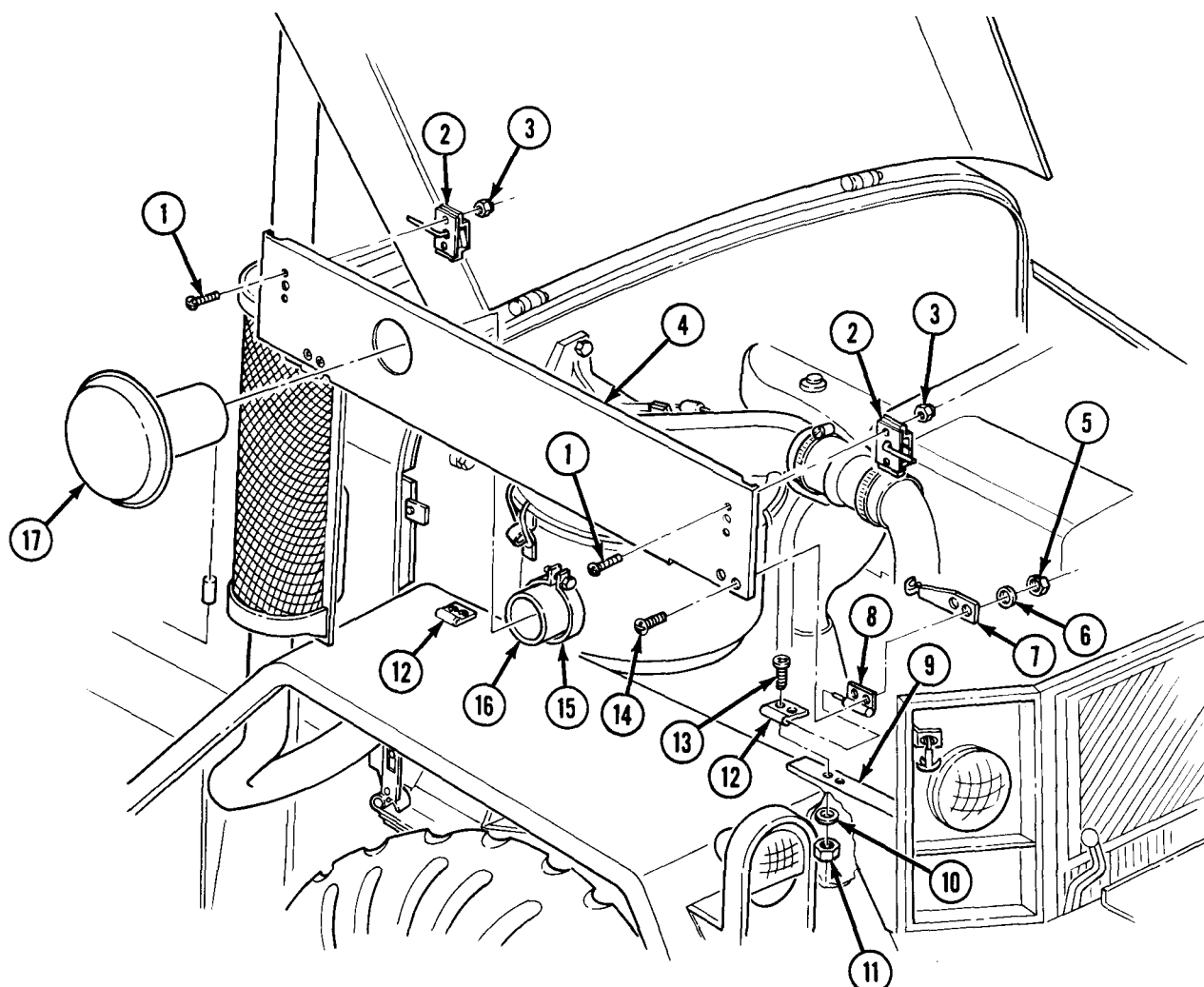

## 11-12. HEADLIGHT BRACKET REPLACEMENT

This task covers:

### a. Removal

### b. Installation

INITIAL SETUP:

#### APPLICABLE MODELS

All

#### REFERENCES (TM)

TM 9-2320-361-10

#### EQUIPMENT CONDITION

- Brush guard removed (para. 10-8).
- Sealed beam and headlight housing removed (para. 4-39).
- Blackout drive lamp and housing removed (para. 4-42).

### a. Removal

1. Remove two screws (5), washers (4), and brace (7) from front fender (1) and headlight bracket (9).
2. Remove three nuts (15), washers (14) and (11), and screws (10) from headlight bracket (9).
3. Remove two nuts (16), washers (17), and screws (6) from front hinge (2) and side panel (3).
4. Remove two nuts (13), washers (12), screws (8), and headlight bracket (9) from front fender (1).

### b. Installation

1. Install headlight bracket (9) on front fender (1) with two nuts (13), washers (12), and screws (8).
2. Install front hinge (2) on side panel (3) with two nuts (16), washers (17), and screws (6).
3. Install headlight bracket (9) on front fender (1) with three nuts (15), washers (14) and (11), and screws (10).
4. Install brace (7) on headlight bracket (9) and front fender (1) with two washers (4) and screws (5).

## 11-12. HEADLIGHT BRACKET REPLACEMENT (Contd)

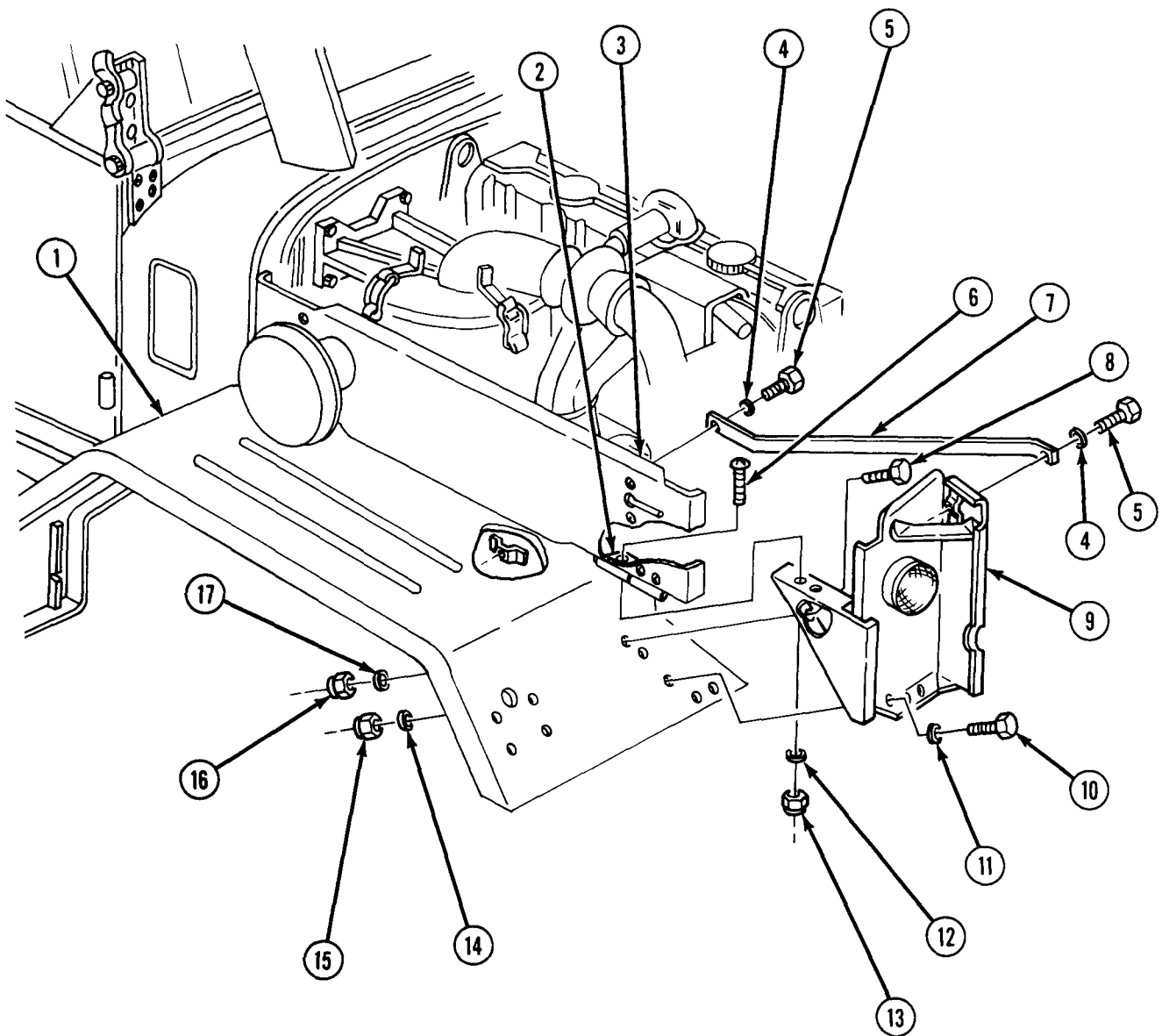

- FOLLOW-ON TASKS:
- Install brushguard (para. 10-8).
  - Install sealed beam and headlight housing (para. 4-39).
  - Install blackout drive lamp and housing (para. 4-42).

## 11-13. HOOD FASTENERS REPLACEMENT

This task covers:

- |  |   |
|--|---|
| <ul style="list-style-type: none"> <li>a. Hood Holddown Fastener and Bracket Removal</li> <li>b. Safety Latch Removal</li> <li>c. Hood Support Hook Removal</li> </ul> | <ul style="list-style-type: none"> <li>d. Hood Support Hook Installation</li> <li>e. Safety Latch Installation</li> <li>f. Hood Holddown Fastener and Bracket Installation</li> </ul> |
|--|---|

INITIAL SETUP:

APPLICABLE MODELS

All

MATERIALS/PARTS

Eight locknuts

REFERENCES (TM)

TM 9-2320-361-10

TM 9-2320-361-20P

EQUIPMENT CONDITION

Parking brake set (TM 9-2320-361-10).

**NOTE**

Hood holddown, companion seat fastener, fastener and windshield holddown fasteners are replaced basically the same. Some fasteners have additional hardware and reinforcements. This procedure covers the hood holddown fastener only.

### a. Hood Holddown Fastener and Bracket Removal

1. Unlatch fastener (15) from bracket (13).
2. Raise and secure hood (10).
3. Remove two locknuts (11), screws (16), and fastener (15) from brush guard (17) Discard locknuts (11).
4. Remove two locknuts (12), screws (14), and bracket (13) from hood (10). Discard locknuts (12).

### b. Safety Latch Removal

Remove two locknuts (20), screws (18), and safety latch (19) from hood (10). Discard locknuts (20).

### c. Hood Support Hook Removal

1. Lower hood (10).
2. Remove hook (7) from clip (9).
3. Remove screw (8) and clip (9) from cowling (1).
4. Remove locknut (3), washer (4), nut (6), and hook (7) from bolt (5). Discard locknut (3).
5. Remove locknut (2) and bolt (5) from cowling (1). Discard locknut (2).

### d. Hood Support Hook Installation

1. Install nut (6), bolt (5), washer (4), and new locknut (3) on hook (7). Install assembled hook (7) on cowling (1) with new locknut (2).
2. Install clip (9) on cowling (1) with screw (8).
3. Install hook (7) on clip (9).

**11-13. HOOD FASTENERS REPLACEMENT (Contd)**

**e. Safety Latch Installation**

1. Raise and secure hood (10).
2. Install safety latch (19) on hood (10) with two screws (18) and new locknuts (20).

**f. Hood Holddown Fastener and Bracket Installation**

1. Install bracket (13) on hood (10) with two screws (14) and new locknuts (12).
2. Install fastener (15) on brush guard (17) with two screws (16) and new locknuts (11).
3. Lower and secure hood (10).
4. Latch fastener (15) on bracket (13).

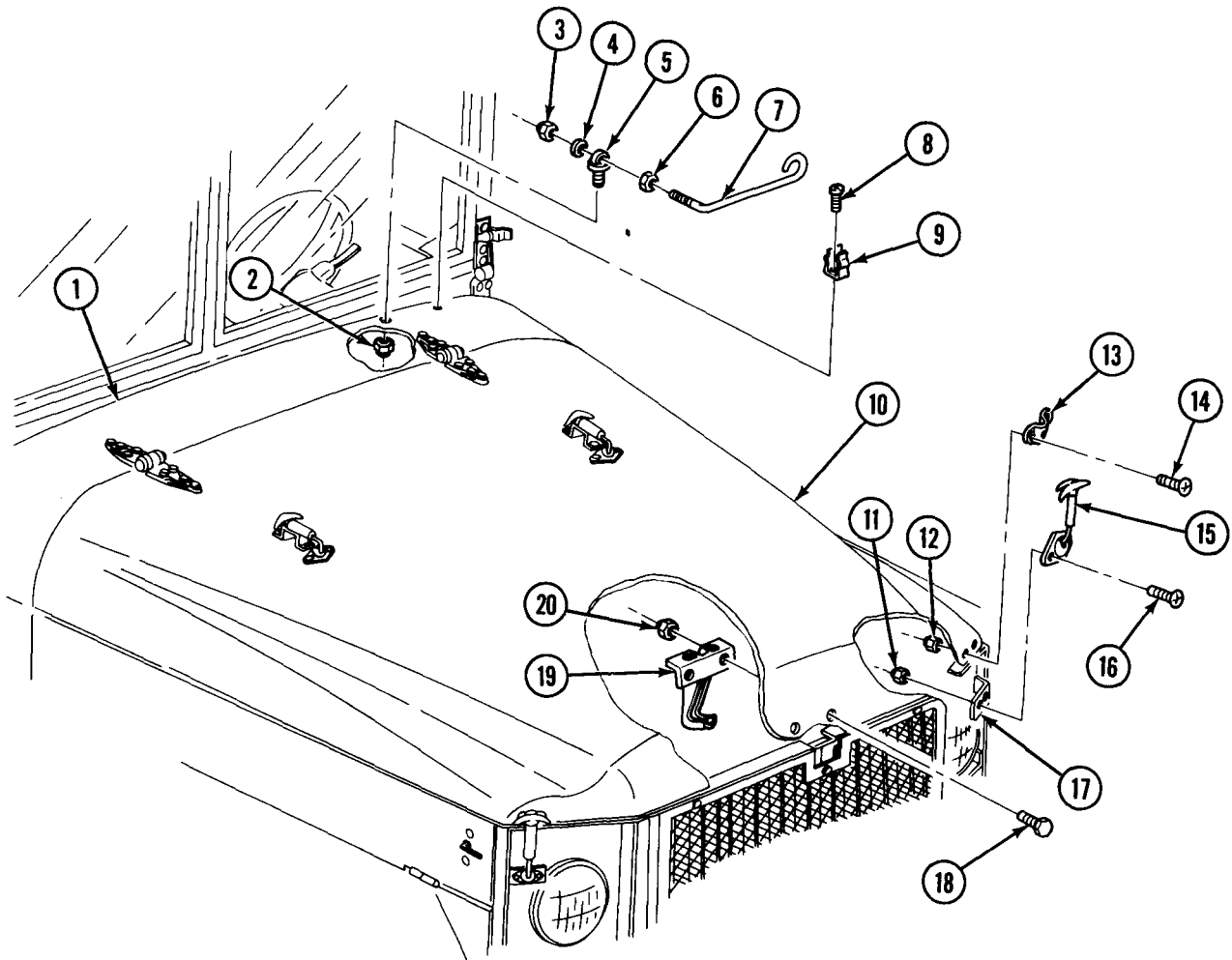

<b>11-14. HOOD MAINTENANCE</b>
--------------------------------

This task covers:

- a. Removal**
- b. Repair**

- c. Installation**

**INITIAL SETUP**

APPLICABLE MODELS

All

MATERIALS/PARTS

Eight locknuts  
 Eight split rivets  
 Adhesive (Appendix C, Item 1)

PERSONNEL REQUIRED

Two

REFERENCES (TM)

TB 43-0209  
 TC 9-510  
 T M 9 - 2 3 7  
 TM 9-2320-361-10  
 TM 9-2320-361-20P

EQUIPMENT CONDITION

- Parking brake set (TM 9-2320-361-10).
- Hood holddown fasteners and brackets removed (para. 11-13).
- Windshield holddown fasteners and brackets removed (para. 11-20).

<b>a. Removal</b>
-------------------

1. Raise hood (5) and remove eight split rivets (7) and two rubber bumpers (6) from hood (5). Discard split rivets (7).

**NOTE**

Assistant will help with step 2.

2. Remove eight locknuts (4), two reinforcements (3), eight screws (1), and hood (5) from two hinges (2). Discard locknuts (4).
3. Remove adhesive remains from hood.

1. Refer to TM 9-237 for welding repair.
2. Refer to TC 9-510 for metal body repair.
3. Refer to TB 43-0209 for rustproofing instructions.

<b>c. Installation</b>
------------------------

**NOTE**

Assistant will help with step 1.

1. Install hood (5) on two hinges (2) with two reinforcements (3), eight screws (1), and new locknuts (4).
2. Apply adhesive to rubber bumpers (6).
3. Install two rubber bumpers (6) on hood (5) with eight new split rivets (7).

11-14. HOOD MAINTENANCE (Contd)

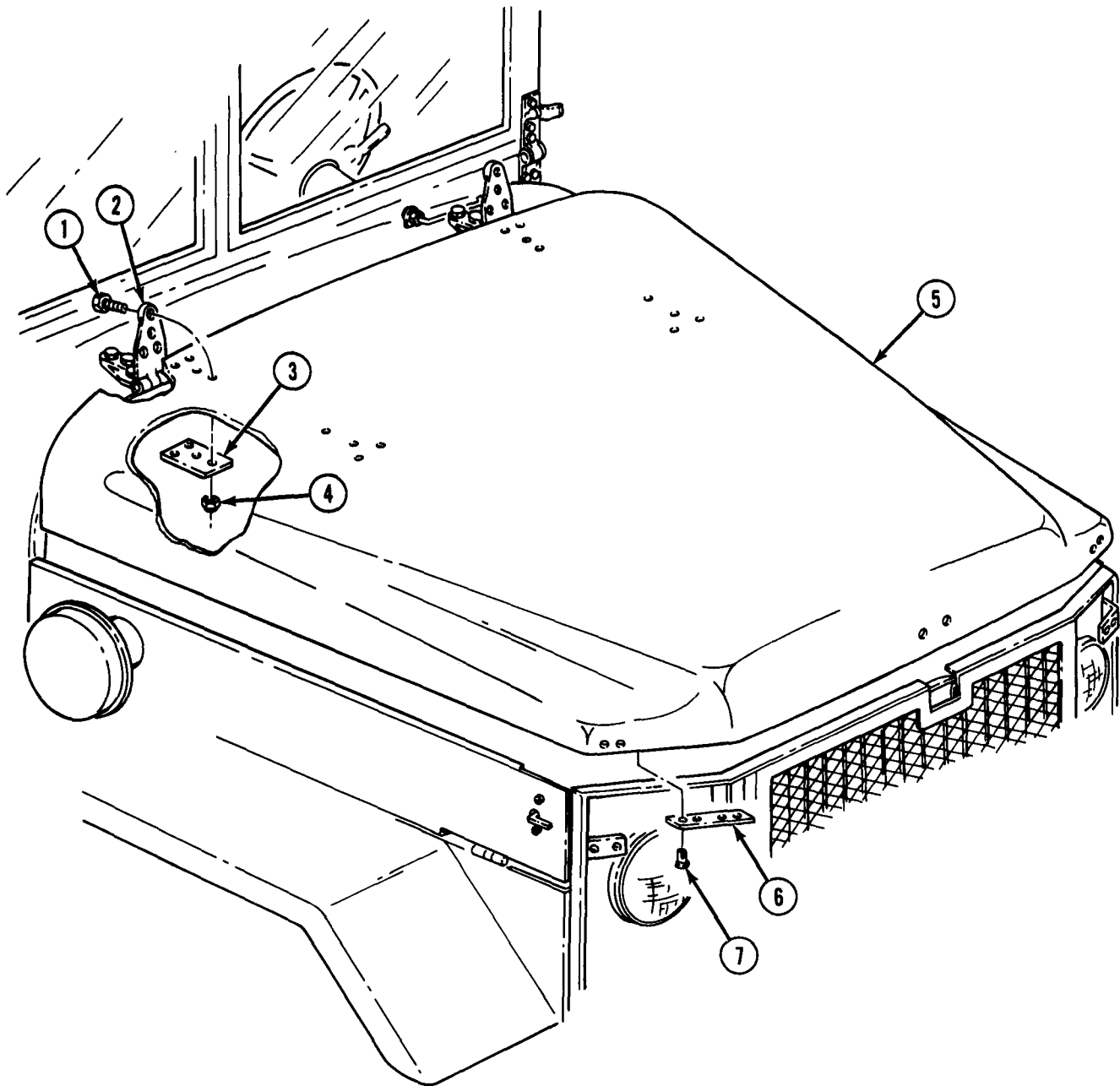

- FOLLOW-ON TASKS:
- Install windshield holddown fasteners and brackets (para. 11-20).
  - Install hood holddown fasteners and brackets (para. 11-13).



# 11-15. HOOD HINGES REPLACEMENT

This task covers:

**a. Removal**

**b. Installation**

**INITIAL SETUP:**

APPLICABLE MODELS

All

REFERENCES (TM)

TM 9-2320-361-10  
 TM 9-2320-361-20P

MATERIALS/PARTS

Eight locknuts

EQUIPMENT CONDITION

- Parking brake set (TM 9-2320-361-10).
- Hood raised and secured (TM 9-2320-361-10).
- Glove compartment removed (para. 11-18).

PERSONNEL REQUIRED

Two

GENERAL SAFETY INSTRUCTIONS

Keep fingers clear when replacing hinge.

**WARNING**

Keep fingers clear of hood and cowling when replacing hinge. Failure to do so may result in injury to personnel.

**a. Removal**

**NOTE**

Assistant will help with step 1.

1. Remove four locknuts (7), reinforcement (8), and four screws (1) from hinge (9) and cowling (3). Discard locknuts (7).
2. Remove four locknuts (5), reinforcement (6), four screws (2), and hinge (9) from hood (4) and cowling (3). Discard locknuts (5).

**b. Installation**

1. Install hinge (9) and reinforcement (6) to hood (4) with four screws (2) and new locknuts (5).

**NOTE**

Assistant will help with step 2.

2. Install hinge (9) and reinforcement (8) to cowling (3) with four screws (1) and new locknuts (7).

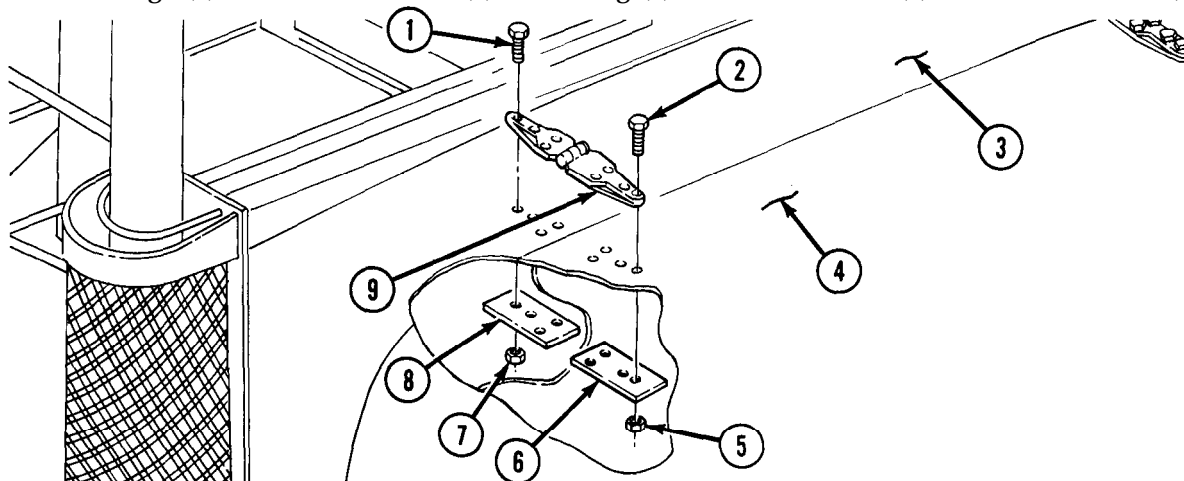

**FOLLOW-ON TASK:** Install glove compartment (para. 11-18).

## 11-16. CAB HANDLE REPLACEMENT

This task covers:

### a. Removal

### b. Installation

INITIAL SETUP:

#### APPLICABLE MODELS

All

#### MATERIALS/PARTS

Four locknuts

#### REFERENCES (TM)

TM 9-2320-361-10

TM 9-2320-361-20P

#### EQUIPMENT CONDITION

Parking brake set (TM 9-2320-361-10).

### a. Removal

1. Remove soft top rope (2) from cab handle (4).
2. Remove four screws (5), locknuts (6), plate (1), and cab handle (4) from cab (3). Discard locknuts (6).

### b. Installation

1. Install cab handle (4) and plate (1) on cab (3) with four screws (5) and new locknuts (6).
2. Tie soft top rope (2) on cab handle (4).

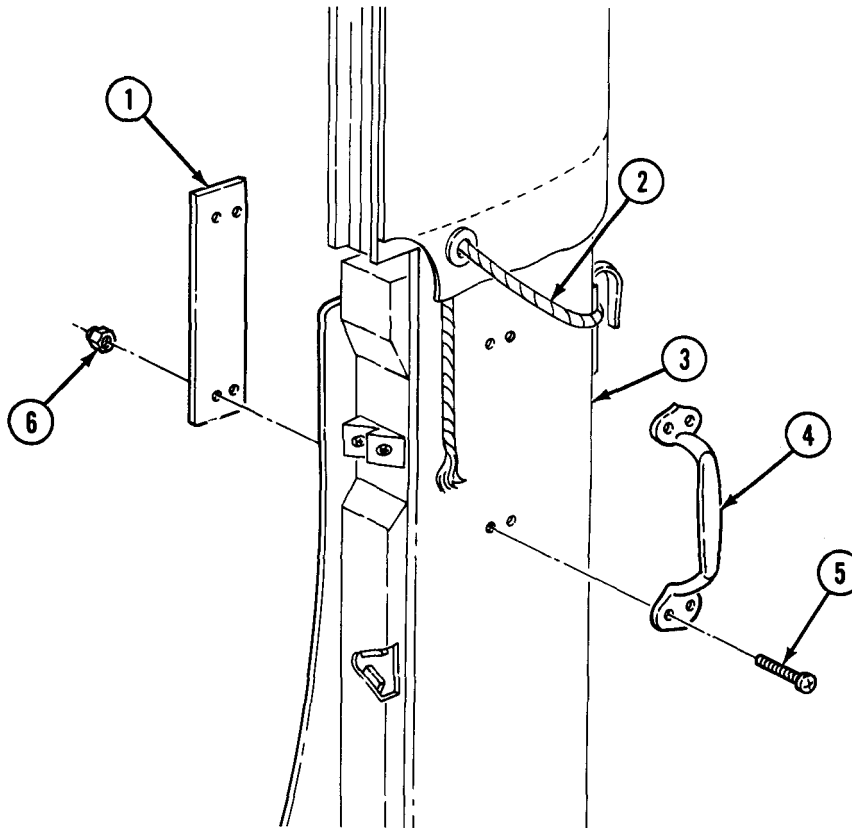

## 11-17. CAB COWL VENT REPLACEMENT

This task covers:

### a. Removal

### b. Installation

INITIAL SETUP:

#### APPLICABLE MODELS

All

#### MATERIALS/PARTS

Cotter pin  
Adhesive (Appendix C, Item 2)

#### REFERENCES (TM)

TM 9-2320-361-10  
TM 9-2320-361-20P

#### EQUIPMENT CONDITION

Parking brake set (TM 9-2320-361-10).

### a. Removal

1. Remove nine screws (4) and cowl vent screen (5) from kick panel (1).
2. Remove cotter pin (8), hinge pin (3), and cab cowl vent door (6) from bracket (2). Discard cotter pin (8).
3. Inspect cab cowl vent door seal (7). If damaged, clean cab cowling seal mounting surface (9) free of cab cowl vent seal (7) debris.

### b. Installation

#### NOTE

Perform steps 1 and 2 only if seal was removed.

1. Apply adhesive to mounting side of seal (7) and cab cowling seal mounting surface (9).
2. Install cab cowl vent seal (7) on cab cowling seal mounting surface (9).
3. Install cab cowl vent door (6) and hinge pin (3) on bracket (2) with new cotter pin (8).
4. Install cab cowl vent screen (5) on kick panel (1) with nine screws (4).

11-17. CAB COWL VENT REPLACEMENT (Contd)

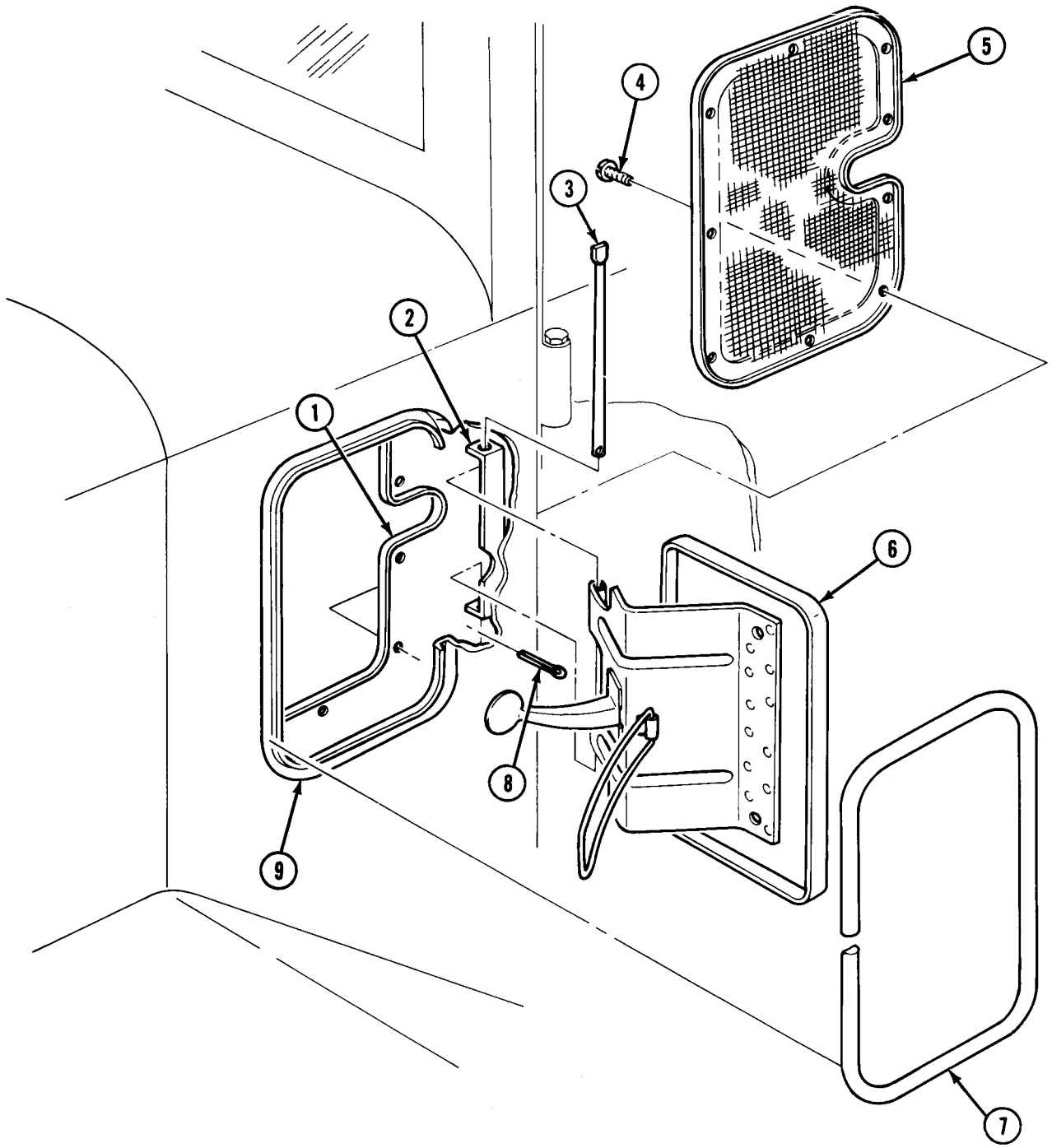

## 11-18. GLOVE COMPARTMENT REPLACEMENT

This task covers:

### a. Removal

### b. Installation

INITIAL SETUP:

#### APPLICABLE MODELS

All

#### MATERIALS/PARTS

Adhesive (Appendix C, Item 2)

#### REFERENCES (TM)

TM 9-2320-361-10

TM 9-2320-361-20P

#### EQUIPMENT CONDITION

Parking brake set (TM 9-2320-361-10).

### a. Removal

1. Remove two screws (2) and bracket (3) from instrument panel (4).
2. Remove ten screws (9) and glove compartment (1) from instrument panel (4).
3. Remove four nuts (5), screws (7), and glove compartment door (6) from instrument panel (4).

#### NOTE

Perform step 4 if glove compartment door is damaged.

4. Inspect glove compartment door seal (8). If damaged, clean glove compartment door (6) seal mounting surface free of seal (8) debris.

### b. Installation

#### NOTE

Perform steps 1 and 2 only if seal was removed.

1. Apply adhesive to glove compartment door (6) seal mounting surface and mounting side of seal (8).
2. Install seal (8) on glove compartment door (6).
3. Install bracket (3) on instrument panel (4) with two screws (2).
4. Install glove compartment door (6) on instrument panel (4) with four screws (7) and nuts (5).
5. Install glove compartment (1) on instrument panel (4) with ten screws (9).

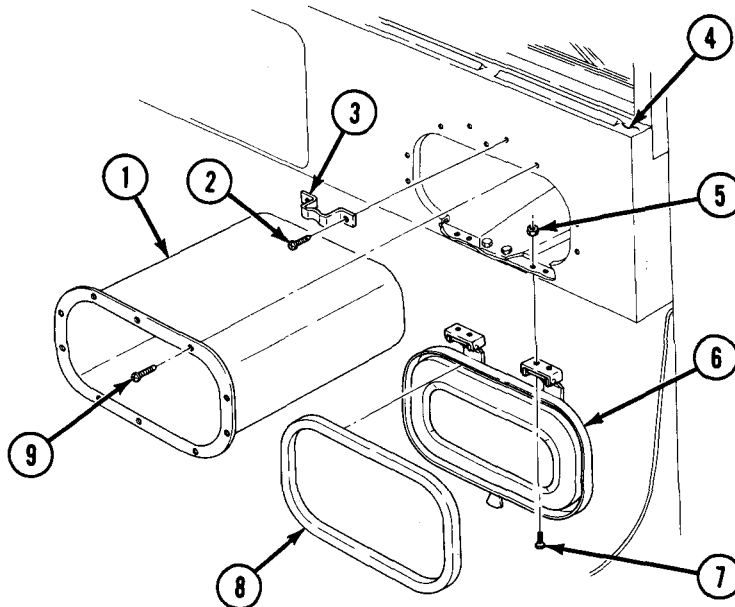

## 11-19. TOOLBOX (UNDER CAB) REPLACEMENT

This task covers:

### a. Removal

### b. Installation

INITIAL SETUP:

#### APPLICABLE MODELS

All

#### MATERIALS/PARTS

Eighteen locknuts

#### REFERENCES (TM)

TM 9-2320-361-10

TM 9-2320-361-20P

#### EQUIPMENT CONDITION

- Parking brake set (TM 9-2320-261-10).
- Water can bracket and running board removed (para. 11-24).

### a. Removal

Remove eighteen locknuts (3), screws (4), and toolbox (1) from two supports (2). Discard locknuts (3).

### b. Installation

Install toolbox (1) on two supports (2) with eighteen screws (4) and new locknuts (3).

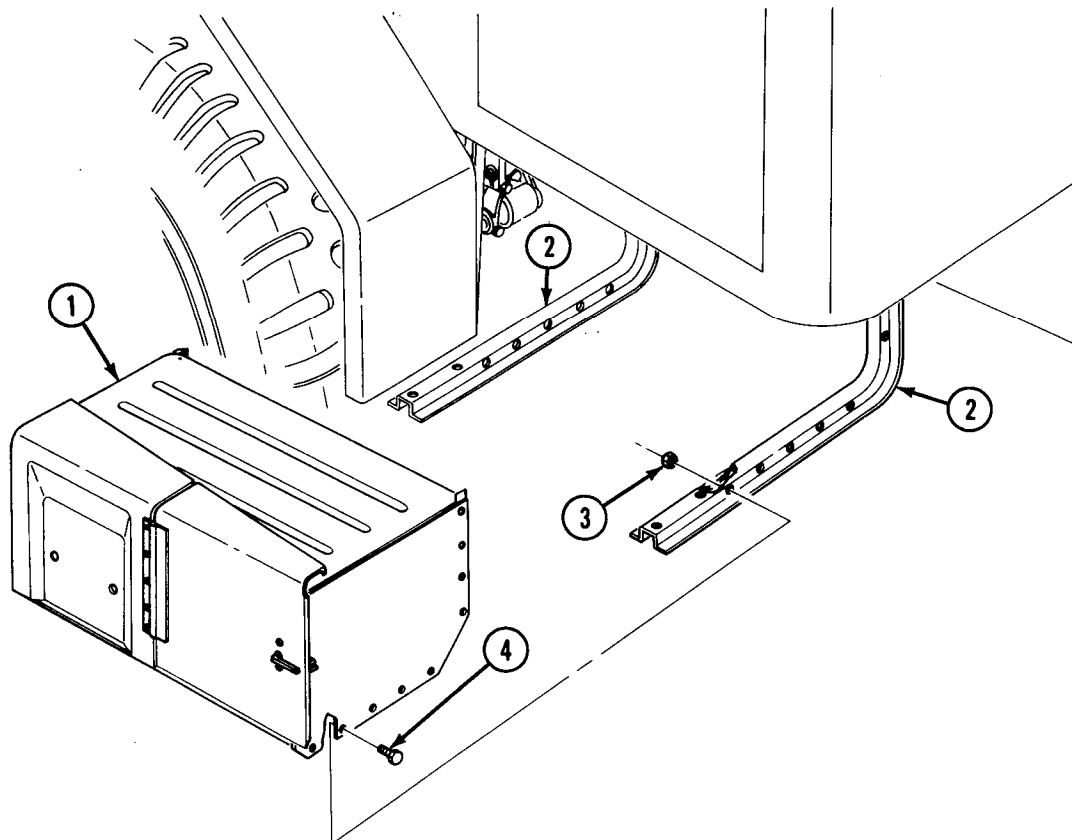

FOLLOW-ON TASK: Install water can bracket and running board (para. 11-24).

**11-20. WINDSHIELD ASSEMBLY MAINTENANCE**

This task covers:

- a. Removal
- b. Disassembly

- c. Assembly
- d. Installation

**INITIAL SETUP:**

APPLICABLE MODELS

All

MATERIALS/PARTS

Three lockwashers  
 Two locknuts  
 Eighteen screw-assembled lockwashers  
 Three weatherstrips  
 Adhesive (Appendix C, Item 2)

REFERENCES (TM)

TM 9-2320-361-10  
 TM 9-2320-361-20P

EQUIPMENT CONDITION

- Parking brake set (TM 9-2320-361-10).
- Soft top removed (TM 9-2320-361-10).
- Wiper motors removed (para. 11-34).

**a. Removal**

**NOTE**

Perform steps 1 through 3 for vehicles equipped with hardtop kit.

1. Remove two screws (8) and lockwashers (7) from cab hardtop (6) and windshield frame (5). Discard lockwashers (7).
2. Remove two screws (2), washers (3), and locknuts (4) from cab hardtop (6) and windshield frame (5). Discard locknuts (4).
3. Loosen two knobs (11).

**NOTE**

- Two lower hinges are attached to cab by six screw-assembled lockwashers. Exhaust support is attached to lower right hinge and cab by a longer screw and lockwasher.
  - Assistant will help with step 4.
4. Remove six screw-assembled lockwashers (21) and windshield frame (5) from left (22) and right (24) upper hinges and cab (9). Discard screw-assembled lockwashers (21).
  5. Remove six screw-assembled lockwashers (18) and lower left hinge (17) from cab (9). Discard screw-assembled lockwashers (18).
  6. Remove six screw-assembled lockwashers (27) from lower right hinge (23) and cab (9). Discard screw-assembled lockwashers (27).
  7. Remove screw (26), lockwasher (25), and lower right hinge (23) from exhaust support (28) and cab (9). Discard lockwasher (25).
  8. Remove four screws (10) and two brackets (15) from windshield frame (5).
  9. Remove four screws (14), two plates (13), and weatherstrips (12) from two brackets (15). Discard weatherstrips (12).
  10. Remove weatherstrip (1) from windshield frame (5). Discard weatherstrip (1). Clean windshield frame (5) free of all weatherstrip (1) remains.

**b. Disassembly**

1. Remove knob (11) and stud (20) from upper left hinge (22).
2. Remove nut (19), hinge bolt (16), and upper left hinge (22) from lower left hinge (17).

11-20. WINDSHIELD ASSEMBLY MAINTENANCE (Contd)

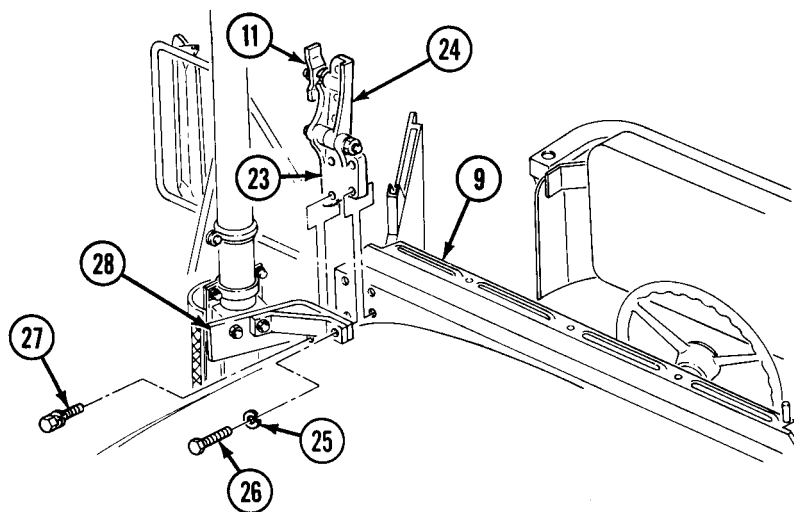
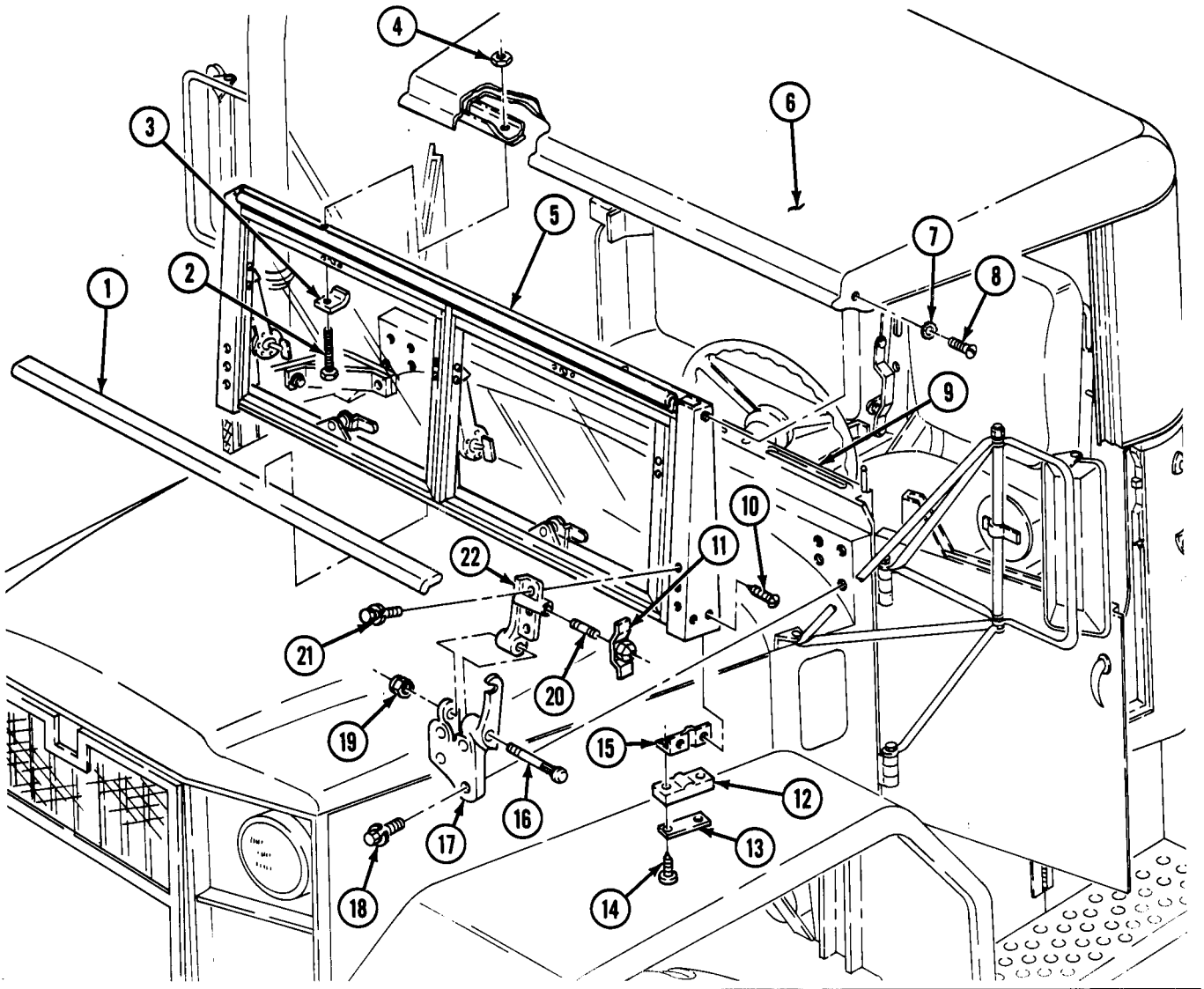



## 11-20. WINDSHIELD ASSEMBLY MAINTENANCE (Contd)

### c. Assembly

1. Install upper left hinge (22) on lower left hinge (17) with hinge bolt (16) and nut (19).
2. Install stud (20) and knob (11) in upper left hinge (22). Do not tighten knobs (11) if vehicle is equipped with hardtop kit.

### d. Installation

1. Apply adhesive to mounting side of new weatherstrip (1) and windshield frame (5) mounting surface. Install weatherstrip (1) on windshield frame (5) mounting surface.
2. Install two new weatherstrips (12) and plates (13) on two brackets (15) with four screws (14).
3. Install two brackets (15) on windshield frame (5) with four screws (10).

#### NOTE

Two lower hinges are attached to cab by six screw-assembled lockwashers. Exhaust support is attached to lower right hinge and cab by a longer screw and lockwasher.

Assistant will help with step 4.

4. Install windshield frame (5) in place on cab (9) and install hinges (22) and (24) on windshield frame (5) with six new screw-assembled lockwashers (21).
5. Install lower right hinge (23) on exhaust support (28) and cab (9) with new lockwasher (25) and screw (26).
6. Install lower right hinge (23) on cab (9) with six new screw-assembled lockwashers (27).

#### NOTE

Perform steps 7 through 9 on vehicles equipped with hardtop kit.

7. Tighten knobs (11) against hinges (22) and (24).
8. Install cab hardtop (6) on windshield frame (5) with two screws (2), washers (3), and new lock-nuts (4).
9. Install cab hardtop (6) on windshield frame (5) with two screws (8) and new lockwashers (7).

11-20. WINDSHIELD ASSEMBLY MAINTENANCE (Contd)

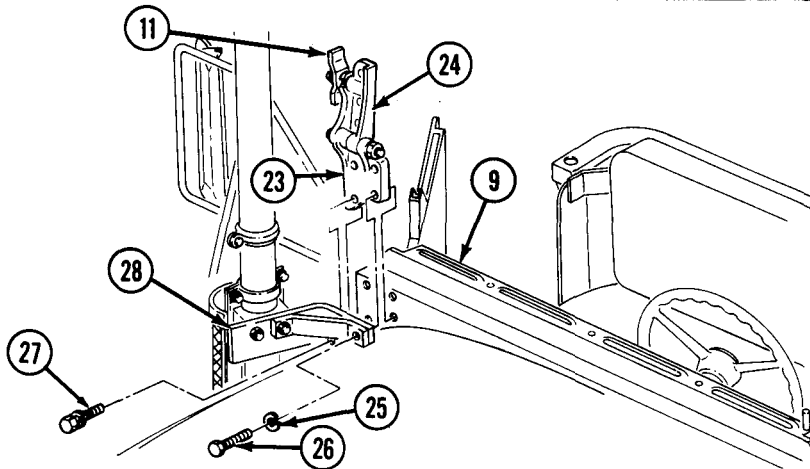
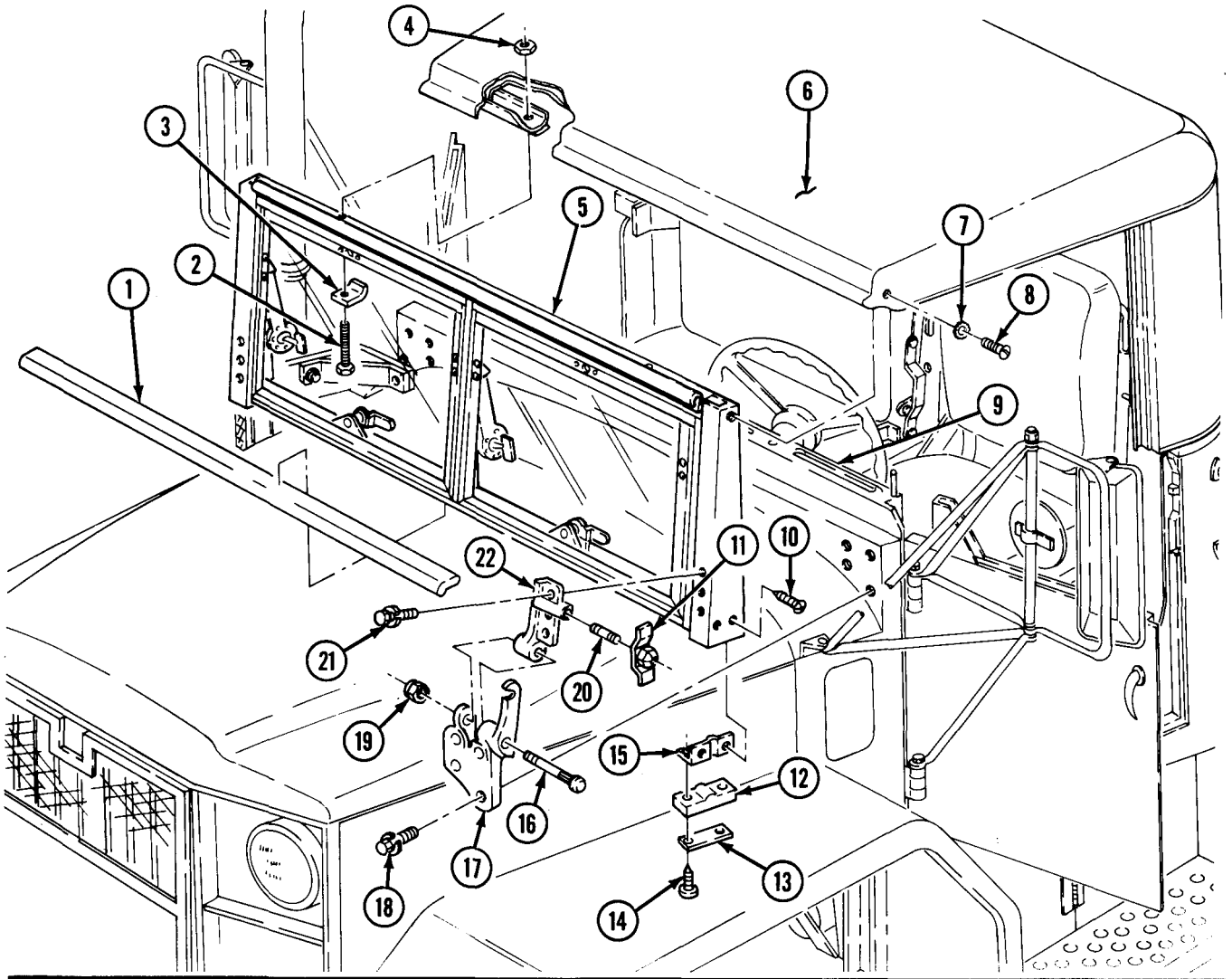

- FOLLOW-ON TASKS:
- Install wiper motor (para. 11-34).
  - Install cab soft top (TM 9-2320-361-10).

## 11-21. WINDSHIELD ARM, GLASS, AND HANDLE REPLACEMENT

This task covers:

- a. Arm Removal
- b. Glass Removal
- c. Handle Removal

- d. Handle Installation
- e. Glass Installation
- f. Arm Installation

### INITIAL SETUP:

#### APPLICABLE MODELS

All

#### MATERIALS/PARTS

Nine screw-assembled lockwashers  
 Three seals  
 Bumper  
 Adhesive (Appendix C, Item 3)

#### REFERENCES (TM)

TM 9-2320-361-10  
 TM 9-2320-361-20P

#### EQUIPMENT CONDITION

- Parking brake set (TM 9-2320-361-10).
- Wiper motors removed (para. 11-34).

### a. Arm Removal

Remove two screws (8) and spring washers (9) from arm (11), outer frame bracket (5), lever (12), and glass frame bracket (10).

### b. Glass Removal

1. Remove seven screw-assembled lockwashers (18) from windshield hinge (3) and windshield outer frame (4). Discard screw-assembled lockwashers (18).
2. Remove two hinge seals (1) and (2) from windshield hinge (3). Remove seal (13) from windshield inner frame (19). Discard seals (1), (2), and (13).

### c. Handle Removal

1. Remove two screws (17), nuts (15), and handle (14) from windshield inner frame (19).
2. Remove bumper (16) from handle (14). Discard bumper (16).
3. Remove two screw-assembled lockwashers (6) and plate (7) from windshield outer frame (4). Discard screw-assembled lockwashers (6).

### d. Handle Installation

1. Install new bumper (16) in handle (14).
2. Install handle (14) on windshield inner frame (19) with two screws (17) and nuts (15).
3. Install plate (7) on windshield outer frame (4) with two new screw-assembled lockwashers (6).

**11-21. WINDSHIELD ARM, GLASS, AND HANDLE REPLACEMENT (Contd)**

**e. Glass Installation**

1. Apply adhesive to mounting side of new hinge seals (1) and (2) and on hinge (3).
2. Install two new hinge seals (1) and (2) on hinge (3).
3. Install new seal (13) on windshield inner frame (19).
4. Install hinge (3) on windshield outer frame (4) with seven new screw-assembled lockwashers (18).
5. Install windshield inner frame (19) on hinge (3).

**f. Arm Installation**

Install arm (11) on outer frame bracket (5) and lever (12) on glass frame bracket (10) with two screws (8) and spring washers (9).

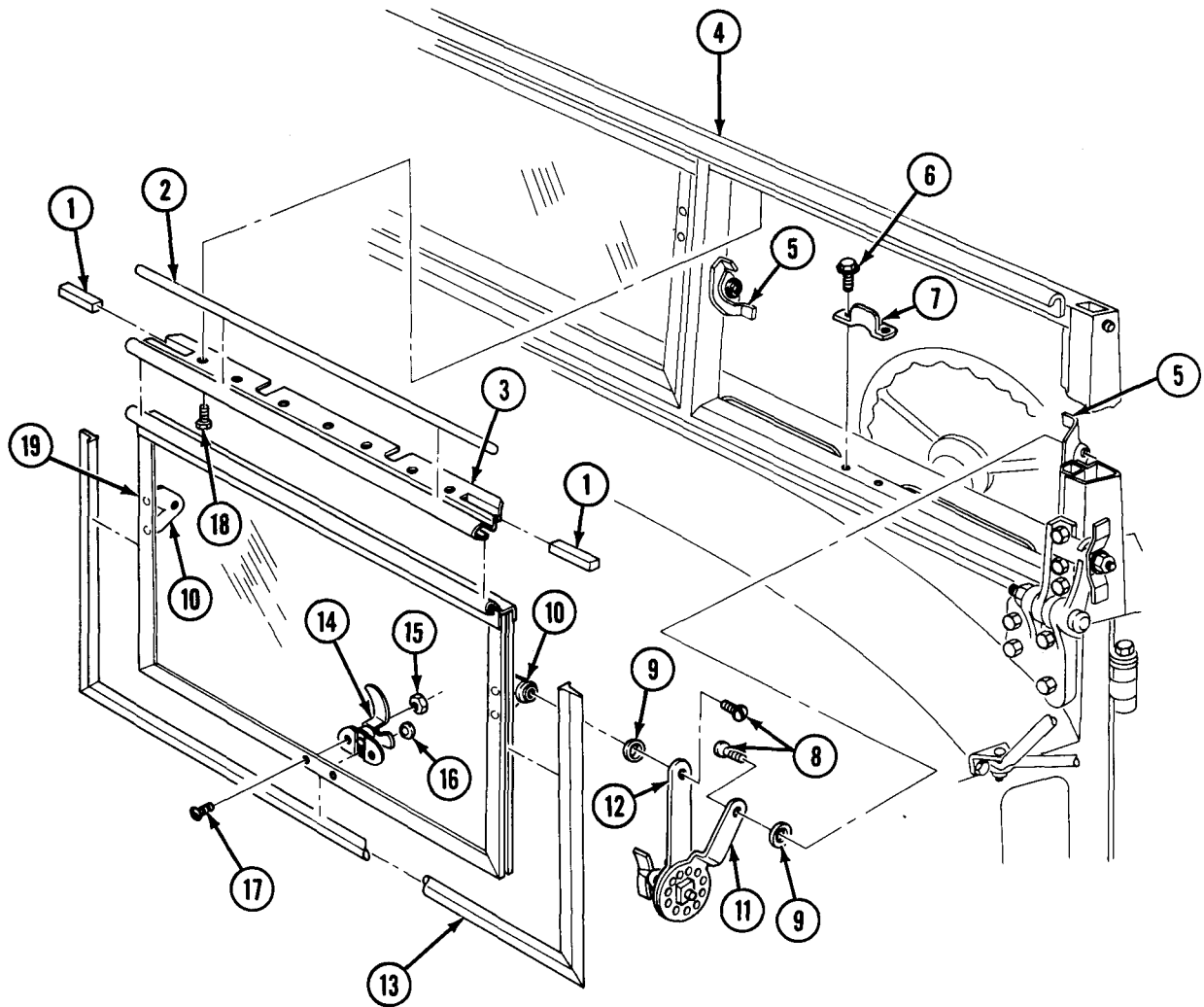

FOLLOW-ON TASK: Install wiper motor (para. 11-34).

## 11-22. CAB TUNNEL, REAR TUNNEL, AND TOEBOARD REPLACEMENT

This task covers:

- a. Tunnel Removal
- b. Rear Tunnel Removal
- c. Toeboard Removal

- d. Toeboard Installation
- e. Rear Tunnel Installation
- f. Tunnel Installation

### INITIAL SETUP:

#### APPLICABLE MODELS

All

#### MATERIALS/PARTS

Twenty-nine lockwashers

#### REFERENCES (TM)

TM 9-2320-361-10

TM 9-2320-361-20P

#### EQUIPMENT CONDITION

- Parking brake set (TM 9-2320-361-10).
- Companion seat removed (para. 11-26).

### a. Tunnel Removal

Remove thirteen screws (3), lockwashers (4), washers (5), and tunnel (2) from rear tunnel (6), toeboard (1), and cab floor (7). Discard lockwashers (4).

### b. Rear Tunnel Removal

Remove eight screws (3), lockwashers (4), washers (5), and rear tunnel (6) from cab floor (7). Discard lockwashers (4).

### c. Toeboard Removal

Remove eight screws (3), lockwashers (4), washers (5), and toeboard (1) from cab floor (7). Discard lockwashers (4).

### d. Toeboard Installation

Install toeboard (1) on cab floor (7) with eight washers (5), new lockwashers (4), and screws (3).

### e. Rear Tunnel Installation

Install rear tunnel (6) on cab floor (7) with eight washers (5), new lockwashers (4), and screws (3).

### f. Tunnel Installation

Install tunnel (2) on rear tunnel (6), toeboard (1), and cab floor (7) with thirteen washers (5), new lockwashers (4), and screws (3).

11-22. CAB TUNNEL, REAR TUNNEL, AND TOEBOARD REPLACEMENT (Contd)

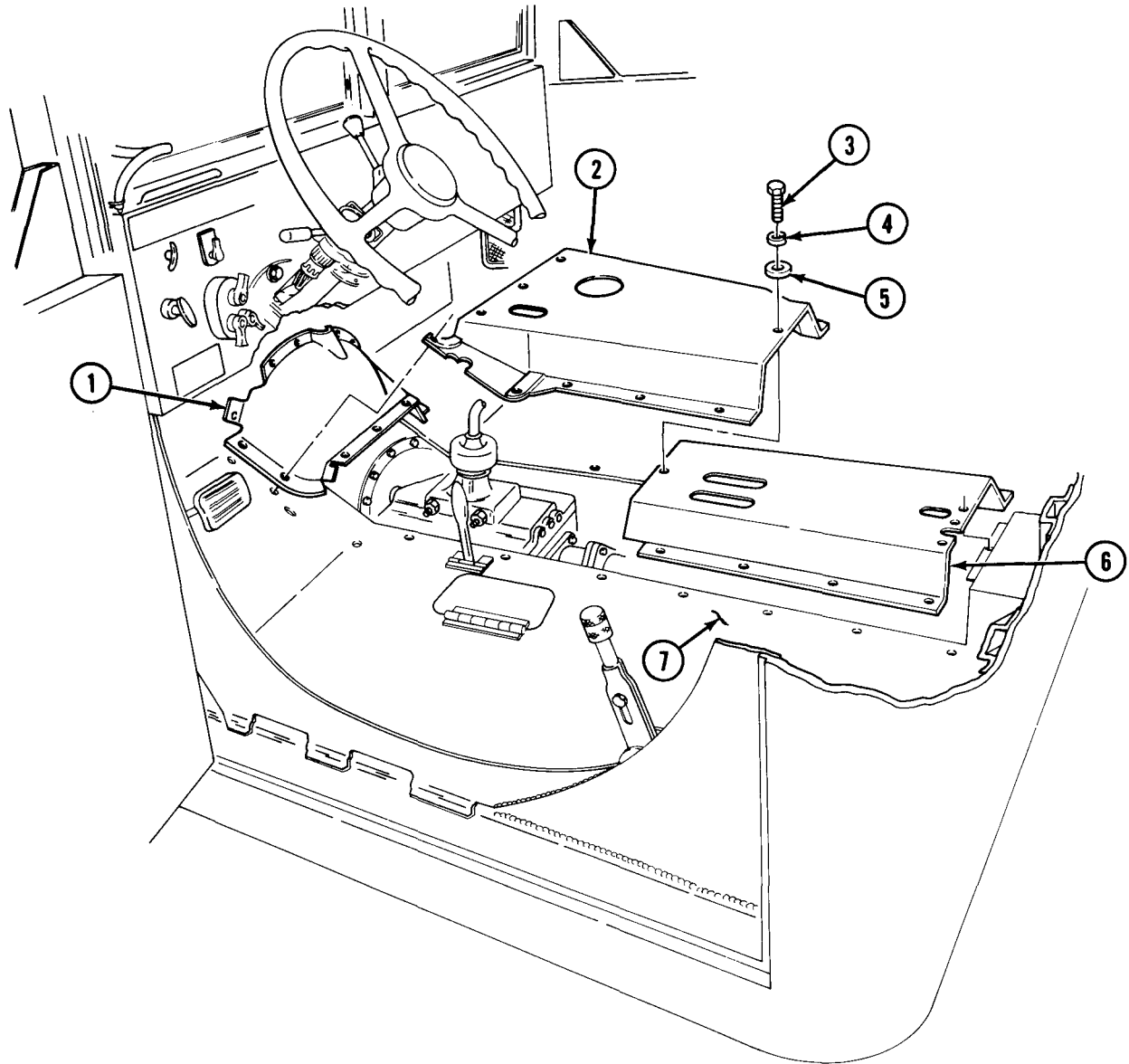

FOLLOW-ON TASK: Install companion seat (para. 11-26).

**11-23. REAR CAB MOUNT REPLACEMENT**

This task covers:

**a. Removal**

**b. Installation**

**INITIAL SETUP:**

APPLICABLE MODELS

All

MATERIALS/PARTS

Two locknuts

PERSONNEL REQUIRED

Two

REFERENCES (TM)

TM 9-2320-361-10

TM 9-2320-361-20P

EQUIPMENT CONDITION

- Parking brake set (TM 9-2320-361-10).
- Spare tire removed (M342A2 only) (TM 9-2320-361-10).

GENERAL SAFETY INSTRUCTIONS

- Support cab while replacing mount.
- Do not place fingers between frame and crossmember.

**WARNING**

Do not place fingers between frame and crossmember while replacing mount. Doing so may result in injury to personnel.

**NOTE**

Assistant will help with entire procedure.

1. Remove two rear cab mount locknuts (9), washers (8), screws (2), springs (4), and four washers (3) from bracket (5) and frame (7). Discard locknuts (9).

**WARNING**

Support cab body while in raised position for mount replacement. Failure to do so may result in injury to personnel.

**CAUTION**

Do not raise rear of cab too high when removing mounts. Damage to cab may result.

2. Raise cab (1) to provide clearance and remove two mounts (6) from frame (7).

**b. Installation**

1. Install two new mounts (6) on frame (7).
2. Lower cab (1) on mounts (6).
3. Install two springs (4) and four washers (3) on two screws (2) and install screws (2) through bracket (5), mounts (6), and frame (7).
4. Install two washers (8) and two new locknuts (9) on screws (2). Tighten locknuts (9) to compress springs (4) to height of 1.78 in. (4.52 cm).

11-23. REAR CAB MOUNT REPLACEMENT (Contd)

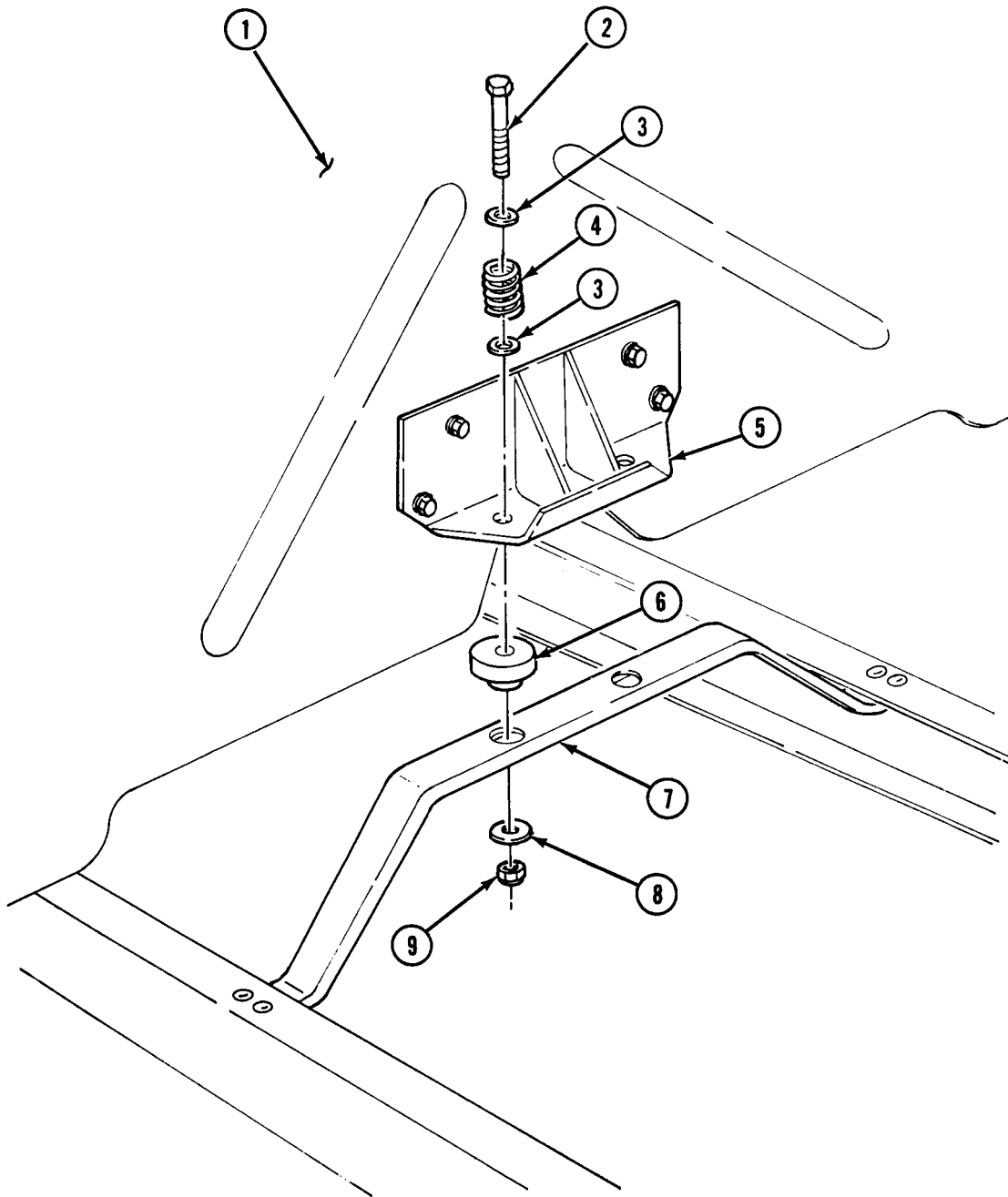

FOLLOW-ON TASK: Install spare tire (M342A2 only) (TM 9-2320-361-10).



**11-24. WATER CAN BRACKET AND RUNNING BOARD REPLACEMENT**

This task covers:

- a. Water Can Bracket Removal
- b. Running Board Removal

- c. Running Board Installation
- d. Water Can Bracket Installation

INITIAL SETUP:

APPLICABLE MODELS

All

MATERIALS/PARTS

Ten locknuts

REFERENCES (TM)

TM 9-2320-361-10

TM 9-2320-361-20P

EQUIPMENT CONDITION

Parking brake set (TM 9-2320-361-10).

**a. Water Can Bracket Removal**

1. Remove strap (9) from water can bracket (2).
2. Remove six screws (1), locknuts (3), and water bracket (2) from toolbox (4) and running board (8). Discard locknuts (3).

**b. Running Board Removal**

Remove four screws (6), locknuts (7), and running board (8) from two supports (5). Discard locknuts (7).

**c. Running Board Installation**

Install running board (8) on two supports (5) with four screws (6) and new locknuts (7).

**d. Water Can Bracket Installation**

1. Install water can bracket (2) on running board (8) and toolbox (4) with six screws (1) and new locknuts (3).
2. Install strap (9) on water can bracket (2).

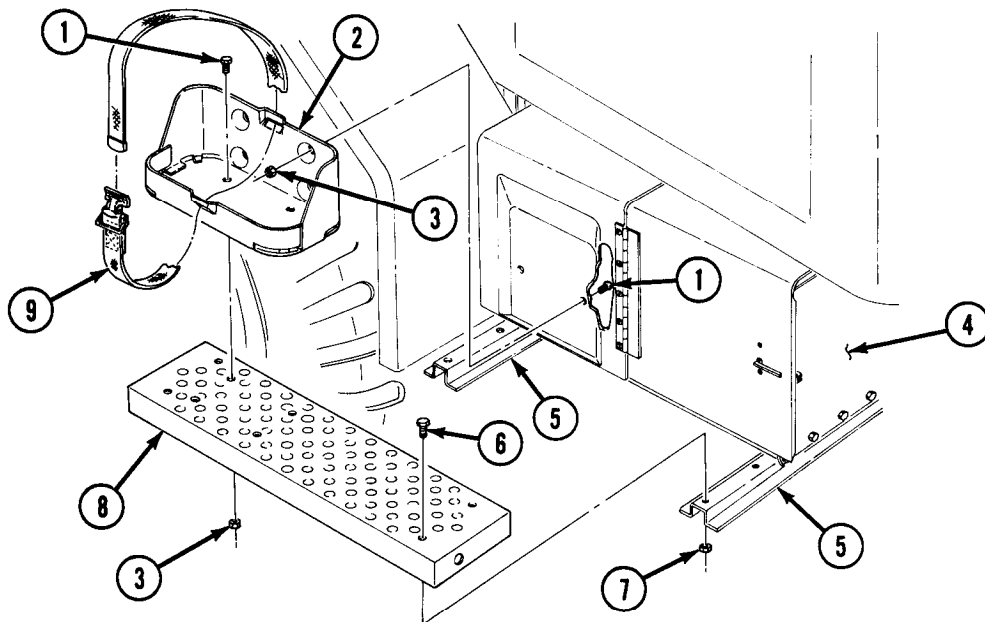

## 11-25. CAB SOFT TOP TURNBUTTONS AND LASHING HOOKS REPLACEMENT

This task covers:

- a. Turnbuttons and Snap Shank Removal
- b. Lashing Hooks Removal

- c. Lashing Hooks Installation
- d. Turnbuttons and Snap Shank Installation

INITIAL SETUP:

APPLICABLE MODELS

All

MATERIALS/PARTS

Twelve locknuts

REFERENCES (TM)

TM 9-2320-361-10

TM 9-2320-361-20P

EQUIPMENT CONDITION

Parking brake set (TM 9-2320-361-10).

### a. Turnbuttons and Snap Shank Removal

1. Remove twelve turnbuttons (2) from cab (3).
2. Remove two snap shanks (1) from windshield frame (8).

### b. Lashing Hooks Removal

1. Remove rope (7) from lashing hooks (4).
2. Remove twelve locknuts (6), screws (5), and six lashing hooks (4) from cab (3). Discard locknuts (6).

### c. Lashing Hooks Installation

1. Install six lashing hooks (4) on cab (3) with twelve screws (5) and new locknuts (6).
2. Install rope (7) on lashing hooks (4).

### d. Turnbuttons and Snap Shank Installation

1. Install two snap shanks (1) on windshield frame (8).
2. Install twelve turnbuttons (2) on cab (3).

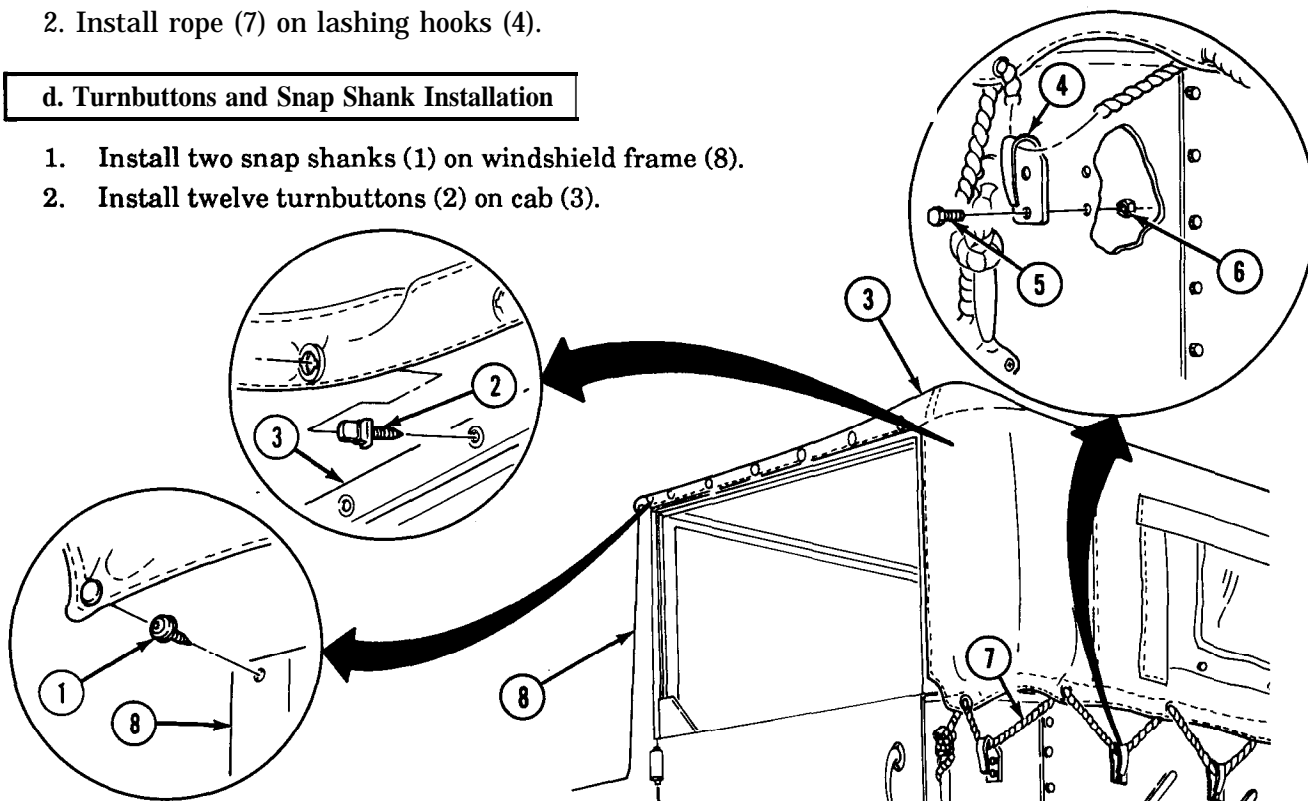

**11-26. COMPANION SEAT MAINTENANCE**

This task covers:

- |  |  |
|--|--|
| <ul style="list-style-type: none"> <li>a. Companion Seat Backrest Removal</li> <li>b. Companion Seat Cushion Removal</li> <li>c. Companion Seat Removal</li> <li>d. Frame Disassembly</li> </ul> | <ul style="list-style-type: none"> <li>e. Frame Assembly</li> <li>f. Companion Seat Installation</li> <li>g. Companion Seat Cushion Installation</li> <li>h. Companion Seat Backrest Installation</li> </ul> |
|--|--|

**INITIAL SETUP**

APPLICABLE MODELS

All

MATERIAL/PARTS

Six locknut  
 Seven cotter pins  
 Four screw-assembled washers

REFERENCES (TM)

TM 9-2320-361-10  
 TM 9-2320-361-20P

EQUIPMENT CONDITION

Parking brake set (TM 9-2320-361-10).

**a. Companion Seat Backrest Removal**

Remove backrest (1) from backrest frame (29).

**b. Companion Seat Cushion Removal**

1. Remove screw (4) and locknut (17) from link (15) and cushion (18). Discard locknut (17).
2. Remove cotter pin (25), washers (27), pin (28), and cushion (18) from cushion frame (21). Discard cotter pin (28).

**c. Companion Seat Removal**

1. Unlatch fastener (7) from backrest frame (29).

**NOTE**

If fastener is damaged, refer to para. 11-13.

2. Remove four screw-assembled washers (20) and cushion frame (21) from cab floor (13). Discard screw-assembled washers (20).

**d. Frame Disassembly**

1. Remove four cotter pins (3), washers (2), pins (6), and backrest frame (29) from link (5), link (26), and cushion frame (21). Discard cotter pins (3).
2. Remove locknut (19), screw (24), two washers (22), sleeve (23), and link (26) from cushion frame (21). Discard locknut (19).
3. Remove cotter pin (12), pin (16), and link (15) from cushion frame (21). Discard cotter pin (12).
4. Remove cotter pin (9), washer (8), and link (5) from cushion frame (21). Discard cotter pin (9).
5. Remove four locknuts (14), screws (10), and leg (11) from cushion frame (21). Discard locknuts (14).

**e. Frame Assembly**

1. Install leg (11) on cushion frame (21) with four screws (10) and new locknuts (14).
2. Install link (5) on cushion frame (21) with washer (8) and new cotter pin (9),
3. Install link (15) on cushion frame (21) with pin (16) and new cotter pin (12).
4. Install link (26) on cushion frame (21) with screw (24), two washers (22), sleeve (23), and new locknut (19).

## 11-26. COMPANION SEAT MAINTENANCE (Contd)

5. Install link (5) and link (26) on backrest frame (29) with four pins (6), washers (2), and new cotter pins (3).

### f. Companion Seat Installation

1. Install backrest (1) on frame (29).
2. Install cushion frame (21) on cab floor (13) with four screw-assembled washers (20).
3. Latch fastener (7) on backrest frame (29).

### g. Companion Seat Cushion Installation

1. Install cushion (18) on cushion frame (21) with pin (28), washer (27), and new cotter pin (25).
2. Install link (15) on cushion (18) with screw (4) and new locknut (17).

### h. Companion Seat Backrest Installation

Install backrest (1) on backrest frame (29).

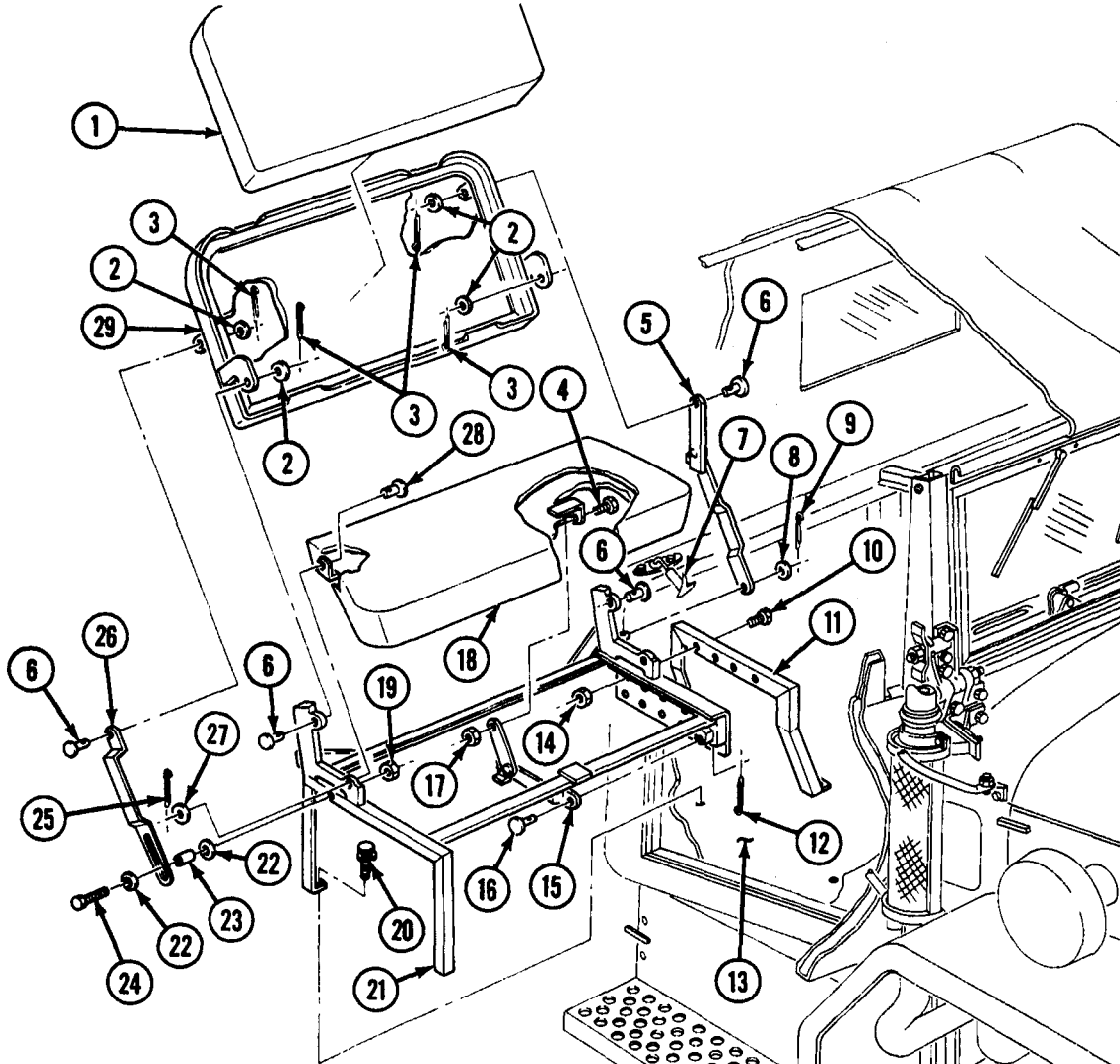

**11-27. DRIVER'S SEAT BASE MAINTENANCE**

This task covers:

- a. Removal
- b. Inspection and Repair

c. Installation

**INITIAL SETUP:**

APPLICABLE MODELS

All

MATERIALS/PARTS

Twelve lockwashers  
Pin  
GAA grease (Appendix C, Item 13)

PERSONNEL REQUIRED

Two

REFERENCES (TM)

TM 9-2320-361-10  
TM 9-2320-361-20P  
TM 9-237

EQUIPMENT CONDITION

- Parking brake set (TM 9-2320-361-10).
- Driver's seat removed (para. 11-28).
- Driver's seat cushion, backrest, frame, and seat adjuster removed (para. 11-29).

**NOTE**

Assistant will help with entire procedure.

1. Turn crank (2) counterclockwise to remove tension on spring (3).
2. Remove two nuts (1), screws (7), and shock absorber (5) from seat base (4) and top frame (6).
3. Remove four nuts (8), lockwashers (9), screws (11), and two brackets (10) from seat base (4). Discard lockwashers (9).
4. Remove spring (3) from seat base (4) and top frame (6).

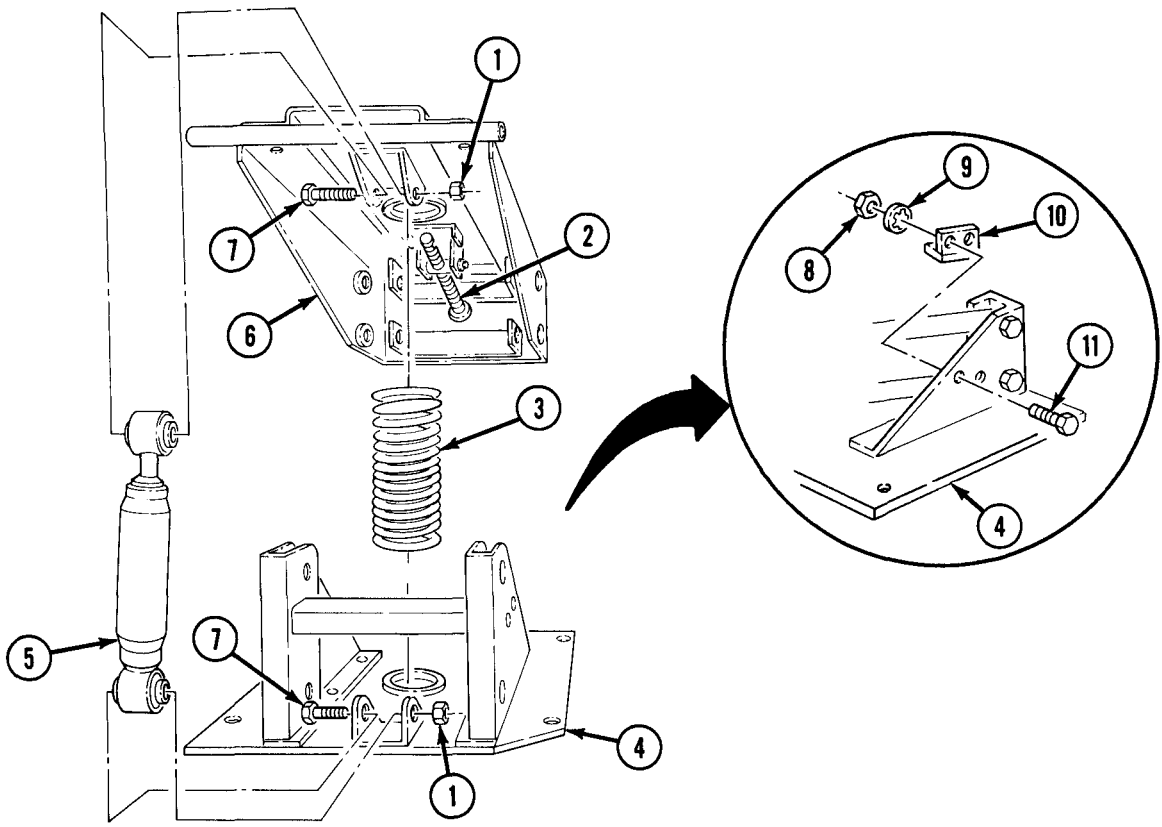

11-27. DRIVER'S SEAT BASE MAINTENANCE (Contd)

5. Tag struts for installation.
6. Remove four nuts (18), lockwashers (13), screws (17), and lower strut (19) from top frame (6) and seat base (4). Discard lockwashers (13).
7. Remove two top nuts (16), lockwashers (15), torque rod (14), spring (26), sleeve (27), and spring (26) from top frame (6) and upper strut (23). Discard lockwashers (15).
8. Remove two nuts (22), lockwashers (21), screws (20), and upper strut (23) from seat base (4). Discard lockwashers (21).
9. Remove pin (24) from crank (2). Discard pin (24).
10. Remove crank (2) and washer (25) from swivel nut (12) and top frame (6).

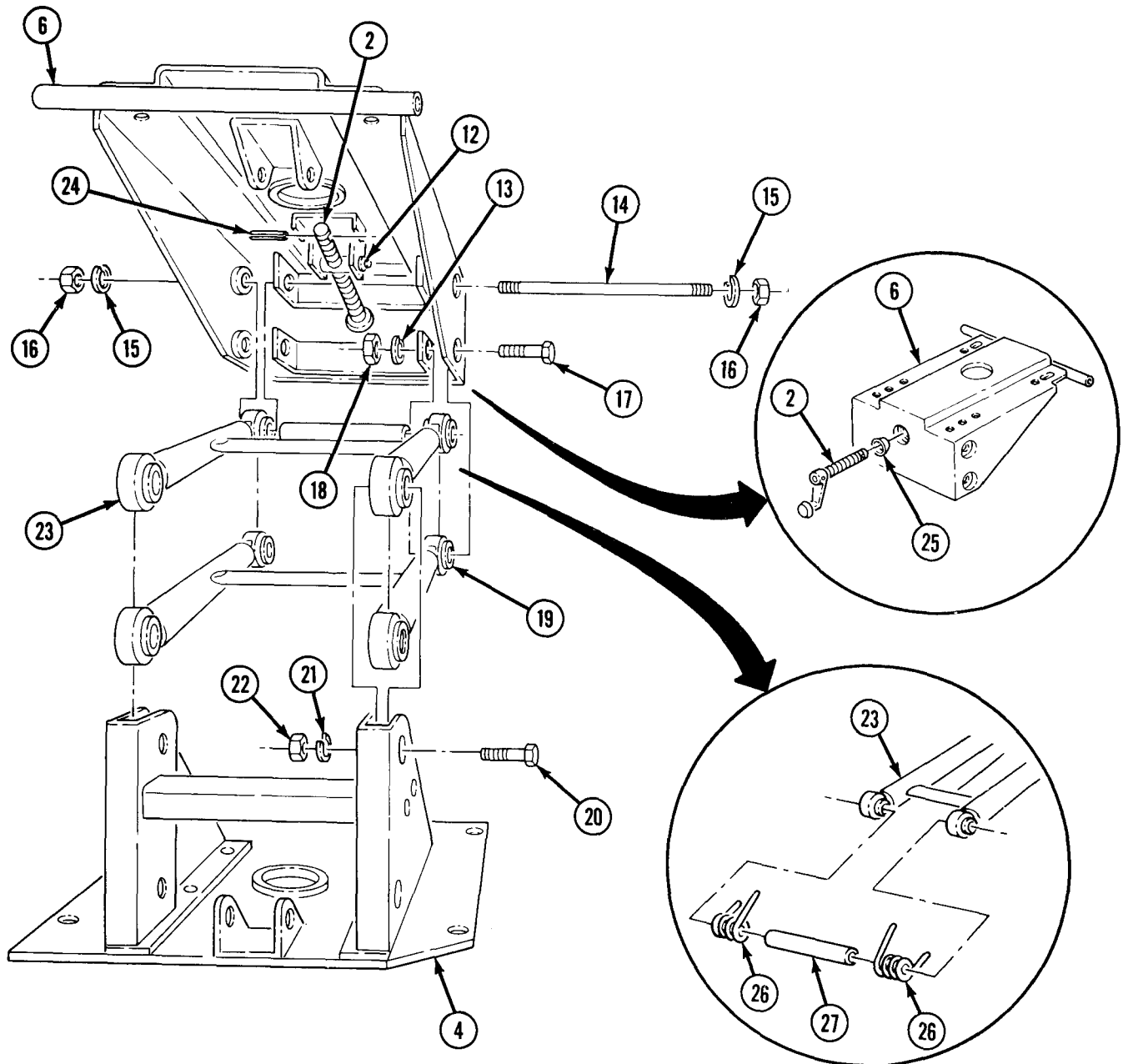

11-27. DRIVER'S SEAT BASE MAINTENANCE (Contd)

b. Inspection and Repair

1. Refer to para. 2-10 for general inspection.
2. Refer to TM 9-237 for welding.
3. Inspect seat base (3), top frame (2), upper strut (6), lower strut (7), and sleeve(9) for cracks, bends, and breaks. Repair if cracked, bent, or broken.
4. Inspect torque rod (5), spring (4), crank (1), and two springs (8) for cracks, bends, and breaks. Replace if cracked, bent, or broken.
5. Inspect shock absorber (10) for cracks, bends, breaks, and leakage. Replace if cracked, bent, broken, or leaking.

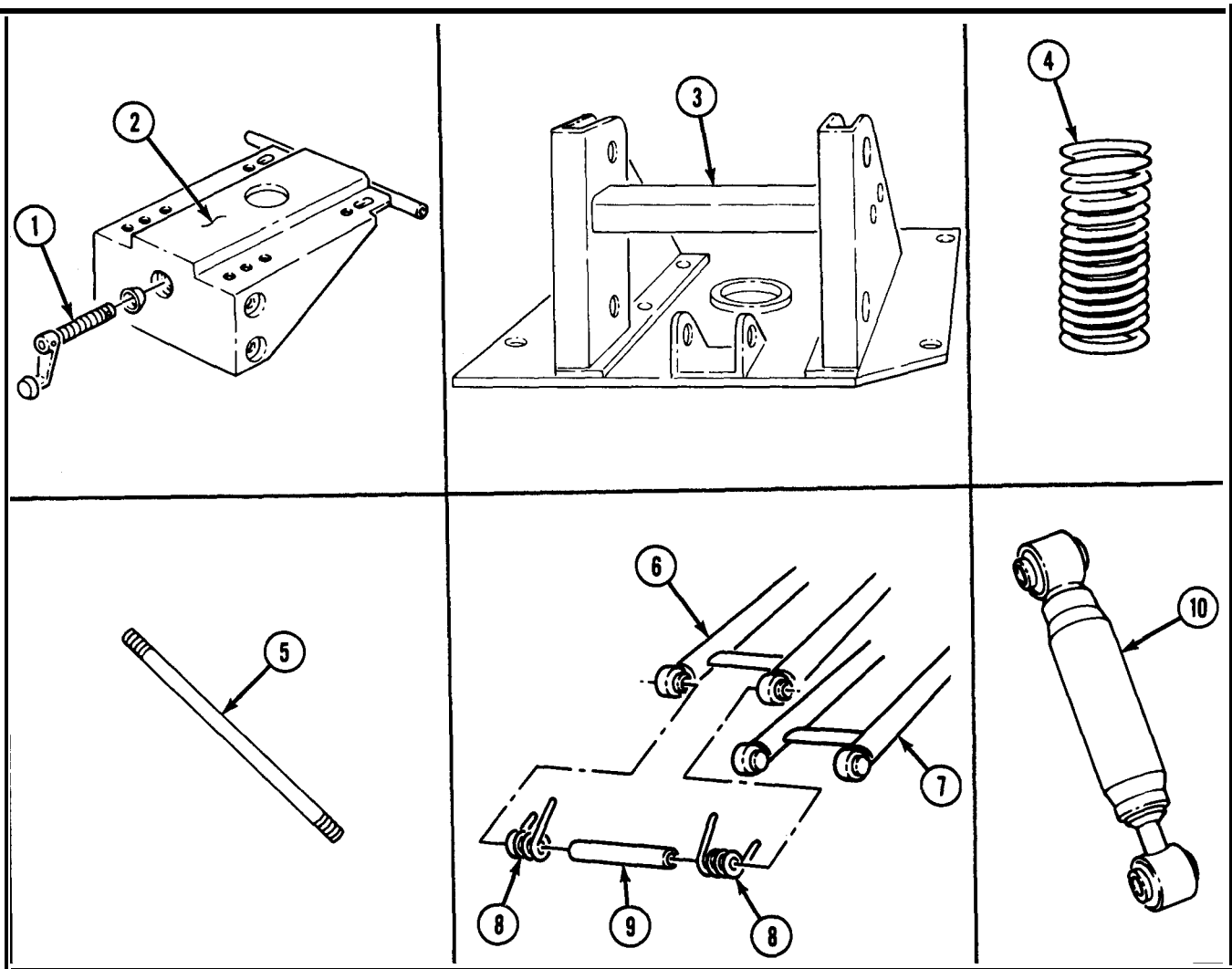

## 11-27. DRIVER'S SEATBASE MAINTENANCE (Contd)

### c. Installation

1. Install crank (1) and washer (21) in top frame (2) and swivel nut (11).
2. Install new pin (20) in crank (1).
3. Apply light coat of GAA grease to crank (1) threads.
4. Apply GAA grease to upper strut (6) bushings, lower strut (7) bushings, and torque rod (5).
5. Install upper strut (6), sleeve (9), and two springs (8) on top frame (2) with torque rod (5), two new lockwashers (13), and nuts (14).
6. Install lower strut (7) on top frame (2) and seat base (3) with four screws (15), new lockwashers (12), and nuts (16).
7. Install upper strut (6) on seat base (3) with two screws (17), new lockwashers (18), and nuts (19).

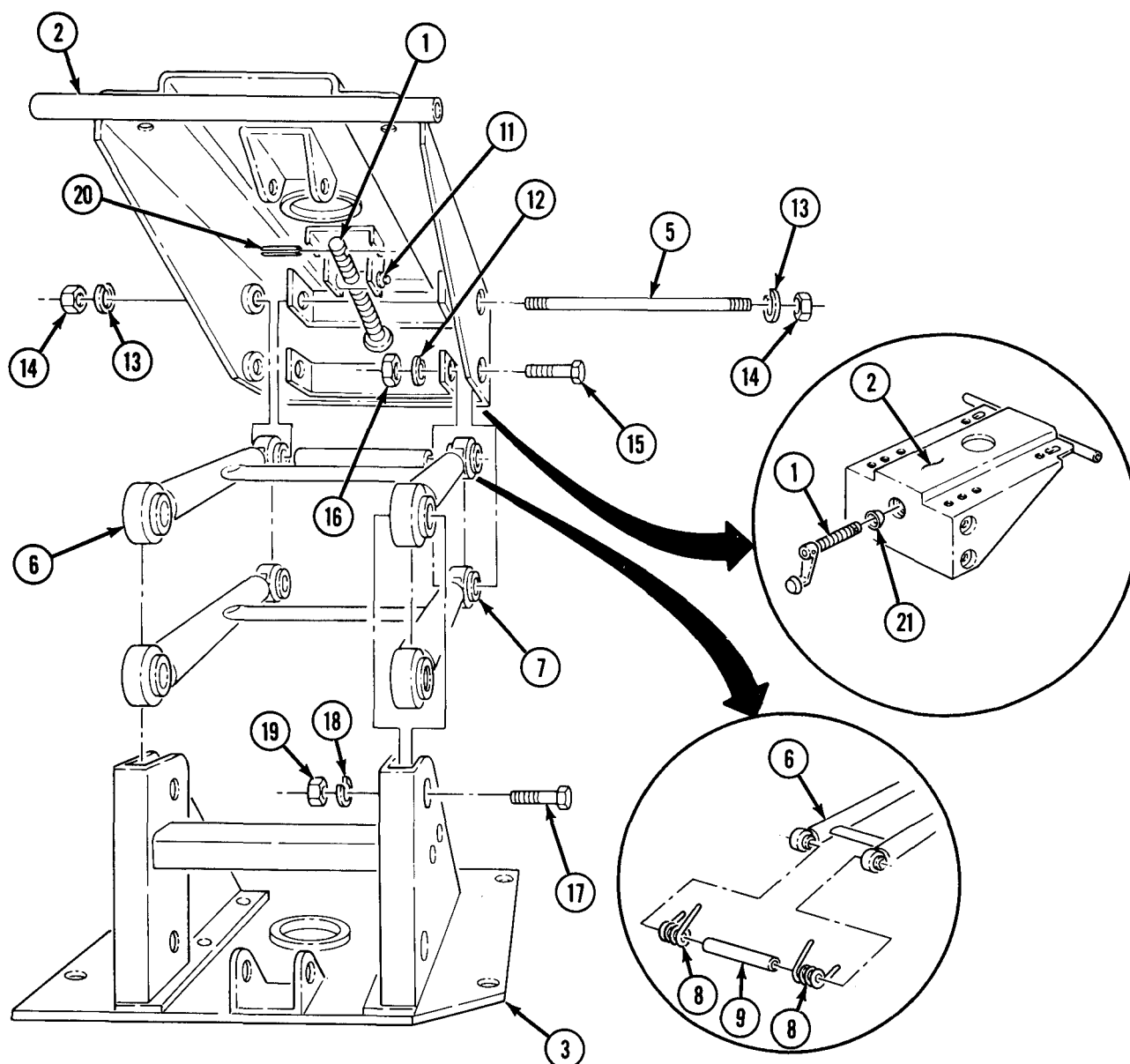



11-27. DRIVER'S SEAT BASE MAINTENANCE (Contd)

8. Install spring (2) in seat base (3) and top frame (6).
9. Install two brackets (9) on seat base (3) with four screws (10), new lockwashers (8), and nuts (7).
10. Install shock absorber (5) on top frame (6) and seat base (3) with two screws (4) and nuts (1).

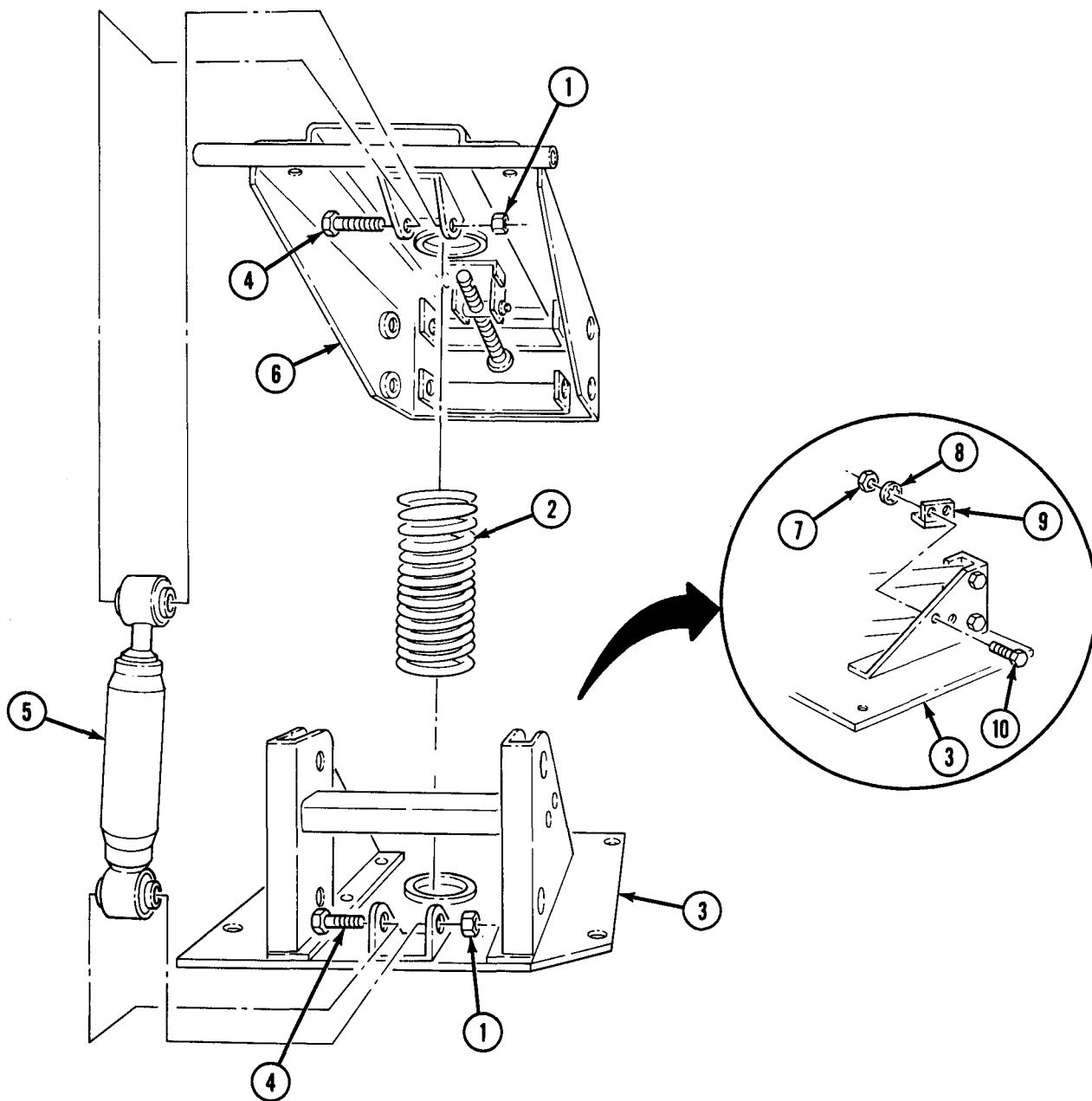

- FOLLOW-ON TASKS:
- Install seat cushion, backrest, frame, and seat adjuster (para. 11-29).
  - Install driver's seat (para. 11-28).

## 11-28. DRIVER'S SEAT REPLACEMENT

This task covers:

### a. Removal

### b. Installation

INITIAL SETUP:

#### APPLICABLE MODELS

All

#### MATERIALS/PARTS

Four screw-assembled lockwashers

#### REFERENCES (TM)

TM 9-2320-361-10

TM 9-2320-361-20P

#### EQUIPMENT CONDITION

Parking brake set (TM 9-2320-361-10).

### a. Removal

Remove four screw-assembled lockwashers (1) and driver's seat and base (2) from cab floor (3). Discard screw-assembled lockwashers (1).

### b. Installation

Install driver's seat and base (2) on cab floor (3) with four new screw-assembled lockwashers (1).

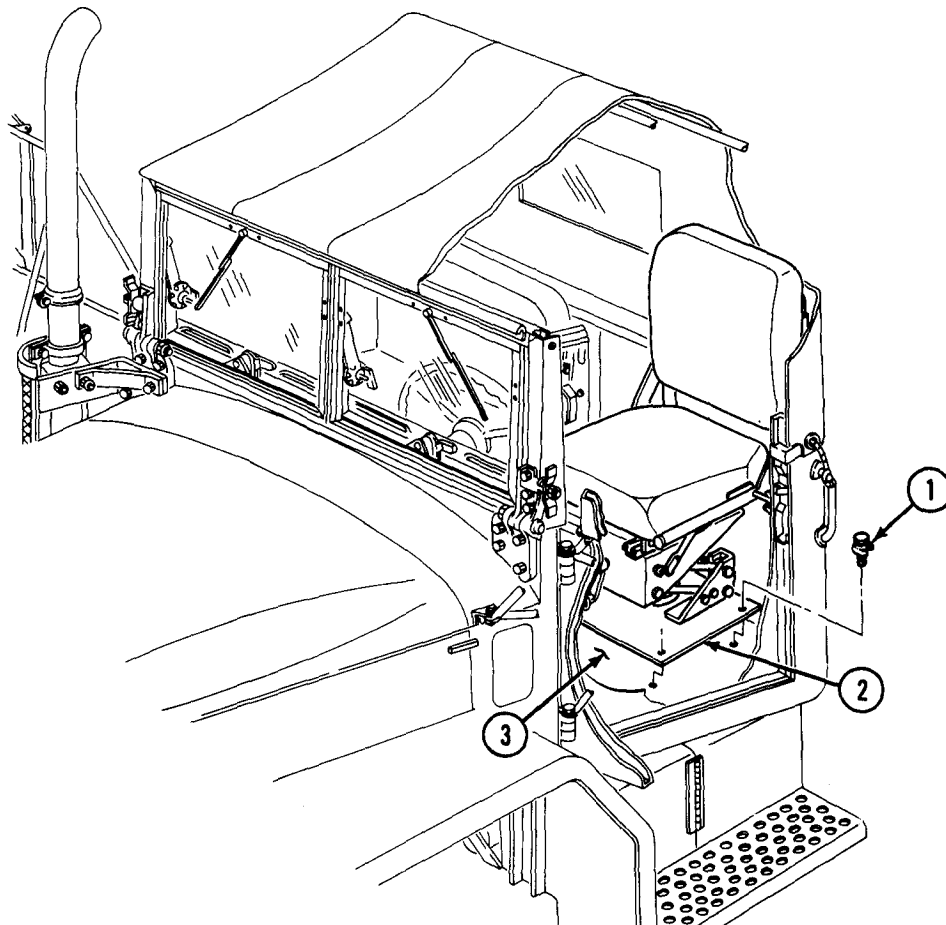

**11-29. DRIVER'S SEAT CUSHION, BACKREST, FRAME, AND SEAT ADJUSTER REPLACEMENT**

This task covers:

- |  |  |
|--|--|
| <ul style="list-style-type: none"> <li>a. Driver's Seat Cushion Removal</li> <li>b. Driver's Seat Backrest Removal</li> <li>c. Driver's Seat Frame Removal</li> <li>d. Driver's Seat Adjuster Removal</li> </ul> | <ul style="list-style-type: none"> <li>e. Driver's Seat Adjuster Installation</li> <li>f. Driver's Seat Frame Installation</li> <li>g. Driver's Seat Backrest Installation</li> <li>h. Driver's Seat Cushion Installation</li> </ul> |
|--|--|

**INITIAL SETUP:**

APPLICABLE MODELS  
All

REFERENCES (TM)  
TM 9-2320-361-10  
TM 9-2320-361-20P

MATERIALS/PARTS  
Eight locknuts  
Six lockwashers

EQUIPMENT CONDITION  
Parking brake set (TM 9-2320-361-10).

**a. Driver's Seat Cushion Removal**

Remove four screws (14), lockwashers (15), two seat cushion brackets (16), and washers (13) from seat cushion (17) and seat frame (3). Remove seat cushion (17) from seat frame (3). Discard lockwasher (15).

**b. Driver's Seat Backrest Removal**

1. Remove two screws (6), lockwashers (5), and clips (4) from seat backrest (1) and seat frame (3). Discard lockwashers (5).
2. Remove four screws (7), backrest (1), and plate (2) from seat frame (3).

**c. Driver's Seat Frame Removal**

Remove four locknuts (8) and seat frame (3) from seat adjusters (11). Discard locknuts (8).

**d. Driver's Seat Adjuster Removal**

Remove four locknuts (10), two seat adjusters (11), and release wire (12) from seat base (9). Discard locknuts (10).

**e. Driver's Seat Adjuster Installation**

Install two seat adjusters (11) and wire (12) on seat base (9) with four new locknuts (10).

**f. Driver's Seat Frame Installation**

Install seat frame (3) on seat adjusters (11) with four new locknuts (8).

**g. Driver's Seat Backrest Installation**

1. Install plate (2) and backrest (1) on seat frame (3) with four screws (7).
2. Install two clips (4), two new lockwashers (5), and screws (6) on seat frame (3) and backrest (1).

## 11-29. DRIVER'S SEAT CUSHION, BACKREST, FRAME, AND SEAT ADJUSTER REPLACEMENT (Contd)

### h. Driver's Seat Cushion Installation

1. Position two washers (13), seat cushion brackets (16), and seat cushion (17) on frame (3).
2. Install two seat cushion brackets (16), two washers (13), and seat cushion (17) on seat frame (3) with four screws (14) and new lockwashers (15).

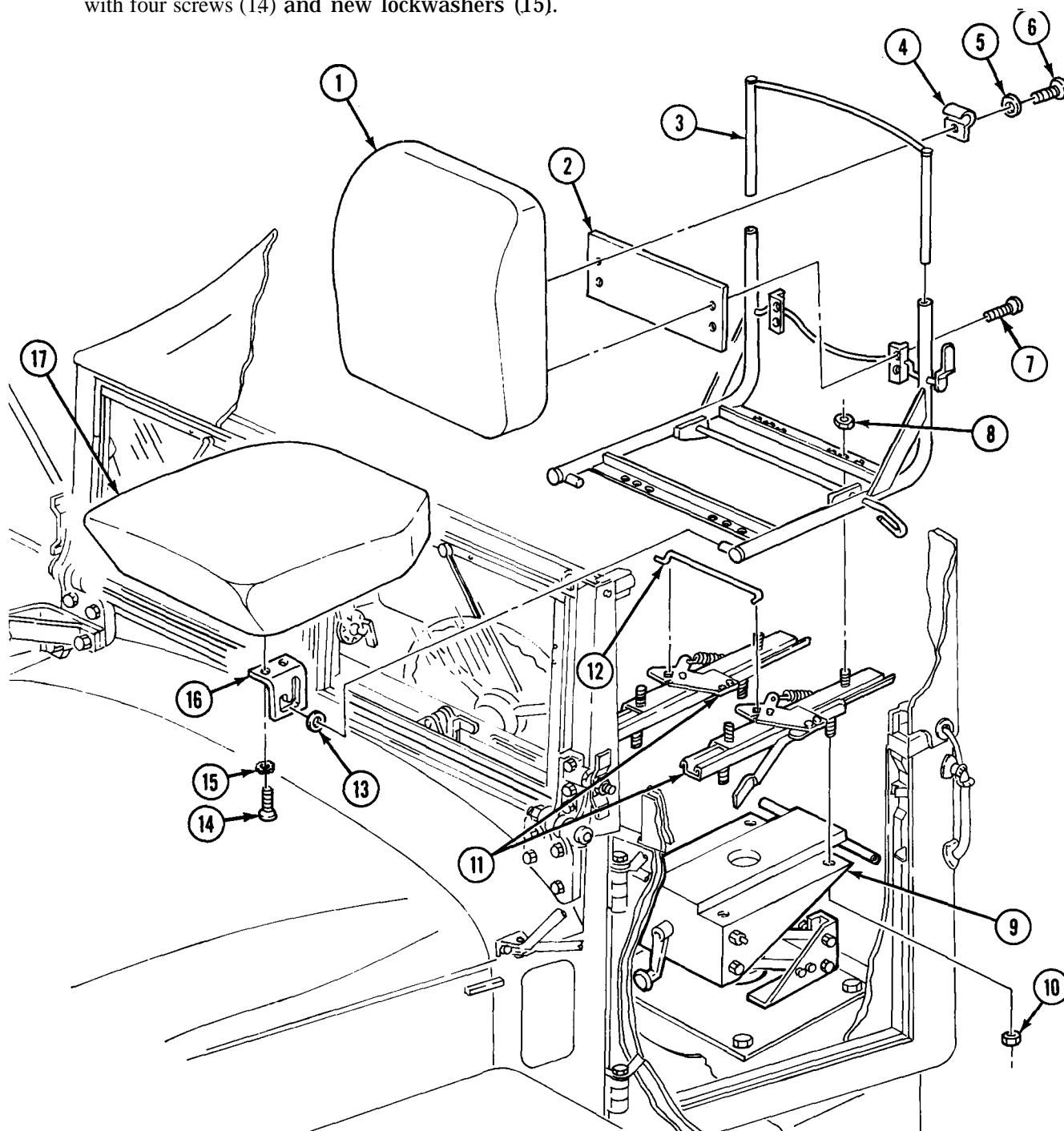

**11-30. FRONT FENDERS MAINTENANCE**

This task covers:

- a. Removal
- b. Inspection and Repair

c. Installation

**INITIAL SETUP:**

APPLICABLE MODELS

All

MATERIALS/PARTS

Four screw-assembled lockwashers  
 Thirteen locknuts  
 Anti-squeak material  
 Adhesive (Appendix C, Item 1)

REFERENCES (TM)

TB 43-0213  
 TC 9-510  
 TM 9-237  
 TM 9-2320-361-10  
 TM 9-2320-361-20P

EQUIPMENT CONDITION

- Parking brake set (TM 9-2320-361-10).
- Hood raised and secured (TM 9-2320-361-10).
- Front wheels removed (TM 9-2320-361-10).
- Side panel removed (para. 11-11).
- Front composite lamp housing and brackets removed (para. 4-41).
- Personnel hot water heater removed (left side only) (para. 11-42).
- Exhaust system removed (right side only) (para. 3-37 or 3-38).
- Airhorn removed (right side only) (para. 4-31).
- Turn signal flasher removed (left side only) (para. 4-20).

**NOTE**

Right and left fenders are replaced the same. This procedure covers right side.

**a. Removal**

1. Remove two screws (30), locknuts (28), clamps (29), and wiring harness (25) from fender support (21). Discard locknuts (28).
2. Remove three screw-assembled lockwashers (16) from fender (13) and cowl (4). Discard screw-assembled lockwashers (16).
3. Remove three locknuts (22), screws (26), fender mount springs (27), and nine washers (23) from fender (13) and fender support (21). Discard locknuts (22).
4. Remove two locknuts (12), screws (7), and washers (6) from light support bracket (10) and fender (13). Discard locknuts (12).
5. Remove three locknuts (11), washers (9), screws (8), and washers (9) from fender (13) and light support bracket (10). Discard locknuts (11).
6. Remove screw-assembled lockwasher (19), locknut (14), screw (17), and brace (18) from flame (5). Discard screw-assembled lockwasher (19) and locknut (14).

**NOTE**

Assistant will help with step 1.

7. Remove two locknuts (3), screws (15), washers (2), fender (13), and fender mount spacer (24) from fender support (21), bracket (20), cowl (4), and light support bracket (10). Discard locknuts (3).
8. Remove anti-squeak material (1) from cowl (4). Discard anti-squeak material (1).

11-30. FRONT FENDERS MAINTENANCE (Contd)

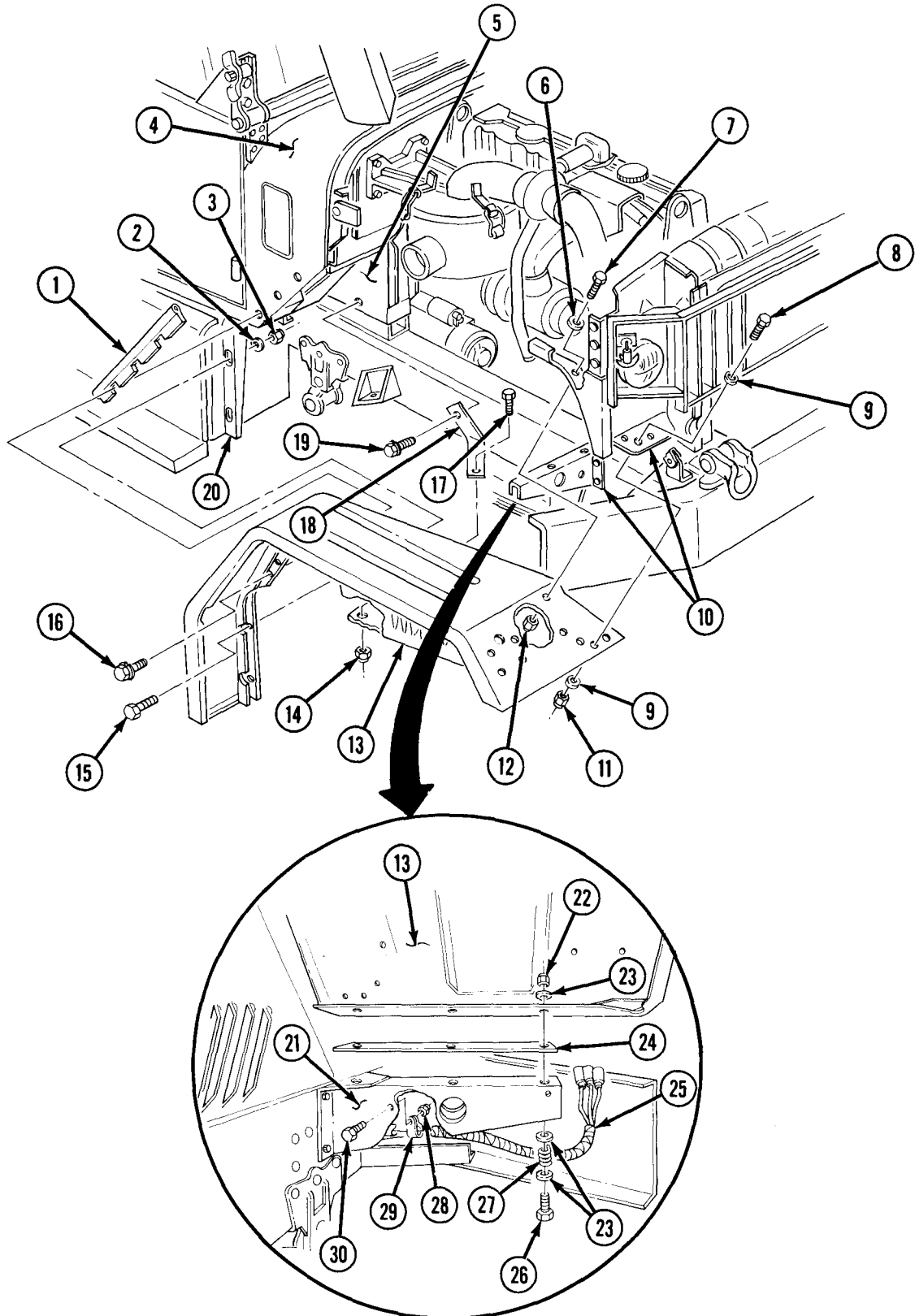

## 11-30. FRONT FENDERS MAINTENANCE (Contd)

### b. Inspection and Repair

1. Inspect fender for rust, dents, bends, and cracks.
2. Refer to para. 2-5 for general inspection procedure.
3. Refer to TM 9-237 for welding instructions.
4. Refer to TC 9-510 for metal body repair.
5. Refer to TB 43-0213 for rustproofing instructions.

### c. Installation

#### NOTE

Assistant will help with step 1.

1. Install fender mount spacer (24), new anti-squeak material (1), and fender (13) on cowl (4) and fender support (21) with three new screw-assembled lockwashers (16), springs (27), nine washers (23), screws (26), and new locknuts (22). Do not tighten locknuts (22) or screw-assembled lockwashers (16).
2. Install brace (18) on frame (5) and fender (13) with new screw-assembled lockwasher (19), screw (17), and new locknut (14). Do not tighten screw-assembled lockwasher (19) or locknut (14).
3. Install two screws (15), washers (2), and new locknuts (3) on brace (20) and fender (13). Do not tighten locknuts (3).
4. Install fender (13) to light support bracket (10) with two screws (7), washers (6), and new locknuts (12). Do not tighten locknuts (12).
5. Install fender (13) to light support bracket (10) with three washers (9), screws (8), washers (9), and new locknuts (11). Do not tighten locknuts (11).

#### NOTE

Assistant will help with step 6.

6. Aline fender (13) with cowl (4), brace (20), support (21), and light support bracket (10). Tighten screw-assembled lockwashers (16) and (19) and locknuts (22), (3), (11), (12), and (14).
7. Install wiring harness (25) on fender support (21) with two clamps (29), screws (30), and new locknuts (28).

11-30. FRONT FENDERS MAINTENANCE (Contd)

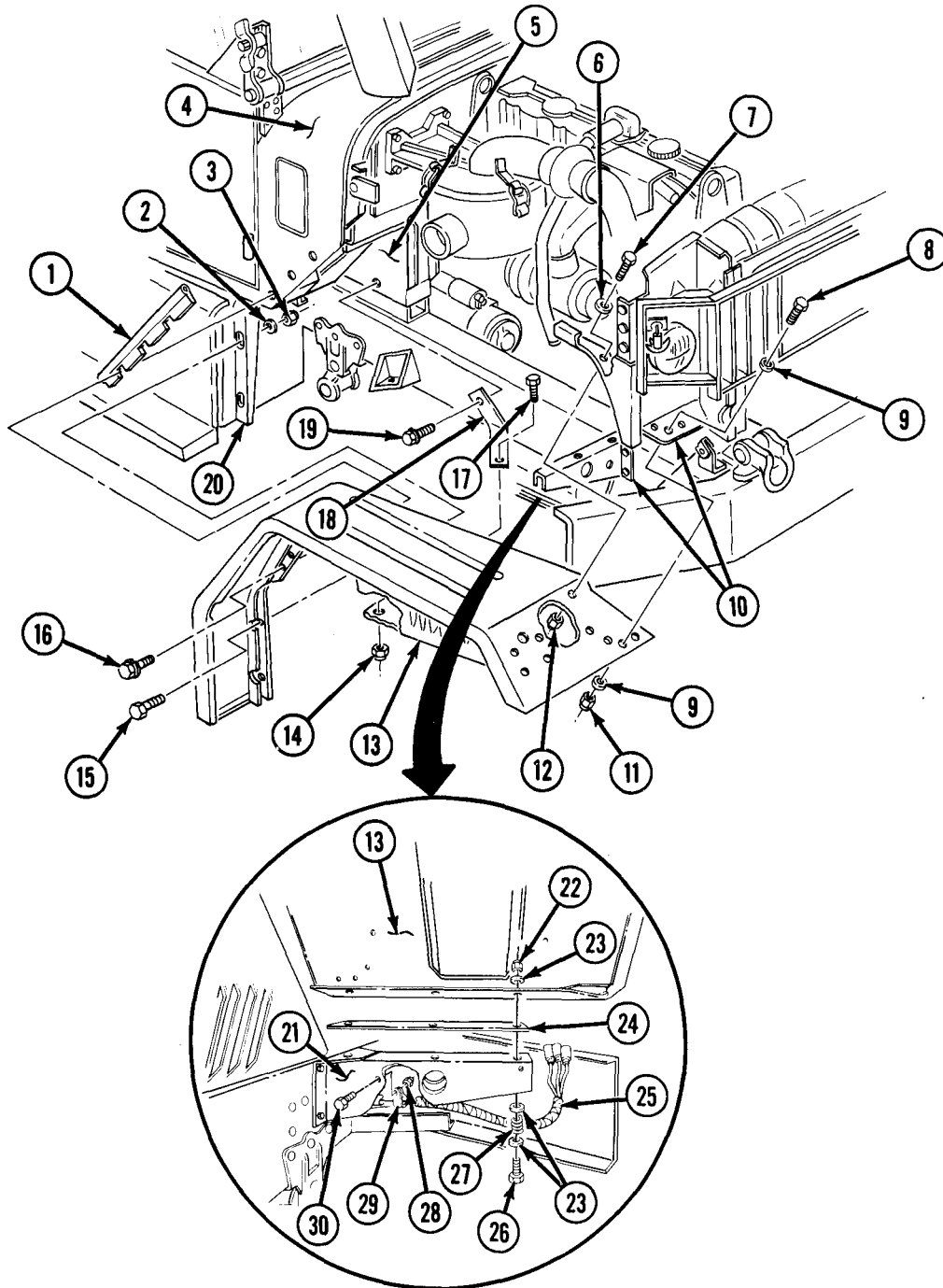

FOLLOW-ON TASKS:

- Install turn signal flasher (left side only) (para. 4-20).
- Install personnel hot water heater (left side only) (para. 11-42).
- Install exhaust system (right side only) (para. 3-37 or 3-38).
- Install airhom (right side only) (para. 3-31).
- Install front composite light housing and brackets (para. 4-41).
- Install side panel (para. 11-11).
- Install front wheels (TM 9-2320-361-10).



Section II. ACCESSORIES MAINTENANCE

**11-31. ACCESSORIES MAINTENANCE INDEX**

PARA. NO.	TITLE	PAGE NO.
11-32.	Pioneer Tool Bracket Kit Replacement	11-57
11-33.	Windshield Wiper Motor Air Tubes Replacement	11-67
11-34.	Windshield Wiper Blade, Arm, and Motor Replacement	11-68
11-35.	Windshield Washer Reservoir, Tubing, Jet, and Pump Replacement	11-70
11-36.	Mirror and Brackets Replacement	11-72
11-37.	Data Plate Replacement	11-74
11-38.	Personnel Heater Supply Hose Replacement	11-75
11-39.	Personnel Heater Diverter Replacement	11-76
11-40.	Personnel Heater Air Vent Replacement	11-77
11-41.	Personnel Heater Control Cables Replacement	11-78
11-42.	Personnel Hot Water Heater Replacement	11-80
11-43.	Personnel Heater Defroster Hoses Replacement	11-85
11-44.	Reflector Replacement	11-86

## 11-32. PIONEER TOOL BRACKET KIT REPLACEMENT

This task covers:

### a. Removal

### b. Installation

INITIAL SETUP:

#### APPLICABLE MODELS

All (except M756A2, M764)

#### REFERENCES (TM)

TM 9-2320-361-10

#### MATERIALS/PARTS

Eight locknuts (M35A2, M35A2C)

Fourteen locknuts (M36A2)

Six locknuts (M49A2C, M56A3)

Eight locknuts (M109A3, M185A3, M50A2)

Four locknuts (M275A2, M342A2)

#### EQUIPMENT CONDITION

Parking brake set (TM 9-2320-361-10).

### a. Removal

#### NOTE

Perform steps 1 through 4 for M35A2 and M35A2C vehicles.

1. Remove two locknuts (6) and screws (10) from support (9) and front splash shield (7). Discard locknuts (6).
2. Remove two locknuts (11), screws (13), and bracket (12) from two supports (1). Discard locknuts (11).
3. Remove two locknuts (5), screws (8), and support (9) from bracket (12). Discard locknuts (5).
4. Remove two locknuts (3), screws (2), and supports (1) from cargo bed sill (4). Discard locknuts (3).

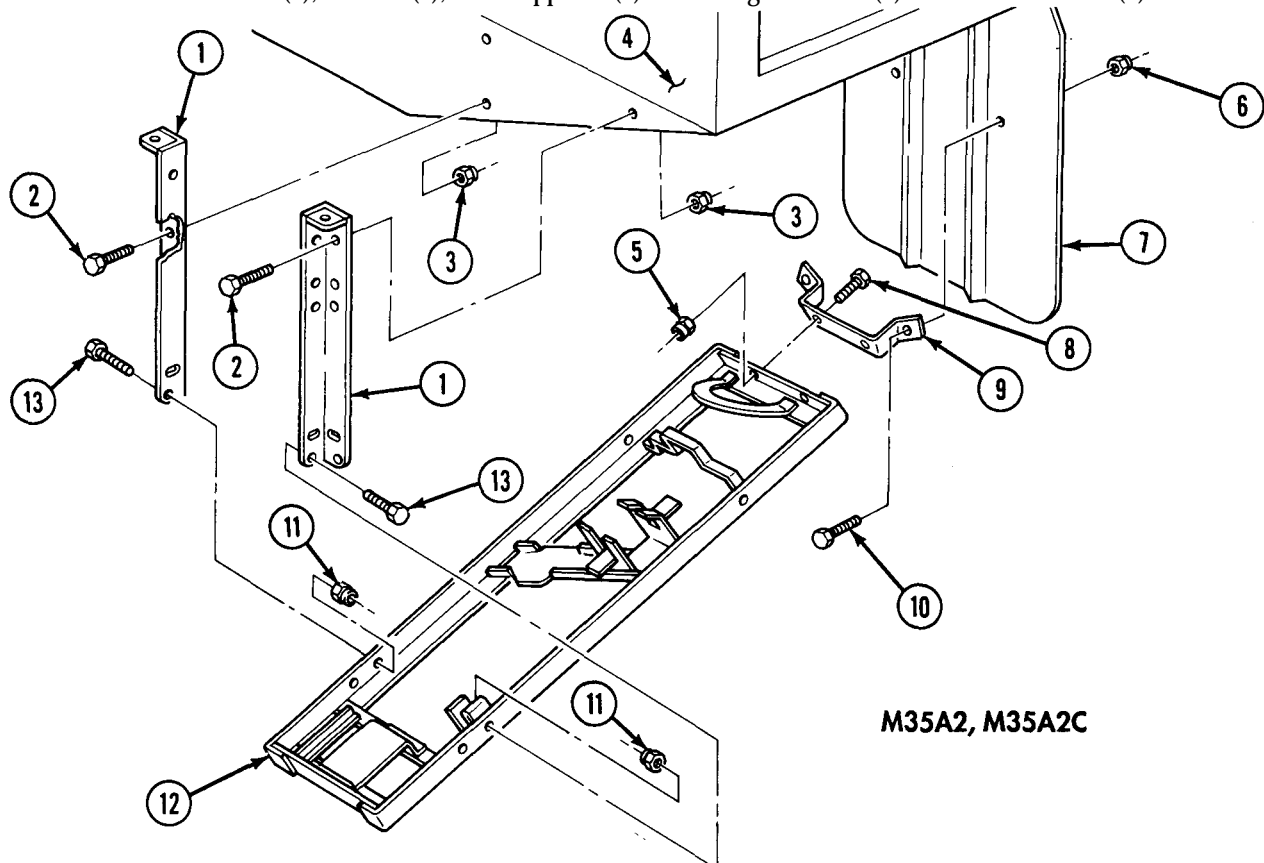

11-32. PIONEER TOOL BRACKETKIT REPLACEMENT (Contd)

**NOTE**

Perform steps 5 through 10 for M36A2 vehicles.

5. Remove two locknuts (8) and screws (11) from support (10) and front splash shield (9). Discard locknuts (8).
6. Remove two locknuts (13), screws (14), and bracket (12) from supports (15). Discard locknuts (13).
7. Remove two locknuts (5), screws (6), and support (10) from bracket (12). Discard locknuts (5).
8. Remove two locknuts (7) and screws (1) from supports (2) and cargo bed crossmember (3). Discard locknuts (7).
9. Remove two locknuts (16) and screws (4) from supports (2) and (15). Discard locknuts (16).
10. Remove four locknuts (17), screws (18), and two supports (15) from supports (2). Discard locknuts (17).

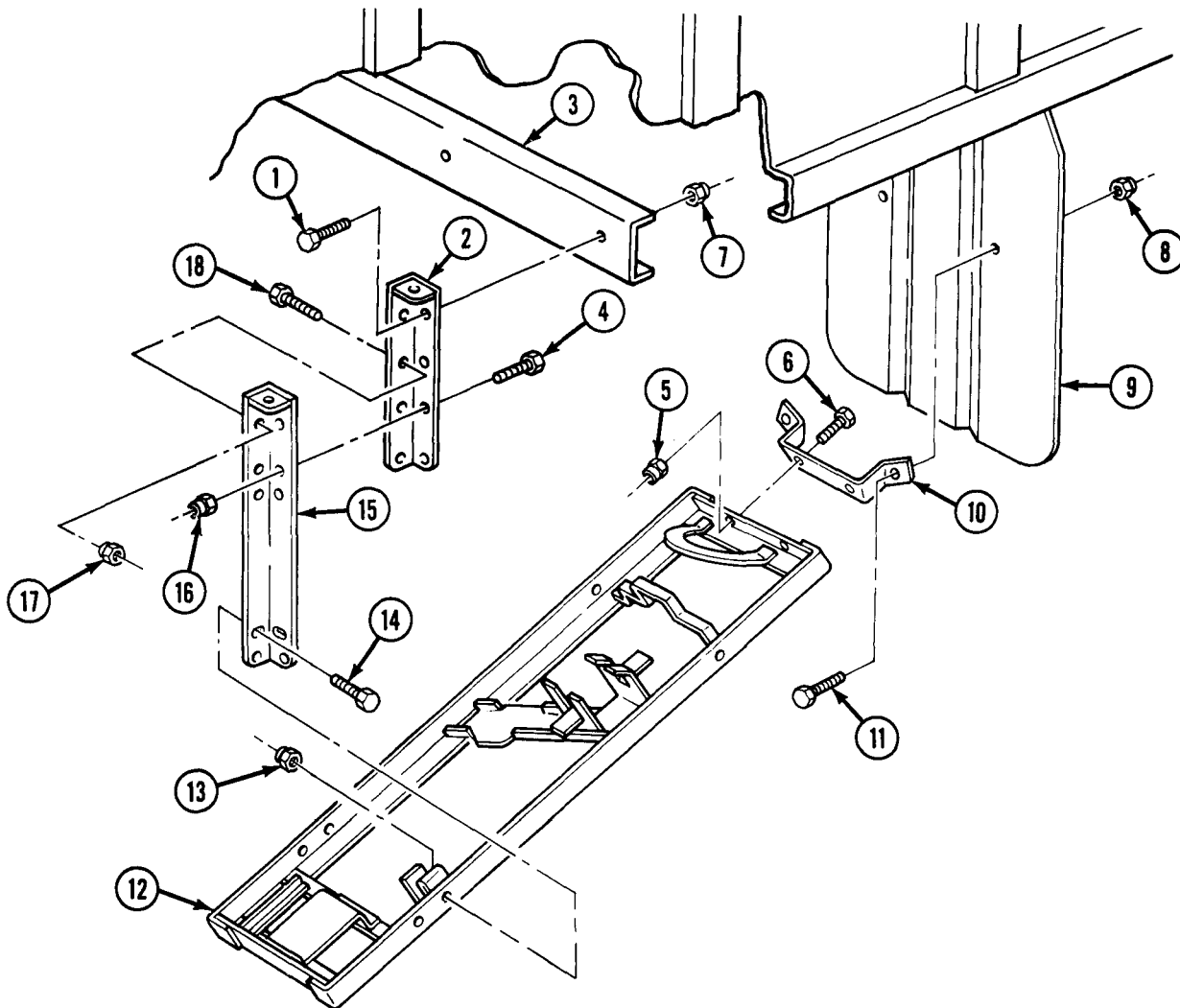

## 11-32. PIONEER TOOL BRACKET KIT REPLACEMENT (Contd)

### NOTE

Perform steps 11 through 13 for M49A2C and M56A3 vehicles.

11. Remove two locknuts (24) and screws (22) from bracket (26) and front splash shield support (23). Discard locknuts (24).
12. Remove two locknuts (25), screws (27), and bracket (26) from supports (19). Discard locknuts (25).
13. Remove two locknuts (28), screws (21), and supports (19) from tank body sill (20). Discard locknuts (28).

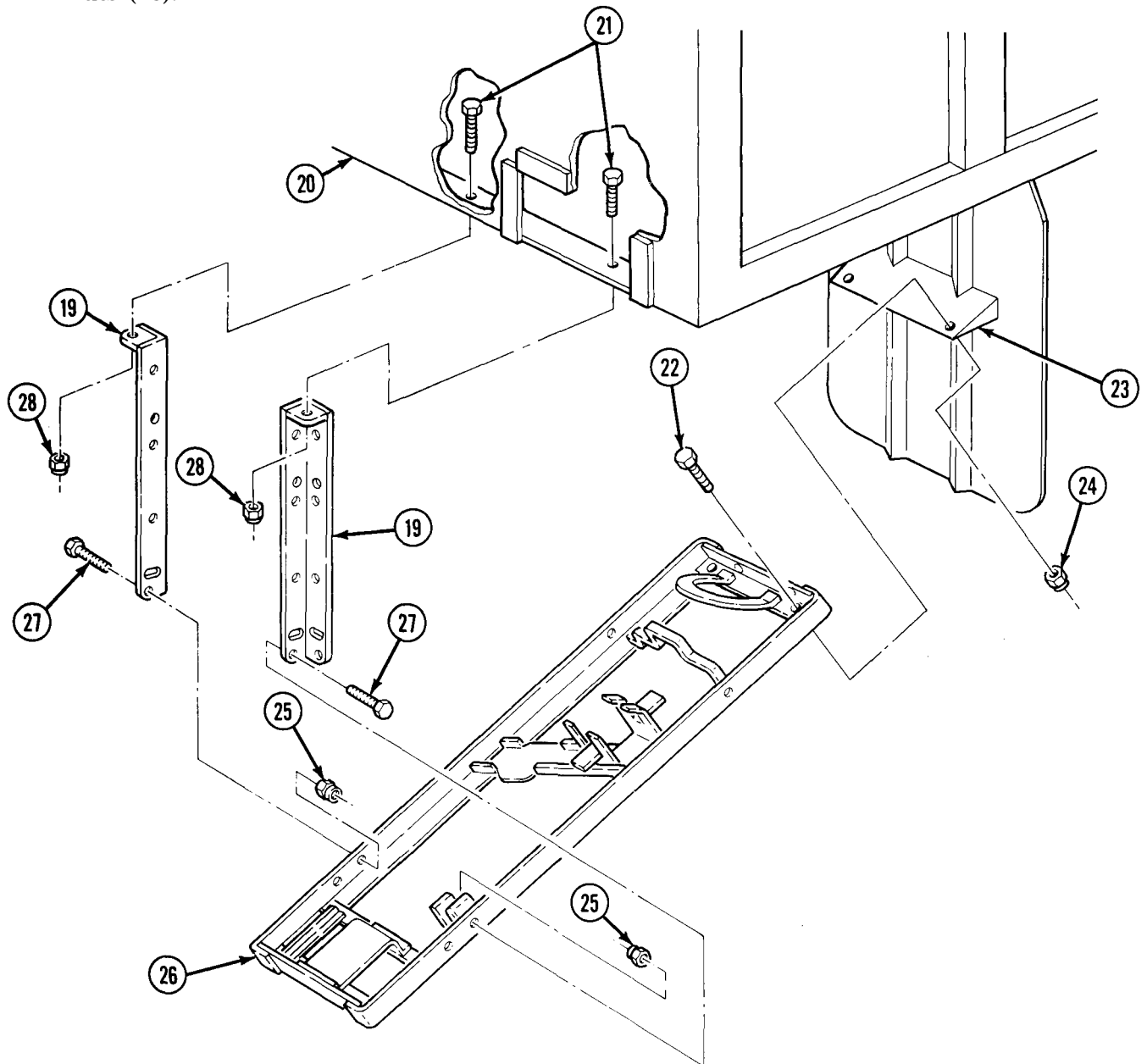

M49A2C, M56A3

**11-32. PIONEER TOOL BRACKET KIT REPLACEMENT (Contd)**

**NOTE**

Perform steps 14 through 17 for M109A3 and M185A3 vehicles.

- 14. Remove two locknuts (6) and screws (9) from supports (8) and front splash shield (7). Discard locknuts (6).
- 15. Remove two locknuts (10), screws (12), and bracket (11) from supports (1). Discard locknuts (10).
- 16. Remove two locknuts (4), screws (5), and supports (8) from bracket (11). Discard locknuts (4).
- 17. Remove two locknuts (3), screws (13), and supports (1) from van body sill (2). Discard locknuts (3).

**NOTE**

Perform steps 18 and 19 for M50A2 vehicles.

- 18. Remove four locknuts (18), screws (15), and bracket (11) with two supports (16) from cross-member (19). Discard locknuts (18).
- 19. Remove four locknuts (14), screws (17), and two supports (16) from bracket (11). Discard locknuts (14).

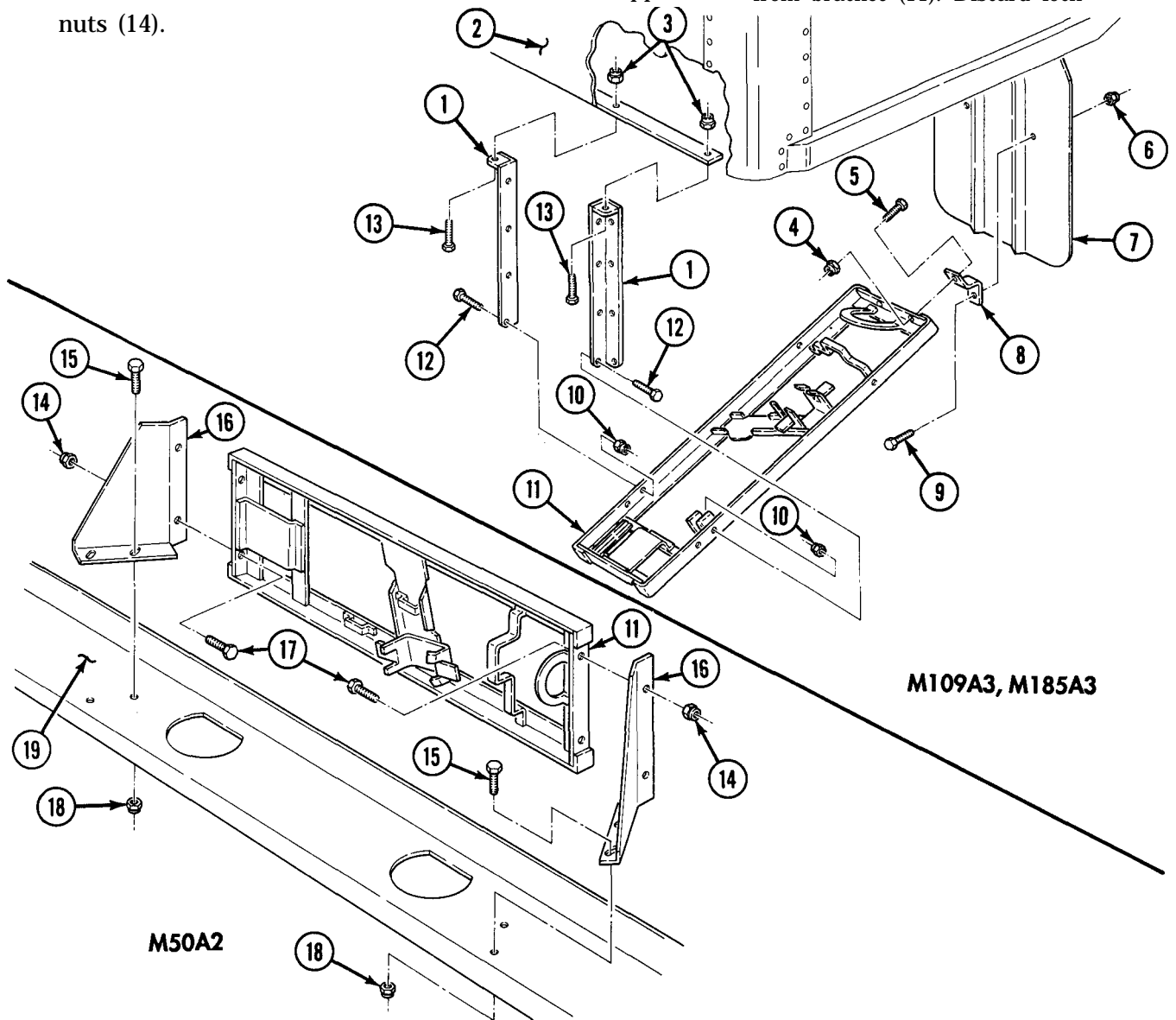

M109A3, M185A3

M50A2

**11-32. PIONEER TOOL BRACKET KIT REPLACEMENT (Contd)**

**NOTE**

Perform step 20 for M275A2 vehicles.

20. Remove four locknuts (20), screws (21), and bracket (11) from deckplate (22). Discard locknuts (20).

**NOTE**

Perform step 21 for M342A2 vehicles.

21. Remove four locknuts (23), screws (25), and bracket (11) from cab protector (24). Discard locknuts (23).

**b. Installation**

**NOTE**

Perform step 1 for M342A2 vehicles.

1. Install bracket (11) on cab protector (24) with four screws (25) and new locknuts (23).

**NOTE**

Perform step 2 for M275A2 vehicles.

2. Install bracket (11) on deck plate (22) with four screws (21) and new locknuts (20).

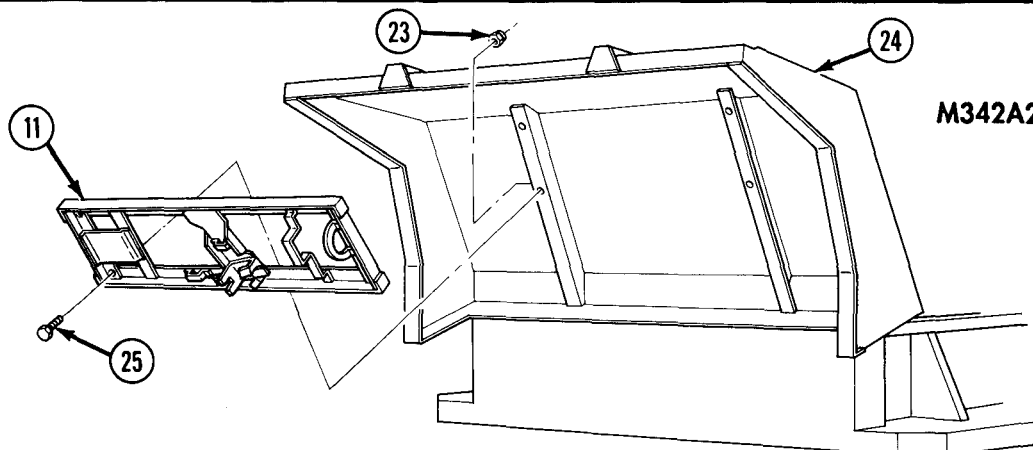
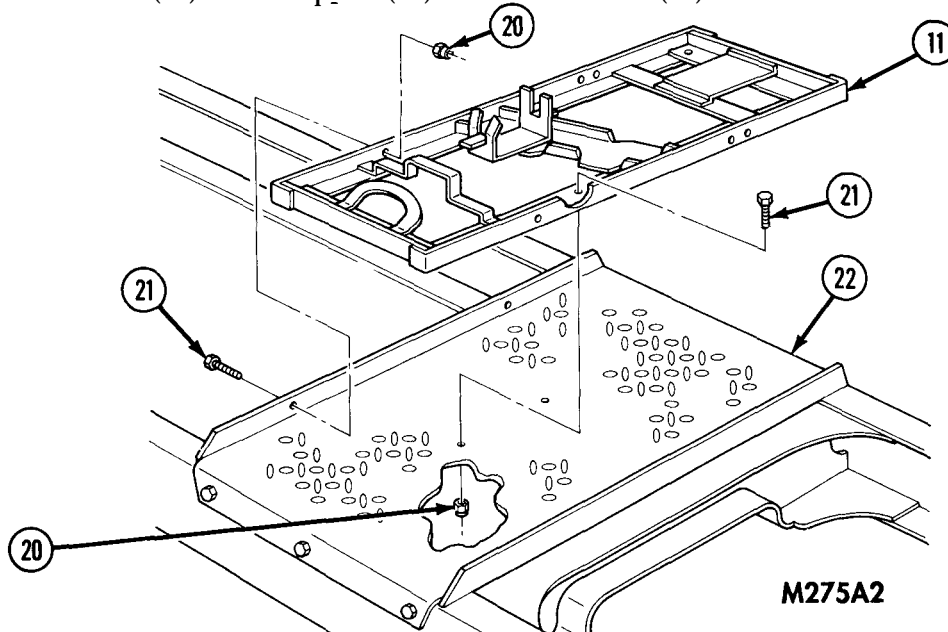

11-32. PIONEER TOOL BRACKET KIT REPLACEMENT (Contd)

**NOTE**

Perform steps 3 through 5 for M50A2 vehicles.

3. Install two supports (2) on bracket (3) with four screws (4) and new locknuts (5). Do not tighten locknuts (5).
4. Install bracket (3) with supports (2) on crossmember (7) with four screws (1) and new locknuts (6).
5. Tighten locknuts (5).

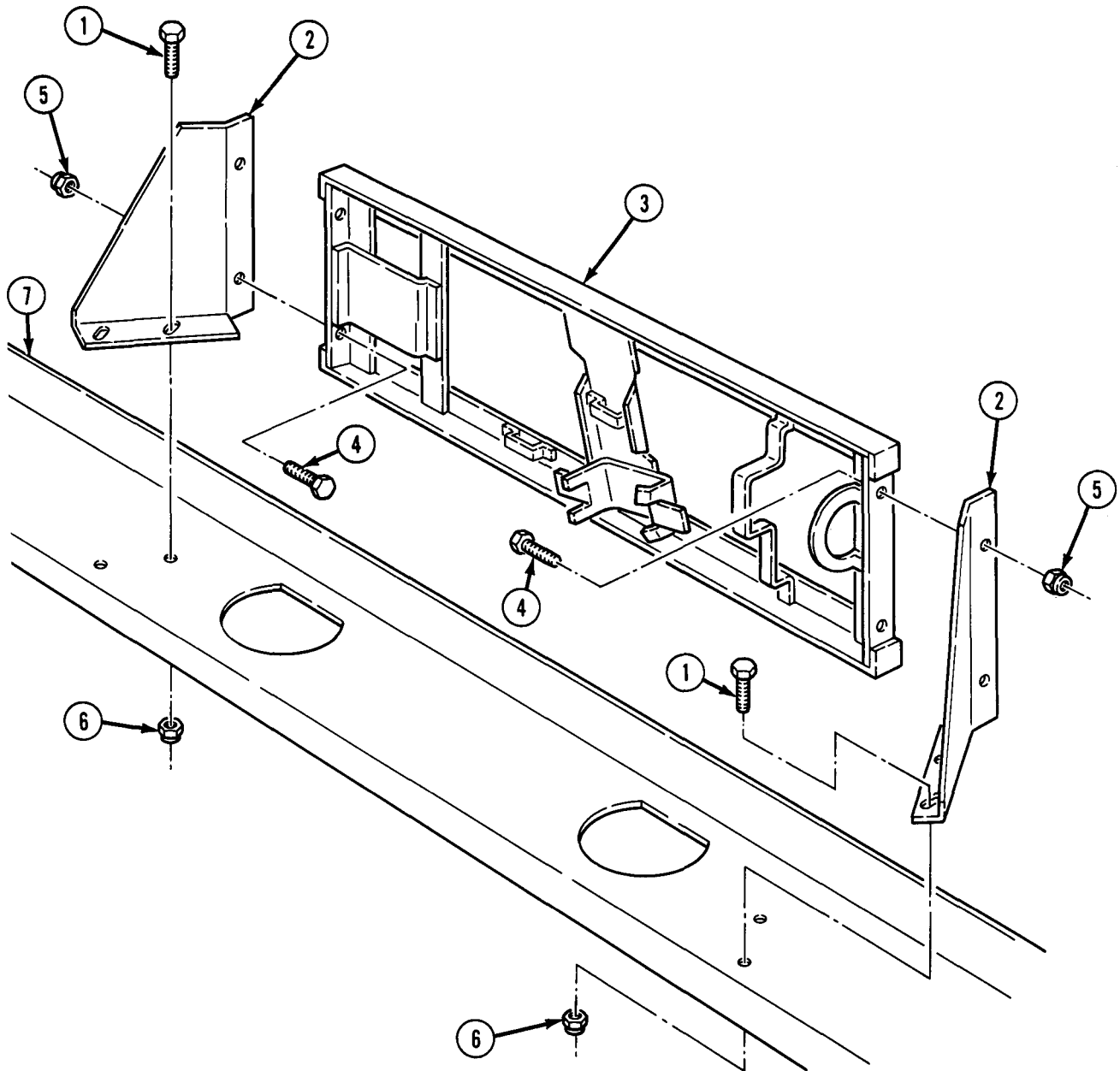

M50A2

## 11-32. PIONEER TOOL BRACKET KIT REPLACEMENT (Contd)

### NOTE

Perform steps 6 through 10 for M109A3 and M185A3 vehicles.

6. Install two supports (10) on van body sill (8) with two screws (19) and new locknuts (9). Do not tighten locknuts (9).
7. Install two supports (16) on bracket (3) with two screws (13) and new locknuts (12).
8. Install bracket (3) on supports (10) with two screws (11) and new locknuts (18). Do not tighten locknuts (18).
9. Install two supports (16) on front splash shield (15) with two screws (17) and new locknuts (14).
10. Tighten locknuts (9) and (18).

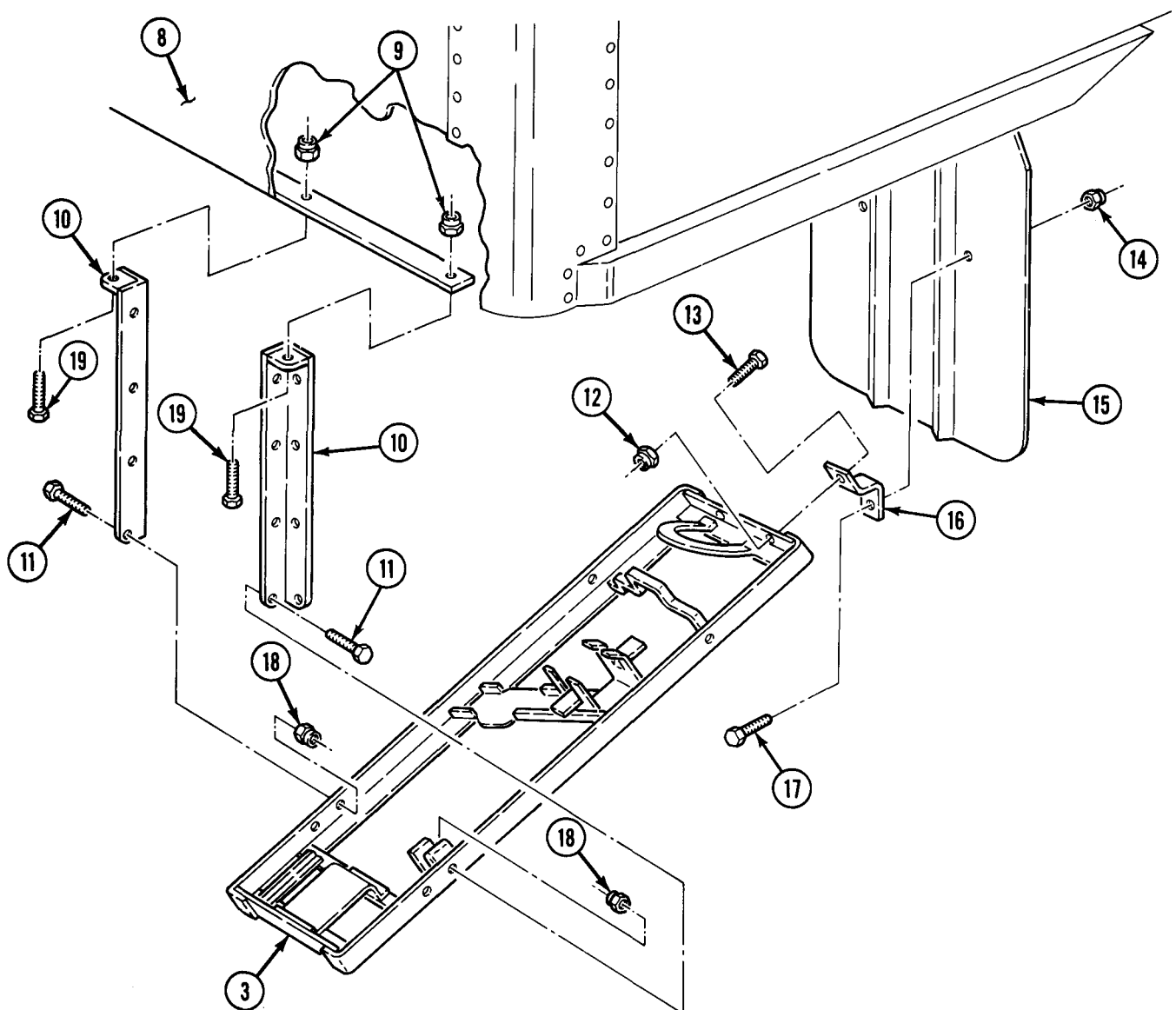

**M109A3, M185A3**



11-32. PIONEER TOOL BRACKET KIT REPLACEMENT (Contd)

**NOTE**

Perform steps 11 through 14 for M49A2C and M56A3 vehicles.

11. Install two supports (9) on front tank body sill (1) with two screws (2) and new locknuts (10). Do not tighten locknuts (10).
12. Install bracket (7) on two supports (9) with screws (8) and new locknuts (6). Do not tighten locknuts (6).
13. Install bracket (7) on front splash shield support (4) with two screws (3) and new locknuts (5).
14. Tighten locknuts (10) and (6).

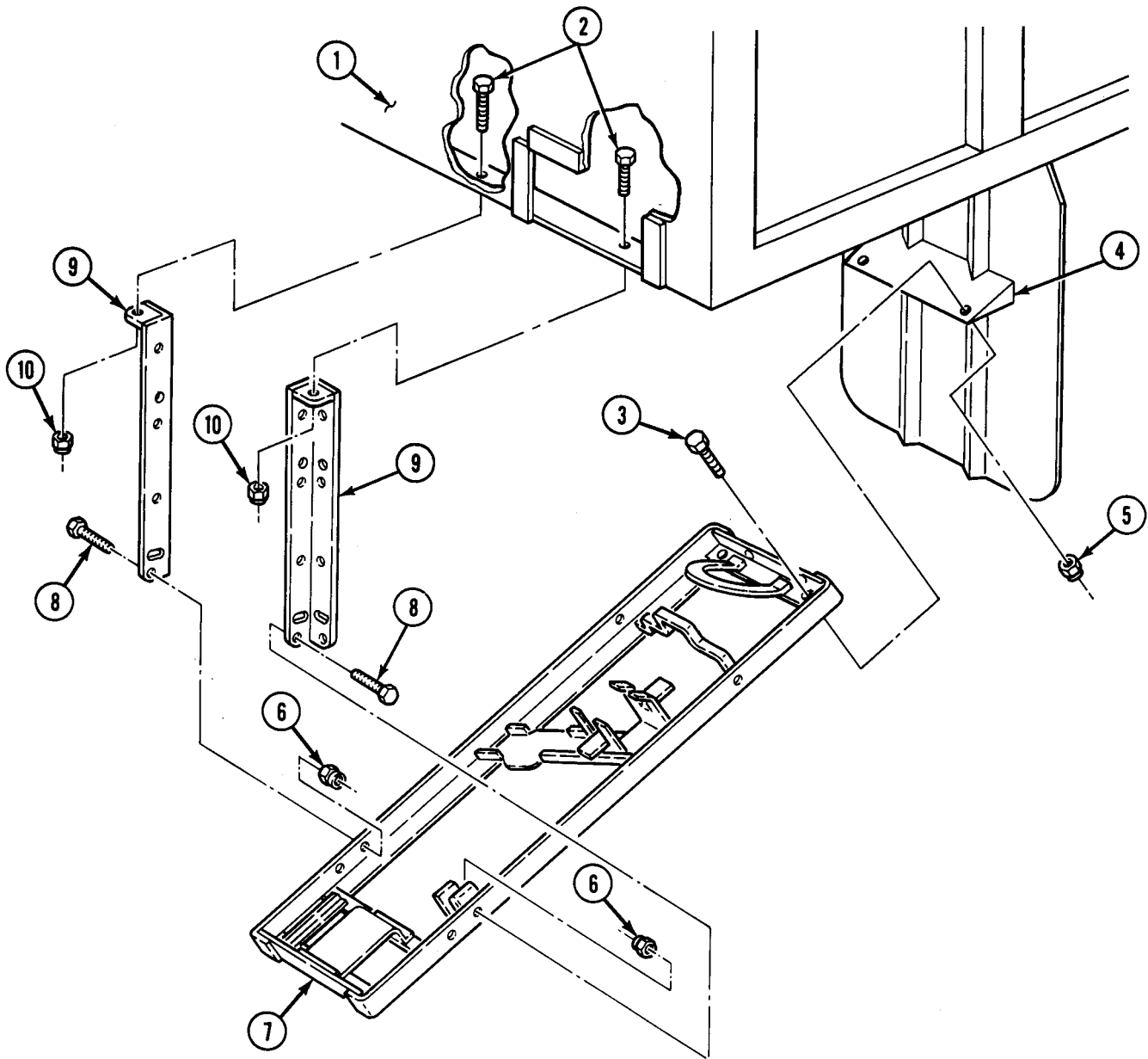

M49A2C, M56A3

## 11-32. PIONEER TOOL BRACKET KIT REPLACEMENT (Contd)

### NOTE

Perform steps 15 through 21 for M36A2 vehicles.

15. Install two supports (12) on supports (9) with four screws (26) and new locknuts (25). Do not tighten locknuts (25).
16. Install two supports (12) on supports (9) with screws (15) and new locknuts (24). Do not tighten locknuts (24).
17. Install two supports (12) on cargo bed crossmember (13) with two screws (11) and new locknuts (14). Do not tighten locknuts (14).
18. Install support (20) on bracket (7) with two screws (17) and new locknuts (16).
19. Install bracket (7) on two supports (9) with screws (23) and new locknuts (22). Do not tighten locknuts (22).
20. Install support (20) on front splash shield (19) with two screws (21) and new locknuts (18).
21. Tighten locknuts (25), (24), (14), (16), and (22).

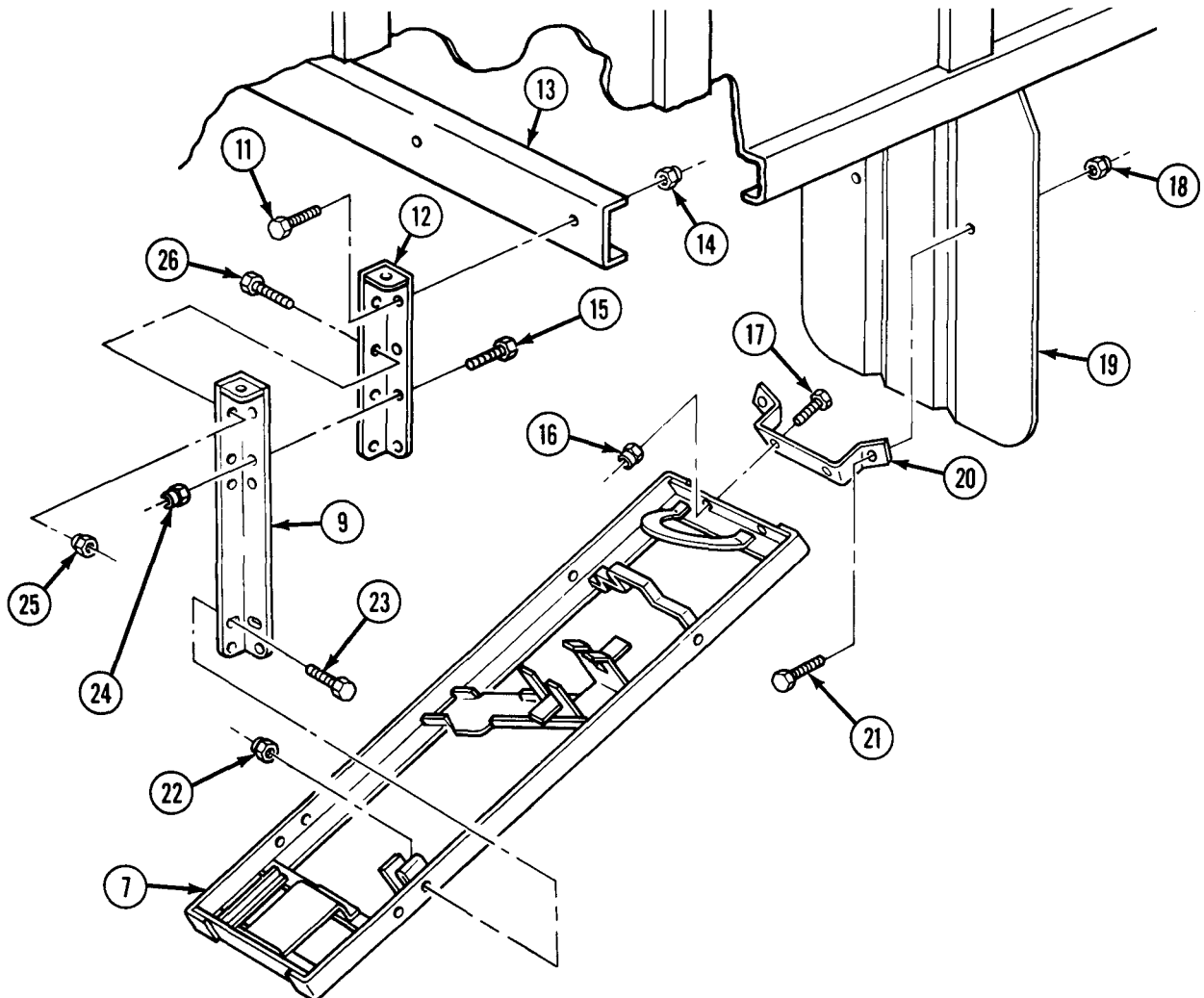

**M36A2**

11-32. PIONEER TOOL BRACKET KIT REPLACEMENT (Contd)

**NOTE**

Perform steps 22 through 26 for M35A2 and M35A2C vehicles.

22. Install two supports (3) on cargo bed sill (1) with two screws (13) and new locknuts (2). Do not tighten locknuts (2).
23. Install support (9) on bracket (12) with two screws (6) and new locknuts (5).
24. Install bracket (12) on two supports (3) with screws (4) and new locknuts (11). Do not tighten locknuts (11).
25. Install support (9) on front splash shield (8) with two screws (10) and new locknuts (7).
26. Tighten locknuts (2) and (11).

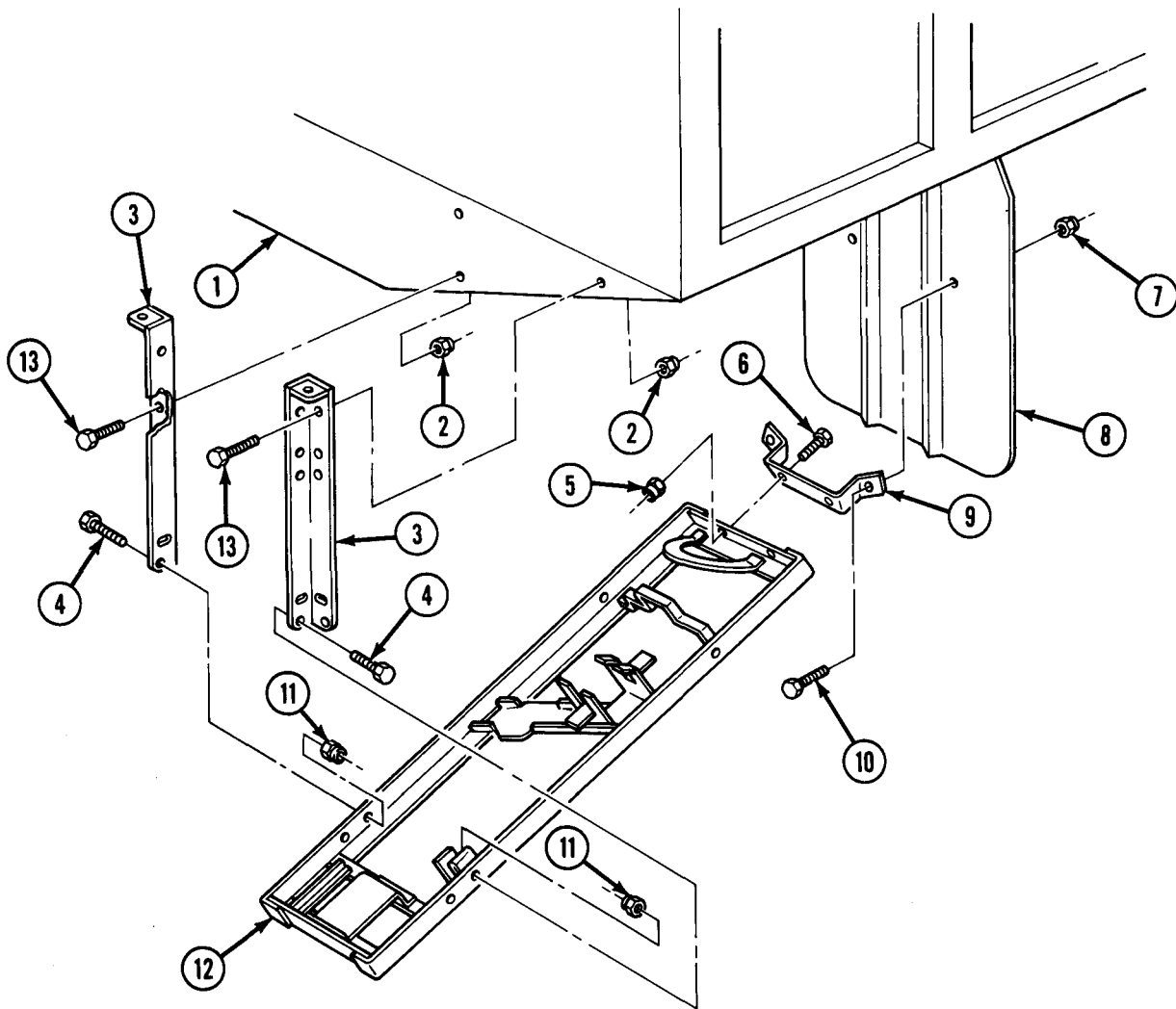

**11-33. WINDSHIELD WIPER MOTOR AIR TUBES REPLACEMENT**

This task covers:

**a. Removal**

**b. Installation**

INITIAL SETUP:

APPLICABLE MODELS

All

EQUIPMENT CONDITION

- Parking brake set (TM 9-2320-361-10).
- Air reservoir drained (TM 9-2320-361-10).

REFERENCES (TM)

- TM 9-2320-361-10
- TM 9-2320-361-20P

**a. Removal**

1. Compress two clamps (4) and remove hose (13) from copper tube (3) and fitting (12).
2. Remove three screws (1) and clamps (2) from windshield outer frame (8). Compress clamp (4) and remove copper tube (3) from hose (5).
3. Compress three clamps (4) and remove hoses (5), (6), and (10) from tee (11).
4. Remove screw (1) and clamp (9) from windshield outer frame (8). Compress two clamps (4) and remove hoses (10) and (6) from windshield wiper motors (7).

**b. Installation**

1. Compress two clamps (4) and install hoses (10) and (6) on windshield wiper motors (7). Install clamp (9) on hose (6) and windshield outer frame (8) with screw (1).
2. Compress three clamps (4) and install hoses (5), (6), and (10) on tee (11).
3. Compress clamps (4) and install copper tube (3) on hose (5). Install three clamps (2) on copper tube (3) and windshield outer frame (8) with three screws (1).
4. Compress two clamps (4) and install hose (13) on copper tube (3) and fitting (12).

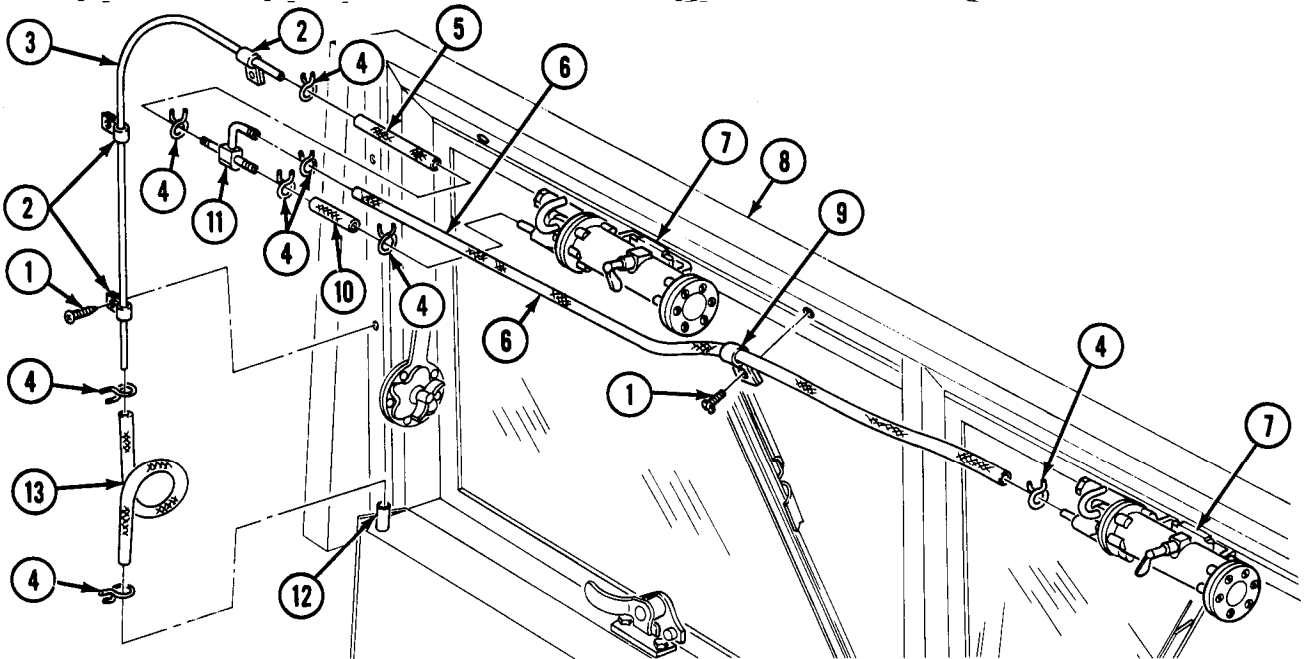

FOLLOW-ON TASK: Start engine, check for leaks (TM 9-2320-361-10).

## 11-34. WINDSHIELD WIPER BLADE, ARM, AND MOTOR REPLACEMENT

This task covers:

- |                                   |  |
|-----------------------------------|--|
| a. Windshield Wiper Blade Removal | d. Windshield Wiper Motor Installation |
| b. Windshield Wiper Arm Removal   | e. Windshield Wiper Arm Installation   |
| c. Windshield Wiper Motor Removal | f. Windshield Wiper Blade Installation |

INITIAL SETUP:

APPLICABLE MODELS

All

REFERENCES (TM)

TM 9-2320-361-10

TM 9-2320-361-20P

EQUIPMENT CONDITION

- Parking brake set (TM 9-2320-361-10).
- Air reservoirs drained (TM 9-2320-361-10).

### a. Windshield Wiper Blade Removal

Remove windshield wiper blade (4) from windshield wiper arm (3).

### b. Windshield Wiper Arm Removal

Remove nut (2) and windshield wiper arm (3) from windshield wiper motor (5).

### c. Windshield Wiper Motor Removal

1. Compress hose clamp (6) and disconnect hose (7) from windshield wiper motor (5).
2. Remove two screws (1) and windshield wiper motor (5) from windshield inner frame (8).

### d. Windshield Wiper Motor Installation

1. Install windshield wiper motor (5) on windshield inner frame (8) with two screws (1).
2. Connect hose (7) to windshield wiper motor (5) with hose clamp (6).

### e. Windshield Wiper Arm Installation

Install windshield wiper arm (3) on windshield wiper motor (5) with nut (2).

### f. Windshield Wiper Blade Installation

Install windshield wiper blade (4) on windshield wiper arm (3).

11-34. WINDSHIELD WIPER BLADE, ARM, AND MOTOR REPLACEMENT (Contd)

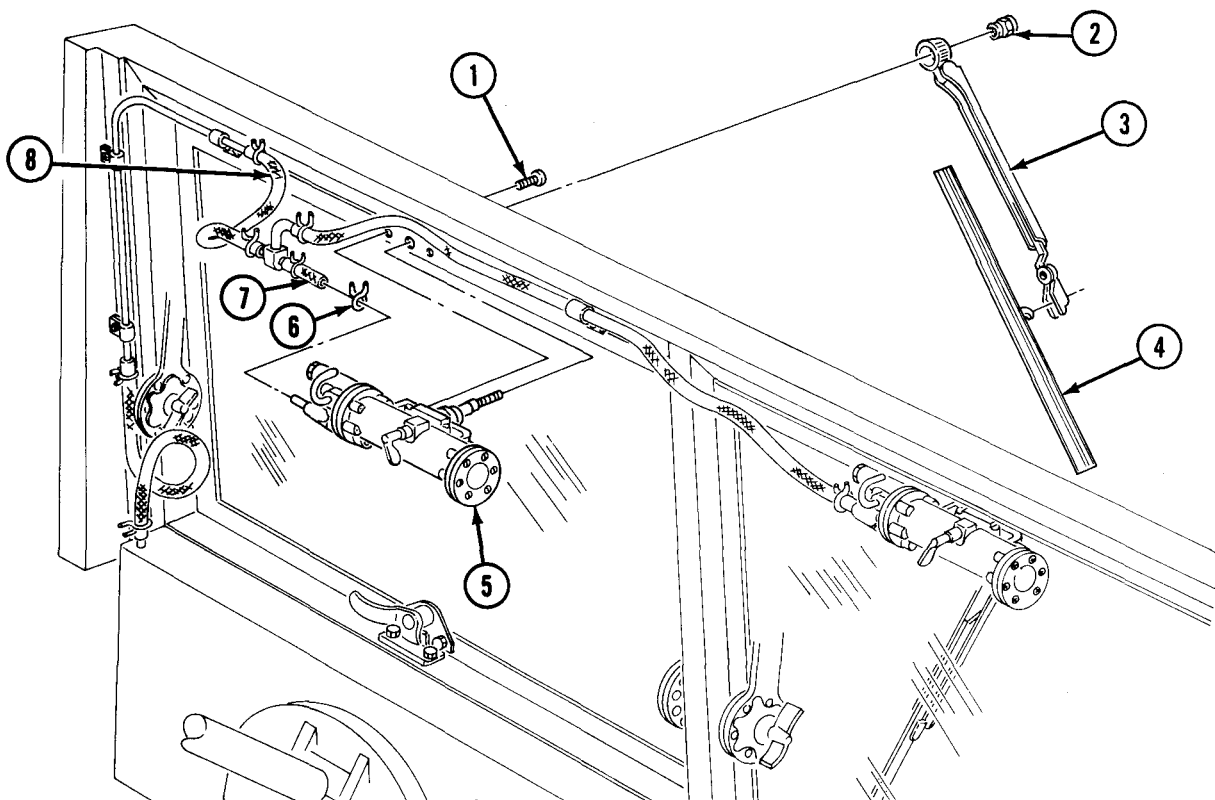

FOLLOW-ON TASK: Start engine. Check for leaks (TM 9-2320-361-10).

**11-35. WINDSHIELD WASHER RESERVOIR, TUBING, JET, AND PUMP REPLACEMENT**

This task covers:

- |   |   |
|---|---|
| <p>a. Windshield Washer Reservoir Removal<br/>                 b. Windshield Washer Tubing Removal<br/>                 c. Windshield Washer Jet Removal<br/>                 d. Windshield Washer Pump Removal</p> | <p>e. Windshield Washer Pump Installation<br/>                 f. Windshield Washer Jet Installation<br/>                 g. Windshield Washer Tubing Installation<br/>                 h. Windshield Washer Reservoir Installation</p> |
|---|---|

**INITIAL SETUP:**

APPLICABLE MODELS

All

MATERIALS/PARTS

Four locknuts

REFERENCES (TM)

TM 9-2320-361-10

TM 9-2320-361-20P

EQUIPMENT CONDITION

- Parking brake set (TM 9-2320-361-10).
- Hood raised and secured (TM 9-2320-361-10).

**a. Windshield Washer Reservoir Removal**

1. Remove cover (17) with grommet (16) from reservoir (19). Remove strainer (18) from hose (7) and hose (7) from grommet (16) and cover (17).
2. Remove three locknuts (24), two clamps (23), plate (22), two screws (21), washers (20), and reservoir (19) from steering column (25). Discard locknuts (24).

**b. Windshield Washer Tubing Removal**

**NOTE**

Tag hose and tubes for installation.

1. Disconnect tubes (4), (6), and (28) from valve (29).
2. Disconnect hose (7) and tubes (6) and (9) from tee connector (8).
3. Remove grommet (27) and hose (7) from dash panel (26).

**c. Windshield Washer Jet Removal**

Remove nut (5), washer (2), and jet (3) from cowling (1).

**d. Windshield Washer Pump Removal**

Remove locknut (10), washer (11), windshield washer pump (13), washer (14), and screw (15) from instrument panel (12). Discard locknut (10).

**e. Windshield Washer Pump Installation**

Install windshield washer pump (13) on instrument panel (12) with washer (14), screw (15), washer (11), and new locknut (10).

**f. Windshield Washer Jet Installation**

Install washer (2) and jet (3) on cowling (1) with nut (5).

## 11-35. WINDSHIELD WASHER RESERVOIR, TUBING, JET, AND PUMP REPLACEMENT (Contd)

### g. Windshield Washer Tubing Installation

1. Install grommet (27) and hose (7) on dash panel (26).
2. Install tubing (28) on jet (3) and install tubing (4) and (9) on pump (13).
3. Install hose (7) and tubing (9) and (6) on tee connector (8).
4. Install tubing (4), (6), and (28) on valve (29).

### h. Windshield Washer Reservoir Installation

1. Install two clamps (23) on steering column (25).
2. Install plate (22) and reservoir (19) on clamps (23) with three screws (21), washers (20), and new locknuts (24).
3. Install grommet (16) in cover (17).
4. Install tube (7) through grommet (16) and connect to strainer (18). Position strainer (18) at bottom of reservoir (19) and install cover (17) on reservoir (19).

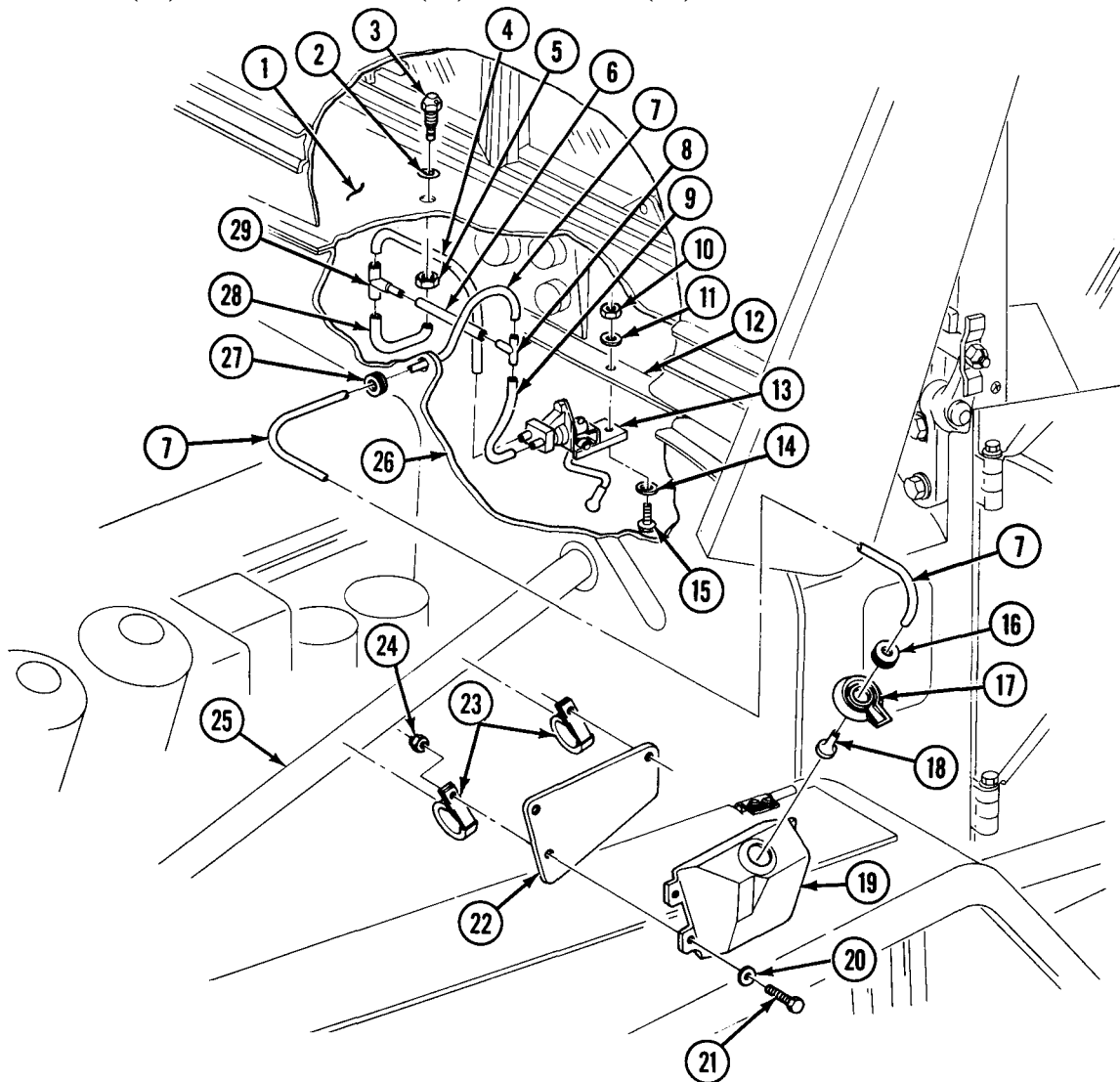



**11-36. MIRROR AND BRACKETS REPLACEMENT**

**This task covers:**

**a. Removal**

**b. Installation**

INITIAL SETUP:

APPLICABLE MODELS

All

MATERIALS/PARTS

Ten locknuts

Screw-assembled lockwasher

REFERENCES (TM)

TM 9-2320-361-10

TM 9-2320-361-20P

EQUIPMENT CONDITION

Parking brake set (TM 9-2320-361-10).

**a. Removal**

1. Remove screw-assembled washer (26), convex mirror (17), locknut (16), washer (15), two brackets (23), and screw (25) from brace (24). Discard locknut (16) and screw-assembled washer (26).
2. Remove two locknuts (18), washers (19), spacers (20), and mirror (21) from bracket (22). Discard locknuts (18).
3. Remove two locknuts (10), four washers (11) and (14), rod (30), brace (24), and bracket (22) from braces (12), (13), (27), (28), and (29). Discard locknuts (10).
4. Remove locknut (7), washer (6), hinge bolt (9), and braces (13) and (27) from upper door hinge (5). Discard locknut (7).
5. Install hinge bolt (9) in upper door hinge (5).
6. Remove locknut (7), washer (6), hinge bolt (9), and brace (29) from top of lower door hinge (31). Discard locknut (7).
7. Install hinge bolt (9) in lower door hinge (31).
8. Remove locknut (7), washer (6), screw (8), and braces (12) and (28) from clip (4). Discard locknut (7).
9. Remove two locknuts (1), plate (2), clip (4), and screws (32) from cowling (3). Discard locknuts (1).

**b. Installation**

1. Install clip (4) and plate (2) on cowling (3) with two screws (32) and new locknuts (1).
2. Install braces (12) and (28) on clip (4) with screw (8), washer (6), and new locknut (7).
3. Remove hinge bolt (9) from lower door hinge (31).
4. Install brace (29) on top of lower door hinge (31) with hinge bolt (9), washer (6), and new locknut (7).
5. Remove hinge bolt (9) from upper door hinge (5).
6. Install braces (13) and (27) on upper door hinge (5) with hinge bolt (9), washer (6), and new locknut (7).
7. Install bracket (22), brace (24), and rod (30) on braces (12), (13), (27), (28), and (29) with four washers (11) and (14) and two new locknuts (10).

11-36. MIRROR AND BRACKETS REPLACEMENT (Contd)

8. Install two spacers (20) on mirror (21) and install mirror (21) on bracket (22) with two washers (19) and new locknuts (18).
9. Install convex mirror (17) on brace (24) with two brackets (23), screw (25), washer (15), new locknut (16), and new screw-assembled washer (26).

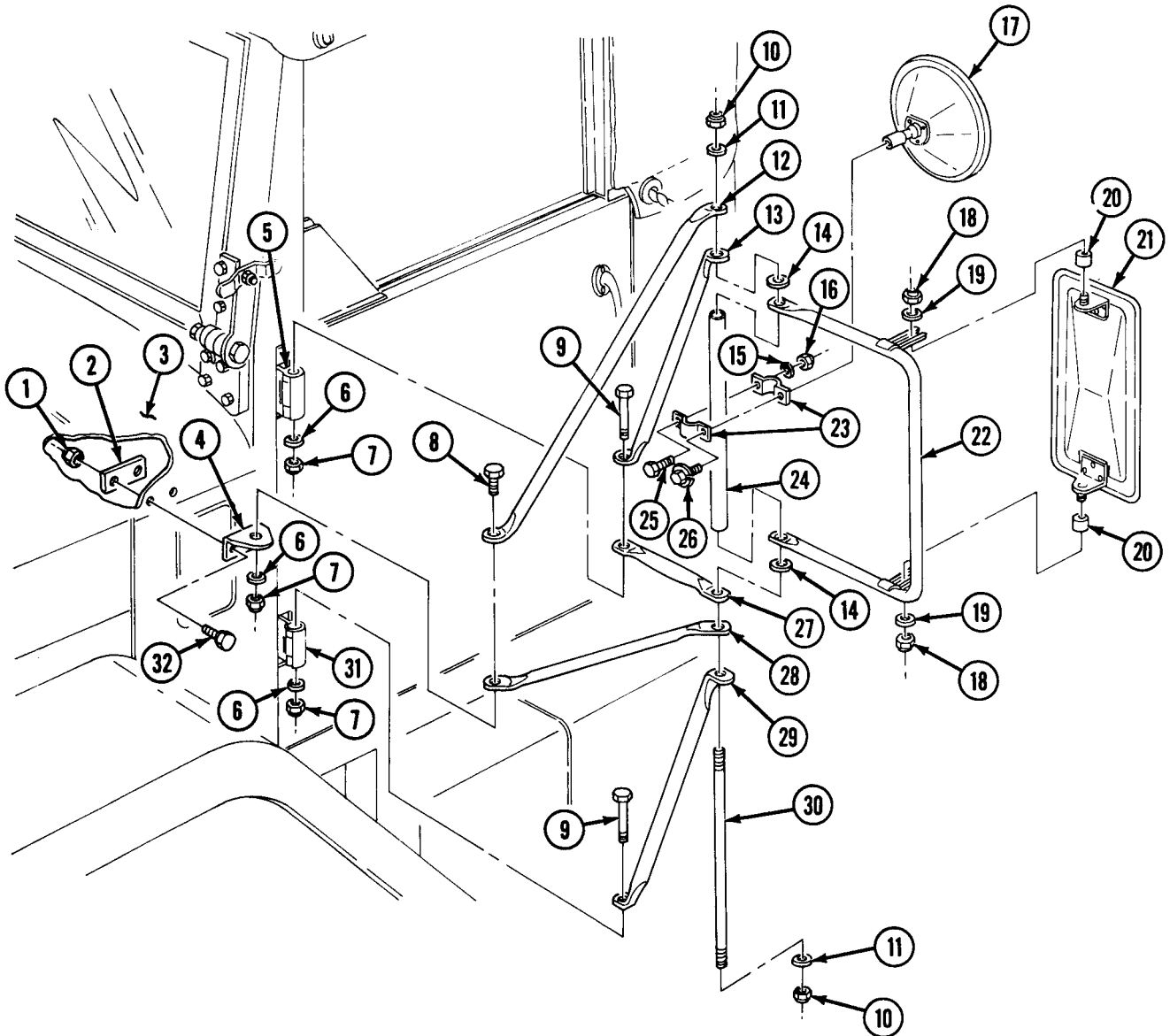

## 11-37. DATA PLATE REPLACEMENT

**This task covers**

**a. Removal**

**b. Installation**

**INITIAL SETUP:**

APPLICABLE MODELS

All

REFERENCES (TM)

TM 9-2320-361-10

TM 9-2320-361-20P

MATERIALS/PARTS

Four drivescrews

EQUIPMENT CONDITION

Parking brake set (TM 9-2320-361-10).

**NOTE**

- Data plates are installed with rivets, screws, drivescrews, or adhesive. This procedure covers a data plate installed with drivescrews.
- All data plate replacement procedures are basically the same. This procedure covers a front winch data plate replacement.

**a. Removal**

Remove four drivescrews (3) and data plate (2) from support (1). Discard drivescrews (3).

**b. Installation**

Install data plate (2) on support (1) with four new drivescrews (3).

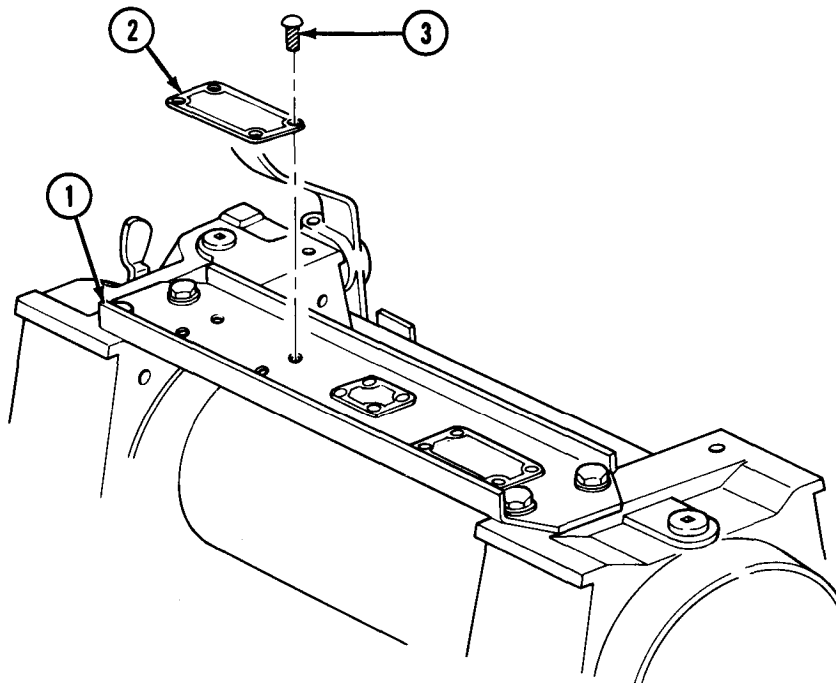

**11-38. PERSONNEL HEATER SUPPLY HOSE REPLACEMENT**

This task covers:

**a. Removal**

**b. Installation**

INITIAL SETUP:

APPLICABLE MODELS

All

EQUIPMENT CONDITION

Parking brake set (TM 9-2320-361-10).

REFERENCES (TM)

TM 9-2320-361-10

TM 9-2320-361-20P

**a. Removal**

1. Loosen clamp (5) and remove supply hose (4) from air vent (1).
2. Loosen clamp (3) and remove supply hose (4) from diverter (2).

**b. Installation**

1. Install supply hose (4) on diverter (2) with clamp (3). Tighten clamp (3).
2. Connect supply hose (4) on air vent (1) with clamp (5). Tighten clamp (5).

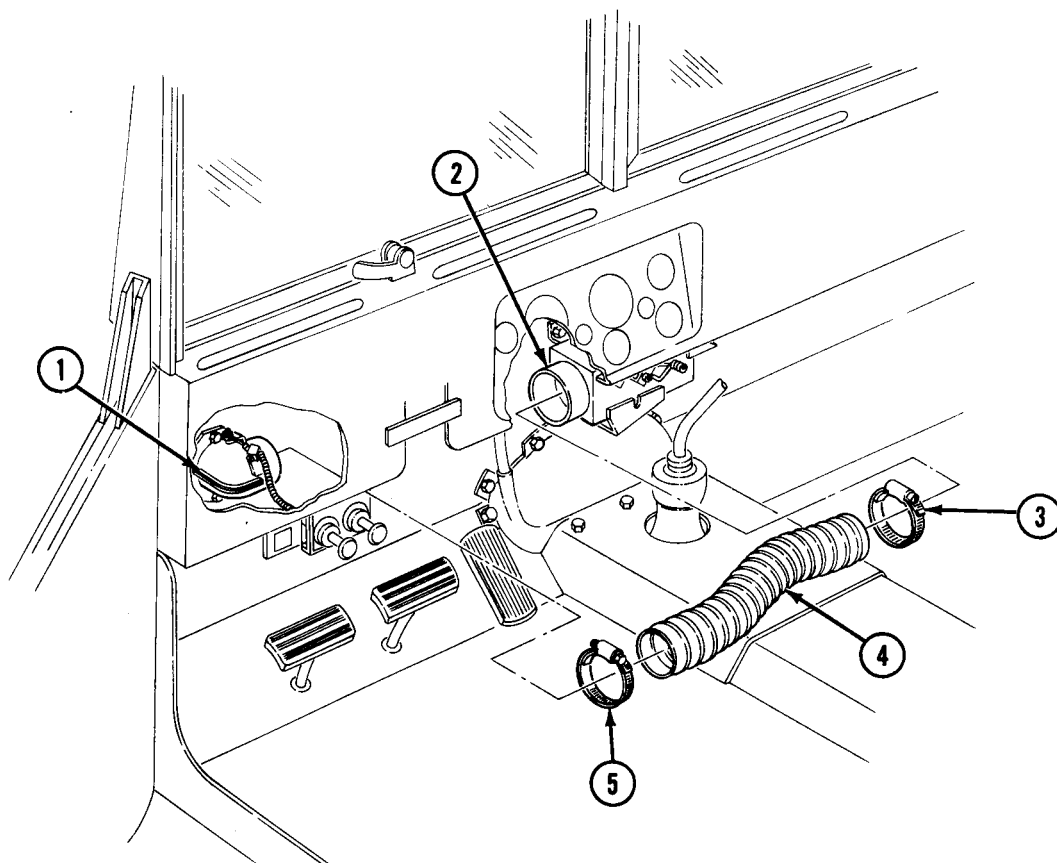

## 11-39. PERSONNEL HEATER DIVERTER REPLACEMENT

This task covers:

**a. Removal**

**b. Installation**

INITIAL SETUP:

APPLICABLE MODELS

All

MATERIALS/PARTS

Four lockwashers

REFERENCES (TM)

TM 9-2320-361-10

TM 9-2320-361-20P

EQUIPMENT CONDITION

Parking brake set (TM 9-2320-361-10).

### a. Removal

1. Loosen clamp (11) and disconnect supply hose (13) from diverter (9).
2. Loosen two clamps (4) and disconnect two defroster hoses (3) from diverter (9).
3. Loosen screw (7) and holddown clamp (8) and disconnect cable (10) from shaft handle (6).
4. Remove four nuts (1), lockwashers (2), screws (5), and diverter (9) from firewall (12). Discard lockwashers (2).

### b. Installation

1. Install diverter (9) on firewall (12) with four screws (5), new lockwashers (2), and nuts (1).
2. Install cable (10) through holddown clamp (8) and on shaft handle (6). Tighten holddown clamp (8) with screw (7).
3. Install two defroster hoses (3) on diverter (9) with two clamps (4).
4. Install supply hose (13) on diverter (9) with clamp (11).

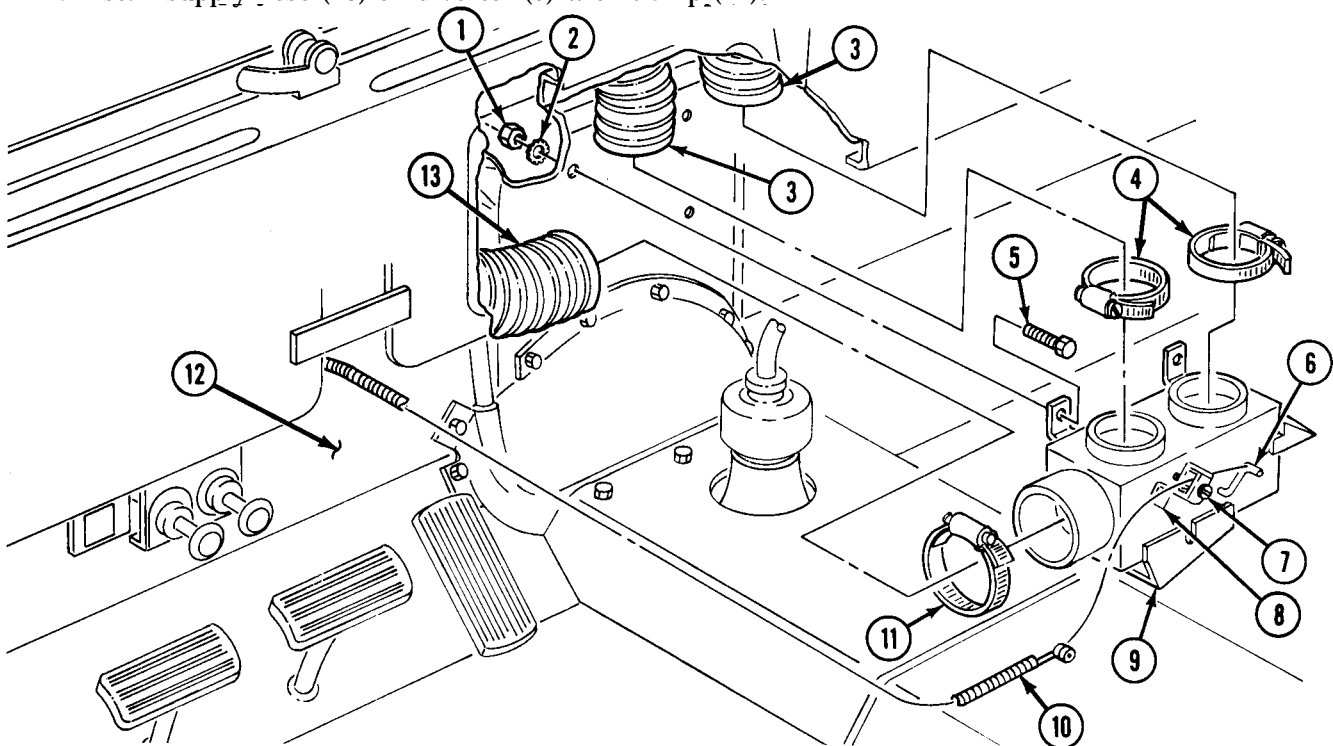

FOLLOW-ON TASK: Adjust control cable (para. 11-41).

## 11-40. PERSONNEL HEATER AIR VENT REPLACEMENT

This task covers:

### a. Removal

### b. Installation

INITIAL SETUP:

#### APPLICABLE MODELS

All

#### REFERENCES (TM)

TM 9-2320-361-10

TM 9-2320-361-20P

#### MATERIALS/PARTS

Four lockwashers

#### EQUIPMENT CONDITION

Parking brake set (TM 9-2320-361-10).

### a. Removal

1. Loosen clamp (4) and remove supply hose (1) from air vent (9).
2. Loosen screw (8) and remove cable (5) from shaft (2) and clamp (3).
3. Remove two nuts (6), lockwashers (7), screws (12), lockwashers (11), and air vent (9) from fire-wall (10). Discard lockwashers (7) and (11).

### b. Installation

1. Install air vent (9) on firewall (10) with two new lockwashers (11), screws (12), new lockwashers (7), and nuts (6).
2. Insert cable (5) through clamp (3) and install on shaft (2) with screw (8).
3. Install supply hose (1) on air vent (9) with clamp (4). Tighten clamp (4).

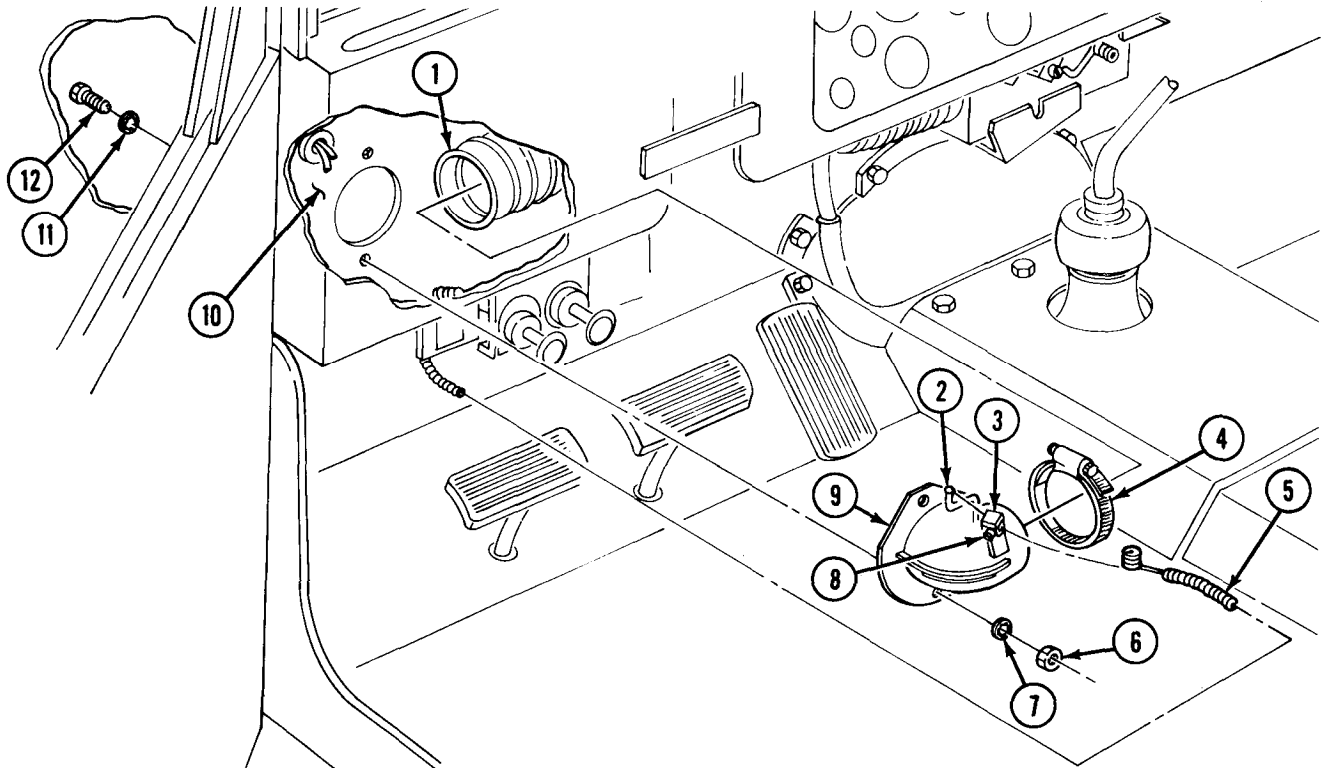

FOLLOW-ON TASK: Adjust control cable (para. 11-41).

<b>11-41. PERSONNEL HEATER CONTROL CABLES REPLACEMENT</b>
---

**This task covers:**

- a. Removal**
- b. Installation**

- c. Adjustment**

**INITIAL SETUP:**

APPLICABLE MODELS

All

MATERIALS/PARTS

Four lockwashers

REFERENCES (TM)

TM 9-2320-361-10

TM 9-2320-361-20P

EQUIPMENT CONDITION

Parking brake set (TM 9-2320-361-10).

<b>a. Removal</b>
-------------------

1. Loosen screw (6) and remove cable (7) from shaft (5) and clamp (4) on diverter (3).
2. Loosen screw (16) and remove cable (8) from shaft (18) and clamp (19) on adapter (17).
3. Remove two nuts (1), lockwashers (2), screws (10), and bracket (9) from instrument panel (15). Discard lockwashers (2).
4. Remove nut (13), lockwasher (11), and cable (8) from bracket (9). Discard lockwasher (11).
5. Remove nut (14), lockwasher (12), and cable (7) from bracket (9). Discard lockwasher (12).

<b>b. Installation</b>
------------------------

1. Install cable (7) in bracket (9) with new lockwasher (12) and nut (14).
2. Install cable (8) in bracket (9) with new lockwasher (11) and nut (13).
3. Install bracket (9) to instrument panel (15) with two screws (10), new lockwashers (2), and nuts (1).
4. Insert cable (8) through clamp (19) and install on shaft (18) of adapter (17).
5. Insert cable (7) through clamp (4) and install on shaft (5) of diverter (3).

<b>c. Adjustment</b>
----------------------

1. Loosen screw (16) and slide cable (8) through clamp (19).
2. Push shaft (18) of adapter (17) forward and tighten screw (16).
3. Loosen screw (6) and slide cable (7) through clamp (4).
4. Push shaft (5) of diverter (3) to the right, and tighten screw (6).

11-41. PERSONNEL HEATER CONTROL CABLES REPLACEMENT (Contd)

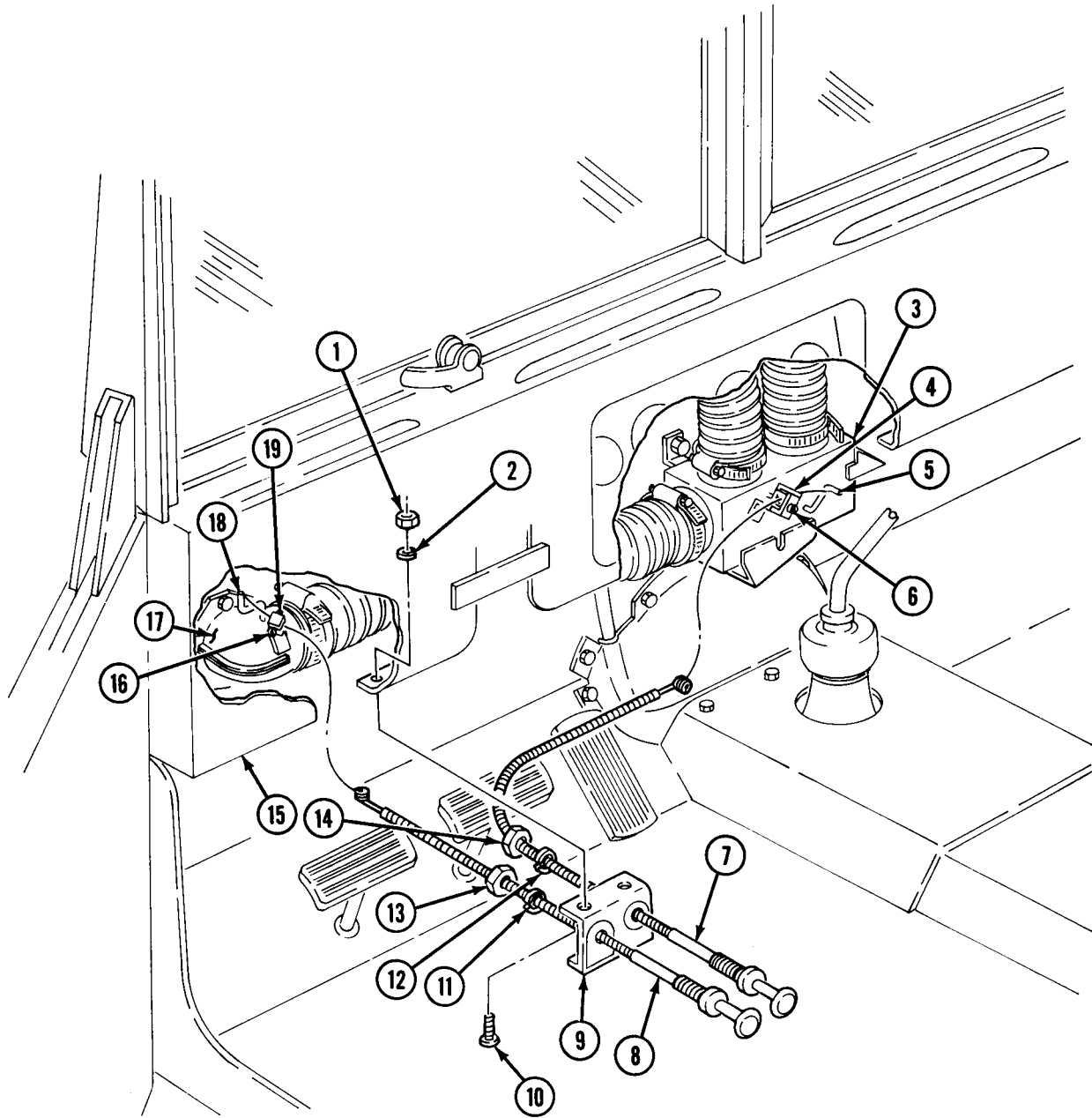



## 11-42. PERSONNEL HOT WATER HEATER REPLACEMENT

This task covers

- a. Hoses and Adapters Removal
- b. Heater Removal
- c. Brackets Removal

- d. Brackets Installation
- e. Heater Installation
- f. Hoses and Adapters Installation

### INITIAL SETUP:

#### APPLICABLE MODELS

All

#### MATERIALS/PARTS

Fourteen locknuts  
Twelve lockwashers

#### REFERENCES (TM)

TM 9-2320-361-10  
TM 9-2320-361-20P

#### EQUIPMENT CONDITION

- Parking brake set (TM 9-2320-361-10).
- Hood raised and secured (TM 9-2320-361-10).
- Battery ground cable disconnected (para. 4-47).
- Two engine coolant heater hoses removed (para. 3-44).

### NOTE

In some installations, fresh air hood, screen, and elbow are mounted on left side panel.

#### **a. Hoses and Adapters Removal**

1. Loosen two clamps (1) and remove inlet hose (14) from elbow (24) and adapter (17).
2. Loosen two clamps (1) and remove outlet hose (13) from adapters (9) and (12).
3. Remove eight screws (11), lockwashers (10), and adapter (12) from heater (4). Discard lockwashers (10).
4. Remove four screws (15), lockwashers (16), and adapter (17) from heater (4). Discard lockwashers (16).
5. Remove three locknuts (2), elbow (24), screen (23), hood (20), and three screws (19) from hood side panel (21). Discard locknuts (2).

#### **b. Heater Removal**

1. Disconnect electrical plugs (5).
2. Remove screw (7), clamp (6), and wire (8) from heater (4).
3. Remove four locknuts (18), heater (4), and screws (3) from bracket (22). Discard locknuts (18).

11-42. PERSONNEL HOT WATER HEATER REPLACEMENT (Contd)

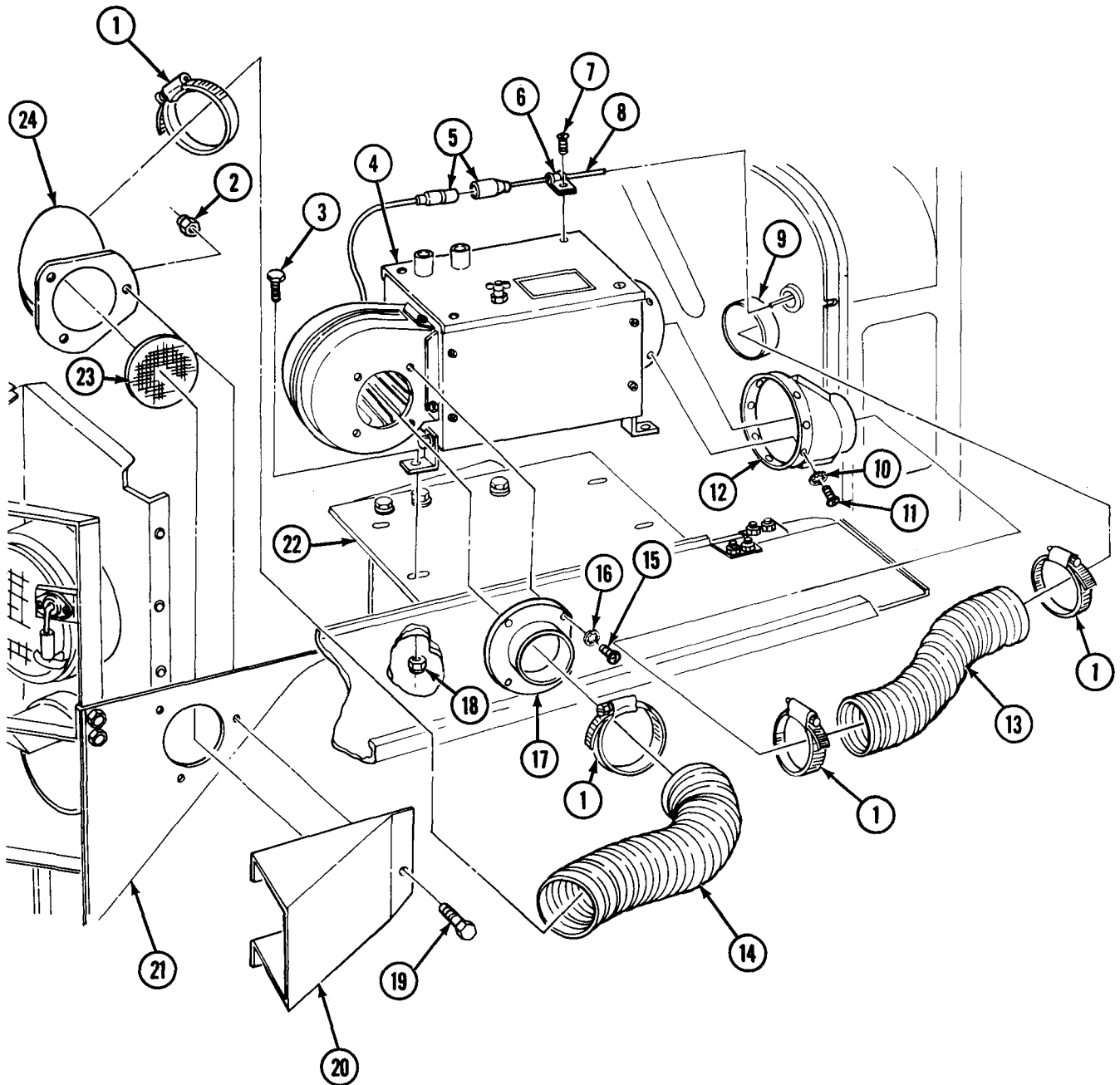

## 11-42. PERSONNEL HOT WATER HEATER REPLACEMENT (Contd)

### c. Brackets Removal

1. Remove five locknuts (1), ten washers (2), five screws (6), and bracket (5) from fender (13) and bracket (4). Discard locknuts (1).
2. Remove two locknuts (1), four washers (2), bracket (4), and two screws (3) from frame (14). Discard locknuts (1).

### d. Brackets Installation

1. Install bracket (4) on frame (14) with two screws (3), four washers (2), and two new locknuts (1).
2. Install bracket (5) on fender (13) and bracket (4) with five screws (6), ten washers (2), and five new locknuts (1).

### e. Heater Installation

1. Install heater (7) on bracket (5) with four screws (12) and new locknuts (1).
2. Install wire (11) and clamp (9) on heater (7) with screw (10).
3. Connect electrical plugs (8).

11-42. PERSONNEL HOT WATER HEATER REPLACEMENT (Contd)

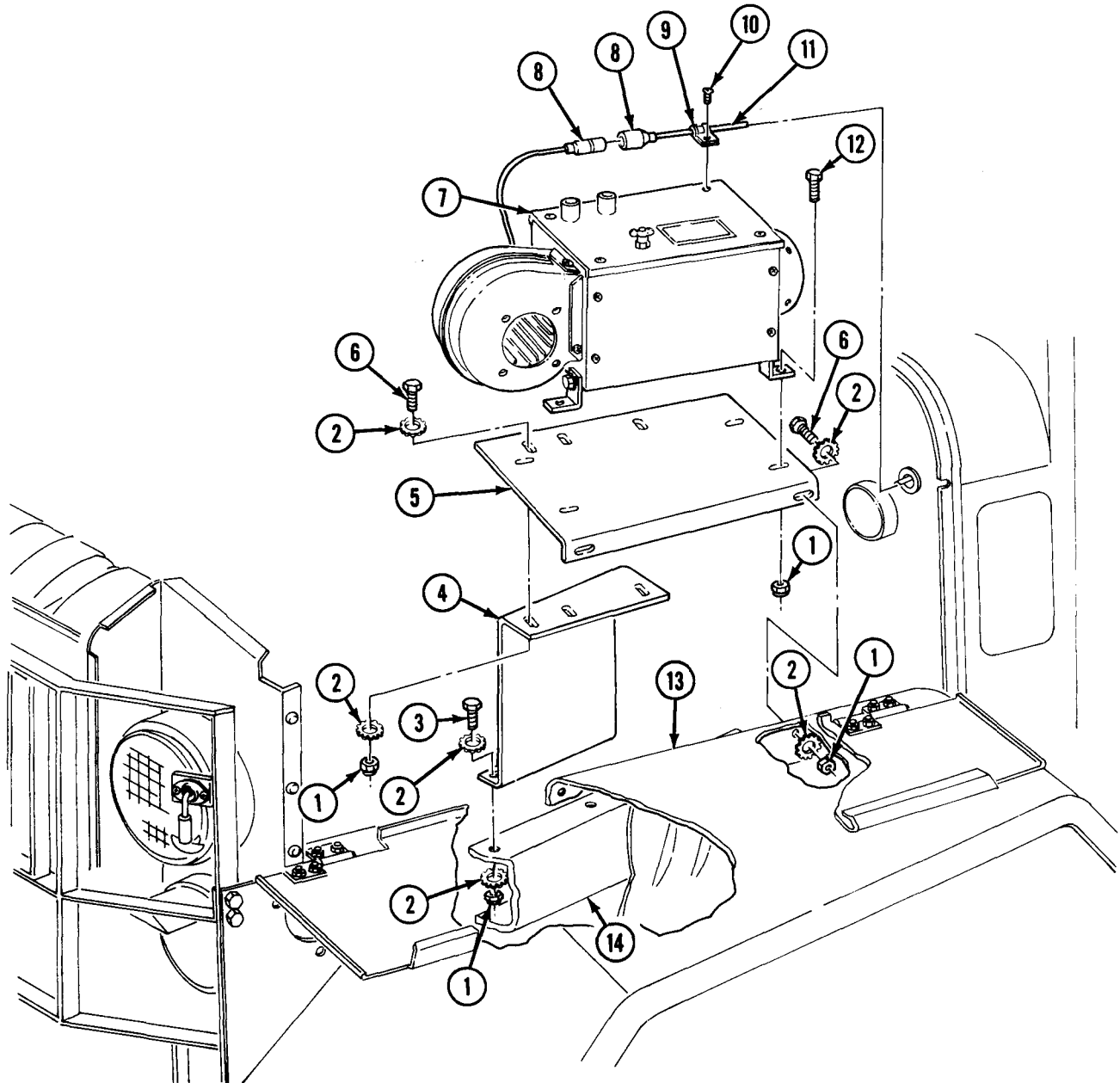

11-42. PERSONNEL HOT WATER HEATER REPLACEMENT (Contd)

f. Hoses and Adapters Installation

1. Install screen (17), elbow (1), and hood (15) on hood side panel (16) with three screws (14) and new locknuts (3).
2. Install adapter (13) on heater (4) with four screws (11) and new lockwashers (12).
3. Install adapter (5) on heater (4) with eight screws (8) and new lockwashers (7).
4. Install outlet hose (9) on adapters (5) and (6) with two clamps (2).
5. Install inlet hose (10) on adapter (13) and elbow (1) with two clamps (2).

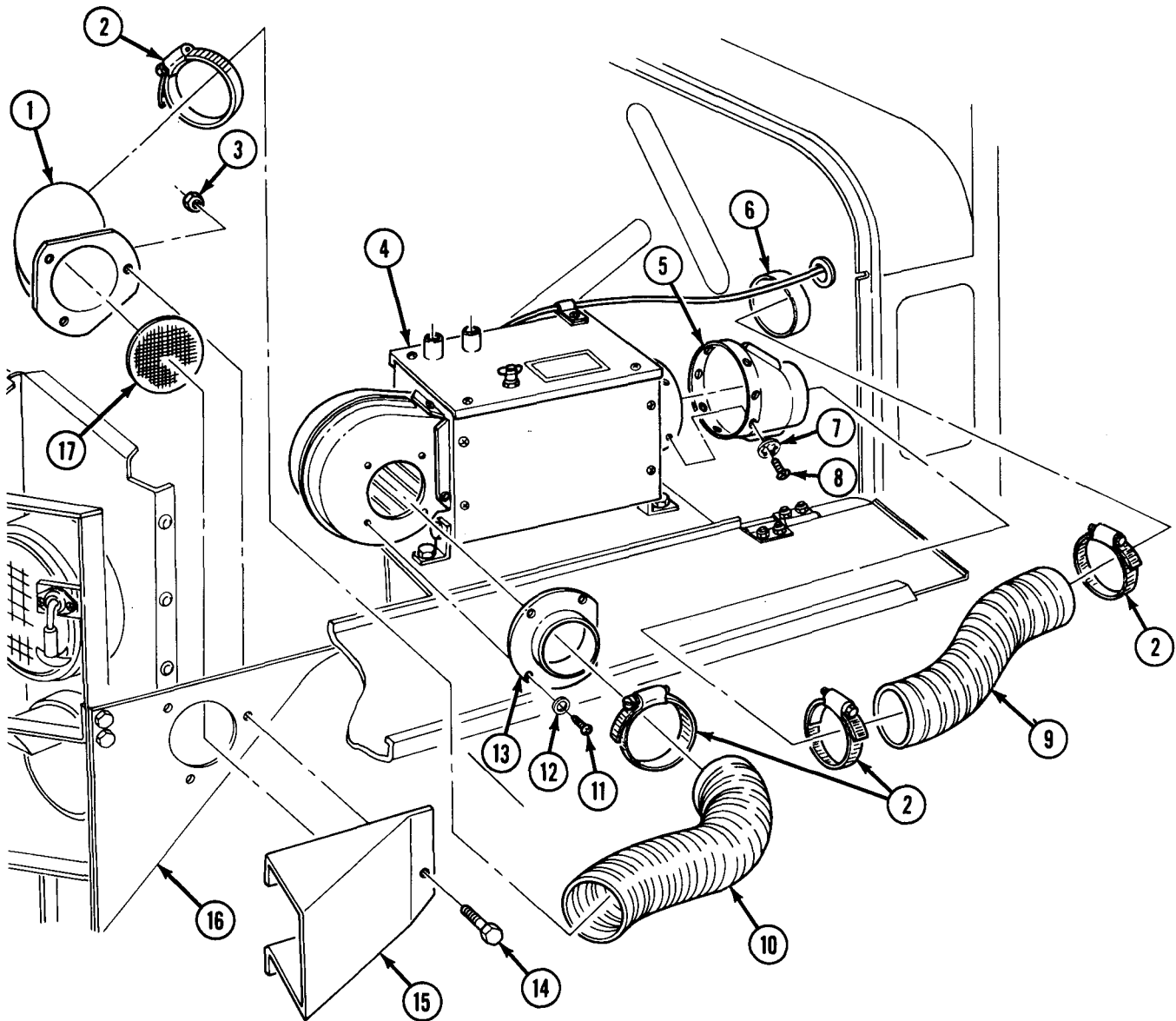

FOLLOW-ON TASKS: • Install coolant heater hoses (para. 3-44).  
 • Connect battery ground cable (para. 4-48).

## 11-43. PERSONNEL HEATER DEFROSTER HOSES REPLACEMENT

This task covers:

### a. Removal

### b. Installation

INITIAL SETUP:

#### APPLICABLE MODELS

All

#### EQUIPMENT CONDITION

Parking brake set (TM 9-2320-361-10).

#### REFERENCES (TM)

TM 9-2320-361-10

TM 9-2320-361-20P

### a. Removal

1. Loosen clamp (4) and remove defroster hose (3) from diverter (2).
2. Loosen clamp (5) and remove defroster hose (3) from defroster duct (1).

### b. Installation

1. Install defroster hose (3) on defroster duct (1) with clamp (5).
2. Install defroster hose (3) on diverter (2) with clamp (4).

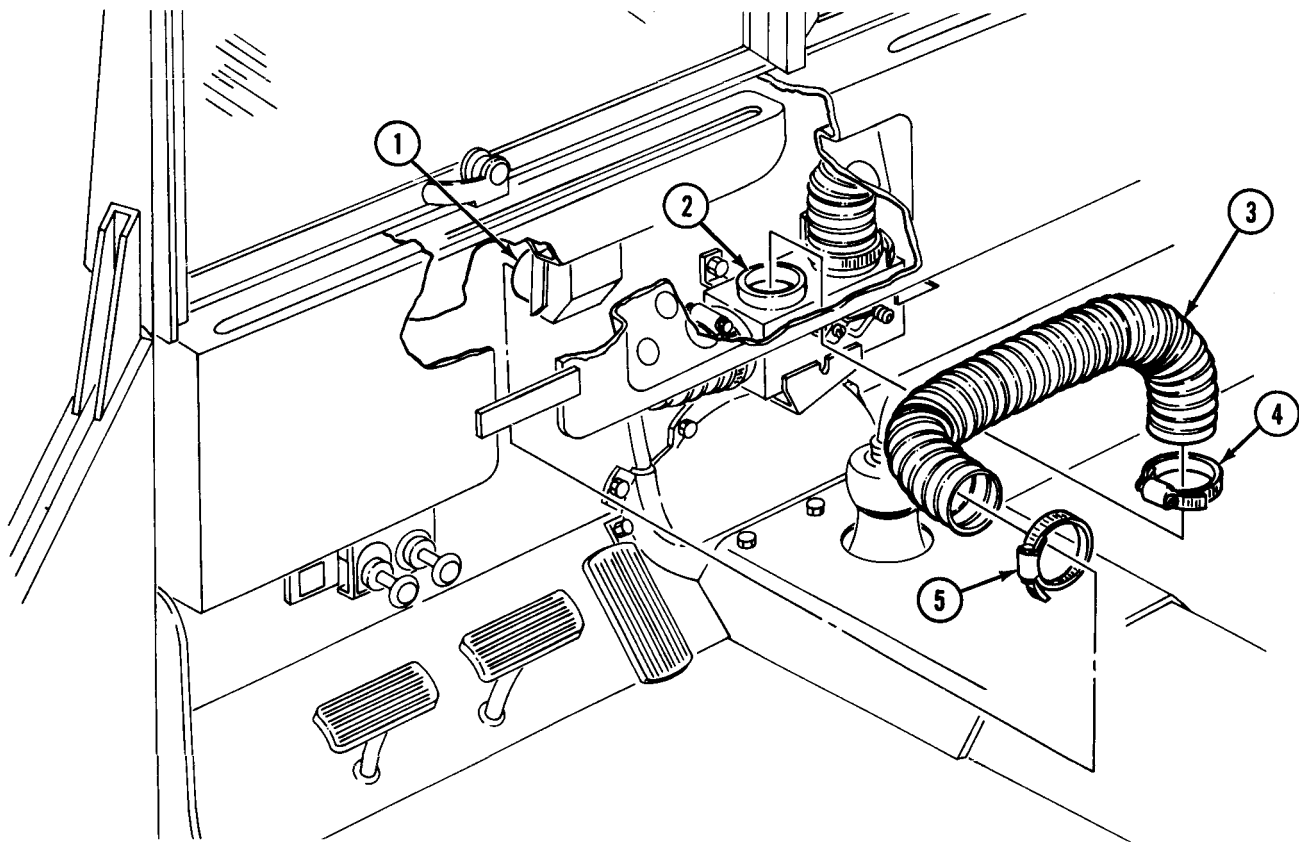

11-44. REFLECTOR REPLACEMENT

This task covers:

**a. Removal**

**b. Installation**

INITIAL SETUP:

APPLICABLE MODELS

All

REFERENCES (TM)

TM 9-2320-361-10

TM 9-2320-361-20P

MATERIALS/PARTS

Six locknuts

EQUIPMENT CONDITION

Parking brake set (TM 9-2320-361-10).

**a. Removal**

1. Remove two locknuts (1), screws (4), and yellow reflector (3) from forward cargo body side (2). Discard locknuts (1).
2. Remove two locknuts (8), screws (5), and red reflector (6) from rear cargo body side (7). Discard locknuts (8).
3. Remove two locknuts (12), screws (11), and red reflector (10) from rear cargo body (9). Discard locknuts (12).

**b. Installation**

1. Install red reflector (10) on rear cargo body (9) with two screws (11) and new locknuts (12).
2. Install red reflector (6) on rear cargo body side (7) with two screws (5) and new locknuts (8).
3. Install yellow reflector (3) on forward cargo body side (2) with two screws (4) and new locknuts (1).

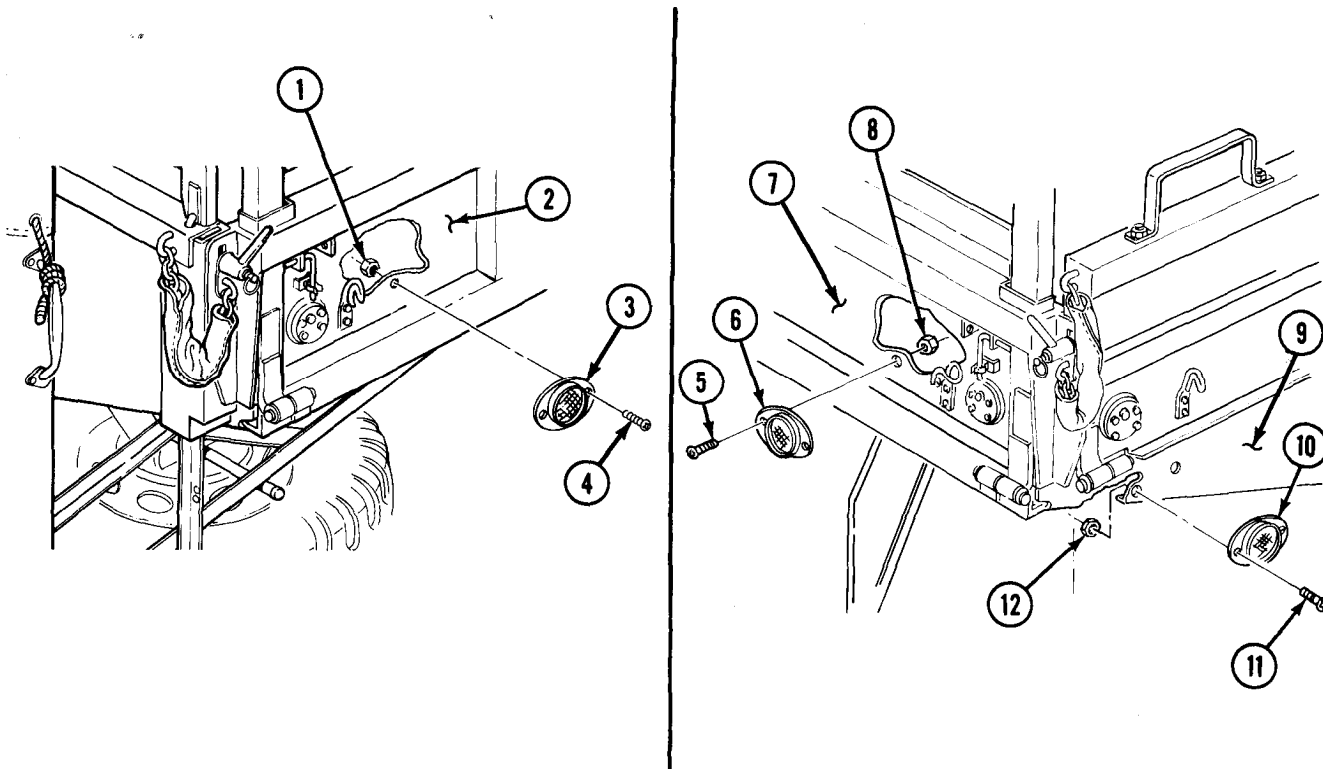

## CHAPTER 12 SPECIAL PURPOSE BODIES MAINTENANCE

- Section I. Cargo Body Maintenance (page 12-1)  
 Section II. Dump Body Maintenance (page 12-16)  
 Section III. Tank Body Maintenance (page 12-29)  
 Section IV. Van Body Maintenance (page 12-94)  
 Section V. Earthboring and Polesetting Truck Body Maintenance (page 12-132)  
 Section VI. Pipeline Construction Body Maintenance (page 12-165)  
 Section VII. Tractor Maintenance (page 12-177)

### Section I. CARGO BODY MAINTENANCE

#### 12-1. CARGO BODY MAINTENANCE INDEX

PARA. NO.	TITLE	PAGE NO.
12-2.	Cargo Body Rack and Troop Seat Maintenance	12-1
12-3.	Cargo Body Tailgate Replacement (M35A2, M36A2)	12-4
12-4.	Cargo Body Tailgate Replacement (M35A2C)	12-5
12-5.	Cargo Body Upper and Lower Rear Splash Guard Replacement (M35A2C)	12-6
12-6.	Front Splash Guard Replacement (M35A2C, M36A2)	12-8
12-7.	Cargo Body Front Rack Maintenance (M35A2C)	12-10
12-8.	Cargo Body Dropside Replacement (M35A2C)	12-12
12-9.	Cargo Body Front Rack Maintenance (M36A2)	12-14
12-10.	Cargo Bodies Tailgate Maintenance	12-15

#### 12-2. CARGO BODY RACK AND TROOP SEAT MAINTENANCE

This task covers:

- |  |  |
|--|--|
| <ul style="list-style-type: none"> <li>a. Troop Seat Removal</li> <li>b. Cargo Rack Disassembly</li> <li>c. Troop Seat Disassembly</li> <li>d. Inspection</li> </ul> | <ul style="list-style-type: none"> <li>e. Troop Seat Assembly</li> <li>f. Cargo Rack Assembly</li> <li>g. Troop Seat Installation</li> </ul> |
|--|--|

---

#### INITIAL SETUP:

##### APPLICABLE MODELS

M35A2, M35A2C, M36A2

##### MATERIALS/PARTS

Five cotter pins  
 Nine locknuts

##### REFERENCES (TM)

TM 9-2320-361-10  
 TM 9-2320-361-20P

##### EQUIPMENT CONDITION

- Parking brake set (TM 9-2320-361-10).
  - Troop seat and side rack removed (TM 9-2320-361-10).
-



## 12-2. CARGO BODY RACK AND TROOP SEAT MAINTENANCE (Contd)

### a. Troop Seat Removal

Remove five cotter pins (4), pins (3), and troop seat (2) from cargo rack (1). Discard cotter pins (4).

#### NOTE

M36A2 has side racks. Maintenance procedures for M36A2, M35A2, and M35A2C cargo body racks are the same. This procedure covers M35A2 and M35A2C.

### b. Cargo Rack Disassembly

1. Remove two locknuts (10), washers (8), clamps (7), washers (8), and screws (9) from cargo rack slats (5). Discard locknuts (10).
2. Remove sixteen nuts (12), screws (6), and five bow pockets (11) from two cargo rack slats (5).

### c. Troop Seat Disassembly

1. Remove five locknuts (13), screws (15), and legs (14) from three channels (18) and two end channels (20). Discard locknuts (13).
2. Remove two locknuts (23), screws (16), and hinges (21) from end channels (20). Discard locknuts (23).
3. Remove twenty-four nuts (22), screws (19), five hinges (21), two end channels (20), and three channels (18) from troop seat slats (17).

### d. Inspection

1. Inspect legs (14), channels (18) and (20), and hinges (21) for cracks, bends, and excessive rust. Replace legs (14), channels (18) and (20), or hinges (21) if cracked, bent, or excessively rusted.
2. Inspect wood slats (17) and (5) for splinters, warp, and excessive rotting. Replace slats (17) and (5) if splintered, warped, or excessively rotted.

### e. Troop Seat Assembly

1. Install two end channels (20), three channels (18), and five hinges (21) on slats (17) with twenty-four screws (19) and nuts (22).
2. Install two screws (16) and new locknuts (23) on end channels (20) and hinges (21).
3. Install leg (14) on three channels (18) and two end channels (20) with five screws (15) and new locknuts (13).

### f. Cargo Rack Assembly

1. Install five bow pockets (11) on two cargo rack slats (5) with sixteen screws (6) and nuts (12).
2. Install screws (9), washers (8), clamps (7), washers (8), and new locknuts (10) on two cargo rack slats (5).

### g. Troop Seat Installation

Install troop seat (2) on cargo rack (1) with five pins (3) and new cotter pins (4).

12-2. CARGO BODY RACK AND TROOP SEAT MAINTENANCE (Contd)

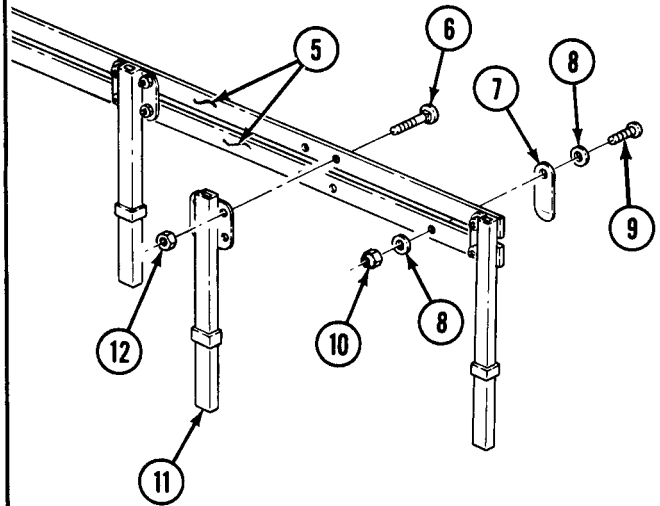
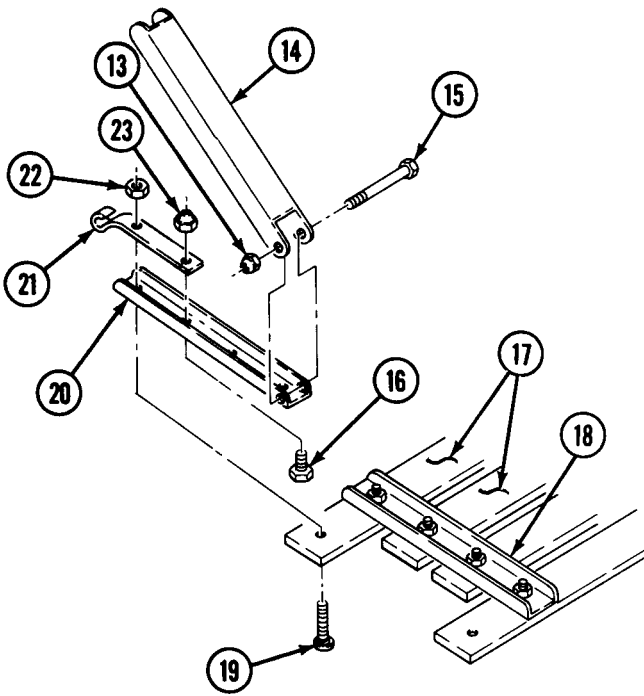
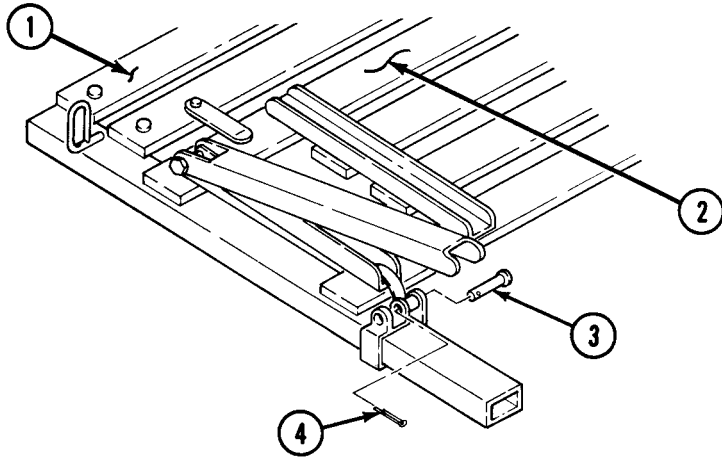

FOLLOW-ON TASK: Install troop seat and side rack (TM 9-2320-361-10).

## 12-3. CARGO BODY TAILGATE REPLACEMENT (M35A2, M36A2)

This task covers:

### a. Removal

### b. Installation

#### INITIAL SETUP:

##### APPLICABLE MODELS

M35A2, M36A2

##### MATERIALS/PARTS

Ten cotter pins

##### PERSONNEL REQUIRED

Two

##### REFERENCES (TM)

TM 9-2320-361-10

TM 9-2320-361-20P

##### EQUIPMENT CONDITION

Parking brake set (TM 9-2320-361-10).

##### GENERAL SAFETY INSTRUCTIONS

Direct all personnel to stand clear during lifting operations.

### a. Removal

1. Install chain sling (2) on tailgate (1).
2. Install lifting device (3) on chain sling (2) and raise lifting device (3) until slack is removed from chain sling (2).
3. Remove hook (8) from each side of tailgate (1).

### **WARNING**

All personnel must stand clear during lifting operations. A swinging or shifting load may result in injury to personnel.

4. Remove ten cotter pins (7), washers (6), and five pins (5) from hinges (4). Discard cotter pins (7).
5. Lower tailgate (1) to ground and remove chain sling (2).

### b. Installation

1. Attach chain sling (2) to tailgate (1) and lifting device (3) to chain sling (2).

#### **NOTE**

Assistant will help with steps 2 and 3.

2. Raise tailgate (1) and position on vehicle hinges (4).
3. Install tailgate (1) with five pins (5), ten washers (6), and ten new cotter pins (7).
4. Install hook (8) in each side of tailgate (1).
5. Remove lifting device (3) and chain sling (2) from tailgate (1).

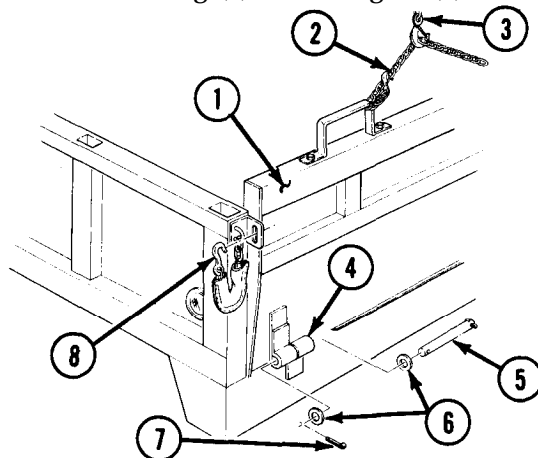

## 12-4. CARGO BODY TAILGATE REPLACEMENT (M35A2C)

This task covers:

### a. Removal

### b. Installation

#### INITIAL SETUP:

##### APPLICABLE MODELS

M35A2C

##### MATERIALS/PARTS

Eight cotter pins

##### PERSONNEL REQUIRED

Two

##### REFERENCES (TM)

TM 9-2320-361-10

TM 9-2320-361-20P

##### EQUIPMENT CONDITION

Parking brake set (TM 9-2320-361-10).

##### GENERAL SAFETY INSTRUCTIONS

All personnel must stand clear during lifting operations.

### a. Removal

1. Install chain sling (4) on tailgate (2) and attach lifting device (3) to chain sling (4).
2. Raise lifting device (3) until slack is removed from chain sling (4).
3. On each side of tailgate (2) loosen handle (9) and remove lockbar (10) from vehicle dropside(1).

### **WARNING**

All personnel must stand clear during lifting operations. A swinging or shifting load may cause injury to personnel.

4. Remove eight cotter pins (8), washers (7), and four pins (6) from hinges (5). Discard cotter pins (8).
5. Lower tailgate (2) to ground and remove lifting device (3) and chain sling (4).

### b. Installation

1. Attach chain sling (4) to tailgate (2) and lifting device (3) to chain sling (4).

### **NOTE**

Assistant will help with steps 2 and 3.

2. Raise tailgate (2) and position on vehicle hinges (5).
3. Install tailgate (2) with four pins (6), eight washers (7), and eight new cotter pins (8).
4. On each side of tailgate (2), install lockbar (10) and tighten handle (9) on vehicle dropside (1).
5. Remove lifting device (3) and chain sling (4) from tailgate (2).

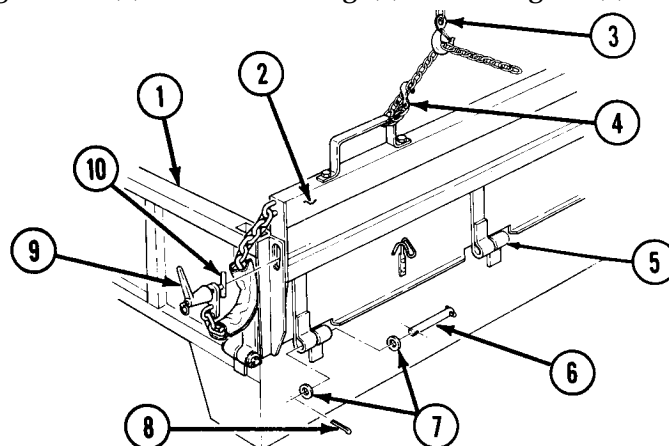

**12-5. CARGO BODY UPPER AND LOWER REAR SPLASH GUARD REPLACEMENT  
(M35A2C)**

This task covers:

- a. Lower Splash Guard Removal
- b. Upper Splash Guard Removal
- c. Upper Splash Guard Installation
- d. Lower Splash Guard Installation

**INITIAL SETUP:**

APPLICABLE MODELS

M35A2C

MATERIALS/PARTS

Thirteen locknuts

REFERENCES (TM)

TM 9-2320-361-10

TM 9-2320-361-20P

EQUIPMENT CONDITION

Parking brake set (TM 9-2320-361-10).

**a. Lower Splash Guard Removal**

Remove five locknuts (8), screws (11), retaining strip (9), and lower splash guard (10) from upper splash guard (7). Discard locknuts (8).

**b. Upper Splash Guard Removal**

1. Remove two locknuts (6) and screws (12) from upper splash guard braces (16) and upper splash guard (7). Discard locknuts (6).
2. Remove two locknuts (3), screws (4), and braces (16) from frame (5). Discard locknuts (3).
3. Remove two locknuts (18) and screws (2) from top of upper splash guard (7) and frame (1). Remove upper splash guard (7). Discard locknuts (18).
4. Remove two locknuts (13), screws (17), bumper (15), and plate (14) from upper splash guard (7). Discard locknuts (13).

**c. Upper Splash Guard Installation**

1. Install plate (14) and bumper (15) on upper splash guard (7) with two screws (17) and new locknuts (13).
2. Install upper splash guard (7) on frame (1) with two screws (2) and new locknuts (18).
3. Install two braces (16) on frame (5) with two screws (4) and new locknuts (3).
4. Install upper splash guard braces (16) on upper splash guard (7) with two screws (12) and new locknuts (6).

**d. Lower Splash Guard Installation**

Place lower splash guard (10) in retaining strip (9) and install on upper splash guard (7) with five screws (11) and new locknuts (8).

12-5. CARGO BODY UPPER AND LOWER REAR SPLASH GUARD REPLACEMENT (M35A2C)  
(Contd)

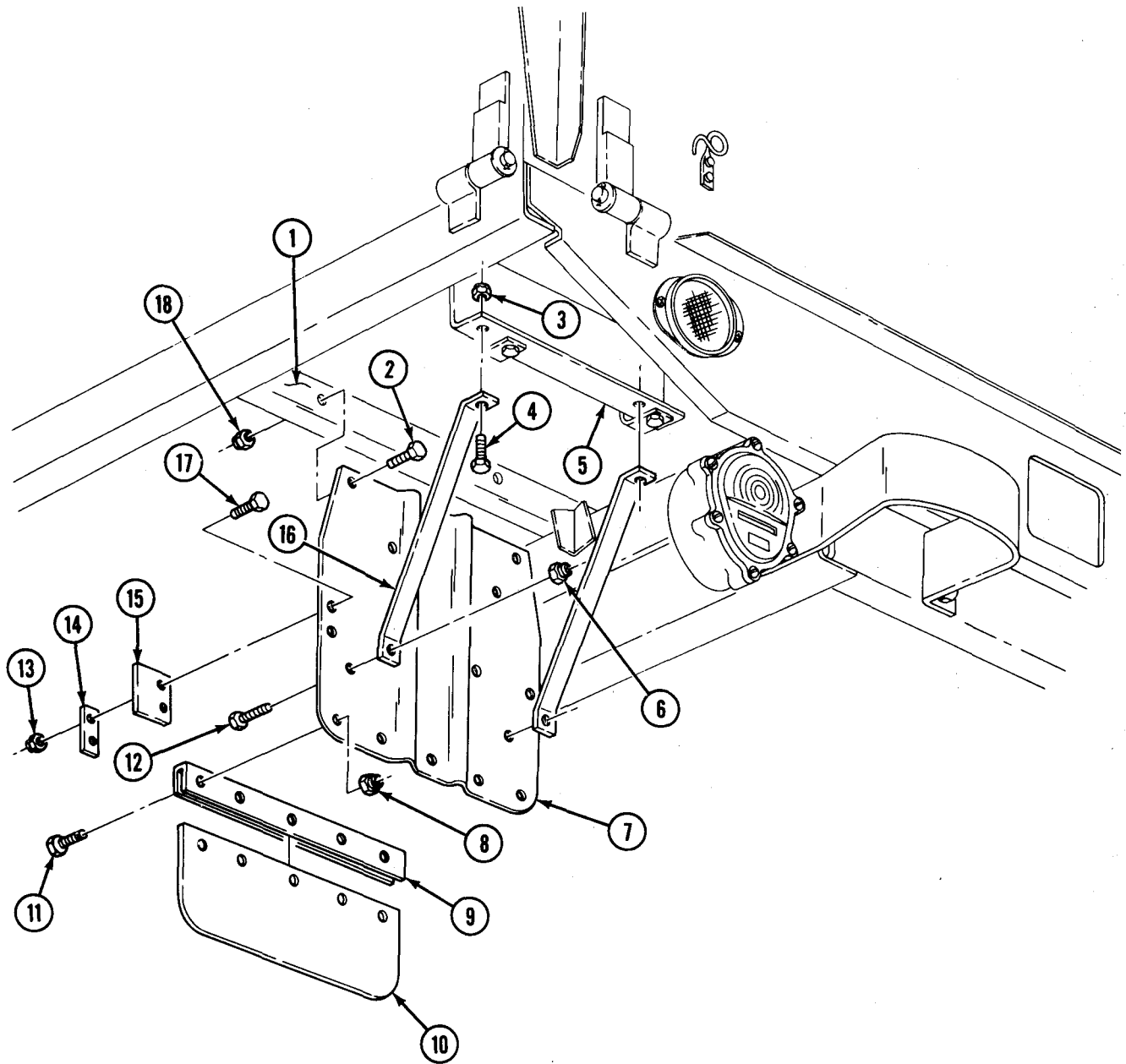

**12-6. FRONT SPLASH GUARD REPLACEMENT (M35A2C, M36A2)**

This task covers:

**a. Removal**

**b. Installation**

INITIAL SETUP:

APPLICABLE MODELS

M35A2C, M36A2

MATERIALS/PARTS

Ten locknuts

REFERENCES (TM)

TM 9-2320-361-10

TM 9-2320-361-20P

EQUIPMENT CONDITION

Parking brake set (TM 9-2320-361-10).

**NOTE**

Left and right front splash guards are removed the same. This procedure covers the left front splash guard.

**a. Removal**

1. Remove two locknuts (13) and screws (8) from splash guard braces (6) and front splash guard (14). Discard locknuts (13).
2. Remove two locknuts (4), screws (5), and splash guard braces (6) from frame (2). Discard locknuts (4).

**NOTE**

Perform step 3 only if pioneer tool kit is on vehicle.

3. Remove two locknuts (15) and screws (7) from front splash guard (14) and pioneer tool kit bracket (1). Discard locknuts (15).
4. Remove two locknuts (3), screws (16), and splash guard (14) from frame (2). Discard locknuts (3).

**NOTE**

Perform step 5 for M35A2C vehicles.

5. Remove two locknuts (9), screws (12), plate (10), and bumper (11) from front splash guard (14). Discard locknuts (9).

**b. Installation**

**NOTE**

Perform step 1 for M35A2C vehicles.

1. Install bumper (11) and plate (10) on front splash guard (14) with two screws (12) and new locknuts (9).
2. Install front splash guard (14) on frame (2) with two screws (16) and new locknuts (3).

**NOTE**

Perform step 3 only if pioneer tool kit is installed on vehicle.

3. Install front splash guard (14) on pioneer tool kit bracket (1) with two screws (7) and new locknuts (15).
4. Install two splash guard braces (6) on frame (2) with two screws (5) and new locknuts (4).
5. Install two splash guard braces (6) on front splash guard (14) with screws (8) and new locknut (13).

12-6. FRONT SPLASH GUARD REPLACEMENT (M35A2C, M36A2) (Contd)

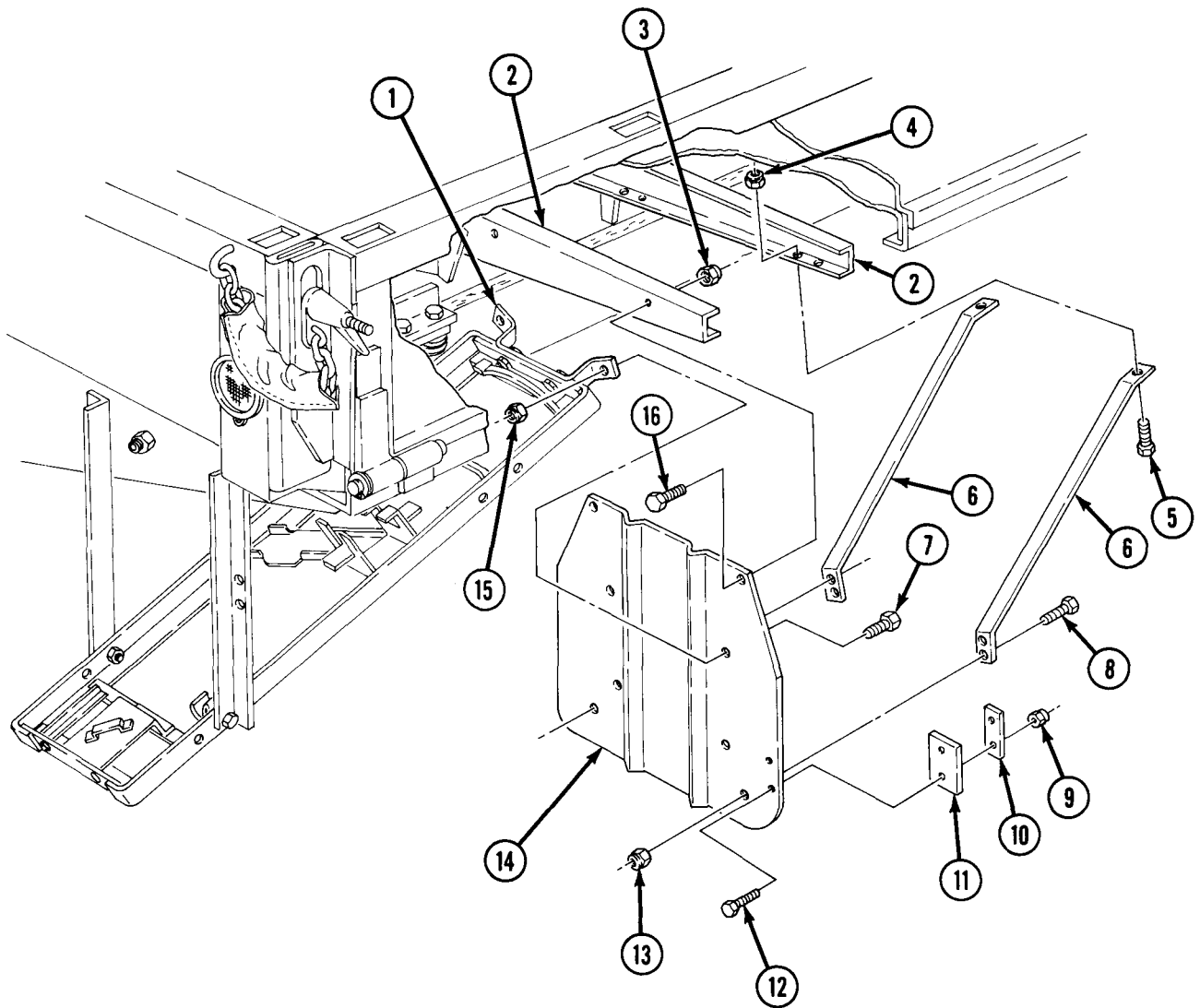



## 12-7. CARGO BODY FRONT RACK MAINTENANCE (M35A2C)

This task covers:

- a. Removal
- b. Inspection

c. Installation

INITIAL SETUP:

APPLICABLE MODELS

M35A2C

REFERENCES (TM)

TM 9-2320-361-10

TM 9-2320-361-20P

EQUIPMENT CONDITION

- Parking brake set (TM 9-2320-361-10).
- Cargo body front rack removed (TM 9-2320-361-10).

### a. Removal

1. Remove twenty nuts (2), screws (5), two stake bow retainers (1), and two body post stakes (11) from front rack slats (10).
2. Remove two wood fillers (4) from body post stakes (11).
3. Remove twelve nuts (9), screws (8), and end stakes (3) from six rack slats (10).
4. Remove chain hook (7) and locking pin assembly (6) from second rack slat (10).

### b. Inspection

1. Inspect stake bow retainers (1), body post stakes (11), and end stakes (3) for cracks, bends, and excessive rust. Replace stake bow retainers (1), body post stakes (11), and end stakes (3) if cracked, bent, or excessively rusted.
2. Inspect all cargo body rack slats (10). Replace if excessively splintered, warped, or rotted.

### c. Installation

**NOTE**

Position body post stakes with double thickness of metal towards outside of body.

1. Install two wood fillers (4) in body post stakes (11).

**NOTE**

Do not tighten nuts until all screws are installed.

2. Install two body post stakes (11) and stake bow retainers (1) on rack slats (10) with twenty screws (5) and nuts (2).
3. Install stakes (3) on ends of rack slats (10) with twelve screws (8) and nuts (9). Do not tighten
4. Install chain hook (7) and locking pin assembly (6) on second rack slat (10).
5. Tighten all nuts (2) and (9).

12-7. CARGO BODY FRONT RACK MAINTENANCE (M35A2C) (Contd)

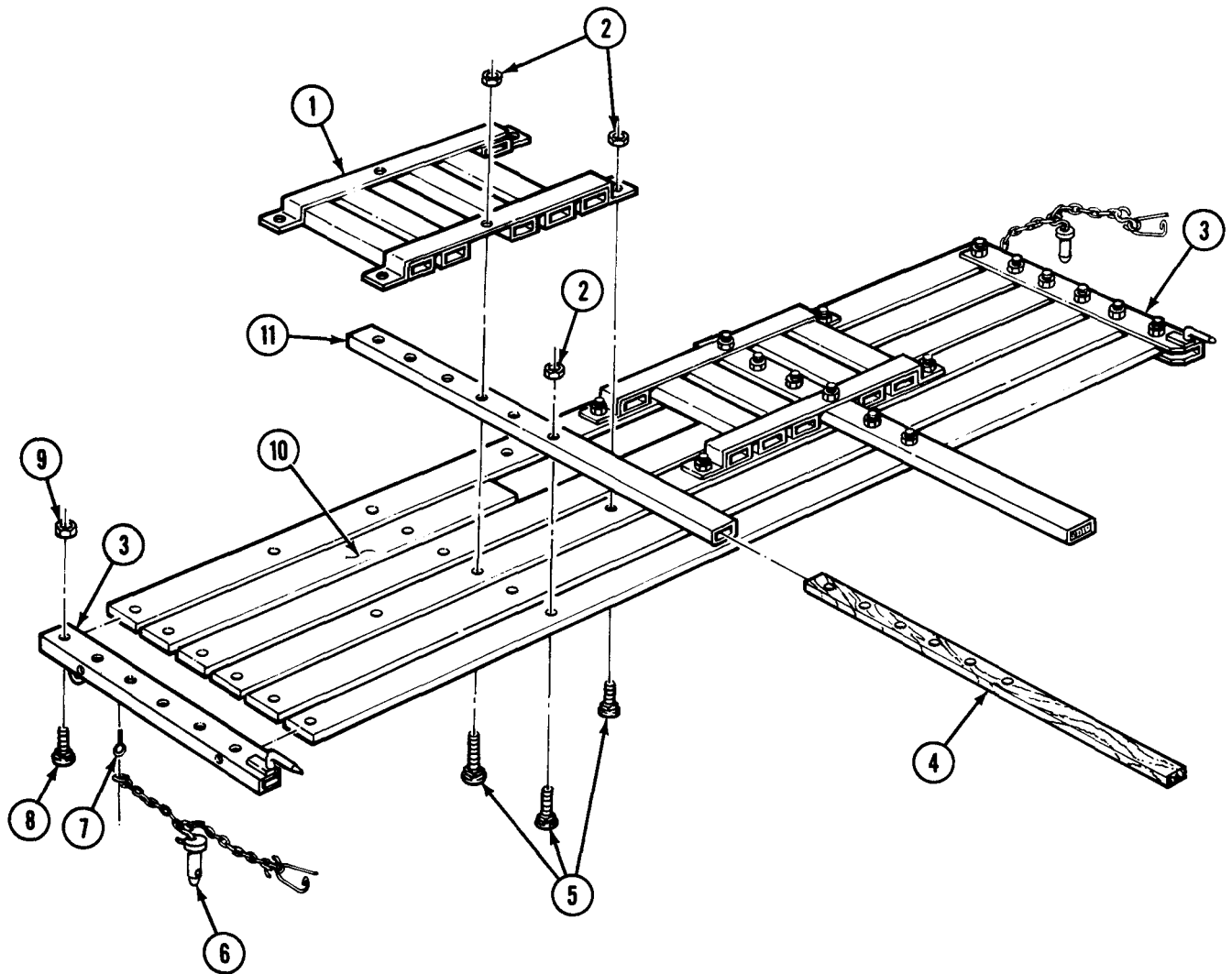

FOLLOW-ON TASK: Install cargo body front rack (TM 9-2320-361-10).

## 12-8. CARGO BODY DROPSIDE REPLACEMENT (M35A2C)

This task covers:

**a. Removal**

**b. Installation**

**INITIAL SETUP:**

APPLICABLE MODELS

M35A2C

MATERIALS/PARTS

Ten cotter pins

PERSONNEL REQUIRED

Two

REFERENCES (TM)

TM 9-2320-361-10

TM 9-2320-361-20P

EQUIPMENT CONDITION

- Parking brake set (TM 9-2320-361-10).
- Rack and troop seat removed (TM 9-2320-361-10).
- Tailgate lowered (TM 9-2320-361-10).
- Stabilizer removed (TM 9-2320-361-10).
- Cargo body dropsides lowered (TM 9-2320-361-10).
- Bow and tarp removed (if installed) (TM 9-2320-361-10).

GENERAL SAFETY INSTRUCTIONS

- All personnel must stand clear during lifting operations.
- All personnel must stand clear during removal of cargo body drop side.

**a. Removal**

1. With cargo body dropside (7) in lowered position, attach sling (1) to lifting device (2) and cargo body dropside (6).
2. Raise lifting device (2) until cargo body dropside (7) is raised to vertical position.

**WARNING**

- All personnel must stand clear during lifting operations. A swinging or shifting load may result in injury to personnel.
- All personnel must stand clear during removal of cargo body dropside, Cargo body dropside will swing free when pins are removed and injury to personnel may result.

3. Remove ten cotter pins (3), washers (4), and five pins (5) from hinges (6). Discard cotter pins (3).
4. Lower dropside (7) to ground and remove lifting device (2) and chain sling (1) from dropside (7).

**b. Installation**

1. Attach chain sling (1) to cargo dropside (7) and attach lifting device (2) to chain sling (1).

**NOTE**

Assistant will help with steps 2 and 3.

2. Raise cargo body dropside (7) and position to hinges (6).
3. Install cargo body dropside (7) on hinges (6) with five pins (5), ten washers (4), and ten new cotter pins (3).
4. Lower cargo body dropside (7) to the lowered position and remove lifting device (2) and chain sling (1).

## 12-8. CARGO BODY DROPSIDE REPLACEMENT [M35A2C] (Contd)

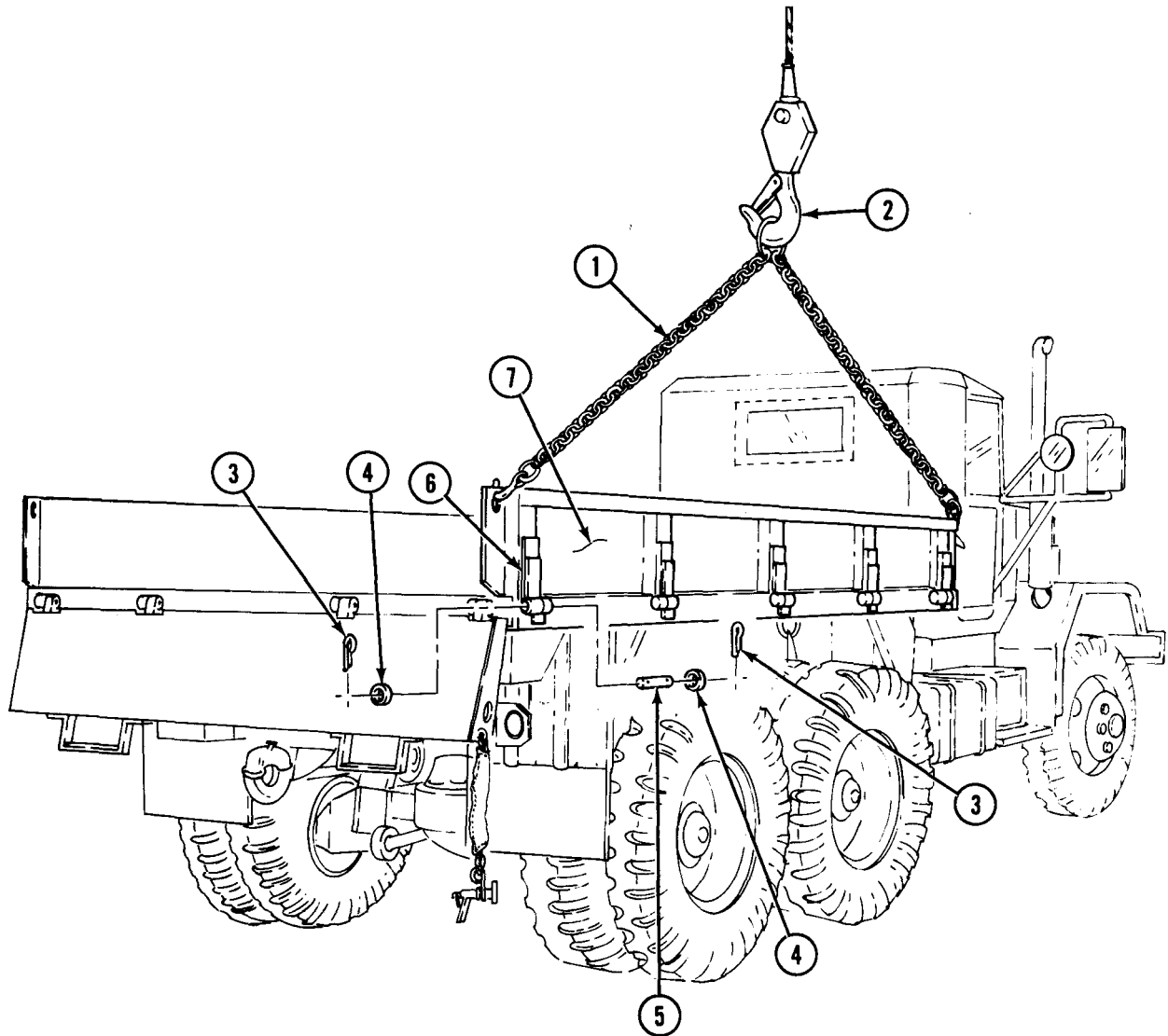

- FOLLOW-ON TASKS:
- Raise cargo body dropsides (TM 9-2320-361-10).
  - Raise tailgate (TM 9-2320-361-10).
  - Install rack and troop seat (TM 9-2320-361-10).
  - Install stabilizer (TM 9-2320-361-10).
  - Install bow and tarp (if removed) (TM 9-2320-361-10).

## 12-9. CARGO BODY FRONT RACK MAINTENANCE (M36A2)

This task covers:

- |  |                    |
|--|--------------------|
| <p>a. Disassembly</p> <p>b. Inspection</p> | <p>c. Assembly</p> |
|--|--------------------|

**INITIAL SETUP:**

APPLICABLE MODELS

M36A2

REFERENCES (TM)

TM 9-2320-361-10  
 TM 9-2320-361-20P

EQUIPMENT CONDITION

- Parking brake set (TM 9-2320-361-10).
- Cargo body front rack removed (TM 9-2320-361-10).

**a. Disassembly**

1. Remove two nuts (1), screws (8), and handles (9) from cargo front rack end channels (7).
2. Remove twelve nuts (3), screws (5), and two posts (2) from cargo body front rack slats (6).
3. Remove two wood fillers (4) from two posts (2).
4. Remove ten nuts (1), screws (8), and two end channels (7) from cargo body front rack slats (6).

**b. Inspection**

1. Inspect two posts (2) and end channels (7) for cracks, bends, and excessive rust. Replace posts (2) or end channels (7) if cracked, bent, or excessively rusted.
2. Inspect cargo body front rack wood slats (6) for splinters, warps, or excessive rotting. Replace front rack wood slats (6) if splintered, warped, or excessively rotted.

**c. Assembly**

**NOTE**

Do not tighten nuts until all screws are installed.

1. Install two end channels (7) on front rack slats (6) with ten screws (8) and nuts (1).
2. Insert two wood fillers (4) in posts (2).
3. Install two posts (2) on front rack slats (6) with twelve screws (5) and nuts (3). Do not tighten nuts (3).
4. Install two handles (9) on cargo body front rack end channels (7) with two screws (8) and nuts (1).
5. Tighten ten nuts (1) and twelve nuts (3).

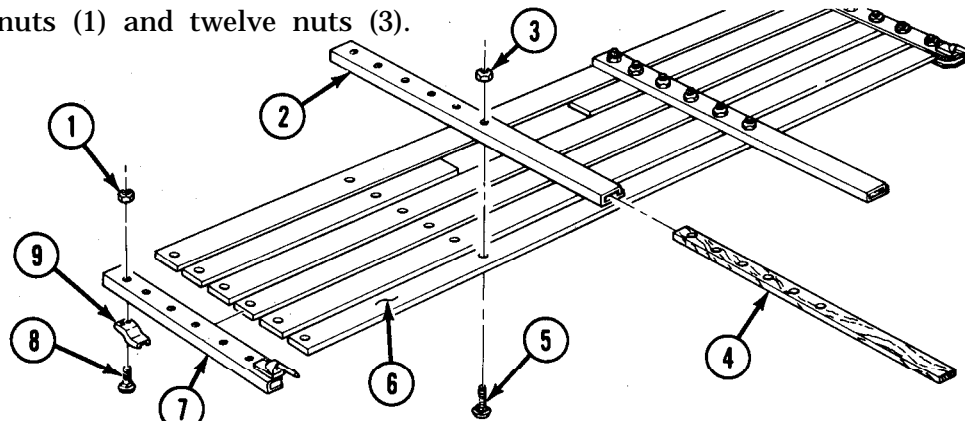

FOLLOW-ON TASK: Install cargo body front rack (TM 9-2320-361-10).

## 12-10. CARGO BODIES TAILGATE MAINTENANCE

This task covers:

### a. Cleaning and Inspection

### b. Repair

#### INITIAL SETUP:

##### APPLICABLE MODELS

M35A2, M35A2C, M36A2

##### REFERENCES (TM)

FM 43-2  
TB 43-0209  
TC 9-510  
TM 9-237

##### REFERENCES (TM) (Contd)

TM 9-2320-361-20  
TM 9-2320-361-20P  
TM 43-0139

##### EQUIPMENT CONDITION

Cargo body tailgate removed (paras. 12-3 and 12-4).

### a. Cleaning and Inspection

1. Clean cargo body tailgate (1) (TB 43-0209 and TM 43-0139).
2. Inspect cargo body tailgate (1) for structural damage or rust. Replace if damage or rust is severe and exceeds available repair procedures.

### b. Repair

1. Remove and install lashing hooks and/or data plate(s) in area(s) to be repaired or painted (paras. 12-3 and 12-4).
2. Remove paint and/or rust from area(s) to be welded or repaired (TM 9-237).

#### NOTE

Refer to TM 43-0139 and TB 43-0209 for body repainting and camouflaging.

3. Repair cargo body tailgate (1) (TM 9-237 and TC 9-510). If welding is necessary, notify your supervisor.

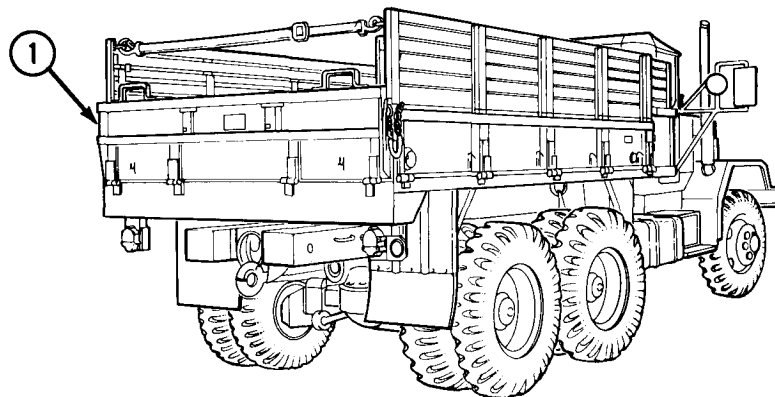

FOLLOW-ON TASK: Install cargo body tailgate (paras. 12-3 and 12-4).

Section II. DUMP BODY MAINTENANCE

**12-11. DUMP BODY MAINTENANCE INDEX**

PARA. NO.	TITLE	PAGE NO.
12-12.	Dump Body Tailgate Replacement	12-16
12-13	Dump Body Tailgate Repair	12-18
12-14.	Hydraulic Hoist Pump Propeller Shaft Maintenance	12-19
12-15.	Dump Body Front Splash Guard Replacement	12-20
12-16.	Dump Body Toolbox Maintenance	12-22
12-17.	Dump Body Rear Splash Guard Replacement	12-24
12-18.	Dump Body Spare Tire Carrier Replacement.	12-26

**12-12. DUMP BODY TAILGATE REPLACEMENT**

This task covers:

**a. Removal**

**b. Installation**

**INITIAL SETUP:**

APPLICABLE MODELS

M342A2

MATERIALS/PARTS

Four locknuts

PERSONNEL REQUIRED

Two

REFERENCES (TM)

TM 9-2320-361-10

TM 9-2320-361-20P

EQUIPMENT CONDITION

- Parking brake set (TM 9-2320-361-10).
- Reflectors removed (para. 11-44).
- Tailgate control levers disengaged (TM 9-2320-361-10).

GENERAL SAFETY INSTRUCTIONS

Tailgate is heavy. Be prepared to support tailgate as soon as retaining pins are removed.

## 12-12. DUMP BODY TAILGATE REPLACEMENT (Contd)

### a. Removal

1. Disconnect two safety chains (6) from dump body (7).

### WARNING

Tailgate is heavy. Ensure tailgate is supported prior to removing pins. Failure to do so may cause injury to personnel.

### NOTE

Assistant will help with step 2.

2. Remove two retaining pins (1) and tailgate (5) from dump body (7).
3. Remove four locknuts (4), screws (2), and two steps (3) from tailgate (5). Discard locknuts (4).
4. Remove chain (8) from dump body (7).

### b. Installation

1. Install two chains (8) on dump body (7).
2. Install two steps (3) on tailgate (5) with four screws (2) and new locknuts (4).
3. Install tailgate (5) on dump body (7) with two retaining pins (1).
4. Connect two safety chains (6) on dump body (7).

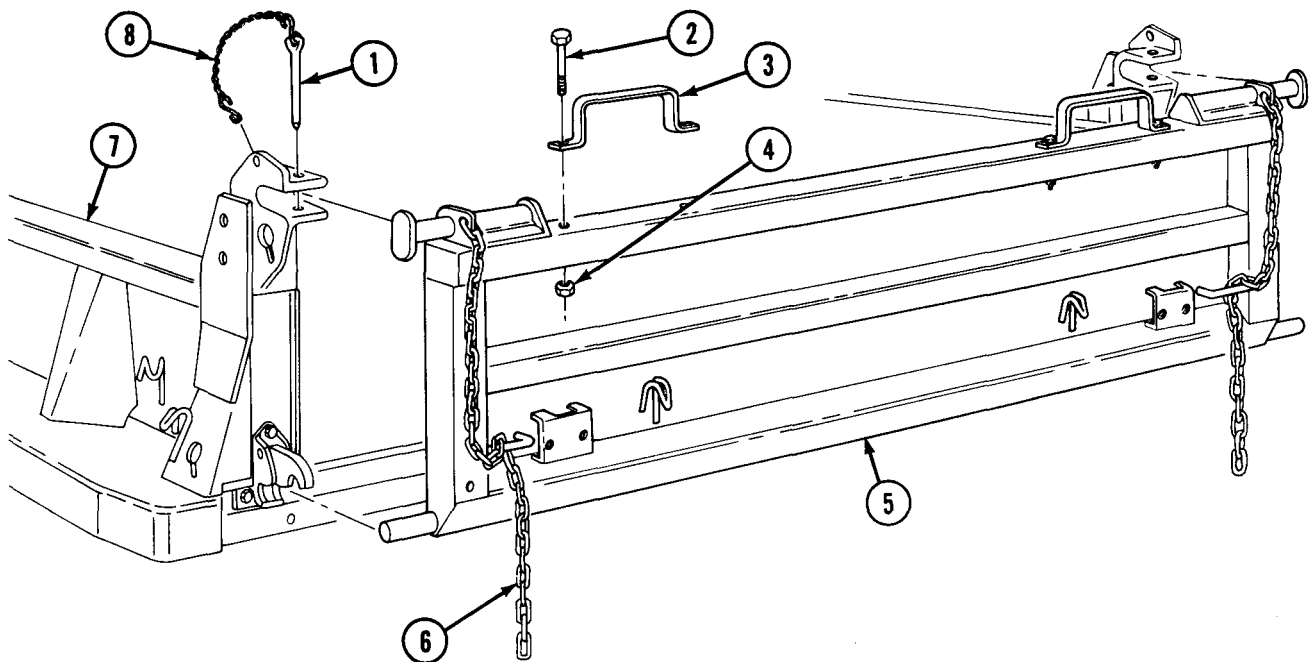

FOLLOW-ON TASKS: • Tailgate control levers engaged (TM 9-2320-361-10).  
• Install reflectors (para. 11-44).



## 12-13. DUMP BODY TAILGATE REPAIR

This task covers:

### a. Cleaning

### b. Inspection and Repair

#### INITIAL SETUP

##### APPLICABLE MODELS

M342A2

##### REFERENCES (TM)

TB 43-0209

TC 9-510

TM 9-237

TM 9-2320-361-10

TM 9-2320-361-20P

##### EQUIPMENT CONDITION

- Parking brake set (TM 9-2320-361-10).
- Dump body tailgate removed (para. 12-12).

### a. Cleaning

Remove paint and/or rust from areas to be welded or repaired (TM 9-237).

### b. Inspection and Repair

1. Inspect tailgate (1) for cracks, dents, and rust. Repair if damaged (TC 9-510 and TM 9-237). If welding is necessary, notify your supervisor.
2. Clean and paint as necessary (TB 43-0209).

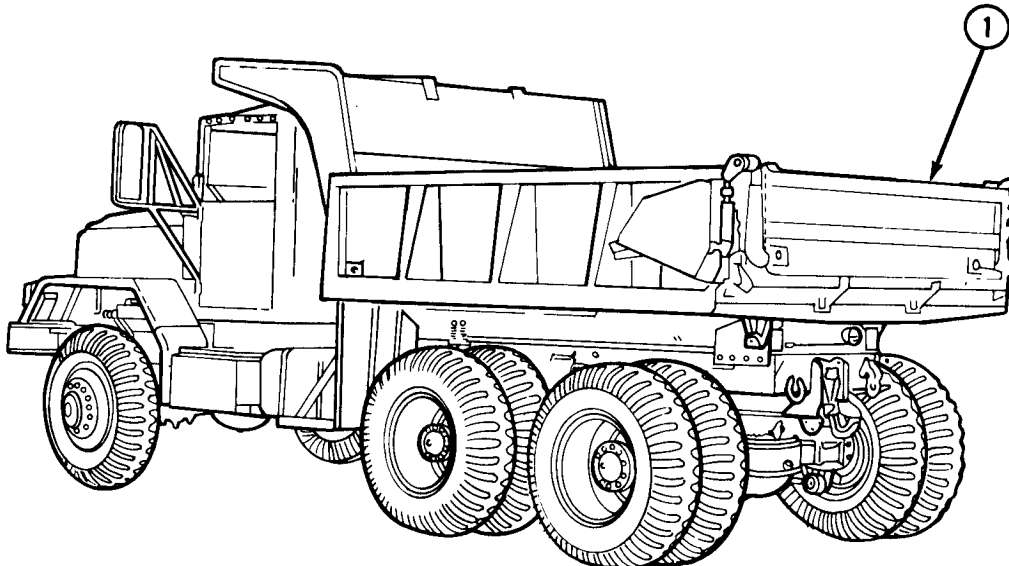

FOLLOW-ON TASK: Install dump body tailgate (para. 12-12).

## 12-14. HYDRAULIC HOIST PUMP PROPELLER SHAFT MAINTENANCE

This task covers:

- a. Removal
- b. Inspection

c. Installation

INITIAL SETUP:

### APPLICABLE MODELS

M342A2

### MATERIALS/PARTS

Two woodruff keys  
Safety wire (Appendix C, Item 22)

### REFERENCES (TM)

TM 9-2320-361-10  
TM 9-2320-361-20P

### EQUIPMENT CONDITION

Parking brake set (TM 9-2320-361-10).

### a. Removal

1. Remove safety wires (2) from two setscrews (1) on front yoke (6) and rear yoke (8). Discard wire (2).
2. Loosen setscrew (1) on rear yoke (8) and remove propeller shaft (7), universal joint (3), rear yoke (8), and woodruff key (9) from pump shaft (10). Discard woodruff key (9).
3. Loosen setscrew (1) on front yoke (6) and remove propeller shaft (7), universal joint (3), front yoke (6), and woodruff key (5) from PTO shaft (4). Discard woodruff key (5).

### b. Inspection

Inspect universal joints (3) for looseness or roughness. Replace universal joints (3) if damaged (para. 7-4).

### c. Installation

1. Install new woodruff key (5), front yoke (6), universal joint (3), and propeller shaft (7) on PTO shaft (4). Tighten setscrew (1) on front yoke (6).
2. Install new woodruff key (9), rear yoke (8), universal joint (3), and propeller shaft (7) on pump shaft (10). Tighten setscrew (1) on rear yoke (8).
3. Install new safety wires (2) through two setscrews (1) on rear yoke (8) and front yoke (6).

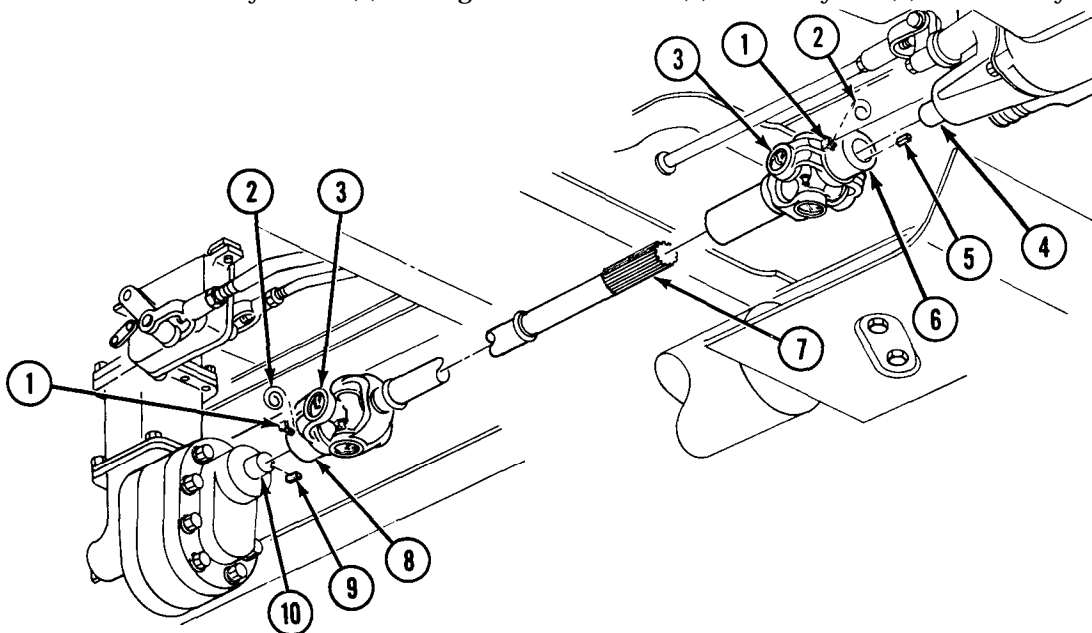

**12-15. DUMP BODY FRONT SPLASH GUARD REPLACEMENT**

**This task covers:**

**a. Removal**

**b. Installation**

**INITIAL SETUP:**

APPLICABLE MODELS

M342A2

MATERIALS/PARTS

Twelve locknuts

REFERENCES (TM)

TM 9-2320-361-10

TM 9-2320-361-20P

EQUIPMENT CONDITION

Parking brake set (TM 9-2320-361-10).

**a. Removal**

1. Remove two locknuts (1), screws (7), and brace (8) from front splash guard (6), support (5), and frame (2). Discard locknuts (1).

**NOTE**

If replacing right side front splash guard, remove braces from fuel tank bracket.

2. Remove four locknuts (11), screws (10), and two braces (9) from front splash guard (6) and air reservoir bracket (12). Discard locknuts (11).
3. Remove three locknuts (1), screws (7), and front splash guard (6) from support (5). Discard locknuts (1).
4. Remove three locknuts (3), screws (4), and support (5) from frame (2). Discard locknuts (3).

**b. Installation**

1. Install support (5) on frame (2) with three screws (4) and new locknuts (3).
2. Install front splash guard (6) on support (5) with three screws (7) and new locknuts (1).

**NOTE**

If replacing right side front splash guard, braces are installed on fuel tank bracket.

3. Install two braces (9) on front splash guard (6) and air reservoir bracket (12) with four screws (10) and new locknuts (11).
4. Install brace (8) on front splash guard (6) and frame (2) with two screws (7) and new locknuts (1).

12-15. DUMP BODY FRONT SPLASH GUARD REPLACEMENT (Contd)

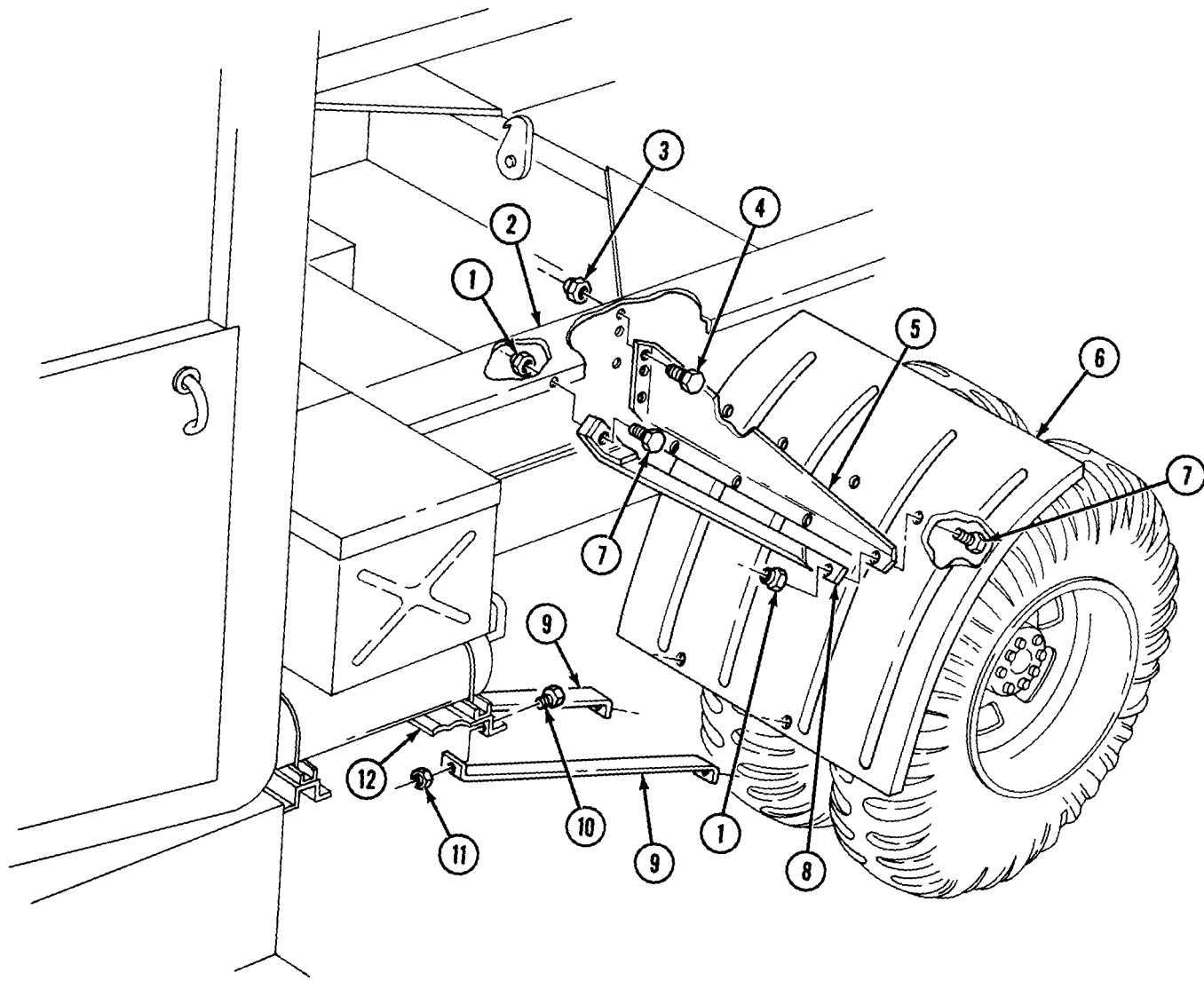

**12-16. DUMP BODY TOOLBOX MAINTENANCE**

This task covers:

- a. Removal
- b. Disassembly

- c. Assembly
- d. Installation

INITIAL SETUP:

APPLICABLE MODELS

M342A2

MATERIALS/PARTS

Two screw-assembled lockwashers  
Ten locknuts

REFERENCES (TM)

TM 9-2320-361-10  
TM 9-2320-361-20P

EQUIPMENT CONDITION

Parking brake set (TM 9-2320-361-10).

**a. Removal**

Remove four locknuts (3), screws (6), two screw-assembled lockwashers (2), spacers (5), and toolbox (1) from spare tire carrier (4). Discard screw-assembled lockwashers (2) and locknuts (3).

**b. Disassembly**

1. Remove four locknuts (12), screws (8), and cover (7) from toolbox (1). Discard locknuts (12).
2. Remove two locknuts (9), screws (11), and bracket (10) from toolbox (1). Discard locknuts (9).
3. Remove two clips (13) from toolbox (1).

**c. Assembly**

1. Install two clips (13) on toolbox (1).
2. Install bracket (10) on toolbox (1) with two screws (11) and new locknuts (9).
3. Install cover (7) on toolbox (1) with four screws (8) and new locknuts (12).

**d. Installation**

Install two spacers (5) and toolbox (1) on spare tire carrier (4) with two new screw-assembled lockwashers (2), four screws (6), and new locknuts (3).

12-16. DUMP BODY TOOLBOX MAINTENANCE (Contd)

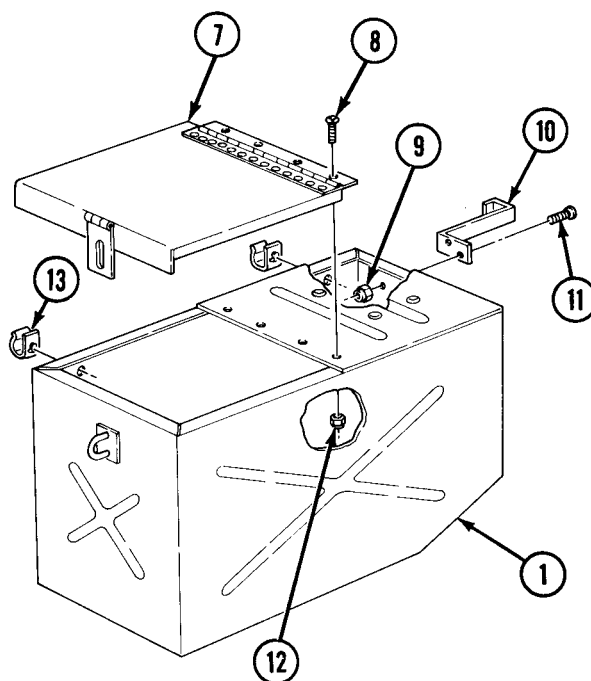
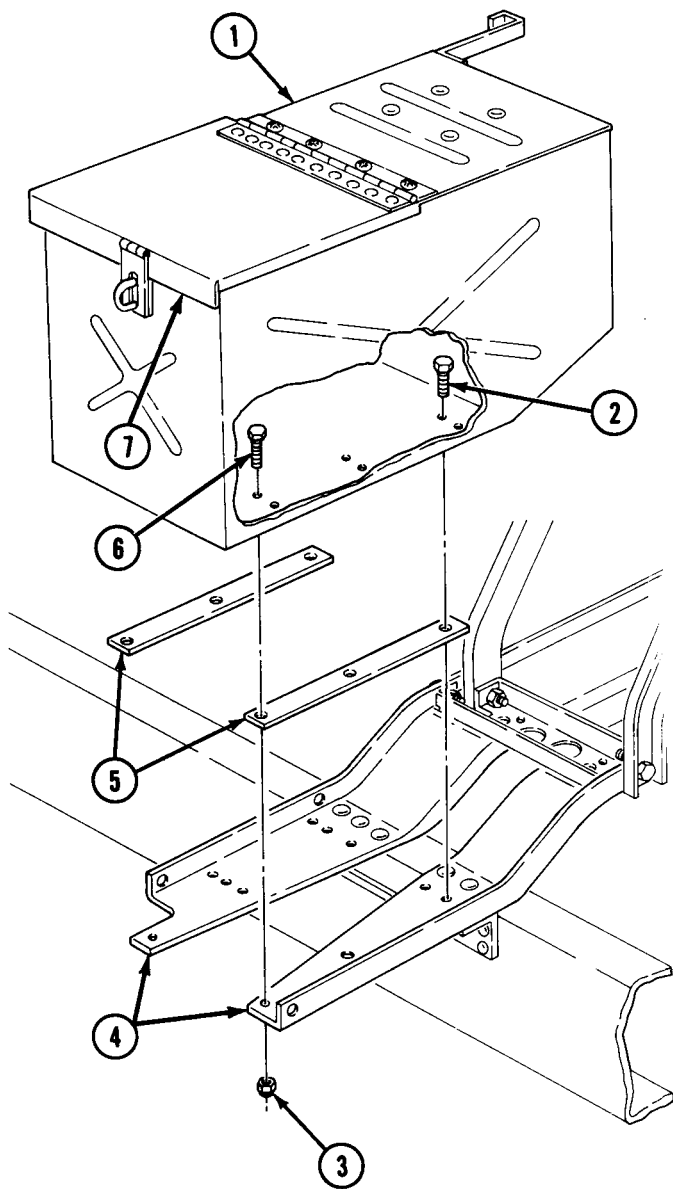

**12-17. DUMP BODY REAR SPLASH GUARD REPLACEMENT**

This task covers:

**a. Removal**

**b. Installation**

INITIAL SETUP:

APPLICABLE MODELS

M342A2

MATERIALS/PARTS

Twelve locknuts

REFERENCES (TM)

TM 9-2320-361-10

TM 9-2320-361-20P

EQUIPMENT CONDITION

Parking brake set (TM 9-2320-361-10).

**a. Removal**

1. Remove five locknuts (4), screws (8), splash guard (7), and retaining strip (6) from guard (5). Remove retaining strip (6) from splash guard (7). Discard locknuts (4).
2. Remove five locknuts (3), screws (9), and guard (5) from mounting bracket (2). Discard locknuts (3).
3. Remove two locknuts (1), screws (10), and mounting bracket (2) from frame (11). Discard locknuts (1).

**b. Installation**

1. Install mounting bracket (2) on frame (11) with two screws (10) and new locknuts (1).
2. Install guard (5) on mounting bracket (2) with five screws (9) and new locknuts (3).
3. Install retaining strip (6) and splash guard (7) on guard (5) with five screws (8) and new locknuts (4).

**12-17. DUMP BODY REAR SPLASH GUARD REPLACEMENT (Contd)**

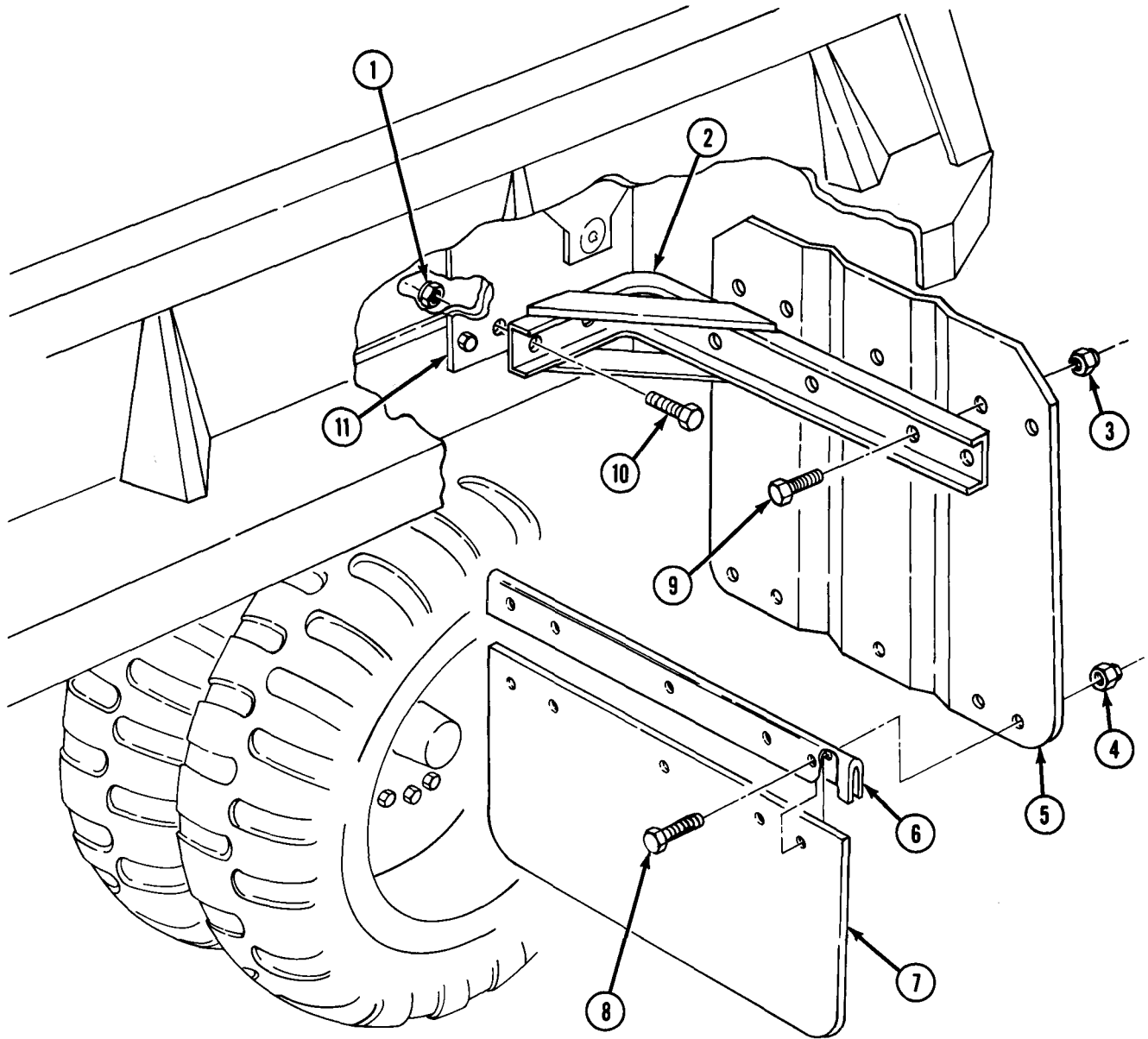



**12-18. DUMP BODY SPARE TIRE CARRIER REPLACEMENT**

This task covers:

**a. Removal**

**b. Installation**

**INITIAL SETUP:**

APPLICABLE MODELS

M342A2

REFERENCES (TM)

TM 9-2320-361-10

TM 9-2320-361-20P

MATERIALS/PARTS

Two cotter pins

Thirty-seven locknuts

EQUIPMENT CONDITION

- Parking brake set (TM 9-2320-361-10).
- Spare tire removed (TM 9-2320-361-10).
- Dump bed raised (TM 9-2320-361-10).
- Rear cab mount removed (para. 11-23).
- Toolbox removed (para. 12-16).

**a. Removal**

1. Remove four locknuts (7), screws (8), and bar assemblies (1) from spare tire carrier support member (9) and cab support (10). Discard locknuts (7).
2. Remove eight locknuts (4), screws (2), and two spacers (3) from bar assemblies (1). Discard locknuts (4).
3. Remove two cotter pins (11) from hook bolts (6). Discard cotter pins (11).
4. Remove two sleeve nuts (5) from hook bolts (6) and bar assemblies (1).

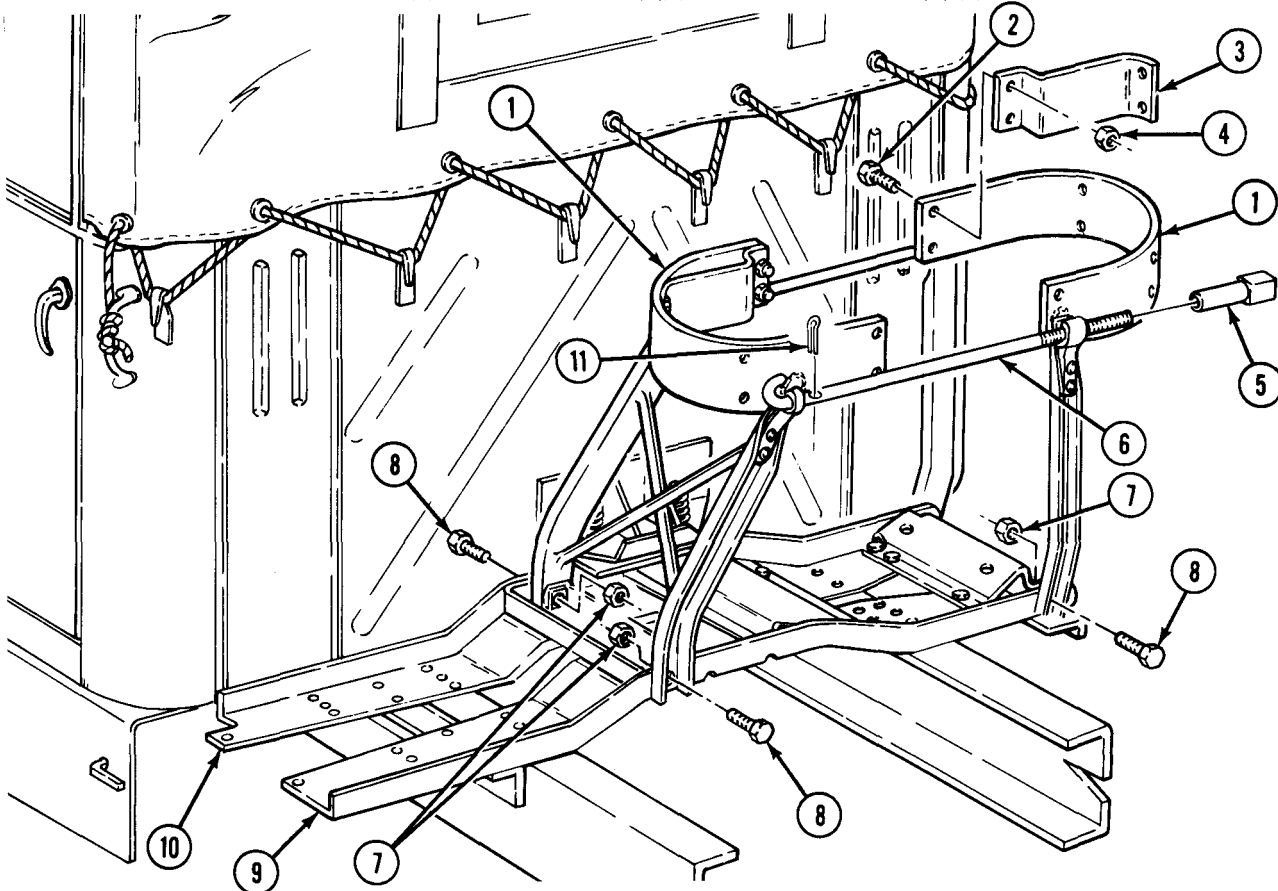

### 12-18. DUMP BODY SPARE TIRE CARRIER REPLACEMENT (Contd)

5. Remove eight locknuts (26), screws (27), support member (9), and cab support (10) from frame (25). Discard locknuts (26).
  6. Remove locknut (18) and screw (17) from cab support (10), support member (9), and support (20). Discard locknut (18).
  7. Remove five locknuts (19), screws (22), support (20), and bracket (21) from support member (9) and cab support (10). Discard locknuts (19).
  8. Remove four locknuts (23), screws (16), and support (15) from support member (9) and cab support (10). Discard locknuts (23).
  9. Remove four locknuts (24), screws (12), and retaining brace (28) from support member (9) and cab support (10). Discard locknuts (24).
  10. Remove three locknuts (29), screws (13), and bracket (14) from cab support (10). Discard locknuts (29).
1. Install bracket (14) on cab support (10) with three screws (13) and new locknuts (29).
  2. Install retaining brace (28) on cab support (10) and support member (9) with four screws (12) and new locknuts (24).
  3. Install support (20) on support member (9) and cab support (10) with screw (17) and new locknut (18).
  4. Install bracket (21) and support (20) on support member (9) and cab support (10) with five screws (22) and new locknuts (19).
  5. Install support (15) on support member (9) and cab support (10) with four screws (16) and new locknuts (23).
  6. Install support member (9) and cab support (10) on frame (25) with eight screws (27) and new locknuts (26).

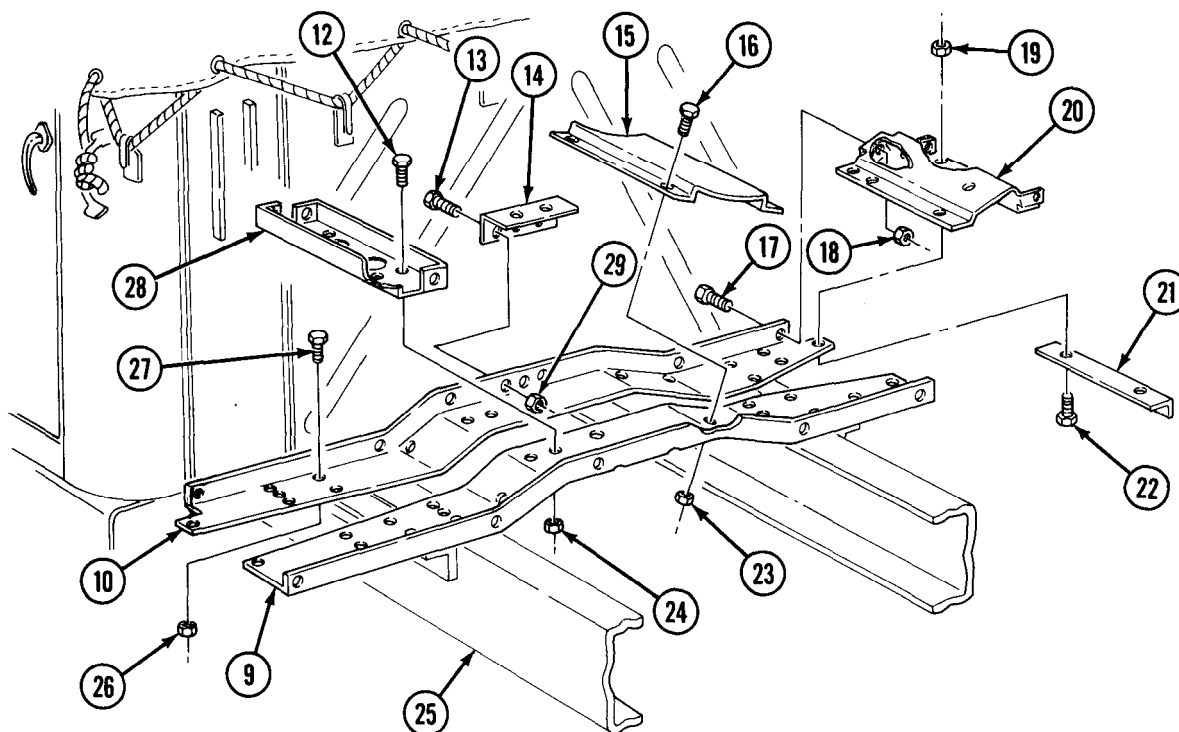

**12-18. DUMP BODY SPARE TIRE CARRIER REPLACEMENT (Contd)**

7. Install two hook bolts (6) on bar assemblies (1) with two sleeve nuts (5).
8. Install two new cotter pins (11) in hook bolts (6).
9. Install two spacers (3) on bar assemblies (1) with eight screws (2) and new locknuts (4).
10. Install two bar assemblies (1) on cab support (10) and support member (9) with four screws (8) and

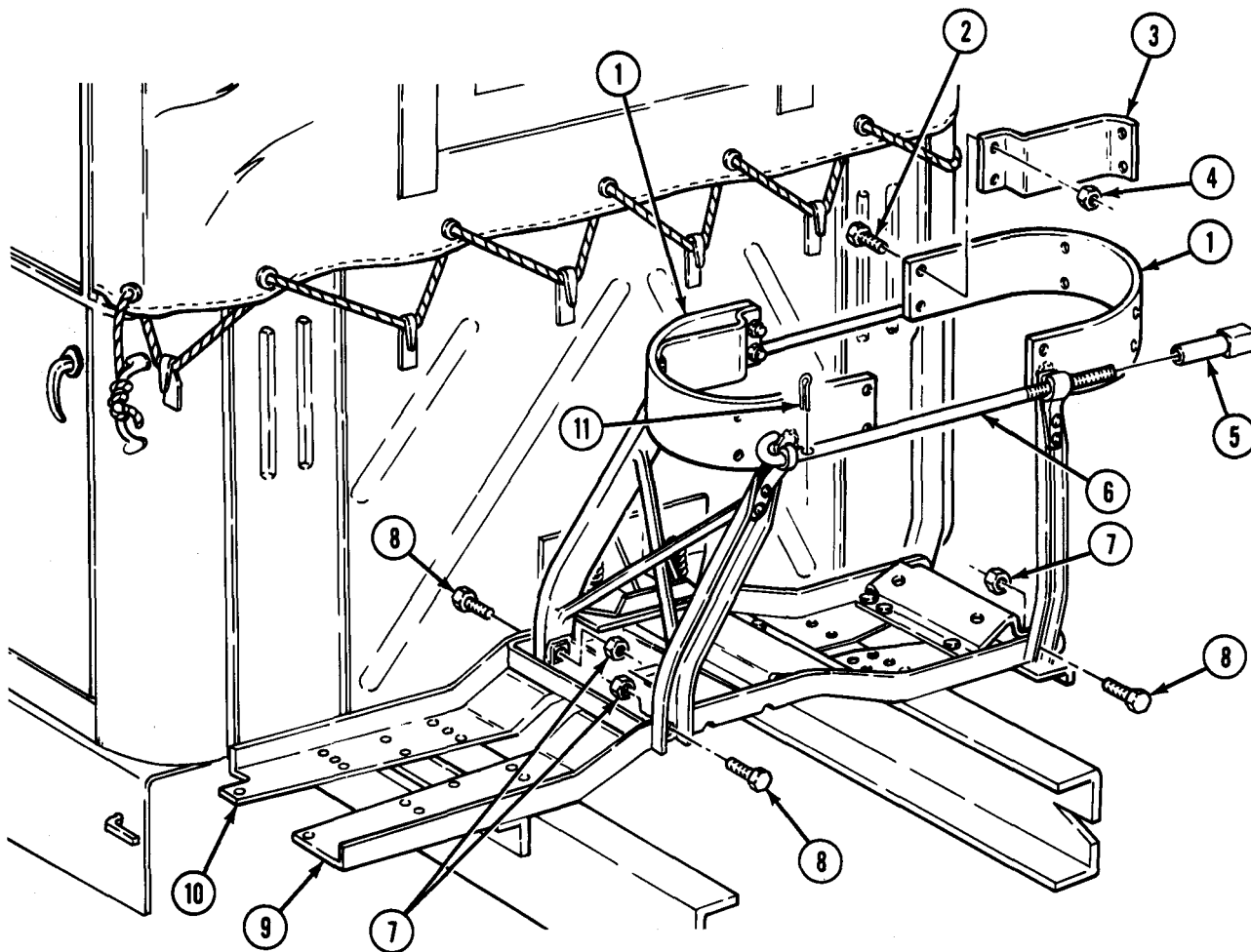

- FOLLOW-ON TASKS:**
- Install spare tire (TM 9-2320-361-10).
  - Lower dump bed (TM 9-2320-361-10).
  - Install cab mount insulators (para. 11-23).
  - Install toolbox (para. 12-16).

## Section III. TANK BODY MAINTENANCE

## 12-19. TANK BODIES MAINTENANCE INDEX

PARA. NO.	TITLE	PAGE NO.
12-20.	Discharge Valve Replacement (M49A2C)	12-30
12-21.	Discharge Valve Control Levers Maintenance (M49A2C)	12-32
12-22.	Front and Rear Fuel Tank Discharge Tubes Replacement (M49A2C)	12-37
12-23.	Fuel Tank Manhole Cover Maintenance (M49A2C)	12-40
12-24.	Fuel Hose and Nozzle Replacement (M49A2C)	12-42
12-25.	Fuel and Water Tank Nozzle Holder Replacement	12-44
12-26.	Overturn Tubes Replacement (M49A2C)	12-45
12-27.	Globe Valve Replacement (M49A2C)	12-46
12-28.	Filter Separator-to-Sump Pipe Replacement (M49A2C)	12-47
12-29.	Static Reel Replacement (M49A2C)	12-48
12-30.	Meter-to-Filter Tube Replacement (M49A2C)	12-49
12-31.	Gallon Meter Replacement (M49A2C)	12-50
12-32.	Delivery Pump Outlet Tube Replacement (M49A2C)	12-51
12-33.	Delivery Pump Inlet Tube Replacement (M49A2C)	12-52
12-34.	Water Pump Manifold Replacement (M50A2, M50A3)	12-53
12-35.	Delivery Pump Replacement	12-54
12-36.	Delivery Pump Draincock Replacement	12-56
12-37.	Meter Outlet Tube Replacement (M49A2C)	12-57
12-38.	Gate Valve Replacement	12-58
12-39.	Delivery Pump Strainer Replacement	12-59
12-40.	Separator Element Test Valve, Gage, and Lines Replacement (M49A2C)	12-60
12-41.	Filter Separator Maintenance (M49A2C)	12-62
12-42.	Water Tank Filler Cover Replacement (M50A2)	12-64
12-43.	Water Tank Filler Cover Replacement (M50A3)	12-65
12-44.	Rear Compartment Door Maintenance	12-66
12-45.	Water Tank Discharge Tube and Valve Replacement (M50A2)	12-68
12-46.	Water Tank Discharge Tube and Valve Replacement (M50A3)	12-70
12-47.	Water Tank Discharge Valve Control Levers Maintenance (M50A2, M50A3)	12-72
12-48.	Water Tank Manhole Cover Replacement (M50A2)	12-78

**12-19. TANK BODIES MAINTENANCE INDEX (Contd)**

PARA. NO.	TITLE	PAGE NO.
12-49.	Water Tank Manhole Cover Maintenance (M50A3)	12-80
12-50.	Delivery Pump Front Propeller Shaft Maintenance (M50A2)	12-81
12-51.	Delivery Pump Front Propeller Shaft Maintenance (M49A2C, M50A3)	12-82
12-52.	Delivery Pump Rear Propeller Shaft Maintenance (M50A2)	12-84
12-53.	Delivery Pump Rear Propeller Shaft Maintenance (M49A2C, M50A3)	12-86
12-54.	Speed Control Cable Maintenance	12-88
12-55.	Tank Bodies Front Splash Guard Replacement	12-90
12-56.	Tank Bodies Upper and Lower Rear Splash Guard Replacement	12-92

**12-20. DISCHARGE VALVE REPLACEMENT (M49A2C)**

This task covers:

**a. Removal**

**b. Installation**

**INITIAL SETUP:**

APPLICABLE MODELS

M49A2C

MATERIALS/PARTS

Two gaskets  
Eleven locknuts

REFERENCES (TM)

TM 9-2320-361-10  
TM 9-2320-361-20P

EQUIPMENT CONDITION

- Parking brake set (TM 9-2320-361-10).
- Fuel tanks drained (TM 9-2320-361-10).

GENERAL SAFETY INSTRUCTIONS

Keep fire extinguisher nearby when working on fuel tank trucks.

**WARNING**

Do not perform this procedure while smoking or within 50 feet of sparks or open flame. Fuel is flammable and can explode easily, causing injury or death to personnel and damage to equipment.

**NOTE**

Both discharge valves are removed the same way.

**a. Removal**

1. Remove two locknuts (10), plates (9), U-bolt (7), and discharge valve cable (8) from discharge lever (5). Discard locknuts (10).
2. Remove locknut (6), screw (4), and lever (5) from discharge valve (16). Discard locknut (6).

## 12-20. DISCHARGE VALVE REPLACEMENT (M49A2C) (Contd)

3. Remove two locknuts (13), screws (15), coupling (14), and gasket (12) from discharge valve (16) and drain tube (11). Discard locknuts (13) and gasket (12).
4. Remove six locknuts (1), discharge valve (16), and gasket (2) from bottom of tank (3). Remove gasket remains from mating surfaces. Discard gasket (2) and locknuts (1).

### b. Installation

1. Install new gasket (2) and discharge valve (16) on bottom of tank (3) with six new locknuts (1).
2. Install new gasket (12) and drain tube (11) on discharge valve (16) with coupling (14), two screws (15), and new locknuts (13).
3. Install lever (5) on discharge valve (16) with screw (4) and new locknut (6).
4. Install cable (8) on lever (5) with U-bolt (7), two plates (9), and two new locknuts (10). Remove slack in cable (8) and tighten nuts (10).

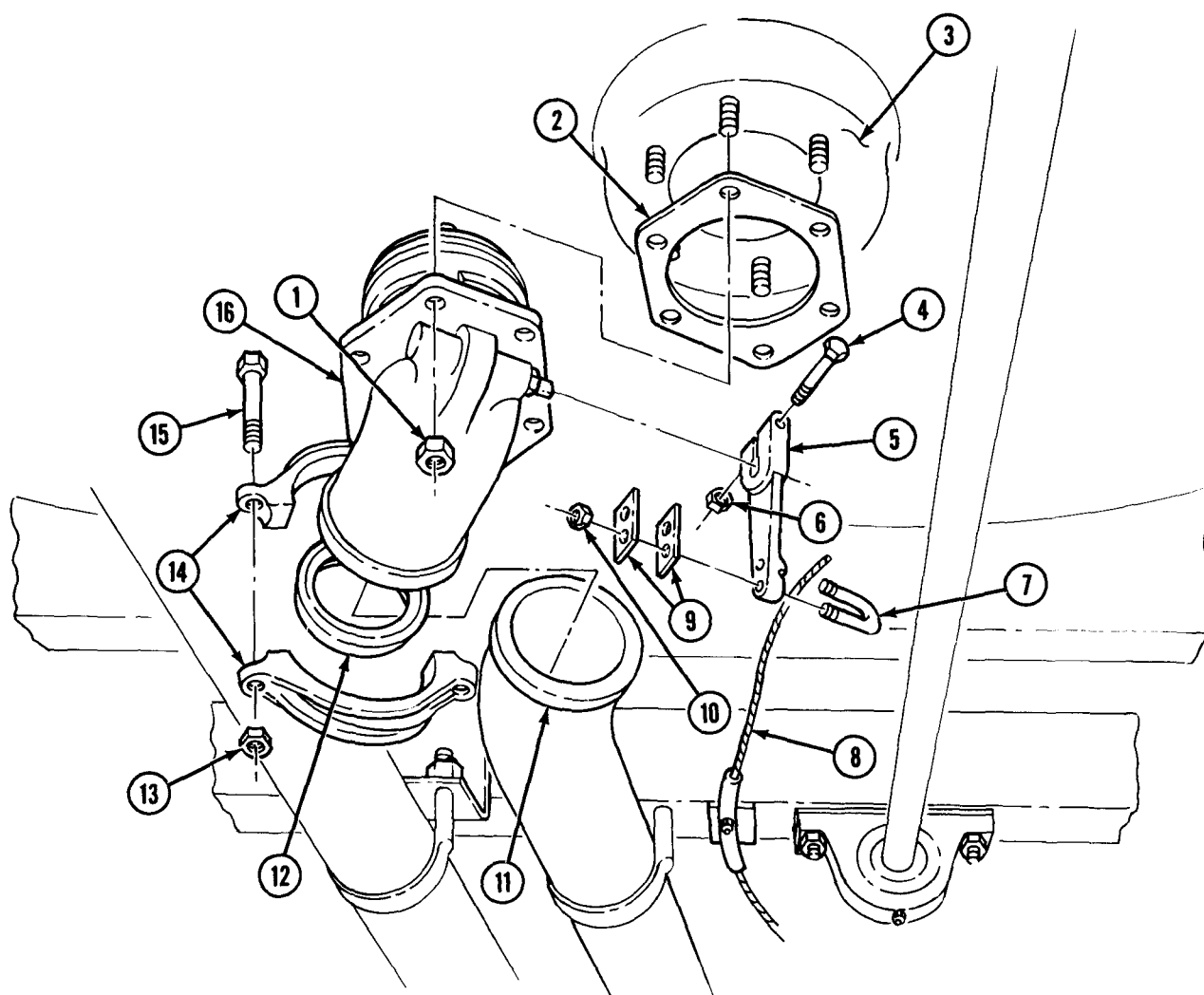

FOLLOW-ON TASK: Fill fuel tanks (TM 9-2320-361-10) and check for leaks.

**12-21. DISCHARGE VALVE CONTROL LEVERS MAINTENANCE (M49A2C)**

This task covers:

- |  |  |
|--|--|
| <ul style="list-style-type: none"> <li>a. Removal</li> <li>b. Disassembly</li> <li>c. Cleaning and Inspection</li> </ul> | <ul style="list-style-type: none"> <li>d. Assembly</li> <li>e. Installation</li> </ul> |
|--|--|

**INITIAL SETUP:**

APPLICABLE MODELS

M49A2C

MATERIALS/PARTS

Six locknuts  
Six lockwashers  
Three cotter pins

REFERENCES (TM)

TM 9-2320-361-10  
TM 9-2320-361-20P

EQUIPMENT CONDITION

Parking brake set (TM 9-2320-361-10).

GENERAL SAFETY INSTRUCTIONS

Keep fire extinguisher nearby when working on fuel tank trucks.

**WARNING**

Do not perform this procedure while smoking or within 50 feet of sparks or open flame. Fuel is flammable and can explode easily, causing injury or death to personnel and damage to equipment.

**a. Removal**

1. Unscrew three coupling nuts (1) from adapters (13) and slide back on tubes (2).
2. Unscrew three adapters (13) from plate (10).
3. Remove three nuts (8) and bolts (3), from levers (9), and pull cables (12) out of bolts (3), plate (10), and adapters (13).
4. Remove six locknuts (7), screws (4), discharge valve control assembly (5), and spacer (6) from compartment (11). Discard locknuts (7).

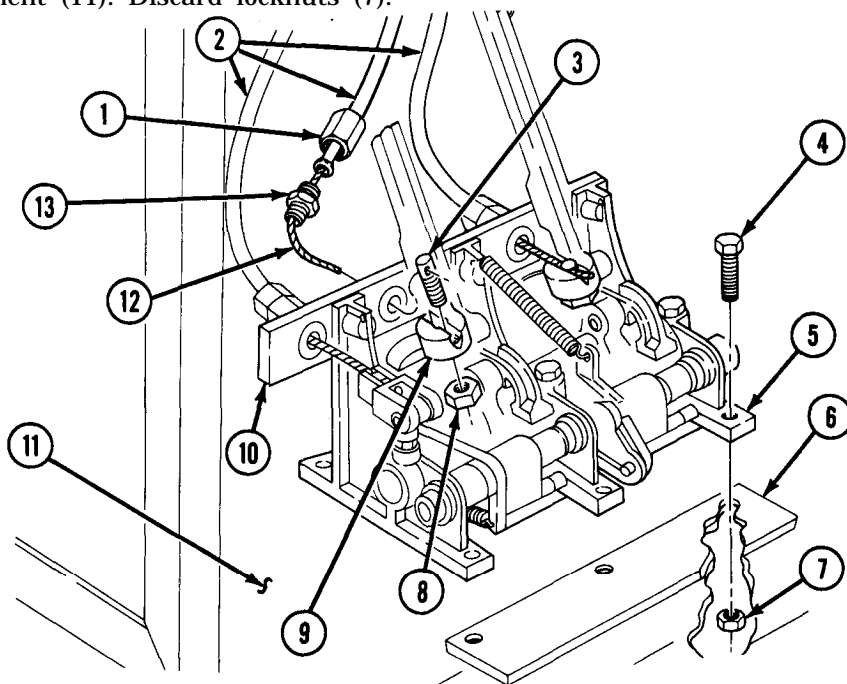

## 12-21. DISCHARGE VALVE CONTROL LEVERS MAINTENANCE (M49A2C) (Contd)

### b. Disassembly

#### CAUTION

Do not strike levers or brackets during lever shaft removal. Striking levers or brackets may result in damage to components.

#### NOTE

All components should be tagged for assembly.

1. Remove springs (44) and (35) from lever arms (27) and (34) and brackets (43) and (36).
2. Remove three screws (19) and lockwashers (20) from brackets (18), (43), and (36). Discard lockwashers (20).
3. Remove lever shaft (21) and levers (17) and (41) from between brackets (18), (43), and (36).
4. Remove cotter pins (28) and (29) and fusible link (30) from lever arm (27) and bracket (43). Discard cotter pins (28) and (29).
5. Remove setscrews (25) and (32) in cams (26) and (33). Remove shaft (22) from bushing (37), lever arm (34), cam (33), bushing (42), lever arm (27), cam (26), and bushing (23). Remove cams (26) and (33).
6. Remove rollers (31) and (24) from bushings (23) and (42).
7. Remove lever arms (27) and (34) from bushings (42) and (37).
8. Remove cotter pin (40) from pin (38) and remove pin (38) and clevis (39) from lever arm (34). Discard cotter pin (40).
9. Remove three screws (15), lockwashers (16), and spacer bar (14) from brackets (18), (43), and (36). Discard lockwashers (16).

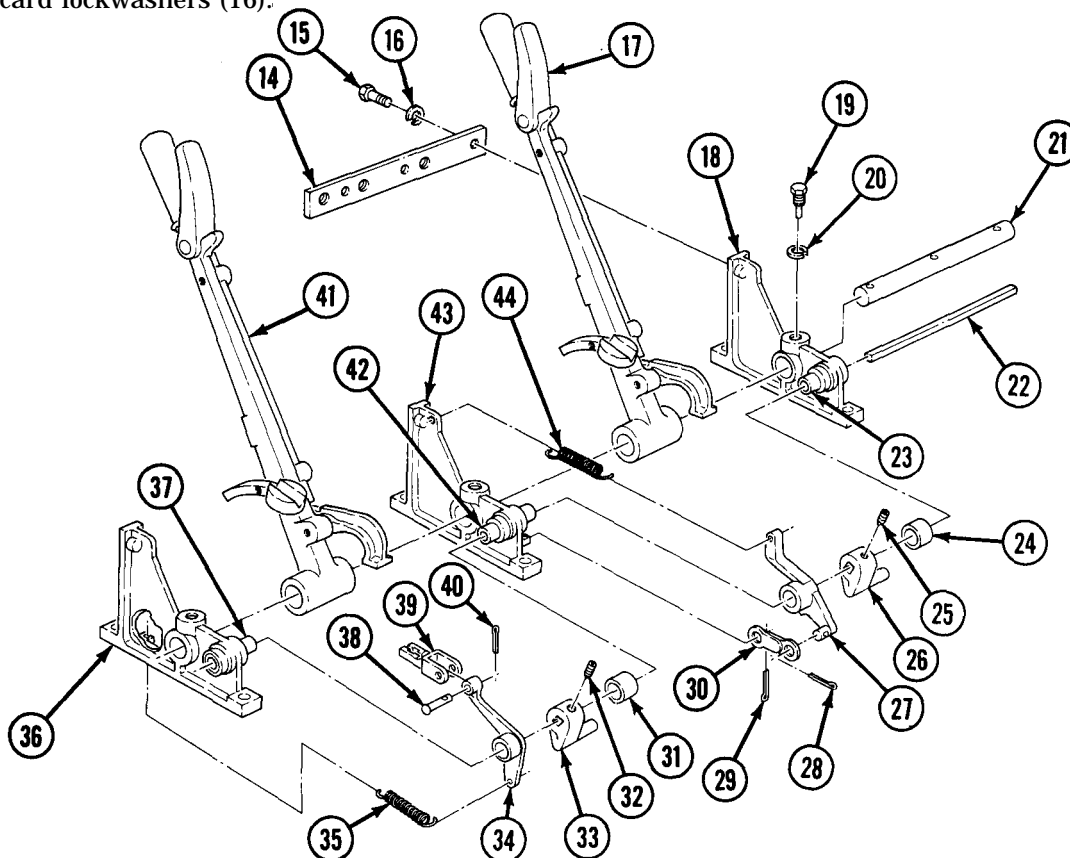



**12-21. DISCHARGE VALVE CONTROL LEVERS MAINTENANCE (M49A2C) (Contd)**

**c. Cleaning and Inspection**

1. Refer to para. 2-10 for general cleaning instructions.
2. Refer to para. 2-10 for general inspection instructions.

*Table 12-1. M49A2C Discharge Valve Control Lever Wear Limits.*

ITEM NO.	ITEM/POINT OF MEASUREMENT	WEAR LIMITS/TOLERANCES	
		INCHES	MILLIMETERS
21	Lever arm (inner diameter at shaft hole)	0.443 - 0.463	11.25 - 11.76
14	Lever arm (inner diameter at shaft hole)	0.430 - 0.454	10.92 - 11.53
4 and 28	Levers (inner diameter at shaft hole)	0.868 - 0.922	22.05 - 23.42
10, 24, and 29	Bushings end exposed (diameter)	0.430 - 0.438	10.92 - 11.13
8	Lever shaft (diameter)	0.860 - 0.885	21.84 - 22.48
11 and 18	Roller (outer diameter)	0.750	19.05
11 and 18	Roller (inner diameter)	0.440 - 0.444	11.18 - 11.28

3. Inspect clevis (26) and pin (25) for cracks or pin hole damage. Replace clevis (26) and pin (25) if cracked or pin hole is damaged.
4. Inspect shaft (9) for twists, cracks, or breakage. Replace shaft, (9) if twisted, cracked, or broken.
5. Inspect lever arms (14) and (21) for wear, cracks, or pin hole damage. Refer to table 12-1, M49A2C Discharge Valve Control Lever Wear Limits, for measurements. Replace lever arms (14) and (21) if not within wear limits.
6. Inspect cams (13) and (19) for cracks or broken tabs. Replace cams (13) and (19) if cracked or tabs are broken.
7. Inspect rollers (11) and (18) for flat spots or wear. Refer to table 12-1, M49A2C Discharge Valve Control Lever Wear Limits, for measurements. Replace rollers (11) and (18) if not within wear limits.
8. Inspect brackets (5), (30), and (23) for cracks or damage. Replace brackets (5), (30), and (23) if cracked or damaged.
9. Inspect installed bushings (10), (24), and (29) for grooves or wear. Refer to table 12-1, M49A2C Discharge Valve Control Lever Wear Limits, for measurements. Replace bushings (10), (24), and (29) if not within wear limits.

**NOTE**

Perform steps 10 through 12 if bushings or brackets are damaged or not within wear limits.

10. Press bushings (10), (24), and (29) from brackets (5), (23), and (30).
11. Install bushings (10) and (24) in brackets (5) and (23) with press until bushings (10) and (24) ends are flush with inward side surface of brackets (5) and (23).
12. Install bushing (29) in bracket (30) with press until bushing (29) ends extend 0.5 in. (12.7 mm) from bracket (30) sides.
13. Inspect levers (4) and (28) for wear, latch, handle, or rod change. Refer to table 12-1, M49A2C Discharge Valve Control Lever Wear Limits, for measurements. Replace levers (4) and (28) if not within wear limits.
14. Inspect lever shaft (8) for grooves or wear. Refer to table 12-1, M49A2C Discharge Valve Control Lever Wear Limits, for measurements. Replace lever shaft (8) if not within wear limits.
15. Inspect springs (22) and (31) for distorted or broken coils. Replace springs (22) and (31) if distorted or coils are broken.

## 12-21. DISCHARGE VALVE CONTROL LEVERS MAINTENANCE (M49A2C) (Contd)

16. Inspect spacer bar (1) for cracks or damage. Replace spacer bar (1) if cracked or damaged.
17. Inspect six screws (2) and (6) and two setscrews (12) and (20). Replace screws (2) and (6) and setscrews (12) and (20) if threads are damaged.

### d. Assembly

1. Install clevis (26) on lever arm (21) with pin (25) and new cotter pin (27).
2. Install spacer bar (1) on brackets (5), (30), and (23) with three new lockwashers (3) and screws (2). Do not tighten screws (2).
3. Install lever shaft (8) through bracket (5), lever (4), bracket (30), lever (28), and bracket (23) with three new lockwashers (7) and screws (6).
4. Place lever arm (14) on bushing (29), lever arm (21) on bushing (24), roller (11) on bushing (10), and roller (18) on bushing (29).
5. Position cam (13) with tab down between lever arm (14) and roller (11). Install cam (13) by inserting shaft (9) through bushing (10) and cam (13) and into bushing (29).
6. Position cam (19) with tab down between lever arm (21) and roller (18). Install cam (19) by inserting shaft (9) through bushing (29) and cam (19) and into bushing (24).
7. Install setscrews (12) and (20) in cams (13) and (19).
8. Install fuseable link (17) on bracket (30) and lever arm (14) with new cotter pins (15) and (16).
9. Install spring (31) on bracket (30) and lever arm (14).
10. Install spring (22) on bracket (23) and lever arm (21).
11. Tighten three screws (2).

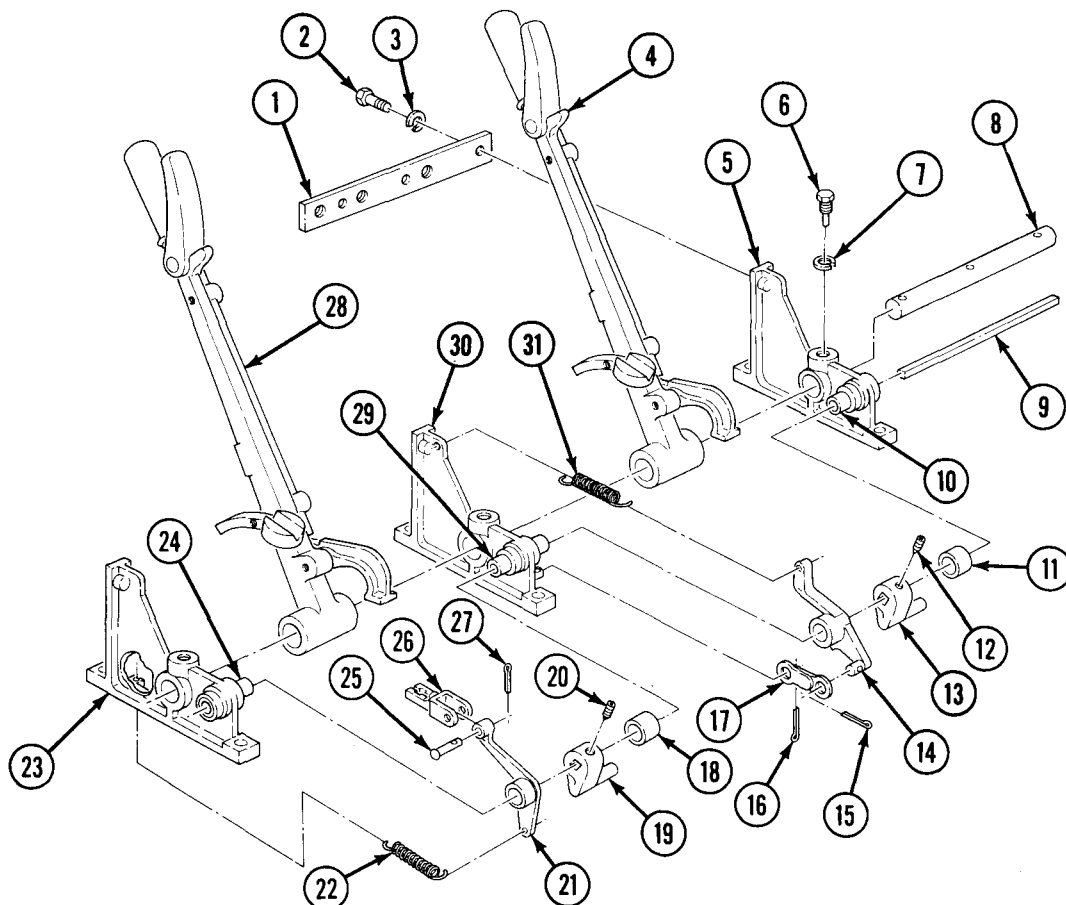

**12-21. DISCHARGE VALVE CONTROL LEVERS MAINTENANCE (M49A2C) (Contd)**

1. Position three cables (12) through adapters (13) and plate (11).
2. Install discharge valve control assembly (5) and spacer (6) in compartment (9) with six screws (4) and new locknuts (7).
3. Install three adapters (13) to plate (11).
4. Thread three cables (12) through holes in bolts (3).
5. Install three bolts (3) on levers (10) with nuts (8). Do not tighten.
6. Install three coupling nuts (1) and tubes (2) on adapters (13).
7. Remove slack in three cables (12) and tighten nuts (8).

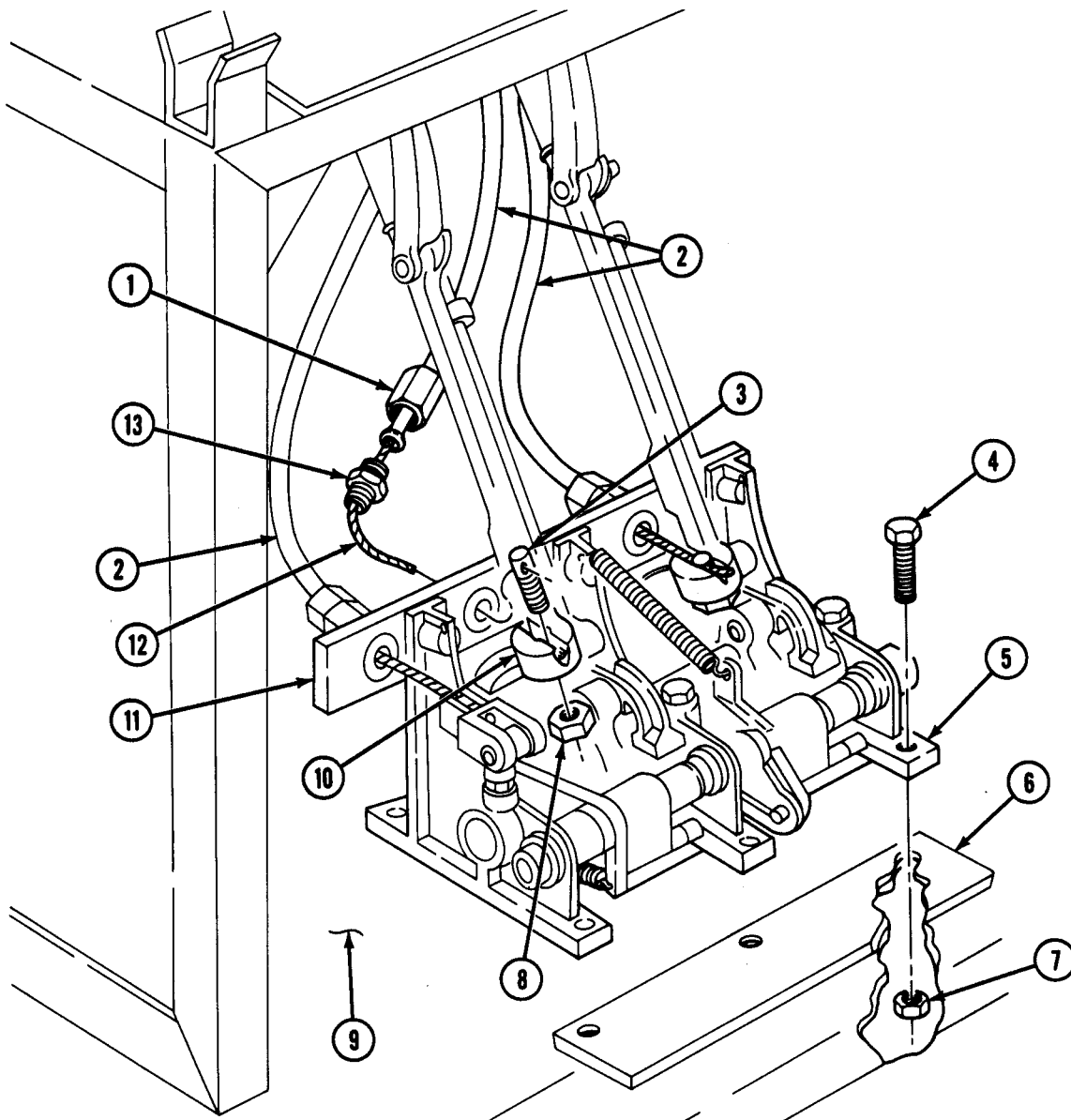

## 12-22. FRONT AND REAR FUEL TANK DISCHARGE TUBES REPLACEMENT (M49A2C)

This task covers:

### a. Removal

### b. Installation

#### INITIAL SETUP:

##### APPLICABLE MODELS

M49A2C

##### MATERIALS/PARTS

Two gaskets  
Six locknuts

##### REFERENCES (TM)

TM 9-2320-361-10  
TM 9-2320-361-20P

##### EQUIPMENT CONDITION

- Parking brake set (TM 9-2320-361-10).
- Fuel tanks drained (TM 9-2320-361-10).

##### GENERAL SAFETY INSTRUCTIONS

Keep fire extinguisher nearby when working on fuel tank trucks.

### WARNING

Do not perform this procedure while smoking or within 50 feet of sparks or open flame. Fuel is flammable and can explode easily, causing injury or death to personnel and damage to equipment.

### NOTE

- Removal and installation of front and rear fuel tank discharge tubes is the same except for two U-bolts on the rear tube and three U-bolts on the front tube. This procedure describes removal and installation of the front tube.
- Access to nuts, screws, coupling, and gasket for removal and installation is through vehicle rear compartment.

1. Remove two nuts (2), screws (3), coupling (1), and gasket (6) from discharge tube (4) and manifold (5). Discard gasket (6).

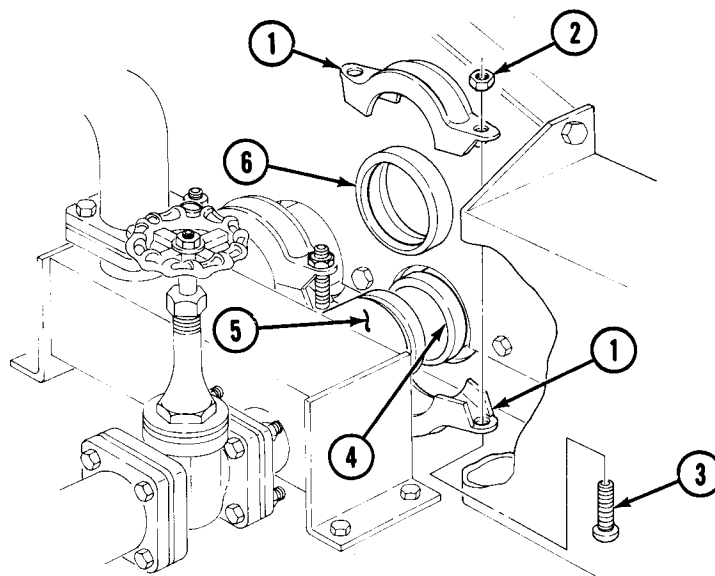

**12-22. FRONT AND REAR FUEL TANK DISCHARGE TUBES REPLACEMENT (M49A2C) (Contd)**

2. Remove six locknuts (3) and three U-bolts (9) from discharge tube (1) and frame (2). Discard locknuts (3).
3. Remove two nuts (8), screws (4), coupling (5), and gasket (7) from discharge tube (1) and discharge valve (6). Discard gasket (7).
4. Remove discharge tube (1) from discharge valve (6), manifold (14), and frame (2).

**b. Installation**

1. Position discharge tube (1) on discharge valve (6).
2. Install new gasket (10) and discharge tube (1) on manifold (14) with coupling (11), two screws (13), and nuts (12).
3. Install new gasket (7) and discharge tube (1) on discharge valve (6) with coupling (5), two screws (4), and nuts (8).
4. Install discharge tube (1) on frame (2) with three U-bolts (9) and six new locknuts (3).

12-22. FRONT AND REAR FUEL TANK DISCHARGE TUBES REPLACEMENT (M49A2C) (Contd)

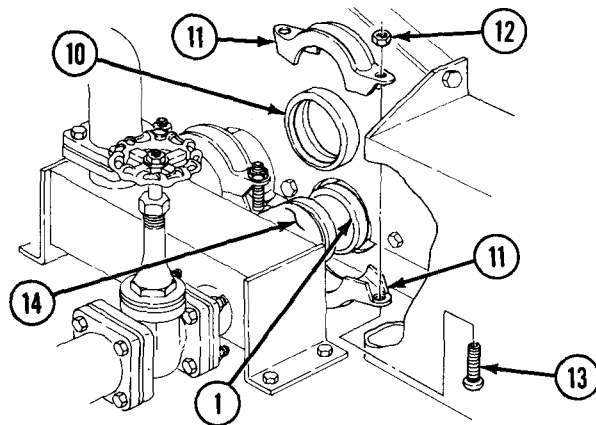
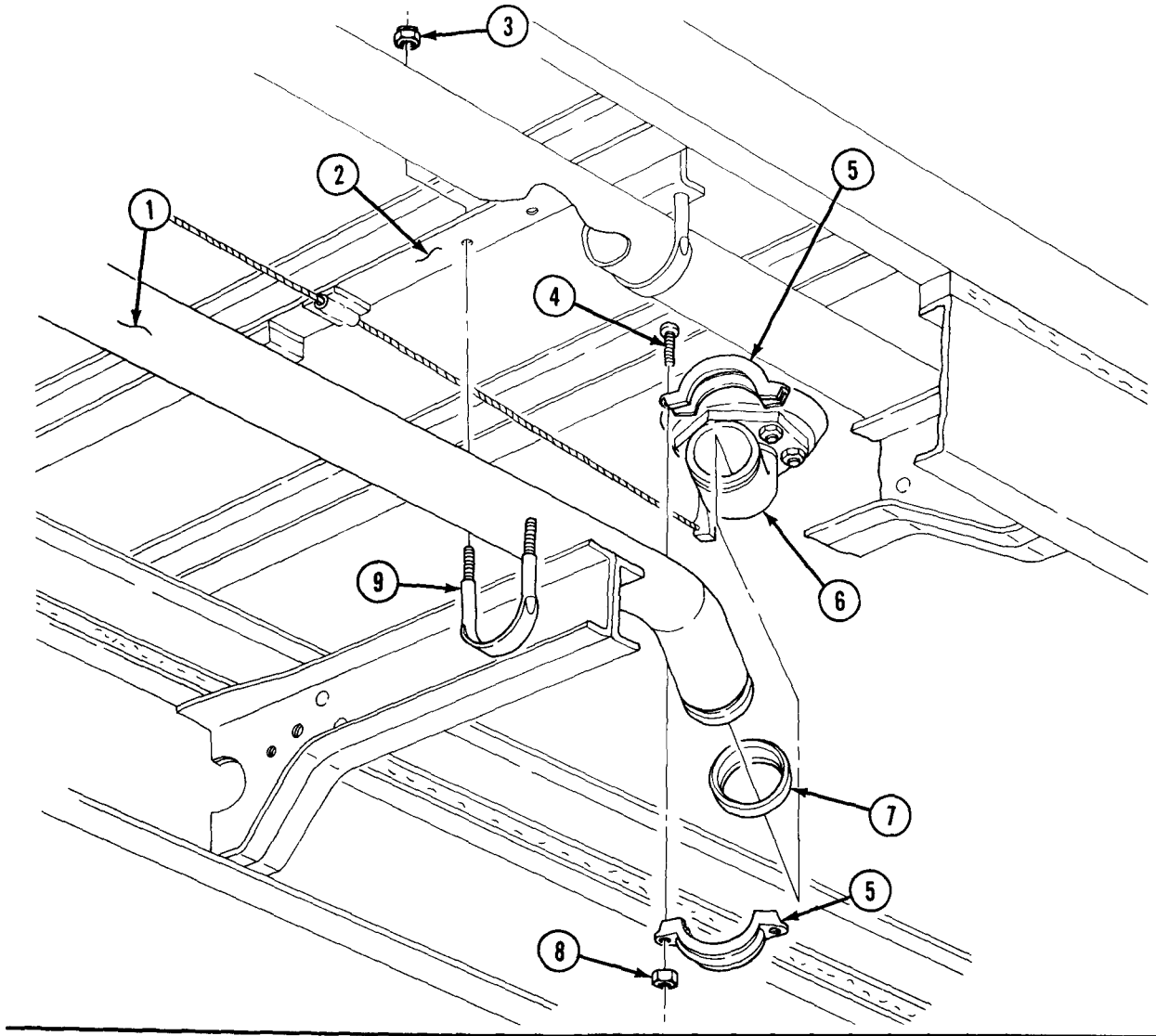

FOLLOW-ON TASK: Fill fuel tanks (TM 9-2320-361-10) and check for leaks.

**12-23. FUEL TANK MANHOLE COVER MAINTENANCE (M49A2C)**

This task covers:

- a. Removal
- b. Disassembly
- c. Inspection

- d. Assembly
- e. Installation

**INITIAL SETUP:**

APPLICABLE MODELS

M49A2C

MATERIALS/PARTS

Two gaskets  
Fill gasket

REFERENCES (TM)

TM 9-2320-361-10  
TM 9-2320-361-20P

EQUIPMENT CONDITION

- Parking brake set (TM 9-2320-361-10).
- Fuel tanks drained (TM 9-2320-361-10).

GENERAL SAFETY INSTRUCTIONS

Keep fire extinguisher nearby when working on fuel tank trucks.

**WARNING**

Do not perform this procedure while smoking or within 50 feet of sparks or open flame. Fuel is flammable and can explode easily, causing injury or death to personnel and damage to equipment.

**NOTE**

Cover manhole opening in tank to avoid contamination.

**a. Removal**

1. Remove nut (12), washer (13), screw (14), and clamp ring (10) from manhole cover (15) and tank body (11).
2. Remove manhole cover (15) and gasket (9) from tank body (11). Discard gasket (9).

**b. Disassembly**

1. Remove nut (18), springwell (17), spring (16), and screw (8) from fill cover (6) and latch (7).
2. Unscrew vent valve (1), and remove washer (2), gasket (3), fill retainer (4), fill gasket (5), and fill cover (6). Discard fill gasket (5) and gasket (3).

**c. Inspection**

1. Inspect manhole cover (15), spring (16), and clamp ring (10) for cracks, bends, and damage. Replace manhole cover (15), spring (16), or clamp ring (10) if cracked, bent, or damaged.
2. Inspect vent valve (1) for stripped threads. Replace vent valve (1) if threads are stripped or damaged.

**d. Assembly**

1. Install new fill gasket (5), fill retainer (4), new gasket (3), washer (2), and vent valve (1) on fill cover (6).
2. Install screw (8), spring (16), springwell (17), and nut (18) on fill cover (6) and latch (7).

**12-23. FUEL TANK MANHOLE COVER MAINTENANCE (M49A2C) (Contd)****e. Installation**

1. Install new gasket (9) and manhole cover (15) on tank body (11).
2. Install clamp ring (10) around manhole cover (15) and tank body (11) with screw (14), washer (13), and nut (12).

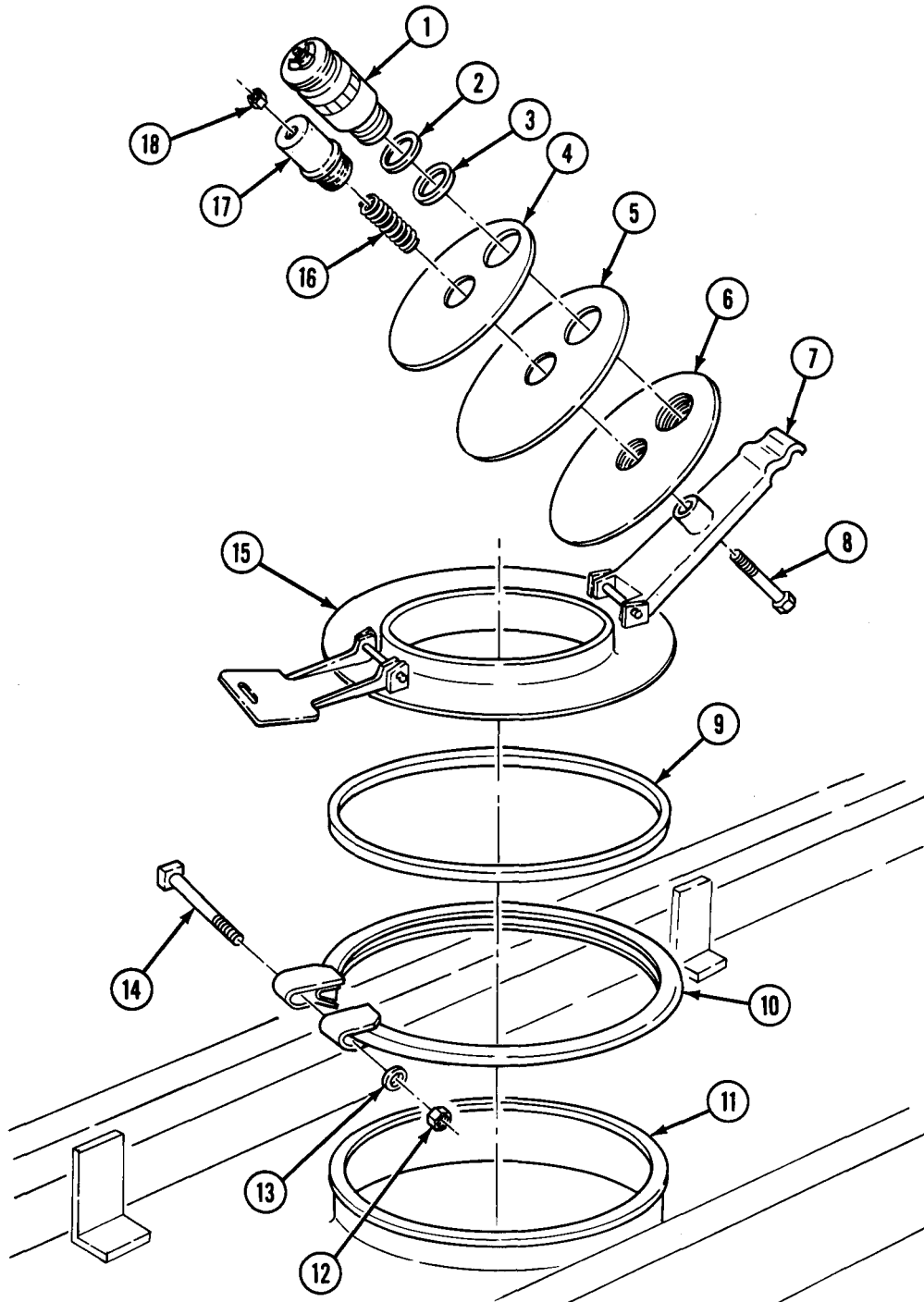

FOLLOW-ON TASK: Fill fuel tanks (TM 9-2320-361-10) and check for leaks.



**12-24. FUEL HOSE AND NOZZLE REPLACEMENT (M49A2C)**

This task covers:

**a. Removal**

**b. Installation**

**INITIAL SETUP:**

APPLICABLE MODELS

M49A2C

MATERIALS/PARTS

Gasket

Antiseize tape (Appendix C, Item 27)

REFERENCES (TM)

TM 9-2320-361-10

TM 9-2320-361-20P

EQUIPMENT CONDITION

- Parking brake set (TM 9-2320-361-10).
- Fuel tanks drained (TM 9-2320-361-10).

GENERAL SAFETY INSTRUCTIONS

Keep fire extinguisher nearby when working on fuel tank trucks.

**WARNING**

Do not perform this procedure while smoking or within 50 feet of sparks or open flame. Fuel is flammable and can explode easily, causing injury or death to personnel and damage to equipment.

**CAUTION**

All valves must be in OFF position.

**a. Removal**

1. Remove nozzle (11) from bushing (12).
2. Remove bushing (12) from fitting (13).
3. Remove fitting (13) from hose (1).
4. Remove two nuts (10), screws (6), coupling (7), and gasket (8) from meter outlet tube (9) and tube (5). Discard gasket (8).
5. Remove tube (5) from fitting (4).
6. Remove fitting (4) from swivel (3).
7. Remove swivel (3) from bushing (2).
8. Remove bushing (2) from hose (1).

**b. Installation**

**NOTE**

Male pipe threads must be wrapped with antiseize tape before installation.

1. Install bushing (2) on hose (1).
2. Install swivel (3) on bushing (2).
3. Install fitting (4) on swivel (3).
4. Install tube (5) on fitting (4).
5. Install tube (5) and new gasket (8) on meter outlet tube (9) with coupling (7), two screws (6), and nuts (10).
6. Install fitting (13) on hose (1).
7. Install bushing (12) on fitting (13).
8. Install nozzle (11) on bushing (12).

**12-24. FUEL HOSE AND NOZZLE REPLACEMENT (M49A2C) (Contd)**

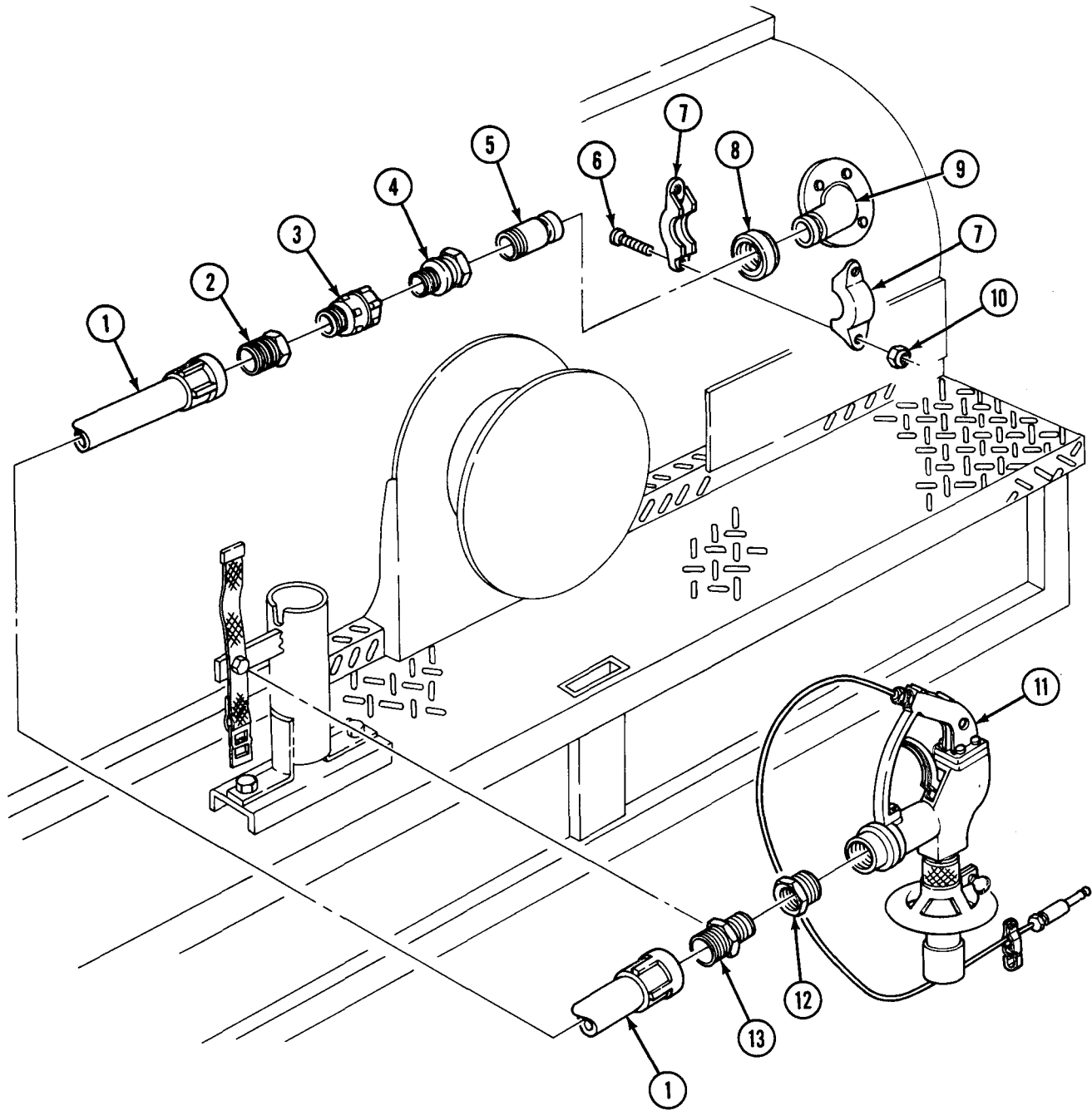

FOLLOW-ON TASK: Fill fuel tanks (TM 9-2320-361-10) and check for leaks.

**12-25. FUEL AND WATER TANK NOZZLE HOLDER REPLACEMENT**

This task covers:

**a. Removal**

**b. Installation**

**INITIAL SETUP:**

APPLICABLE MODELS

M49A2C, M50A2, M50A3

EQUIPMENT CONDITION

Parking brake set (TM 9-2320-361-10).

MATERIALS/PARTS

Three locknuts

REFERENCES (TM)

TM 9-2320-361-10

TM 9-2320-361-20P

**a. Removal**

1. Remove two locknuts (5), screws (6), and nozzle holder (3) from bracket (4). Discard locknuts (5).
2. Remove screw (7), locknut (2), washer (8), and strap (1) from nozzle holder (3). Discard locknut (2).

**b. Installation**

1. Install strap (1) on nozzle holder (3) with washer (8), new locknut (2), and screw (7).
2. Install nozzle holder (3) on bracket (4) with two screws (6) and new locknuts (5).

## 12-26. OVERTURN TUBES REPLACEMENT (M49A2C)

This task covers:

### a. Removal

### b. Installation

#### INITIAL SETUP:

##### APPLICABLE MODELS

M49A2C

##### EQUIPMENT CONDITION

Parking brake set (TM 9-2320-361-10).

##### REFERENCES (TM)

TM 9-2320-361-10

TM 9-2320-361-20P

##### GENERAL SAFETY INSTRUCTIONS

Keep fire extinguisher nearby when working on fuel tank trucks.

### WARNING

Do not perform this procedure while smoking or within 50 feet of sparks or open flame. Fuel is flammable and can explode easily, causing injury or death to personnel and damage to equipment.

#### a. Removal

1. Loosen clamps (1) on top and bottom of overturn tube (3).
2. Push tube (3) down, onto bottom adapter (4) as far as possible, and remove from adapter (2).
3. Remove tube (3) from adapter (4).

#### b. Installation

1. Install clamps (1) on top and bottom of tube (3).
2. Install tube (3) and push down as far as possible on bottom adapter (4).
3. Install top of tube (3) on top adapter (2). Adjust tube (3) evenly on top adapter (2) and bottom adapter (4) and tighten clamps (1).

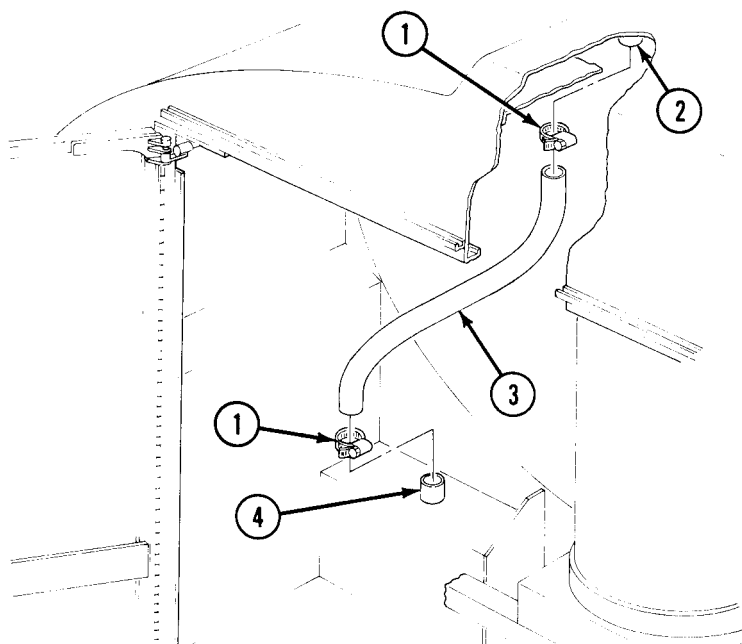

## 12-27. GLOBE VALVE REPLACEMENT (M49A2C)

This task covers:

### a. Removal

### b. Installation

#### INITIAL SETUP:

##### APPLICABLE MODELS

M49A2C

##### MATERIALS/PARTS

Antiseize tape (Appendix C, Item 27)

##### REFERENCES (TM)

TM 9-2320-361-10

TM 9-2320-361-20P

##### EQUIPMENT CONDITION

- Parking brake set (TM 9-2320-361-10).
- Fuel tanks drained (TM 9-2320-361-10).

##### GENERAL SAFETY INSTRUCTIONS

Keep fire extinguisher nearby when working on fuel tank trucks.

### WARNING

Do not perform this procedure while smoking or within 50 feet of sparks or open flame. Fuel is flammable and can explode easily, causing injury or death to personnel and damage to equipment.

#### NOTE

Have drainage container ready to catch fuel.

### a. Removal

1. Open globe valve (3) and allow fuel to drain from piping (1).
2. Remove fitting (4) from hose (5) and valve (3).
3. Remove valve (3) from fitting (2).
4. Remove fitting (2) from pipe (1).

### b. Installation

1. Apply antiseize tape to threads on fittings (2) and (4).
2. Install fitting (2) to pipe (1).
3. Install valve (3) to fitting (2).
4. Install fitting (4) to valve (3) and hose (5).

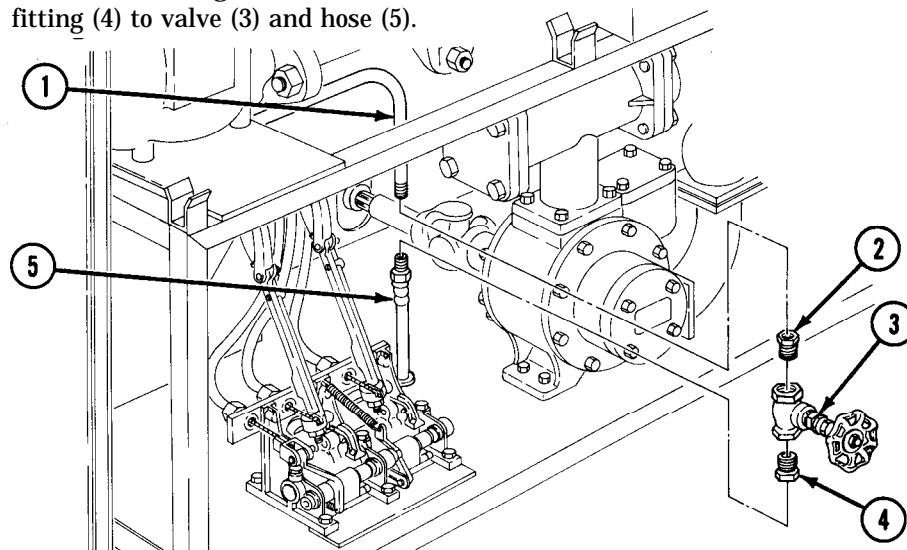

FOLLOW-ON TASK: Fill fuel tanks (TM 9-2320-361-10) and check for leaks.

## 12-28. FILTER SEPARATOR-TO-SUMP PIPE REPLACEMENT (M49A2C)

This task covers:

### a. Removal

### b. Installation

#### INITIAL SETUP:

##### APPLICABLE MODELS

M49A2C

##### MATERIALS/PARTS

Two gaskets

##### REFERENCES (TM)

TM 9-2320-361-10

TM 9-2320-361-20P

##### EQUIPMENT CONDITION

- Parking brake set (TM 9-2320-361-10).
- Fuel tanks drained (TM 9-2320-361-10).

##### GENERAL SAFETY INSTRUCTIONS

Keep fire extinguisher nearby when working on fuel tank trucks.

### WARNING

Do not perform this procedure while smoking or within 50 feet of sparks or open flame. Fuel is flammable and can explode easily, causing injury or death to personnel and damage to equipment.

### a. Removal

Remove four screws (2), nuts (5), two couplings (3), filter separator-to-pump pipe (1), and two gaskets (6) from sump valve housing (4) and filter separator (7). Discard gaskets (6).

### b. Installation

Install two new gaskets (6) and filter separator-to-sump pipe (1) on sump valve housing (4) and filter separator (7) with two couplings (3), four screws (2), and nuts (5).

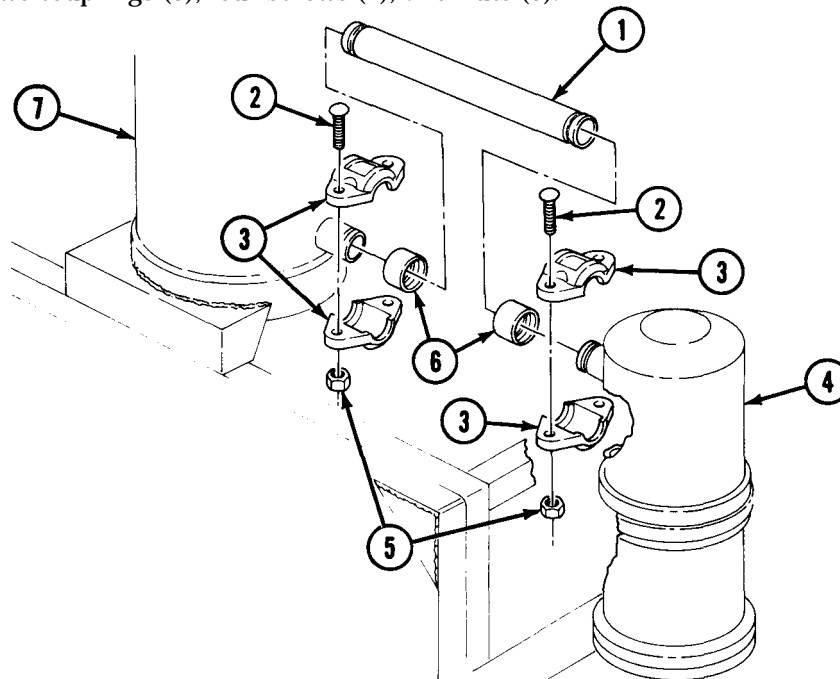

FOLLOW-ON TASK: Fill fuel tanks (TM 9-2320-361-10) and check for leaks.

## 12-29. STATIC REEL REPLACEMENT (M49A2C)

This task covers:

**a. Removal**

**b. Installation**

**INITIAL SETUP:**

APPLICABLE MODELS

M49A2C

MATERIALS/PARTS

Two locknuts

REFERENCES (TM)

TM 9-2320-361-10

TM 9-2320-361-20P

EQUIPMENT CONDITION

Parking brake set (TM 9-2320-361-10).

GENERAL SAFETY INSTRUCTIONS

Keep fire extinguisher nearby when working on fuel tank trucks.

**WARNING**

Do not perform this procedure while smoking or within 50 feet of sparks or open flame. Fuel is flammable and can explode easily causing injury or death to personnel and damage to equipment.

**a. Removal**

Remove two locknuts (3), screws (4), and static reel (1) from shelf (2). Discard locknuts (4).

**b. Installation**

Install static reel (1) on shelf (2) with two screws (4) and new locknuts (3).

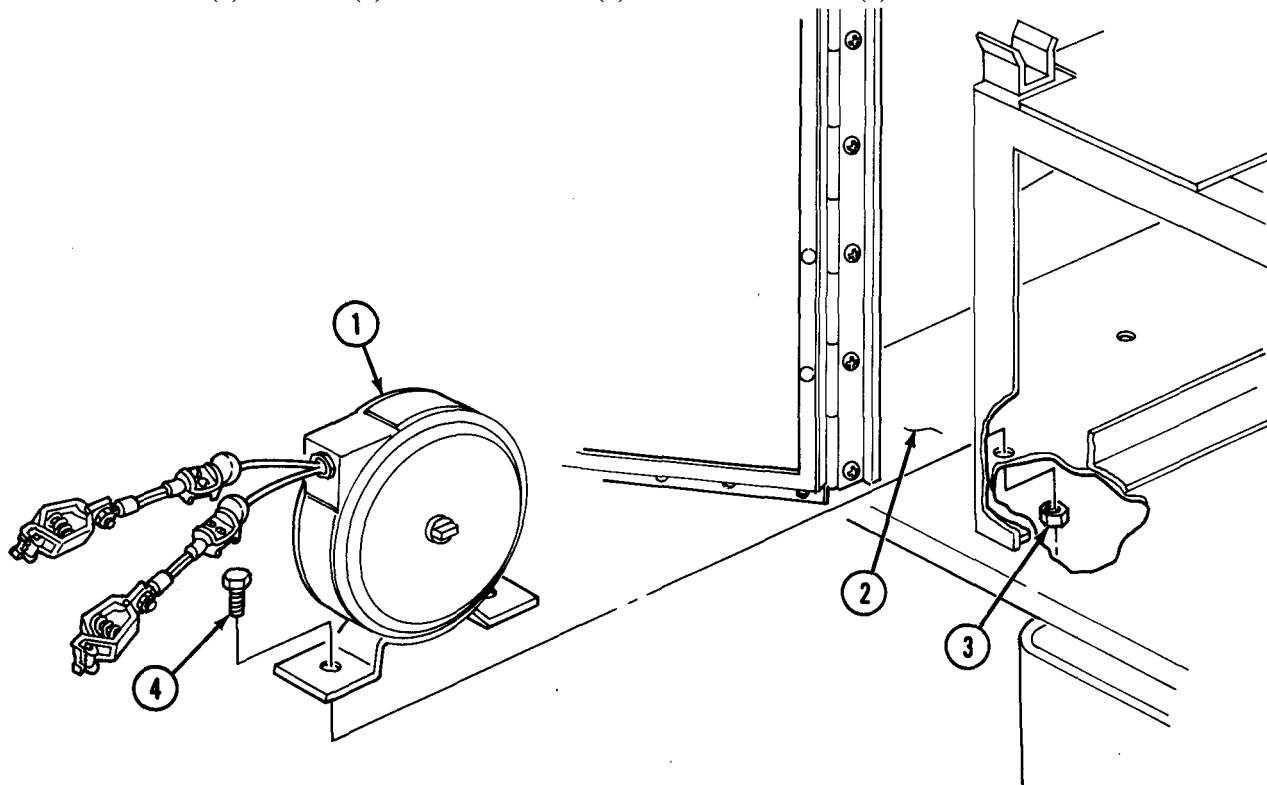

## 12-30. METER-TO-FILTER TUBE REPLACEMENT (M49A2C)

This task covers:

### a. Removal

### b. Installation

#### INITIAL SETUP:

##### APPLICABLE MODELS

M49A2C

##### MATERIALS/PARTS

Two locknuts

Two gaskets

##### REFERENCES (TM)

TM 9-2320-361-10

TM 9-2320-361-20P

##### EQUIPMENT CONDITION

Parking brake set (TM 9-2320-361-10).

##### GENERAL SAFETY INSTRUCTIONS

Keep fire extinguisher nearby when working on fuel tank trucks.

#### WARNING

Do not perform this procedure while smoking or within 50 feet of sparks or open flame. Fuel is flammable and can explode easily, causing injury or death to personnel and damage to equipment.

#### NOTE

Have drainage container ready to catch fuel.

### a. Removal

1. Remove two nuts (6), screws (3), and coupling (4) from tube (8) and filter separator (2).
2. Remove two locknuts (10), screws (7), tube (8), and gaskets (9) and (5) from meter (1) and filter separator (2). Discard locknuts (10) and gaskets (9) and (5).

### b. Installation

1. Install new gasket (9), tube (8), and new gasket (5) on filter separator (2) and meter (1) with two screws (7) and new locknuts (10). Do not tighten locknuts (10).
2. Install coupling (4) on filter separator (2) and gasket (5) with two screws (3) and nuts (6). Tighten locknuts (10).

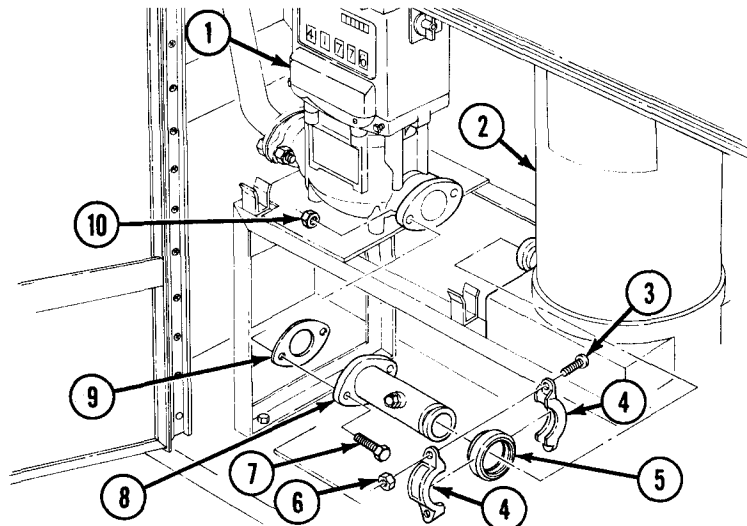



**12-31. GALLON METER REPLACEMENT (M49A2C)**

This task covers:

**a. Removal**

**b. Installation**

**INITIAL SETUP:**

APPLICABLE MODELS

M49A2C

MATERIALS/PARTS

Three lockwashers

REFERENCES (TM)

TM 9-2320-361-10

TM 9-2320-361-20P

EQUIPMENT CONDITION

- Parking brake set (TM 9-2320-361-10).
- Meter outlet tube removed (para. 12-37).
- Globe valve removed (para. 12-27).
- Meter-to-filter tube removed (para. 12-30).

**a. Removal**

1. Remove three screws (4), lockwashers (5), and gallon meter (1) from shelf (6). Discard lockwashers (5).
2. Remove pipe (3) from elbow (2) and elbow (2) from gallon meter (1).

**b. Installation**

1. Install elbow (2) on gallon meter (1) and pipe (3) on elbow (2).
2. Install gallon meter (1) on shelf (6) with three screws (4) and new lockwashers (5).

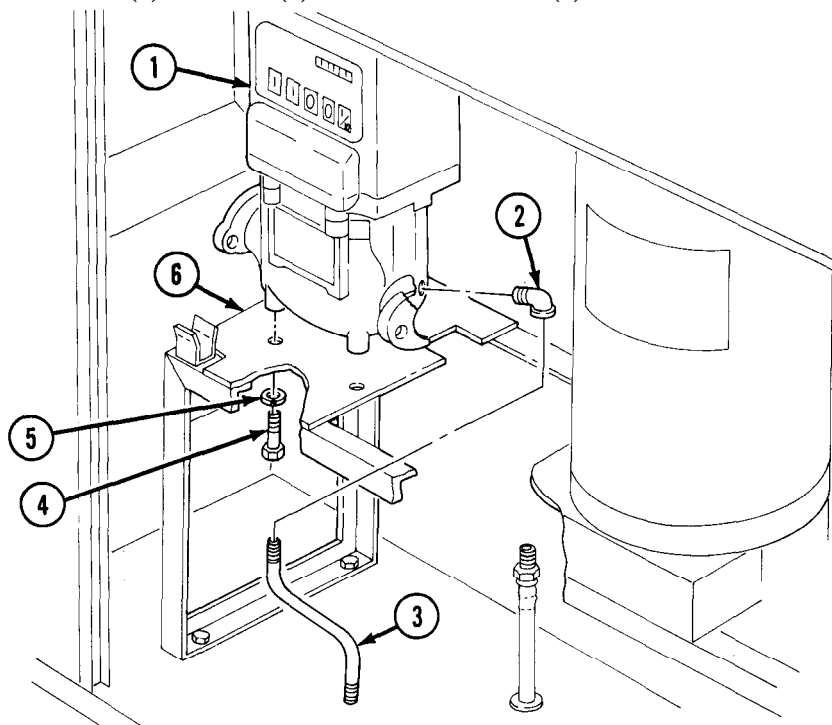

- FOLLOW-ON TASKS:**
- Install meter-to-filter tube (para. 12-37).
  - Install globe valve (para. 12-27).
  - Install meter outlet tube (para. 12-30).

## 12-32. DELIVERY PUMP OUTLET TUBE REPLACEMENT (M49A2C)

This task covers:

### a. Removal

### b. Installation

#### INITIAL SETUP:

##### APPLICABLE MODELS

M49A2C

##### MATERIALS/PARTS

Two gaskets  
Four lockwashers  
Four locknuts

##### REFERENCES (TM)

TM 9-2320-361-10  
TM 9-2320-361-20P

##### EQUIPMENT CONDITION

Parking brake set (TM 9-2320-361-10).

##### GENERAL SAFETY INSTRUCTIONS

Keep fire extinguisher nearby when working on fuel tank trucks.

### **WARNING**

Do not perform this procedure while smoking or within 50 feet of sparks or open flame. Fuel is flammable and can explode easily, causing injury or death to personnel and damage to equipment.

### **NOTE**

Have drainage container ready to catch fuel.

### **a. Removal**

1. Remove four screws (7), lockwashers (8), and gasket (9) from outlet tube (5) and delivery pump (1). Discard lockwashers (8) and gasket (9). Remove gasket remains from mating surfaces.
2. Remove four screws (6), locknuts (2), gasket (4), and outlet tube (5) from gate valve (3). Discard locknuts (2) and gasket (4). Remove gasket remains from mating surfaces.

### **b. Installation**

1. Install new gasket (9) and outlet tube (5) on delivery pump (1) with four screws (7) and new lockwashers (8).
2. Install new gasket (4) and outlet tube (5) on gate valve (3) with four screws (6) and new locknuts (2).

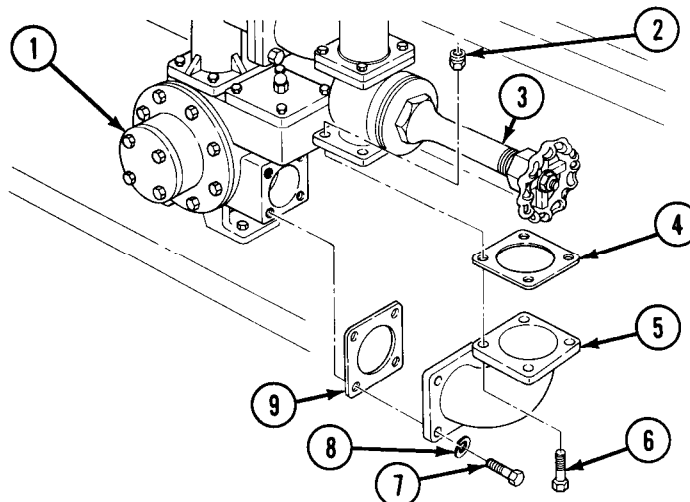

## 12-33. DELIVERY PUMP INLET TUBE REPLACEMENT (M49A2C)

This task covers:

### a. Removal

### b. Installation

#### INITIAL SETUP:

#### APPLICABLE MODELS

M49A2C

#### REFERENCES (TM)

TM 9-2320-361-10

TM 9-2320-361-20P

#### MATERIALS/PARTS

Four lockwashers

Four locknuts

Two gaskets

#### EQUIPMENT CONDITION

Parking brake set (TM 9-2320-361-10).

#### GENERAL SAFETY INSTRUCTIONS

Keep fire extinguisher nearby when working on fuel tank trucks.

### WARNING

Do not perform this procedure while smoking or within 50 feet of sparks or open flame. Fuel is flammable and can explode easily, causing injury or death to personnel and damage to equipment.

#### NOTE

Have drainage container ready to catch fuel.

### a. Removal

1. Loosen two clamps (6) on hose (5).
2. Remove four locknuts (11), screws (7), elbow (8), and gasket (9) from discharge manifold (10). Discard locknuts (11) and gasket (9).
3. Remove two clamps (6) and hose (5) from inlet tube (2) and elbow (8).
4. Remove four screws (4), lockwashers (3), inlet tube (2), and gasket (1) from delivery pump (12). Discard lockwashers (3) and gasket (1).

### b. Installation

1. Install new gasket (1) and inlet tube (2) on delivery pump (12) with four screws (4) and new lockwashers (3).
2. Install hose (5) and two clamps (6) on inlet tube (2) and elbow (8). Do not tighten clamps (6).
3. Install new gasket (9) and elbow (8) on discharge manifold (10) with four screws (7) and new locknuts (11). Tighten clamps (6).

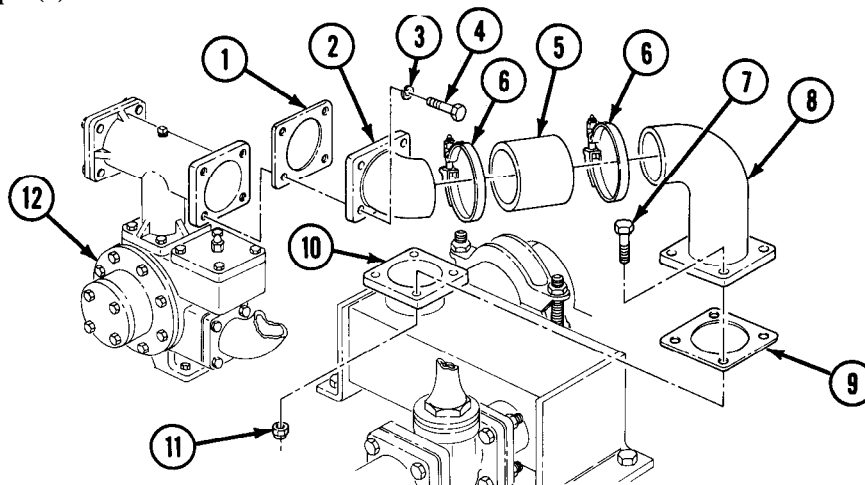

## 12-34. WATER PUMP MANIFOLD REPLACEMENT (M50A2, M50A3)

This task covers:

### a. Removal

### b. Installation

#### INITIAL SETUP:

##### APPLICABLE MODELS

M50A2, M50A3

##### MATERIALS/PARTS

Three gaskets

Eight locknuts

##### REFERENCES (TM)

TM 9-2320-361-10

TM 9-2320-361-20P

##### EQUIPMENT CONDITION

Parking brake set (TM 9-2320-361-10).

### a. Removal

1. Remove two nuts (19), screws (16), coupling (17), and gasket (18) from elbow (1) and manifold (11). Discard gasket (18).
2. Remove two nuts (5), screws (3), coupling (2), and gasket (7) from discharge tube (4) and manifold (11). Discard gasket (7).
3. Remove four locknuts (8), screws (14), gasket (13), and gate valve (15) from manifold flange (12). Discard gasket (13) and locknuts (8).
4. Remove four locknuts (9), screws (10), and manifold (11) from compartment (6). Discard locknuts (9).

### b. Installation

1. Install manifold (11) in compartment (6) with four screws (10) and new locknuts (9).
2. Install new gasket (13) and gate valve (15) on manifold flange (12) with four screws (14) and new locknuts (8).
3. Install manifold (11) on discharge tube (4) with new gasket (7), coupling (2), two screws (3), and nut (5).
4. Install new gasket (18) and elbow (1) on manifold (11) with coupling (17), two screws (16), and nuts (19).

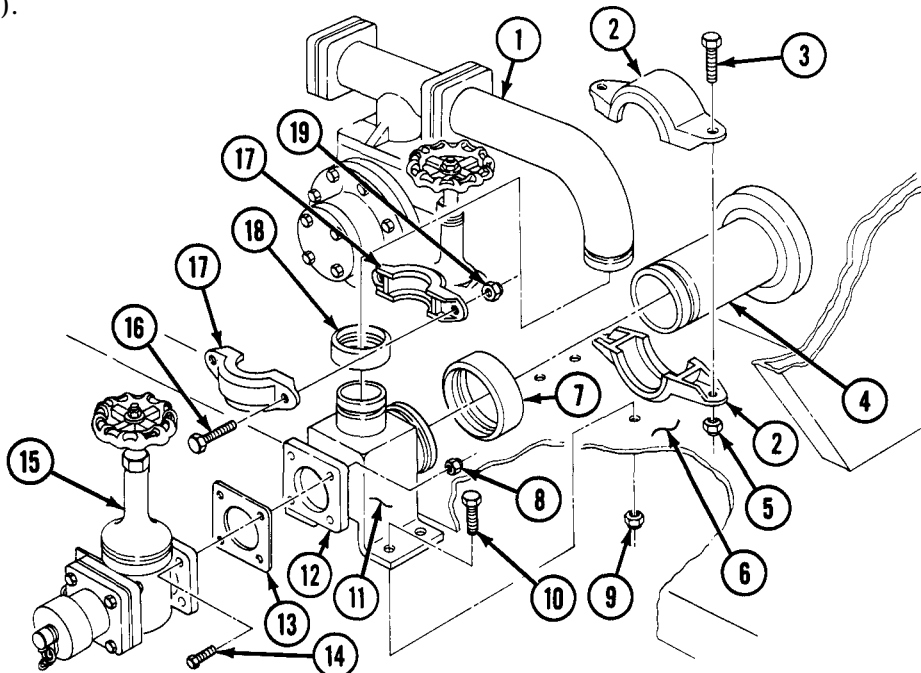

## 12-35. DELIVERY PUMP REPLACEMENT

This task covers:

### a. Removal

### b. Installation

#### INITIAL SETUP:

##### APPLICABLE MODELS

M49A2C, M50A2, M50A3

##### MATERIALS/PARTS

Four locknuts

Key

##### REFERENCES (TM)

LO 9-2320-209-12-1

TM 9-2320-361-10

TM 9-2320-361-20P

##### EQUIPMENT CONDITION

- Parking brake set (TM 9-2320-361-10).
- Delivery pump draincock removed (para. 12-36).
- Delivery pump inlet tube removed (para. 12-33).
- Delivery pump outlet tube removed (para. 12-32).

##### GENERAL SAFETY INSTRUCTIONS

Keep fire extinguisher nearby when working on fuel tank trucks.

### WARNING

Do not perform this procedure while smoking or within 50 feet of sparks or open flame. Fuel is flammable and can explode easily, causing injury or death to personnel and damage to equipment.

### a. Removal

1. Remove setscrew (1) from delivery pump rear propeller shaft (8) and delivery pump shaft (5).
2. Remove four locknuts (6), screws (3), and delivery pump (2) from compartment shelf (4). Discard locknuts (6).
3. Remove key (7) from delivery pump shaft (5). Discard key (7).

### b. Installation

1. Install new key (7) in delivery pump shaft (5).
2. Position delivery pump (2) in compartment (4).
3. Install delivery pump rear propeller shaft (8) on delivery pump shaft (5) with setscrew (1).
4. Install delivery pump (2) in compartment shelf (4) with four screws (3) and new locknuts (6).

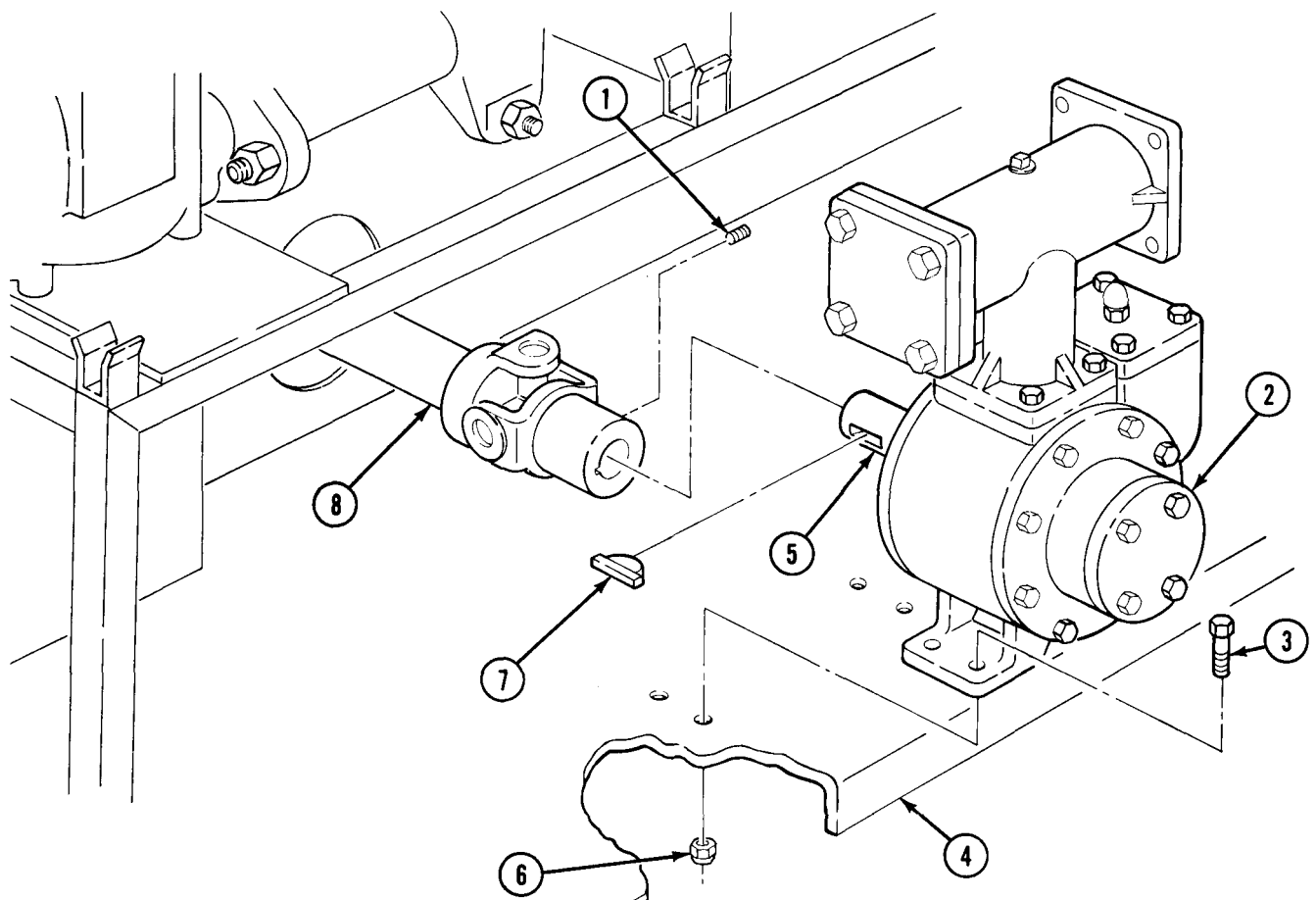
**12-35. DELIVERY PUMP REPLACEMENT (Contd)**

- FOLLOW-ON TASKS:**
- Install delivery pump outlet tube (para. 12-32).
  - Install delivery pump inlet tube (para. 12-33).
  - Install delivery pump draincock (para. 12-36).
  - Lubricate pump and shaft (LO 9-2320-209-12-1).

## 12-36. DELIVERY PUMP DRAINCOCK REPLACEMENT

This task covers:

**a. Removal**

**b. Installation**

**INITIAL SETUP:**

**APPLICABLE MODELS**

M49A2C, M50A2, M50A3

**EQUIPMENT CONDITION**

Parking brake set (TM 9-2320-361-10).

**MATERIALS/PARTS**

Rubber seal (M49A2C, M50A2)

**GENERAL SAFETY INSTRUCTIONS**

Keep fire extinguisher nearby when working on fuel tank trucks.

**REFERENCES (TM)**

TM 9-2320-361-10

TM 9-2320-361-20P

**WARNING**

Do not perform this procedure while smoking or within 50 feet of sparks or open flame. Fuel is flammable and can explode easily, causing injury or death to personnel and damage to equipment.

**NOTE**

- Have drainage container ready to catch fuel.
- Seal is only used on M49A2C and M50A2 vehicles.

**a. Removal**

1. Remove draincock (2) and rubber seal (3) from pump adapter (4). Discard rubber seal (3).
2. Remove pump adapter (4) from drain pipe (1).

**b. Installation**

1. Install pump adapter (4) on pump drain pipe (1).
2. Install new rubber seal (3) and draincock (2) to pump adapter (4).

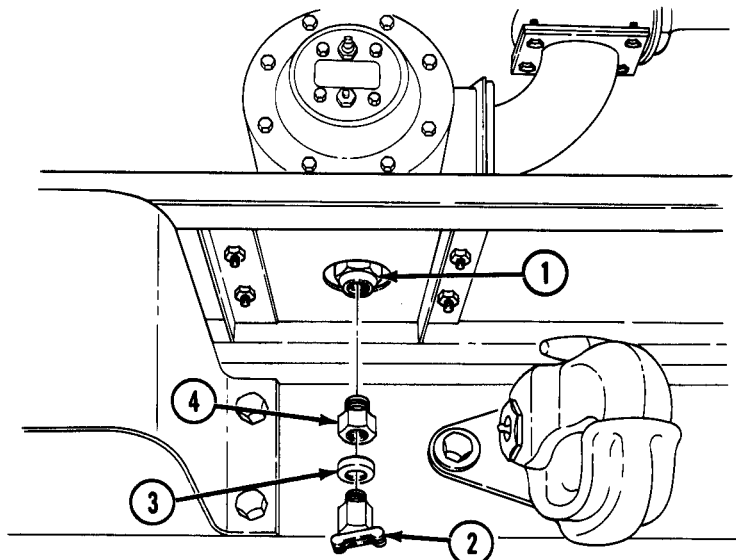

## 12-37. METER OUTLET TUBE REPLACEMENT (M49A2C)

This task covers:

### a. Removal

### b. Installation

#### INITIAL SETUP:

##### APPLICABLE MODELS

M49A2C

##### MATERIALS/PARTS

Two gaskets

Six locknuts

##### REFERENCES (TM)

TM 9-2320-361-10

TM 9-2320-361-20P

##### EQUIPMENT CONDITION

- Parking brake set (TM 9-2320-361-10).
- Fuel hose and nozzle removed (para. 12-24).

##### GENERAL SAFETY INSTRUCTIONS

Keep fire extinguisher nearby when working on fuel tank trucks.

### WARNING

Do not perform this procedure while smoking or within 50 feet of sparks or open flame. Fuel is flammable and can explode easily, causing injury or death to personnel and damage to equipment.

### NOTE

Have drainage container ready to catch fuel.

#### **a. Removal**

1. Remove two locknuts (6), screws (8), and gasket (7) from outlet tube (13) and meter (5). Discard locknuts (6) and gasket (7).
2. Remove two nuts (15), screws (2), coupling (3), and gasket (14), from meter outlet tube (13) and fuel hose tube (1). Discard gasket (14).
3. Remove four locknuts (9), screws (12), plate (11), and grommet (10) from tank body (4). Discard locknuts (9).
4. Remove meter outlet tube (13) from tank body (4).

#### **b. Installation**

1. Install grommet (10) and plate (11) on tank body (4) with four screws (12) and new locknuts (9).
2. Install meter outlet tube (13) through hole in tank body (4).
3. Install new gasket (14) and coupling (3) on meter outlet tube (13) and fuel hose tube (1) with two screws (2) and nuts (15).
4. Install meter outlet tube (13) and new gasket (7) on meter (5) with two screws (8) and new locknuts (6).

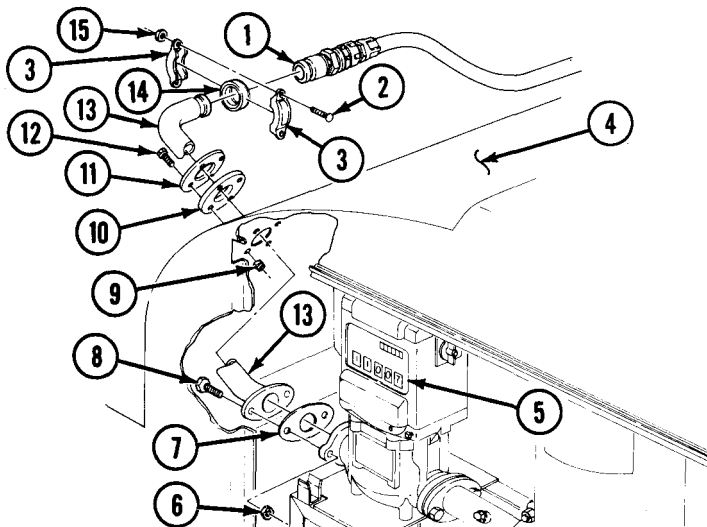

FOLLOW-ON TASK: Install fuel hose and nozzle (para. 12-24).



**12-38. GATE VALVE REPLACEMENT**

This task covers:

**a. Removal**

**b. Installation**

**INITIAL SETUP:**

APPLICABLE MODELS

M49A2C, M50A2, M50A3

EQUIPMENT CONDITION

Parking brake set (TM 9-2320-361-10).

MATERIALS/PARTS

Eight locknuts  
Two gaskets

GENERAL SAFETY INSTRUCTIONS

Keep fire extinguisher nearby when working on fuel tank trucks.

REFERENCES (TM)

TM 9-2320-361-10  
TM 9-2320-361-20P

**WARNING**

Do not perform this procedure while smoking or within 50 feet of sparks or open flame. Fuel is flammable and can explode easily, causing injury or death to personnel and damage to equipment.

**NOTE**

- Have drainage container ready to catch fuel.
- Both gate valves are removed the same way.

**a. Removal**

1. Remove four locknuts (9), screws (7), cover (6), and gasket (8) from gate valve (1). Discard locknuts (9) and gasket (8). Remove gasket remains from mating surfaces.
2. Remove four locknuts (2), screws (5), valve (1), and gasket (4) from manifold flange (3). Discard locknuts (2) and gasket (4). Remove gasket remains from mating surfaces.

**b. Installation**

1. Install new gasket (4) and valve (1) on manifold flange (3) with four screws (5) and new locknuts (2).
2. Install new gasket (8) and cover (6) on valve (1) with four screws (7) and new locknuts (9).

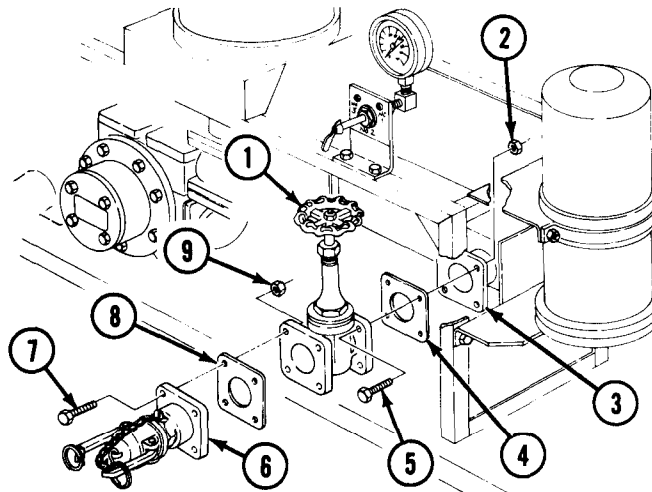

## 12-39. DELIVERY PUMP STRAINER REPLACEMENT

This task covers:

### a. Removal

### b. Installation

#### INITIAL SETUP:

##### APPLICABLE MODELS

M49A2C, M50A2, M50A3

##### EQUIPMENT CONDITION

Parking brake set (TM 9-2320-361-10).

##### MATERIALS/PARTS

Gasket  
Four lockwashers

##### GENERAL SAFETY INSTRUCTIONS

Keep fire extinguisher nearby when working on fuel tank trucks.

##### REFERENCES (TM)

TM 9-2320-361-10  
TM 9-2320-361-20P

### **WARNING**

Do not perform this procedure while smoking or within 50 feet of sparks or open flame. Fuel is flammable and can explode easily, causing injury or death to personnel and damage to equipment.

#### a. Removal

Remove four screws (1), lockwashers (2), cover (6), gasket (5), and strainer (4) from strainer body (3). Discard lockwashers (2) and gasket (5).

#### b. Installation

Install strainer (4), new gasket (5) and cover (6) on strainer body (3) with four new lockwashers (2) and screws (1).

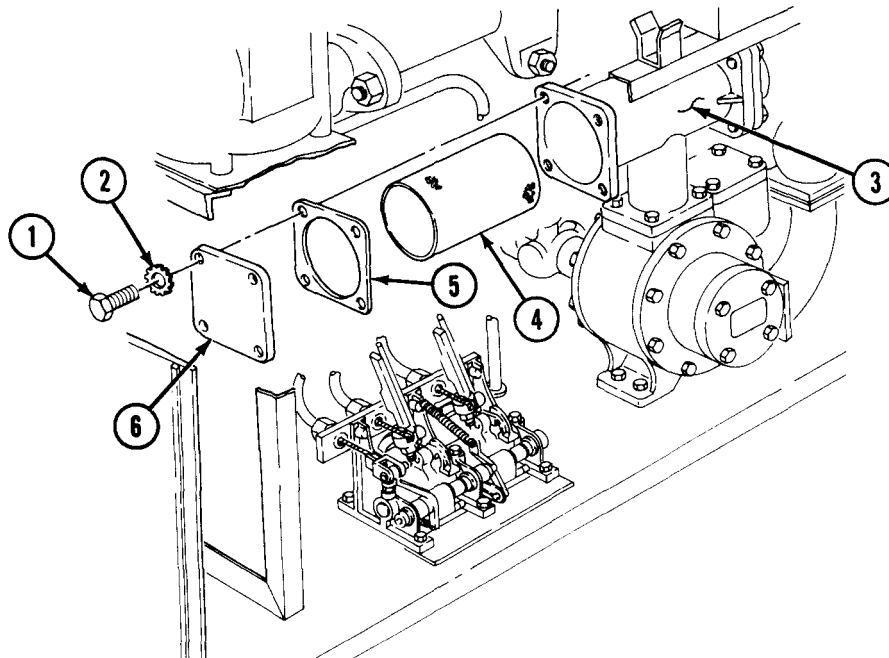

**12-40. SEPARATOR ELEMENT TEST VALVE, GAGE, AND LINES MAINTENANCE (M49A2C)**

This task covers:

- a. Removal
- b. Inspection

c. Installation

**INITIAL SETUP:**

APPLICABLE MODELS

M49A2C

MATERIALS/PARTS

Four locknuts  
Antiseize tape (Appendix C, Item 27)

REFERENCES (TM)

TM 9-2320-361-10  
TM 9-2320-361-20P

EQUIPMENT CONDITION

- Parking brake set (TM 9-2320-361-10),
- Filter separator drained (TM 9-2320-361-10).

GENERAL SAFETY INSTRUCTIONS

Keep fire extinguisher nearby when working on fuel tank trucks.

**WARNING**

Do not perform this procedure while smoking or within 50 feet of sparks or open flame. Fuel is very flammable and can explode easily, causing injury or death to personnel and damage to equipment.

**a. Removal**

1. Remove two tubes (13), line (14), five adapters (3), and elbow (10) from filter separator (1) and selector valve (8).
2. Remove two locknuts (9), screws (5), instruction plate (6), and selector valve (8) from bracket (7). Discard locknuts (9).
3. Remove two locknuts (15), screws (16), and bracket (7) from shelf (2). Discard locknuts (15).
4. Remove gage (11) from elbow (12) and elbow (12) from selector valve (8).

**b. Inspection**

Fittings (4) must be cleaned and inspected for cracks or stripped threads. Replace fittings (4) if threads are cracked or stripped.

**c. Installation**

**NOTE**

Male pipe threads must be wrapped with antiseize tape before installation.

1. Install elbow (12) on selector valve (8).
2. Install gage (11) on elbow (12).
3. Install bracket (7) on shelf (2) with two screws (16) and new locknuts (15).
4. Install selector valve (8) and instruction plate (6) on bracket (7) with two screws (5) and new locknuts (9).
5. Install elbow (10), five adapters (3), line (14), and two tubes (13) to filter separator (1) and selector valve (8).

**12-40. SEPARATOR ELEMENT TEST VALVE, GAGE, AND LINES REPLACEMENT  
(M49A2C) (Contd)**

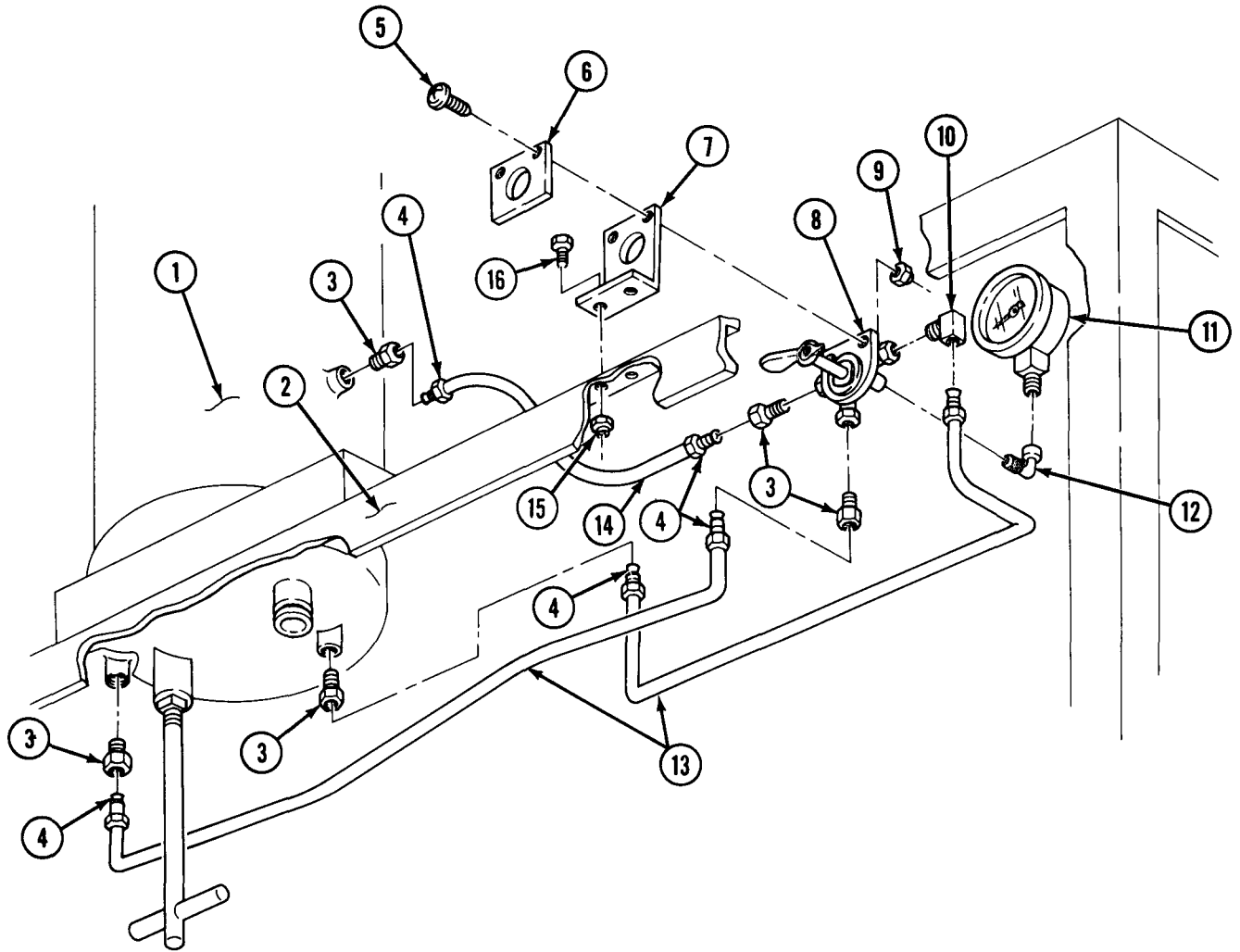

FOLLOW-ON TASK: Fill filter separator (TM 9-2320-361-10).

**12-41. FILTER SEPARATOR MAINTENANCE (M49A2C)**

This task covers:

- a. Removal
- b. Disassembly
- c. Cleaning and Inspection

- d. Assembly
- e. Installation

**INITIAL SETUP:**

**APPLICABLE MODELS**

M49A2C

**MATERIALS/PARTS**

Two gaskets  
 Three filter elements  
 Three fuses  
 Four locknuts  
 Cotter pin  
 Drycleaning solvent (Appendix C, Item 26)  
 Antisieze tape (Appendix C, Item 27)

**PERSONNEL REQUIRED**

Two

**REFERENCES (TM)**

TM 9-2320-361-10  
 TM 9-2320-361-20P

**EQUIPMENT CONDITION**

- Parking brake set (TM 9-2320-361-10).
- Meter-to-filter tube removed (para. 12-30).
- Separator element test valve, gage, and lines removed (para. 12-40).
- Manhole cover removed (para. 12-23).

**GENERAL SAFETY INSTRUCTIONS**

Keep fire extinguisher nearby when working on fuel tank trucks.

**WARNING**

Do not perform this procedure while smoking or within 50 feet of sparks or open flame. Fuel is flammable and can explode easily, causing injury or death to personnel and damage to equipment.

**NOTE**

Have drainage container ready to catch fuel.

**a. Removal**

1. Remove two nuts (19), screws (21), and coupling halves (18) from gasket (16) and filter separator (11).
2. Disconnect nipple (2) and air eliminator hose (1) from cover (3).

**NOTE**

Assistant will help with step 3.

3. Remove four locknuts (17), screws (12), filter separator (11), and gasket (16) from separator pipe (20) and shelf (13). Discard locknuts (17) and gasket (16).

**b. Disassembly**

1. Remove nut (24), coupling clamp (25), cover (3), and gasket (23) from filter separator (11). Discard gasket (23).
2. Remove cotter pin (27) and vent valve (26) from cover (3). Discard cotter pin (27).
3. Remove six nuts (4), three washers (5), and plate (6) from filter separator (11).
4. Remove three nuts (7), screws (10), and washers (9) from filter separator brackets (8).
5. Remove three canisters (14), filter elements (15) and three fuses (22) from filter separator (11). Discard filter elements (15) and fuses (22).

## 12-41. FILTER SEPARATOR MAINTENANCE (M49A2C) (Contd)

### c. Cleaning and Inspection

#### WARNING

Drycleaning solvent is flammable and will not be used near open flame. Use only in well-ventilated places. Failure to do so may result in injury to personnel.

1. Clean canisters (14) and inside of filter separator (11) with drycleaning solvent.
2. Inspect canisters (14) for cracks. Replace canisters (14) if cracked.

1. Install three new fuses (22), new filter elements (15), and canisters (14) on filter separator (11).
2. Install three screws (10), washers (9), and nuts (7) on filter separator brackets (8).
3. Install plate (6) on filter separator (11) with three washers (5) and six nuts (4).
4. Install valve (26) on cover (3) with new cotter pin (27).
5. Install new gasket (23) and cover (3) on filter separator (11) with coupling clamp (25) and nut (24).

### e. Installation

#### NOTE

Male pipe threads must be wrapped with antiseize tape before installation.

1. Install new gasket (16) on separator pipe (20).
2. Install filter separator (11) on shelf (13) and separator pipe (20) with four screws (12) and new locknuts (17).
3. Install coupling (18) on gasket (16), filter separator (11), and separator pipe (20) with two screws (21) and nuts (19).
4. Connect air eliminator hose (1) and nipple (2) to cover (3).

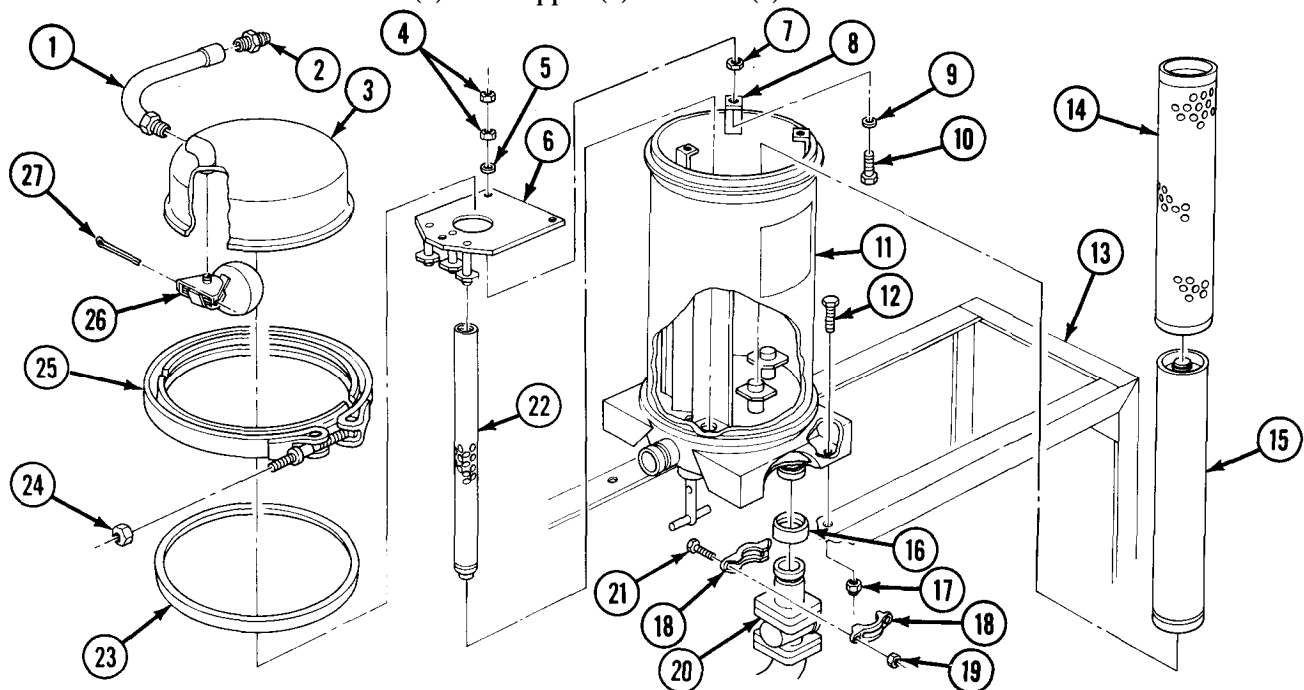

- FOLLOW-ON TASKS:
- Install manhole cover (para. 12-23).
  - Install meter-to-filter tube (para. 12-30).
  - Install filter separator element test valve, gage, and lines (para. 12-40).

**12-42. WATER TANK FILLER COVER REPLACEMENT (M50A2)**

This task covers:

**a. Removal**

**b. Installation**

**INITIAL SETUP:**

APPLICABLE MODELS

M50A2

MATERIALS/PARTS

Four cotter pins  
Gasket

REFERENCES (TM)

TM 9-2320-361-10  
TM 9-2320-361-20P

EQUIPMENT CONDITION

Parking brake set (TM 9-2320-361-10).

**a. Removal**

1. Remove two cotter pins (5) and pin (6) from brace (1) at center of yoke (8). Discard cotter pins (5).
2. Lift handle (4), raise yoke (8), and remove filler cover (10) and gasket (9) from tank body (7). Discard gasket (9). Remove gasket remains from mating surfaces.
3. Remove two cotter pins (2), pin (3), and handle (4) from yoke (8). Discard cotter pins (2).

**b. Installation**

1. Install handle (4) on yoke (8) with pin (3) and two new cotter pins (2).
2. Install new gasket (9) and filler cover (10) on tank body (7).
3. Install brace (1) on yoke (8) with pin (6) and two new cotter pins (5).

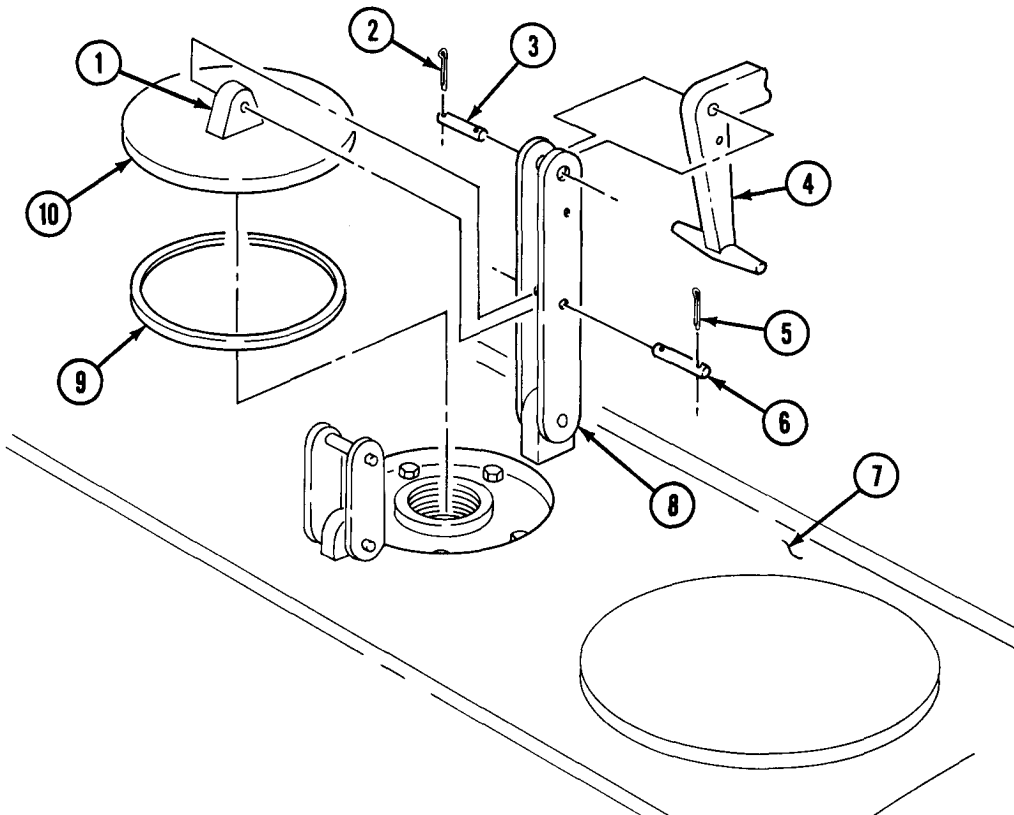

## 12-43. WATER TANK FILLER COVER REPLACEMENT (M50A3)

This task covers:

### a. Removal

### b. Installation

INITIAL SETUP:

#### APPLICABLE MODELS

M50A3

#### REFERENCES (TM)

TM 9-2320-361-10

TM 9-2320-361-20P

#### MATERIALS/PARTS

Gasket

#### EQUIPMENT CONDITION

Parking brake set (TM 9-2320-361-10).

### a. Removal

1. Remove padlock (5) and open clamps (3) on filler cover (1).
2. Remove filler cover (1) and gasket (2) from tank body (4). Discard gasket. Remove gasket remains from mating surfaces.

### b. Installation

1. Install new gasket (2) and filler cover (1) on tank body (4).
2. Close clamps (3) and secure with padlock (5).

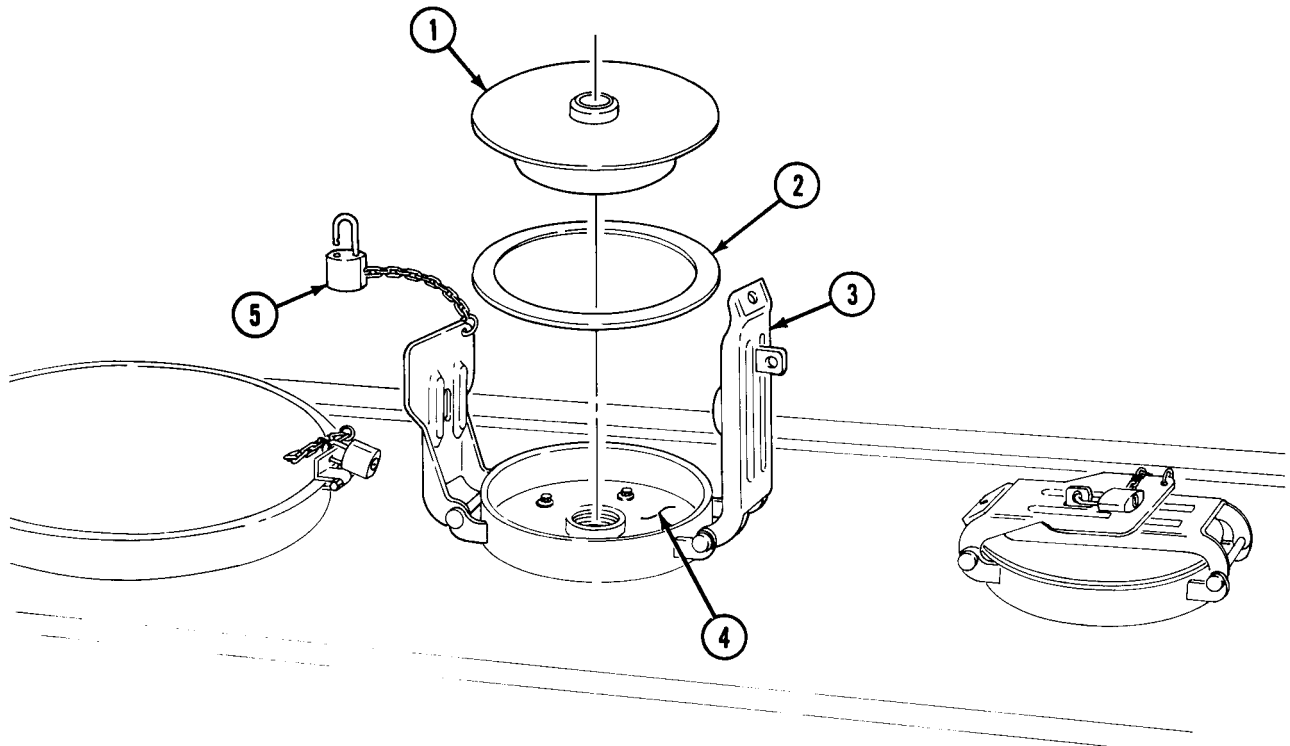



**12-44. REAR COMPARTMENT DOOR MAINTENANCE**

This task covers:

- a. Removal
- b. Cleaning and Inspection

- c. Repair
- d. Installation

**INITIAL SETUP:**

APPLICABLE MODELS

M49A2C, M50A2, M50A3

MATERIALS/PARTS

Twenty-six locknuts

PERSONNEL REQUIRED

Two

REFERENCES (TM)

FM 43-2  
TB 43-0209  
TC 9-510

REFERENCES (TM) (Contd)

TM 9-237  
TM 9-2320-361-10  
TM 9-2320-361-20P  
TM 43-0137

EQUIPMENT CONDITION

Parking brake set (TM 9-2320-361-10).

GENERAL SAFETY INSTRUCTIONS

Keep fire extinguisher nearby when working on fuel tank trucks.

**WARNING**

Do not perform this procedure while smoking or within 50 feet of sparks or open flame. Fuel is flammable and can explode easily, causing injury or death to personnel and damage to equipment.

**a. Removal**

1. Remove six locknuts (8), screws (2), and two holders (1) from compartment doors (4). Discard locknuts (8).

**NOTE**

Assistant will help with step 2.

2. Remove twenty screws (7), locknuts (3), and compartment doors (4) from tank body (9). Discard locknuts (3).
3. Remove four screws (6) and instruction plate (5) from compartment door (4).

**b. Cleaning and Inspection**

1. Refer to para. 2-10 for general cleaning instructions.
2. Inspect compartment door(s) for dents, rust, or damage. Replace compartment door(s) if dented, extensively rusted, or damaged.

**c. Repair**

1. Remove data plates (para. 11-37) or lashing hooks (para. 11-25) in area(s) to be painted/repared.
2. Remove paint or rust from area to be repaired (TM 43-0139).
3. Repair compartment door(s) (TM 9-237 and TC 9-510).
4. Paint compartment door(s) as required (TM 43-0137 and TB 43-0209).
5. Install data plates (para. 11-37) or lashing hooks (para. 11-37).

**d. Installation**

1. Install instruction plate (5) on compartment door (4) with four screws (6).

**NOTE**

Assistant will help with step 2.

2. Install compartment doors (4) on tank body (9) with twenty screws (7) and new locknuts (3).
3. Install two door holders (1) on compartment doors (4) with six screws (2) and new locknuts (8).

12-44. REAR COMPARTMENT DOOR MAINTENANCE (Contd)

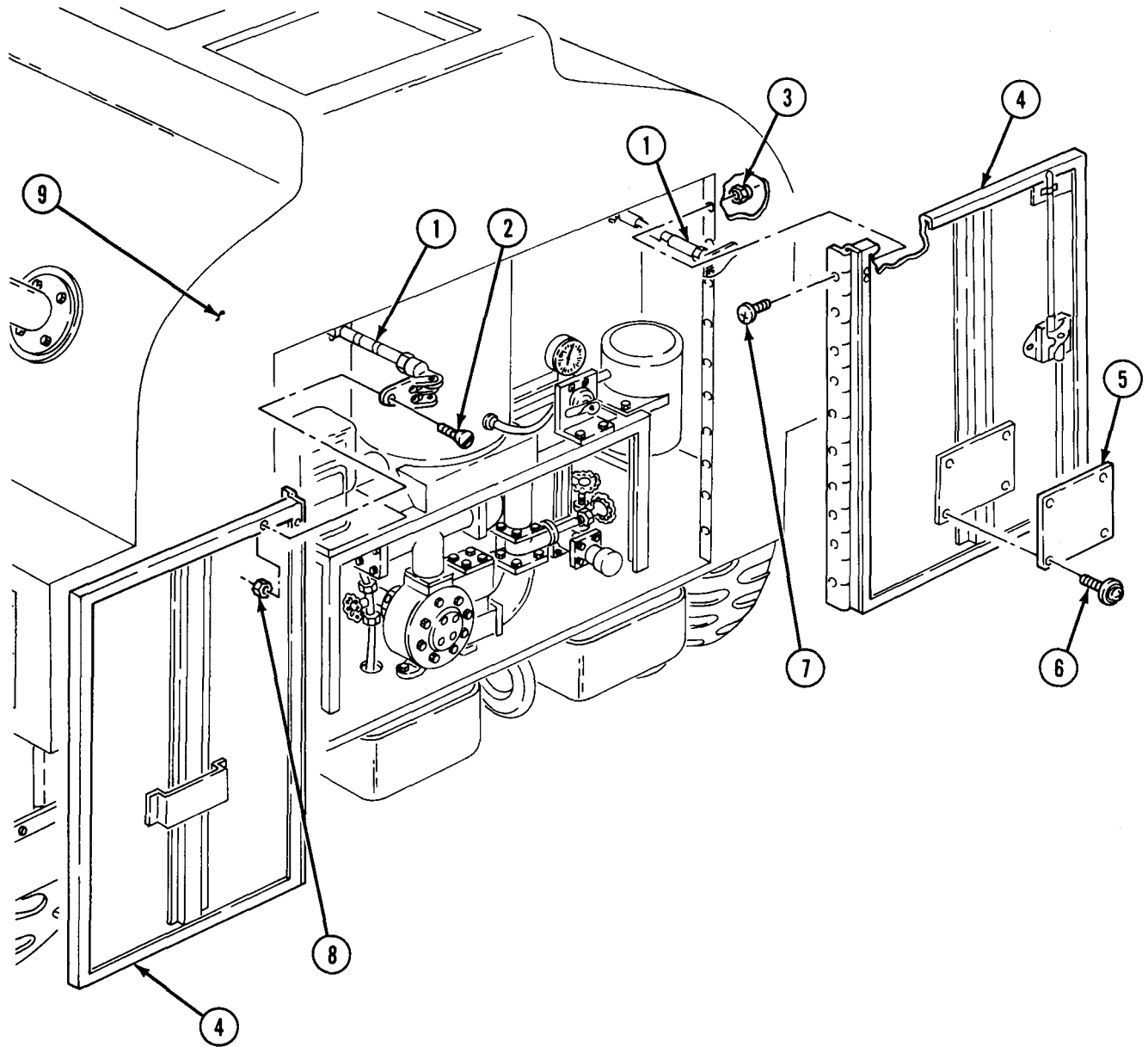

## 12-45. WATER TANK DISCHARGE TUBE AND VALVE REPLACEMENT (M50A2)

This task covers:

- a. Discharge Tube Removal
- b. Discharge Valve Removal

- c. Discharge Valve Installation
- d. Discharge Tube Installation

### INITIAL SETUP:

#### APPLICABLE MODELS

M50A2

#### MATERIALS/PARTS

Four gaskets  
Eighteen locknuts

#### REFERENCES (TM)

TM 9-2320-361-10  
TM 9-2320-361-20P

#### EQUIPMENT CONDITION

- Parking brake set (TM 9-2320-361-10).
- Water tanks drained (TM 9-2320-361-10).

#### GENERAL SAFETY INSTRUCTIONS

Wear gloves when handling cable.

### WARNING

Wear leather gloves when handling cable. Do not let cable run through hands. Broken or rusty wires can cause injury to personnel.

#### **a. Discharge Tube Removal**

1. Remove two nuts (5), screws (4), and coupling (3). Slide gasket (2) back on tube (11).
2. Remove twelve locknuts (14), screws (9), tube (11), gasket (2), and two gaskets (6) from two discharge valves (15). Discard gaskets (2) and (6) and locknuts (14).

#### **b. Discharge Valve Removal**

### **NOTE**

Both discharge valves are removed and installed the same way.

1. Remove nut (7) from clip (8) and remove cable (12) and thimble (10) from lever (13).
2. Remove six locknuts (17), discharge valve (15), and gasket (16) from bottom of tank (1). Discard locknuts (17) and gasket (16).

#### **c. Discharge Valve Installation**

1. Install new gasket (16) and discharge valve (15) on bottom of tank (1) with six new locknuts (17).
2. Install cable (12) and thimble (10) on lever (13) with clip (8) and nut (7).

#### **d. Discharge Tube Installation**

1. Install new gasket (2) on tube (11).
2. Install two new gaskets (6) and tube (11) on two discharge valves (15) with twelve screws (9) and new locknuts (14).
3. Slide gasket (2) to end of tube (11) and install coupling (3) with two screws (4) and nuts (5).

**12-45. WATER TANK DISCHARGE TUBE AND VALVE REPLACEMENT (M50A2) (Contd)**

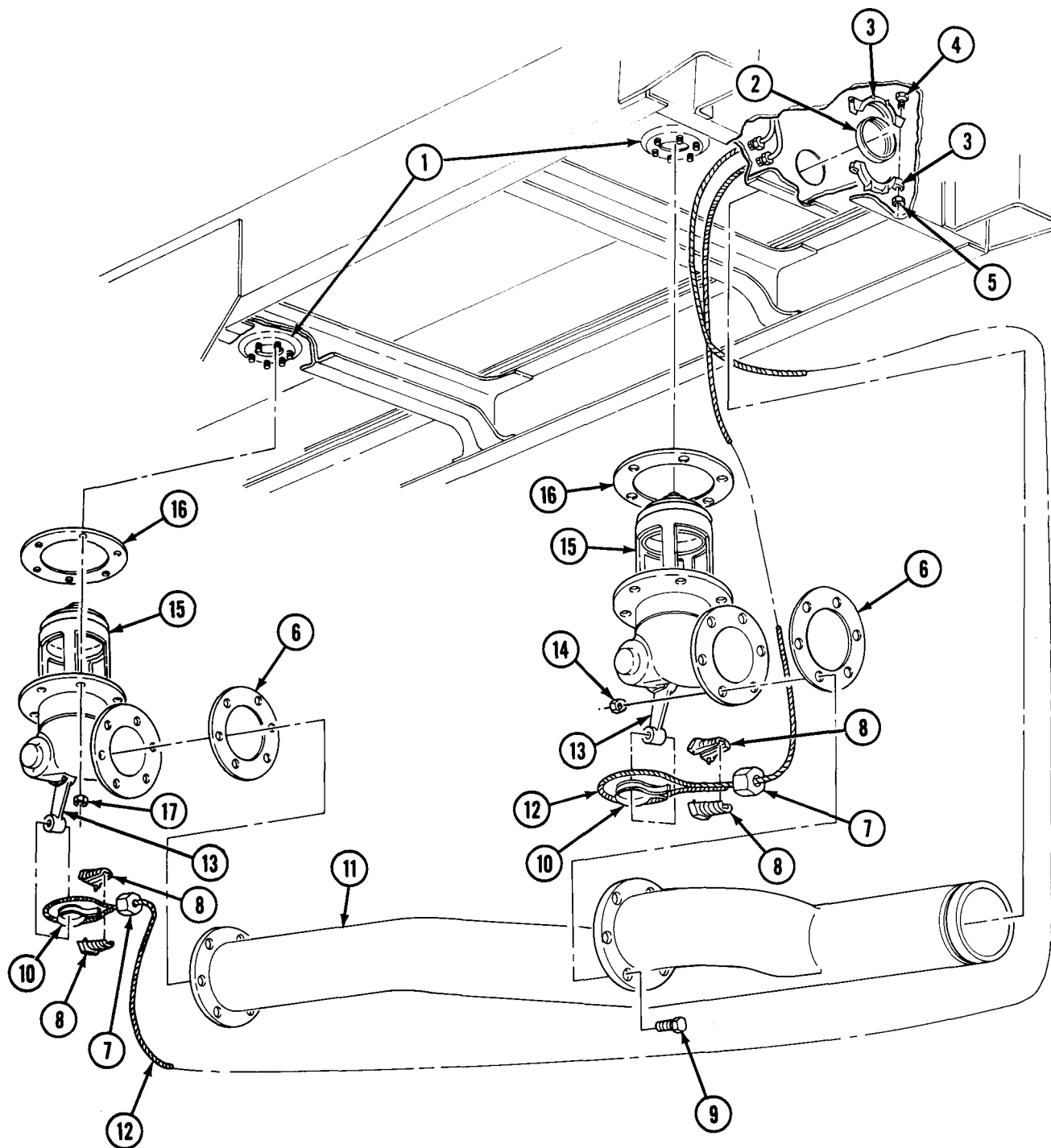

FOLLOW-ON TASK: Fill water tanks (TM 9-2320-361-10) and check for leaks.

**12-46. WATER TANK DISCHARGE TUBE AND VALVE REPLACEMENT (M50A3)**

This task covers:

- a. Discharge Tube Cover Removal
- b. Discharge Tube Removal
- c. Discharge Valves Removal

- d. Discharge Valves Installation
- e. Discharge Tube Installation
- f. Discharge Tube Cover Installation

**INITIAL SETUP:**

**APPLICABLE MODELS**

M50A3

**MATERIALS/PARTS**

Five gaskets  
Ten locknuts

**REFERENCES (TM)**

TM 9-2320-361-10

TM 9-2320-361-20P

**EQUIPMENT CONDITION**

- Parking brake set (TM 9-2320-361-10).
- Water tanks drained (TM 9-2320-361-10).

**a. Discharge Tube Cover Removal**

1. Remove fifty-two screws (3) from discharge tube cover (2).
2. Slide discharge tube cover (2) left to access discharge valves (9) and discharge tube (19).

**b. Discharge Tube Removal**

1. Remove four locknuts (11), two holders (10), U-bolts (12), and cables (13) and (22) from two discharge valves (9). Discard locknuts (11).
2. Remove two cables (13) and (22) from two guides (14) and (20).
3. Remove two nuts (7), screws (6), coupling (5) and gasket (4) from discharge tube (19). Discard gasket (4).
4. Remove four nuts (15), guides (14) and (20), four screws (18), two couplings (17), two gaskets (16), and discharge tube (19) from two discharge valves (9). Discard gaskets (16).

**c. Discharge Valves Removal**

**NOTE**

Both discharge valves are replaced the same way.

Remove six locknuts (21), discharge valve (9), and gasket (8) from bottom of tank (1). Discard gasket (8) and locknuts (21).

**d. Discharge Valves Installation**

Install new gasket (8) and discharge valve (9) on bottom of tank (1) with six new locknuts (21).

**e. Discharge Tube Installation**

1. Install discharge tube (19) on two discharge valves (9) with two new gaskets (16), two couplings (17), four screws (18), and four nuts (15).
2. Install new gasket (4) and coupling (5) on discharge tube (19) with two screws (6) and nuts (7).
3. Install two cables (13) and (22) through guides (14) and (20).
4. Install two cables (13) and (22) on two discharge valves (9) with two U-bolts (12), holders (10), and four new locknuts (11).

**12-46. WATER TANK DISCHARGE TUBE AND VALVE REPLACEMENT (M50A3) (Contd)**

**f. Discharge Tube Cover Installation**

1. Slide discharge tube cover (2) right and cover discharge tube (19) and valves (9).
2. Install cover (2) with fifty-two screws (3).

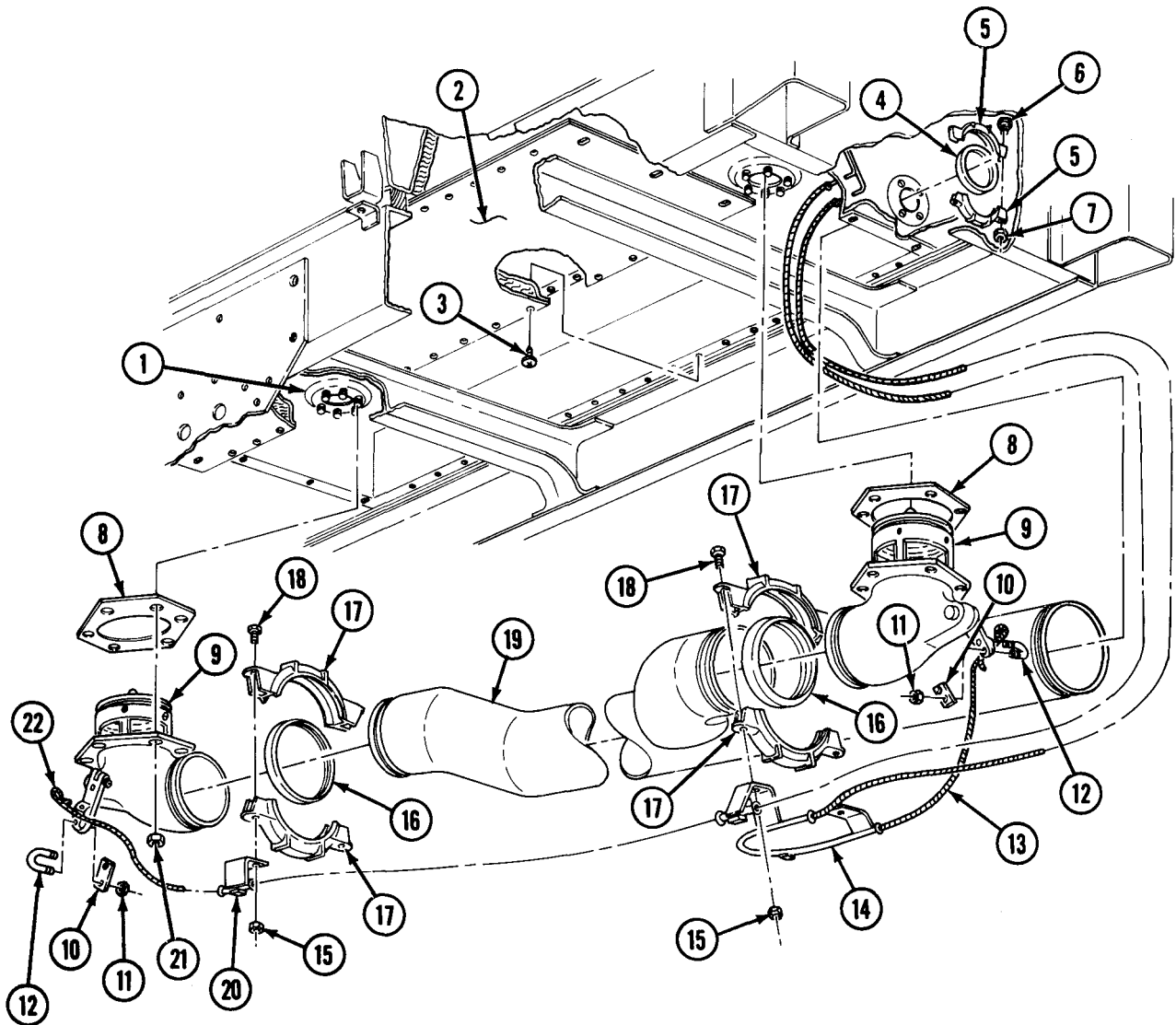

FOLLOW-ON TASK: Fill water tanks (TM 9-2320-361-10) and check for leaks.

**12-47. WATER TANK DISCHARGE VALVE CONTROL LEVERS MAINTENANCE  
(M50A2, M50A3)**

This task covers:

- |  |   |
|--|---|
| <p><b>a. Removal</b><br/> <b>b. Disassembly</b><br/> <b>c. Cleaning and Inspection</b></p> | <p><b>d. Assembly</b><br/> <b>e. Installation</b><br/> <b>f. Adjustment</b></p> |
|--|---|

**INITIAL SETUP:**

APPLICABLE MODELS

M50A2, M50A3

MATERIALS/PARTS

Six locknuts  
 Six lockwashers

REFERENCES (TM)

TM 9-2320-361-10  
 TM 9-2320-361-20P

EQUIPMENT CONDITION

Parking brake set (TM 9-2320-361-10).

GENERAL SAFETY INSTRUCTIONS

Wear gloves when handling cable.

**WARNING**

Wear leather gloves when handling cable. Do not let cable run through hands. Broken or rusty wires can cause injury to personnel.

**a. Removal**

1. Unscrew two coupling nuts (5) from adapters (6) and slide back on tubes (4).
2. Unscrew two adapters (6) from spacer bar (8).
3. Remove two nuts (11) and screws (9) from discharge valve control levers (10), and pull cables (7) out of screws (9), space bar (8), and two adapters (6).
4. Remove six locknuts (12), screws (1), and discharge valve control assembly (3) from shelf (2). Discard locknuts (12).

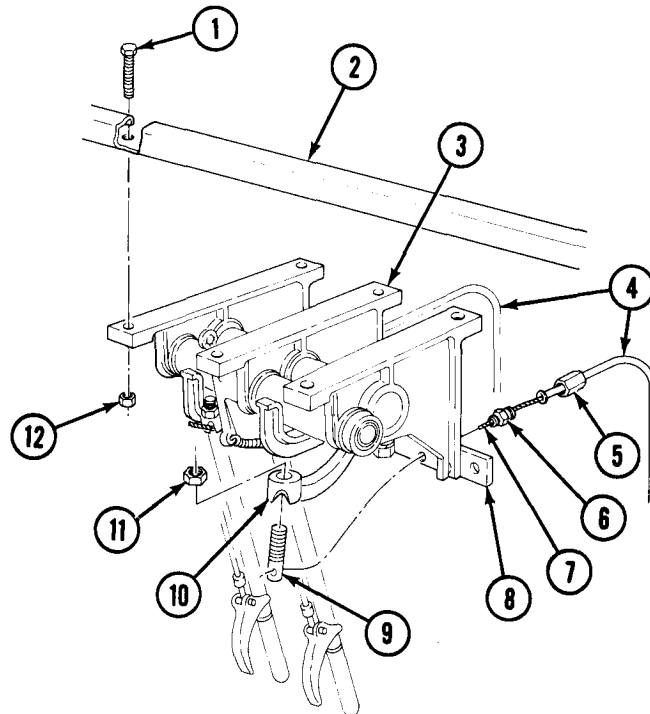

## 12-47. WATER TANK DISCHARGE VALVE CONTROL LEVERS MAINTENANCE (M50A2, M50A3) (Contd)

### b. Disassembly

#### CAUTION

Do not strike levers or brackets during lever shaft removal. Striking levers or brackets may result in damage to components.

1. Remove three screws (17) and lockwashers (18) from brackets (16), (27), and (25). Discard lockwashers (18).

#### NOTE

All components should be tagged for location during assembly.

2. Remove lever shaft (19) from bracket (25), lever (26), bracket (27), lever (15), and bracket (16). Remove levers (15) and (26).
3. Remove three screws (13), lockwashers (14), and spacer bar (8) from brackets (16), (27), and (25). Discard lockwashers (14).
4. Remove spacers (21) and (23) from bushings (20), (22), and (24).

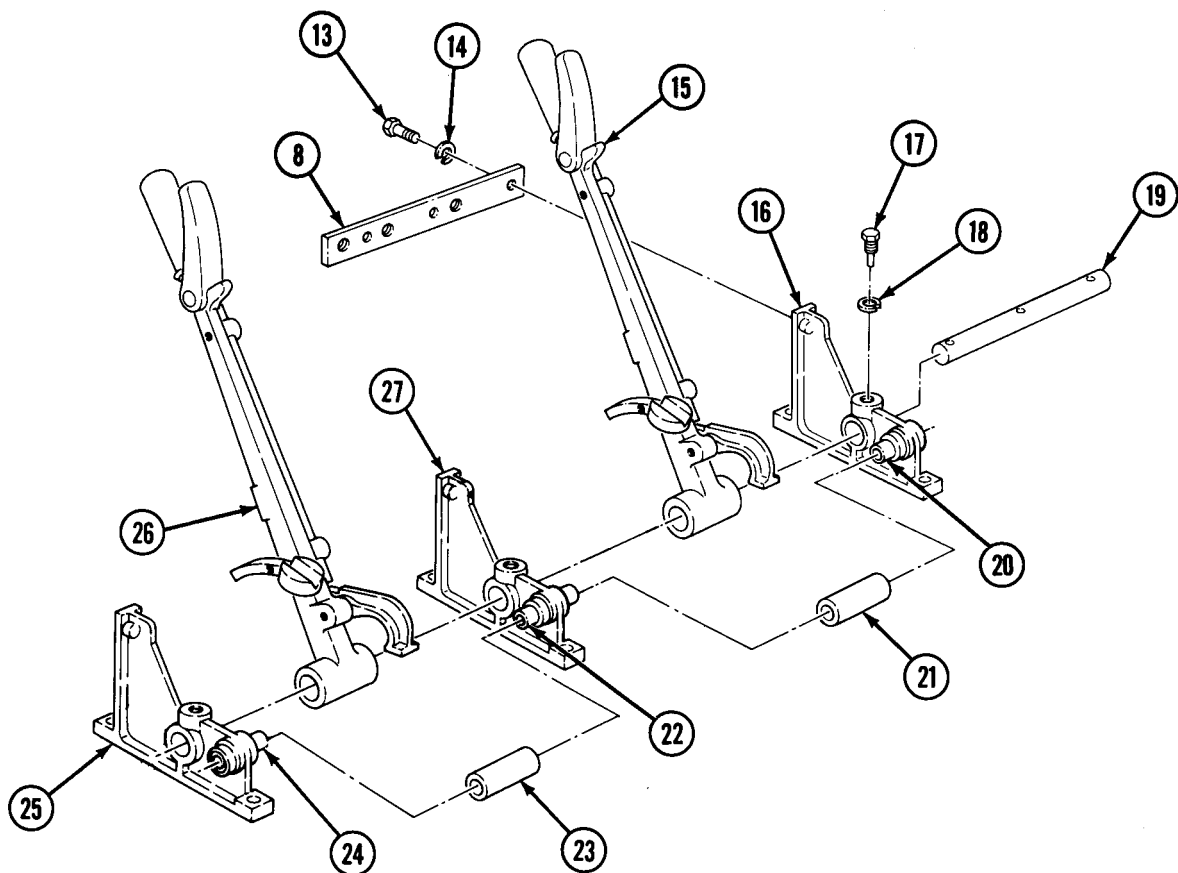



**12-47. WATER TANK DISCHARGE VALVE CONTROL LEVERS MAINTENANCE  
(M50A2, M50A3) (Contd)**

**c. Cleaning and Inspection**

1. Refer to para. 2-10 for general cleaning instructions.
2. Refer to para. 2-10 for general inspection instructions.
3. Refer to table below for lever assembly area limits.

*Table 12-2. M50A2, M50A3 Water Tank Discharge Valve Control Levers Wear Limits.*

ITEM NO.	ITEM/POINT OF MEASUREMENT	WEAR LIMITS/TOLERANCES	
		INCHES	MILLIMETERS
7	Lever shaft (diameter)	0.860-0.885 in.	21.84-22.48 mm
3 and 14	Levers (inner diameter at shaft hole)	0.868-0.922 in.	22.05-23.42 mm
8, 10, and 12	Bushings (outer diameter)	0.436-0.438 in.	11.07-11.13 mm
9 and 11	Spacers (inner diameter)	0.440-0.444 in.	11.18-11.28 mm
9 and 11	Spacers (outer diameter)	0.720-0.780 in.	18.29-19.81 mm

4. Inspect spacers (9) and (11) for flat spots or wear. Refer to table 12-2, M50A2, M50A3 Water Tank Discharge Valve Control Levers Wear Limits, for measurements. Replace spacers (9) and (11) if not within wear limits.
5. Inspect bushings (8), (10), and (12) for grooves or wear. Refer to table 12-2, M50A2, M50A3 Water Tank Discharge Valve Control Levers Wear Limits, for measurements. Replace bushings (8), (10), and (12) if not within wear limits.
6. Inspect brackets (4), (15), and (13) for cracks or damage. Replace brackets (4), (15), and (13) if cracked or damaged.

**NOTE**

Perform steps 7 through 9 if bushings or brackets are damaged or not within wear limits.

7. Press bushings (8), (10), and (12) from brackets (4), (15), and (13). Discard bushings (8), (10), and (12).
8. Install new bushings (8) and (12) in brackets (4) and (13) with press until bushings (8) and (12) ends are flush with brackets (4) and (13).
9. Install new bushings (10) in bracket (15) with press until bushing (10) ends extend .5 in. (12.7 mm) from bracket (15) sides.
10. Inspect levers (3) and (14) for wear, latch, handle, or rod damage. Refer to table 12-2, M50A2, M50A3 Water Tank Discharge Valve Control Levers Wear Limits, for measurements. Replace levers (3) and (14) if not within wear limits.
11. Inspect lever shaft (7) for grooves or wear. Refer to table 12-2, M50A2, M50A3 Water Tank Discharge Valve Control Levers Wear Limits, for measurements. Replace lever shaft (7) if not within wear limits.
12. Inspect spacer bar (16) for cracks or damage. Replace spacer bar (16) if cracked or damaged.

**d. Assembly**

1. Place spacers (9) and (11) on exposed ends of bushings (8), (10), and (12).
2. Install spacer bar (16) on brackets (4), (15), and (13) with three new lockwashers (2) and screws (1). Do not tighten screws (1).
3. Place lever shaft (7) through bracket (4), lever (3), bracket (15), lever (14), and bracket (13), and install with three new lockwashers (6) and screws (5).
4. Tighten three screws (1).

**12-47. WATER TANK DISCHARGE VALVE CONTROL LEVERS MAINTENANCE  
(M50A2, M50A3) ( Contd)**

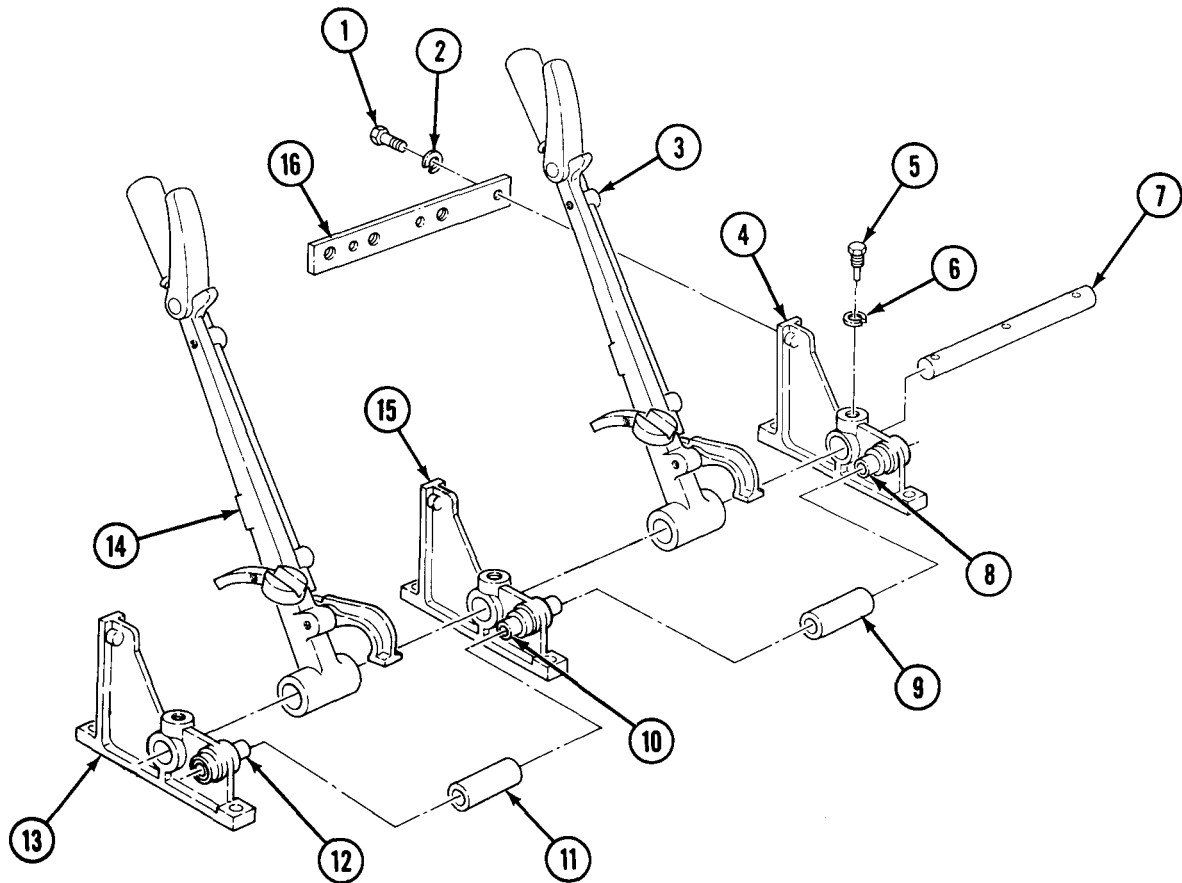

**12-47. WATER TANK DISCHARGE VALVE CONTROL LEVERS MAINTENANCE  
(M50A2, M50A3) (Contd)**

**e. Installation**

1. Install two cables (6) through adapters (5) and plate (7).
2. Install discharge valve control assembly (3) under shelf (2) with six screws (1) and new locknuts (11).
3. Install two adapters (5) to plate (7).
4. Insert two screws (8) in two valve control levers (9) and install nuts (10). Do not tighten nuts (10).
5. Thread cables (6) through holes in screws (8).
6. Install two coupling nuts (4) on adapters (5).
7. Remove slack in two cables (6) and tighten nuts (10).

**f. Adjustment**

**NOTE**

Hold end of cable securely before loosening nuts. Cable may be under tension.

1. Loosen two nuts (10).
2. Remove slack in two cables (6) and tighten nuts (10).

**12-47. WATER TANK DISCHARGE VALVE CONTROL LEVERS MAINTENANCE  
(M50A2, M50A3) (Contd)**

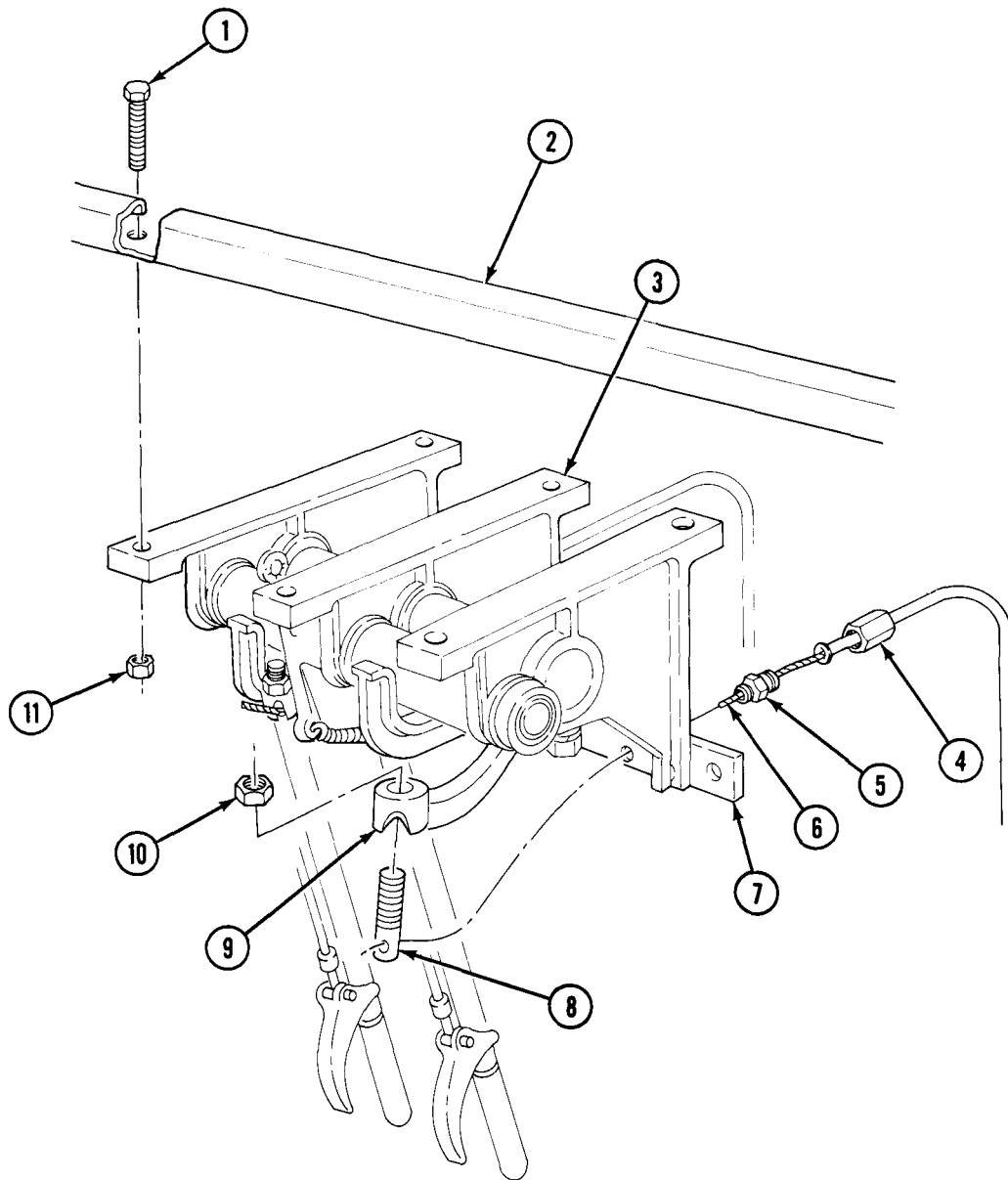

<b>12-48. WATER TANK MANHOLE COVER REPLACEMENT (M50A2)</b>
--

This task covers:

**a. Removal**

**b. Installation**

**INITIAL SETUP:**

APPLICABLE MODELS

M50A2

MATERIALS/PARTS

Twelve cotter pins

Two gaskets

REFERENCES (TM)

TM 9-2320-361-10

TM 9-2320-361-20P

EQUIPMENT CONDITION

Parking brake set (TM 9-2320-361-10).

<b>a. Removal</b>
-------------------

1. Remove two cotter pins (6) and pin (7) from center brace (10) and yoke (5). Discard cotter pins (6).
2. Raise yoke (5) and remove cover (1) and gasket (9) from tank body (8). Discard gasket (9).
3. Remove two cotter pins (2), pin (3), and handle (4) from yoke (5). Discard cotter pins (2).
4. Remove eight cotter pins (14), four pins (15), two eyebolts (12), nut (13), and yoke (11) from center brace (16) and two supports (17). Discard cotter pins (14).
5. Remove cover (20) and gasket (19) from interior of manhole (18). Discard gasket (19).

<b>b. Installation</b>
------------------------

1. Install new gasket (19) and cover (20) in manhole (18).
2. Install yoke (11) on center brace (16) and two supports (17) with eight new cotter pins (14), four pins (15), two bolts (12), and nut (13).
3. Install handle (4) on yoke (5) with pin (3) and two new cotter pins (2).
4. Install new gasket (9) and cover (1) on tank body (8).
5. Install yoke (5) on center brace (10) with pin (7) and two new cotter pins (6).

12-48. WATER TANK MANHOLE COVER REPLACEMENT (M50A2) (Contd)

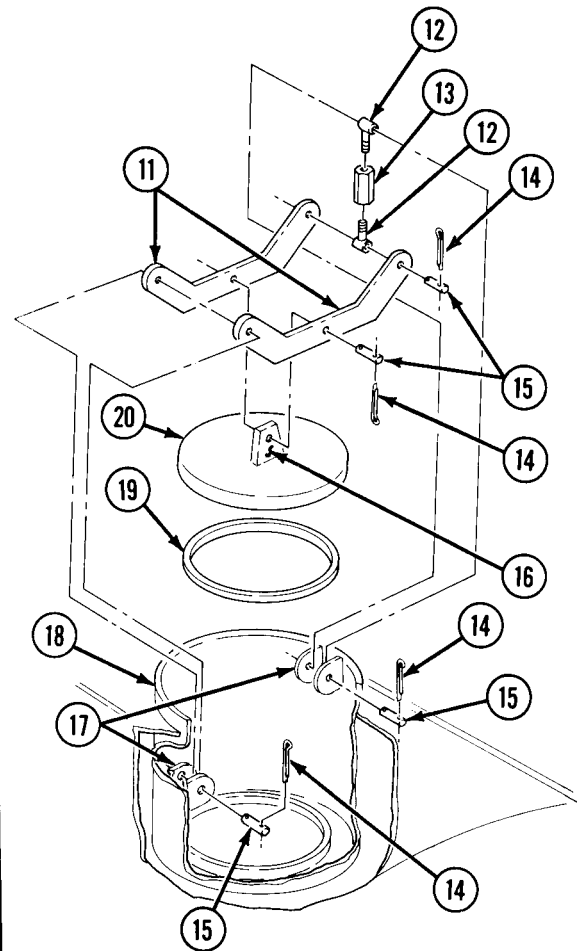
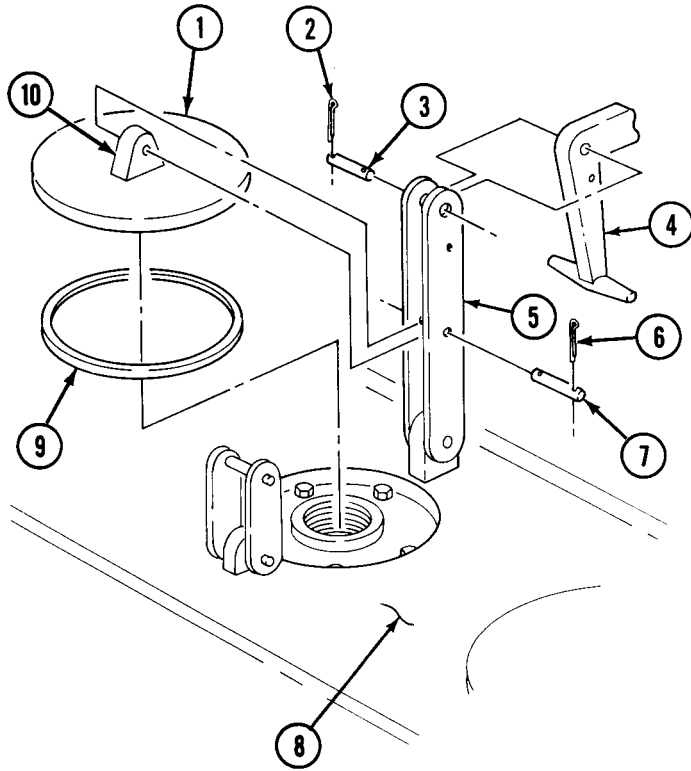

**12-49. WATER TANK MANHOLE COVER REPLACEMENT (M50A3)**

This task covers:

**a. Removal**

**b. Installation**

INITIAL SETUP:

APPLICABLE MODELS

M50A3

REFERENCES (TM)

TM 9-2320-361-10

TM 9-2320-361-20P

MATERIALS/PARTS

Gasket

EQUIPMENT CONDITION

Parking brake set (TM 9-2320-361-10).

**a. Removal**

1. Remove padlock (2) and clamping ring (1) from manhole cover (5) and tank body (3).
2. Remove manhole cover (5) and gasket (4). Discard gasket (4).

**b. Installation**

1. Install new gasket (4) on cover (5). Install cover (5) on tank body (3).
2. Place clamping ring (1) around manhole cover (5) and tank body (3). Install padlock (2) on cover (5).

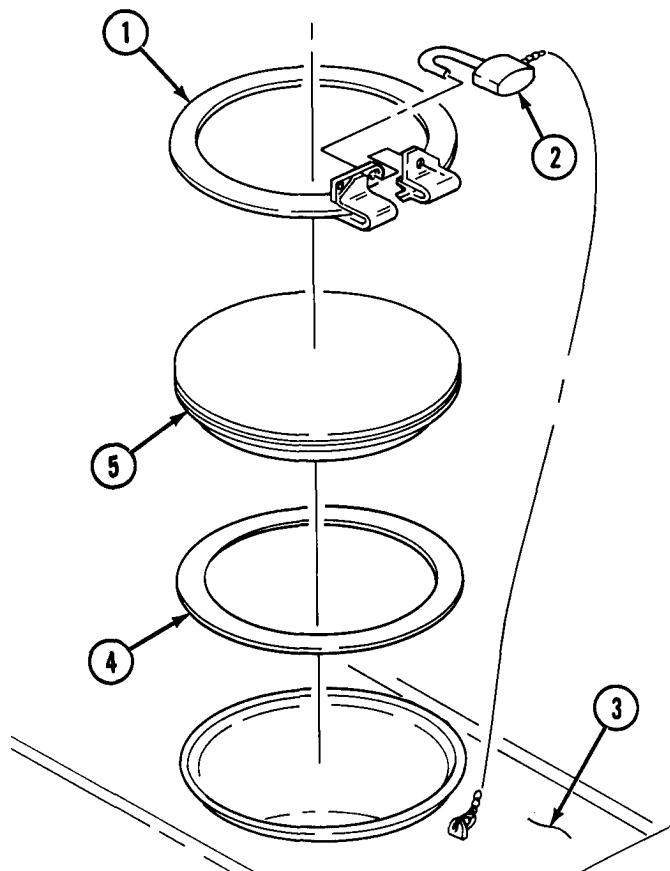

## 12-50. DELIVERY PUMP FRONT PROPELLER SHAFT MAINTENANCE (M50A2)

This task covers:

- a. Removal
- b. Inspection

c. Installation

INITIAL SETUP:

### APPLICABLE MODELS

M50A2

### MATERIALS/PARTS

Four locknuts

Key

### REFERENCES (TM)

TM 9-2320-361-10

TM 9-2320-361-20P

### EQUIPMENT CONDITION

Parking brake set (TM 9-2320-361-10).

### a. Removal

1. Remove four locknuts (1), screws (3), and delivery pump front shaft (4) from power takeoff flange (2). Discard locknuts (1).
2. Remove setscrew (7) and delivery pump front propeller shaft (4) from delivery pump rear propeller shaft (6).
3. Remove key (5) from delivery pump rear propeller shaft (6). Discard key (5).

### b. Inspection

Inspect U-joints (8) for wear or damage. Replace U-joints (8) if worn or damaged (para. 7-4).

### c. Installation

1. Install new key (5) on delivery pump rear propeller shaft (6).
2. Install delivery pump front propeller shaft (4) on delivery pump rear propeller shaft (6) with setscrew (7).
3. Install delivery pump front propeller shaft (4) on power takeoff flange (2) with four screws (3) and new locknuts (11)

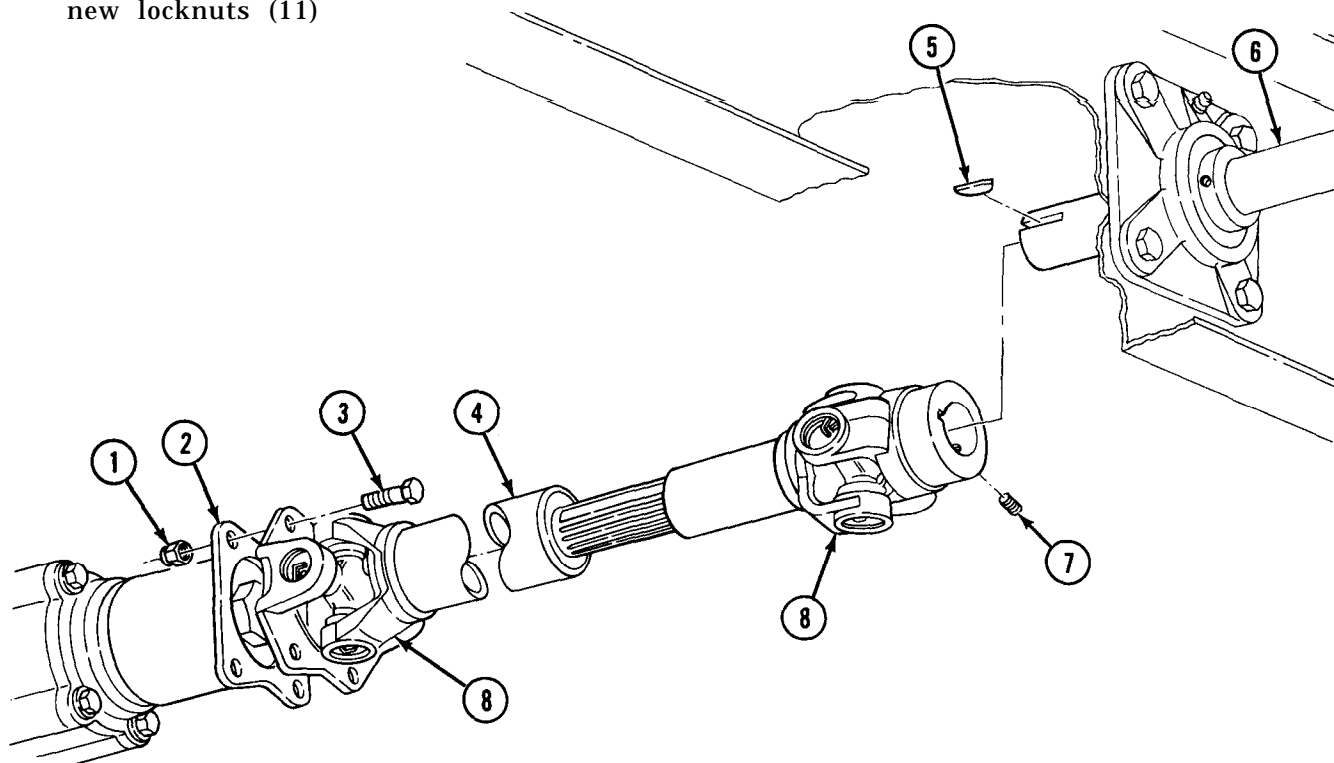



**12-51. DELIVERY PUMP FRONT PROPELLER SHAFT MAINTENANCE (M49A2C, M50A3)**

This task covers:

- a. Removal
- b. Inspection

c. Installation

**INITIAL SETUP:**

APPLICABLE MODELS

M49A2C, M50A3

MATERIALS/PARTS

Four locknuts  
Key

REFERENCES (TM)

TM 9-2320-361-10  
TM 9-2320-361-20P

EQUIPMENT CONDITION

- Parking brake set (TM 9-2320-361-10).
- Discharge tube cover removed (M50A3 only) (para. 12-46).

GENERAL SAFETY INSTRUCTIONS

Keep fire extinguisher nearby when working on fuel tank trucks.

**WARNING**

Do not perform this procedure while smoking or within 50 feet of sparks or open flame. Fuel is flammable and can explode easily, causing injury or death to personnel and damage to equipment.

**a. Removal**

1. Remove four screws (3) and locknuts (1) from power takeoff flange (2) and delivery pump front propeller shaft (4). Discard locknuts (1).
2. Remove setscrew (7) and delivery pump front propeller shaft (4) from intermediate shaft (6).
3. Remove key (5) from intermediate shaft (6). Discard key (5).

**b. Inspection**

Inspect U-joints (8) for wear or damage. Replace U-joints (8) if worn or damaged (para. 7-4).

**c. Installation**

1. Install new key (5) in intermediate shaft (6).
2. Install delivery pump front propeller shaft (4) on intermediate shaft (6) with setscrew (7).
3. Install delivery pump front propeller shaft (4) on power takeoff flange (2) with four screws (3) and new locknuts (1).

**12-51. DELIVERY PUMP FRONT PROPELLER SHAFT MAINTENANCE (M49A2C, M50A3)  
(Contd)**

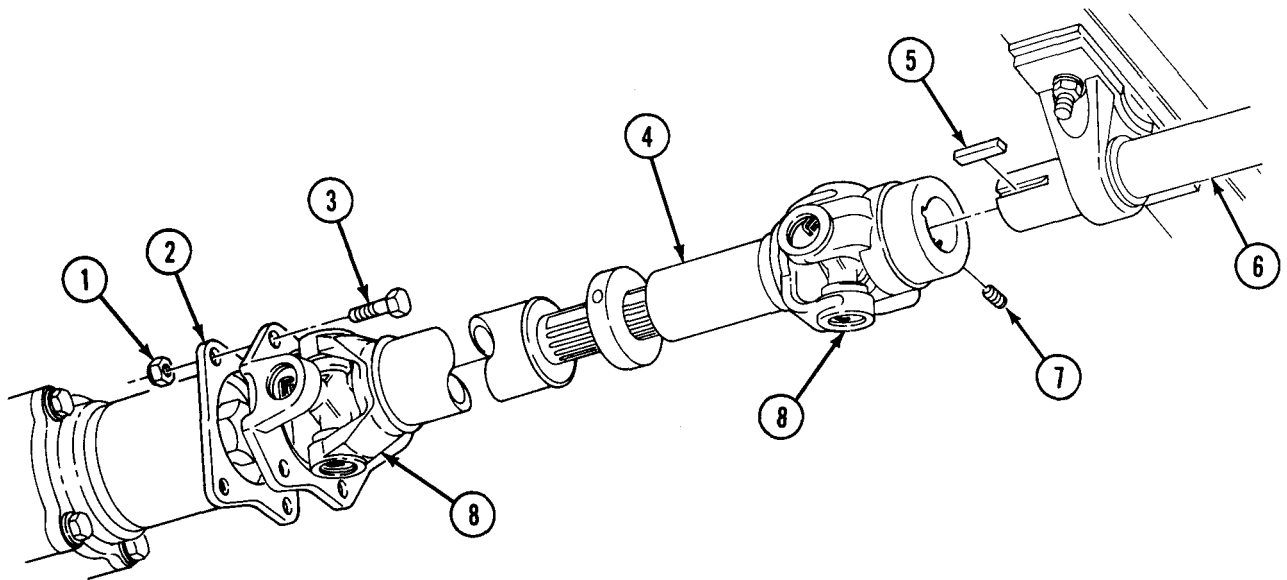

FOLLOW-ON TASK: Install discharge tube cover (para. 12-46).

**12-52. DELIVERY PUMP REAR PROPELLER SHAFT MAINTENANCE (M50A2)**

This task covers:

- a. Removal
- b. Inspection

c. Installation

**INITIAL SETUP:**

APPLICABLE MODELS

M50A2

MATERIALS/PARTS

Eight locknuts  
Key

REFERENCES (TM)

TM 9-2320-361-10  
TM 9-2320-361-20P

EQUIPMENT CONDITION

- Parking brake set (TM 9-2320-361-10).
- Delivery pump front propeller shaft removed (para. 12-50).

**a. Removal**

1. Remove clip (10), keeper (9), master link (8), and chain (11). Loosen two setscrews (5).
2. Slide delivery pump rear propeller shaft (2) forward and remove sprockets (6) from delivery pump shaft (7).
3. Remove delivery pump rear propeller shaft (2) from bearing flanges (4).
4. Remove key (3) from delivery pump rear propeller shaft (2). Discard key (3).
5. Remove eight locknuts (12), screws (13), and two bearing flanges (4) from frame (1). Discard locknuts (12).

**b. Inspection**

1. Inspect delivery pump rear propeller shaft (2), bearing flanges (4), sprocket (6), and chain (11) for cracks, bends, and excessive wear. Replace components that are cracked, bent, or excessively worn.
2. Inspect U-joint for wear or damage. Replace U-joints if worn or damaged (para. 7-4).

**c. Installation**

1. Install two bearing flanges (4) on frame (1) with eight screws (13) and new locknuts (12).
2. Install new key (3) in delivery pump rear propeller shaft (2).
3. Install delivery pump rear propeller shaft (2) through bearing flanges (4).
4. Install two sprockets (6) on delivery pump shaft (7).
5. Install delivery pump rear propeller shaft (2) through sprockets (6) and tighten two setscrews (5).
6. Install chain (11) on sprockets (6) with master link (8), keeper (9), and clip (10).

12-52. DELIVERY PUMP REAR PROPELLER SHAFT MAINTENANCE (M50A2) (Contd)

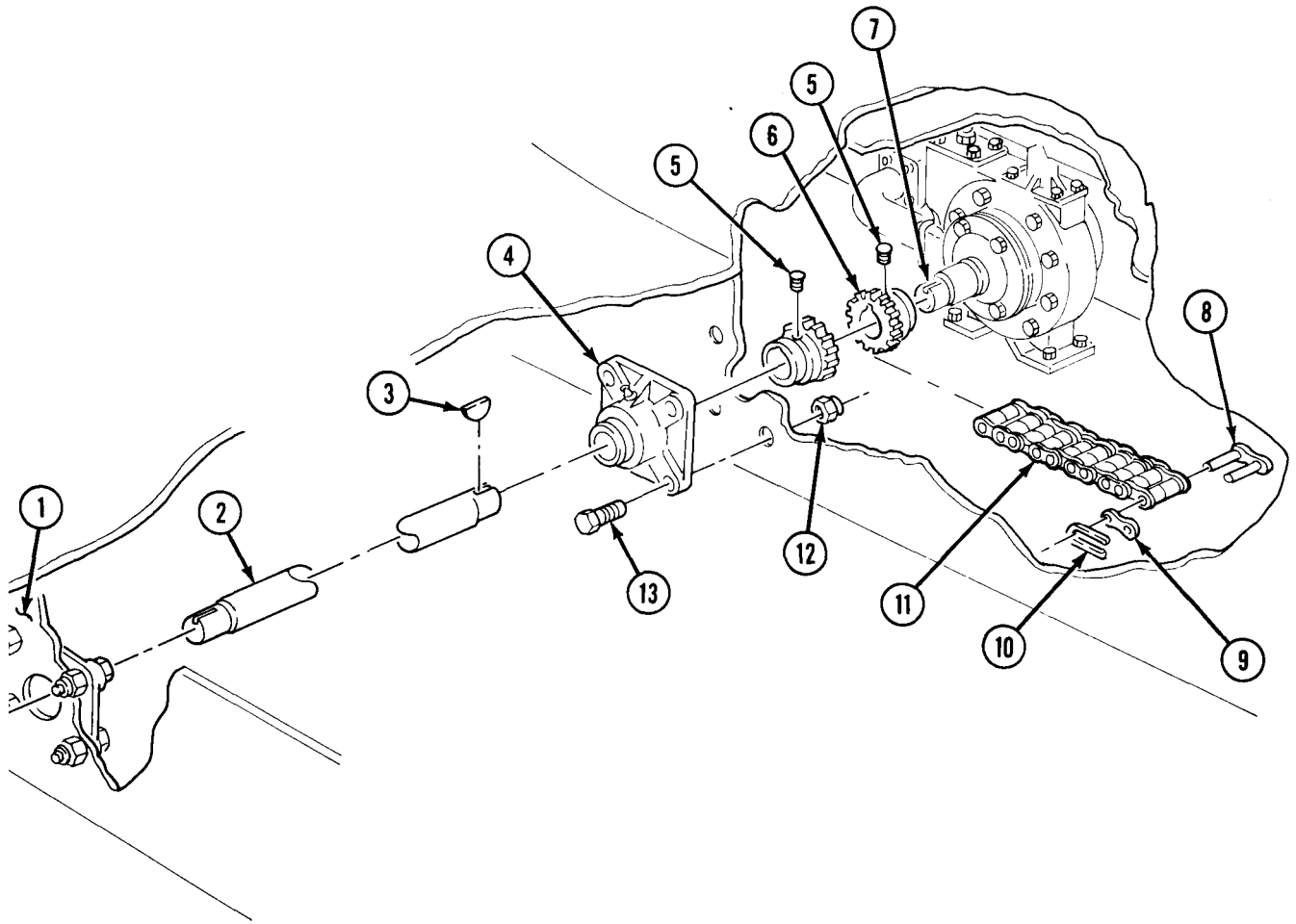

FOLLOW-ON TASK: Install delivery pump front propeller shaft (para. 12-50).

**12-53. DELIVERY PUMP REAR PROPELLER SHAFT MAINTENANCE (M49A2C, M50A3)**

This task covers:

- a. Removal
- b. Inspection

c. Installation

**INITIAL SETUP:**

**APPLICABLE MODELS**

M49A2C, M50A3

**MATERIALS/PARTS**

Two keys

**REFERENCES (TM)**

TM 9-2320-361-10

TM 9-2320-361-20P

**EQUIPMENT CONDITION**

- Parking brake set (TM 9-2320-361-10).
- Discharge tube cover removed (M50A3 only) (para. 12-46).
- Delivery pump front propeller shaft removed (para. 12-51).

**GENERAL SAFETY INSTRUCTIONS**

Keep fire extinguisher nearby when working on fuel tank trucks

**WARNING**

Do not perform this procedure while smoking or within 50 feet of sparks or open flame. Fuel is flammable and can explode easily, causing injury or death to personnel and damage to equipment.

**a. Removal**

1. Remove setscrew (5) and intermediate shaft (6) from delivery pump rear propeller shaft (8).
2. Remove key (7) from intermediate shaft (6). Discard key (7).
3. Remove setscrew (3) and delivery pump rear propeller shaft (8) from delivery pump shaft (2).
4. Remove key (1) from delivery pump shaft (2). Discard key (1).

**b. Inspection**

Inspect U-joints (4) for wear or damage. Replace U-joints (4) if worn or damaged (para. 7-4).

**c. Installation**

1. Install new key (1) in delivery pump shaft (2).
2. Install delivery pump rear propeller shaft (8) on delivery pump shaft (2) with setscrew (3).
3. Install new key (7) in intermediate shaft (6).
4. Install intermediate shaft (6) on delivery pump rear propeller shaft (8) with setscrew (5).

**12-53. DELIVERY PUMP REAR PROPELLER SHAFT MAINTENANCE (M49A2C, M50A3) (Contd)**

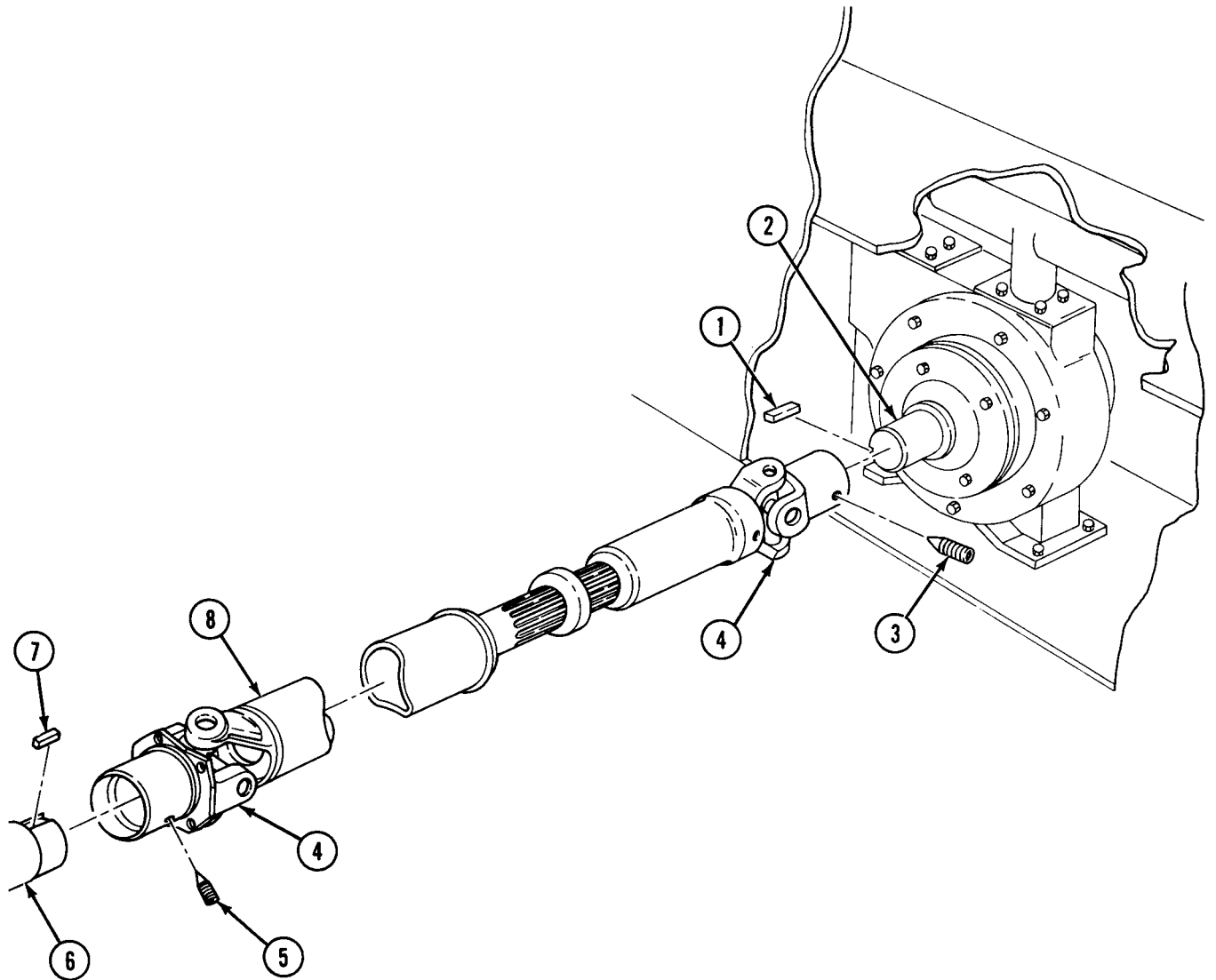

**FOLLOW-ON TASKS:**

- Install delivery pump front propeller shaft (para. 12-51).
- Install discharge tube cover (para. 12-46).

**12-54. SPEED CONTROL CABLE MAINTENANCE**

This task covers:

- a. Removal
- b. Inspection

- c. Installation
- d. Adjustment

**INITIAL SETUP:**

APPLICABLE MODELS

M49A2C, M50A2, M50A3

TOOLS AND TEST EQUIPMENT

STE/ICE

MATERIALS/PARTS

Two cotter pins  
Two lockwashers

REFERENCES (TM)

TM 9-2320-361-10  
TM 9-2320-361-20P

EQUIPMENT CONDITION

Parking brake set (TM 9-2320-361-10).

GENERAL SAFETY INSTRUCTIONS

Keep fire extinguisher nearby when working on fuel tank trucks.

**WARNING**

Do not perform this procedure while smoking or within 50 feet of sparks or open flame. Fuel is flammable and can explode easily, causing injury or death to personnel and damage to equipment.

**a. Removal**

1. Remove cotter pin (16) and pin (17) from eye (18) and fuel pump lever (2). Discard cotter pin (16).
2. Loosen two nuts (14) and remove cable assembly (15) from bracket (3).
3. Remove cotter pin (9) and pin (12) from eye (11) and rod assembly (7). Discard cotter pin (9).
4. Remove two screws (5), lockwashers (6), and bracket (8) from cab frame (4). Discard lockwashers (6).
5. Loosen two nuts (13) and remove cable (15) from bracket (8).
6. Loosen two nuts (10) and remove two eyes (11) and (18) from cable (15).

**b. Inspection**

Inspect bracket (8) for cracks and bends. Replace bracket (8) if cracked or bent.

**c. Installation**

1. Install two eyes (11) and (18) on cable assembly (15) and tighten two nuts (10).

**NOTE**

Access to bracket is through door in cab floor in front of driver's seat.

2. Install bracket (8) on frame (4) with two screws (5) and new lockwashers (6).
3. Install cable (15) on fuel pump lever (2) with pin (17) and new cotter pin (16).
4. Install cable (15) on rod assembly (7) with pin (12) and new cotter pin (9).

**NOTE**

Loosen nuts to adjust cable so fuel pump lever is in curb idle position.

5. Install cable (15) on two brackets (3) and (8) and tighten two nuts (14) and (13).

**12-54. SPEED CONTROL CABLE MAINTENANCE (Contd)**

**d. Adjustment**

1. Start engine and engage PTO (TM 9-2320-361-10). Monitor rpm with STE/ICE.
2. Adjust screw (1) and wire (19) to obtain fuel pump lever (2) position for rpms specified for each vehicle (table 12-1).

*Table 12-1. Speed Control Adjustment.*

MODEL	ENGINE RPM	TRANSMISSION GEAR	PTO RPM
M49A2C	1150	2ND	413
M50A2 & A3	1100	4TH	1100

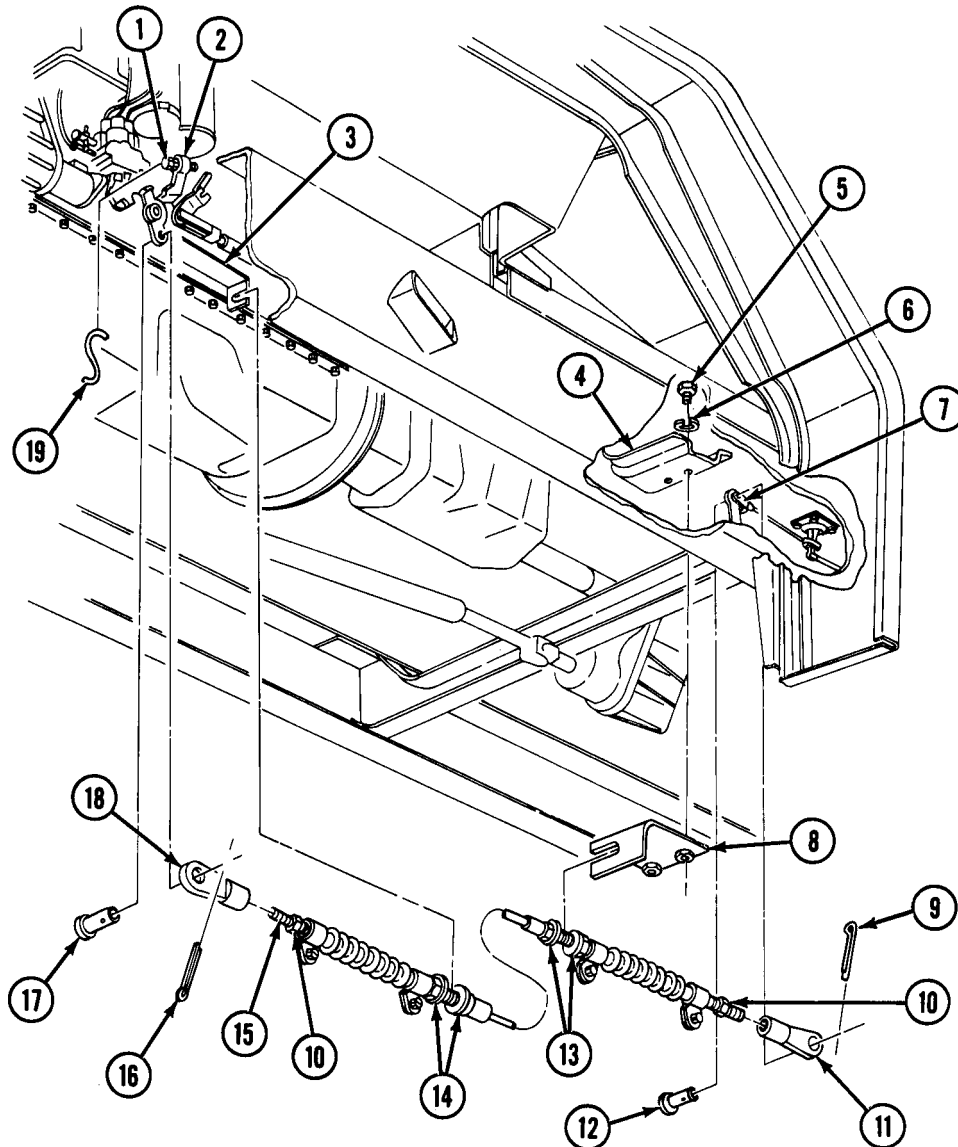



**12-55. TANK BODIES FRONT SPLASH GUARD REPLACEMENT**

This task covers:

**a. Removal**

**b. Installation**

INITIAL SETUP:

APPLICABLE MODELS

M49A2C, M50A2, M50A3

MATERIALS/PARTS

Nine locknuts (M49A2C, M50A3)  
Seven locknuts (M50A2)

REFERENCES (TM)

TM 9-2320-361-10  
TM 9-2320-361-20P

EQUIPMENT CONDITION

Parking brake set (TM 9-2320-361-10).

GENERAL SAFETY INSTRUCTIONS

Keep fire extinguisher nearby when working on fuel tank trucks.

**WARNING**

Do not perform this procedure while smoking or within 50 feet of sparks or open flame. Fuel is flammable and can explode easily, causing injury or death to personnel and damage to equipment.

**NOTE**

Left and right front splash guards are replaced the same way, except for two additional screws on the left side pioneer tool bracket of the M49A2C and M50A3 vehicles.

**a. Removal**

1. Remove two locknuts (8) and screws (9) from braces (7) and splash guard (10). Discard locknuts (8).
2. Remove two locknuts (6), screws (5), and two braces (7) from frame (4). Discard locknuts (6).

**NOTE**

Perform step 3 on left side of M49A2C and M50A3 vehicles.

3. Remove two locknuts (13) and screws (1) from pioneer tool bracket (12) and splash guard (10). Discard locknuts (13).
4. Remove three locknuts (11), screws (3), and splash guard (10) from frame (2). Discard locknuts (11).

**b. Installation**

1. Install splash guard (10) on frame (2) with three screws (3) and new locknuts (11).

**NOTE**

Perform step 2 on left side of M49A2C and M50A3 vehicles.

2. Install pioneer tool bracket (12) on splash guard (10) with two screws (1) and new locknuts (13).
3. Install two braces (7) on frame (4) with two screws (5) and new locknuts (6).
4. Install two braces (7) on splash guard (10) with two screws (9) and new locknuts (8).

12-55. TANK BODIES FRONT SPLASH GUARD REPLACEMENT (Contd)

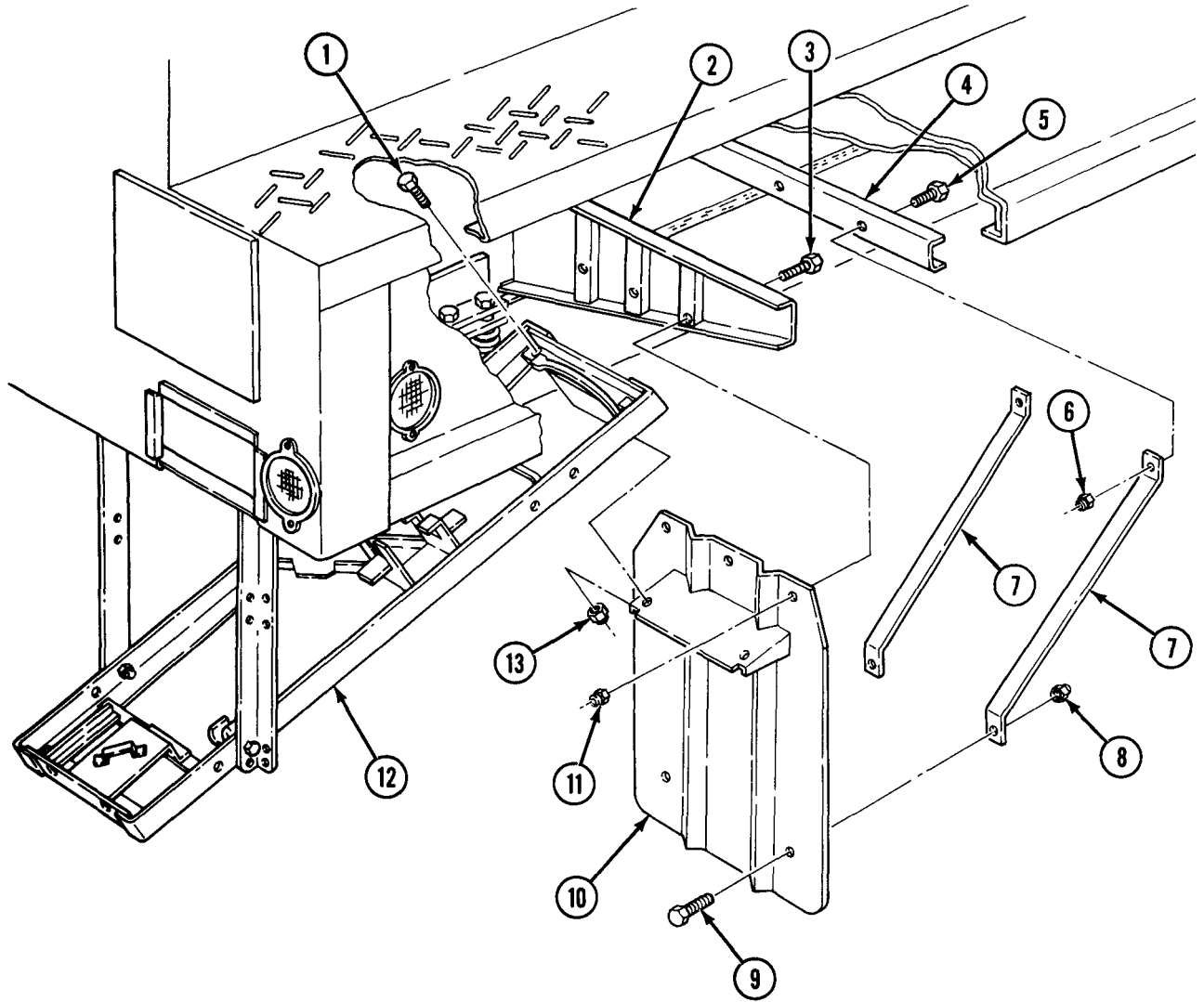

**12-56. TANK BODIES UPPER AND LOWER REAR SPLASH GUARD REPLACEMENT**

This task covers:

- a. Lower Splash Guard Removal
- b. Upper Splash Guard Removal

- c. Upper Splash Guard Installation
- d. Lower Splash Guard Installation

**INITIAL SETUP:**

APPLICABLE MODELS

M49A2C, M50A2, M50A3

MATERIALS/PARTS

Ten locknuts

REFERENCES (TM)

TM 9-2320-361-10

TM 9-2320-361-20P

EQUIPMENT CONDITION

Parking brake set (TM 9-2320-361-10).

GENERAL SAFETY INSTRUCTIONS

Keep fire extinguisher nearby when working on fuel tank trucks.

**WARNING**

Do not perform this procedure while smoking or within 50 feet of sparks or open flame. Fuel is flammable and can explode easily, causing injury or death to personnel and damage to equipment.

**a. Lower Splash Guard Removal**

Remove three locknuts (6), screws (8), retainer strip (9), and lower splash guard (10) from upper splash guard (4). Discard locknuts (6).

**b. Upper Splash Guard Removal**

1. Remove two locknuts (7) and screws (12) from braces (11) and upper splash guard (4). Discard locknuts (7).
2. Remove two locknuts (13), screws (2), and braces (11) from crossmember (1). Discard locknuts (13).
3. Remove three locknuts (5), screws (3), and upper splash guard (4) from crossmember (14). Discard locknuts (5).

**c. Upper Splash Guard Installation**

1. Install upper splash guard (4) on crossmember (14) with three screws (3) and new locknuts (5).
2. Install two braces (11) on crossmember (1) with two screws (2) and new locknuts (13).
3. Install two braces (11) on upper splash guard (4) with two screws (12) and new locknuts (7).

**12-56. TANK BODIES UPPER AND LOWER REAR SPLASH GUARD REPLACEMENT (Contd)****d. Lower Splash Guard Installation**

Install retainer strip (9) and lower splash guard (10) on upper splash guard (4) with three screws (8) and new locknuts (6).

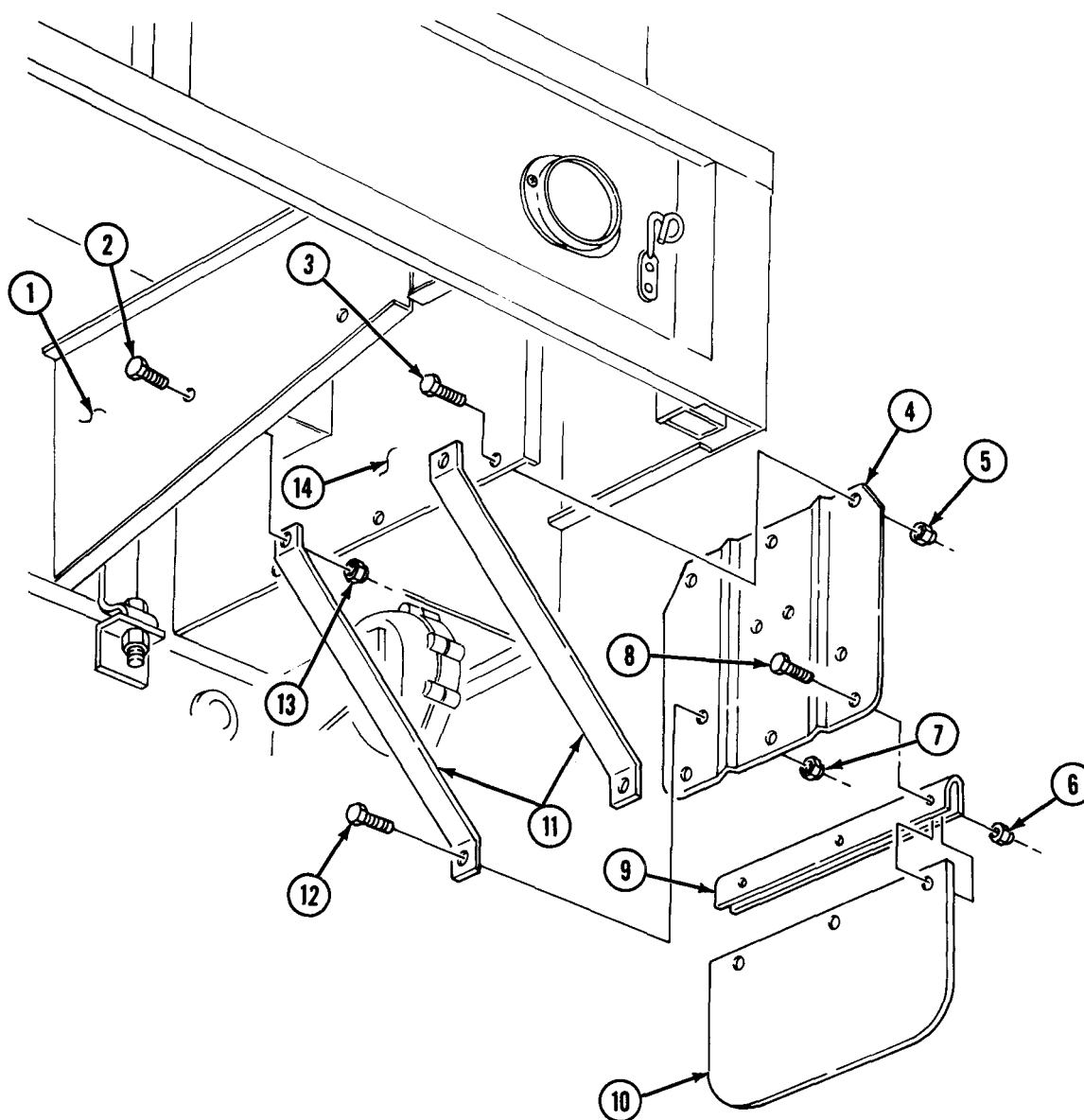

Section IV. VAN BODY MAINTENANCE

**12-57. VAN BODY MAINTENANCE INDEX**

PARA. NO.	TITLE	PAGE NO.
12-58.	Rear Splash Guard Replacement	12-94
12-59.	Safety Switch Fuse Replacement	12-96
12-60.	Exhaust Blower Motor and Bracket Replacement	12-97
12-61.	Dome Lamp and Housing Replacement	12-98
12-62.	Van Door Replacement	12-100
12-63.	Van Door Seals Replacement	12-101
12-64.	Van Door Repair	12-102
12-65.	24V Circuit Breaker Replacement	12-105
12-66.	Vehicle Boarding Ladder Replacement	12-106
12-67.	Converter Selector Switch Replacement	12-108
12-68.	Exhaust Blower Switch Replacement	12-110
12-69.	Converter Replacement	12-112
12-70.	Van Bodies Front Splash Guard Replacement	12-113
12-71.	Van Body Tool Replacement	12-114
12-72.	Converter Receptacle Replacement	12-118
12-73.	Floodlight Bracket Replacement	12-120
12-74.	Access Door Moulding and Access Plate Replacement	12-121
12-75.	Power Switch Maintenance	12-122
12-76.	Door Holder Assembly and Bracket Replacement	12-124
12-77.	Door Check Replacement	12-125
12-78.	Exhaust Blower Duct Assembly Replacement	12-126
12-79.	Blower Motor Receptacle Replacement	12-127
12-80.	Blackout Switch Replacement	12-128
12-81.	Fuel Line Adapter Replacement	12-130
12-82.	Side Rail Maintenance	12-131

**12-58. REAR SPLASH GUARD REPLACEMENT**

This task covers:

- a. Lower Splash Guard Removal
- b. Upper Splash Guard Removal

- c. Upper Splash Guard Installation
- d. Lower Splash Guard Installation

**INITIAL SETUP:**

APPLICABLE MODELS  
M185A3, M109A3

MATERIALS/PARTS  
Ten locknuts

REFERENCES (TM)  
TM 9-2320-361-10  
TM 9-2320-361-20P

EQUIPMENT CONDITION  
Parking brake set (TM 9-2320-361-10).

## 12-58. REAR SPLASH GUARD REPLACEMENT (Contd)

### a. Lower Splash Guard Removal

Remove four locknuts (9), screws (5), retainer strip (8), and lower splash guard (7) from upper splash guard (10). Discard locknuts (9).

### b. Upper Splash Guard Removal

1. Remove two locknuts (11) and screws (6) from two splash guard braces (12). Discard locknuts (11).
2. Remove two locknuts (1), screws (4), and splash guard braces (12) from frame (2). Discard locknuts (1).
3. Remove two locknuts (13), screws (3), and upper splash guard (10) from frame (2). Discard locknuts (13).

### c. Upper Splash Guard Installation

1. Install upper splash guard (10) on frame (2) with two screws (3) and new locknuts (13).
2. Install two splash guard braces (12) on frame (2) with two screws (4) and new locknuts (1).
3. Install splash guard braces (12) on upper splash guard (10) with two screws (6) and new locknuts (11).

### d. Lower Splash Guard Installation

1. Aline holes in lower splash guard (7) to holes in retainer strip (8).
2. Install retainer strip (8) and lower splash guard (7) on upper splash guard (10) with four screws (5) and new locknuts (9).

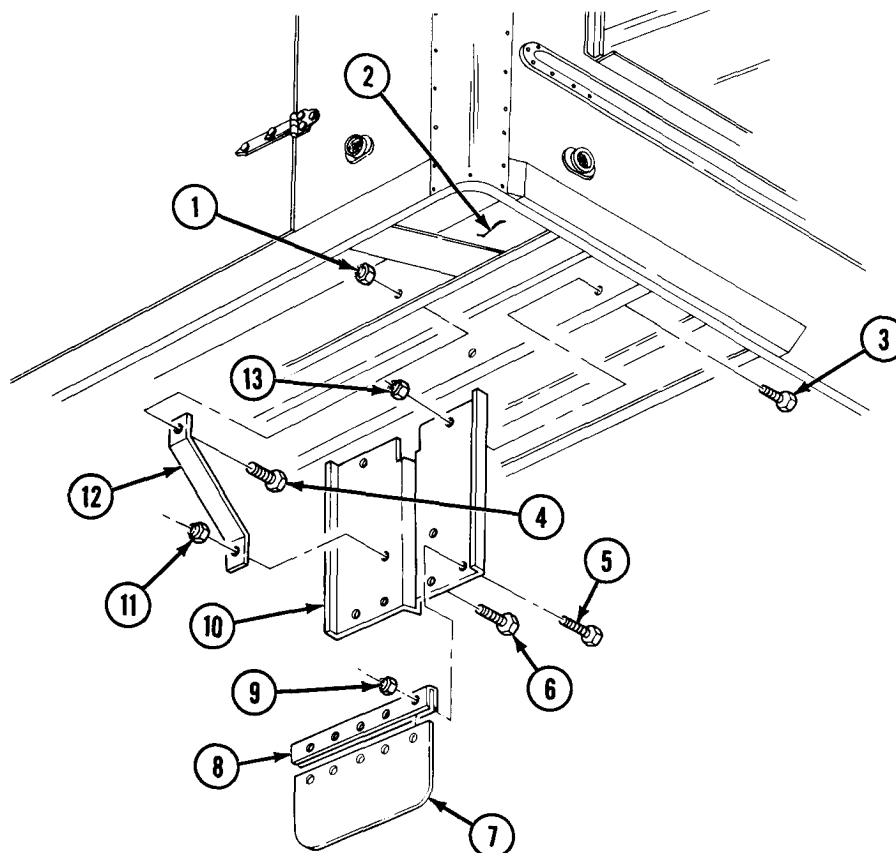

## 12-59. SAFETY SWITCH FUSE REPLACEMENT

This task covers:

### a. Removal

### b. Installation

INITIAL SETUP:

#### APPLICABLE MODELS

M185A3, M109A3

#### MATERIALS/PARTS

Two 250V fuses

#### REFERENCES (TM)

TM 9-2320-361-10

TM 9-2320-361-20P

#### EQUIPMENT CONDITION

1 Parking brake set (TM 9-2320-361-10).

1 Battery ground cable disconnected (para. 4-48).

### a. Removal

1. Pull safety switch box handle (2) down to OFF position and open cover (4).
2. Remove two 250V fuses (3) from safety switch box (1). Discard fuses (3).

### b. Installation

1. Install two new 250V fuses (3) in safety switch box (1).
2. Close cover (4) and push safety switch box handle (2) up to ON position.

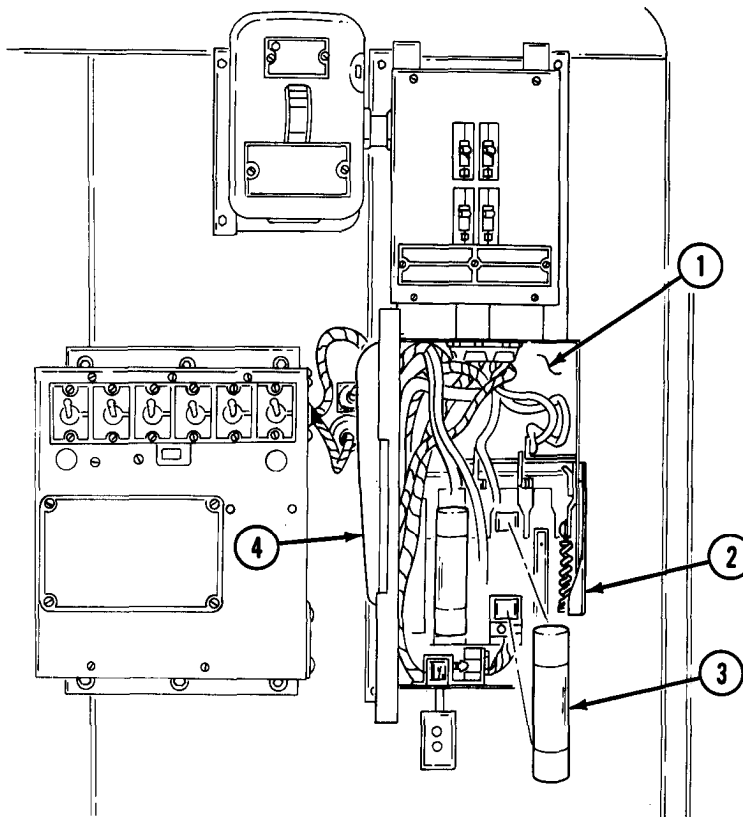

FOLLOW-ON TASK: Connect battery ground cable (para. 4-48).

## 12-60. EXHAUST BLOWER MOTOR AND BRACKET REPLACEMENT

This task covers:

### a. Removal

### b. Installation

#### INITIAL SETUP:

##### APPLICABLE MODELS

M185A3, M109A3

##### MATERIALS/PARTS

Eight screw-assembled lockwashers

##### REFERENCES (TM)

TM 9-2320-361-10

TM 9-2320-361-20P

##### EQUIPMENT CONDITION

- Parking brake set (TM 9-2320-361-10).
- Ž Battery ground cable disconnected (para. 4-48).

### a. Removal

1. Remove blower motor cable (4) from receptacle (9).
2. Remove two screw-assembled lockwashers (2) from bracket (3) and ceiling (1). Discard screw-assembled lockwashers (2).
3. Remove six screw-assembled lockwashers (6) and blower motor assembly (5) from adapter (8). Discard screw-assembled lockwashers (6).
4. Remove two nuts (7) and bracket (3) from blower motor (5).

### b. Installation

1. Install bracket (3) on blower motor (5) with two nuts (7).
2. Install blower motor assembly (5) on adapter (8) with six new screw-assembled lockwashers (6).
3. Install bracket (3) on ceiling (1) with two new screw-assembled lockwashers (2).
4. Insert blower motor cable (4) into receptacle (9).

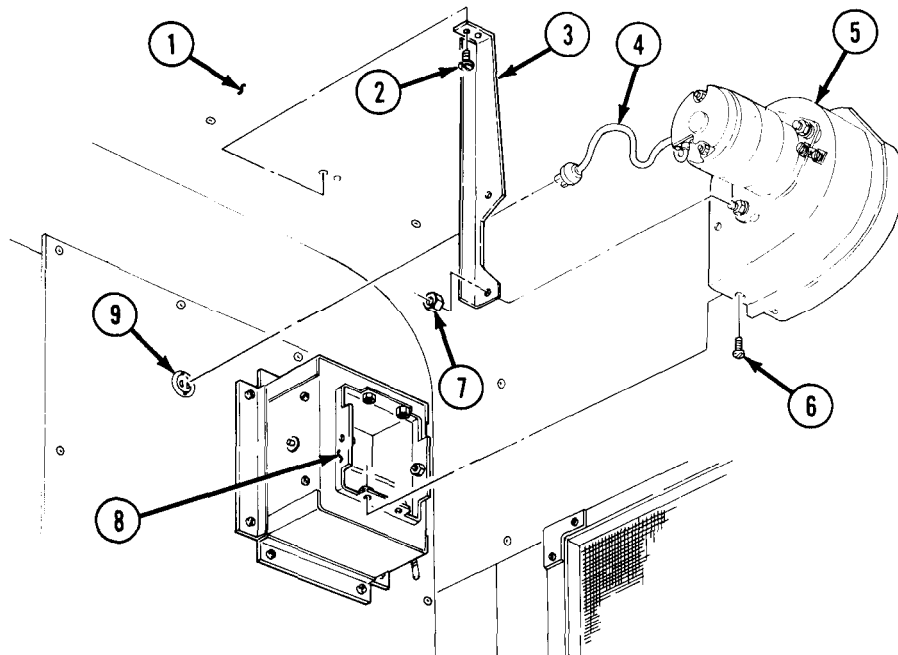

FOLLOW-ON TASK: Connect battery ground cable (para. 4-48).



## 12-61. DOME LAMP AND HOUSING REPLACEMENT

This task covers:

a. Removal

b. Installation

### INITIAL SETUP:

#### APPLICABLE MODELS

M185A3, M109A3

#### MATERIALS/PARTS

Gasket

Adhesive (Appendix C, Item 3)

#### REFERENCES (TM)

TM 9-2320-361-10

TM 9-2320-361-20P

#### EQUIPMENT CONDITION

- Parking brake set (TM 9-2320-361-10).
- Battery ground cable disconnected (para. 4-48).

### a. Removal

1. Loosen screw (5) from dome light housing (12) and open dome light door (4).

#### NOTE

For 24V lamp replacement, push in lamp to unscrew.

2. Remove lamp (10) from dome light housing (12).
3. Remove screw (5), clip (6), washer (7), and lens (8) from dome light door (4).
4. Remove gasket (9) from dome light housing (12). Discard gasket (9).

#### NOTE

- Hold dome light assembly up to keep weight off wires.
- Tag wires for installation.

5. Remove four screws (11) and dome light housing (12) from ceiling (1).
6. Remove two screws (3) and wires (2) from dome light housing (12).

### b. Installation

1. Install lens (8) on dome light door (4) with clip (6), washer (7), and screw (5).
2. Apply adhesive to new gasket (9) and install on dome light housing (12).
3. Install lamp (10) on dome light housing (12).
4. Install two wires (2) on dome light housing (12) with two screws (3).
5. Install dome light housing (12) on ceiling (1) with four screws (11).
6. Close dome light door (4) and tighten screw (5).

**12-61. DOME LAMP AND HOUSING REPLACEMENT (Contd)**

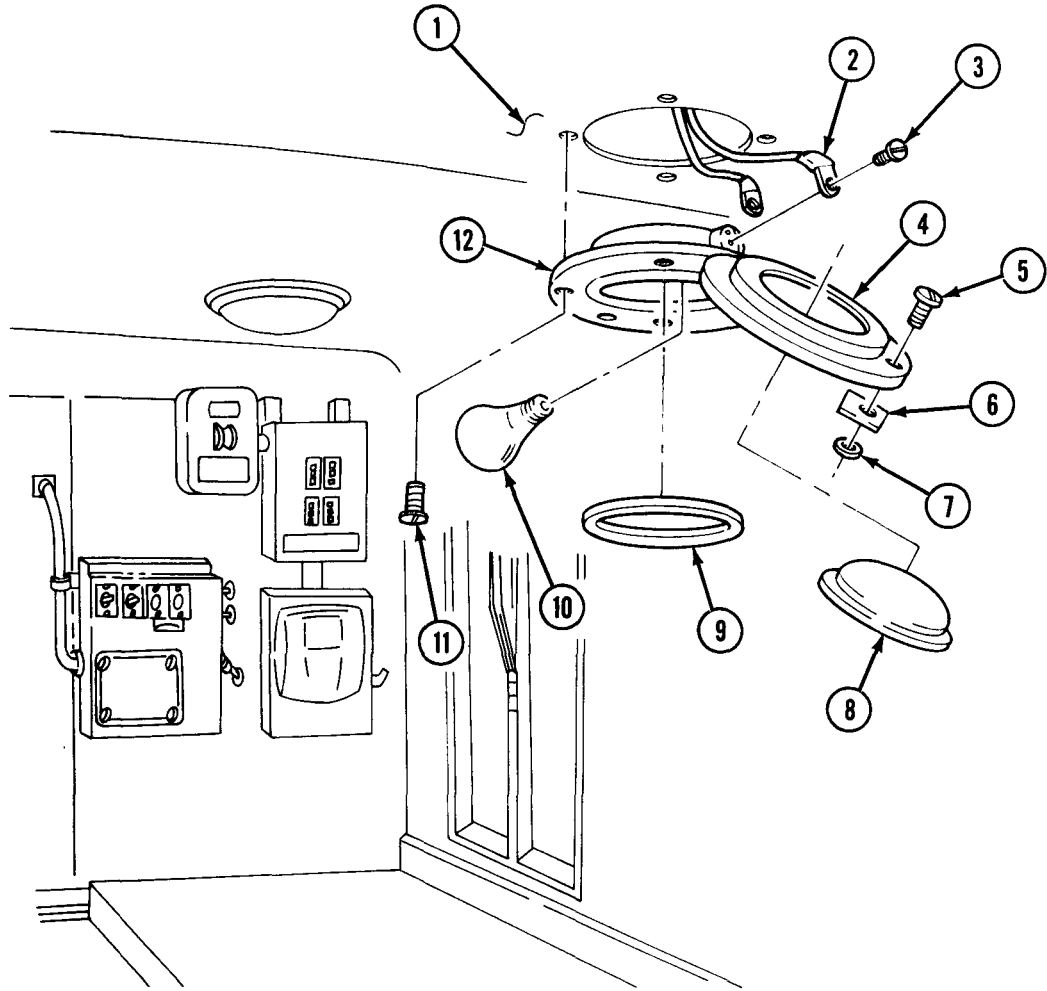

FOLLOW-ON TASK Connect battery ground cable (para. 4-48).

## 12-62. VAN DOOR REPLACEMENT

This task covers

### a. Removal

### b. Installation

INITIAL SETUP:

APPLICABLE MODELS

M109A3, M185A3

MATERIALS/PARTS

Six lockwashers  
Three locknuts

PERSONNEL REQUIRED

Two

REFERENCES (TM)

TM 9-2320-361-10

TM 9-2320-361-20P

EQUIPMENT CONDITION

- Parking brake set (TM 9-2320-361-10).
- Ladder removed (para. 12-66).
- Door handle and lock assembly removed (para. 12-64).

### a. Removal

1. Remove two screws (2) and pull door check (1) away from van door (8).
2. Remove six screws (6) and lockwashers (5) from three hinges (3) and van door (8). Discard lockwashers (5).

NOTE

Assistant will help with step 3.

3. Remove three locknuts (7), screws (4), and van door (8) from three hinges (3). Discard locknuts (7).

NOTE

Assistant will help with step 1.

1. Install van door (8) on three hinges (3) with three screws (4) and new locknuts (7).
2. Install six screws (6) and new lockwashers (5) on three hinges (3) and van door (8).
3. Install door check (1) to van door (8) with two screws (2).

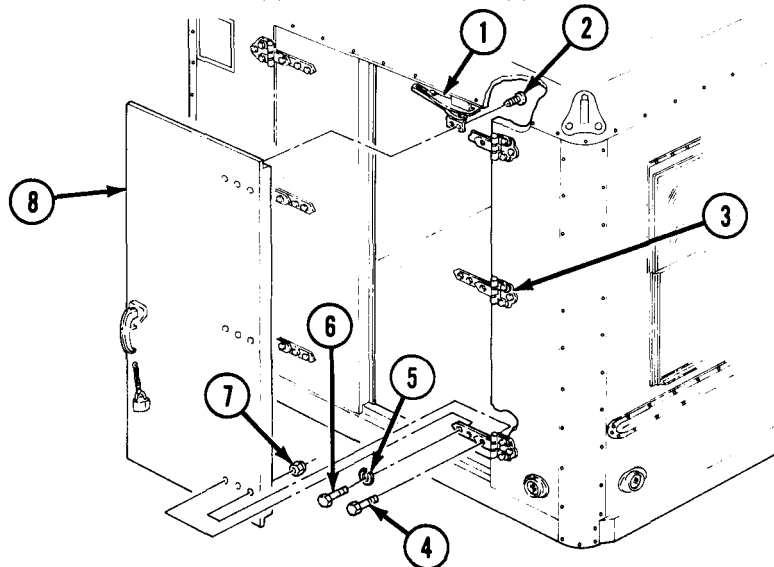

- FOLLOW-ON TASKS:
- Install door handle and lock assembly (para. 12-64).
  - Install ladder (para. 12-66).

## 12-63. VAN DOOR SEALS REPLACEMENT

This task covers:

- a. Removal
- b. Cleaning

c. Installation

### INITIAL SETUP:

#### APPLICABLE MODELS

M185A3, M109A3

#### MATERIALS/PARTS

Five seals

Adhesive (Appendix C, Item 2)

Drycleaning solvent (Appendix C, Item 26)

#### REFERENCES (TM)

TM 9-2320-361-10

TM 9-2320-361-20P

#### EQUIPMENT CONDITION

- Parking brake set (TM 9-2320-361-10).
- Van doors open (TM 9-2320-361-10).
- Ladder removed (para. 12-66).

#### GENERAL SAFETY INSTRUCTIONS

Keep fire extinguisher nearby when using dry-cleaning solvent.

### **NOTE**

Secure van doors in open position.

#### **a. Removal**

1. Remove four seals (2) from bottom, top, and side channels (3). Discard seals (2).
2. Remove seal (5) from channel (4) on left van door (1). Discard seals (5).

#### **b. Cleaning**

### **WARNING**

Drycleaning solvent is flammable and will not be used near open flame. Use only in well-ventilated places. Failure to do so may result in injury to personnel.

Clean adhesive remains from all four sides of channel (3) and channel (4) on left van door.

#### **c. Installation**

1. Apply adhesive to top, bottom, and side channels (3) and channel (4) on left van door (1).
2. Install four new seals (2) on top, bottom, and side channels (3).
3. Install new seal (5) on channel (4) on left van door (1).

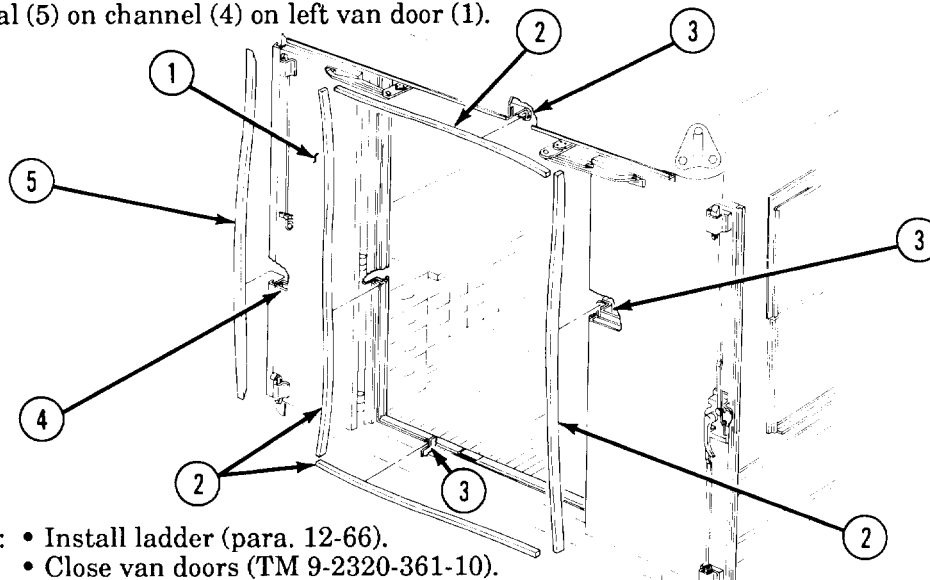

- FOLLOW-ON TASKS:**
- Install ladder (para. 12-66).
  - Close van doors (TM 9-2320-361-10).

## 12-64. VAN DOOR REPAIR

This task covers:

- |   |   |
|---|---|
| <ul style="list-style-type: none"> <li>a. Left Van Door Disassembly</li> <li>b. Right Van Door Disassembly</li> <li>c. Cleaning and Inspection</li> </ul> | <ul style="list-style-type: none"> <li>d. Right Van Door Assembly</li> <li>e. Left Van Door Assembly</li> </ul> |
|---|---|

### INITIAL SETUP:

#### APPLICABLE MODELS

M185A3, M109A3

#### MATERIALS/PARTS

Seventeen lockwashers  
 Three cotter pins  
 Two screw-assembled lockwashers  
 Drycleaning solvent (Appendix C, Item 26)

#### REFERENCES (TM)

TM 9-2320-361-10  
 TM 9-2320-361-20P

#### EQUIPMENT CONDITION

- Parking brake set (TM 9-2320-361-10).
- Van door(s) removed (para. 12-62).

#### GENERAL SAFETY INSTRUCTIONS

Keep fire extinguisher nearby when using drycleaning solvent.

### **a. Left Van Door Disassembly**

1. Remove four screws (11), lockwashers (12), and latch (13) from van door (4). Discard lockwashers (12).
2. Remove two screws (8), lockwashers (9), and plate (10) from van door (4). Discard lockwashers (9).
3. Remove two screw-assembled lockwashers (6) and guide (7) from rod (5) and van door (4). Discard screw-assembled lockwashers (6).
4. Remove four screws (1), lockwashers (2), lock (3), and rod (5) from van door (4). Discard lockwashers (2).
5. Remove two screws (14) and holder (15) from van door (4).

### **b. Right Van Door Disassembly**

1. Remove eight screws (24), four spacers (18), and two guides (16) from van door (17).
2. Remove four screws (23), lockwashers (22), and lock (21) from van door (17). Discard lockwashers (22).
3. Remove two screws (25), upper rod (19), and lower rod (26) from two guides (16).
4. Remove two cotter pins (20) and (27), upper rod (19), and lower rod (26) from lock (21). Discard cotter pins (20) and (27).
5. Remove cotter pin (29) and inside door handle (28) from van door (17). Discard cotter pin (29).
6. Remove two screws (30) and holder (31) from van door (17).
7. Remove three screws (32), lockwashers (33), spacer (35), and outside handle (34) from van door (17). Discard lockwashers (33).
8. Remove screw (36) and padlock (37) from van door (17).

### **c. Cleaning and Inspection**

1. Inspect latch (13), plates (10), guides (7) and (16), lock (21), rods (26), (5), and (19), handles (28) and (34), and doors (4) and (17) for cracks, bends, and excessive wear. Replace components which are cracked, bent, or excessively worn.

**12-64. VAN DOOR REPAIR (Contd)**

**WARNING**

Drycleaning solvent is flammable and will not be used near an open flame. Use only in well-ventilated places. Failure to do so may result in injury to personnel.

2. Clean latch (13), plates (10), guides (7) and (16), lock (21), rods (19), (5), and (26), and handles (28) and (34) with drycleaning solution. Air dry all parts.

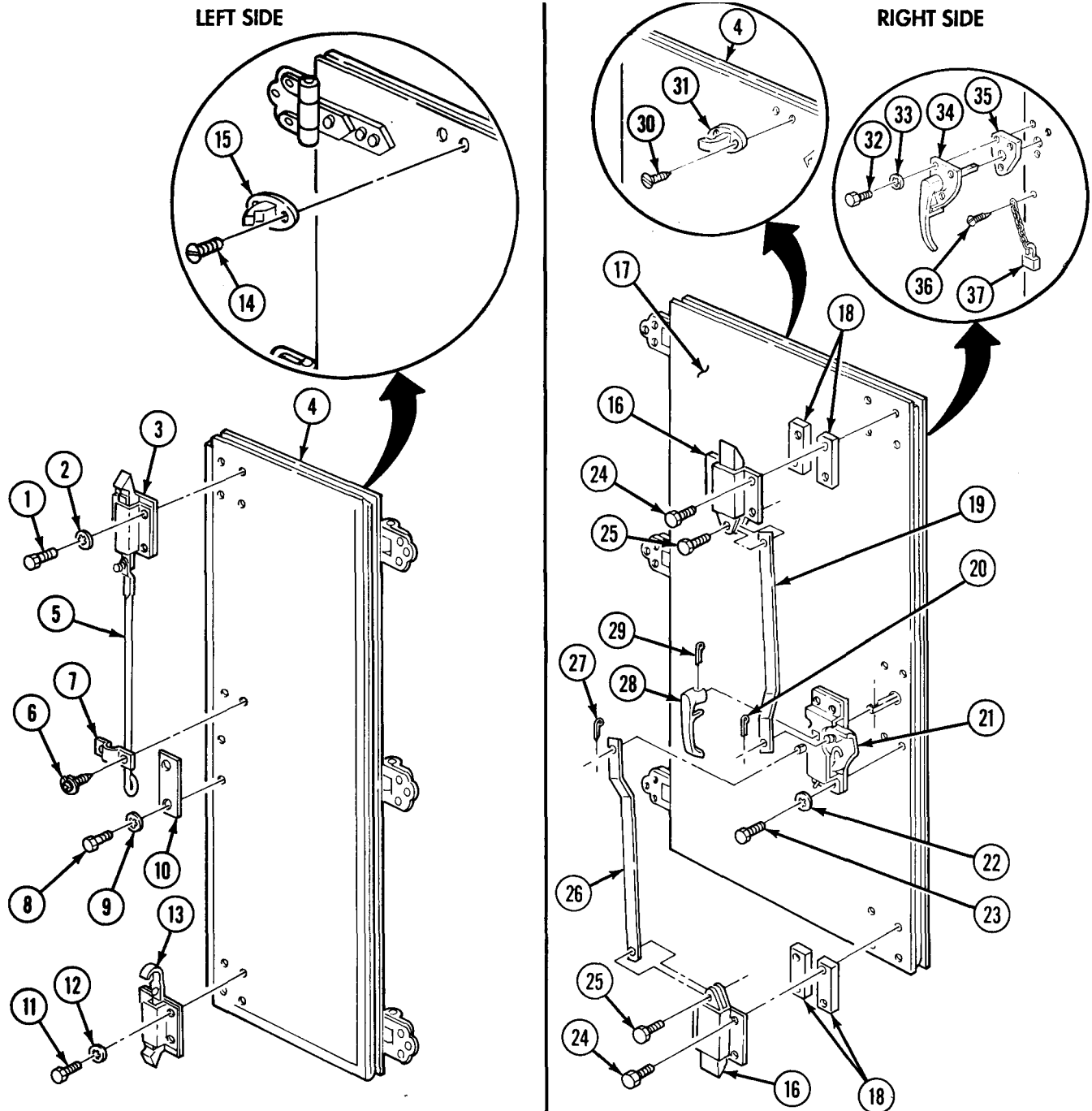

## 12-64. VAN DOOR REPAIR (Contd)

### d. Right Van Door Assembly

1. Install padlock (21) on van door (1) with screw (22).
2. Install spacer (20) and outside door handle (19) on van door (1) with three screws (17) and new lockwashers (18).
3. Install holder (16) on van door (1) with two screws (15).
4. Install inside door handle (13) on van door (1) with new cotter pin (14).
5. Install upper and lower rods (11) and (3) on lock (5) with two new cotter pins (4) and (12).
6. Install rods (3) and (11) on two guides (8) with two screws (10).
7. Install lock (5) on van door (1) with four screws (7) and new lockwashers (6).
8. Install four spacers (2) and two guides (8) on van door (1) with eight screws (9).

### e. Left Van Door Assembly

1. Install holder (37) on van door (26) with two screws (36).
2. Install lock (25) and rod (27) on van door (26) with four screws (23) and new lockwashers (24).
3. Install guide (28) on van door (26) with two new screw-assembled lockwashers (29).
4. Install plate (32) on van door (26) with two screws (30) and new lockwashers (31).
5. Install latch (35) on van door (26) with four screws (33) and new lockwashers (34).

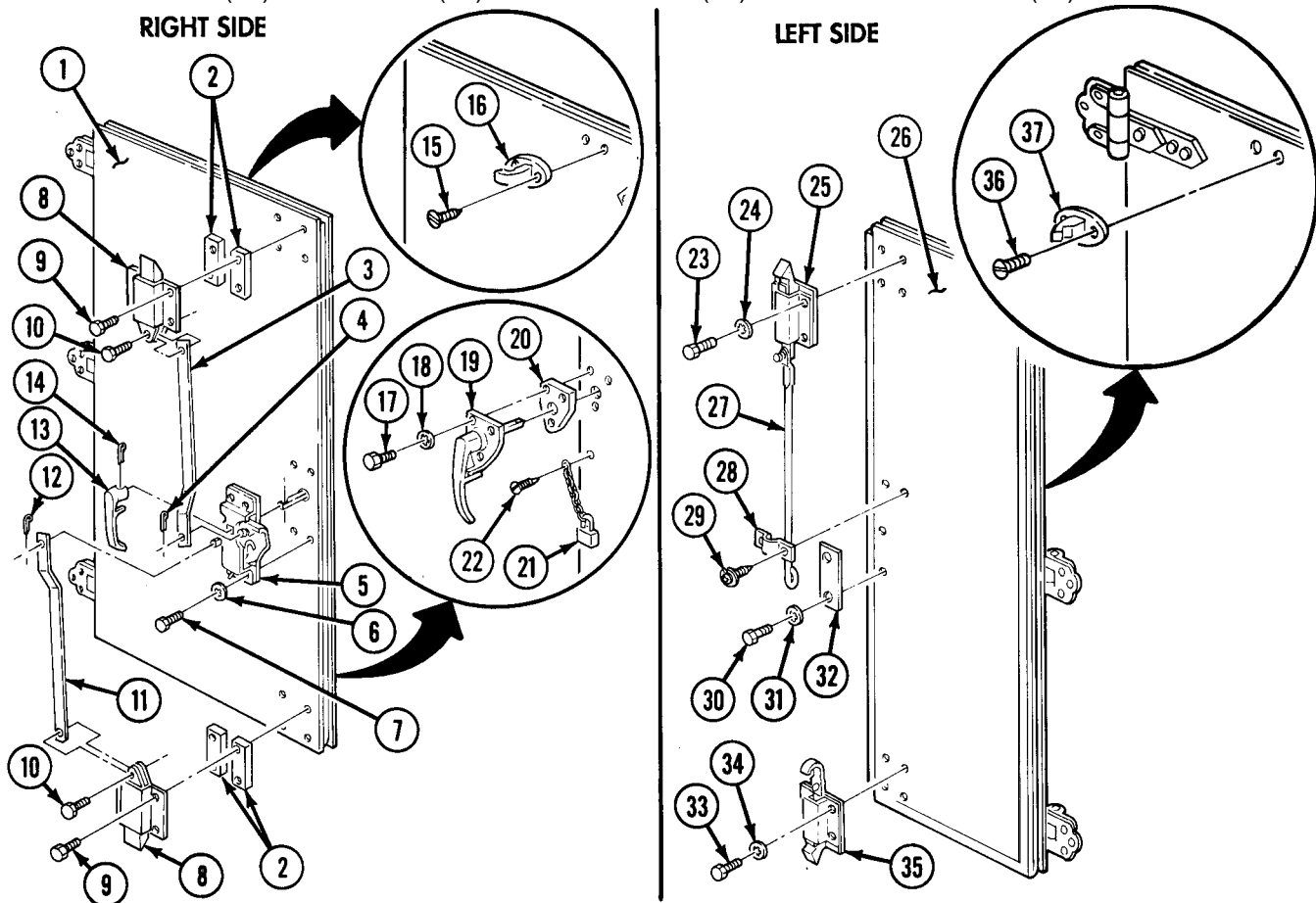

FOLLOW-ON TASK Install van door(s) (para. 12-62).

## 12-65. 24V CIRCUIT BREAKER REPLACEMENT

This task covers:

### a. Removal

### b. Installation

INITIAL SETUP:

#### APPLICABLE MODELS

M185A3, M109A3

#### MATERIALS/PARTS

Two lockwashers

#### REFERENCES (TM)

TM 9-2320-361-10

TM 9-2320-361-20P

#### EQUIPMENT CONDITION

- Parking brake set (TM 9-2320-361-10).
- Battery ground cable disconnected (para. 4-48).

### a. Removal

1. Disconnect two wires (4) from circuit breaker (3).
2. Remove two nuts (1), lockwashers (2), screws (5), and circuit breaker (3) from van body (6). Discard lockwashers (2).

### b. Installation

1. Install circuit breaker (3) on van body (6) with two screws (5), new lockwashers (2), and nuts (1).
2. Connect two wires (4) to circuit breaker (3).

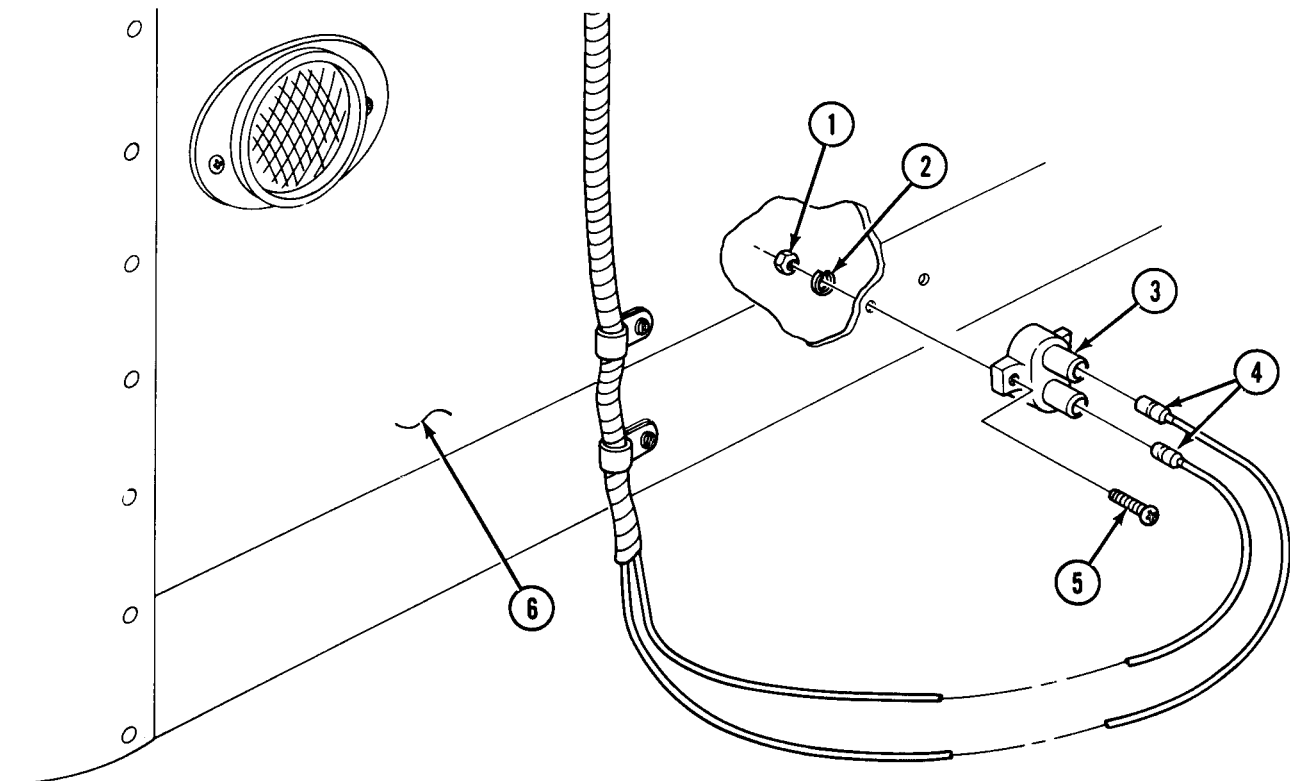

FOLLOW-ON TASK: Connect battery ground cable (para. 4-48).



## 12-66. VEHICLE BOARDING LADDER REPLACEMENT

This task covers:

### a. Removal

### b. Installation

#### INITIAL SETUP:

##### APPLICABLE MODELS

M185A3, M109A3

##### MATERIALS/PARTS

Ten locknuts

##### REFERENCES (TM)

TM 9-2320-361-10

TM 9-2320-361-20P

##### EQUIPMENT CONDITION

Parking brake set (TM 9-2320-361-10).

### a. Removal

1. Remove fastener (9) from catch (5) and ladder (3).
2. Remove ladder (3) from brackets (4) and retainer (12).
3. Remove four locknuts (11), screws (7), two spacers (10), and brackets (4) from van body (1). Discard locknuts (11).
4. Remove three locknuts (8) and fastener (9) from bracket (4). Discard locknuts (8).
5. Remove two screws (2) and retainer (12) from van body (1).
6. Remove three locknuts (6) and catch (5) from ladder (3). Discard locknuts (6).

### b. Installation

1. Install catch (5) on ladder (3) with three new locknuts (6).
2. Install retainer (12) on van body (1) with two screws (2).
3. Install fastener (9) on bracket (4) with three new locknuts (8).
4. Install two spacers (10) and brackets (4) on van body (1) with four screws (7) and new locknuts (11).
5. Install ladder (3) on brackets (4) and attach fastener (9) on catch (5).

**12-66. VEHICLE BOARDING LADDER REPLACEMENT (Contd)**

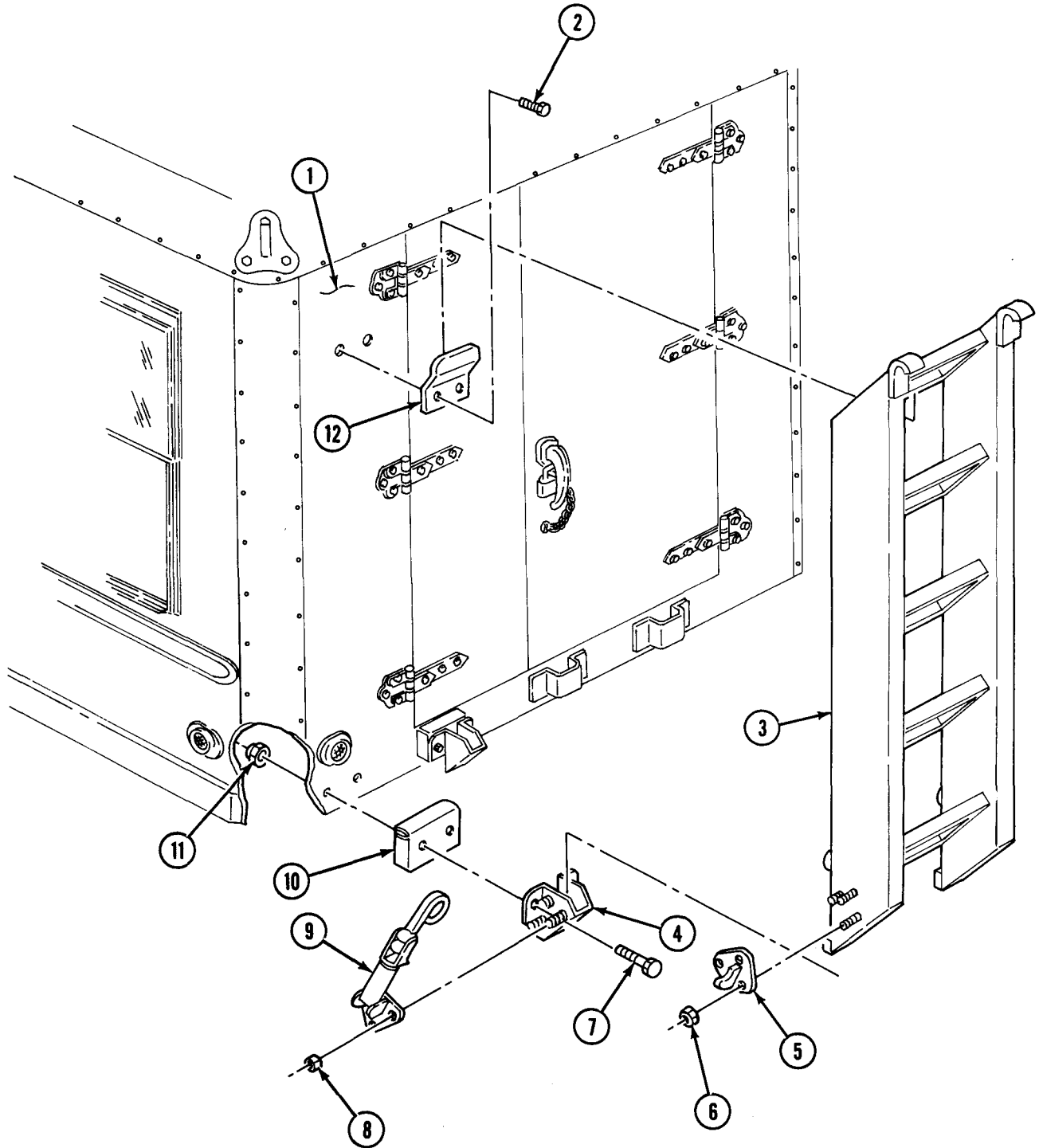

## 12-67. CONVERTER SELECTOR SWITCH REPLACEMENT

This task covers:

**a. Removal**

**b. Installation**

**INITIAL SETUP:**

APPLICABLE MODELS

M109A3, M185A3

MATERIALS/PARTS

Five lockwashers

REFERENCES (TM)

TM 9-2320-361-10

TM 9-2320-361-20P

EQUIPMENT CONDITION

- Parking brake set (TM 9-2320-361-10).
- Converter removed (para. 12-69).

**a. Removal**

1. Remove fourteen screws (11) from converter front panel (3) and converter (6).
2. Turn screw (9) and open door (10). Pull converter front panel (3) away from converter (6).
3. Remove two screws (1), selector switch (4), and identification plate (2) from converter front panel (3).

**NOTE**

Tag wires for installation,

4. Remove five screws (8), lockwashers (5), and six wires (7) from selector switch (4). Discard lockwashers (5).
1. Install six wires (7) on selector switch (4) with five new lockwashers (5) and screws (8).
2. Install identification plate (2) and selector switch (4) on converter front panel (3) with two screws (1).
3. Install converter front panel (3) on converter (6) with fourteen screws (11).
4. Close door (10) and turn screw (9).

**12-67. CONVERTER SELECTOR SWITCH REPLACEMENT (Contd)**

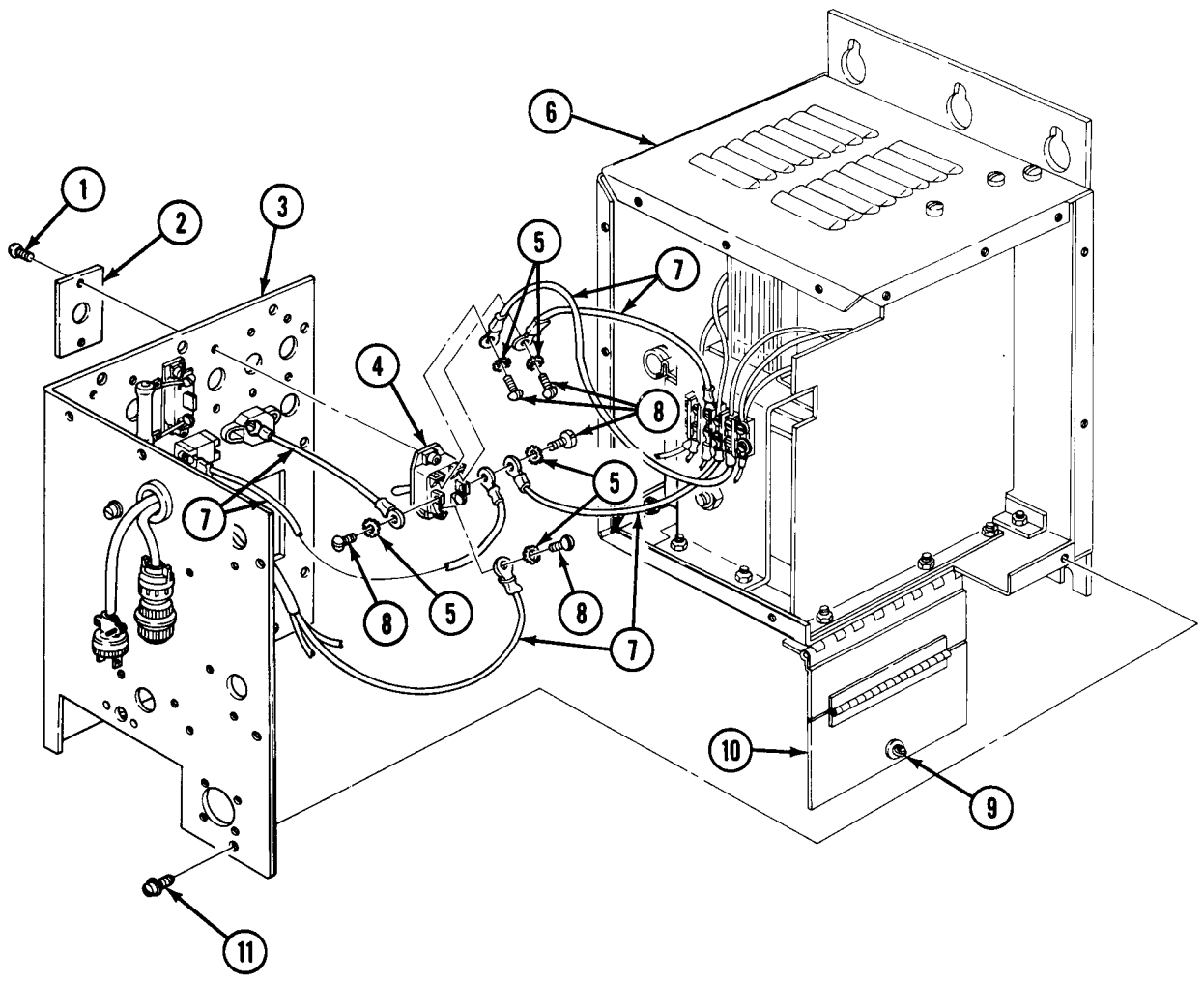

**FOLLOW-ON TASK:** Install converter (para. 12-69).

## 12-68. EXHAUST BLOWER SWITCH REPLACEMENT

This task covers:

a. Removal

b. Installation

### INITIAL SETUP:

**APPLICABLE MODELS**

M185A3, M109A3

**MATERIALS/PARTS**

Three lockwashers

**REFERENCES (TM)**

TM 9-2320-361-10

TM 9-2320-361-20P

**EQUIPMENT CONDITION**

- Parking brake set (TM 9-2320-361-10).
- Converter removed (para. 12-69).

### a. Removal

1. Remove fourteen screws (13) from converter front panel (3) and converter (6).
2. Turn screw (9) and open door (10). Pull converter front panel (3) away from converter (6).
3. Remove two screws (1), exhaust blower switch (4), and identification plate (2) from converter front panel (3).

NOTE

Tag all wires for installation.

4. Remove three screws (8), lockwashers (7), resistor (5), and two wires (11) and (12) from exhaust blower switch (4). Discard lockwashers (7).

### b. Installation

1. Install wire (12) on exhaust blower switch (4) with new lockwasher (7) and screw (8).
2. Install resistor (5) and wire (11) on exhaust blower switch (4) with two new lockwashers (7) and screws (8).
3. Install exhaust blower switch (4) and identification plate (2) on converter front panel (3) with two screws (1).
4. Install converter front panel (3) on converter (6) with fourteen screws (13).
5. Close door (10) and turn screw (9).

**12-68. EXHAUST BLOWER SWITCH REPLACEMENT (Contd)**

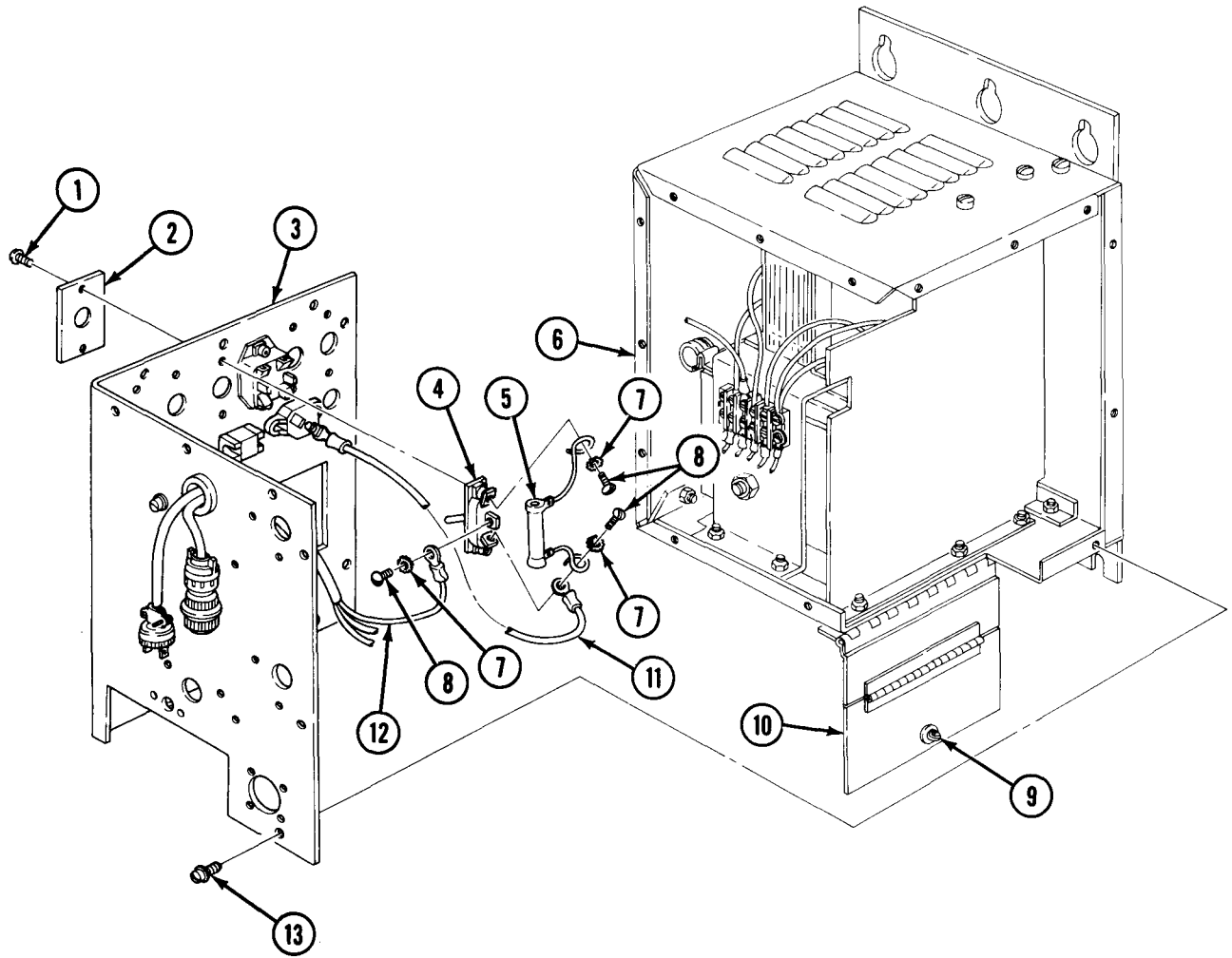

FOLLOW-ON TASK: Install converter (para. 12-69).

## 12-69. CONVERTER REPLACEMENT

This task covers:

**a. Removal**

**b. Installation**

**INITIAL SETUP:**

**APPLICABLE MODELS**

M185A3, M109A3

**MATERIALS/PARTS**

Six lockwashers

**REFERENCES (TM)**

TM 9-2320-361-10

TM 9-2320-361-20P

**EQUIPMENT CONDITION**

Parking brake set (TM 9-2320-361-10).

**a. Removal**

1. Remove plug (5) from receptacle (6).
2. Remove plug (8) from receptacle (7).
3. Loosen six screws (1) and remove converter (9) from van body (4).
4. Remove six screws (1), lockwashers (2), and washers (3), from van body (4). Discard lockwashers (2).

**b. Installation**

1. Install six washers (3), new lockwashers (2), and screws (1) on van body (4). Do not tighten screws (1).
2. Install converter (9) on van body (4) and tighten six screws (1).
3. Install plug (8) on receptacle (7).
4. Screw plug (5) into receptacle (6).

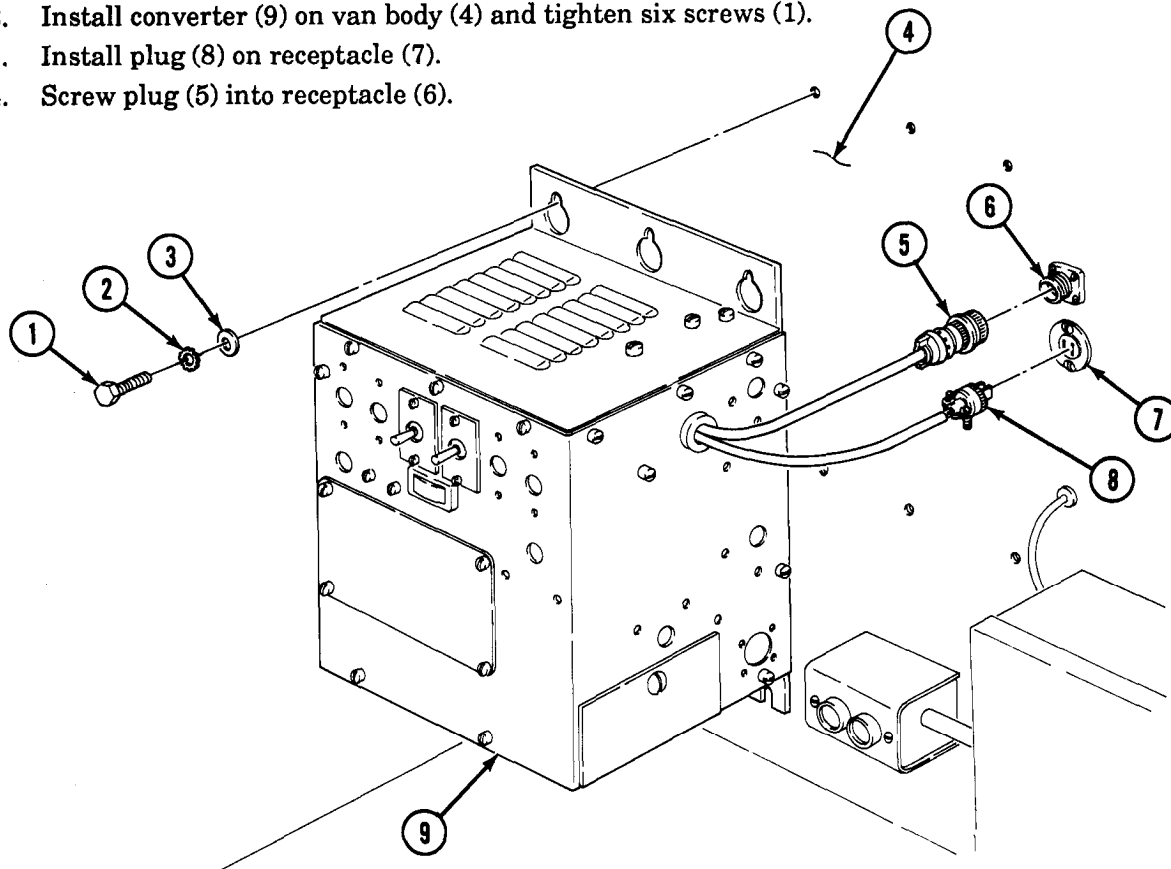

## 12-70. VAN BODIES FRONT SPLASH GUARD REPLACEMENT

This task covers:

### a. Removal

### b. Installation

#### INITIAL SETUP:

##### APPLICABLE MODELS

M109A3, M185A3

##### MATERIALS/PARTS

Eight locknuts

##### REFERENCES (TM)

TM 9-2320-361-10

TM 9-2320-361-20P

##### EQUIPMENT CONDITION

Parking brake set (TM 9-2320-361-10).

#### NOTE

Left and right front splash guards are removed the same, except for two additional screws for the pioneer tool bracket on the left side. This procedure is for the left front splash guard.

### a. Removal

1. Remove two locknuts (6) and screws (3) from two braces (9) and frame (4). Discard locknuts (6).
2. Remove two locknuts (11), screws (8), and two braces (9) from splash guard (10). Discard locknuts (11).
3. Remove two locknuts (12) and screws (7) from pioneer tool bracket (13) and splash guard (10). Discard locknuts (12).
4. Remove two locknuts (1), screws (5), and splash guard (10) from frame (2). Discard locknuts (1).

### b. Installation

1. Install splash guard (10) on frame (2) with two screws (5) and new locknuts (1).
2. Install pioneer tool bracket (13) on splash guard (10) with two screws (7) and new locknuts (12).
3. Install two braces (9) on frame (4) with two screws (3) and new locknuts (6).
4. Install two braces (9) on splash guard (10) with two screws (8) and new locknuts (11).

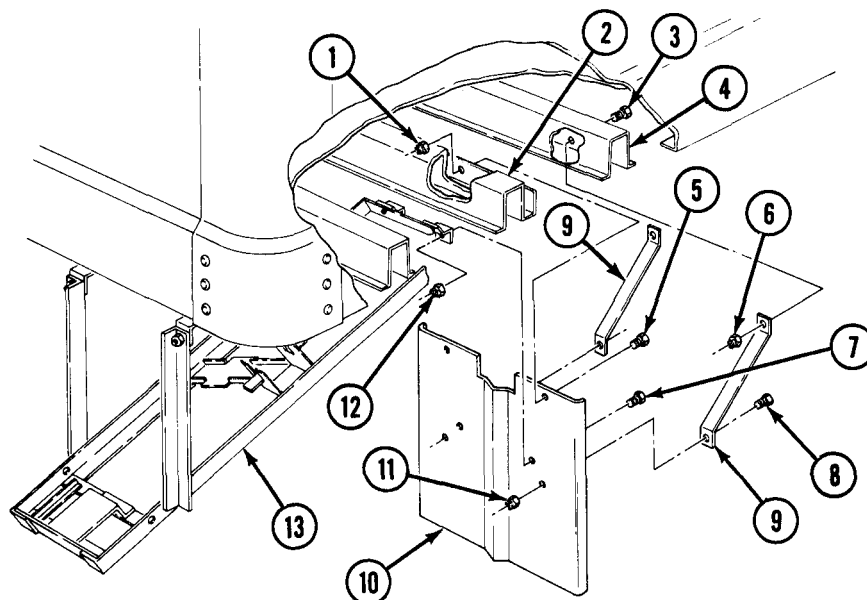



## 12-71. VAN BODY TOOL REPLACEMENT

### This task covers:

- |   |  |
|---|--|
| a. Compressor Removal                   | f. Drill and Stand Installation              |
| b. Vice and Machine Swivel Base Removal | g. Grinding Machine Installation             |
| c. Fire Extinguisher Bracket Removal    | h. Fire Extinguisher Bracket Installation    |
| d. Grinding Machine Removal             | i. Vice and Machine Swivel Base Installation |
| e. Drill and Stand Removal              | j. Compressor Installation                   |

### INITIAL SETUP:

#### APPLICABLE MODELS

M185A3, M109A3

#### MATERIALS/PARTS

Twenty-four lockwashers

#### PERSONNEL REQUIRED

Two

#### REFERENCES (TM)

TM 9-2320-361-10

TM 9-2320-361-20P

#### EQUIPMENT CONDITION

Parking brake set (TM 9-2320-361-10).

#### **a. Compressor Removal**

1. Remove two wingnuts (14), washers (15), and lockwashers (16) from compressor mounting base (12). Discard lockwashers (16).
2. Remove wingnut (2), lockwasher (1), screw (4), ground strap (3), and two lockwashers (1) from compressor mounting base (12) and angle (5). Discard lockwashers (1).
3. Remove top cabinet drawer (38) and three screws (7) from cabinet (6).
4. Remove compressor (13), three nuts (11), washers (10), lockwashers (9), and block (8) from cabinet (6). Discard lockwashers (9).

#### **b. Vice and Machine Swivel Base Removal**

Remove four nuts (39), lockwashers (40), screws (35), washers (37), and vice and machine swivel case (34) from table (20). Discard lockwashers (40).

#### **c. Fire Extinguisher Bracket Removal**

1. Remove fire extinguisher (36) from fire extinguisher mounting bracket (31).
2. Remove four nuts (29), washers (30), screws (17), lockwashers (18), and fire extinguisher mounting bracket (31) from van body wall (19). Discard lockwashers (18).

#### **d. Grinding Machine Removal**

Remove four wingnuts (27), lockwashers (28), screws (33), washers (32), and grinding machine (26) from table (20). Discard lockwashers (28).

#### **e. Drill and Stand Removal**

Remove four nuts (25), washers (24), screws (22), lockwashers (23), and drill and stand (21) from table (20). Discard lockwashers (23).

12-71. VAN BODY TOOL REPLACEMENT (Contd)

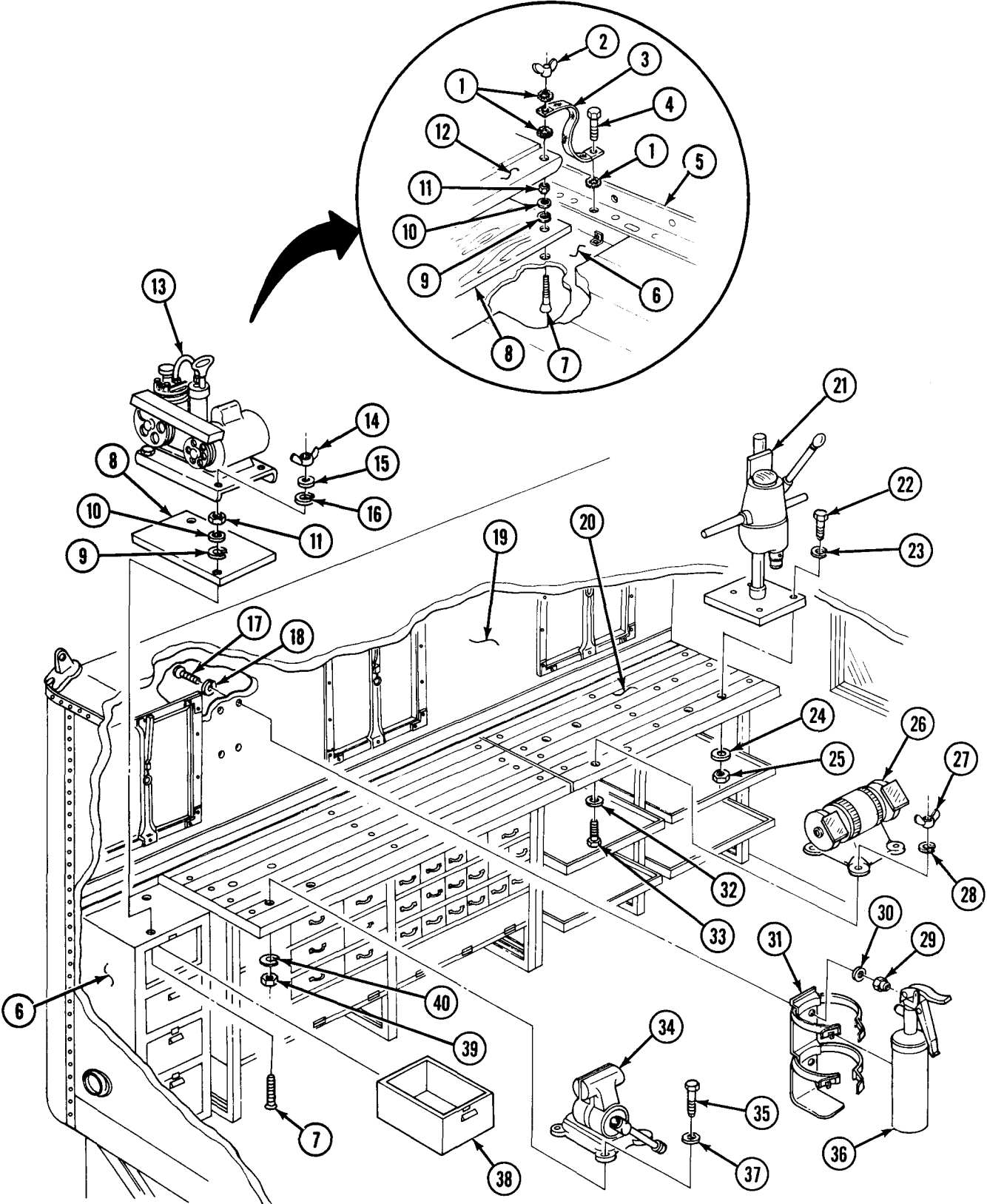

## 12-71. VAN BODY TOOL REPLACEMENT (Contd)

### f. Drill and Stand Installation

Install drill and stand (21) on table (20) with four new lock washers (23), screws (2), washers (24), and nuts (25).

### g. Grinding Machine Installation

Install grinding machine (26) on table (20) with four screws (33), washers (32), new lockwashers (28), and wingnuts (27).

### h. Fire Extinguisher Bracket Installation

#### NOTE

Assistant will help with step 1.

1. Install fire extinguisher mounting bracket (31) on van body wall (19) with four new lock-washers (18), screws (17), washers (30), and nuts (29).
2. Install fire extinguisher (36) on mounting bracket (31).

### i. Vice and Machine Swivel Base Installation

Install vice and machine swivel base (34) on table (20) with four washers (37), screws (35), new lockwashers (40), and nuts (39).

### j. Compressor Installation

1. Install block (8) and compressor (13) on cabinet (6) with three new lockwashers (9), washers (10), nuts (11).
2. Install top cabinet drawer (38) on cabinet (6) with three screws (7).
3. Install two new lockwashers (1), ground strap (3), new lockwasher (1), wingnut (2), and screw (4) on angle (5) and compressor mounting base (12).
4. Install two new lockwashers (16), washer (15), and wingnut (14) on compressor mounting base (12).

12-71. VAN BODY TOOL REPLACEMENT (Contd)

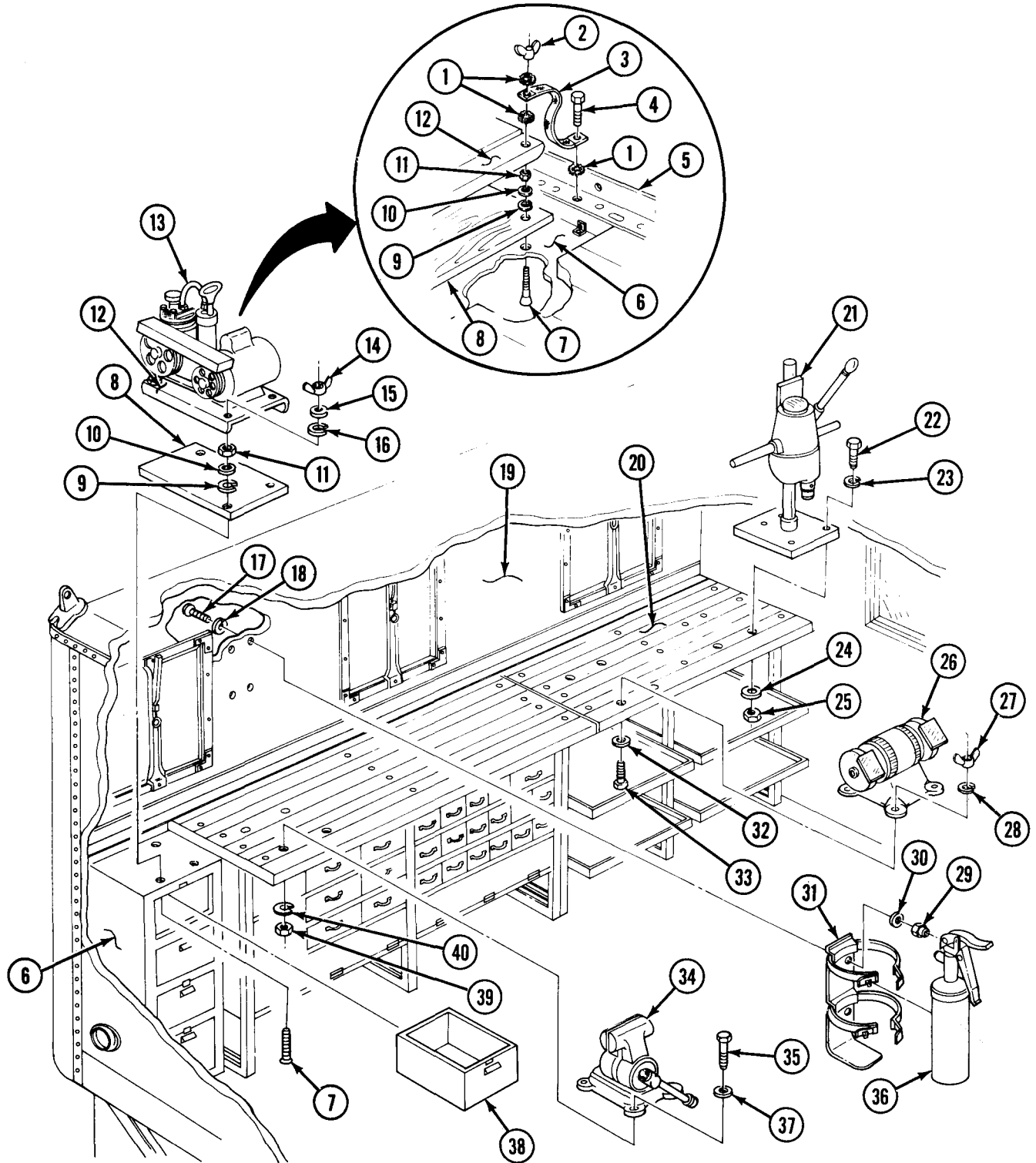

## 12-72. CONVERTER RECEPTACLE REPLACEMENT

This task covers:

- |  |   |
|--|---|
| a. 24-Volt Converter Receptacle Removal      | c. 115-Volt Converter Receptacle Removal      |
| b. 24-Volt Converter Receptacle Installation | d. 115-Volt Converter Receptacle Installation |

### INITIAL SETUP:

#### APPLICABLE MODELS

M185A3, M109A3

#### MATERIALS/PARTS

Four screw-assembled lockwashers

#### REFERENCES (TM)

TM 9-2320-361-20P

TM 9-237

#### EQUIPMENT CONDITION

Van body primary heater removed (para. 14-32).

### NOTE

Tag all wires for installation.

#### a. 24-Volt Converter Receptacle Removal

1. Remove socket (12) from receptacle (2).
2. Remove four screw-assembled lockwashers (1) and receptacle (2) from van wall (6). Discard screw-assembled lockwashers (1).
3. Pull back three insulation tubings (5) from three receptacle pins (3).
4. Unsolder and remove three wires (4) from three receptacle pins (3) (TM 9-237).

#### b. 24-Volt Converter Receptacle Installation

1. Insert three wires (4) into three receptacle pins (3) and solder in place (TM 9-237).
2. Install three insulation tubings (5) on three receptacle pins (3).
3. Install receptacle (2) on van wall (6) with four new screw-assembled lockwashers (1).
4. Install socket (12) on receptacle (2).

#### c. 115-Volt Converter Receptacle Removal

1. Remove plug (11) from receptacle (9).
2. Remove two screws (10) and receptacle (9) from van wall (6).
3. Remove two screws (7) and wires (8) from receptacle (9).

#### d. 115-Volt Converter Receptacle Installation

1. Install two wires (8) on receptacle (9) with two screws (7).
2. Install receptacle (9) on van wall (6) with two screws (10).
3. Install plug (11) on receptacle (9).

**12-72. CONVERTER RECEPTACLE REPLACEMENT (Contd)**

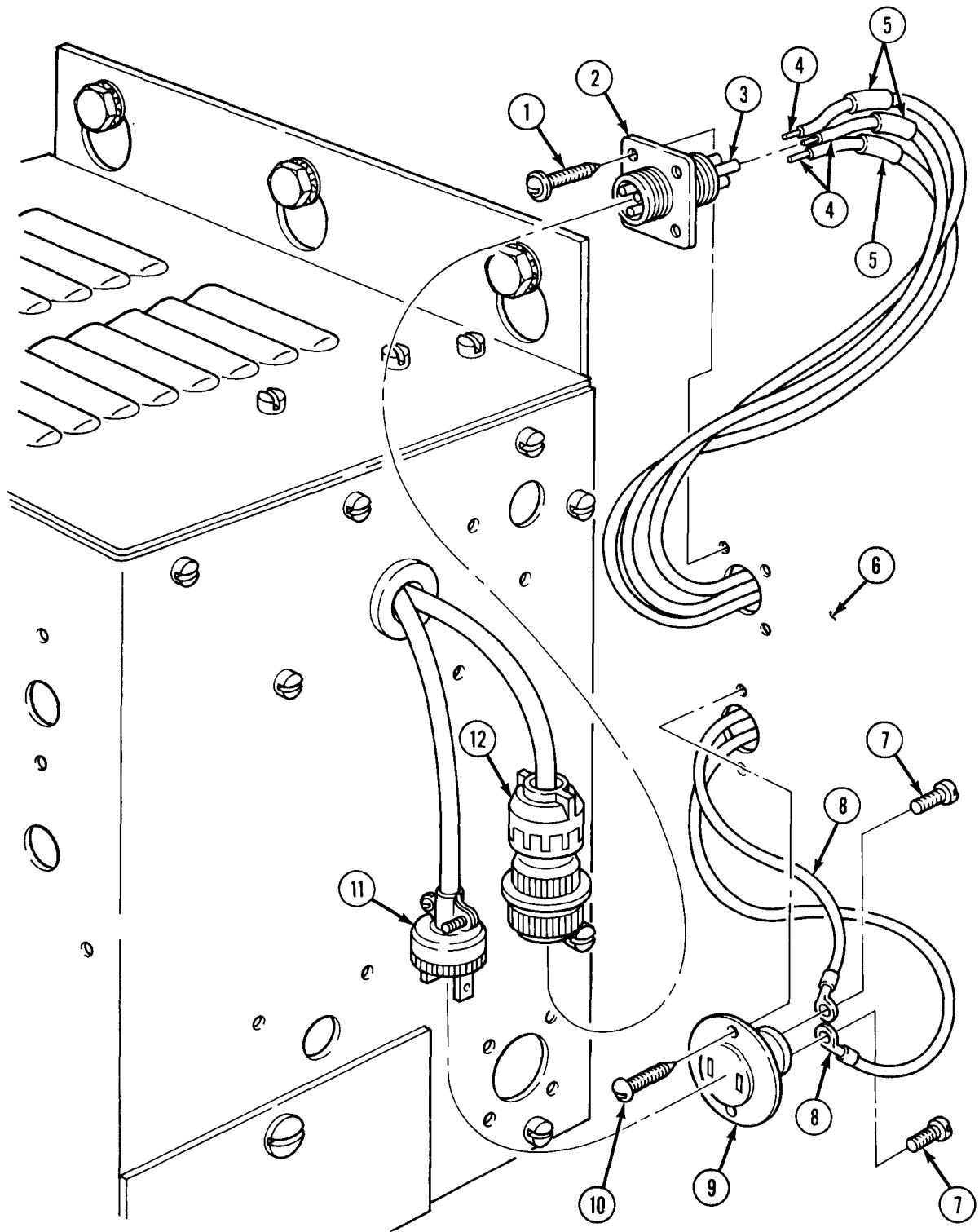

FOLLOW-ON TASK: Install van body primary heater (para. 14-32).

## 12-73. FLOODLIGHT BRACKET REPLACEMENT

This task covers:

a. Removal

b. Installation

INITIAL SETUP:

APPLICABLE MODELS  
M185A3, M109A3

REFERENCES (TM)  
TM 9-2320-361-20P

### NOTE

All brackets are removed and installed the same. This procedure covers two brackets.

#### a. Removal

1. Remove two screws (6) and bracket (1) from van roof (2).
2. Remove two screws (4) and bracket (5) from van wall (3).

#### b. Installation

1. Install bracket (5) on van wall (3) with two screws (4).
2. Install bracket (1) on van roof (2) with two screws (6).

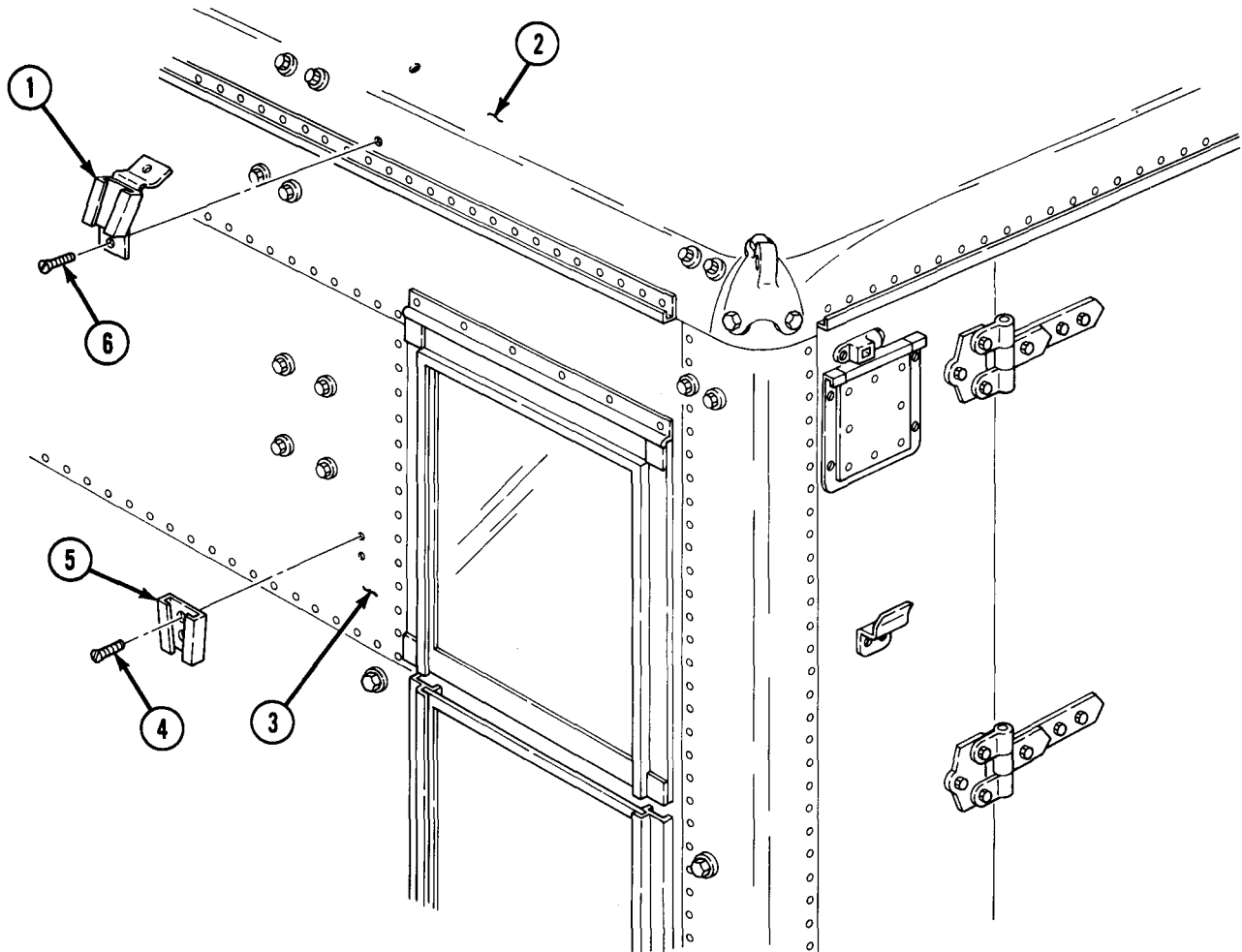

## 12-74. ACCESS DOOR MOULDING AND ACCESS PLATE REPLACEMENT

This task covers:

a. Removal

b. Installation

### INITIAL SETUP:

#### APPLICABLE MODELS

M185A3, M109A3

#### MATERIALS/PARTS

Three rivets

Three plugs

#### REFERENCES (TM)

TM 9-2320-361-10

TM 9-2320-361-20P

#### EQUIPMENT CONDITION

Parking brake set (TM 9-2320-361-10).

### a. Removal

1. Remove four screws (1) and plate (2) from van wall (3).
2. Drill three rivets (5) and plugs (6) out of moulding (4) and van wall (3). Discard rivets (5) and plugs (6).
3. Remove moulding (4) from van wall (3).

### b. Installation

1. Install moulding (4) on van wall (3) with three new rivets (5) and plugs (6).
2. Install plate (2) on van wall (3) with four screws (1).

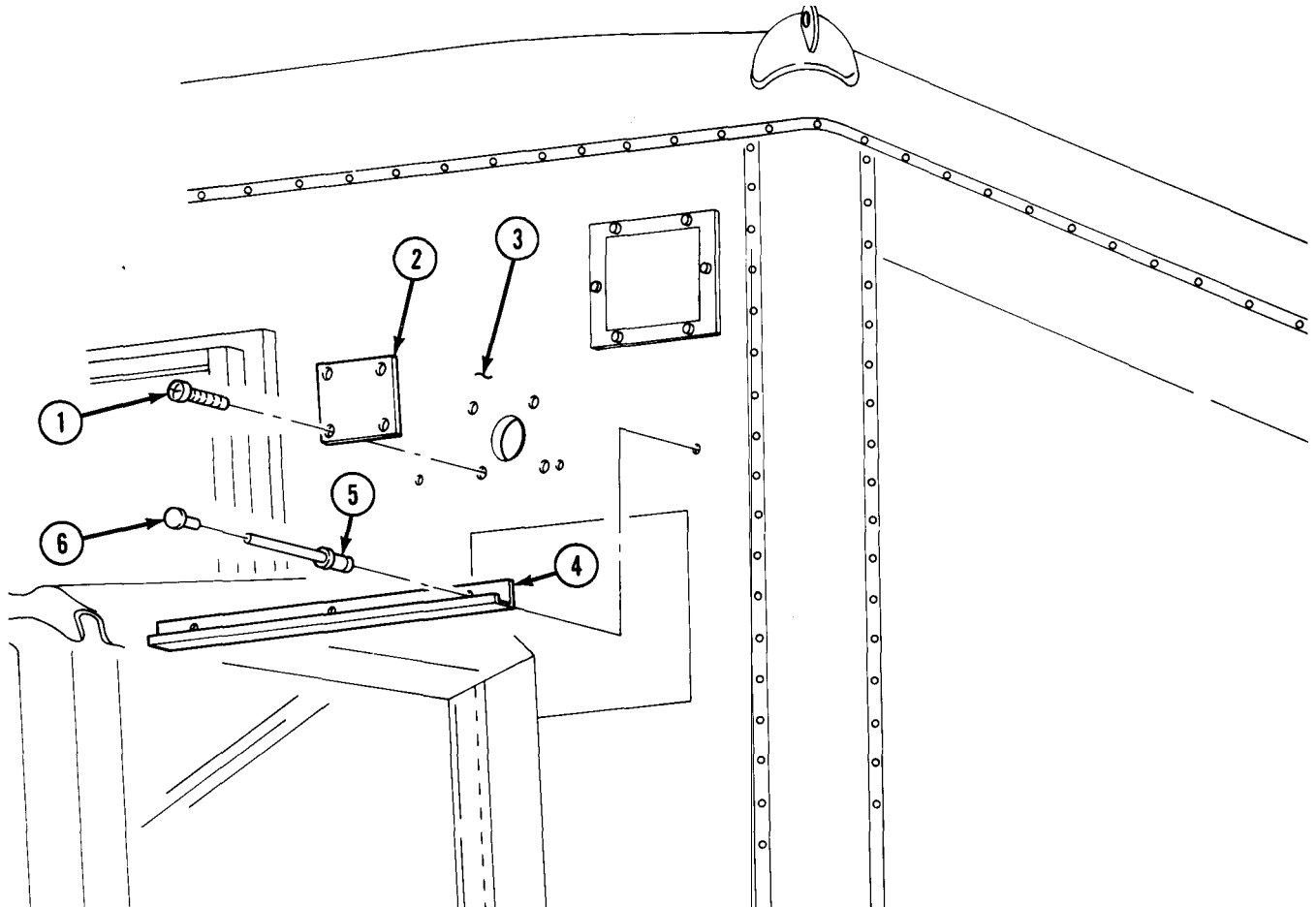



## 12-75. POWER SWITCH MAINTENANCE

This task covers:

- |  |  |
|--|--|
| <ul style="list-style-type: none"> <li>a. Removal</li> <li>b. Disassembly</li> </ul> | <ul style="list-style-type: none"> <li>c. Assembly</li> <li>d. Installation</li> </ul> |
|--|--|

### INITIAL SETUP:

**APPLICABLE MODELS**

M185A3, M109A3

**MATERIALS/PARTS**

Six lockwashers  
Two locking rings

**REFERENCES (TM)**

TM 9-2320-361-10  
TM 9-2320-361-20P

**EQUIPMENT CONDITION**

- Parking brake set (TM 9-2320-361-10).
- Battery ground cable disconnected (para. 4-48)

NOTE

Tag all wires and terminals for installation.

1. Remove four screws (1) and power switch cover (3) from van body (2).
2. Remove two screws (9), lockwashers (8), and wires (4) and (10) from switch (11). Discard lockwashers (8).
3. Remove two screws (7), lockwashers (6), and wires (4), (5), (12) and (13) from switch (14). Discard lockwashers (6).

**b. Disassembly**

1. Remove two nuts (18), lockwashers (17), and power switch cover (3) from switches (11) and (14). Discard lockwashers (17).
2. Remove two locking rings (15) and nuts (16) from switches (11) and (14). Discard locking rings (16).

**c. Assembly**

1. Install two nuts (16) and new locking rings (15) on switches (14) and (11).
2. Install switches (14) and (11) on power switch cover (3) with two new lockwashers (17) and nuts (18).

**d. Installation**

1. Install wires (4), (5), (12), and (13) on switch (14) with two new lockwashers (6) and screws (7).
2. Install wires (4) and (10) on switch (11) with two new lockwashers (8) and screws (9).
3. Install power switch cover (3) on van body (2) with four screws (1).

**12-75. POWER SWITCH MAINTENANCE (Contd)**

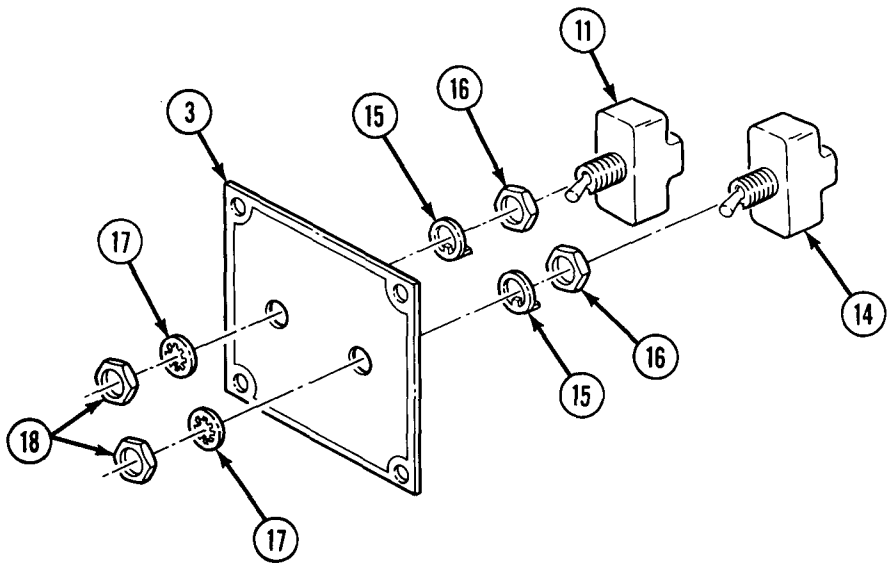
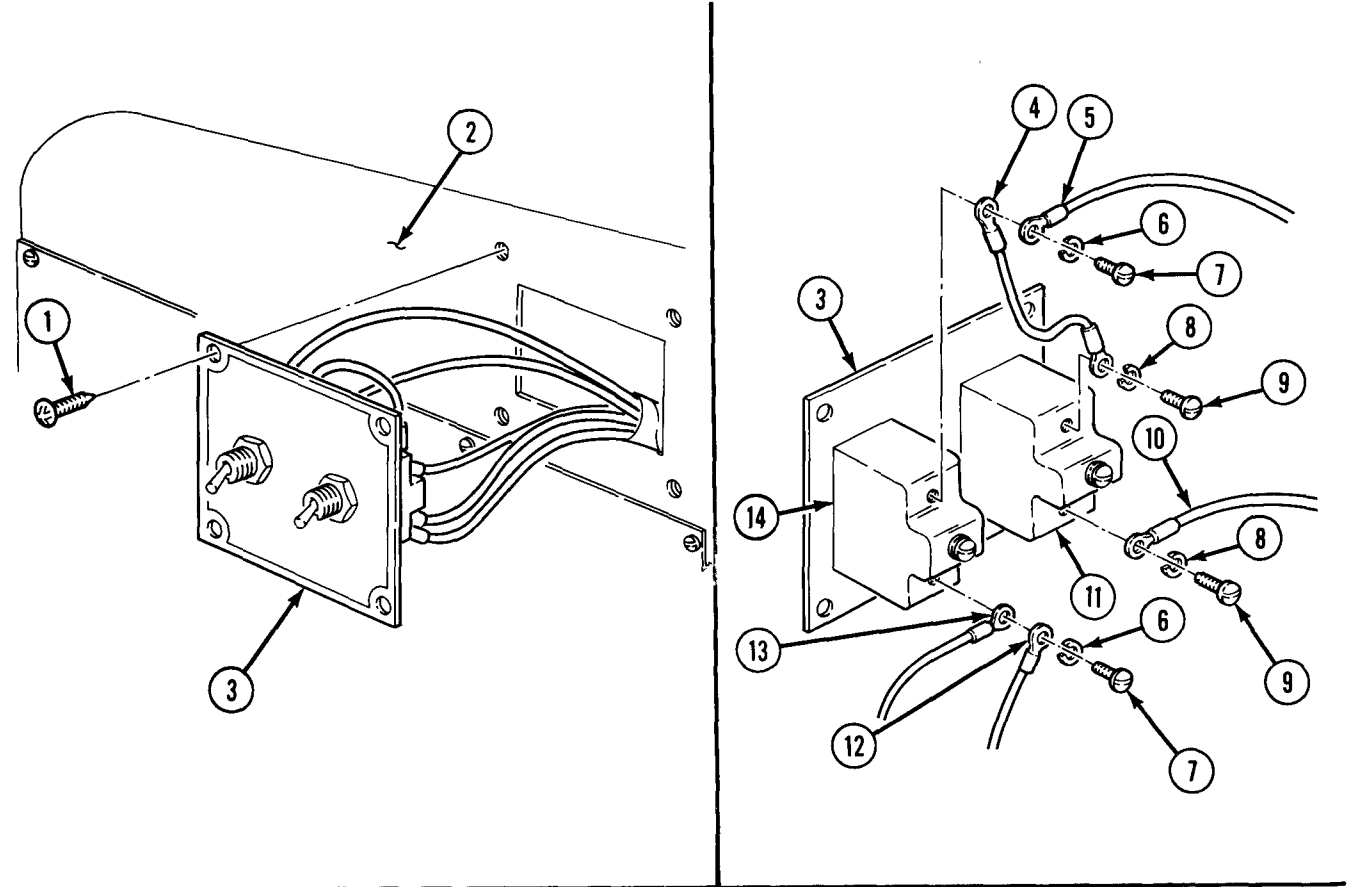

FOLLOW-ON TASK. Connect battery ground cable (para. 4-48).

**12-76. DOOR HOLDER ASSEMBLY AND BRACKET REPLACEMENT**

This task covers:

a. Removal

b. Installation

INITIAL SETUP:

APPLICABLE MODELS  
M185A3, M109A3

REFERENCES (TM)  
TM 9-2320-361-10  
TM 9-2320-361-20P

MATERIALS/PARTS  
Twelve lockwashers

EQUIPMENT CONDITION  
Parking brake set (TM 9-2320-361-10).

**a. Removal**

1. Remove four screws (5), lockwashers (4), door holder (3) from van wall (2). Discard lockwashers (4).
2. Remove four screws (7), lockwashers (6), and catch (8) from bracket (11). Discard lockwashers (6).
3. Remove four screws (9), lockwashers (10), and bracket (11) from van door (1). Discard lockwasher (10).

**b. Installation**

1. Install bracket (11) on van door (1) with four new lockwashers (10) and screws (9).
2. Install catch (8) on bracket (11) with four new lockwashers (6) and screws (7).
3. Install door holder (3) on van wall (2) with four new lockwashers (4) and screws (5).

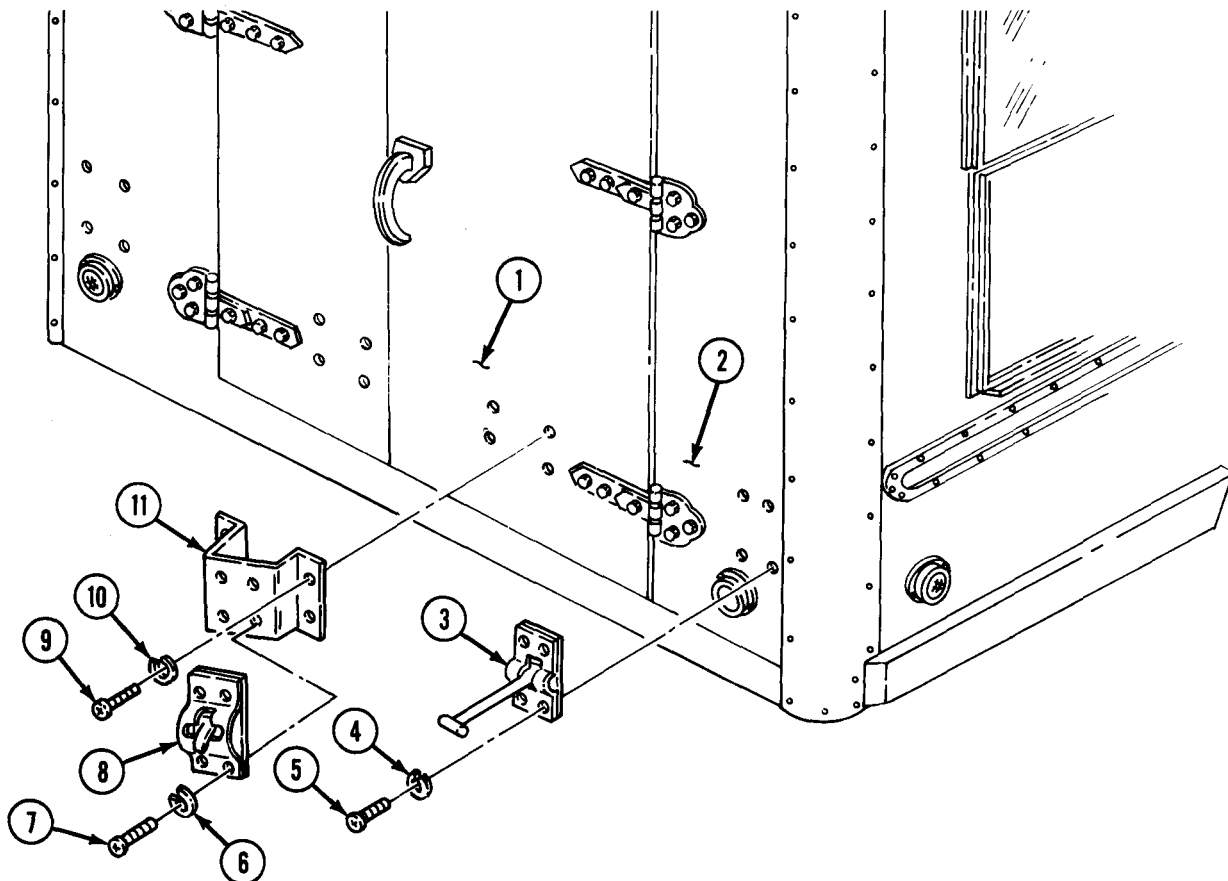

## 12-77. DOOR CHECK REPLACEMENT

This task covers:

### a. Removal

### b. Installation

#### INITIAL SETUP:

##### APPLICABLE MODELS

M185A3, M109A3

##### REFERENCES (TM)

TM 9-2320-361-10

TM 9-2320-361-20P

##### MATERIALS/PARTS

Two locknuts

Adhesive (Appendix C, Item 2)

##### EQUIPMENT CONDITION

Parking brake set (TM 9-2320-361-10).

#### NOTE

Left and right door checks are removed and installed the same. This procedure covers the right door check.

### a. Removal

1. Pull back door seal (3) from door channel (5).
2. Remove two locknuts (7), screws (6), and door check (1) from door channel (5). Discard locknuts (7).
3. Remove two screws (2) and door check (1) from van door (4).

### b. Installation

1. Install door check (1) on van door (4) with two screws (2).
2. Install door check (1) on door channel (5) with two new lockwashers (7) and screws (6).
3. Apply adhesive to door channel (5) and place door seal (3) on door channel (5).

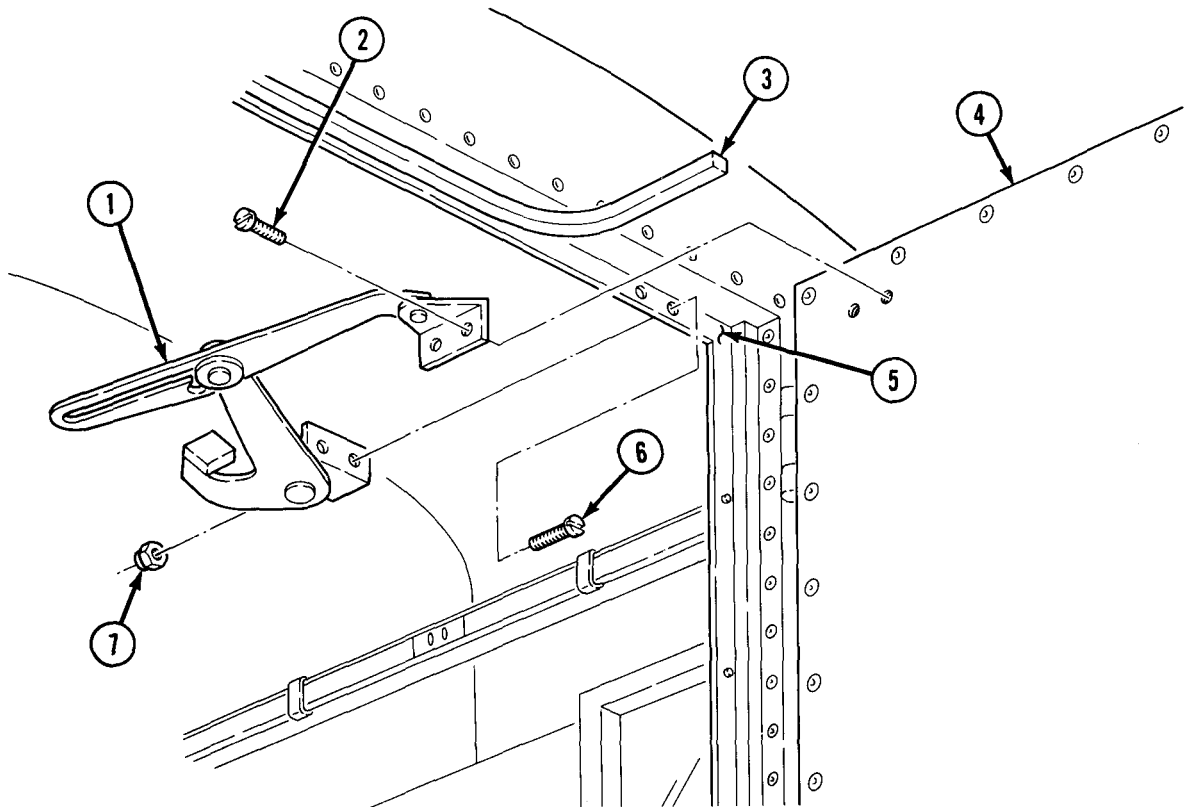

## 12-78. EXHAUST BLOWER DUCT ASSEMBLY REPLACEMENT

This task covers:

a. Removal

b. Installation

INITIAL SETUP:

**APPLICABLE MODELS**

M185A3, M109A3

**EQUIPMENT CONDITION**

Exhaust blower motor and bracket removed (para. 12-60).

**REFERENCES (TM)**

TM 9-2320-361-20P

### a. Removal

1. Remove four screws (1) and adapter (3) from duct assembly (2).
2. Remove eight screws (5) and four angles (4) from van wall (7).
3. Remove four screws (6) and duct assembly (2) from van wall (7).

### b. Installation

1. Install duct assembly (2) on van wall (7) with four screws (6).
2. Install four angles (4) on van wall (7) with eight screws (5).
3. Install adapter (3) on duct assembly (2) with four screws (1).

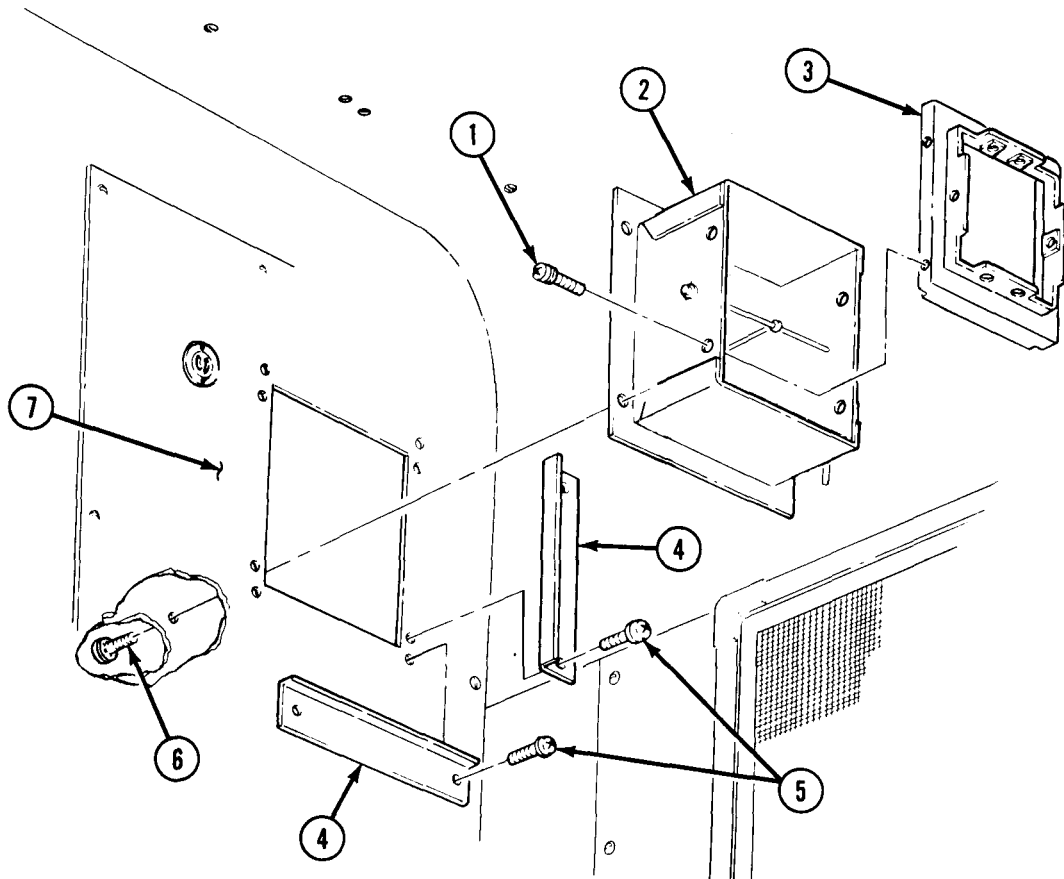

FOLLOW-ON TASK: Install exhaust blower motor and bracket (para. 12-60).

## 12-79. BLOWER MOTOR RECEPTACLE REPLACEMENT

This task covers:

a. Removal

b. Installation

INITIAL SETUP:

### APPLICABLE MODELS

M185A3, M109A3

### MATERIALS/PARTS

Two lockwashers

### REFERENCES (TM)

TM 9-2320-361-10

TM 9-2320-361-20P

### EQUIPMENT CONDITION

Parking brake set (TM 9-2320-361-10).

### a. Removal

1. Remove two screws (3) from blower motor receptacle (4) and van wall (1).
2. Pull receptacle forward and remove two screws (6), lockwashers (5), and wires (2) from blower motor receptacle (4). Discard lockwashers (5).

### b. Installation

1. Install two wires (2) on blower-motor receptacle (4) with two screws (6) and new lockwashers (5).
2. Install blower motor receptacle (4) on van wall (1) with two screws (3).

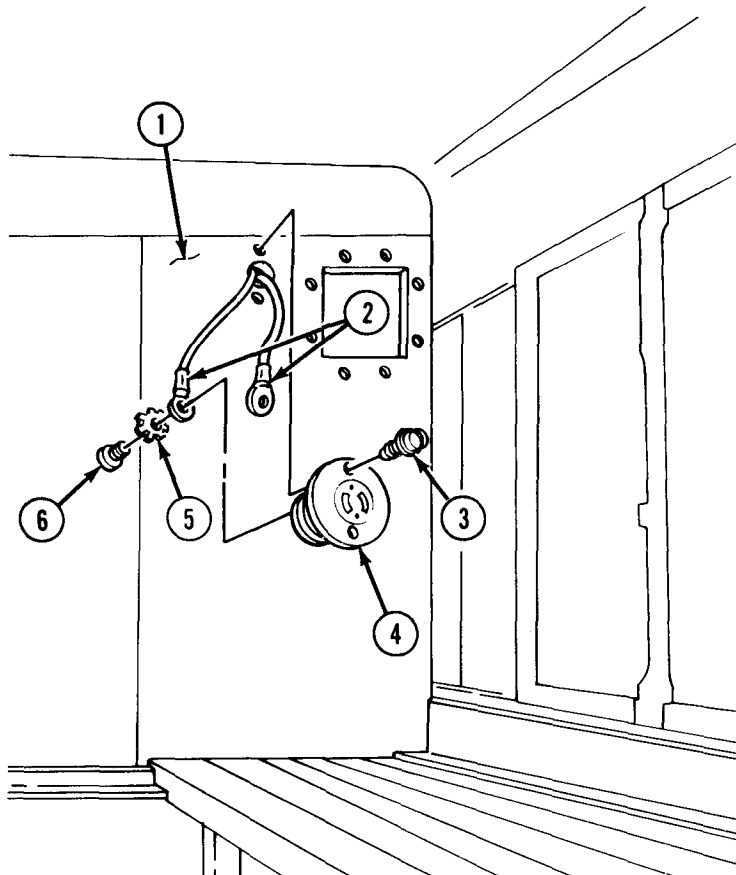

## 12-80. BLACKOUT SWITCH MAINTENANCE

This task covers:

- a. Removal
- b. Disassembly
- c. Assembly
- d. Installation

### INITIAL SETUP:

#### APPLICABLE MODELS

M185A3, M109A3

#### MATERIALS/PARTS

Four lockwashers

#### REFERENCES (TM)

TM 9-2320-361-10

TM 9-2320-361-20P

#### EQUIPMENT CONDITION

Parking brake set (TM 9-2320-361-10).

### NOTE

Tag all wires for installation.

#### **a. Removal**

1. Remove four screws (6) and cover (5) from van body (1).
2. Remove four screws (4), lockwashers (3), two wires (2), and wires (11) from two switches (10). Discard lockwashers (3).
3. Remove four screws (8) and bracket (9) from van body (1).

#### **b. Disassembly**

Remove two nuts (7) and switches (10) from bracket (9).

#### **c. Assembly**

Install two switches (10) on bracket (9) with two nuts (7).

#### **d. Installation**

1. Install bracket (9) on van body (1) with four screws (8).
2. Install two wires (2) and wires (11) on two switches (10) with four new lockwashers (3) and screws (4).
3. Install cover (5) on van body (1) with four screws (6).

**12-80. BLACKOUT SWITCH MAINTENANCE (Contd)**

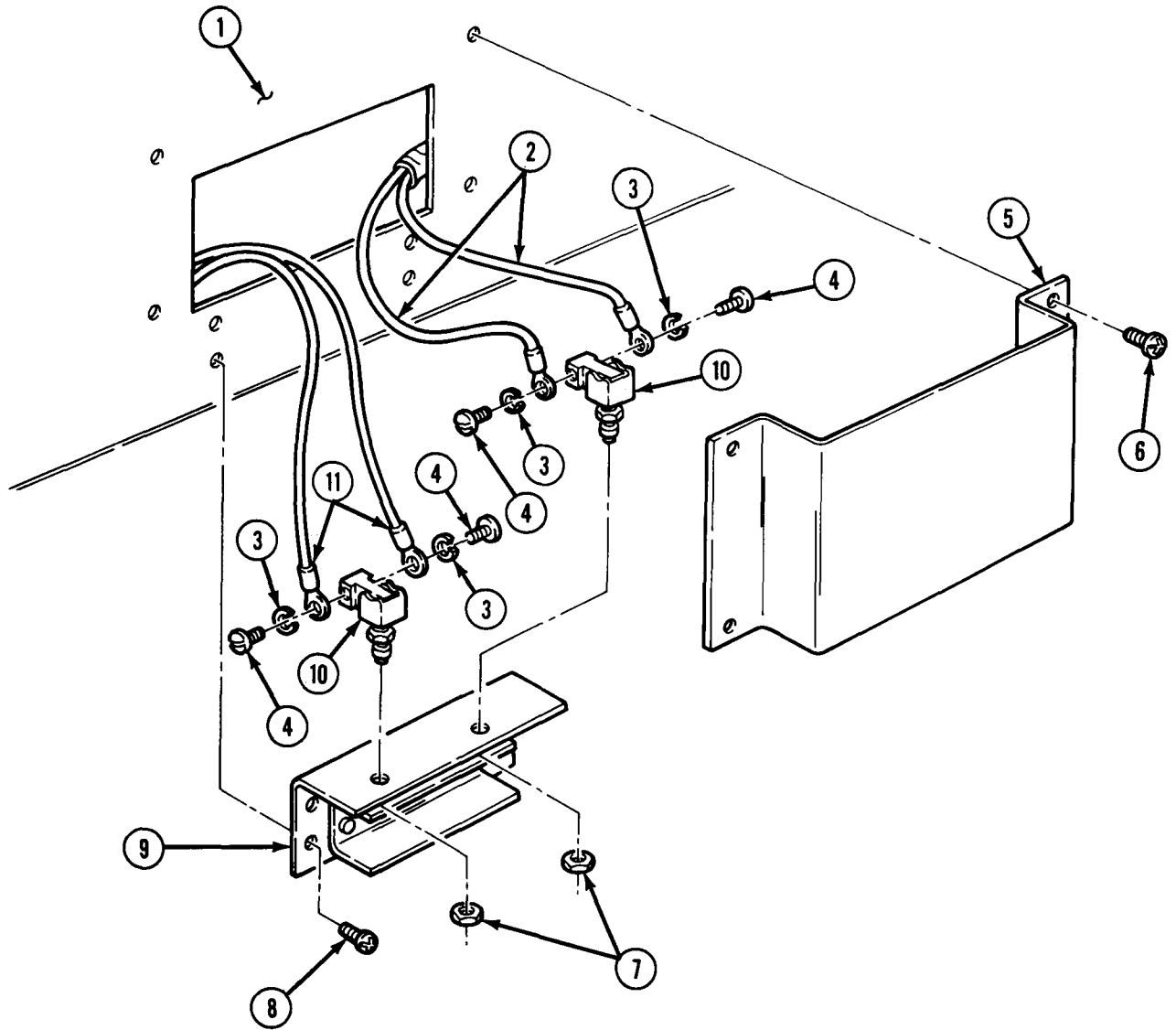



# 12-81. FUEL LINE ADAPTER REPLACEMENT

This task covers:

a. Removal

b. Installation

INITIAL SETUP:

APPLICABLE MODELS

M185A3, M109A3

EQUIPMENT CONDITION

Parking brake set (TM 9-2320-361-10).

REFERENCES (TM)

TM 9-2320-361-10

TM 9-2320-361-20P

## a. Removal

1. Remove three screws (1) and fuel line adapter (4) from van body front wall (2).
2. Remove two plugs (3) from fuel line adapter (4).

## b. Installation

1. Install two plugs (3) in fuel line adapter (4).
2. Install fuel line adapter (4) in van body front wall (2) with three screws (1).

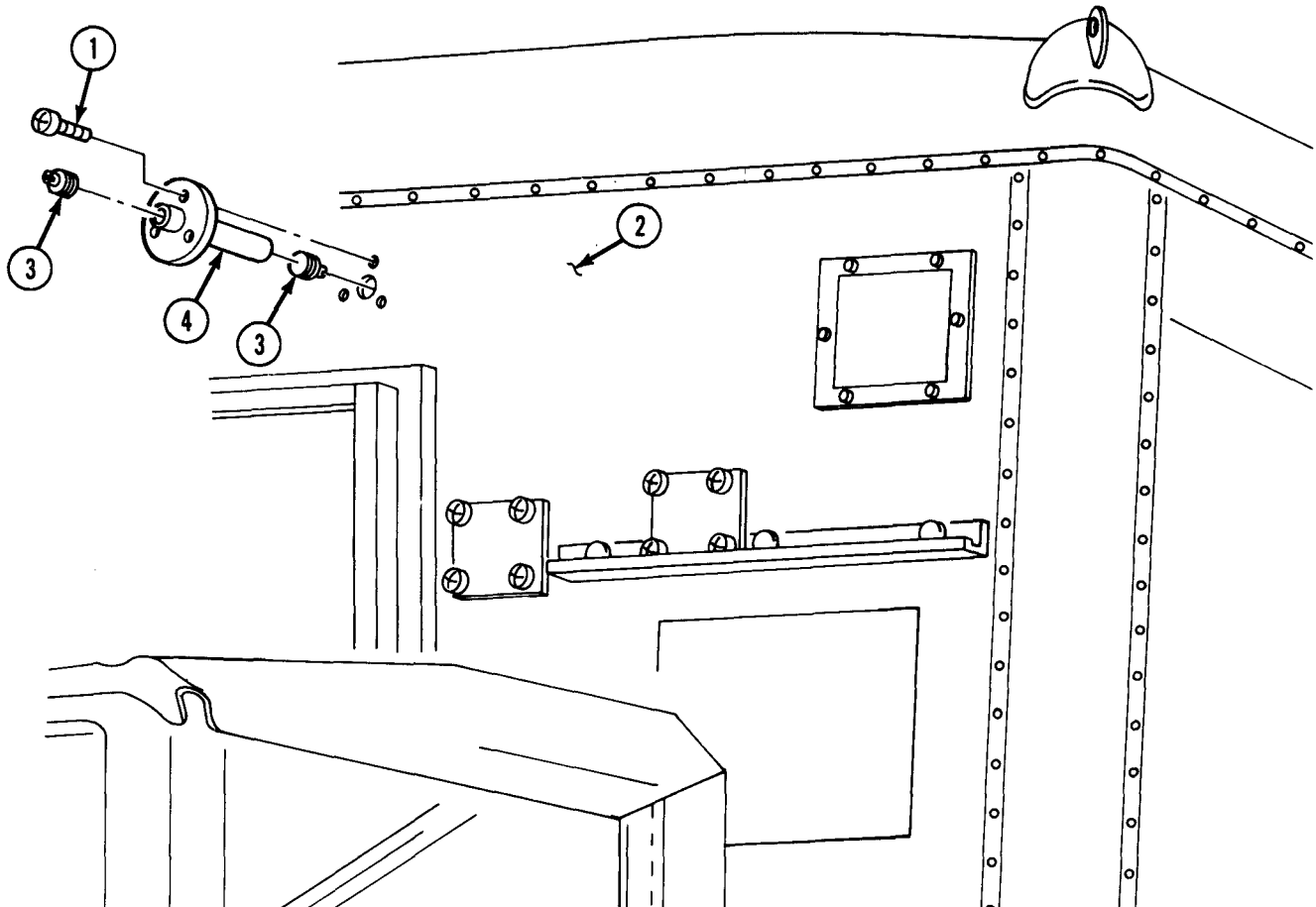

## 12-82. SIDE RAIL MAINTENANCE

This task covers:

- a. Removal
- b. Cleaning

c. Installation

INITIAL SETUP:

### APPLICABLE MODELS

M185A3, M109A3

### MATERIAL/PARTS

Fifty-four rivets  
Fifty-four plugs  
Tar (Appendix C, Item 29)

### REFERENCES (TM)

TM 9-2320-361-10  
TM 9-2320-361-20P

### EQUIPMENT CONDITION

Parking brake set (TM 9-2320-361-10).

### NOTE

Side rails on both sides of van body are removed and installed the same. This task covers one side.

### a. Removal

1. Drill fifty-four plugs (3) and rivets (2) out of side rail (4) and van wall (1).
2. Remove two side rails (4) from van wall (1).

### b. Cleaning

Clean all tar out of rivet holes (5) and side rail (4).

### c. Installation

### NOTE

A sealer coat of hot tar must be applied to inside of rail in area of rivet holes before installation.

Install two side rails (4) on van wall (1) with fifty-four new rivets (2) and plugs (3).

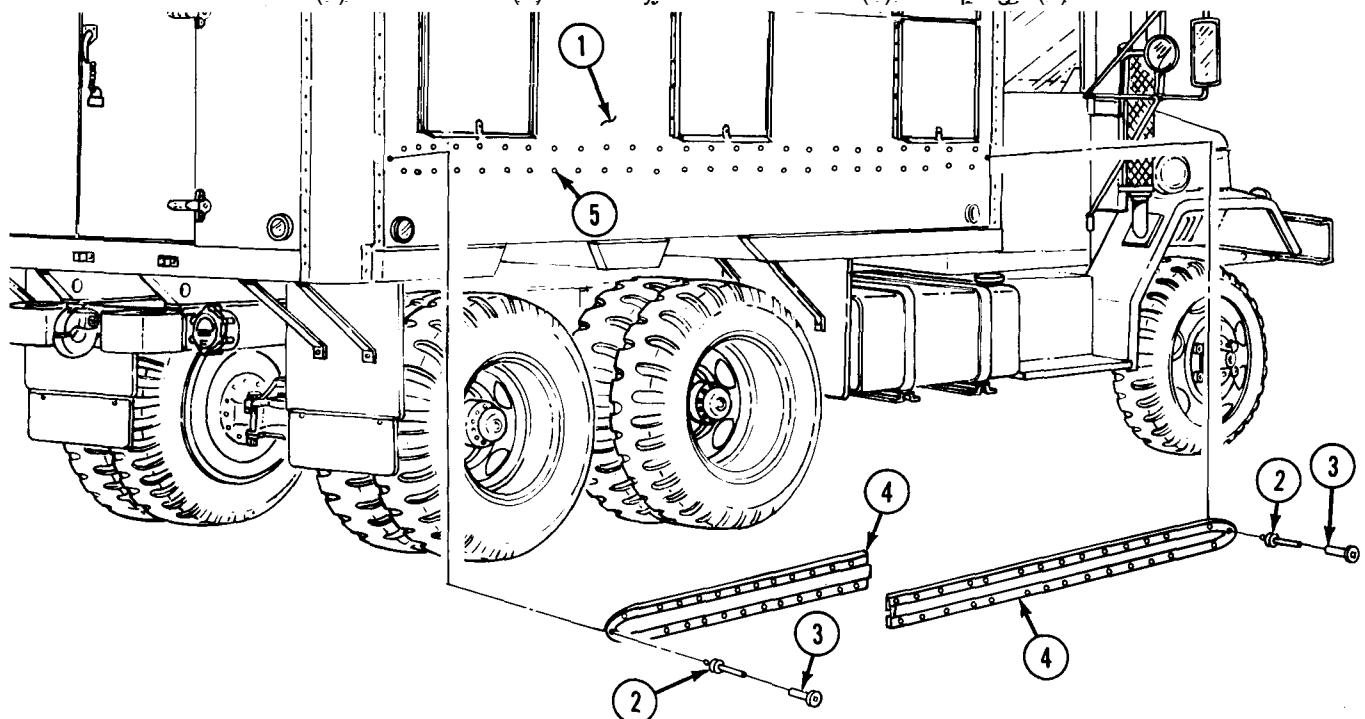

Section V. EARTH BORING AND POLESETTING TRUCK BODY MAINTENANCE

**12-83. EARTH BORING AND POLESETTING TRUCK BODY MAINTENANCE INDEX**

PARA. NO.	TITLE	PAGE NO.
12-84.	Cab Protector Replacement (M764)	12-132
12-85.	Horizontal Leveling Worm Drivechain Replacement	12-136
12-86.	Vertical Leveling Worm Drivechain Replacement	12-138
12-87.	Leveling Worm Cover and Drivechain Maintenance	12-140
12-88.	Hydraulic Oil Level Gage and Screen Replacement	12-143
12-89.	Earth Boring Machine Propeller Shaft Maintenance	12-144
12-90.	Hydraulic Pump Universal Joint Maintenance	12-146
12-91.	Outrigger Hydraulic Lines Replacement	12-148
12-92.	Earth Boring Machine Seat Frame & placement	12-154
12-93.	Earth Boring Machine Seat and Backrest Cushion Replacement	12-155
12-94.	Collapsible Cable Reel Disassembly	12-156
12-95.	Hydraulic Tank Replacement	12-158
12-96.	Operation Levers Maintenance	12-160
12-97.	Snatch Sheave Maintenance	12-162
12-98.	Snatch Sheave Replacement	12-164

**12-84. CAB PROTECTOR REPLACEMENT (M764)**

This task covers:

- |   |   |
|---|---|
| <p>a. Cab Protector Removal<br/>b. Mounting Tubes Removal</p> | <p>c. Mounting Tubes Installation<br/>d. Cab Protector Installation</p> |
|---|---|

**INITIAL SETUP:**

APPLICABLE MODELS

M764

MATERIAL/PARTS

- Eight locknuts
- Four lockwashers
- Saddle webbing
- Adhesive (Appendix C, Item 3)

PERSONNEL REQUIRED

Two

REFERENCES (TM)

- TM 9-2320-361-10
- TM 9-2320-361-20P

EQUIPMENT CONDITION

- Parking brake set (TM 9-2320-361-10).
- Raise derrick (TM 9-2320-361-10).

GENERAL SAFETY INSTRUCTIONS

All personnel must stand clear during lifting operations.

## 12-84. CAB PROTECTOR REPLACEMENT (M764) (Contd)

### a. Cab Protector Removal

1. Remove four upper pins (11) from cab protector (4) and tubes (10).
2. Secure chain sling (1) to cab protector (4) and lifting device (2).

### WARNING

Personnel must stand clear during lifting operations. A swinging or shifting load may result in injury to personnel.

### NOTE

Assistant will help with step 3.

3. Remove cab protector (4) from four tubes (10) with lifting device (2) and lower cab protector (4) to ground. Remove chain sling (1) from cab protector (4).
4. Remove four wingnuts (16), screws (15), hoses (12), two straps (13), and four washers (14) from cab protector (4).
5. Remove four nuts (9), lockwashers (8), screws (7), and two straps (6) from chock block holder (5).
6. Inspect saddle webbing (3) for tears, rips, or missing sections. If damaged, remove from cab protector (4). Scrape remains of saddle webbing (3) and sealer from cab protector (4).

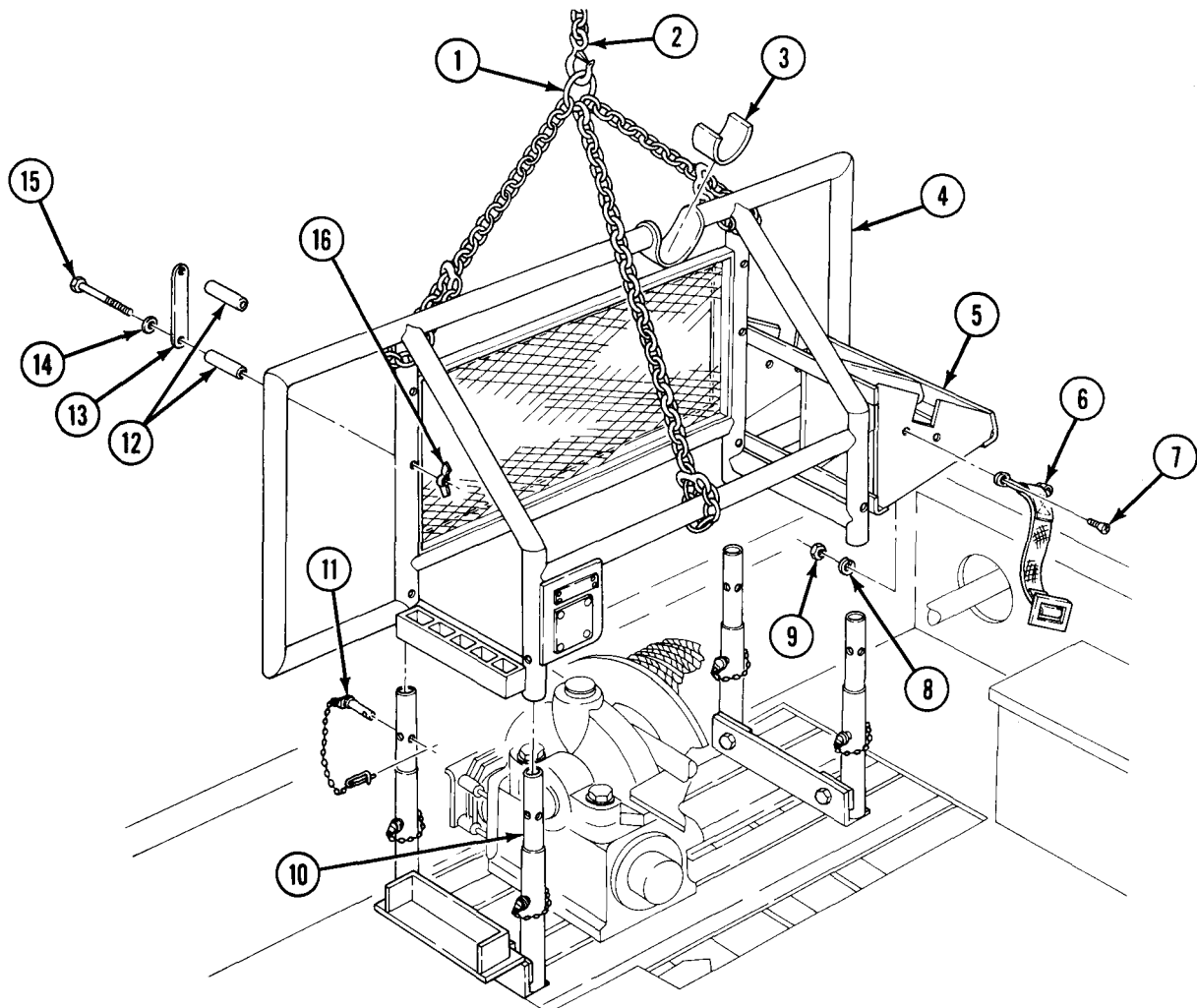

## 12-84. CAB PROTECTOR REPLACEMENT (M764) (Contd)

### b. Mounting Tubes Removal

1. Remove four pins (10) and tubes (11) from mounting tubes (4).
2. Remove four locknuts (1), screws (5), cargo bracket (9), and four mounting tubes (4) from two angle brackets (3). Discard locknuts (1).
3. Remove four locknuts (7), level washers (6), screws (2), and two angle brackets (3) from frame (8). Discard locknuts (7).

### c. Mounting Tubes Installation

1. Install two angle brackets (3) on frame (8) with four screws (2), bevel washers (6), and new locknuts (7).
2. Install cargo bracket (9) and four mounting tubes (4) on two angle brackets (3) with four screws (5) and new locknuts (1).
3. Install four tubes (11) into four mounting tubes (4).
4. Install four pins (10) through mounting tubes (4) and tubes (11).

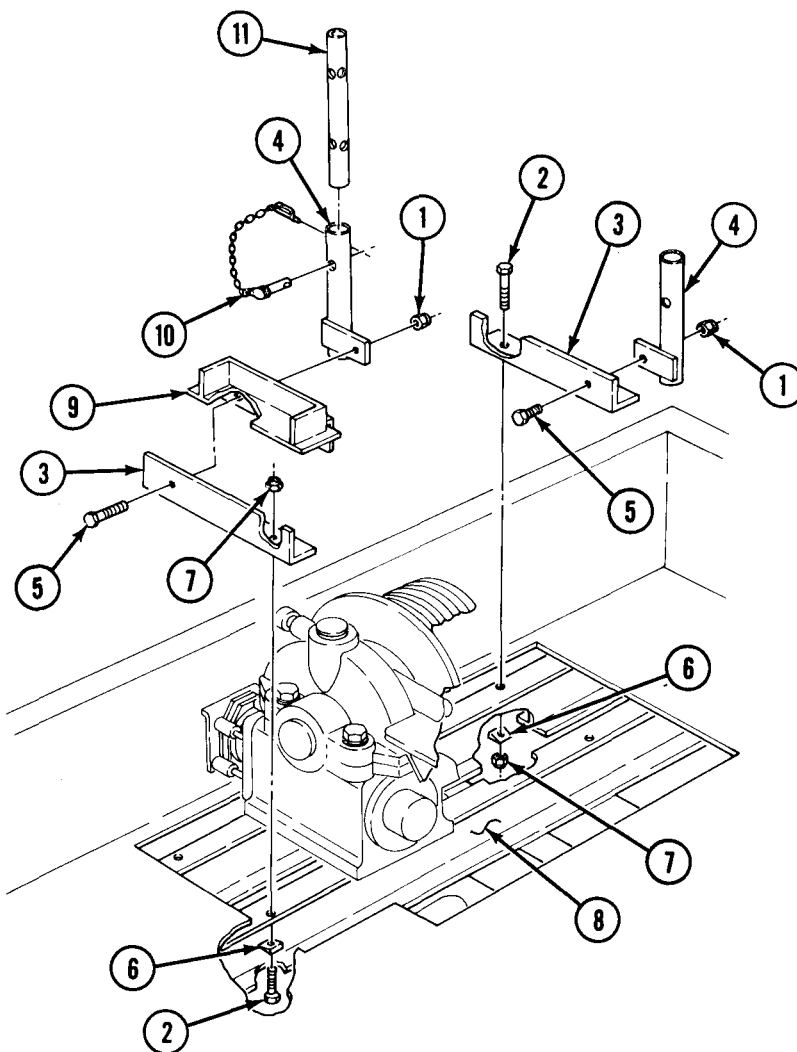

**12-84. CAB PROTECTOR REPLACEMENT (M764) (Contd)**

**d. Cab Protector Installation**

**NOTE**

Perform step 1 if saddle webbing was removed.

1. Install new saddle webbing (14) on cab protector (15) with adhesive.
2. Install two straps (17) on chock block holder (16) with four screws (18), new lockwashers (19), and nuts (20).
3. Install four hoses (21), two straps (22), four washers (23), screws (24), and wingnuts (25) on cab protector (15).

**WARNING**

Personnel must stand clear during lifting operations. A swinging or shifting load may cause injury to personnel.

**NOTE**

Assistant will help with step 4.

4. Install chain sling (12) on cab protector (15) and lifting device (13) and lift cab protector (15) onto four tubes (11).
5. Install four upper pins (10) through cab protector (15) and four tubes (11).

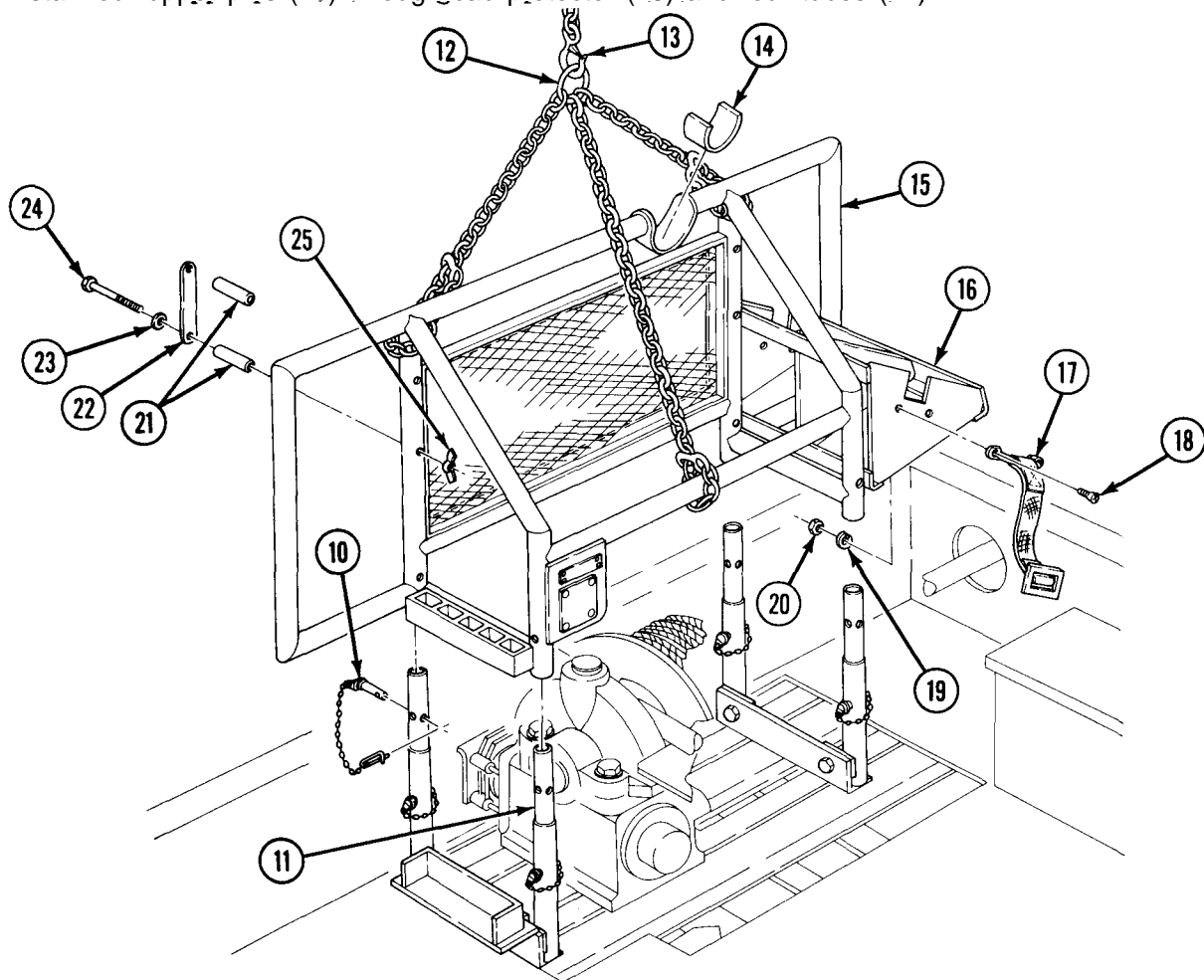

FOLLOW-ON TASK: Lower derrick to stowed position (TM 9-2320-361-10).

## 12-85. HORIZONTAL LEVELING WORM DRIVECHAIN REPLACEMENT

This task covers:

**a. Removal**

**b. Installation**

**INITIAL SETUP:**

**APPLICABLE MODELS**

M764

**REFERENCES (TM)**

TM 9-2320-361-10

TM 9-2320-361-20P

**EQUIPMENT CONDITION**

- Parking brake set (TM 9-2320-361-10).
- Horizontal drivechain cover removed (para. 12-87).

**NOTE**

- The replacement procedure for first and second reduction leveling worm drivechains are the same. This procedure covers the second reduction drivechain.
- Horizontal leveling worm drivechain may have cotter pins or a spring clip fastener for a retainer. This procedure covers a spring clip.

**a. Removal**

1. Loosen nut (3) and screw (2).
2. Hold shaft (4), and turn eccentric bushing (5) until first and second reduction drivechains (6) and (1) are loose.
3. Remove spring clip (11) and link plate (10) from connecting link (9).
4. Remove connecting link (9) from second reduction drivechain (1) and remove second reduction drivechain (1) from sprockets (7) and (8).

**b. Installation**

1. Install second reduction drivechain (1) on sprockets (7) and (8) and install connecting link (9) on second reduction drivechain (1).
2. Install link plate (10) and spring clip (11) on connecting link (9).
3. Hold shaft (4) and turn eccentric bushing (5) until first and second reduction drive chains (6) and (1) are tight.
4. Tighten nut (3) and screw (2).

**12-85. HORIZONTAL LEVELING WORM DRIVECHAIN REPLACEMENT (Contd)**

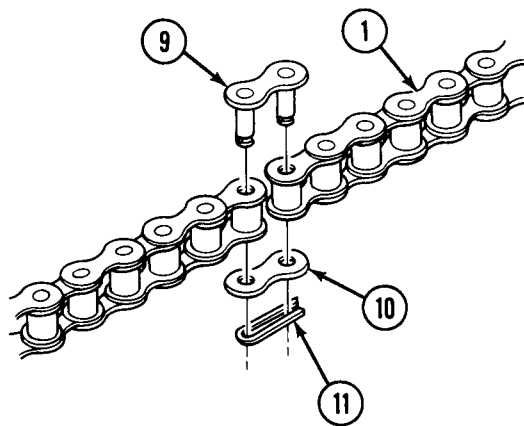
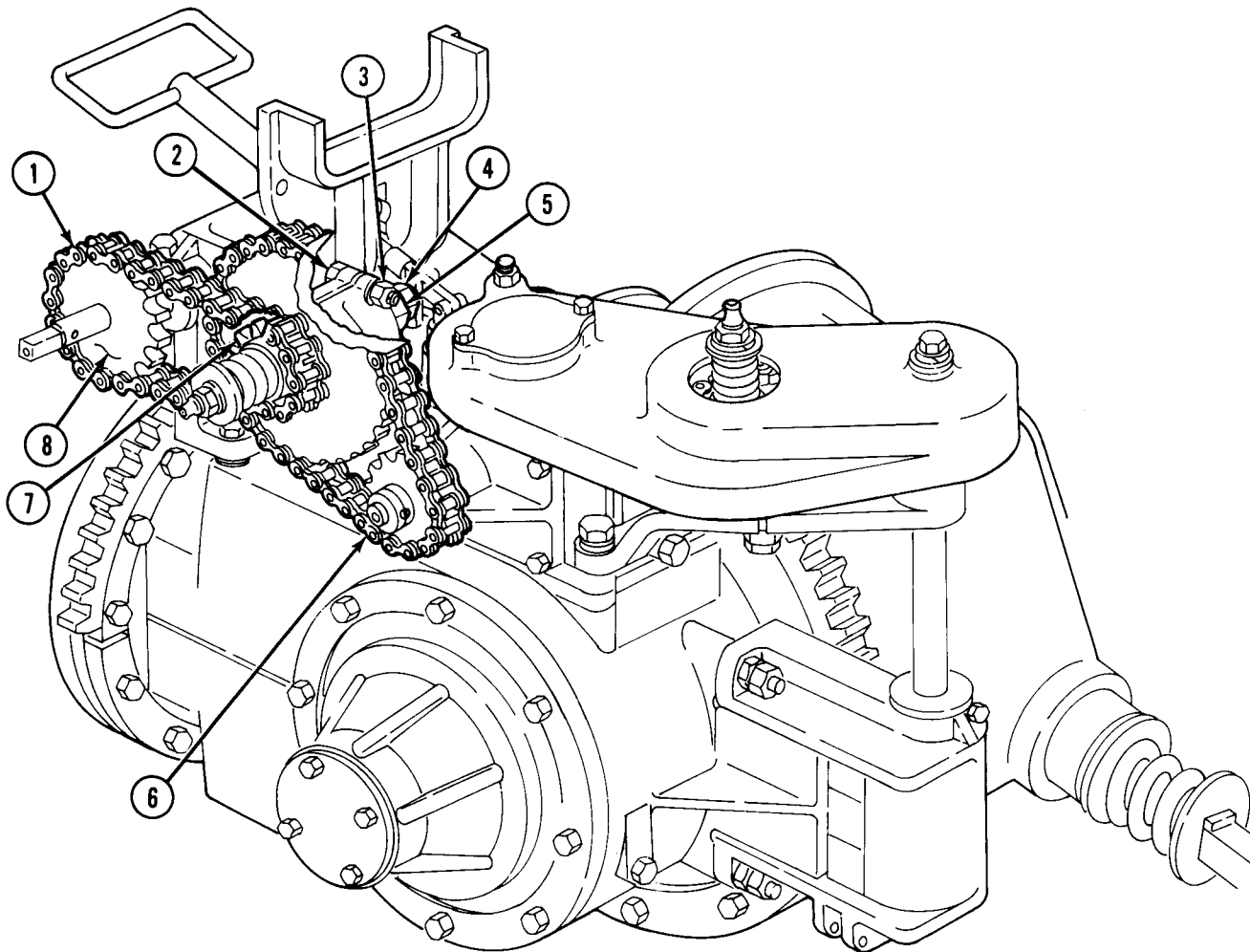

FOLLOW-ON TASK: Adjust horizontal drivechain and install cover (para. 12-87).



## 12-86. VERTICAL LEVELING WORM DRIVECHAIN REPLACEMENT

This task covers:

**a. Removal**

**b. Installation**

**INITIAL SETUP:**

**APPLICABLE MODELS**

M764

**REFERENCES (TM)**

TM 9-2320-361-10

TM 9-2320-361-20P

**EQUIPMENT CONDITION**

- Parking brake set (TM 9-2320-361-10).
- Vertical drivechain cover removed (para. 12-87).

**NOTE**

- The replacement procedure for first and second reduction leveling worm drivechains are the same. This procedure covers second reduction drivechain.
- Vertical leveling worm drivechain may have cotter pins or a spring clip fastener for a retainer. This procedure covers a spring clip fastener.

**a. Removal**

1. Loosen nut (5) and screw (8).
2. Hold shaft (7) and turn eccentric bushing (6) until first and second reduction drivechains (1) and (4) are loose.
3. Remove spring clip (11) and link plate (10) from connecting link (9).
4. Remove connecting link (9) from second reduction drivechain (4) and remove second reduction drivechain (4) from sprockets (2) and (3).

**b. Installation**

1. Install second reduction drivechain (4) on sprockets (2) and (3) and install connecting link (9) on second reduction drivechain (4).
2. Install link plate (10) and spring clip (11) on connecting link (9).
3. Hold shaft (7) and turn eccentric bushing (6) until first and second reduction drivechains (4) and (1) are tight.
4. Tighten nut (5) and screw (8).

**12-86. VERTICAL LEVELING WORM DRIVECHAIN REPLACEMENT (Contd)**

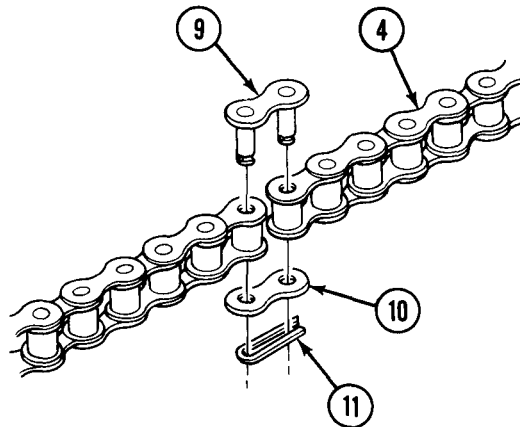
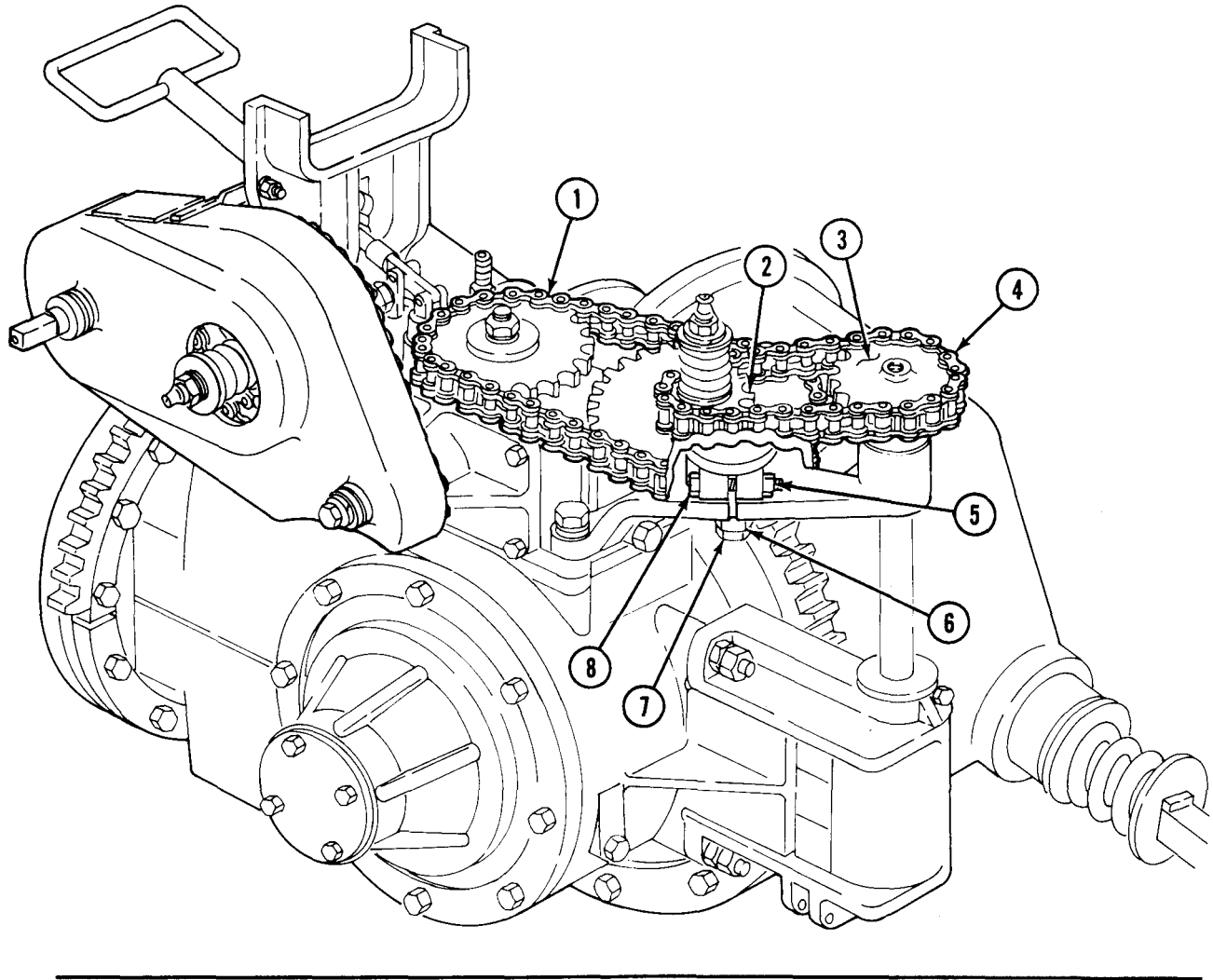

FOLLOW-ON TASK: Adjust vertical drivechain and install cover (para. 12-87).

## 12-87. LEVELING WORM COVER AND DRIVECHAIN MAINTENANCE

This task covers:

- |  |  |
|--|--|
| <ul style="list-style-type: none"> <li>a. Horizontal Drivechain Cover Removal</li> <li>b. Horizontal Drivechain Adjustment</li> <li>c. Horizontal Drivechain Cover Installation</li> </ul> | <ul style="list-style-type: none"> <li>d. Vertical Drivechain Cover Removal</li> <li>e. Vertical Drivechain Adjustment</li> <li>f. Vertical Drivechain Cover Installation</li> </ul> |
|--|--|

### INITIAL SETUP:

#### APPLICABLE MODELS

M764

#### MATERIALS/PARTS

Four lockwashers  
Safety wire (Appendix C, Item 22)

#### REFERENCES (TM)

TM 9-2320-361-10  
TM 9-2320-361-20P

#### EQUIPMENT CONDITION

Parking brake set (TM 9-2320-361-10).

### a. Horizontal Drivechain Cover Removal

1. Remove safety wire (11) from retaining collar (10), loosen setscrew (9), and remove retaining collar (10) from shaft (14). Discard safety wire (11).
2. Remove nut (3), lockwasher (2), and screw (13) from cover (12) and shifting handle bracket (1). Discard lockwasher (2).
3. Remove screw (8), lockwasher (7), washer (6), bushing (5), and cover (12) from gear (4). Discard lockwasher (7).

### b. Horizontal Drivechain Adjustment

1. Check freeplay by pushing up at midpoint of drivechain. Acceptable freeplay is 0.5 in. (1.27 cm).

#### NOTE

If freeplay is acceptable, proceed to subtask c. If freeplay is unacceptable, perform steps 2 through 4.

2. To adjust freeplay, loosen nut (16) and screw (15).
3. Hold shaft (17) and turn eccentric bushing (18) until freeplay is 0.5 in. (1.27 cm).
4. Tighten nut (16) and screw (15).

### c. Horizontal Drivechain Cover Installation

1. Install cover (12) on gear (4) with bushing (5), washer (6), new lockwasher (7), and screw (8).
2. Install screw (13) through cover (12) and shifting handle bracket (1) with new lockwasher (2) and nut (3).
3. Install retaining collar (10) on shaft (14) aligned with slot and tighten setscrew (9).
4. Wrap new safety wire (11) around retaining collar (10) and setscrew (9).

**12-87. LEVELING WORM COVER AND DRIVECHAIN MAINTENANCE (Contd)**

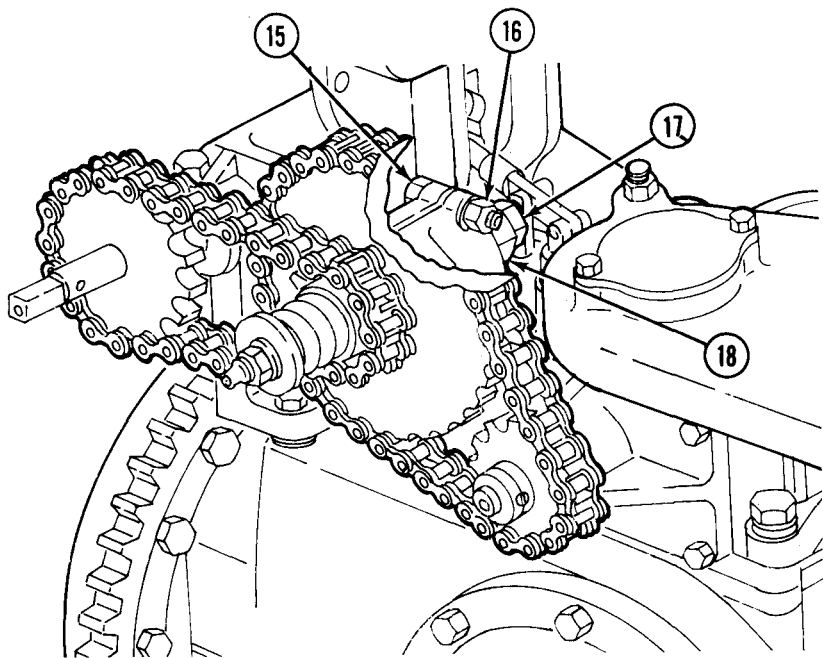
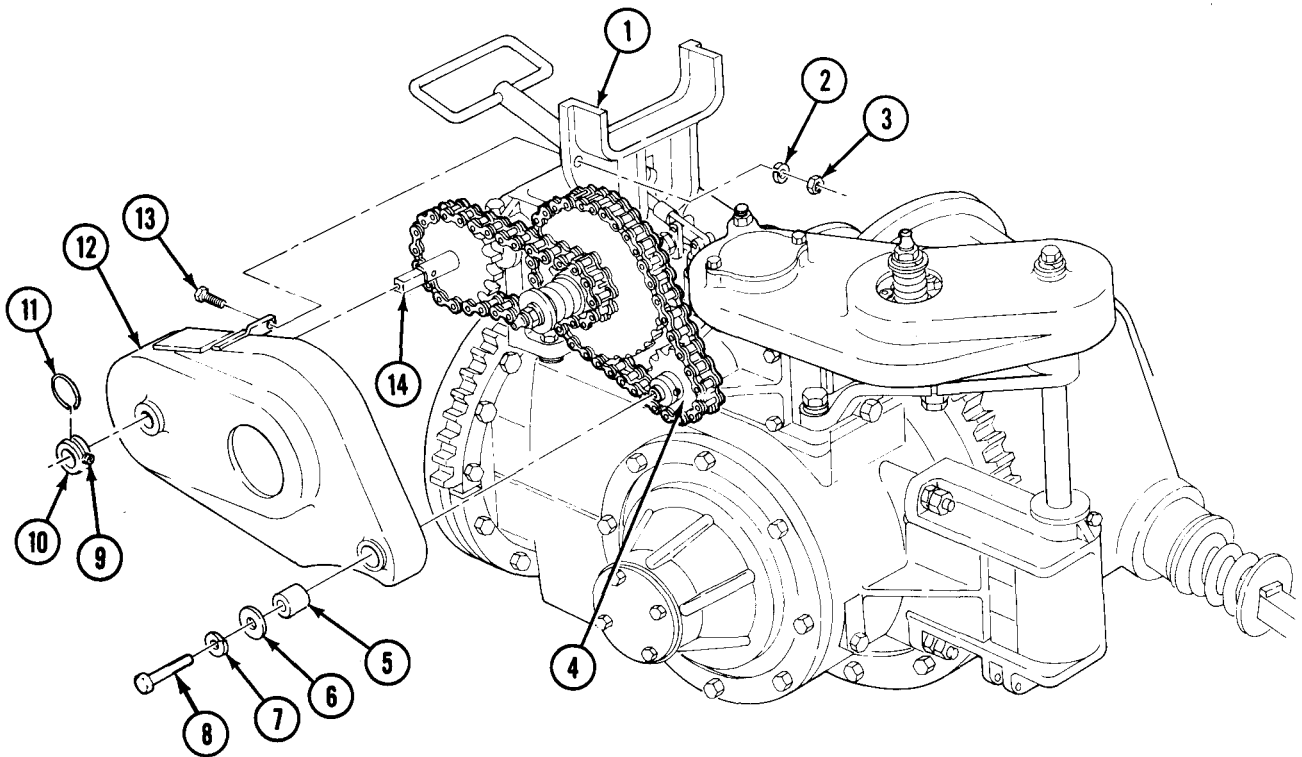

## 12-87. LEVELING WORM COVER AND DRIVECHAIN MAINTENANCE (Contd)

### d. Vertical Drivechain Cover Removal

1. Remove nut (1) and lockwasher (13) from stud (11). Discard lockwasher (13).
2. Remove screw (2), lockwasher (3), washer (4), bushing (5), and cover (12) from gear (6). Discard lockwasher (3).

### e. Vertical Drivechain Adjustment

1. Check freeplay by pushing up at midpoint of drivechain. Acceptable freeplay is 0.5 in. (1.27 cm).

#### NOTE

If freeplay is acceptable, proceed to subtask f. If freeplay is unacceptable, perform steps 2 through 4.

2. To adjust freeplay, loosen nut (7) and screw (10).
3. Hold shaft (9) and turn eccentric bushing (8) until freeplay is 0.5 in. (1.27 cm).
4. Tighten nut (7) and screw (10).

### f. Vertical Drivechain Cover Installation

1. Install cover (12) on gear (6) with bushing (5), washer (4), new lockwasher (3), and screw (2).
2. Install new lockwasher (13) and nut (1) on stud (11).

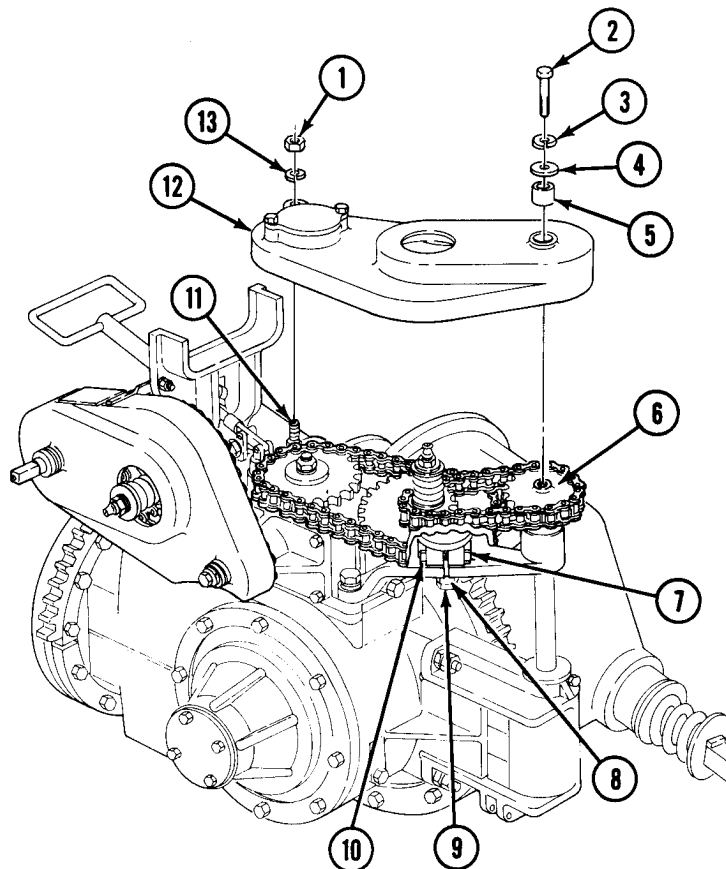

## 12-88. HYDRAULIC OIL LEVEL GAGE AND SCREEN REPLACEMENT

This task covers:

a. Removal

b. Installation

INITIAL SETUP:

### APPLICABLE MODELS

M764

### EQUIPMENT CONDITION

Parking brake set (TM 9-2320-361-10).

### REFERENCES (TM)

TM 9-2320-361-10

TM 9-2320-361-20P

### a. Removal

Remove air breather valve (1), gage (2), washer (3), and oil filter screen (4) from tank (5).

### b. Installation

Install oil filter screen (4), washer (3), gage (2), and air breather valve (1) on tank (5).

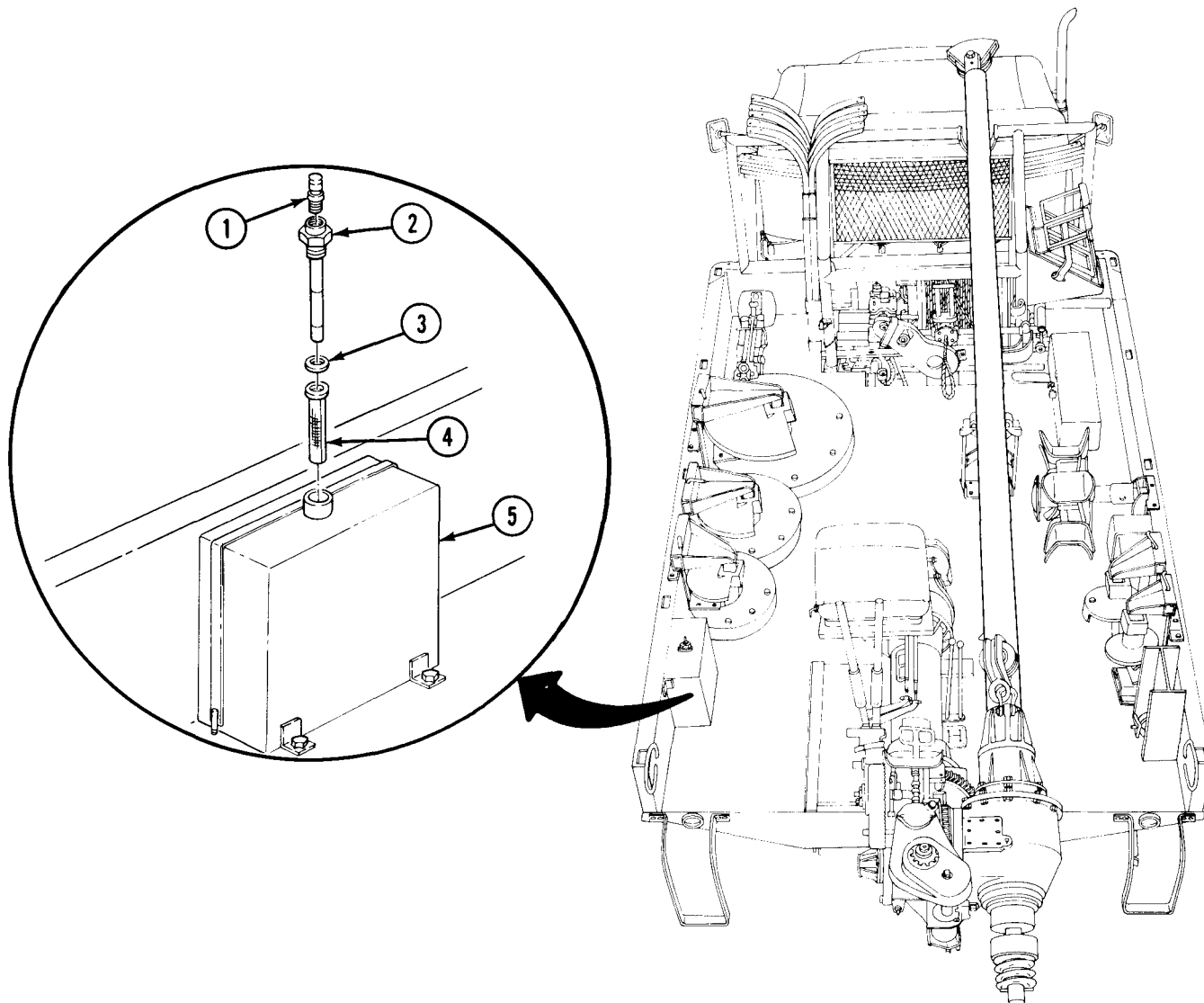

## 12-89. EARTH BORING MACHINE PROPELLER SHAFT MAINTENANCE

This task covers:

- a. Removal
- b. Disassembly
- c. Assembly
- d. Installation

### INITIAL SETUP:

#### APPLICABLE MODELS

M764

#### MATERIALS/PARTS

Eight locknuts  
GM grease (Appendix C, Item 13)

#### REFERENCES (TM)

TM 9-2320-361-10

TM 9-2320-361-20P

#### EQUIPMENT CONDITION

Parking brake set (TM 9-2320-361-10).

### a. Removal

1. Remove four locknuts (14), screws (15), and yoke flange (3) from power divider flange (1). Discard locknuts (14).
2. Remove four locknuts (10), screws (12), and shaft flange (9) from clutch drive flange (11). Discard locknuts (10).
  
1. Inspect two universal joints (13) for looseness or roughness. Replace universal joint(s) (13) if damaged (para. 7-4).
2. Loosen cap (7) and remove shaft (8), cap (7), washer (6), seal (5), and yoke (4).
3. Remove three lubrication fittings (2).

### c. Assembly

1. Apply GAA grease to splines of shaft (8).
2. Install seal (5), washer (6), and cap (7).
3. Slide shaft (8) into yoke (4) and tighten cap (7).
4. Install three lubrication fittings (2).

### d. Installation

1. Install shaft flange (9) on clutch drive flange (11) with four screws (12) and new locknuts (10). Do not tighten locknuts (10).
2. Install yoke flange (3) on power divider flange (1) with four screws (15) and new locknuts (14). Tighten four locknuts (10) and (14) 90-120 lb-ft (122-163 N-m).

**12-89. EARTH BORING MACHINE PROPELLER SHAFT MAINTENANCE (Contd)**

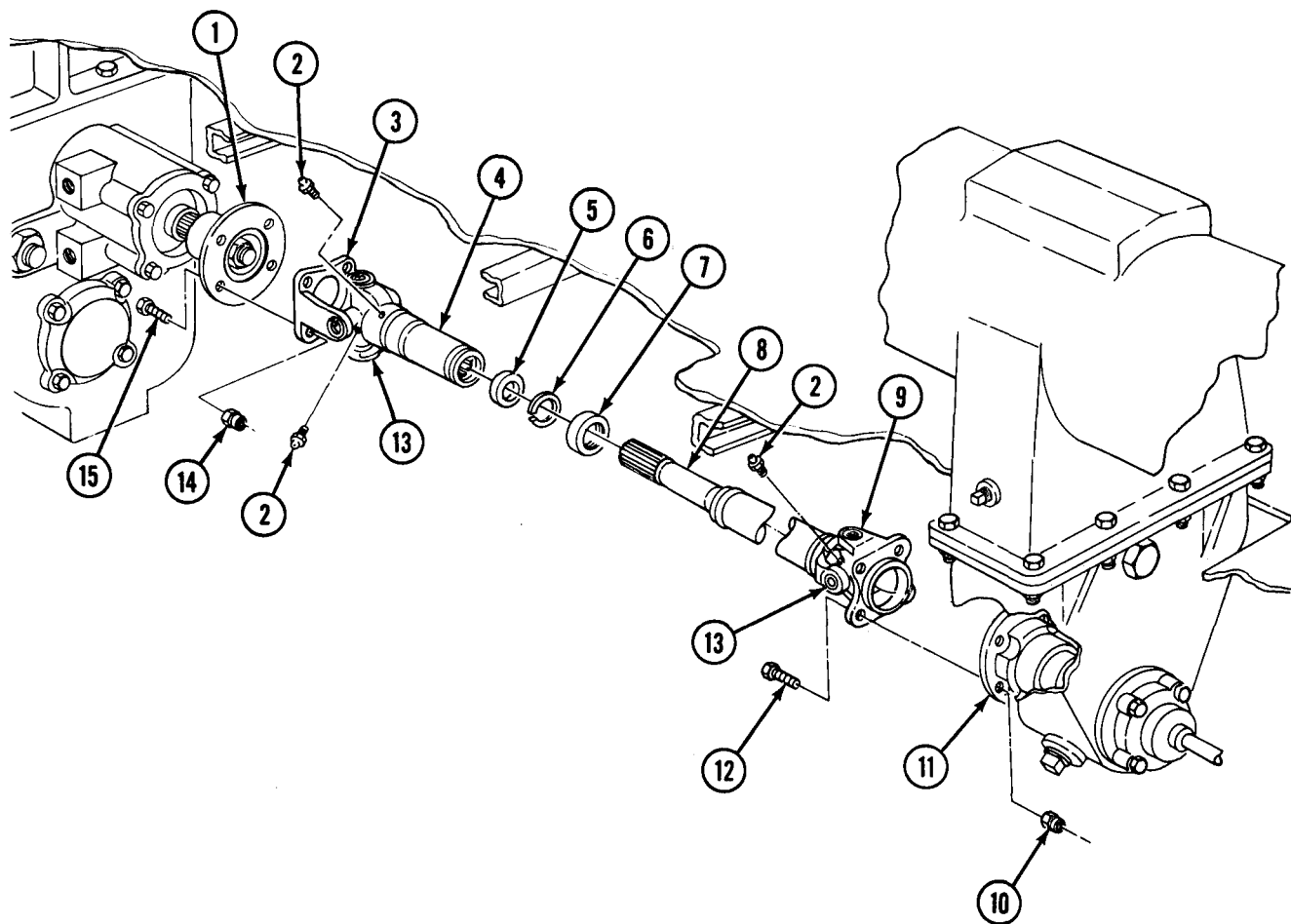



## 12-90. HYDRAULIC PUMP UNIVERSAL JOINT MAINTENANCE

This task covers:

- a. Removal
- b. Disassembly
- c. Cleaning and Inspection
- d. Assembly
- e. Installation

### INITIAL SETUP:

#### APPLICABLE MODELS

M764

#### MATERIALS/PARTS

Four locknuts  
Two woodruff keys  
GM grease (Appendix C, Item 13)  
Drycleaning solvent (Appendix C, Item 26)

#### PERSONNEL REQUIRED

Two

#### REFERENCES (TM)

TM 9-2320-361-10  
TM 9-2320-361-20P

#### EQUIPMENT CONDITION

Parking brake set (TM 9-2320-361-10).

#### GENERAL SAFETY INSTRUCTIONS

Keep fire extinguisher nearby when using drycleaning solvent.

### NOTE

Forward and rear universal joints are removed the same way. This procedure covers the rear universal joint.

#### **a. Removal**

1. Loosen two setscrews (7) on universal joint (9).

### NOTE

Assistant will help with steps 2 through 4.

2. Remove four locknuts (2) and screws (4) from bracket (1) and pump (3).
3. Lower pump (3) and remove pump shaft (5) from universal joint (9).
4. Install pump (3) with two screws (4) and locknuts (2). Do not tighten locknuts (2). Discard remaining locknuts (2).
5. Remove universal joint (9) and two woodruff keys (6) from driveshaft (8). Discard woodruff keys (6).

#### **b. Disassembly**

Remove two clips (10) and boot (11) from universal joint (9).

#### **c. Cleaning and Inspection**

### WARNING

Drycleaning solvent is flammable and will not be used near open flame. Use only in well-ventilated places. Failure to do so may result in injury or death to personnel.

1. Clean all parts in drycleaning solvent and air dry.
2. Inspect parts for breaks, bends, cracks, burrs, scoring, and proper fit. Replace damaged parts.
3. Pack boot (11) with GM grease and apply a light coat to both ends of universal joint (9).

#### **d. Assembly**

Install boot (11) and two clips (10) on universal joint (9).

## 12-90. HYDRAULIC PUMP UNIVERSAL JOINT MAINTENANCE (Contd)

### e. Installation

1. Install two new woodruff keys (6) and universal joint (9) on driveshaft (8).

NOTE

Assistant will help with steps 2 and 3.

2. Remove two locknuts (2) and screws (4) from pump (3). Discard locknuts (2).
3. Install pump haft (5) in universal joint (9) and install pump (3) on bracket (1) with four screws (4) and new locknuts (2).
4. Tighten two setscrews (7).

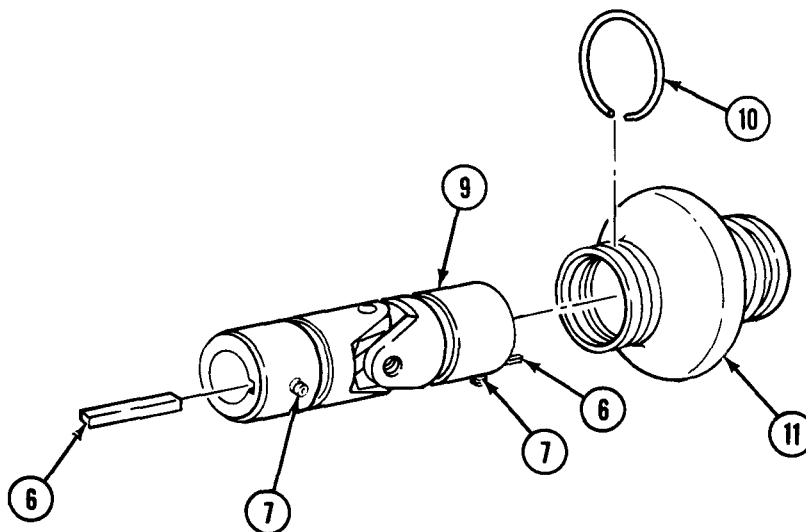
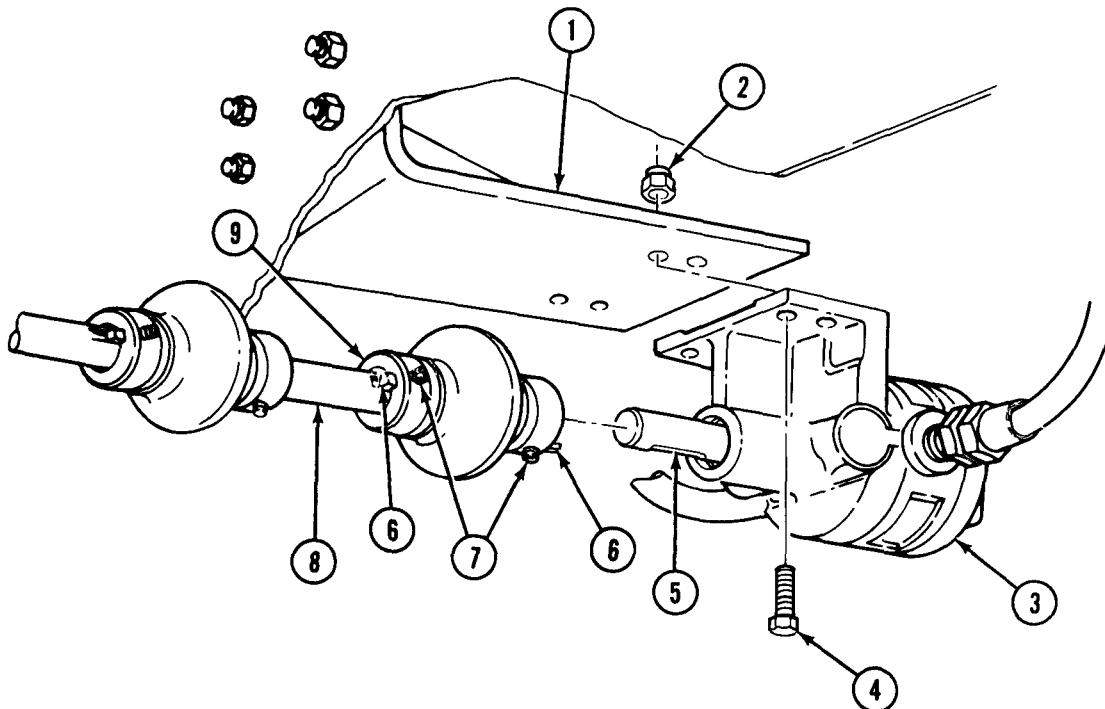

**12-91. OUTRIGGER HYDRAULIC LINES REPLACEMENT**

This task covers:

a. Removal

b. Installation

**INITIAL SETUP:**

**APPLICABLE MODELS**

M764

**REFERENCES (TM)**

TM 9-2320-361-10

TM 9-2320-361-20P

LO 9-2320-209-12-1

**MATERIALS/PARTS**

Three locknuts

Five tiedowns traps (Appendix C, Item 20)

Sealing compound (Appendix C, Item 25)

Cap and plug set (Appendix C, Item 8)

**EQUIPMENT CONDITION**

• Parking brake set (TM 9-2320-361-10).

• Hydraulic tank drained (LO 9-2320-209-12-1).

**CAUTION**

When disconnecting hydraulic lines and hoses, plug all openings to prevent dirt from entering and causing internal parts damage. Remove plugs prior to installation.

**a. Removal**

**NOTE**

- Tag all hoses for proper installation.
- Have drainage container ready to catch oil.

1. Remove two tiedown straps (2) from crossmember (3). Discard tiedown straps (2).
2. Remove screw (1), locknut (4), and two clamps (5) from hoses (6) and crossmember (3). Discard locknut (4).

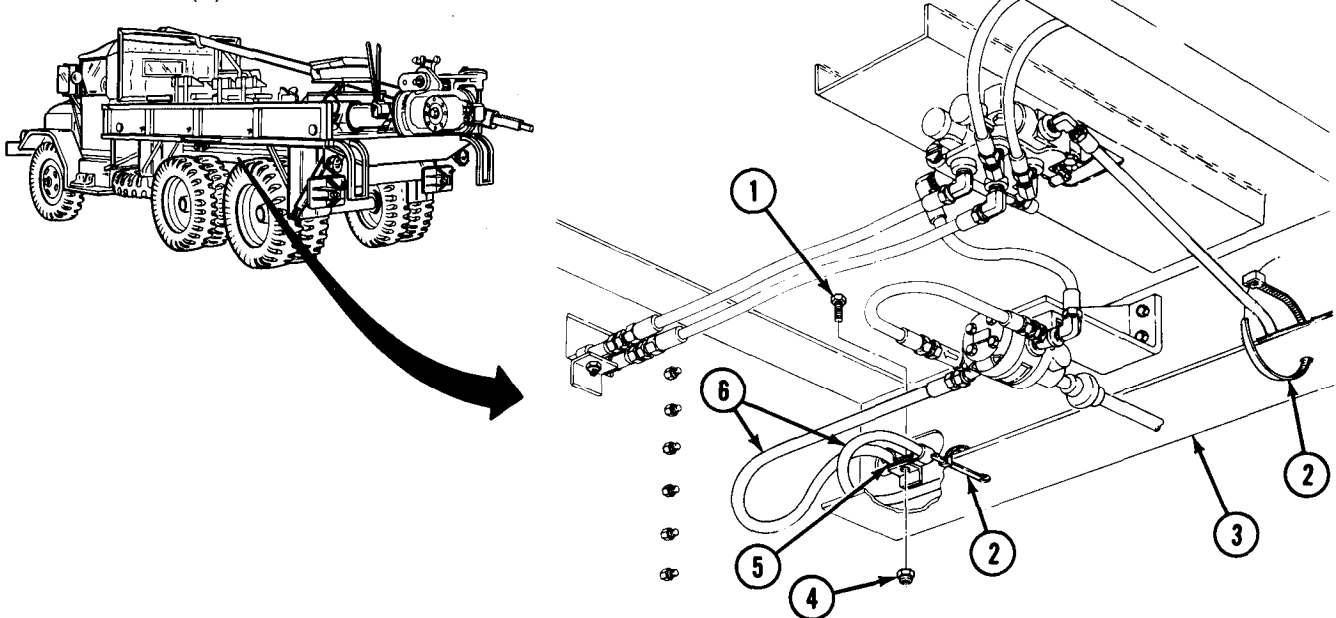

3. Remove two screws (7), locknuts (10), and deflector (8) from crossmember (9). Discard locknuts (10).
4. Disconnect hose (15) from adapter (11).
5. Remove three tiedown straps (14) and hose (15) from crossmember (9). Discard tiedown straps (14).
6. Remove adapter (11) from elbow (12).

**12-91. OUTRIGGER HYDRAULIC LINES REPLACEMENT (Contd)**

7. Remove elbow (12) from nipple (13).
8. Disconnect hose (6) from adapter (17).
9. Remove adapter (17) from tee (16).

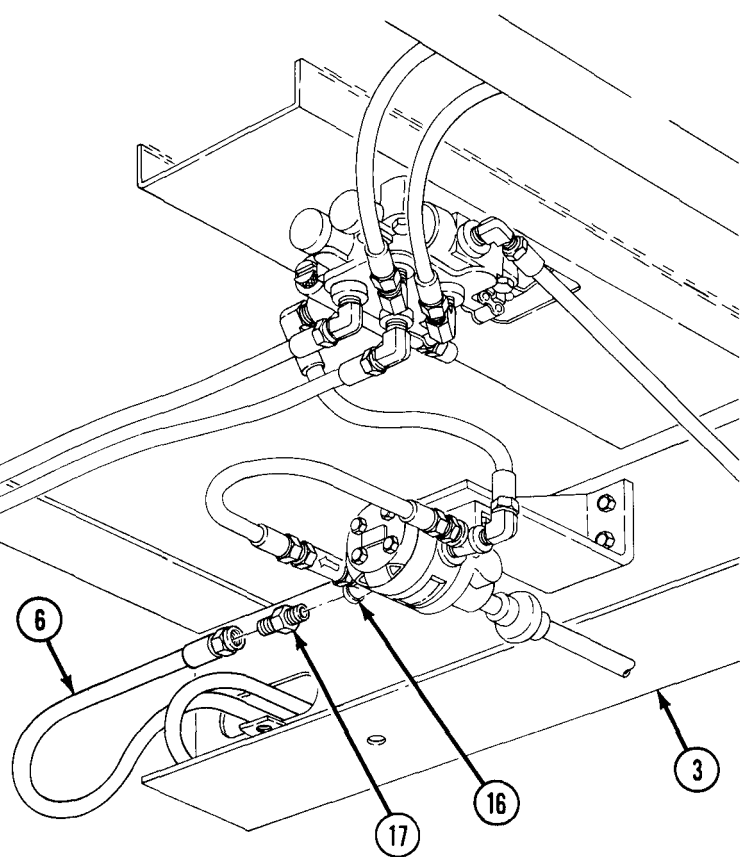
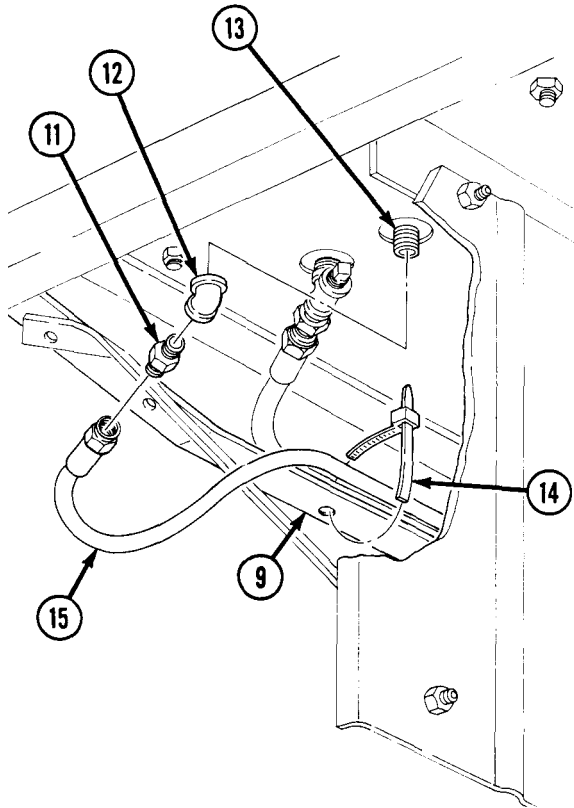
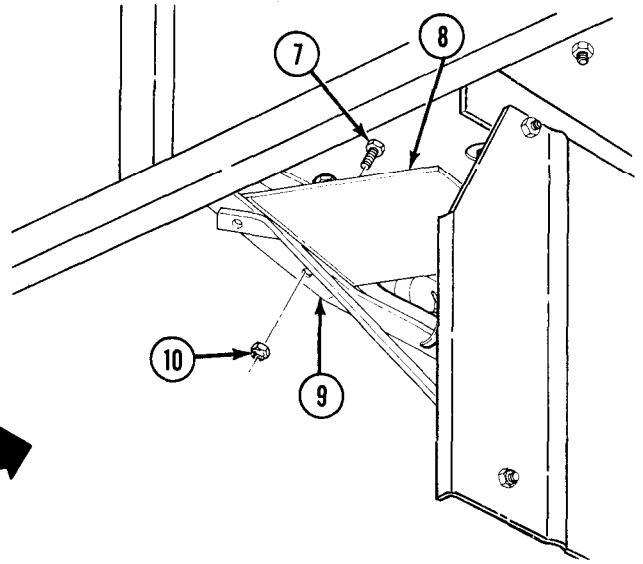
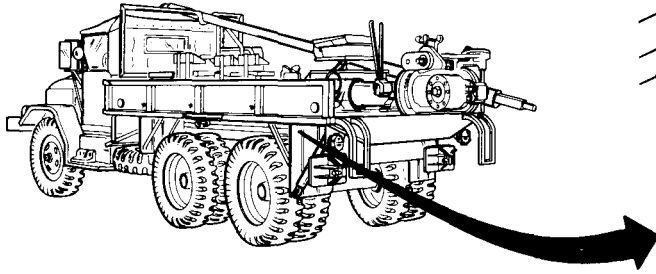

**12-91. OUTRIGGER HYDRAULIC LINES REPLACEMENT (Contd)**

9. Disconnect hose (5) from adapter (6) and elbow (8) and remove hose (5) from crossmember (4).
10. Remove plug (3), adapter (6), and tee (1) from nipple (2).
11. Remove elbow (8) from valve (7).
12. Disconnect hose (16) from check valve (15) and adapter (10).
13. Disconnect hose (9) from elbows (11) and (17).
14. Remove check valve (15), tee (14), adapter (10), elbow (11), and tee (12) from pump (13).
15. Remove elbow (17) from valve (7).

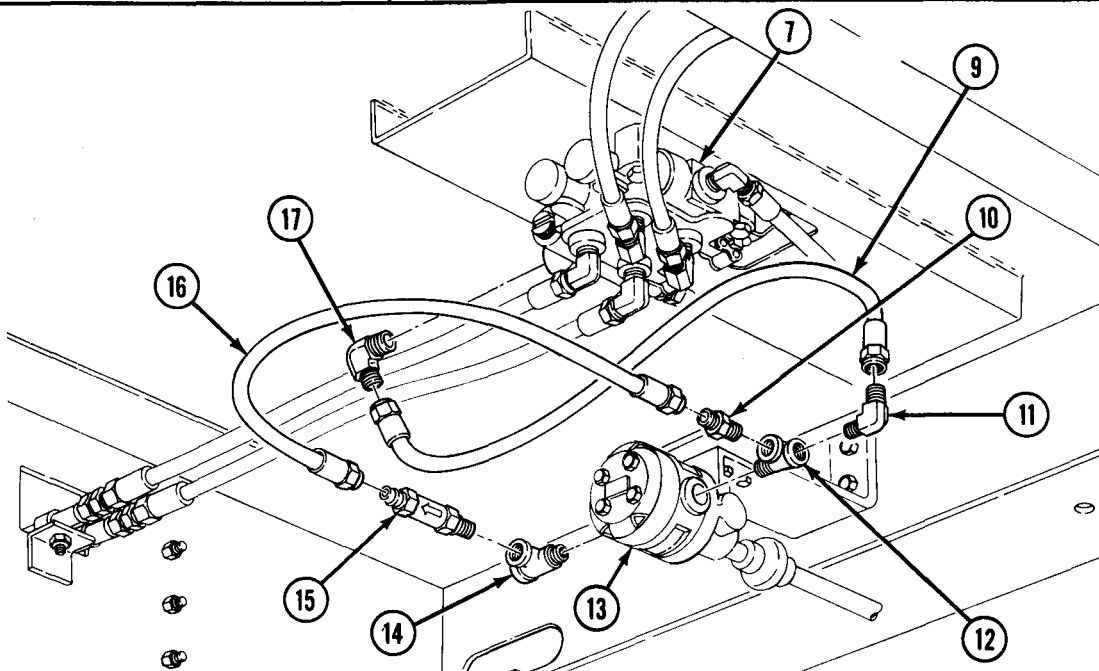
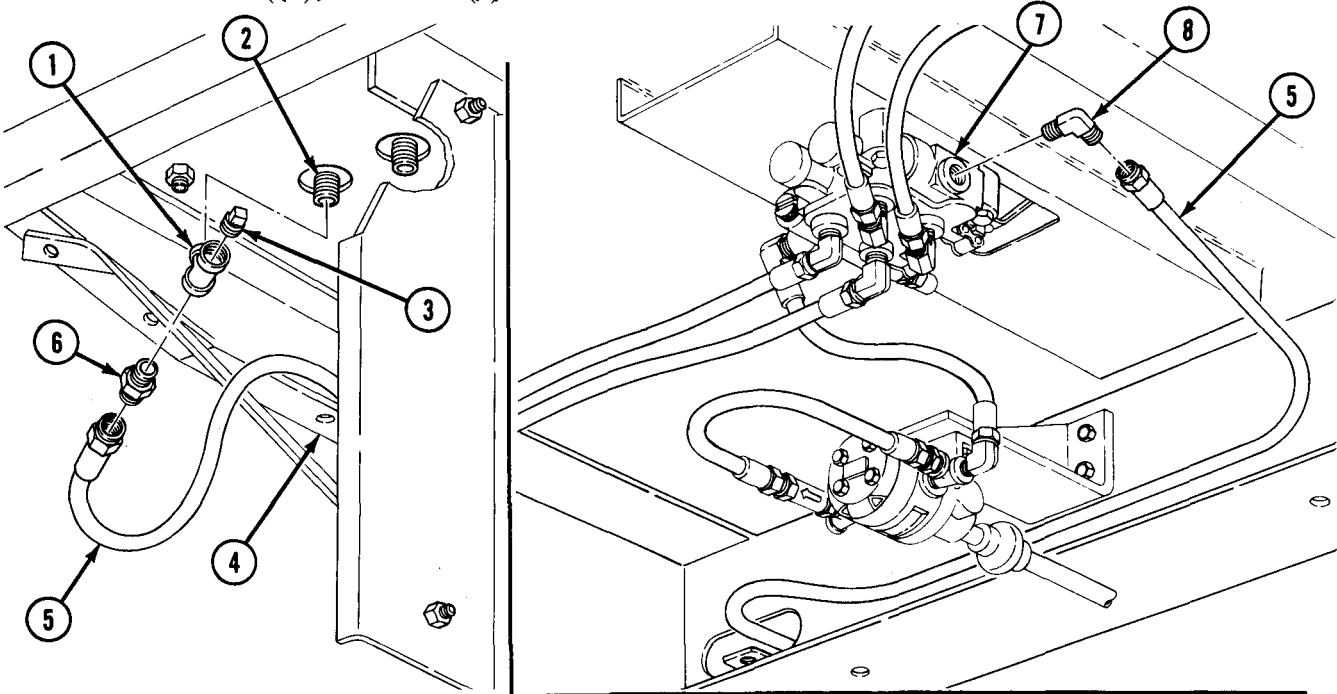

## 12-91. OUTRIGGER HYDRAULIC LINES REPLACEMENT (Contd)

16. Disconnect two hoses (29) from two elbows (24) and unions (25).
17. Remove two unions (25), sleeves (26), and nuts (27) from end of cylinders (28).
18. Remove two elbows (24) from valve (7).
19. Disconnect two hoses (18) from two elbows (19) and elbows (23).
20. Remove two elbows (19), sleeves (22), and nuts (21) from end of cylinders (20).
21. Remove two elbows (23) from valve (7).

### b. Installation

#### NOTE

Apply sealing compound to male pipe threads before installation.

1. Install two elbows (23) on valve (7).
2. Install two nuts (21), sleeves (22), and elbows (19) on end of cylinders (20).
3. Connect two hoses (18) to two elbows (23) and elbows (19).
4. Install two elbows (24) on valve (7).
5. Install two nuts (27), sleeves (26), and unions (25) on end of cylinders (28).
6. Connect two hoses (29) to two unions (25) and elbows (24).

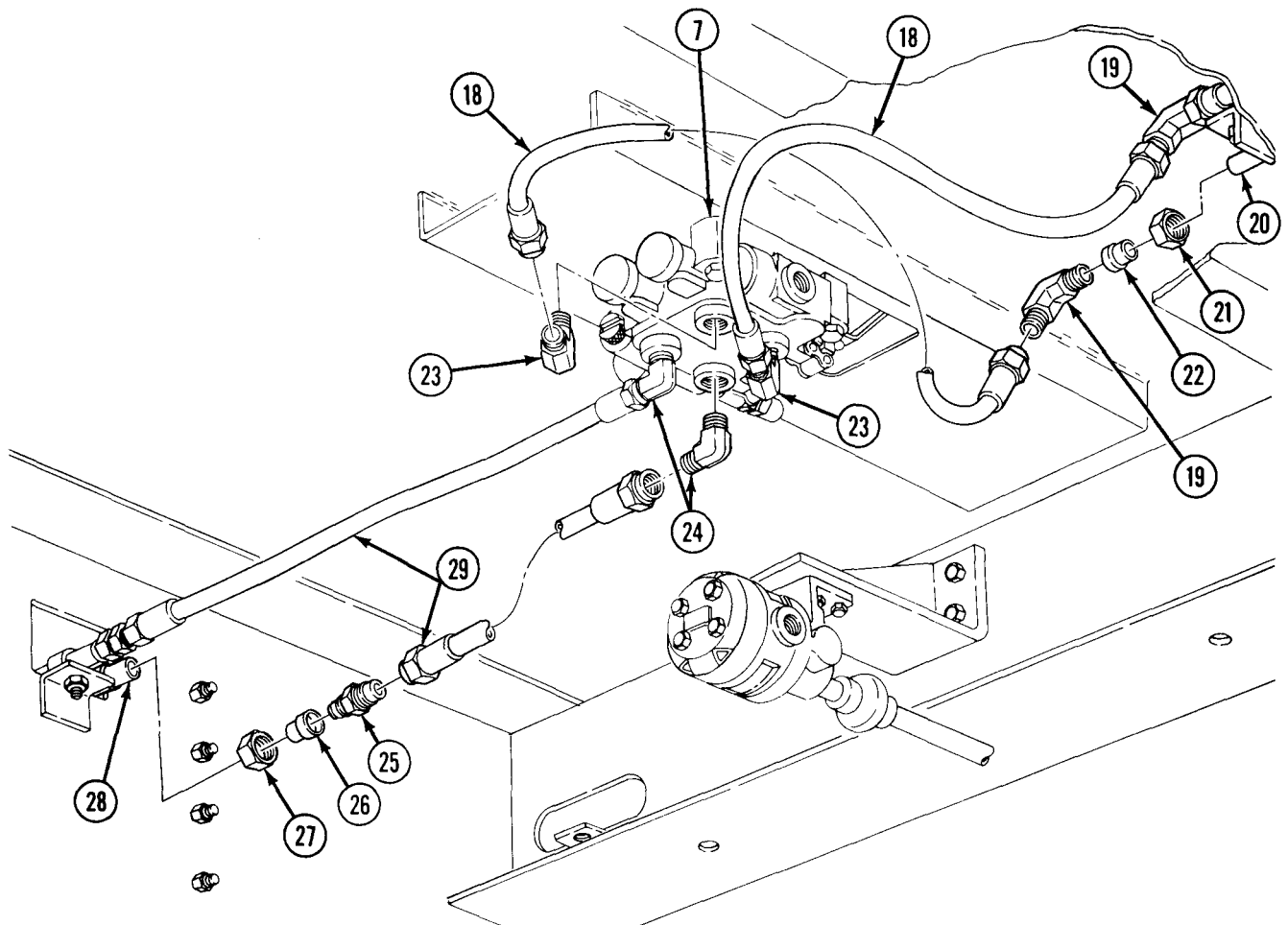

## 12-91. OUTRIGGER HYDRAULIC LINES REPLACEMENT (Contd)

7. Install elbow (2) on valve (3).
8. Install tees (7) and (9) on pump (8).
9. Install elbow (6) and adapter (5) on tee (7) and install check valve (10) on tee (9).
10. Connect hose (4) to elbows (6) and (2).
11. Connect hose (1) to adapter (5) and check valve (10).

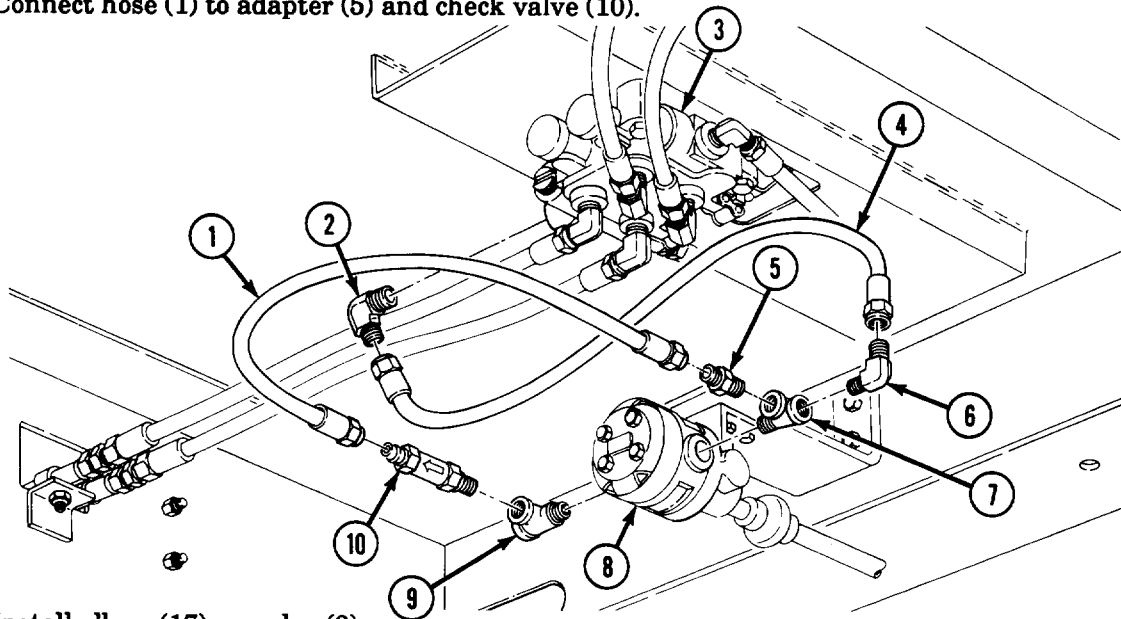

12. Install elbow (17) on valve (3).
13. Install tee (16), adapter (15), and plug (12) on nipple (11).
14. Position hose (14) on crossmembers (13) and (18) and connect to adapter (15) and elbow (17).

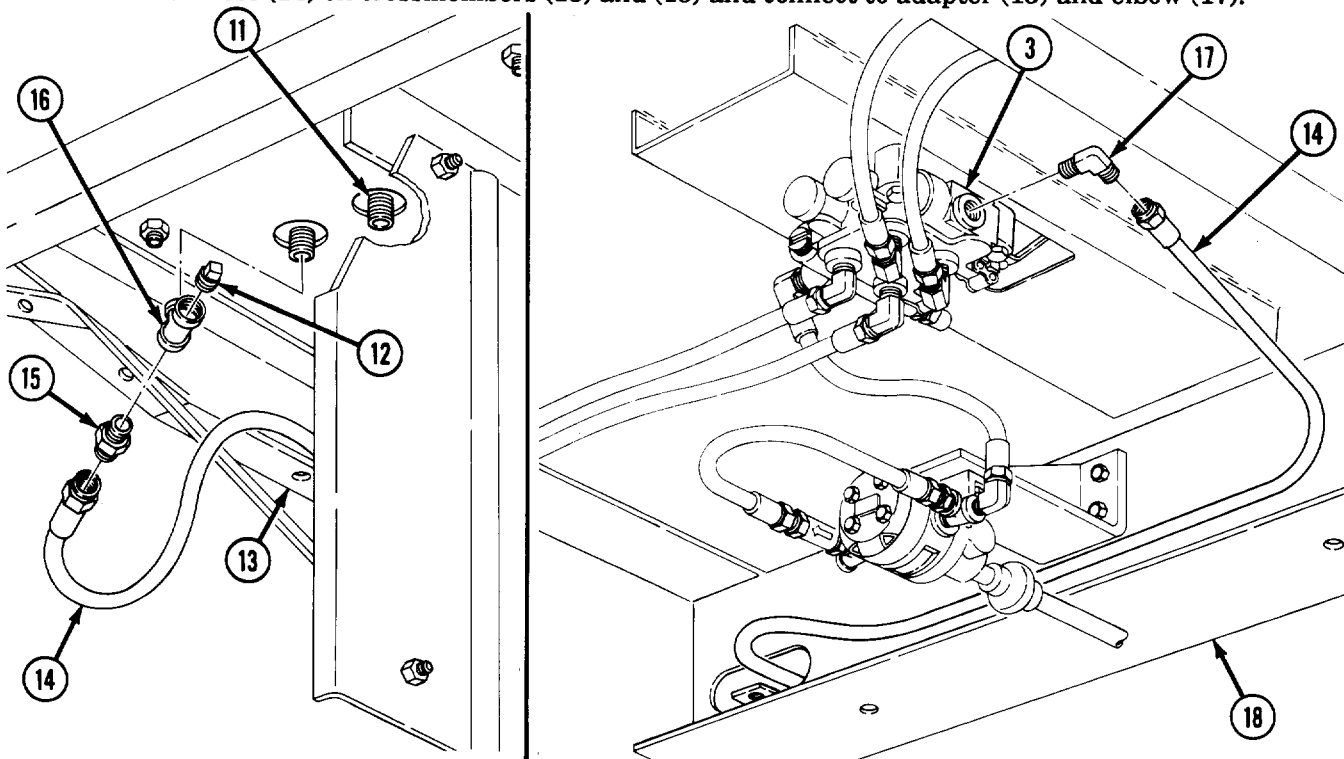

**12-91. OUTRIGGER HYDRAULIC LINES REPLACEMENT (Contd)**

15. Install adapter (24) on tee (9).
16. Install elbow (20) and adapter (19) on nipple (21).
17. Install hose (23) on crossmember (13) with three new tiedown straps (22) and connect hose (23) to adapters (19) and (24).
18. Install deflector (25) on crossmember (13) with two screws (26) and new locknuts (27).
19. Install two clamps (30) on hoses (23) and (14) and crossmember (18) with screw (28) and new locknut (31).
20. Install two new tiedown straps (29) on hose (14) and crossmember (18).

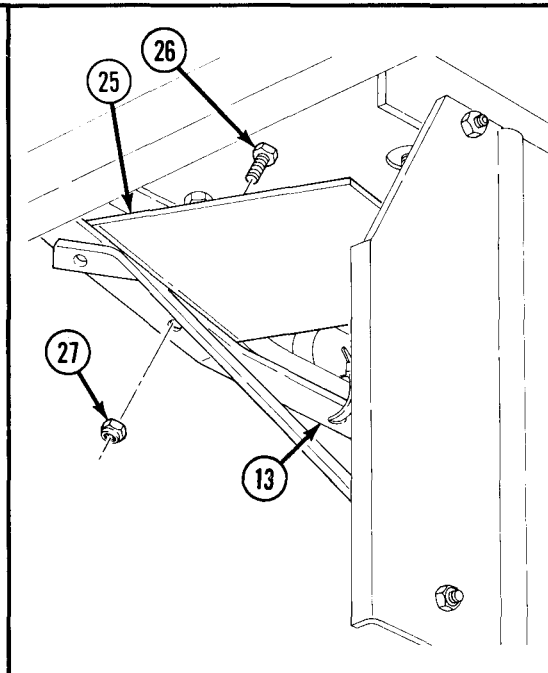
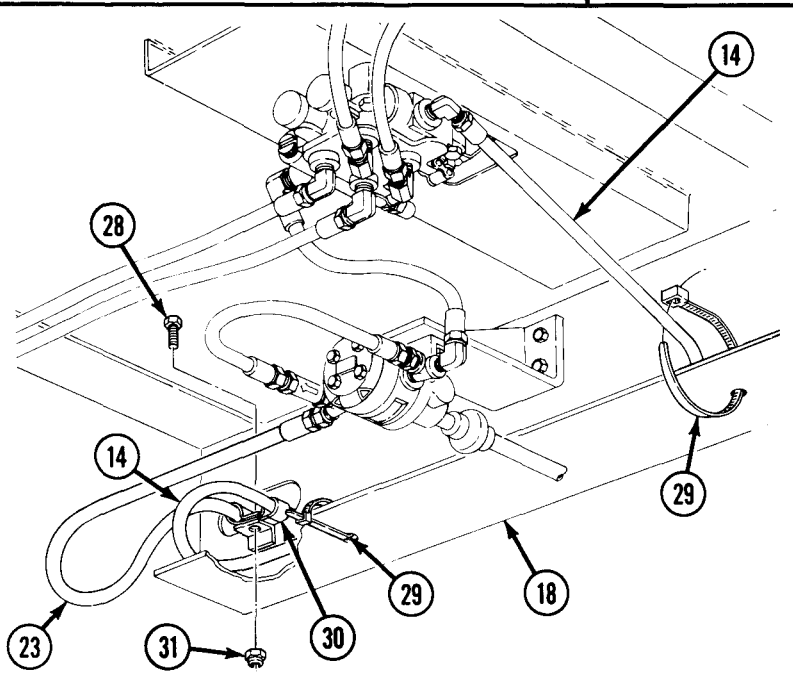
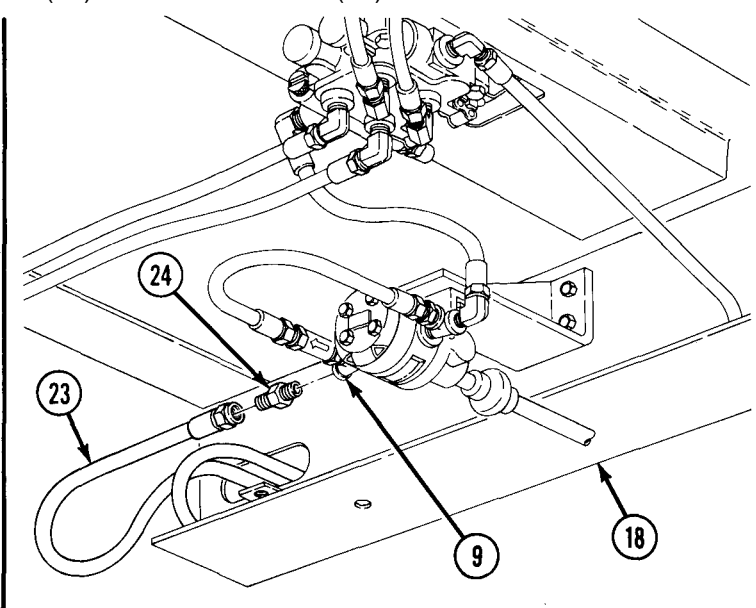
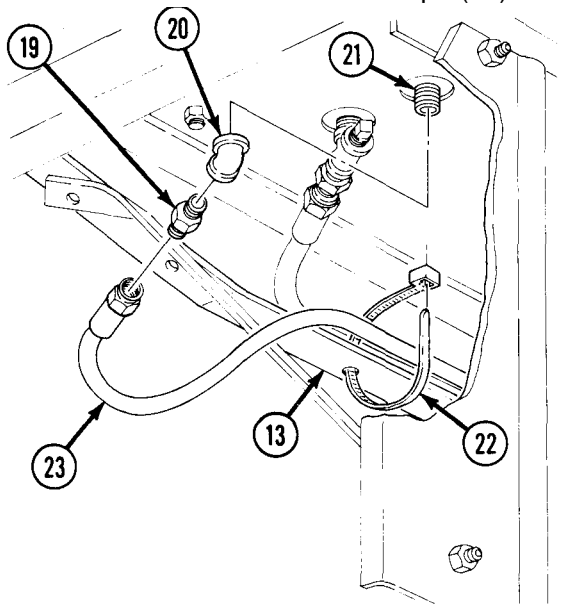

FOLLOW-ON TASK: Fill hydraulic tank (LO 9-2320-209-12-1).



## 12-92. EARTH BORING MACHINE SEAT FRAME REPLACEMENT

This task covers:

**a. Removal**

**b. Installation**

**INITIAL SETUP:**

APPLICABLE MODELS

M764

MATERIALS/PARTS

Cotter pin

Four locknuts

REFERENCES (TM)

TM 9-2320-361-10

TM 9-2320-361-20P

EQUIPMENT CONDITION

- Parking brake set (TM 9-2320-361-10).
- Earth boring machine seat and seat backrest cushion removed (para. 12-93).

**a. Removal**

1. Remove cotter pin (11), washer (12), spring (10), pin (2), and seat adjustment handle (3) from seat frame (1). Discard cotter pin (11).
2. Remove four locknuts (4) and washers (5) from seat frame (1). Discard locknuts (4).
3. Remove seat frame (1) and four washers (13) from seat base (6).
4. Remove safety pin (7), pin (9), and seat base (6) from boring machine (8).

**b. Installation**

1. Install seat base (6) on boring machine (8) with pin (9) and safety pin (7).

**NOTE**

Seat frame must slide freely after installation.

2. Install four washers (13) and seat frame (1) on seat base (6) with four washers (5) and new locknuts (4).
3. Install seat adjustment handle (3) on seat frame (1) with pin (2), spring (10), washer (12), and new cotter pin (11).

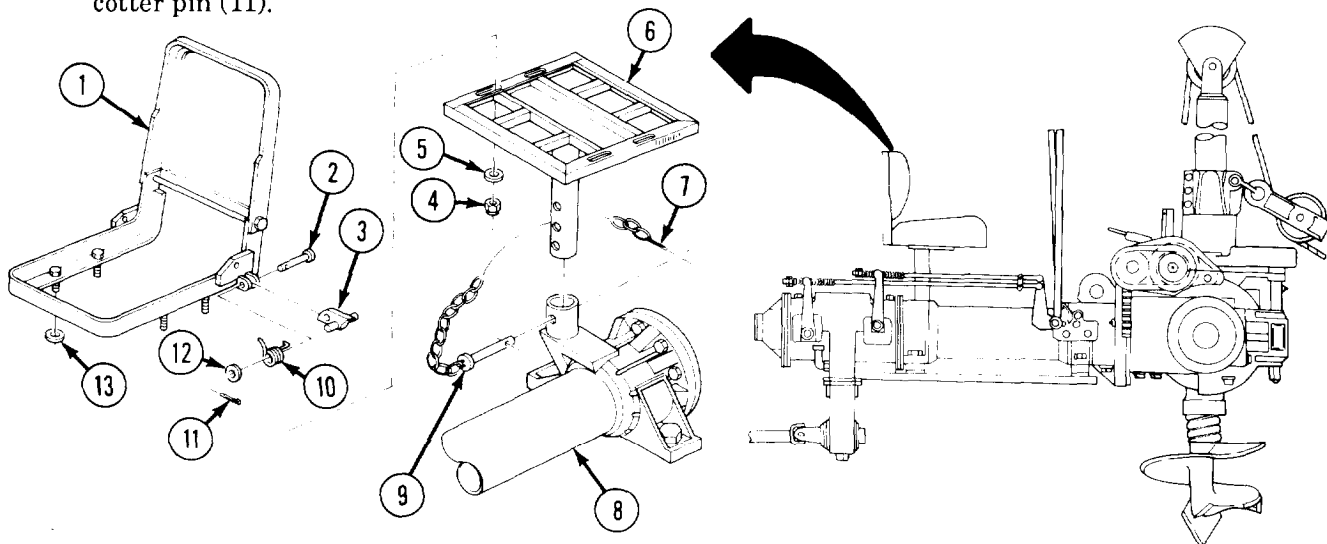

**FOLLOW-ON TASK:** Install earth boring machine seat and seat backrest cushion (para. 12-93).

## 12-93. EARTH BORING MACHINE SEAT AND SEAT BACKREST CUSHION REPLACEMENT

This task covers:

a. Removal

b. Installation

### INITIAL SETUP:

#### APPLICABLE MODELS

M764

#### MATERIALS/PARTS

Two locknuts

#### REFERENCES (TM)

TM 9-2320-361-10

TM 9-2320-361-20P

#### EQUIPMENT CONDITION

Parking brake set (TM 9-2320-361-10).

### a. Removal

1. Remove seat backrest cushion (1) from backrest frame (2).
2. Remove two locknuts (3) and screws (5) from seat cushion (6) and seat frame (4). Discard locknuts (3).
3. Remove seat cushion (6) from seat frame (4).

### b. Installation

1. Install seat cushion (6) on seat frame (4) with two screws (5) and new locknuts (3).
2. Install seat backrest cushion (1) on backrest frame (2).

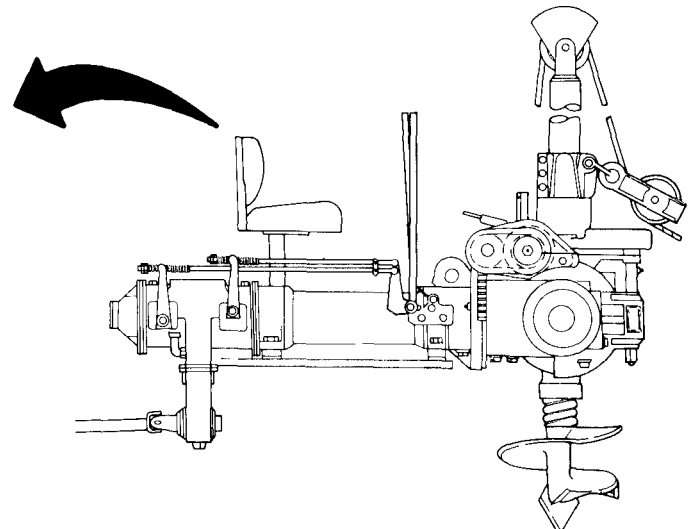
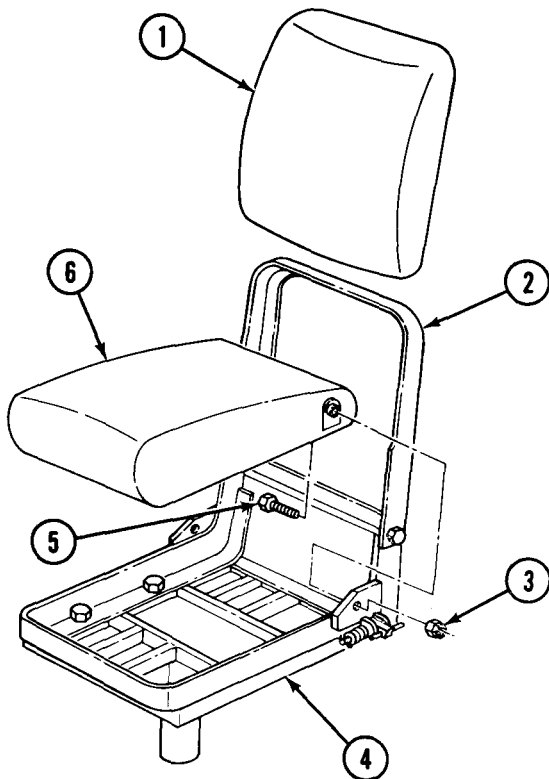

## 12-94. COLLAPSIBLE CABLE REEL DISASSEMBLY

This task covers:

a. Disassembly

b. Assembly

### INITIAL SETUP:

APPLICABLE MODELS

M764

MATERIALS/PARTS

Twenty-one cotter pins

REFERENCES (TM)

TM 9-2320-361-10

TM 9-2320-361-20P

EQUIPMENT CONDITION

ZParking brake set (TM 9-2320-361-10).

•Collapsible cable reel removed (TM 9-2320-361-10).

### a. Disassembly

1. Remove plug (6) with handle (4) and two shims (20) from spindle (16) and sliding spider (19).
2. Remove cotter pin (8), nut (7), screw (1 washer (2), spacer (3), plug (6), and spring (5) from handle (4). Discard cotter pin (8).
3. Remove six cotter pins (21) and pins (23) from sliding spider (19) and six connecting links (22). Discard cotter pins (21).
4. Remove cotter pin (13) and pin (18) from sliding spider (19) and remove spider (19) from spindle (16). Discard cotter pin (13).
5. Remove six cotter pins (24), pins (26), and connecting links (22) from six rim segments (25). Discard cotter pins (24).
6. Remove six cotter pins (12), pins (9), and rim segments (25) from spider (10). Discard cotter pins (12).
7. Remove cotter pin (14) and pin (11) from spider (10). Discard cotter pin (14).
8. Remove spider (10), rivet (17), and spring (15) from spindle (16).

### b. Assembly

1. Install spring (15) and rivet (17) in spindle (16).
2. Install spider (10) on spindle (16) with pin (11) and new cotter pin (14).
3. Install six rim segments (25) on spider (10) with six pins (9) and new cotter pins (12).
4. Install six connecting links (22) on rim segments (25) with six pins (26) and new cotter pins (24).
5. Install sliding spider (19) on spindle (16) with pin (18) and new cotter pin (13).
6. Install six connecting links (22) on sliding spider (19) with six pins (23) and new cotter pins (21).
7. Install spring (5), plug (6), spacer (3), washer (2), screw (1), nut (7), and new cotter pin (8) in handle (4).
8. Install two shims (20) and handle (4) with plug (6) on spindle (16).

**12-94. COLLAPSIBLE CABLE REEL DISASSEMBLY (Contd)**

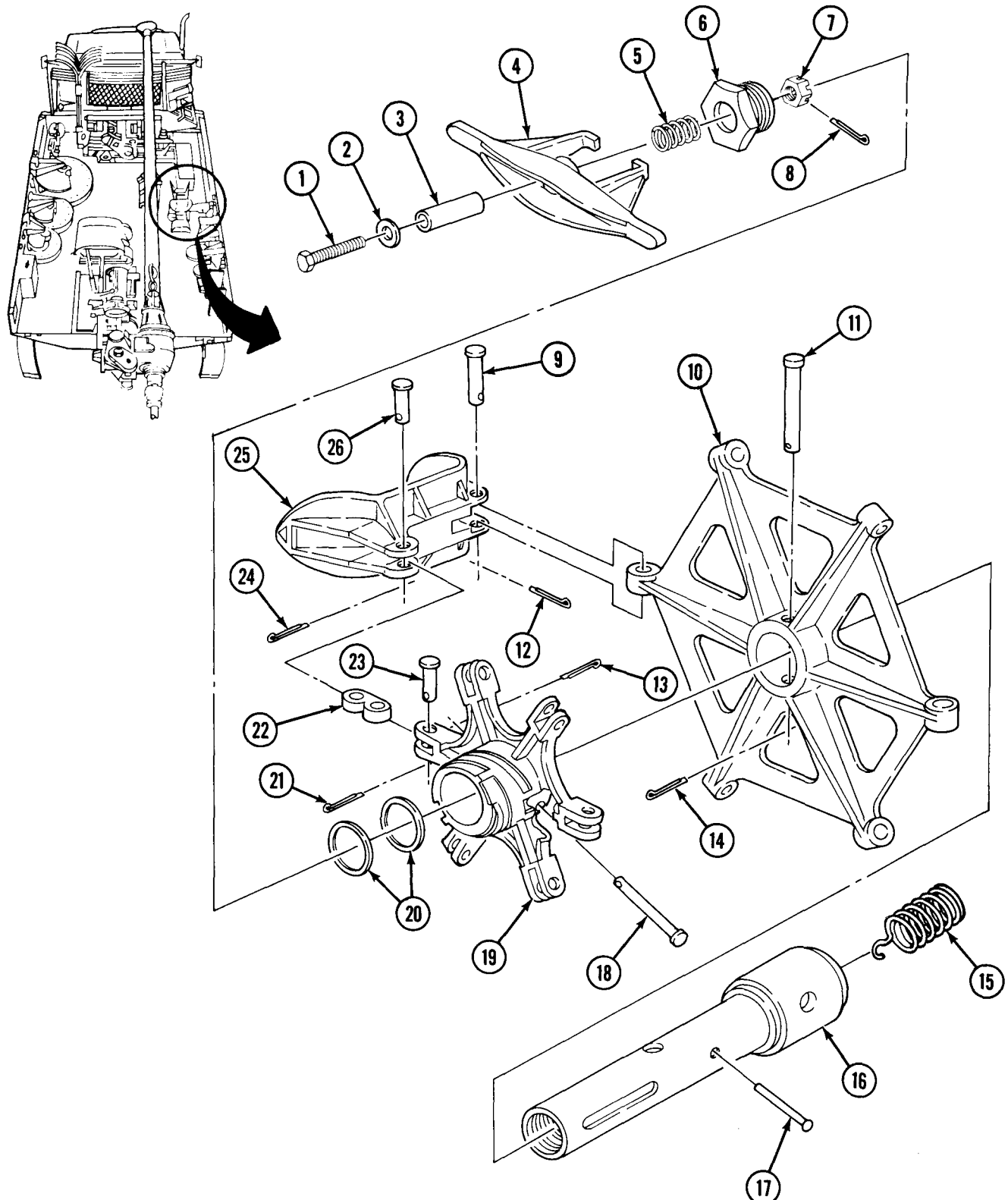

FOLLOW-ON TASK: Install collapsible cable reel (TM 9-2320-361-10).

## 12-95. HYDRAULIC TANK REPLACEMENT

This task covers:

**a. Removal**

**b. Installation**

**INITIAL SETUP:**

APPLICABLE MODELS

M764

MATERIALS/PARTS

Six locknuts

Sealing compound (Appendix C, Item 25)

Cap and plug set (Appendix C, Item 8)

PERSONNEL REQUIRED

Two

REFERENCES (TM)

LO 9-2320-209-12-1

TM 9-2320-361-10

TM 9-2320-361-20P

EQUIPMENT CONDITION

• Parking brake set (TM 9-2320-361-10).

Ž Hydraulic oil level gage and screen removed (para. 12-88).

CAUTION

When disconnecting hydraulic hoses, plug all openings to prevent dirt from entering and causing internal parts damage. Remove plugs prior to installation.

NOTE

Ž Tag hoses for proper installation.

Ž Have drainage container ready to catch oil.

1. Remove two locknuts (13), screws (1), and deflector (2) from crossmember (12). Discard locknuts (13).
2. Remove plug (5) and drain oil.
3. Remove hose (9), adapter (10), and tee (11) from nipple (3).
4. Remove hose (8), adapter (7), and elbow (6) from nipple (4).
5. Remove two locknuts (19), washers (20), and retainer (14) from body (21). Discard locknuts (19).

NOTE

Assistant will help with step 6.

6. Remove two locknuts (18), washers (17), screws (16), and hydraulic tank (15) from body (21). Discard locknuts (18).

**b. Installation**

NOTE

Ž Apply sealing compound to male pipe threads before installation.

• Assistant will help with step 1.

1. Install hydraulic tank (15) on body (21) with two screws (16), washers (17), and new locknuts (18).
2. Install retainer (14) on body(21) with two washers (20) and new locknuts (19).
3. Install elbow (6), adapter (7), and hose (8) on nipple (4).
4. Install tee (11), adapter (10), and hose (9) on nipple (3).
5. Install plug (5) on tee (11).
6. Install deflector (2) on crossmember (12) with two screws (1) and new locknuts (13).

**12-95. HYDRAULIC TANK REPLACEMENT (Contd)**

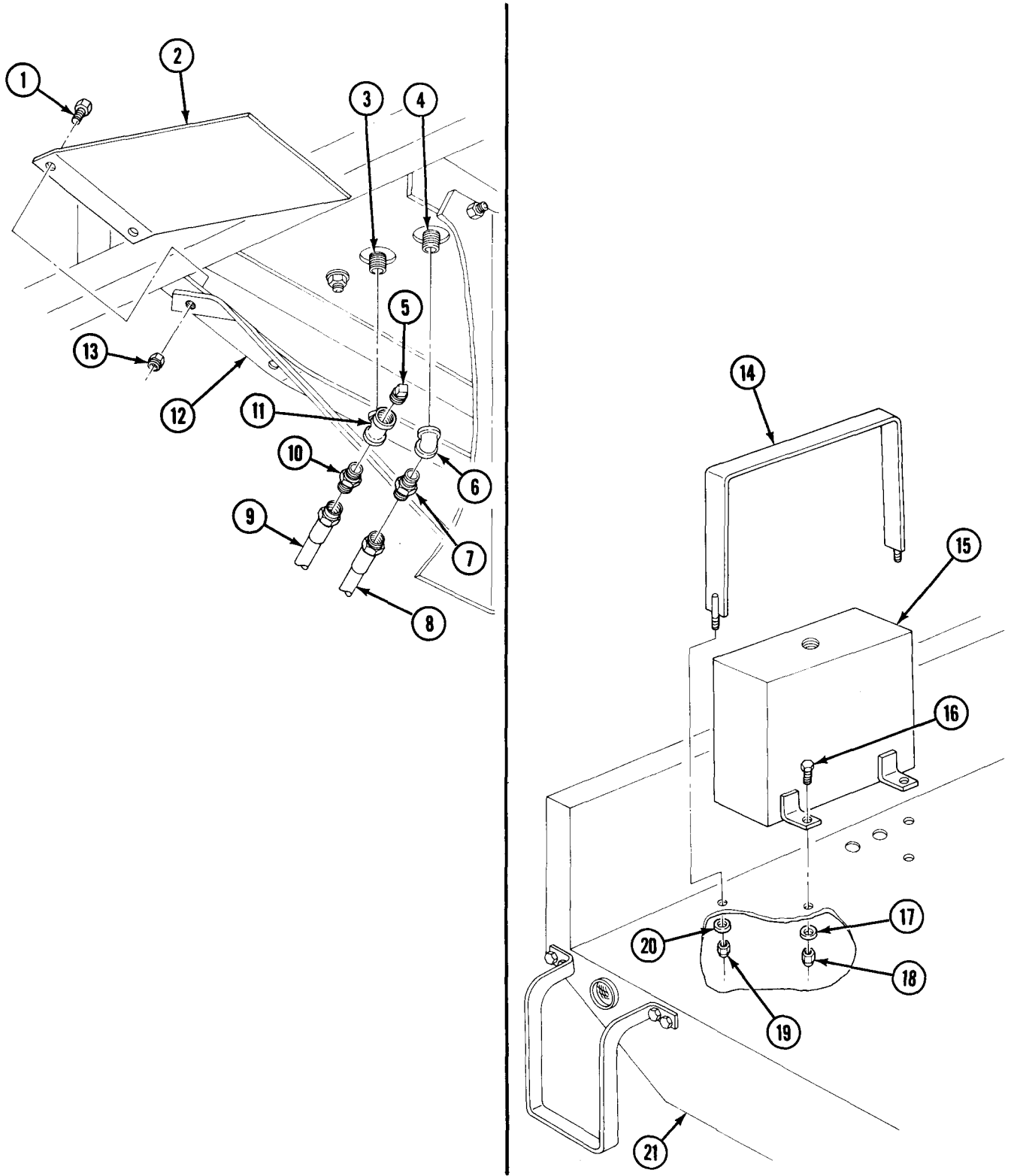

FOLLOW-ON TASKS: •Fill hydraulic tank with oil (LO 9-2320-209-12-1).  
 •Install oil level gage and screen (para. 12-88).

## 12-96. OPERATION LEVERS MAINTENANCE

This task covers:

- |  |  |
|--|--|
| <ul style="list-style-type: none"> <li>a. Removal</li> <li>b. Disassembly</li> </ul> | <ul style="list-style-type: none"> <li>c. Assembly</li> <li>d. Installation</li> </ul> |
|--|--|

### INITIAL SETUP:

#### APPLICABLE MODELS

M764

#### MATERIALS/PARTS

Three lockwashers  
 Two woodruff keys  
 Three cotter pins

#### REFERENCES (TM)

TM 9-2320-361-10  
 TM 9-2320-361-20P

#### EQUIPMENT CONDITION

- Parking brake set (TM 9-2320-361-10).
- Ž Earth boring machine seat frame removed (para. 12-92).

### NOTE

Maintenance procedures are the same for feed and drive levers.  
 This procedure covers the drive lever.

#### a. Removal

1. Remove nut (11), screw (17), and latch (16) from bracket (12).
2. Remove cotter pin (7), clevis pin (9), and clevis (8) from lever (10). Discard cotter pin (7).
3. Remove nut (21), screw (19), plate (20), and operating handle (22) from lever (10).
4. Remove three screws (14), lockwashers (13), and bracket (12) from main support tube (15). Discard lockwashers (13).
5. Loosen two screws (24) and remove two arms (25), rod (3), and two woodruff keys (23) from cams (18). Discard woodruff keys (23).

#### b. Disassembly

1. Remove two cotter pins (28) from shaft (27). Discard cotter pins (28).
2. Remove shaft (27), two bushings (26), and levers (10) from bracket (12).

#### NOTE

To maintain proper operation lever travel distance, note length of threads visible at each end of pushrod.

3. Remove two nuts (1), rod (3), two springs (2), and stop (4) from pushrod (5).
4. Remove clevis (8) and nut (6) from pushrod (5).

#### c. Assembly

#### NOTE

For steps 1 and 2, ensure visible threads match measurements noted in disassembly.

1. Install nut (6) and clevis (8) on pushrod (5).

**12-96. OPERATION LEVERS MAINTENANCE (Contd)**

2. Install stop (4), two springs (2), rod (3), and two nuts (1) on pushrod (5).
3. Install two levers (10), bushings (26), and shaft (27) on bracket (12).
4. Install two new cotter pins (28) in shaft (27).

**d. Installation**

1. Install new woodruff key (23) and arm (25) on cam (18). Tighten screw (24).
2. Install rod (3) in arm (25).
3. Install new woodruff key (23) and arm (25) on cam (18) and rod (3). Tighten screw (24).
4. Install bracket (12) on main support tube (15) with three new lockwashers (13) and screws (14).
5. Install clevis (8), clevis pin (9), and new cotter pin (7) on lever (10).
6. Install operating handle (22) on lever (10) with plate (20), screw (19), and nut (21).
7. Install latch (16) on bracket (12) with screw (17) and nut (11).

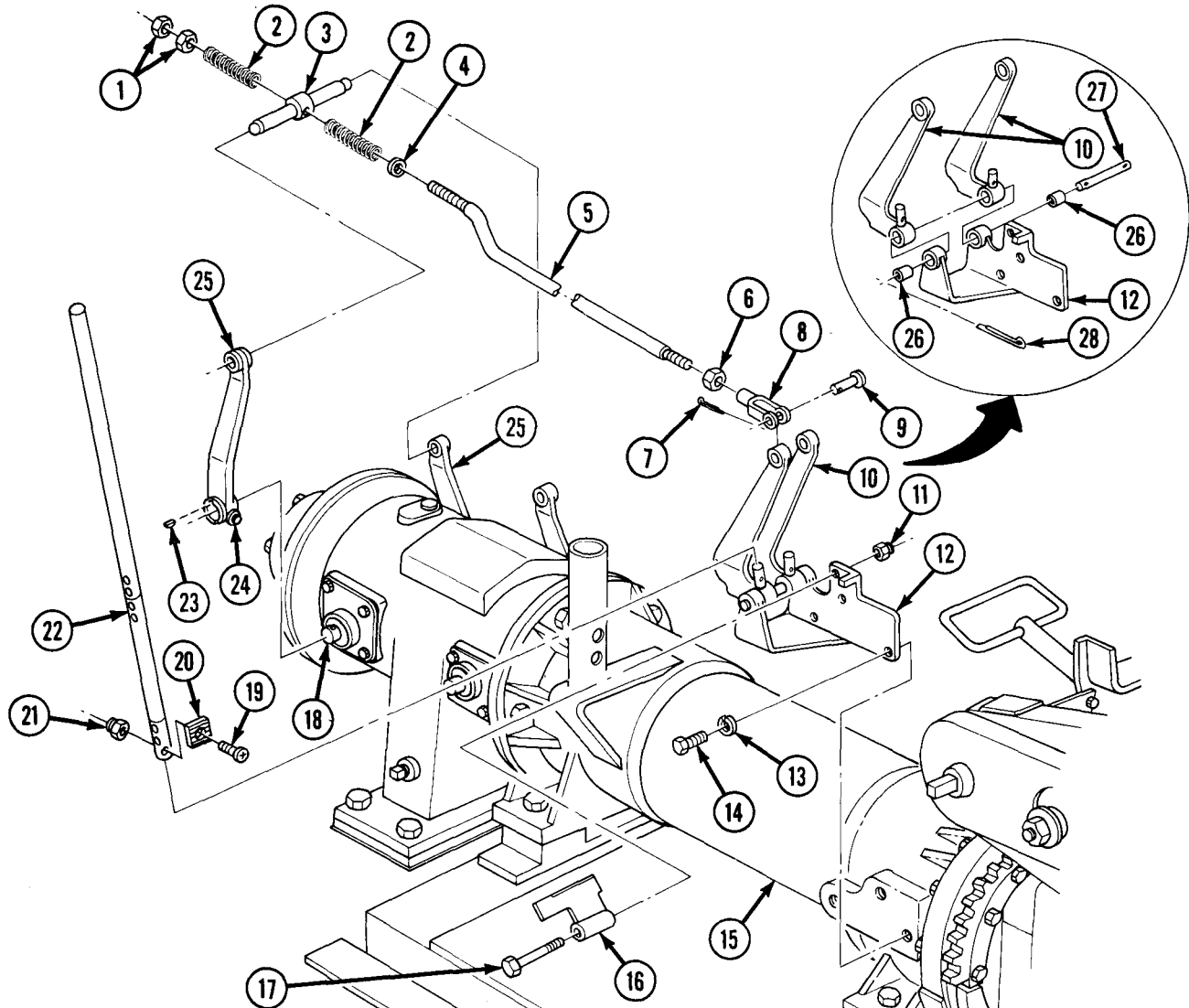

FOLLOW-ON TASK: Install earth boring machine seat frame (para. 12-92).



## 12-97. SNATCH SHEAVE MAINTENANCE

This task covers:

- |   |   |
|---|---|
| <ul style="list-style-type: none"> <li>a. Disassembly</li> <li>b. Inspection</li> </ul> | <ul style="list-style-type: none"> <li>c. Assembly</li> </ul> |
|---|---|

### INITIAL SETUP:

**APPLICABLE MODELS**

MT64

**REFERENCES (TM)**

TM 9-2320-361-20P

**MATERIALS/PARTS**

Safety wire (Appendix C, Item 22)  
Graphite grease (Appendix C, Item 15)

**EQUIPMENT CONDITION**

Snatch sheave removed (para. 12-98).

### a. Disassembly

1. Remove safety wire (4), screw (2), retaining pin (3), and pulley (7) from sheave housing (1). Discard safety wire (4).
2. Remove bearing sleeve (5) from pulley (7).

### b. Inspection

1. Clean all parts (para. 2-10).
2. Check pulley (7) and sheave housing (1) for damage. Replace pulley (7) and sheave housing (1) if damaged.
3. Check sleeve bearing (6) for nicks, cracks, burrs, or wear. Inside diameter should be no greater than 1.77 in. (45 mm). Raised metal can be removed with a fine mill file. Press sleeve bearing (6) out of pulley (7) and replace sleeve bearing (6) if worn or damaged.
4. Check bearing sleeve (5) for nicks, burrs, cracks, or wear. Outside diameter should be no less than 1.735 in. (44.1 mm). Raised metal can be removed with a fine mill file. Replace bearing sleeve (5) if worn or damaged.

### c. Assembly

1. Apply graphite grease inside sleeve bearing (6) and install bearing sleeve (5) in sleeve bearing (6).
2. Install pulley (7) in sheave housing (1).
3. Aline hole in bearing sleeve (5) with hole in sheave housing (1) and install retaining pin (3) in sheave housing (1).
4. Install screw (2) in sheave housing (1).
5. Aline hole in screw (2) with hole in sheave housing (1), and install new safety wire (4) in screw (2) and sheave housing (1).

**12-97. SNATCH SHEAVE MAINTENANCE (Contd)**

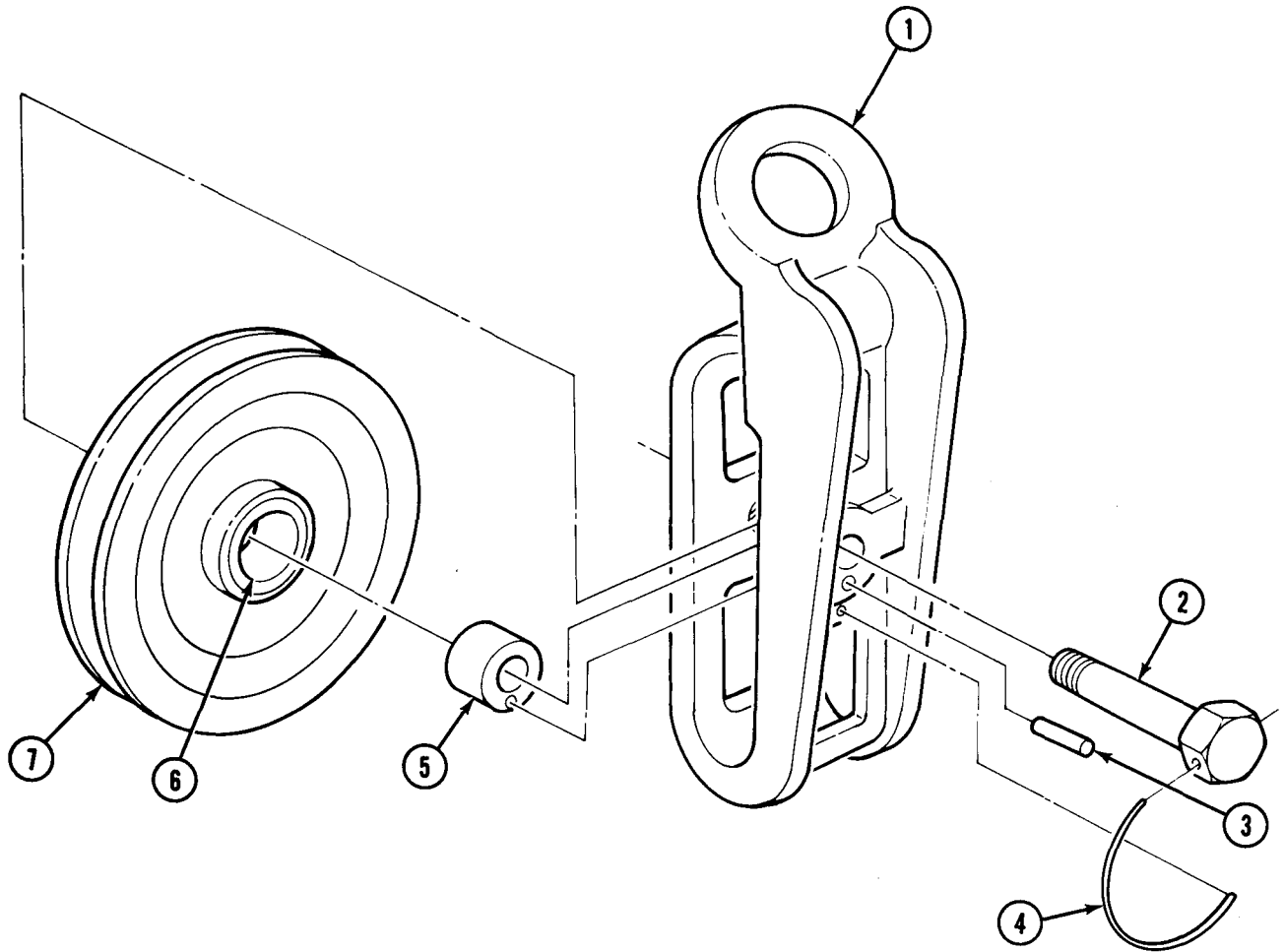

FOLLOW-ON TASK: Snatch sheave installed (para. 12-98).

## 12-98. SNATCH SHEAVE REPLACEMENT

This task covers:

a. Removal

b. Installation

### INITIAL SETUP:

#### APPLICABLE MODELS

M764

#### EQUIPMENT CONDITION

Parking brake set (TM 9-2320-361-10).

#### REFERENCES (TM)

TM 9-2320-361-10

TM 9-2320-361-20P

### a. Removal

1. Remove pin (1) from shackle (3) and derrick base (4).
2. Remove shackle (3) and snatch sheave (2) from derrick base (4).

### b. Installation

1. Install shackle (3) on snatch sheave (2).
2. Install shackle (3) and snatch sheave (2) to derrick base (4) with pin (1).

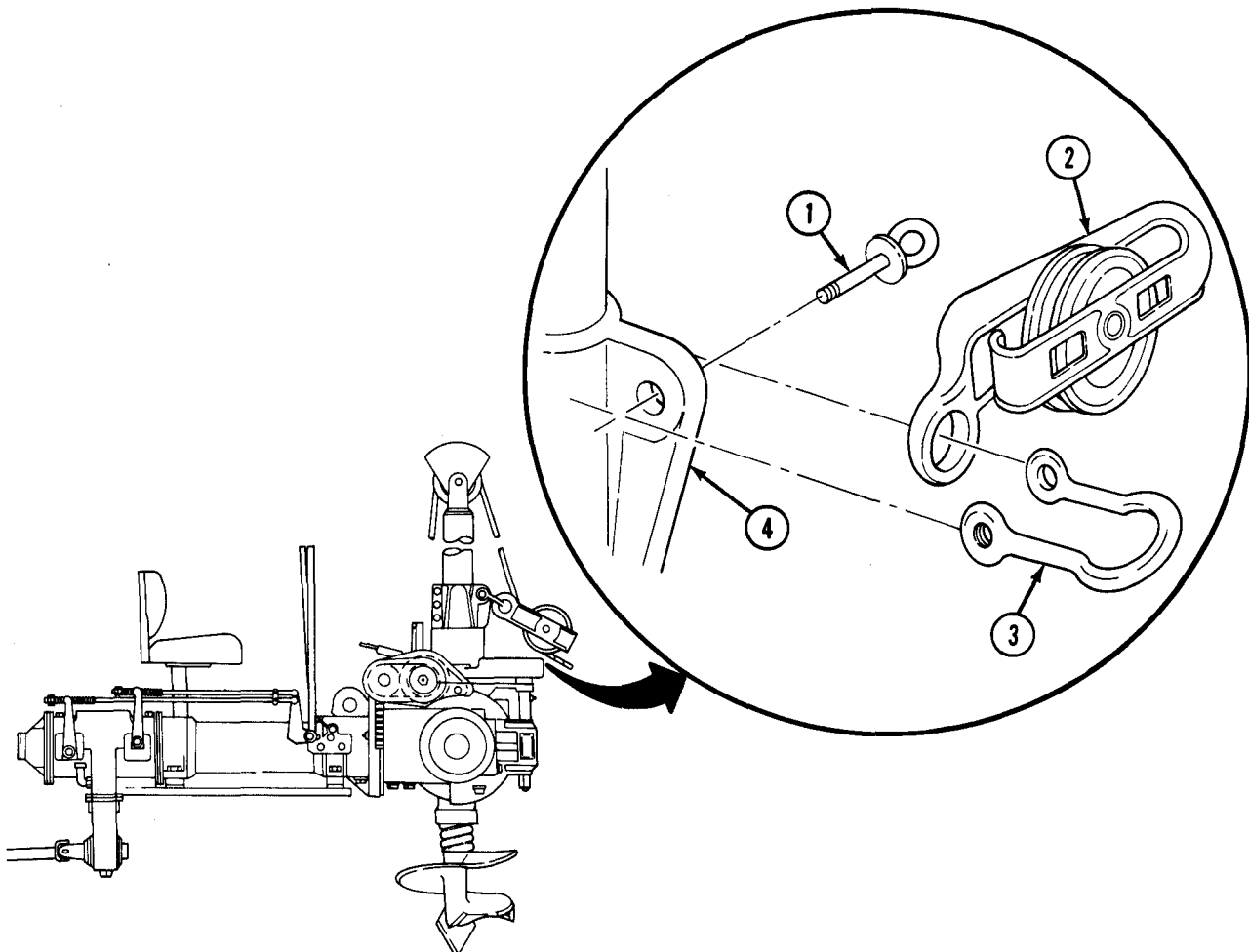

## Section VI. PIPELINE CONSTRUCTION BODY MAINTENANCE

**12-99. PIPELINE CONSTRUCTION BODY MAINTENANCE INDEX**

PARA, NO.	TITLE	PAGE NO.
12-100.	Gin Pole and Clamp Replacement	12-165
12-101.	Auxiliary Roller Replacement	12-167
12-102.	Front and Rear Splash Guard Replacement	12-168
12-103.	Stiff-Leg Jack Replacement	12-170
12-104.	Step Plate Replacement	12-171
12-105.	Pipeline Construction Cab Protector Replacement	12-172
12-106.	Pipeline Construction Toolbox Maintenance	12-174
12-107.	Pipeline Construction Tailgate Replacement	12-176

**12-100. GIN POLE AND CLAMP REPLACEMENT**

This task covers:

a. Removal

b. Installation

**INITIAL SETUP:****APPLICABLE MODELS**

M756A2

**MATERIALS/PARTS**

Three lockwashers  
Three cotter pins

**PERSONNEL REQUIRED**

Two

**REFERENCES (TM)**

LO 9-2320-209-12-1  
TM 9-2320-361-10  
TM 9-2320-361-20P

**EQUIPMENT CONDITION**

Parking brake set (TM 9-2320-361-10).

## 12-100. GIN POLE AND CLAMP REPLACEMENT (Contd)

### a. Removal

1. Remove two screws (11), lockwashers (10), and anchor pin (8) from rear roller bracket (7). Discard lockwashers(10).
2. Remove grease fitting (9) from anchor pin (8).

NOTE

Assistant will help with step 3.

3. Remove cotter pin (17), loosen wingnut (13), and remove gin pole (4) from clamp (20). Discard cotter pin (17).
4. Remove straight pin (3), straight pin (5), and boom link (6) from gin pole (4).
5. Remove wingnut (13), lockwasher (14), and washer (15) from eyebolt (18). Discard lockwasher (14).
6. Remove cotter pin (12), pin (19), and clamp bracket (16) from clamp (20). Discard cotter pin (12).
7. Remove cotter pin (1), pin (2), and eyebolt (18) from clamp (20). Discard cotter pin (1).

1. Install eyebolt (18) on clamp (20) with pin (2) and new cotter pin (1).
2. Install clamp bracket (16) on clamp (20) with pin (19) and new cotter pin (12).
3. Install washer (15), new lockwasher (14), and wingnut (13) on eyebolt (18).
4. Install boom link (6) on gin pole (4) with straight pin (5) and straight pin (3).

NOTE

Assistant will help with step 5.

5. Install gin pole (4) on clamp (20) and rear roller bracket (7). Tighten wingnut (13) and install new cotter pin (17).
6. Install boom link (6) on rear roller bracket (7) with anchor pin (8), two new lockwashers (10), and screws (11).
7. Install grease fitting (9) on anchor pin (8).

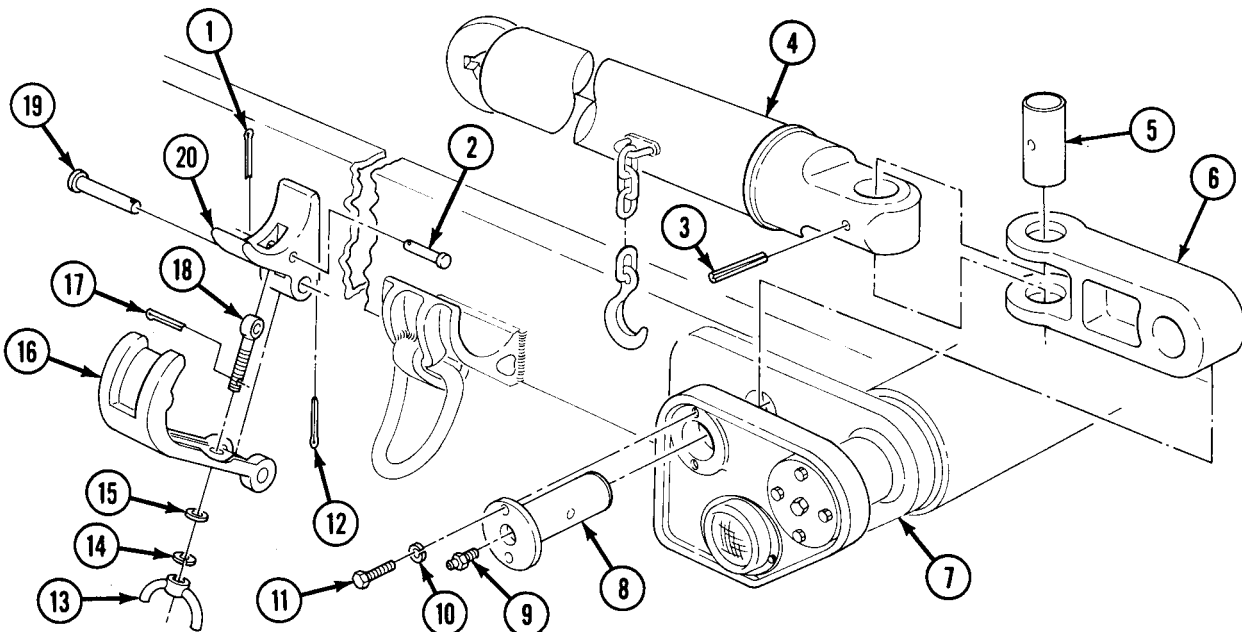

FOLLOW-ON TASK: Lubricate gin pole and clamp (LO 9-2320-209-12-1).

## 12-101. AUXILIARY ROLLER REPLACEMENT

This task covers:

### a. Removal

### b. Installation

INITIAL SETUP:

#### APPLICABLE MODELS

M756A2

#### MATERIALS/PARTS

Six locknuts

Two cotter pins

#### REFERENCES (TM)

LO 9-2320-209-12-1

TM 9-2320-361-10

TM 9-2320-361-20P

#### EQUIPMENT CONDITION

Parking brake set (TM 9-2320-361-10).

### a. Removal

1. Remove six locknuts (9), screws (8), and auxiliary roller bracket (3) from frame (10). Discard locknuts (9).
2. Remove two cotter pins (7), nuts (6), washers (5), roller shafts (2), and rollers (4) from auxiliary roller bracket (3). Discard cotter pins (7).
3. Remove grease fitting (1) from roller shafts (2).

### b. Installation

1. Install two rollers (4) on auxiliary roller bracket (3) with two roller shafts (2), washers (5), nuts (6), and new cotter pins (7).
2. Install grease fitting (1) on roller shafts (2).
3. Install auxiliary roller bracket (3) on frame (10) with six screws (8) and new locknuts (9).

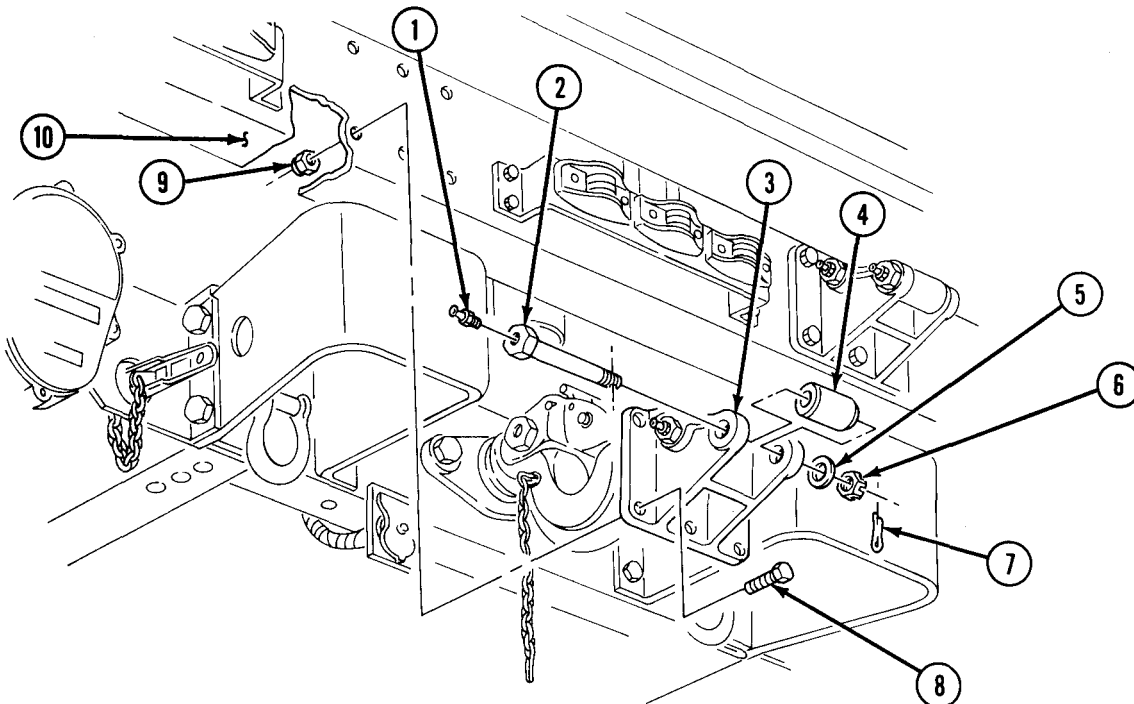

FOLLOW-ON TASK: Lubricate auxiliary rollers (LO 9-2320-209-12-1).

## 12-102. FRONT AND REAR SPLASH GUARD REPLACEMENT

This task covers:

- |   |   |
|---|---|
| a. Front Splash Guard Removal<br>b. Rear Splash Guard Removal | c. Rear Splash Guard Installation<br>d. Front Splash Guard Installation |
|---|---|

### INITIAL SETUP:

**APPLICABLE MODELS**

M756A2

**MATERIALS/PARTS**

Eleven locknuts

**REFERENCES (TM)**

TM 9-2320-361-10

TM 9-2320-361-20P

**EQUIPMENT CONDITION**

Parking brake set (TM 9-2320-361-10).

### a. Front Splash Guard Removal

NOTE

- Left and right front splash guards are removed the same, except for fuel tank brace on left side. This procedure is for the right front splash guard.
- Perform steps 1 and 2 if brace is damaged and requires replacement.

1. Remove fuel tank (para. 3-24).
2. Remove locknut (2), screw (5), and brace (4) from fuel tank support (3). Discard locknut (2).
3. Remove locknut (6), screw (8), and brace (4) from splash guard (7). Discard locknut (6).
4. Remove two locknuts (10), screws (9), and splash guard (7) from toolbox (1). Discard locknuts (10).

### b. Rear Splash Guard Removal

NOTE

Left and right rear splash guards are removed the same. This procedure is for the right rear splash guard.

1. Remove two locknuts (18) and (16), screws (19) and (14), and brace (17) from frame (15) and splash guard (20). Discard locknuts (18) and (16).
2. Remove two locknuts (13), screws (12), and splash guard (20) from mounting bracket (22). Discard locknuts (13). Discard locknuts (13).
3. Remove three locknuts (21), screws (23), and mounting bracket (22) from frame (11). Discard locknuts (21).

### c. Rear Splash Guard Installation

NOTE

Left and right splash guards are installed the same. This procedure is for the right rear splash guard.

1. Install mounting bracket (22) on frame (11) with three screws (23) and new locknuts (21).
2. Install splash guard (20) on mounting bracket (22) with two screws (12) and new locknuts (13).
3. Install brace (17) on splash guard (20) and frame (15) with two screws (14) and (19) and new locknuts (16) and (18).

**12-102. FRONT AND REAR SPLASH GUARD REPLACEMENT (Contd)**

**d. Front Splash Guard Installation**

NOTE

- Left and right front splash guards are installed the same, except for fuel tank brace on left side. This procedure is for the right front splash guard.
- Perform steps 1 and 2 if brace was removed.

1. Install brace (4) on fuel tank support (3) with screw (5) and new locknut (2).
2. Install fuel tank (para. 3-24).
3. Install splash guard (7) on toolbox (1) with two screws (9) and new locknuts (10).
4. Install brace (4) on splash guard (7) with screw (8) and new locknut (6).

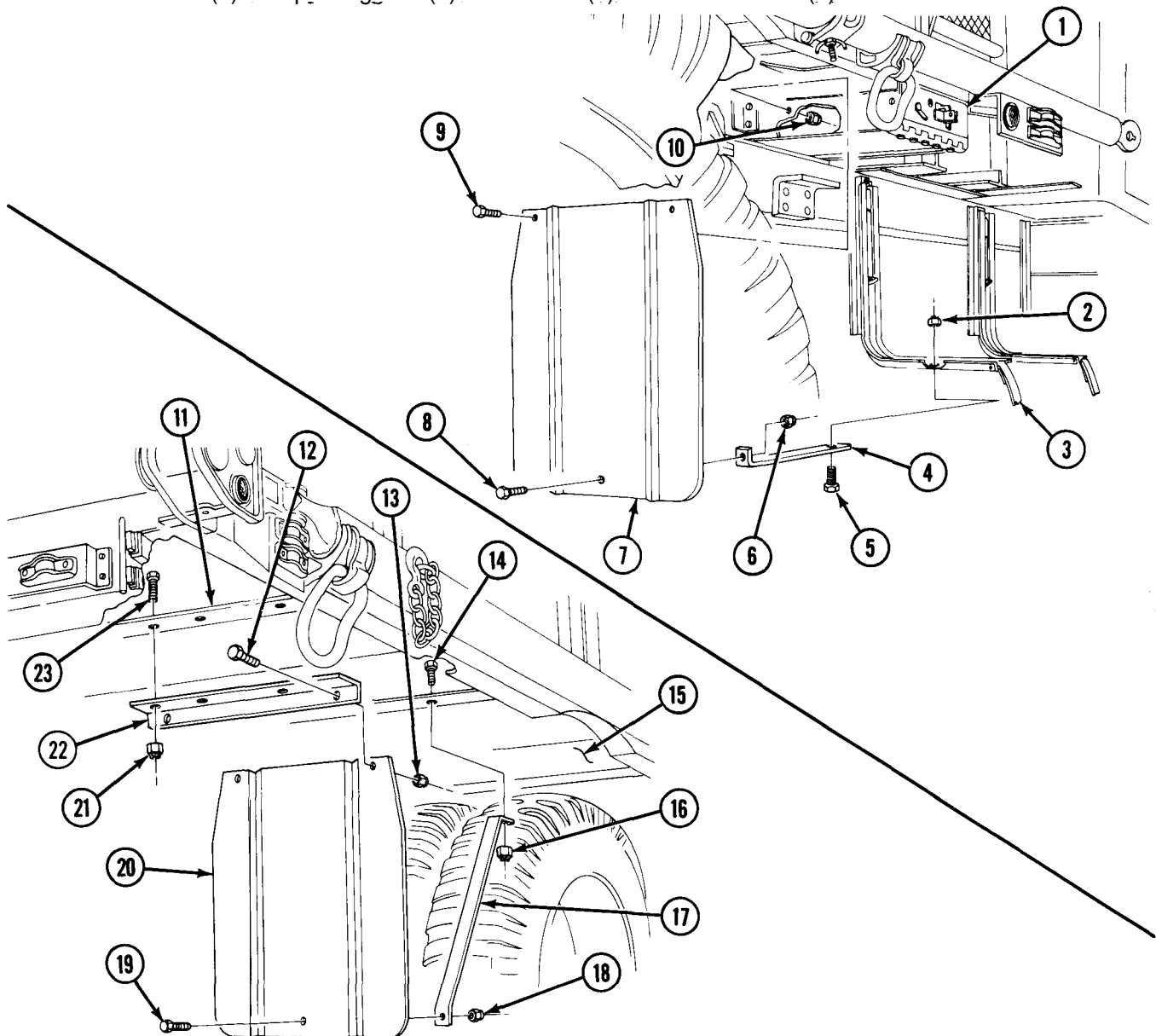



## 12-103. STIFF-LEG JACK REPLACEMENT

This task covers:

a. Removal

b. Installation

### INITIAL SETUP:

#### APPLICABLE MODELS

M756A2

#### REFERENCES (TM)

TM 9-2320-361-10

TM 9-2320-361-20P

#### MATERIALS/PARTS

Two cotter pins

GAA grease (Appendix C, Item 13)

#### EQUIPMENT CONDITION

Parking brake set (TM 9-2320-361-10).

### a. Removal

1. Remove locking clip (8) and tee handle (13) from upper leg (6) and lower leg (12).
2. Slide upper leg (6) and lower leg (12) from stiff-leg jack housing (3) and remove lower leg (12) from upper leg (6).
3. Remove three hooks (5) from tee handle (13), upper leg (6), locking clip (8), and chain (7).
4. Remove cotter pin (4), straight pin (1), and upper leg (6) from mounting tube (2). Discard cotter pin (4).
5. Remove cotter pin (9), straight pin (11), and foot (10) from lower leg (12). Discard cotter pin (9).

### b. Installation

1. Install foot (10) on lower leg (12) with straight pin (11) and new cotter pin (9).
2. Install chain (7) on tee handle (13), locking clip (8), and upper leg (6) with three hooks (5).
3. Install upper leg (6) on mounting tube (2) with straight pin (1) and new cotter pin (4), and slide into stiff-leg housing (3).
4. Apply light coat of GAA grease into upper leg (6) and on lower leg (12).
5. Install lower leg (12) in upper leg (6) with tee handle (13) and locknut clip (8).

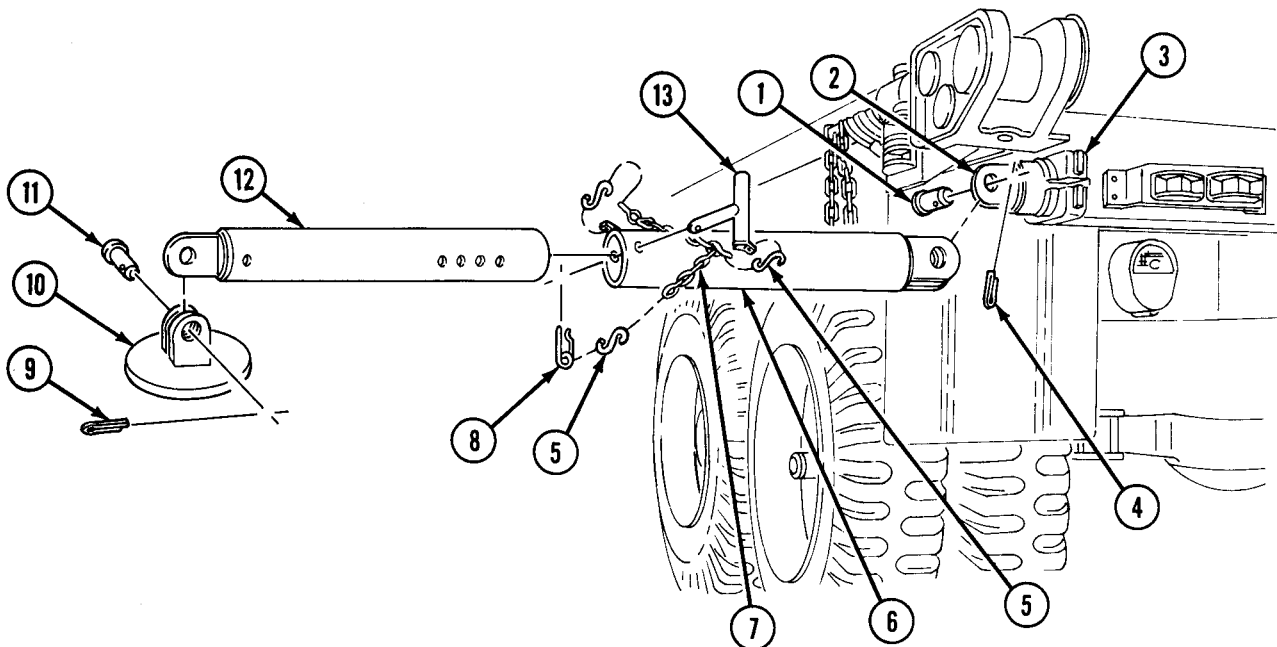

## 12-104. STEP PLATE REPLACEMENT

This task covers:

a. Removal

b. Installation

### INITIAL SETUP:

#### APPLICABLE MODELS

M756A2

#### MATERIALS/PARTS

Four locknuts

#### REFERENCES (TM)

TM 9-2320-361-10

TM 9-2320-361-20P

#### EQUIPMENT CONDITION

Parking brake set (TM 9-2320-361-10).

### a. Removal

Remove four locknuts (6), screws (3), washers (4), and step (2) from toolbox (1) and cab protector (5). Discard locknuts (6).

### b. Installation

Install step (2) on cab protector (5) and toolbox (1) with four washers (4), screws (3), and new locknuts (6).

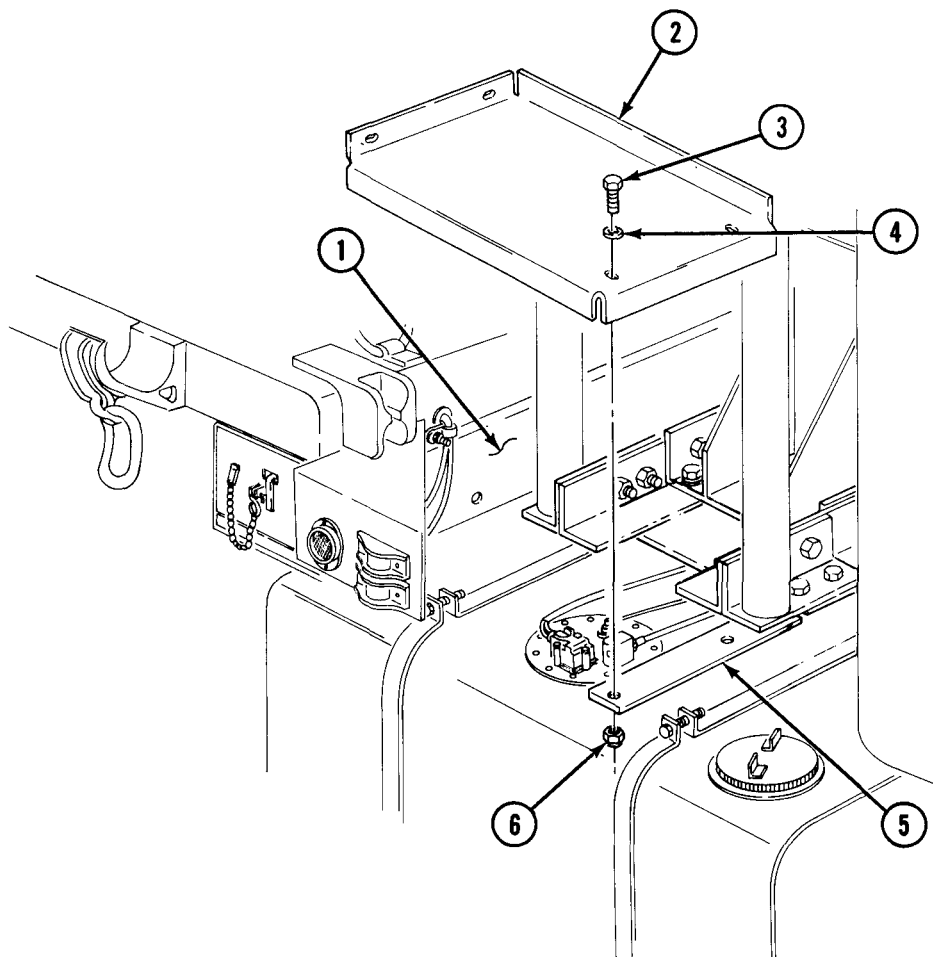

**12-105. PIPELINE CONSTRUCTION CAB PROTECTOR REPLACEMENT**

This task covers:

a. Removal

b. Installation

**INITIAL SETUP:**

**APPLICABLE MODELS**

M756A2

**MATERIALS/PARTS**

Twenty locknuts

**PERSONNEL REQUIRED**

Two

**REFERENCES (TM)**

TM 9-2320-361-10

TM 9-2320-361-20P

**EQUIPMENT CONDITION**

- Parking brake set (TM 9-2320-361-10).
- Floodlight and brackets removed (para. 4-43).
- Clearance marker lights and brackets removed (para. 4-45).
- Cab protector wiring harness removed (para. 4-52).
- Rear winch drum clutch lever and guide plate removed (para. 13-9).
- Step plate removed (para. 12-104).

**GENERAL SAFETY INSTRUCTIONS**

All personnel must stand clear during lifting operations.

**WARNING**

All personnel must stand clear during lifting operations. A swinging or shifting load may result in injury to personnel.

**a. Removal**

1. Remove four locknuts (11), screws (3), and tool bracket (12) from cab protector (13). Discard locknuts (11).
2. Secure chain sling (1) to cab protector (13) and lifting device (2). Raise lifting device (2) enough to remove slack from chain sling (1).
3. Remove eight locknuts (8), washers (7), and screws (4) from cab protector (13) and four brackets (6). Discard locknuts (8).
4. Remove eight locknuts (9) and screws (10) from cab protector (13) and two winch supports (5). Discard locknuts (9).

**NOTE**

Assistant will help with step 5.

5. Remove cab protector (13) with lifting device (2) from two winch supports (5) and four brackets (6).
6. Remove chain sling (1) from cab protector (13).

**b. Installation**

**NOTE**

Assistant will help with step 1.

1. Secure chain sling (1) to cab protector (13), and install cab protector (13) on two winch supports (5) and four brackets (6) with lifting device (2).
2. Install eight screws (10) and new locknuts (9) on two winch supports (5) and cab protector (13).
3. Install eight screws (4), washers (7), and new locknuts (8) on four brackets (6) and cab protector (13).
4. Remove chain sling (1) from cab protector (13).
5. Install tool bracket (12) on cab protector (13) with four screws (3) and new locknuts (11).

## 12-105. PIPELINE CONSTRUCTION CAB PROTECTOR REPLACEMENT (Contd)

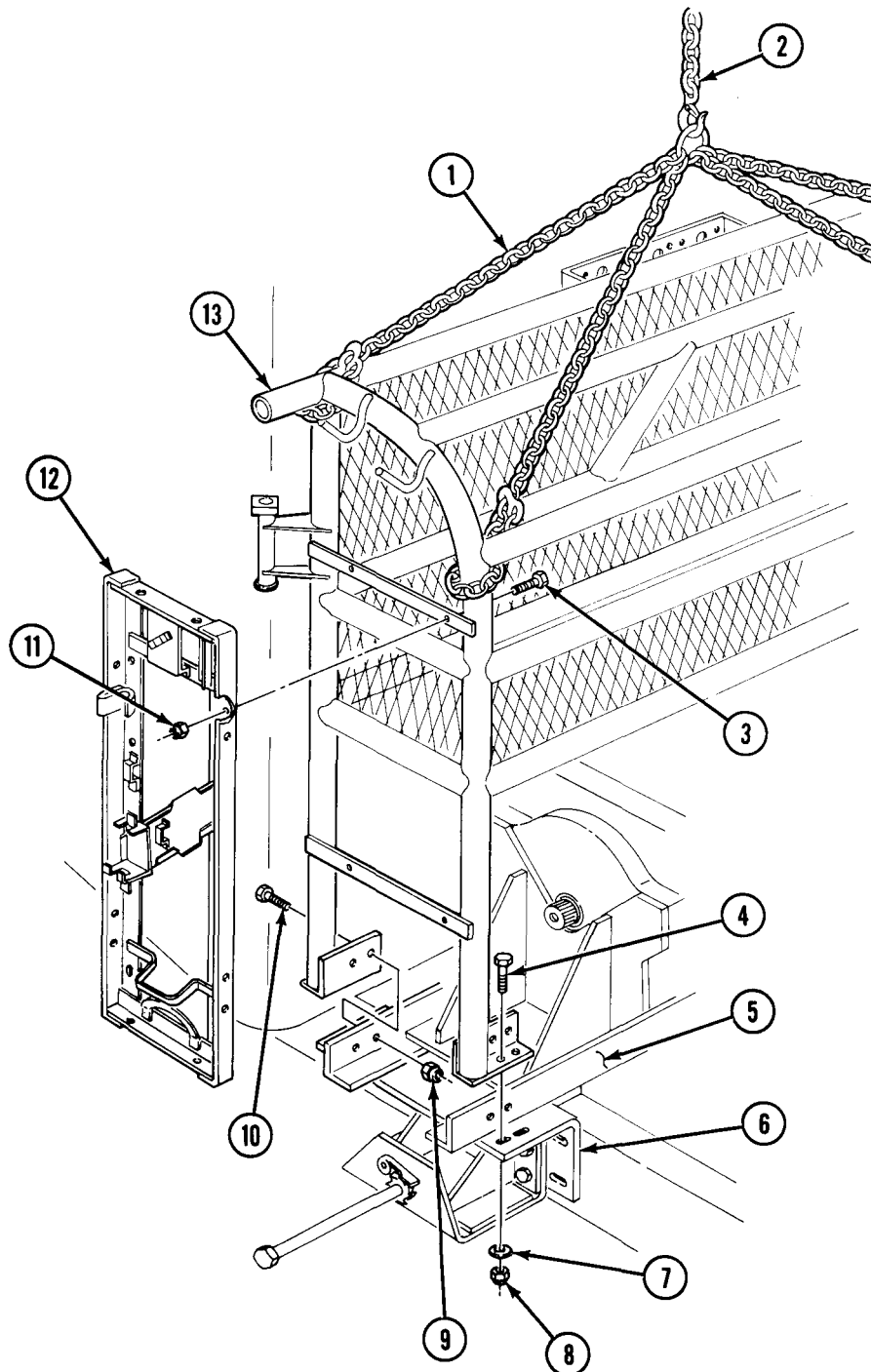

- FOLLOW-ON TASKS:
- Install step plate (para. 12-104).
  - Install rear winch drum clutch lever and guide plate (para. 13-9).
  - Install cab protector wiring harness (para. 4-52).
  - Install clearance marker lights and brackets (para. 4-45).
  - Install floodlights and brackets (para. 4-43).

## 12-106. PIPELINE CONSTRUCTION TOOLBOX MAINTENANCE

This task covers:

- a. Disassembly
- b. Inspection
- c. Assembly

### INITIAL SETUP:

#### APPLICABLE MODELS

M756A2 W/W

#### MATERIALS/PARTS

Fourteen locknuts

#### PERSONNEL REQUIRED

Two

#### REFERENCES (TM)

TM 9-2320-361-10

TM 9-2320-361-20P

#### EQUIPMENT CONDITION

Parking brake set (TM 9-2320-361-10).

### a. Disassembly

1. Remove toolbox floor (1) from toolbox (2).
2. Remove ten locknuts (8), screws (3), two spacers (4), door (5), and door (10) from toolbox (2). Discard locknuts (8).
3. Remove four locknuts (14), screws (11), two straps (12), and plates (13) from door (5) and door (10). Discard locknuts (14).
4. Remove two S-hooks (7) and padlocks with chains (9) from two door brackets (6).

### b. Inspection

Inspect toolbox floor (1) for splits and cracks. If split or cracked, replace toolbox floor (1).

### c. Assembly

1. Install two S-hooks (7) and padlocks with chains (9) on two door brackets (6).
2. Install two plates (13) and straps (12) on door (5) and door (10) with four screws (11) and new locknuts (14).
3. Install two spacers (4), door (5), and door (10) on toolbox (2) with ten screws (3) and new locknuts (8).

12-106. PIPELINE CONSTRUCTION TOOLBOX MAINTENANCE (Contd)

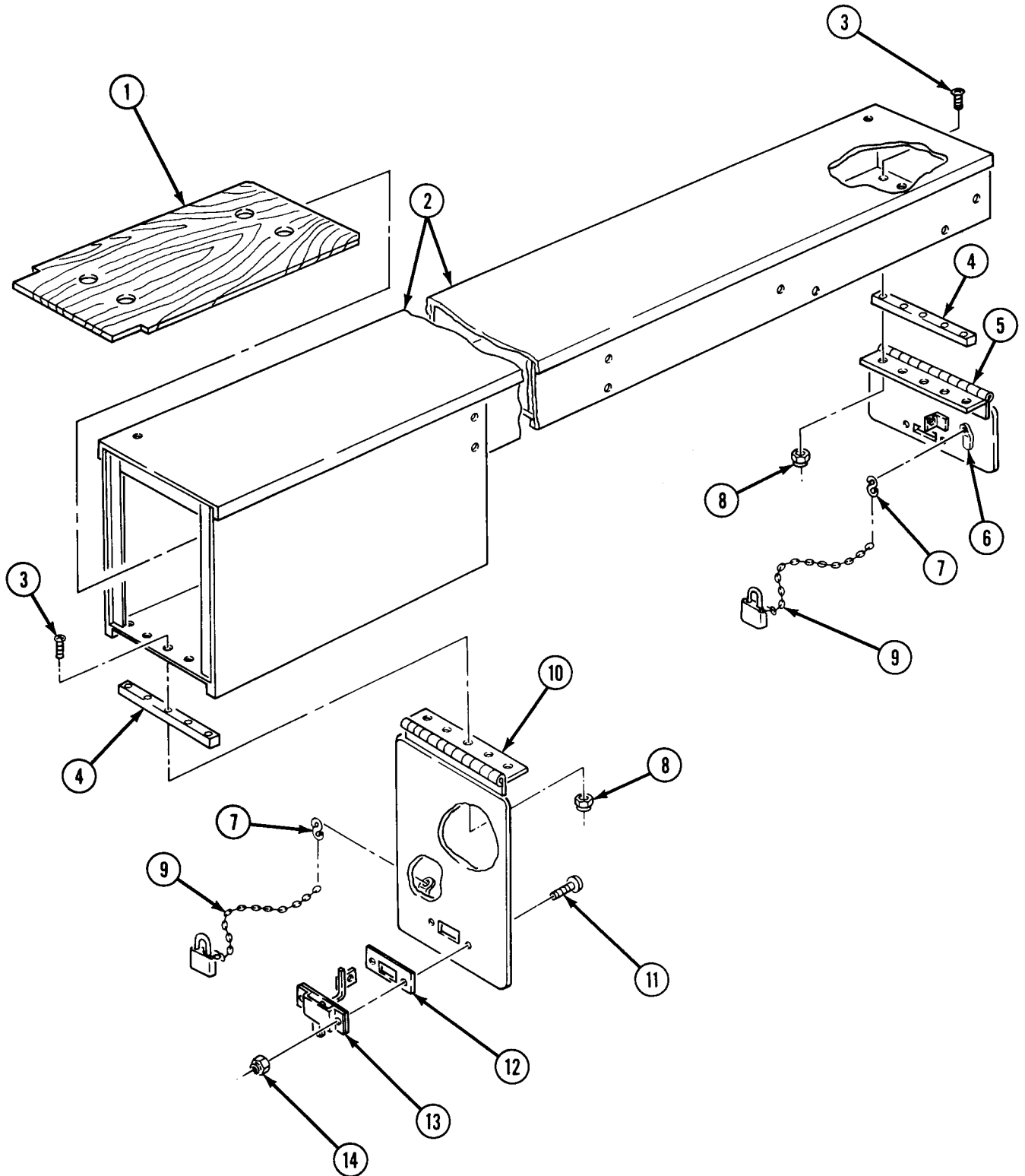

**12-107. PIPELINE CONSTRUCTION TAILGATE REPLACEMENT**

This task covers:

- a. Removal
- b. Installation

**INITIAL SETUP:**

APPLICABLE MODELS

M756A2

MATERIALS/PARTS

Six locknuts

PERSONNEL REQUIRED

Two

REFERENCES (TM)

TM 9-2320-361-10

TM 9-2320-361-20P

EQUIPMENT CONDITION

Parking brake set (TM 9-2320-361-10).

GENERAL SAFETY INSTRUCTIONS

Tailgate is heavy. Be prepared to support tailgate weight prior to removing screws.

**a. Removal**

1. Remove four locknuts (3), screws (4), and two steps (5) from tailgate (6). Discard locknuts (3).
2. Disconnect two safety chains (1) from tailgate (6) and lower tailgate (6).

WARNING

Tailgate is heavy. Ensure tailgate is supported prior to removing screws. Failure to do so may cause injury to personnel.

NOTE

Assistant will help with steps 3 and 4.

3. Remove two locknuts (8) and screws (2) from tailgate (6). Discard locknuts (8).
4. Remove tailgate (6) from body (7).

**b. Installation**

1. Install two steps (5) on tailgate (6) with four screws (4) and new locknuts (3).
2. Install tailgate (6) on body (7) with two screws (2) and new locknuts (8).
3. Connect two safety chains (1) on tailgate (6).

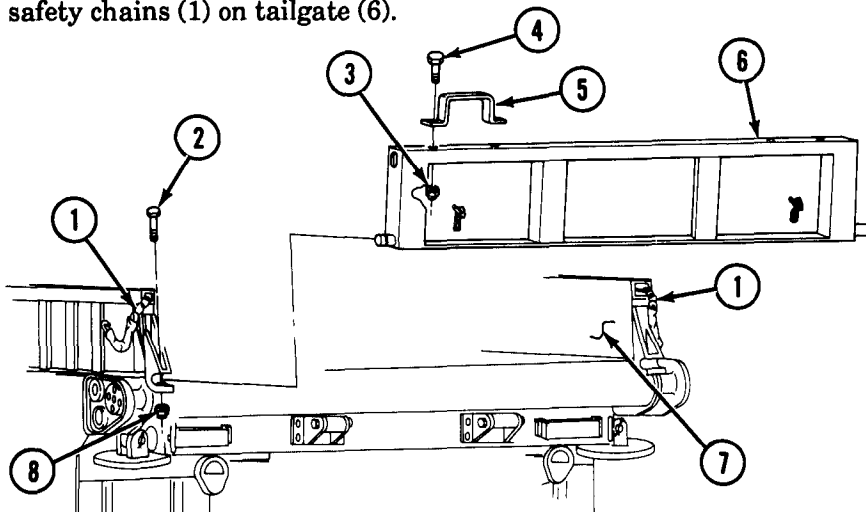

## Section VII. TRACTOR MAINTENANCE

**12-108. TRACTOR MAINTENANCE INDEX**

PARA. NO.	TITLE	PAGE NO.
12-109.	Rear Splash Guard Replacement	12-177
12-110.	Front and Rear Deck Replacement	12-178
12-111.	Toolbox Replacement	12-180
12-112.	Fifth Wheel Replacement	12-181

**12-109. REAR SPLASH GUARD REPLACEMENT**

This task covers:

a. Removal

b. Installation

**INITIAL SETUP:****APPLICABLE MODELS**

M275A2

**MATERIALS/PARTS**

Ten locknuts

**REFERENCES (TM)**

TM 9-2320-361-10

TM 9-2320-361-20P

**EQUIPMENT CONDITION**

Parking brake set (TM 9-2320-361-10).

**a. Removal**

1. Remove six locknuts (4), screws (6), and bracket (5) from splash guard (2) and plate (7). Discard locknuts (4).
2. Remove four locknuts (3), screws (1), and splash guard (2) from plate (7). Discard 10 locknuts (3).

**b. Installation**

1. Install splash guard (2) on plate (7) with four screws (1) and new locknuts (3).
2. Install brace (5) on plate (7) and splash guard (2) with six screws (6) and new locknuts (4).

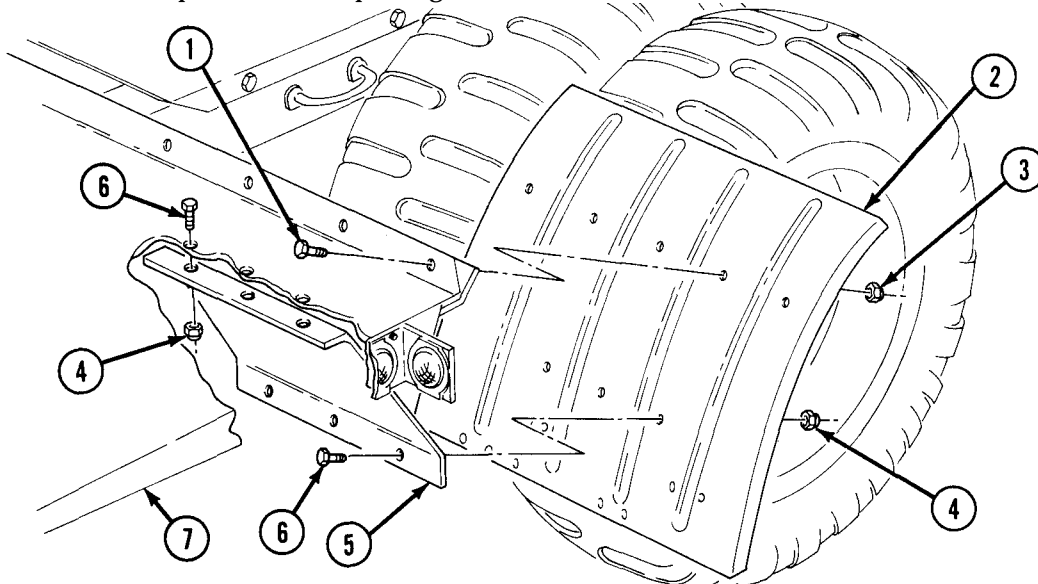



12-110. FRONT AND REAR DECK REPLACEMENT

This task covers:

- |                       |                            |
|-----------------------|----------------------------|
| a. Rear Deck Removal  | c. Front Deck Installation |
| b. Front Deck Removal | d. Rear Deck Installation  |

INITIAL SETUP:

APPLICABLE MODELS  
M275A2

MATERIALS/PARTS  
Twenty-six locknuts

PERSONNEL REQUIRED  
Two

REFERENCES (TM)  
TM 9-2320-361-10  
TM 9-2320-361-20P

EQUIPMENT CONDITION

- Parking brake set (TM 9-2320-361-10).
- Toolbox removed (para. 12-111).
- Water can bracket removed (para. 11-24).
- Rear splash guards removed (para. 12-109).

**a. Rear Deck Removal**

Remove six locknuts (12), screws (10), and rear deck (9) from frame (11). Discard locknuts (12).

**b. Front Deck Removal**

1. Remove three locknuts (8), screws (7), and support (6) from front deck (4). Discard locknuts (8).
2. Remove four locknuts (5), screws (2), and angle (3) from front deck (4). Discard locknuts (5).
3. Remove eight locknuts (14) and screws (18) from angle brackets (15) and front deck (4). Discard locknuts (14).
4. Remove locknut (17) and screw (19) from clamp (16) and front deck (4).

CAUTION

Raise mast hose support only as high as necessary to remove front deck. Raising mast hose too high will result in damage to air hoses.

NOTE

Assistant will help with steps 5 and 6.

5. Remove four locknuts (20) and screws (1), and raise mast hose support (13) from front deck (4). Discard locknuts (20).
6. While supporting mast hose support (13), remove front deck (4) from four angle brackets (15).

**c. Front Deck Installation**

CAUTION

Raise mast hose support only as high as necessary to install front deck. Raising mast hose too high will result in damage to air hose.

NOTE

Assistant will help with step 1.

1. While supporting mast hose support (13), install front deck (4) on four angle brackets (15).
2. Install mast hose support (13) on deck plate (4) with four screws (1) and new locknuts (20).
3. Install clamp (16) on front deck (4) with screw (19) and new locknut (17).

## 12-110. FRONT AND REAR DECK REPLACEMENT (Contd)

4. Install eight screws (18) and new locknuts (14) on deck plate (4) and four angle brackets (15).
5. Install angle bracket (3) on front deck (4) with four screws (2) and new locknuts (5).
6. Install support (6) on front deck (4) with three screws (7) and new locknuts (8).

### d. Rear Deck Installation

Install rear deck (9) on frame (11) with six screws (10) and new locknuts (12).

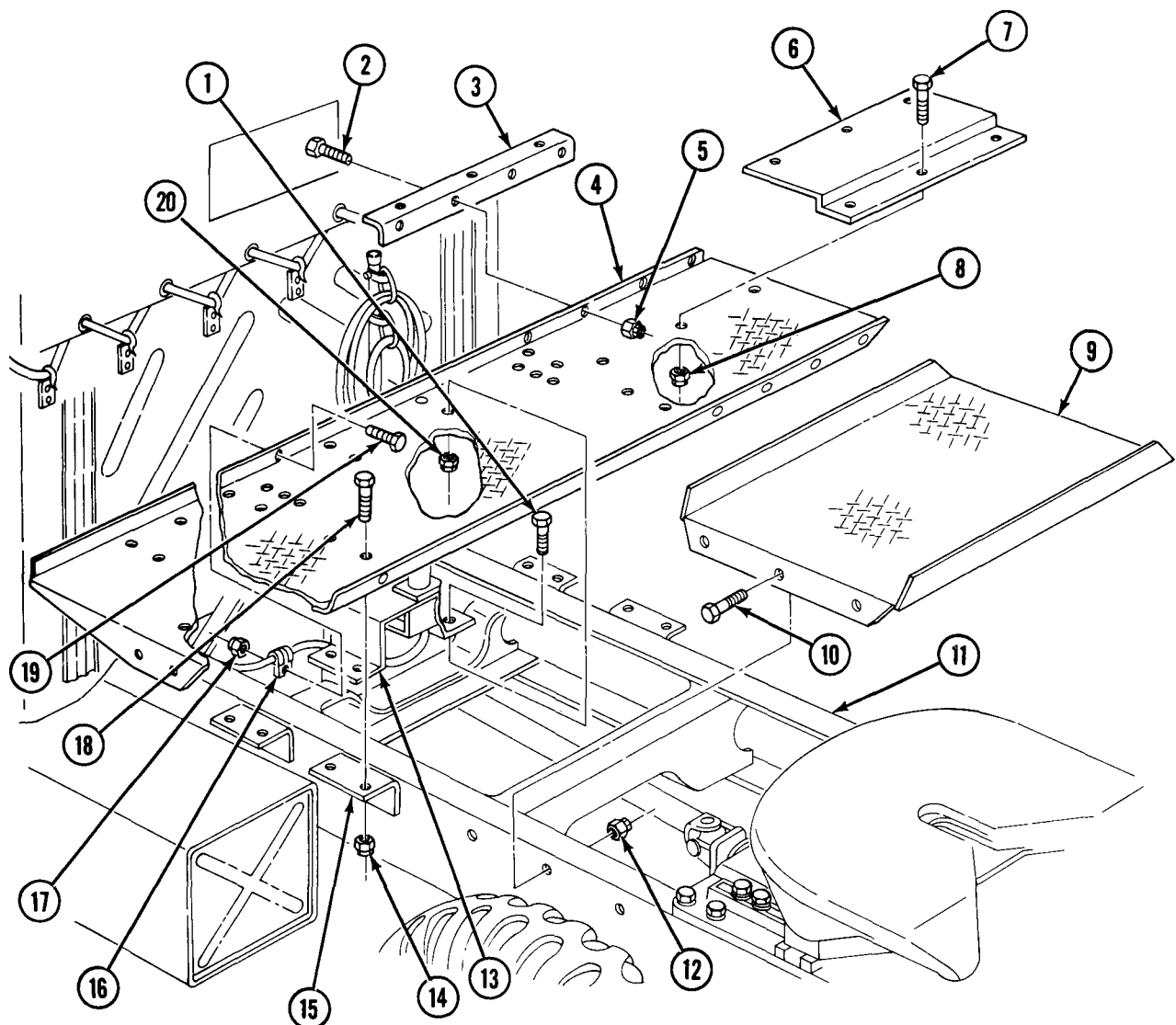

- FOLLOW-ON TASKS:
- Install toolbox (para. 12-111).
  - Install water can bracket (para. 11-24).
  - Install rear splash guards (para. 12-109).

12-111. TOOLBOX REPLACEMENT

This task covers:

a. Removal

b. Installation

INITIAL SETUP:

APPLICABLE MODELS  
M275A2

REFERENCES (TM)  
TM 9-2320-361-10  
TM 9-2320-361-20P

MATERIALS/PARTS  
Three locknuts

EQUIPMENT CONDITION  
Parking brake set (TM 9-2320-361-10).

**a. Removal**

1. Remove three screws (9) and washers (8) from weld nuts (7) and support (6).
2. Remove three locknuts (5), washers (3), screws (2), and toolbox (1) from support (6) and angle (4). Discard locknuts (6).

**b. Installation**

1. Install toolbox (1) on support (6) and angle (4) with three screws (2), washers (3), and new locknuts (5).
2. Install three washers (8) and screws (9) on weld nuts (7) and support (6).

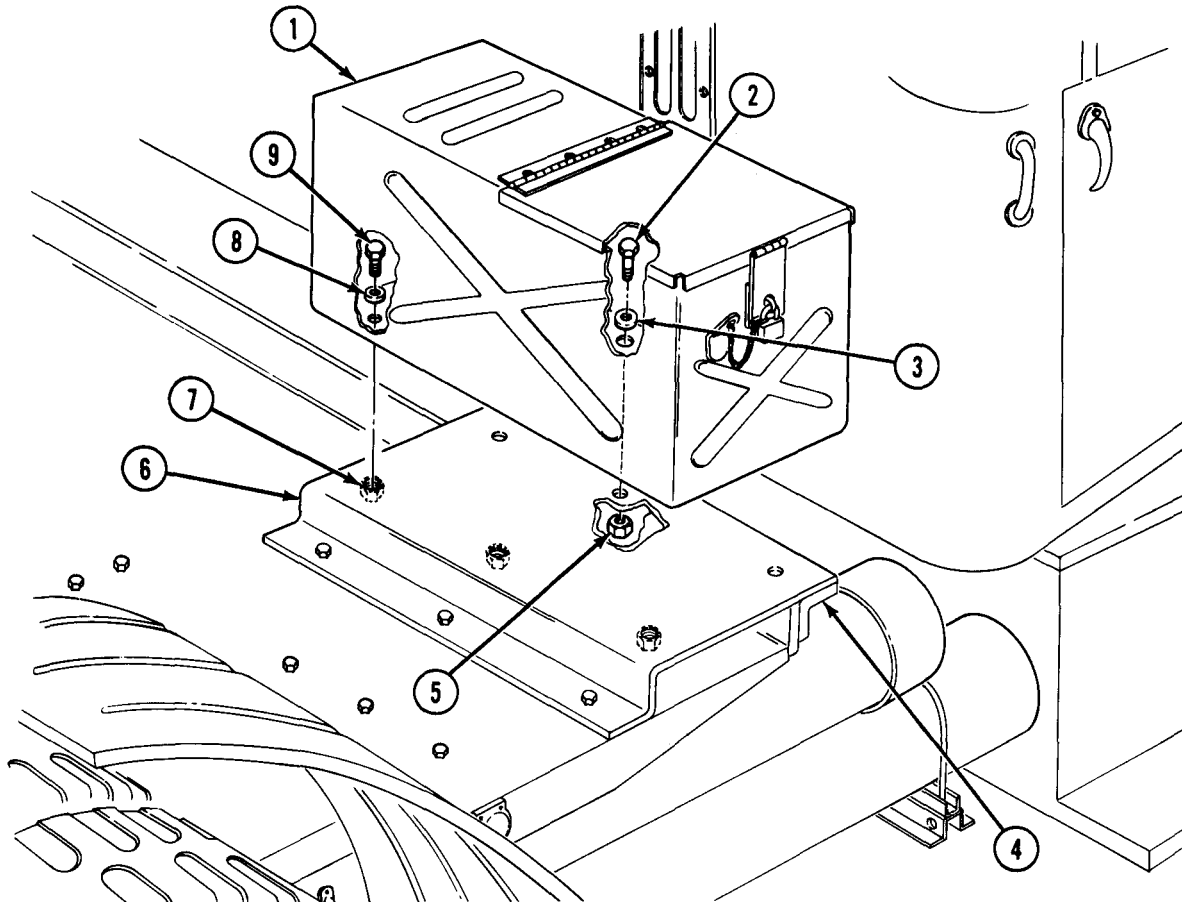

12-112. FIFTH WHEEL REPLACEMENT

This task covers:

a. Removal

b. Installation

INITIAL SETUP:

APPLICABLE MODELS  
M275A2

MATERIALS/PARTS  
Ten locknuts

PERSONNEL REQUIRED  
Two

REFERENCES (TM)  
LO 9-2320-209-12-1  
TM 9-2320-361-10  
TM 9-2320-361-20P

EQUIPMENT CONDITION  
Parking brake set (TM 9-2320-361-10).

GENERAL SAFETY INSTRUCTIONS  
All personnel must stand clear during lifting operations.

**a. Removal**

1. Remove ten locknuts (9), twenty washers (10), and ten screws (11) from fifth wheel subbase (5) and frame rails (7). Discard locknuts (9).
2. Attach utility chain (4) to fifth wheel (1) with four washers (2), two screws (6), and nuts (3).

**WARNING**

All personnel must stand clear during lifting operations. A swinging or shifting load may result in injury to personnel.

**NOTE**

Assistant will help with step 3.

3. Remove fifth wheel (1) and two spacers (8) from frame rails (7).
4. Remove two nuts (3), four washers (2), two screws (7), and chain (4) from fifth wheel (1).

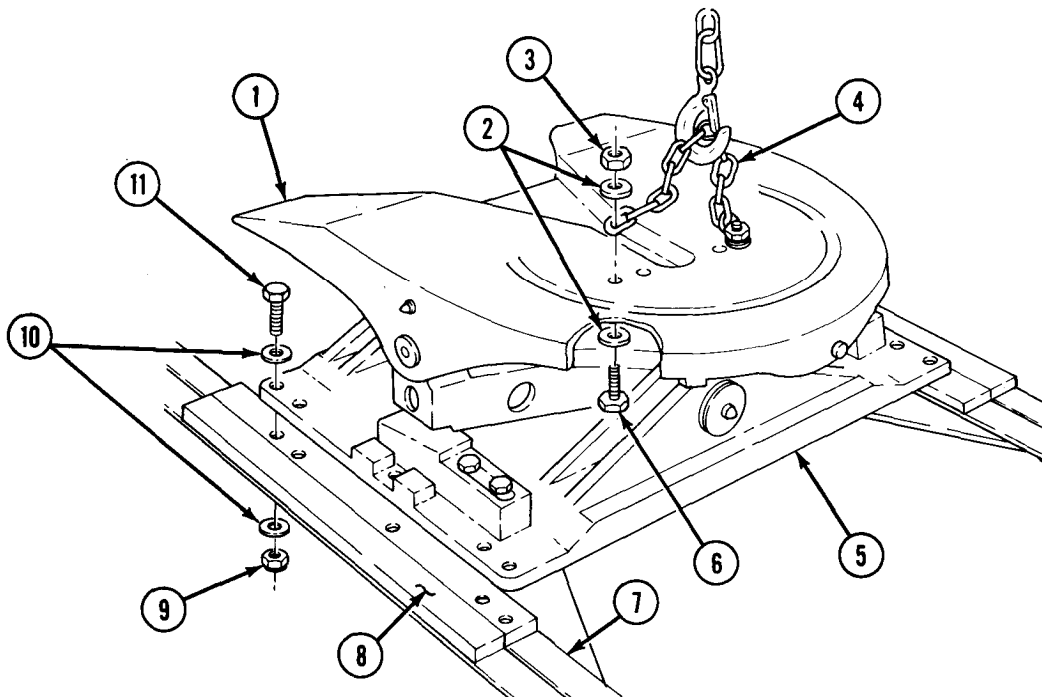

**12-112. FIFTH WHEEL REPLACEMENT (Contd)**

**b. Installation**

1. Attach utility chain (4) to fifth wheel (1) with four washers (2), two screws (6), and nuts (3).

NOTE

Assistant will help with step 2.

2. Install two spacers (8) and fifth wheel subbase (5) on frame rails (7) with twenty washers (10), ten screws (11), and new locknuts (9). Tighten locknuts (9) 125-150 lb-ft (170-203 N $\bar{m}$ ).
3. Remove two nuts (3), four washers (2), two screws (6), and chain (4) from fifth wheel (1).

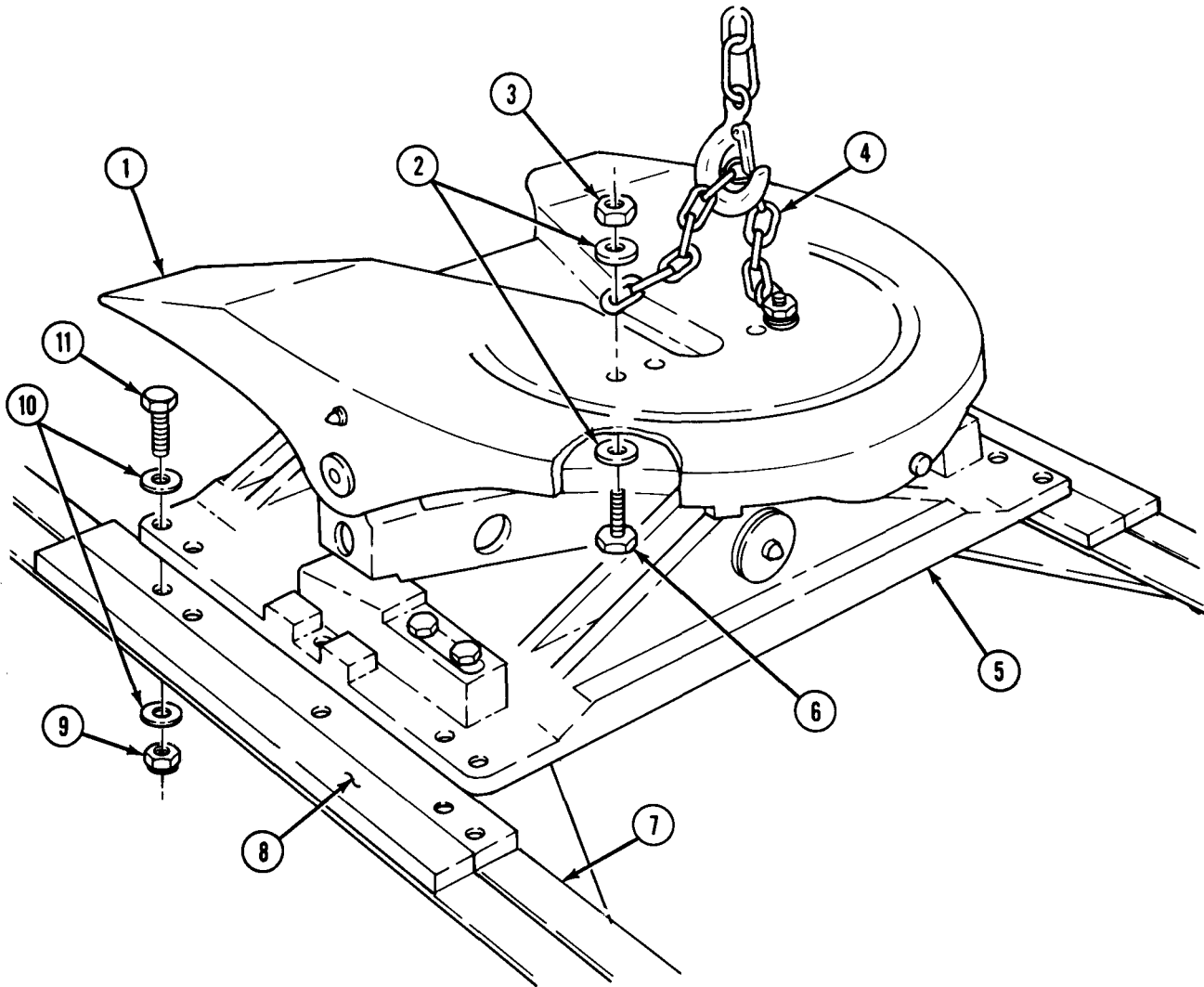

FOLLOW-ON TASK: Lubricate fifth wheel (LO 9-2320-209-12-1).

## CHAPTER 13

## WINCH AND POWER TAKEOFF MAINTENANCE

Section I. Winch Maintenance (page 13-1)

Section II. Power Takeoff Controls and Linkage Maintenance (page 13-34)

## Section 1. WINCH MAINTENANCE

## 13-1. WINCH MAINTENANCE INDEX

PARA. NO.	TITLE	PAGE NO.
13-2.	Front Winch Drag Brake Test and Adjustment	13-2
13-3.	Front Winch Cable Replacement	13-3
13-4.	Automatic Brake Test and Adjustment	13-4
13-5.	Front Winch Replacement	13-8
13-6.	Front Winch Propeller Shaft Replacement	13-12
13-7.	Winch Drum Lock Replacement (M756A2)	13-13
13-8.	Rear Winch Control Lever Linkage Maintenance (M764)	13-14
13-9.	Rear Winch Drum Clutch Lever and Guide Plate Replacement (M756A2)	13-16
13-10.	Rear Winch Cable Replacement (M764)	13-17
13-11.	Rear Winch Drivechain Maintenance (M756A2)	13-18
13-12.	Carriage Cross Chain Maintenance (M764)	13-20
13-13.	Rear Winch Cable Replacement (M756A2)	13-23
13-14.	First Reduction Drivechain Maintenance (M764)	13-24
13-15.	Second Reduction Drivechain Maintenance (M764)	13-26
13-16.	Rear Winch Oil Draintube Replacement (M764)	13-28
13-17.	Rear Winch Oil Draintubes Replacement (M756A2)	13-29
13-18.	Rear Winch Replacement (M756A2)	13-30

**13-2. FRONT WINCH DRAG BRAKE TEST AND ADJUSTMENT**

This task covers:

a. Testing

b. Adjustment

**INITIAL SETUP:**

APPLICABLE MODELS

All

EQUIPMENT CONDITION

Parking brake set (TM 9-2320-361-10).

REFERENCES (TM)

TM 9-2320-361-10

TM 9-2320-361-20P

GENERAL SAFETY INSTRUCTIONS

Wear leather gloves when handling winch cable.

WARNING

Wear leather gloves when handling cable. Do not let cable run through hands. Broken or rusty wires can cause injury to personnel.

**a. Testing**

1. Pull out drum lock lever (1) and turn 90° clockwise to unlocked position.
2. Pull winch cable (3) out three to four feet. Winch drum (2) should stop turning when cable (3) is released. If drum (2) does not stop turning, adjust drag brake.

**b. Adjustment**

NOTE

When performing step 1, adjusting screw is to be turned in 1/2 turn increments until proper drag adjustment is accomplished.

1. Turn adjusting screw (4) clockwise to increase drag.
2. Repeat drag test to make sure drag is adjusted correctly.

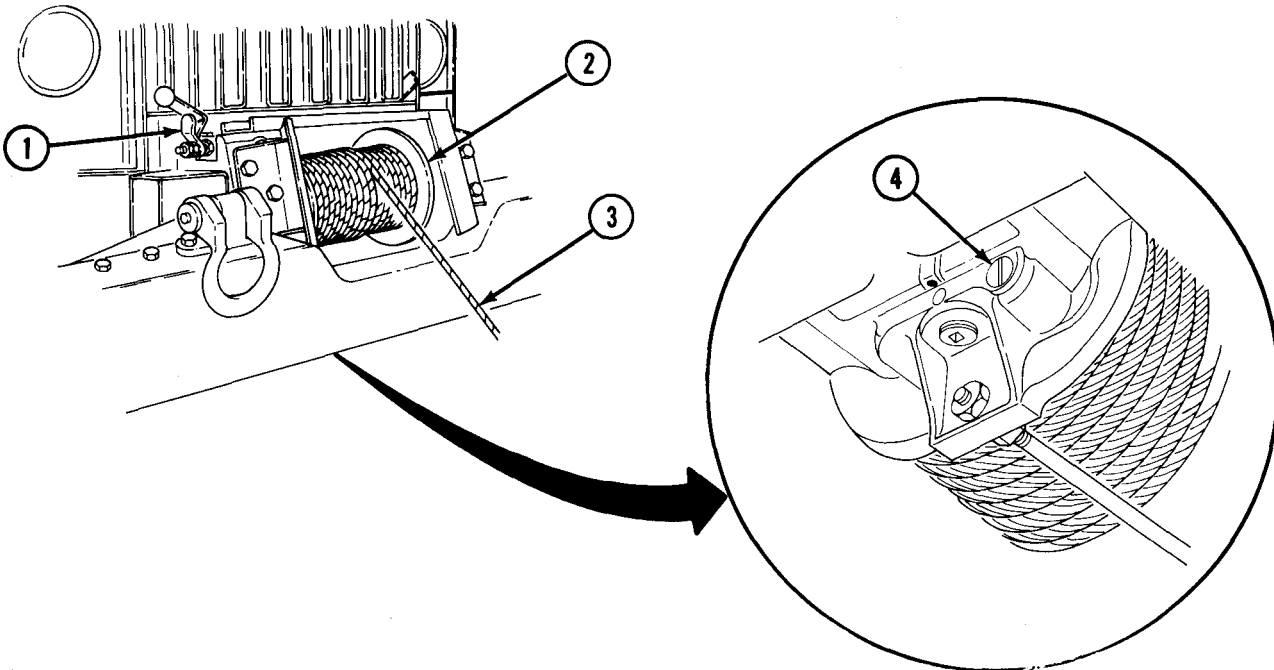

### 13-3. FRONT WINCH CABLE REPLACEMENT

This task covers:

a. Removal

b. Installation

#### INITIAL SETUP:

##### APPLICABLE MODELS

All

##### REFERENCES (TM)

LO 9-2320-209-12-1

TM 9-2320-361-10

TM 9-2320-361-20P

##### EQUIPMENT CONDITION

- Parking brake set (TM 9-2320-361-10).
- Front winch cable unwound (TM 9-2320-361-10).

##### GENERAL SAFETY INSTRUCTIONS

Wear leather gloves when handling winch cable.

#### WARNING

Wear leather gloves when handling cable. Do not let cable run through hands. Broken or rusty wires can cause injury to personnel.

#### **a. Removal**

1. Loosen setscrew (2) and remove front winch cable (3) from drum (1).
2. Remove nut (4) and screw (6) from clevis (7) and remove chain (5).

#### **b. Installation**

1. Install chain (5) on clevis (7) with screw (6) and nut (4).
2. Install front winch cable (3) in drum (1) and tighten setscrew (2).

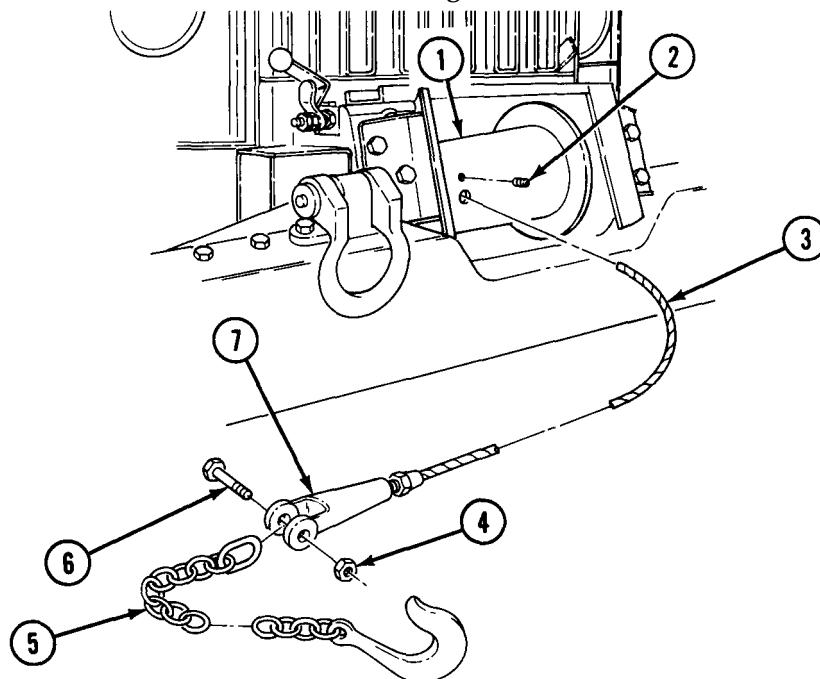

FOLLOW-ON TASKS: •Wind front winch cable on front winch drum (TM 9-2320-361-10).  
•Lubricate winch cable (LO 9-2320-209-12-1).



**13-4. AUTOMATIC BRAKE TEST AND ADJUSTMENT**

This task covers:

a. Testing

b. Adjustment

**INITIAL SETUP:**

APPLICABLE MODELS

All

PERSONNEL REQUIRED

Two

REFERENCES (TM)

TM 9-2320-361-10

EQUIPMENT CONDITION

Parking brake set (TM 9-2320-361-10).

GENERAL SAFETY INSTRUCTIONS

- Wear leather gloves when handling winch cable.
- Never stand between test vehicles during winching procedures.
- Assistant must remain in secondary vehicle.
- Use hand throttle to control engine speed when operating winch.

NOTE

Procedures for front winch and rear winch (M756A2) automatic brake adjustment are the same. This procedure covers the front winch testing and adjustment only.

**a. Testing**

1. Park test vehicle (1) at top of steep grade facing downhill and chock wheels (refer to TM 9-2320-361-10).
2. Park secondary vehicle (2) at bottom of steep grade facing test vehicle (1).

WARNING

- Wear leather gloves when handling cable. Do not let cable run through hands. Broken or rusty wires can cause injury to personnel.
- Never stand between test vehicles. Assistant must remain in secondary vehicle to engage service brake if cable snaps or automatic brake fails. Failure to do this may result in injury to personnel.

CAUTION

Do not use front winch to pay out line loads greater than 3,000 lb (1,362 kg) for any distance greater than 10 ft (3.1 m). Damage to equipment may result.

3. Pull out drum lock lever (4) and turn 90° clockwise to unlocked position. Unwind cable (5) and rig to secondary vehicle (2).
4. Place secondary vehicle's (2) transmission lever in neutral position. Disengage parking brake and disengage front wheel drive lever if engaged.

WARNING

Never stand between test vehicles. Assistant must remain in secondary vehicle to engage service brake if cable snaps or automatic brake fails. Failure to do this may result in injury to personnel.

CAUTION

Refer to TM 9-2320-361-10 for safe working loads.

5. Place winch drum clutch lever (3) in ENGAGE position.

13-4. AUTOMATIC BRAKE TEST AND ADJUSTMENT (Contd)

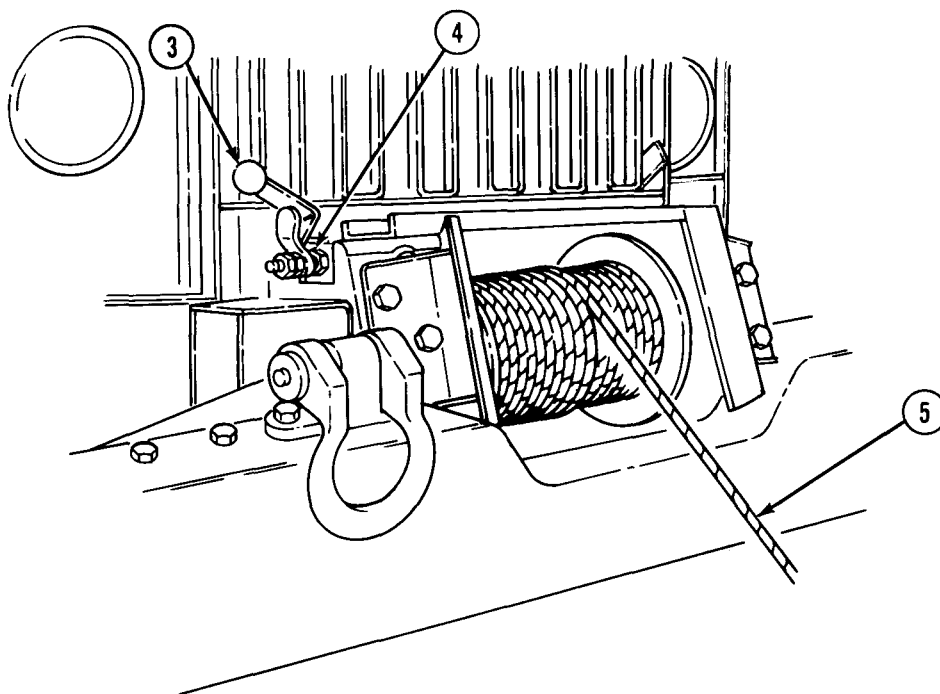
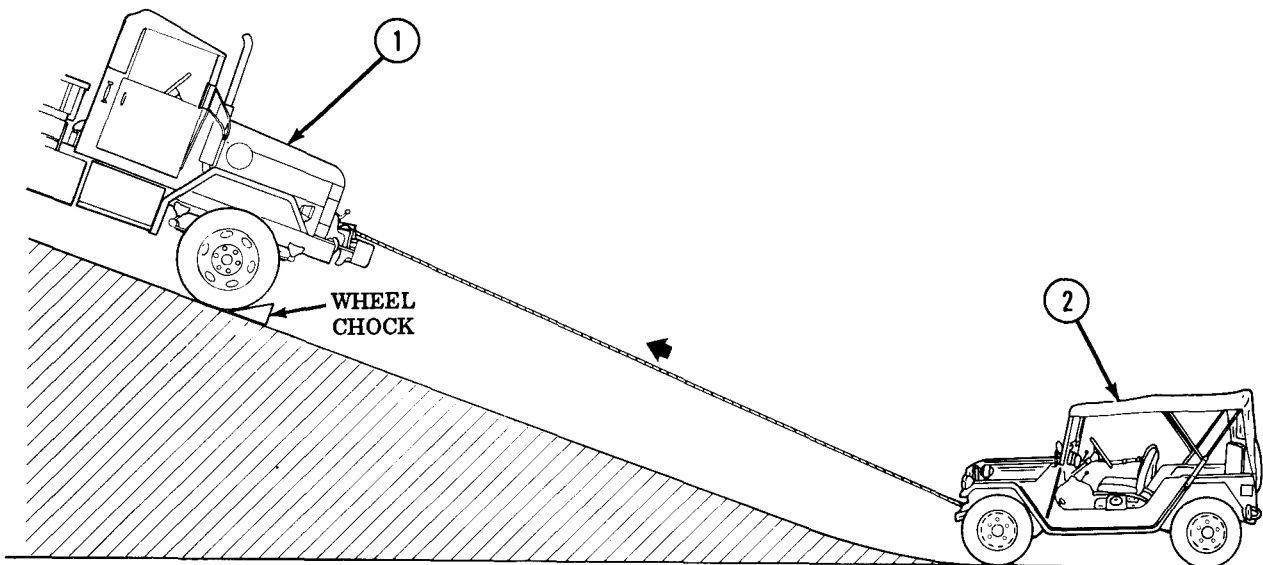

**13-4. AUTOMATIC BRAKE TEST AND ADJUSTMENT (Contd)**

- Place transfer case shift lever (5) to NEUTRAL position and transmission power takeoff lever (6) to LOW position on test vehicle (1).

**WARNING**

Always use hand throttle to control engine speed when operating winch. Avoid sudden changes in speed. Rough or jerky operation may cause broken shearpins and snapped cables. Injury to personnel or damage to equipment may result.

- Depress clutch pedal (3) and start vehicle (1). Place transmission gearshift lever (4) in 4th gear position.
- Release clutch pedal (3) slowly. Using hand throttle, pull secondary vehicle (2) halfway up grade. Depress clutch pedal (3). If secondary vehicle (2) rolls back down grade, adjust automatic brake.

**b. Adjustment**

- Disengage hand throttle. Depress clutch pedal (3) and place PTO lever (6) in REVERSE position. Release clutch pedal (3) and unwind secondary vehicle (2) back to level ground and set parking brake.
- Place PTO lever (6) in NEUTRAL position and disengage drum clutch lever (7).
- Adjust brake band by turning adjusting screw (9) in 1/2-turn clockwise increments to increase braking action.
- Repeat testing and adjustment until correct adjustment is obtained.

**NOTE**

Perform steps 5 through 7 only when new winch is installed.

- Pay out winch cable (8) for 5 minutes at engine idle (TM 9-2320-361-10).
- Allow brake band to cool for approximately 1-1/2 hours.
- Repeat brake band adjustment procedure.

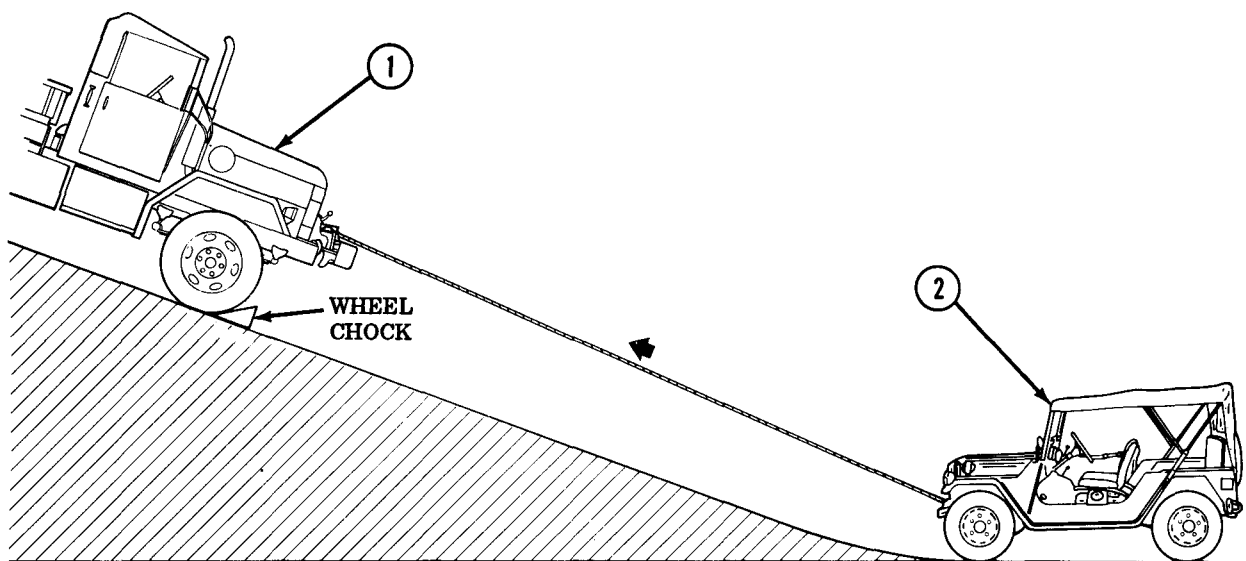

13-4. AUTOMATIC BRAKE TEST AND ADJUSTMENT (Contd)

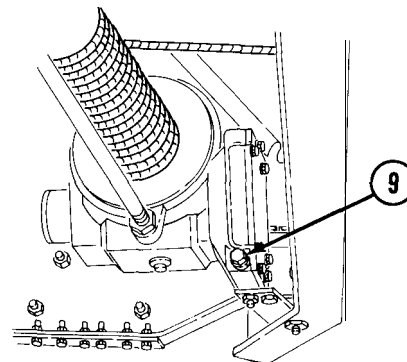
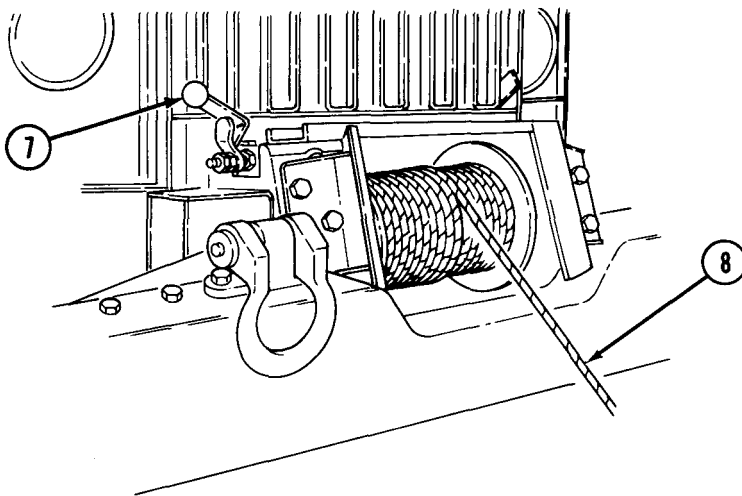
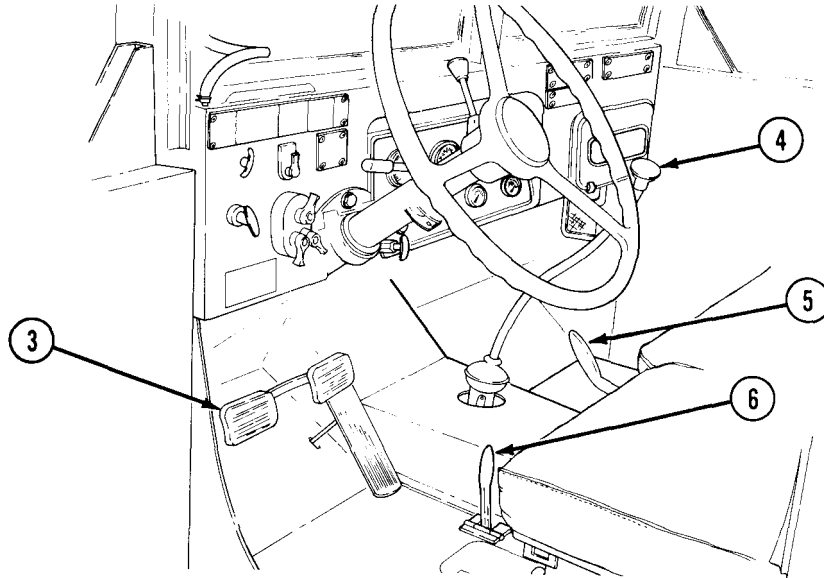

FOLLOW-ON TASK: Wind front winch cable on front winch drum (TM 9-2320-361-10).

## 13-5. FRONT WINCH REPLACEMENT

This task covers:

a. Removal

b. Installation

### INITIAL SETUP:

#### APPLICABLE MODELS

All

#### MATERIALS/PARTS

Ten locknuts  
Eighteen lockwashers

#### PERSONNEL REQUIRED

Two

#### REFERENCES (TM)

LO 9-2320-209-12-1  
TM 9-2320-361-10  
TM 9-2320-361-20P

#### EQUIPMENT CONDITION

- Parking brake set (TM 9-2320-361-10).
- Front winch propeller shaft removed (para. 13-6).
- Front winch cable removed (para. 13-3).
- Front bumper removed (para. 10-9).
- Brush guard removed (para. 10-8).
- Drain oil from winch (LO 9-2320-209-12-1).

#### GENERAL SAFETY INSTRUCTIONS

Personnel must stand clear during lifting operations.

### a. Removal

#### WARNING

All personnel must stand clear of winch during lifting operations. A swinging or shifting load may result in injury to personnel.

#### NOTE

Perform step 1 only if front winch requires repair.

1. Remove four locknuts (7), screws (3), two washers (5) and brush guard brackets (4) from frame rail (6). Discard locknuts (7).
2. Secure chain sling (1) to front winch (11) and lifting device (2). Raise lifting device (2) enough to remove slack from chain sling (1).

#### NOTE

Assistant will help with step 3.

3. Remove six locknuts (9), screws (10), and front winch (11) from frame extensions (8). Discard locknuts (9).
4. Lower front winch (11) approximately 1 in. (2.5 cm) from ground and remove twelve screws (15), lockwashers (16), washers (17), and two winch supports (18) from front winch (11). Discard lockwashers (16).
5. Lower front winch (11) to ground and remove chain sling (1) from lifting device (2) and front winch (11).
6. Remove six screws (20), lockwashers (19), and two cable guards (21) from front winch (11). Discard lockwashers (19).
7. Install twelve washers (17), new lockwashers (16), and screws (15) in front winch (11). Hand tighten screws (15).

### b. Installation

#### NOTE

Perform steps 1 and 2 if installing new or repaired front winch.

1. Rotate winch drum (14) on front winch (11) one complete revolution to ensure front winch (11) moves freely without binding. Replace or repair front winch (11) if winch drive (14) binds.
2. Operate drum clutch lever (13) and drum lock lever (12) to ensure both operate correctly. Replace or repair front winch (11) if levers (12) or (13) do not operate correctly.

**13-5. FRONT WINCH REPLACEMENT (Contd)**

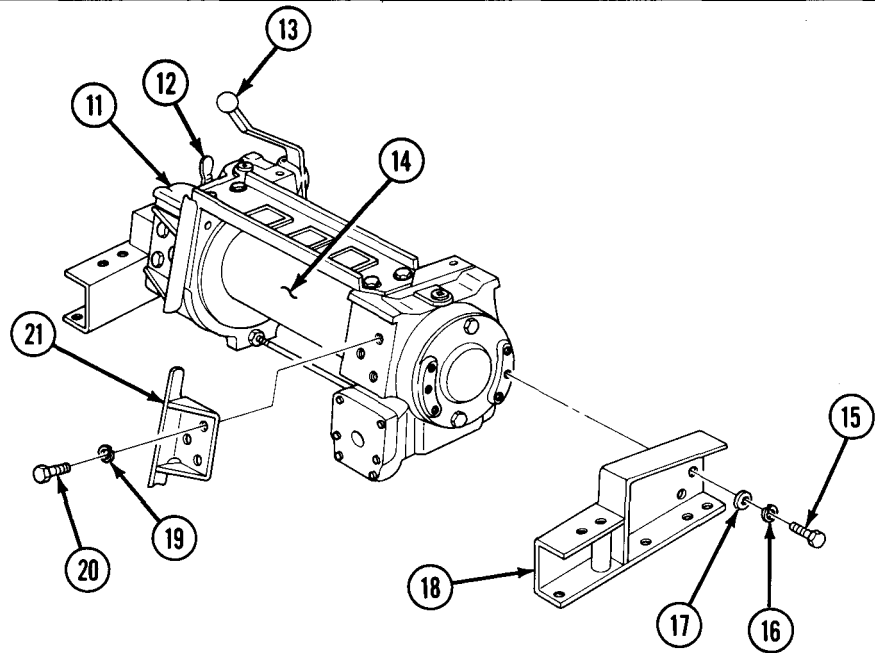
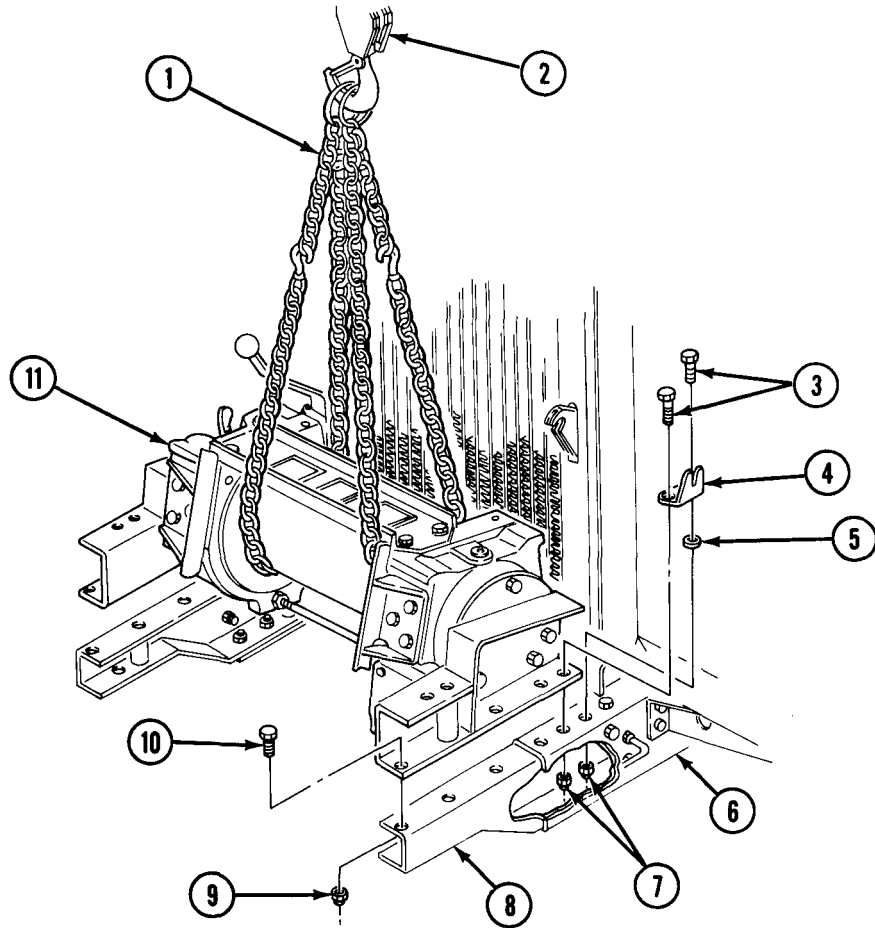

**13-5. FRONT WINCH REPLACEMENT (Contd)**

3. Install two cable guards (8) on front winch (1) with six new lockwashers (6) and screws (7).
4. Remove twelve screws (2), lockwashers (3), and washers (4) from new front winch (1). Discard lockwashers (3).
5. Secure chain sling (9) around front winch (1) and lifting device (10). Raise front winch (1) approximately 1 in. (2.5 cm) off ground.
6. Install two winch supports (5) on front winch (1) with twelve washers (4), new lockwashers (3), and screws (2).

NOTE

Assistant will help with step 7.

7. Install front winch (1) and two winch supports (5) on two frame extensions (16) with six screws (18) and new locknuts (17).
8. Install two brush guard brackets (12) and washers (13) to frame rail (14) with four screws (11) and new locknuts (15).

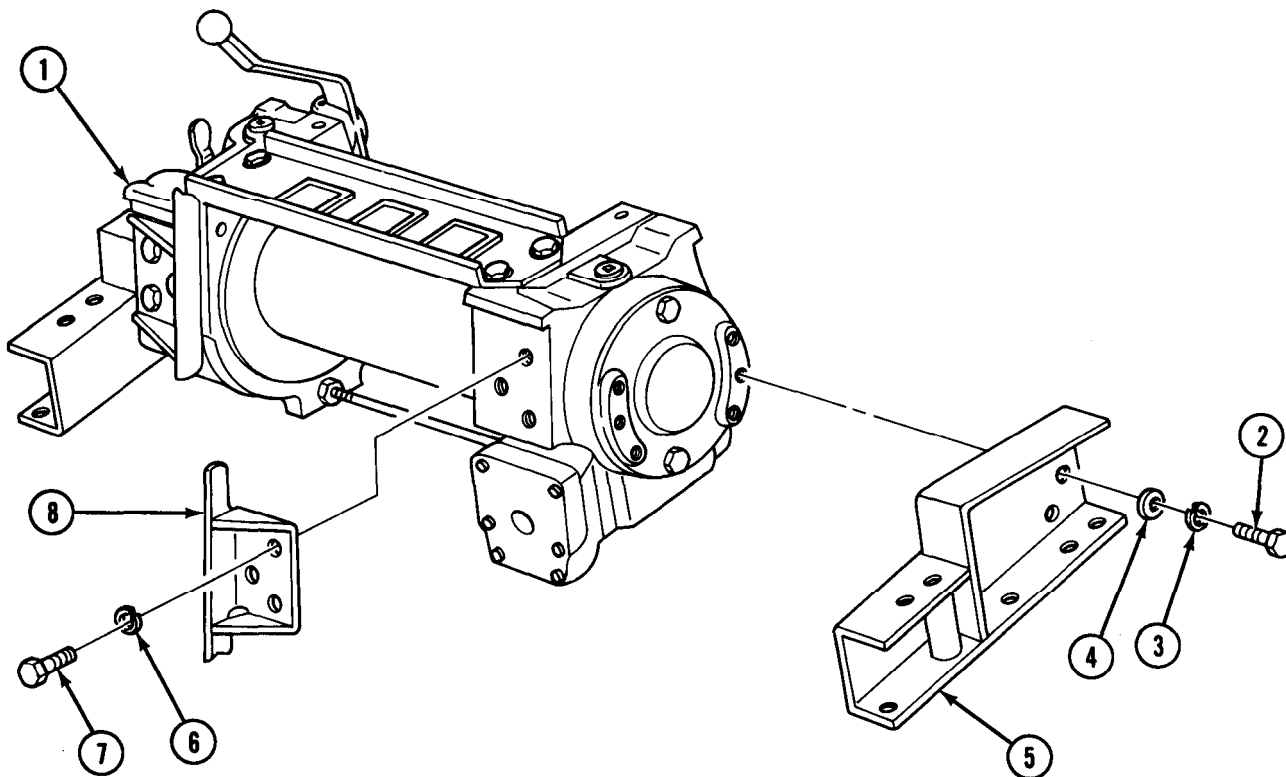

### 13-5. FRONT WINCH REPLACEMENT (Contd)

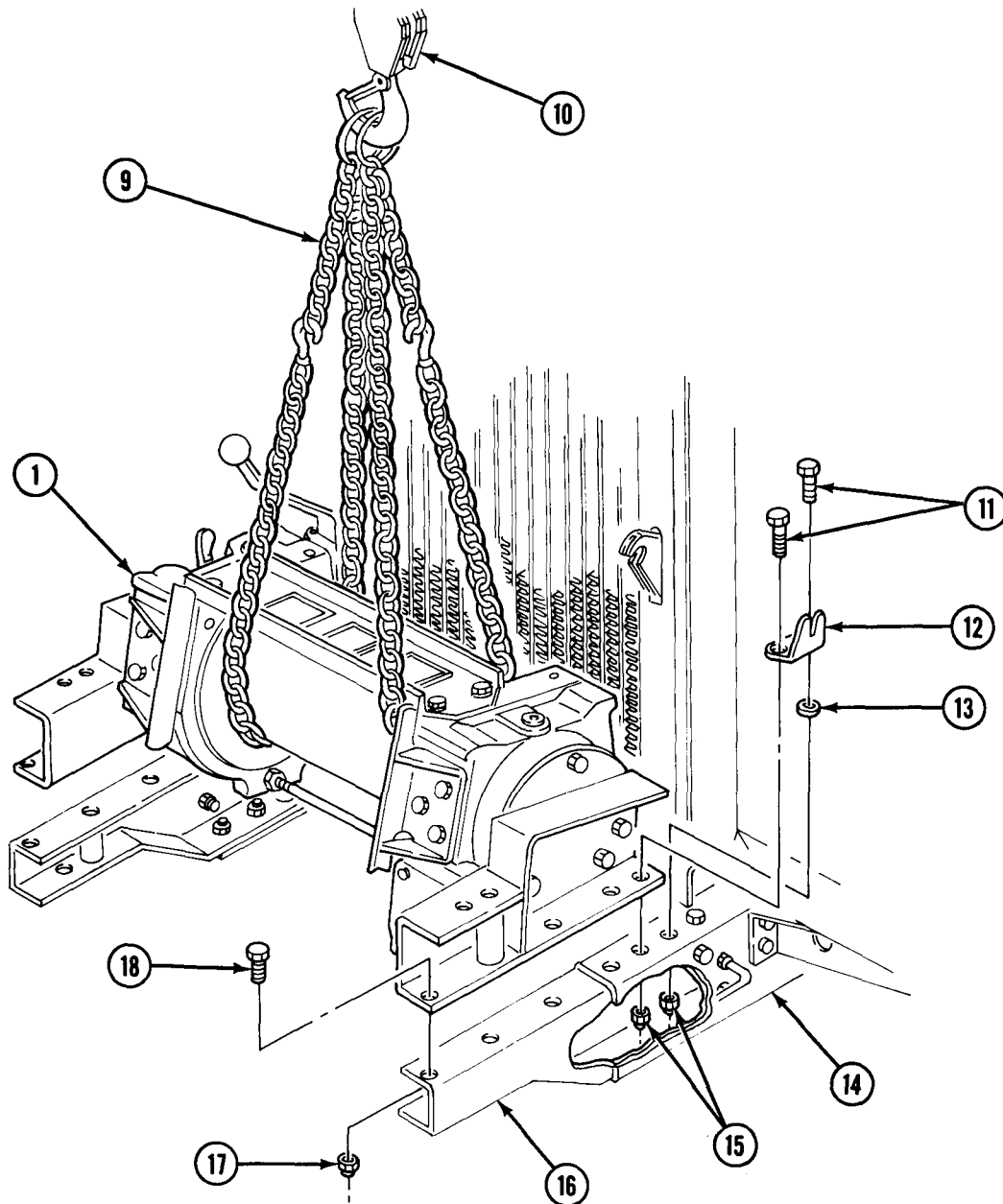

- FOLLOW-ON TASKS:
- Install front winch propeller shaft (para. 13-6).
  - Install brush guard (para. 10-8).
  - Install front winch cable (para. 13-3).
  - Install front bumper (para. 10-9).
  - Fill winch to proper oil level (LO 9-2320-209-12-1).
  - Adjust automatic brake (para. 13-4).



## 13-6. FRONT WINCH PROPELLER SHAFT REPLACEMENT

This task covers:

- |   |   |
|---|---|
| <ul style="list-style-type: none"> <li>a. Removal</li> <li>b. Inspection</li> </ul> | <ul style="list-style-type: none"> <li>c. Installation</li> </ul> |
|---|---|

**INITIAL SETUP:**

APPLICABLE MODELS

All

MATERIALS/PARTS

Two cotter pins  
 Four locknuts  
 GAA grease (Appendix C, Item 13)

REFERENCES (TM)

LO 9-2320-209-12-1  
 TM 9-2320-361-10  
 TM 9-2320-361-20P

EQUIPMENT CONDITION

Parking brake set (TM 9-2320-361-10).

**a. Removal**

NOTE

Place front winch control lever in LOW position to remove screws, then in NEUTRAL position to gain access to remaining screws.

1. Remove four screws (3), locknuts (1), and rear flange (11) from transmission power takeoff flange (2). Discard locknuts (1).
2. Remove two cotter pins (6), pin (5), propeller shaft (4), and yoke (8) from front winch shaft (7).
3. Slide rear yoke (10) off propeller shaft (4).

**b. Inspection**

Inspect two universal joints (9) for looseness or roughness. If damaged, replace (para. 7-4).

**c. Installation**

1. Place a light coat of GAA grease on propeller shaft (4) splines and install rear yoke (10) and rear flange (11) on propeller shaft (4).
2. Install front yoke (8) and propeller shaft (4) on front winch shaft (7) and align pin (5) hole with front winch shaft (7) hole. Install pin (5) through front yoke (8) and winch shaft (7) and secure with two new cotter pins (6).
3. Install rear yoke (10) and rear flange (11) to transmission PTO flange (2) with four screws (3) and new locknuts (1).

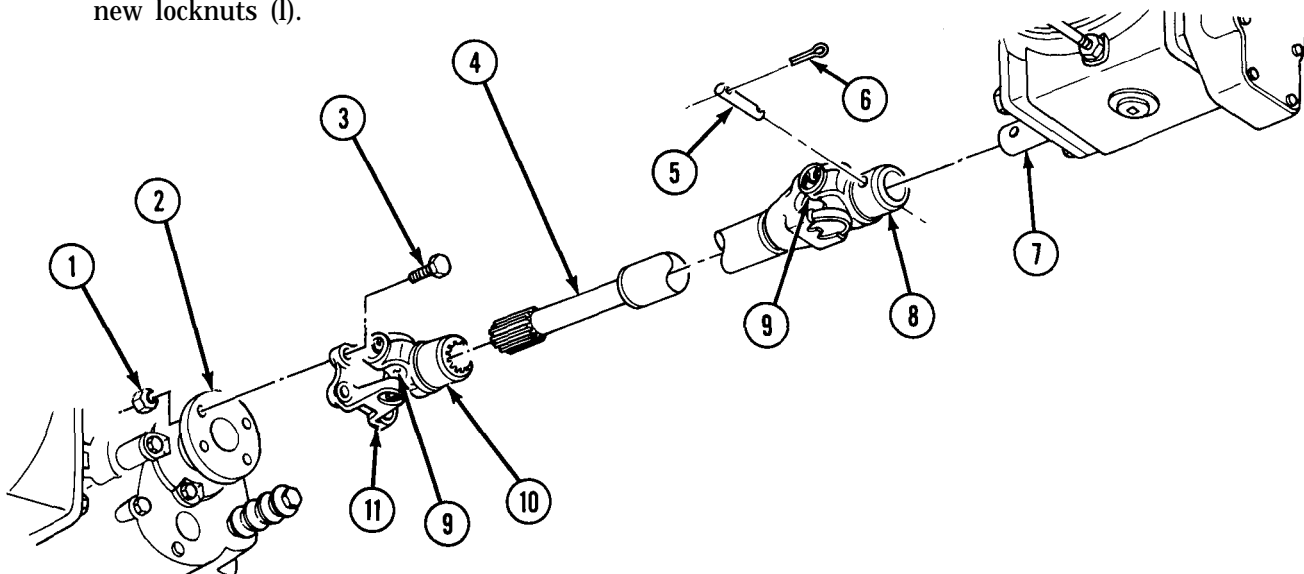

FOLLOW-ON TASK: Lubricate front winch propeller shaft (LO 9-2320-209-12-1).

## 13-7. WINCH DRUM LOCK REPLACEMENT (M756A2)

This task covers:

- a. Removal
- b. Inspection
- c. Installation

### INITIAL SETUP:

#### APPLICABLE MODELS

M756A2

#### MATERIALS/PARTS

Lubricating oil OE/HDO 30  
(Appendix C, Item 18)  
Drycleaning solvent (Appendix C, Item 26)

#### REFERENCES (TM)

TM 9-2320-361-10  
TM 9-2320-361-20P

#### EQUIPMENT CONDITION

Parking brake set (TM 9-2320-361-10).

#### GENERAL SAFETY INSTRUCTIONS

Have fire extinguisher nearby when using drycleaning solvent.

### a. Removal

1. Remove jamnut (3), nut (4), and drum lock latch (5) from poppet (1).
2. Remove poppet nut (6), spacer (7), spring (8), and poppet (1) from winch (2).

### b. Inspection

#### WARNING

Drycleaning solvent is flammable and will not be used near open flame. Use only in well-ventilated places. Failure to do so may result in injury to personnel.

1. Clean all parts in drycleaning solvent.
2. Inspect all parts for cracks, breaks, or scoring. If parts are damaged, replace.
3. Apply light coat of lubricating oil to poppet (1).

### c. Installation

1. Install poppet (1), spring (8), spacer (7), and poppet nut (6) in winch (2).
2. Install latch (5) on poppet (1) with nut (4) and jamnut (3).

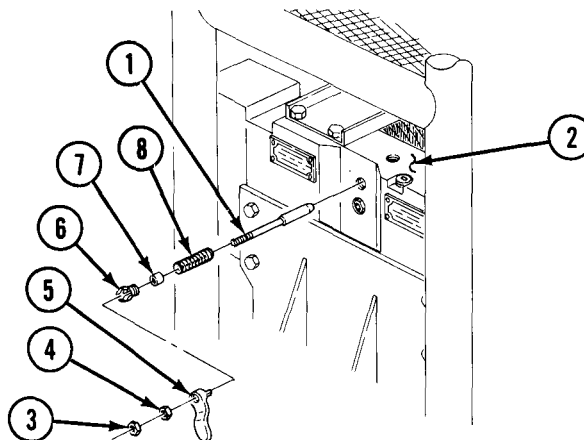

**13-8. REAR WINCH CONTROL LEVER LINKAGE MAINTENANCE (M764)**

This task covers:

a. Removal

b. Installation

**INITIAL SETUP:**

APPLICABLE MODELS

M764

MATERIALS/PARTS

Four cotter pins  
Locknut

REFERENCES (TM)

TM 9-2320-361-10  
TM 9-2320-361-20P

EQUIPMENT CONDITION

Parking brake set (TM 9-2320-361-10).

**a. Removal**

1. Remove cotter pin (19) and clevis pin (16) from control lever (17) and winch control rod (14). Discard cotter pin (19).
2. Remove locknut (20), screw (15), and winch control lever (17) from bracket (18). Discard locknut (20).
3. Remove cotter pin (4), clevis pin (7), and rod (14) from pivot bar (5). Discard cotter pin (4).
4. Remove two cotter pins (22) and (3), clevis pins (21) and (6), and winch control clevis (2) from lever (1) and pivot bar (5). Discard cotter pins (22) and (3).
5. Remove jamnut (9), nut (8), washer (10), screw (13), washer (12), and pivot bar (5) from bracket (11).

**b. Installation**

**NOTE**

After nut has been tightened in step 1, ensure pivot bar moves freely.

1. Install pivot bar (5) on bracket (11) with washer (12), screw (13), washer (10), nut (8), and jamnut (9).
2. Connect clevis (2) to lever (1) and pivot bar (5) with two clevis pins (6) and (21) and new cotter pins (3) and (22).
3. Adjust rod (14) to measure 58.13 in. (148 cm) from center of clevis (23) pin hole and center of clevis (24) pin hole.
4. Install rod (14) to pivot bar (5) with clevis pin (7) and new cotter pin (4).

**NOTE**

After locknut has been tightened in step 5, ensure control lever moves freely.

5. Install winch control lever (17) on bracket (18) with screw (15) and new locknut (20).
6. Connect winch control rod (14) to control lever (17) with clevis pin (16) and new cotter pin (19).

**13-8. REAR WINCH CONTROL LEVER LINKAGE MAINTENANCE (M764) (Contd)**

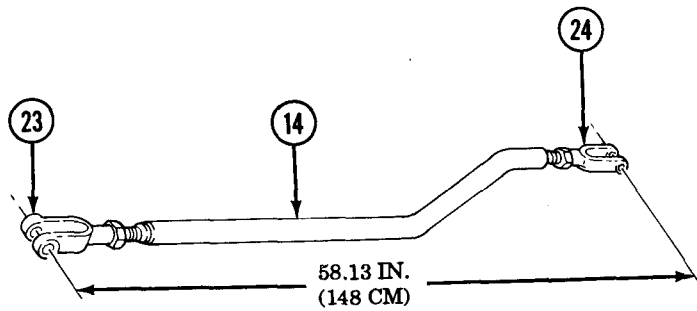
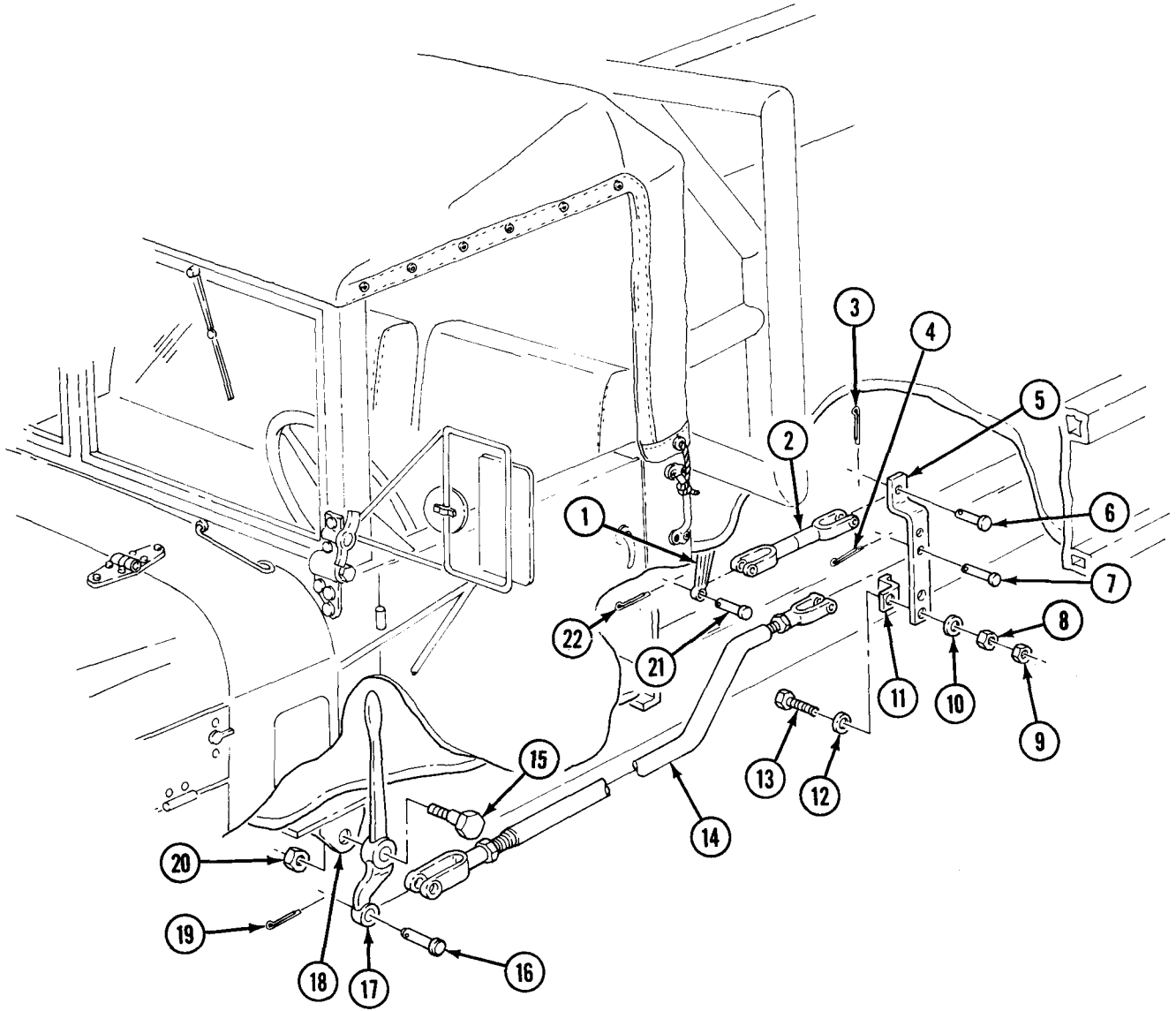

**13-9. REAR WINCH DRUM CLUTCH LEVER AND GUIDE PLATE REPLACEMENT (M756A2)**

This task covers:

a. Removal

b. Installation

**INITIAL SETUP:**

**APPLICABLE MODELS**

M756A2

**REFERENCES (TM)**

TM 9-2320-361-10

TM 9-2320-361-20P

**MATERIALS/PARTS**

Two lockwashers

Two grooved pins

**EQUIPMENT CONDITION**

Parking brake set (TM 9-2320-361-10).

**a. Removal**

1. Remove two screws (3), lockwashers (4), washers (5), data plate (6), and guide plate (7) from cab protector (2). Discard lockwashers (4).
2. Remove pin (8) and clutch lever (1) from winch shaft (9). Discard pin (8).
3. Remove pin (10), spring guide (11), center post (12), and two springs (13) from clutch lever (1). Discard pin (10).

**b. Installation**

1. Install spring guide (11), spring (13), center post (12), spring (13), and new pin (10) in clutch lever (1).
2. Install clutch lever (1) on winch shaft (9) with new pin (8).
3. Install guide plate (7) and data plate (6) on cab protector (2) with two washers (5), new lockwashers (4), and screws (3).

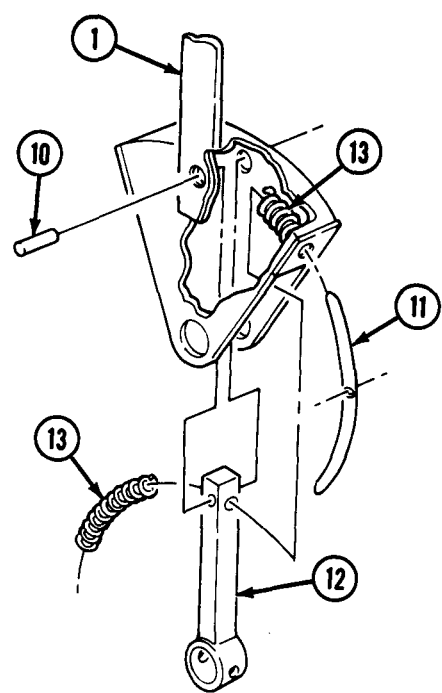
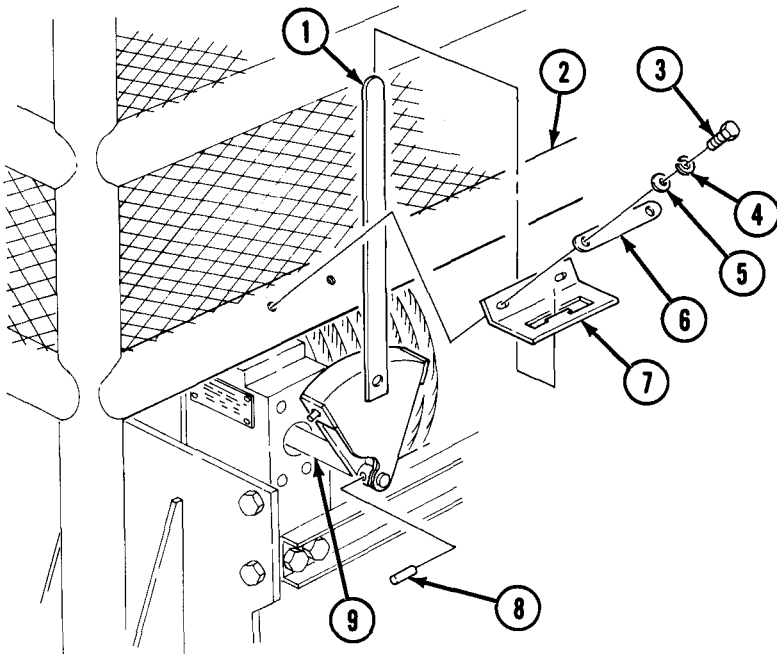

## 13-10. REAR WINCH CABLE REPLACEMENT (M764)

This task covers:

- a. Removal
- b. Inspection
- c. Installation

### INITIAL SETUP:

#### APPLICABLE MODELS

M764

#### REFERENCES (TM)

TM 9-2320-361-10

TM 9-2320-361-20P

#### EQUIPMENT CONDITION

- Parking brake set (TM 9-2320-361-10).
- Rear winch cable unwound (TM 9-2320-361-10).

#### GENERAL SAFETY INSTRUCTIONS

Wear leather gloves when handling rear winch cable.

### WARNING

Wear leather gloves when handling cable. Do not let cable run through hands. Broken or rusty wires can result in injury to personnel.

#### **a. Removal**

Remove screw (2), clamp (3), and winch cable (5) from drum (1) and pull winch cable (5) out through level wind (4).

#### **b. Inspection**

Inspect winch cable (5) for damage; replace if damaged.

#### **c. Installation**

Install cable (5) through level wind (4) onto drum (1) with clamp (3) and screw (2).

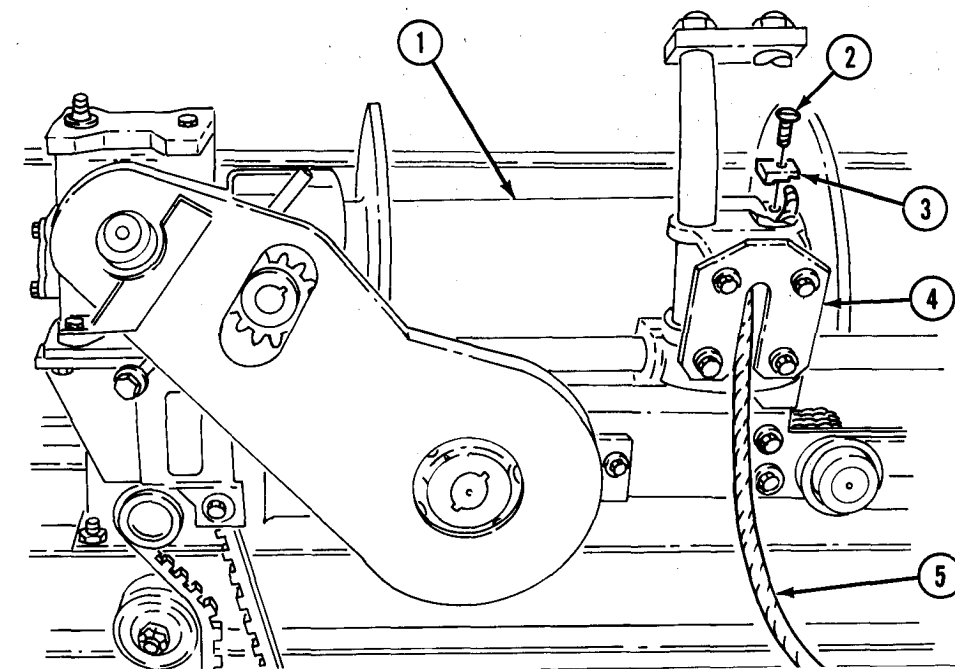

FOLLOW-ON TASK: Wind winch cable (TM 9-2320-361-10).

**13-11. REAR WINCH DRIVECHAIN MAINTENANCE (M756A2)**

This task covers:

- a. Removal
- b. Installation
- c. Adjustment

**INITIAL SETUP:**

APPLICABLE MODELS

M756A2

MATERIALS/PARTS

Two cotter pins  
Eighteen locknuts

PERSONNEL REQUIRED

Two

REFERENCES (TM)

TM 9-2320-361-10  
TM 9-2320-361-20P

EQUIPMENT CONDITION

- Parking brake set (TM 9-2320-361-10).
- Spare tire removed (TM 9-2320-361-10).

**a. Removal**

**NOTE**

Rotate power takeoff sprocket to gain access to master link.

Remove two cotter pins (2), master link keeper (3), master link (5), and drivechain (1) from rear winch sprocket (7) and power takeoff sprocket (6).

**b. Installation**

1. Install drivechain (1) around rear winch sprocket (7) and power takeoff sprocket (6). If drivechain ends will not meet, perform adjustment.
2. Install master link (5) and master link keeper (3) on drivechain (1) with two new cotter pins (2).
3. Measure drivechain (1) at midpoint (4) of drivechain (1) for 0.5 in. (1.3 cm) freeplay. If freeplay is not correct, adjust drivechain (1).

**c. Adjustment**

1. Remove four screws (9), washers (10), locknuts (15), and step (8) from step bracket (16) and toolbox (17). Discard locknuts (15).
2. Remove six locknuts (14) and washers (13) from screws (12). Discard locknuts (14).
3. Remove eight locknuts (20) and washers (19) from screws (18). Discard locknuts (20).

**NOTE**

Assistant will help with step 4.

4. Push cab protector (11) to obtain 0.5 in. (1.3 cm) freeplay at midpoint (4) of drivechain (1).
5. Install eight washers (19) and new locknuts (20) on screws (18).
6. Install six washers (13) and new locknuts (14) on screws (12).
7. Install step (8), four washers (10), screws (9), and new locknuts (15) to step bracket (16) and toolbox (17).

**13-11. REAR WINCH DRIVECHAIN MAINTENANCE (M756A2) (Contd)**

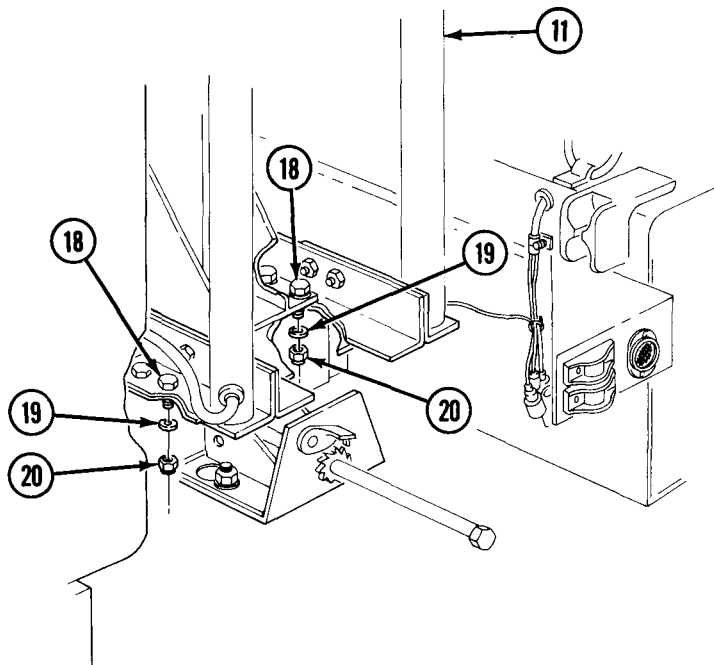
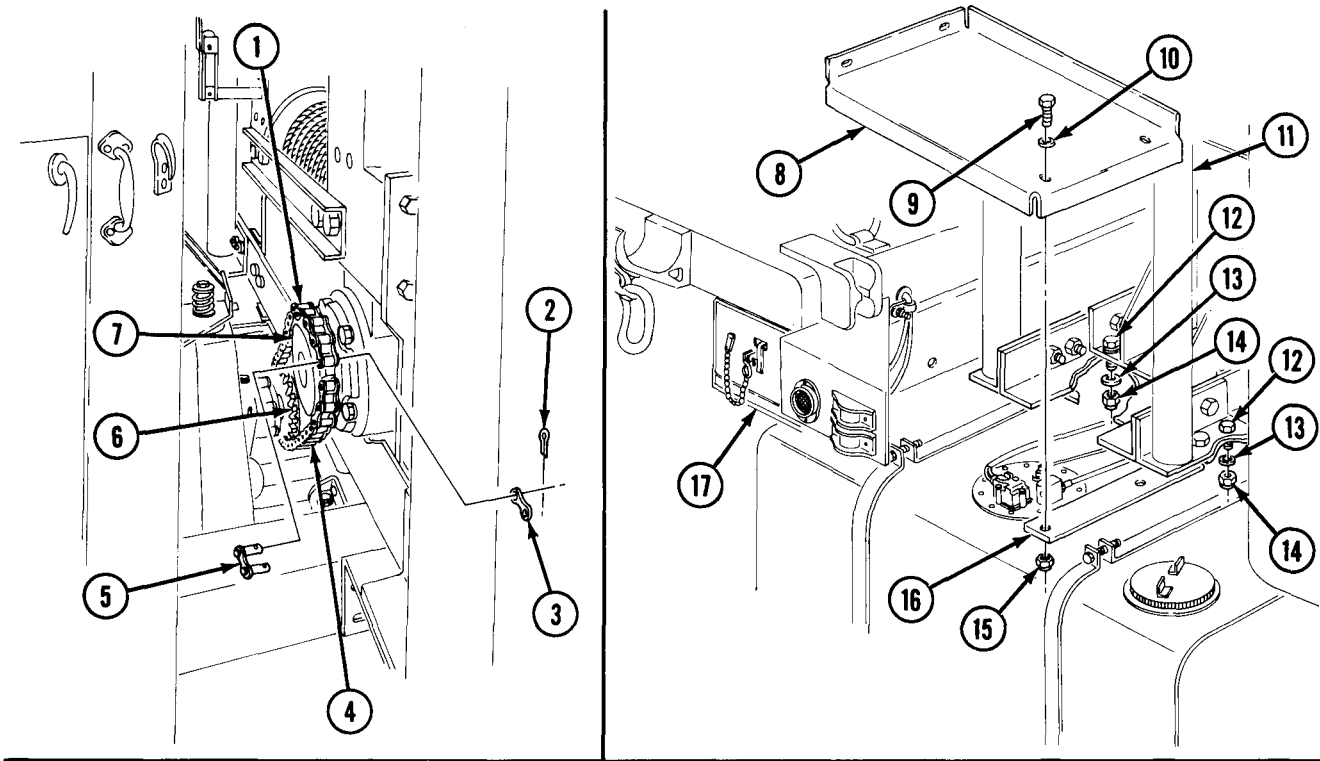

**FOLLOW-ON TASK** Install spare tire (TM 9-2320-361-10).



**13-12. CARRIAGE CROSS CHAIN MAINTENANCE (M764)**

This task covers

- |               |                 |
|---------------|-----------------|
| a. Removal    | c. Installation |
| b. Inspection | d. Adjustment   |

**INITIAL SETUP:**

**APPLICABLE MODELS**

M764

**MATERIALS/PARTS**

Four lockwashers  
Three clips

**REFERENCES (TM)**

TM 9-2320-361-10  
TM 9-2320-361-20P

**EQUIPMENT CONDITION**

- Parking brake set (TM 9-2320-361-10).
- Second reduction drivechain removed (para. 13-15).

**a. Removal**

1. Remove four screws (5), lockwashers (4), washers (3), and cross chain cover (2) from two cross brackets (1). Discard lockwashers (3).
2. Turn carriage drive sprocket (11) until connecting link (16) is accessible.
3. Remove clip (12), keeper (13), two spacers (14), connecting link (16), and cross chain (15) from sprockets (19) and (20). Discard clips (12).

**NOTE**

Perform step 4 if tensioner is damaged.

4. Remove two clips (6), pins (7), chain guide (8), setscrew (9), and chain guide pin (10) from cross chain (15). Discard clips (6).

**b. Inspection**

Check cross chain (15), chain guide (8), and sprockets (19) and (20) for cracks, bends, or breaks. If damaged, replace.

**c. Installation**

1. Install chain guide pin (10) and setscrew (9) on chain guide (8). Install chain guide (8), two pins (7), and new clips (6) on cross chain (15).
2. Install cross chain (15) on two sprockets (19) and (20) with connecting link (16), two spacers (14), keeper (13), and new clip (12).
3. Install cross chain cover (2) to two cross chain brackets (1) with four washers (3), new lockwashers (4), and screws (5).

**NOTE**

Perform step 1 if cross chain cover has not been removed.

1. Remove four screws (5), lockwashers (4), washers (3), and cross chain cover (2) from two cross chain brackets (1). Discard lockwashers (4).
2. Measure distance (18) from center of sprocket (19) and inner edge of drum flange (17). Repeat for opposite side. Measurement must be equal.

**13-12. CARRIAGE CROSS CHAIN MAINTENANCE (M764) (Contd)**

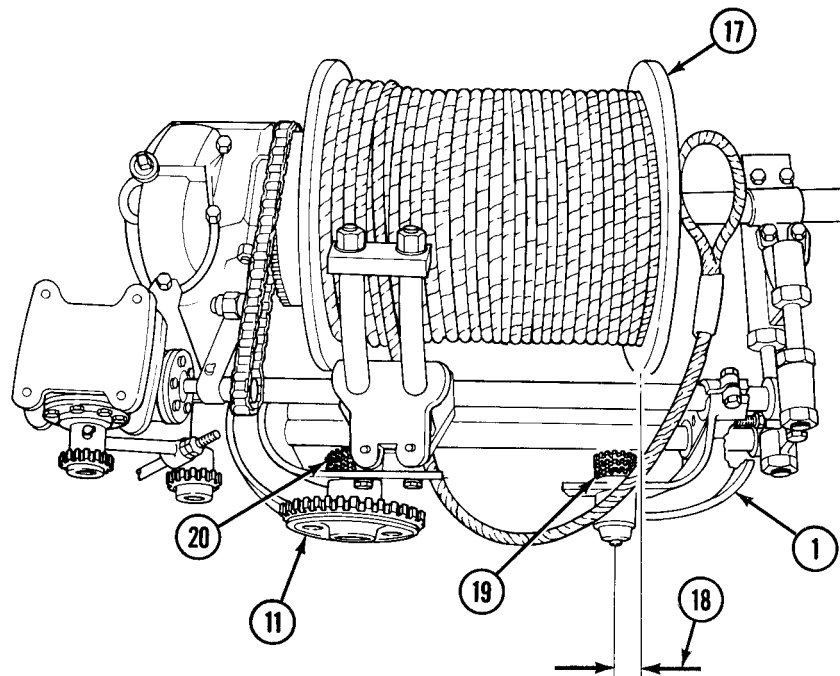
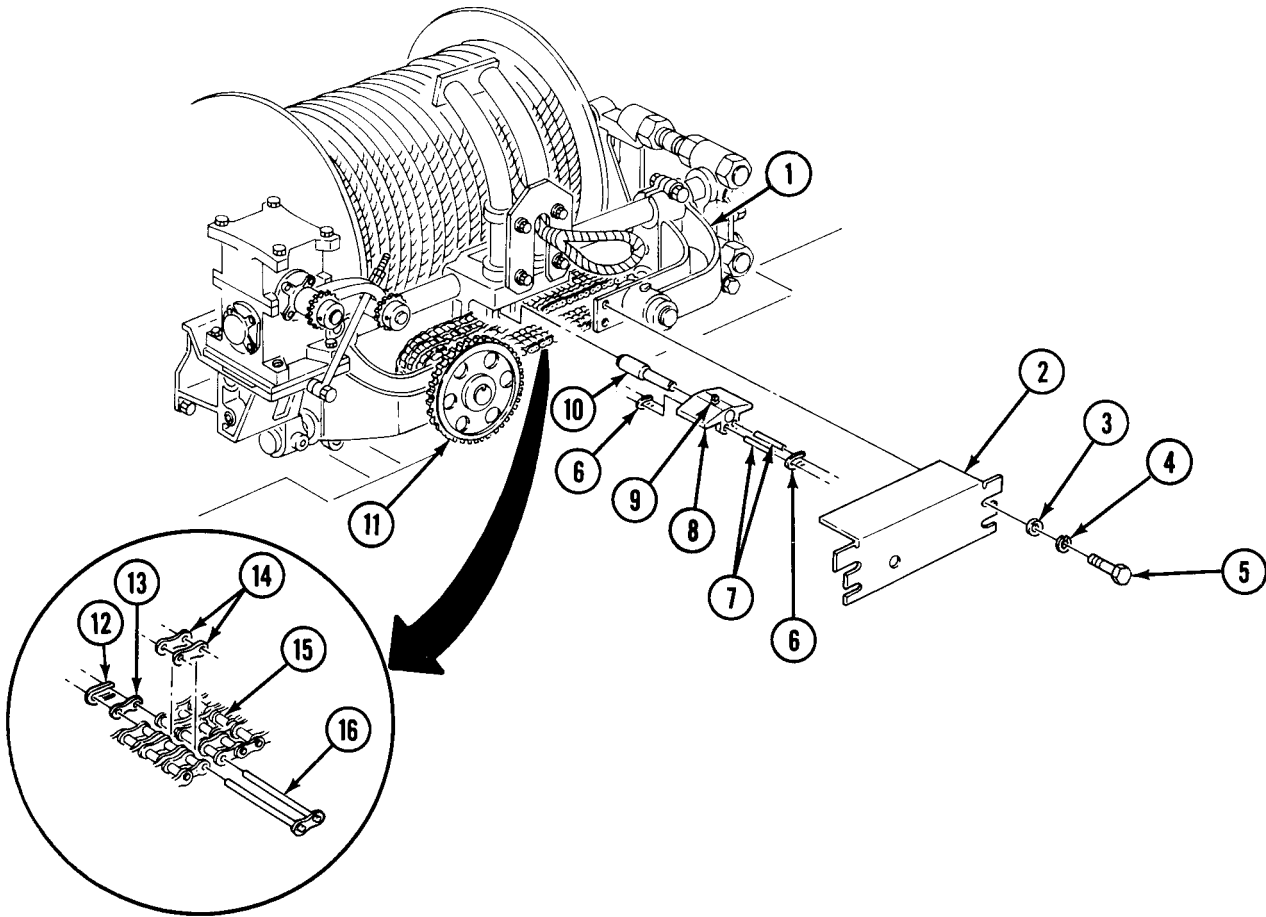

**13-12. CARRIAGE CROSS CHAIN MAINTENANCE (M764) (Contd)**

**NOTE**

If distances are not equal, perform step 3.

3. Loosen four cross chain bracket screws (2), nuts (1), two jamnuts (4), and adjusting screws (3). Adjust two adjusting screws (3).
4. Tighten two jamnuts (4). Ensure adjusting screws (3) do not turn. Tighten four cross chain bracket screws (2) and nuts (1).
5. Measure for 0.5 in. (1.3 cm) freeplay at cross chain midpoint (10). If freeplay is incorrect, adjust cross chain (11).
6. Loosen two jamnuts (4) and measure 0.5 in. (1.3 cm) freeplay at cross chain midpoint (10). Adjust screws (3) until 0.5 in. (1.3 cm) free play is obtained.
7. Tighten two jamnuts (4). Ensure adjusting screws (3) do not turn.
8. Install cross chain cover (6) to two cross chain brackets (5) with four washers (7), new lock-washers (8), and screws (9).

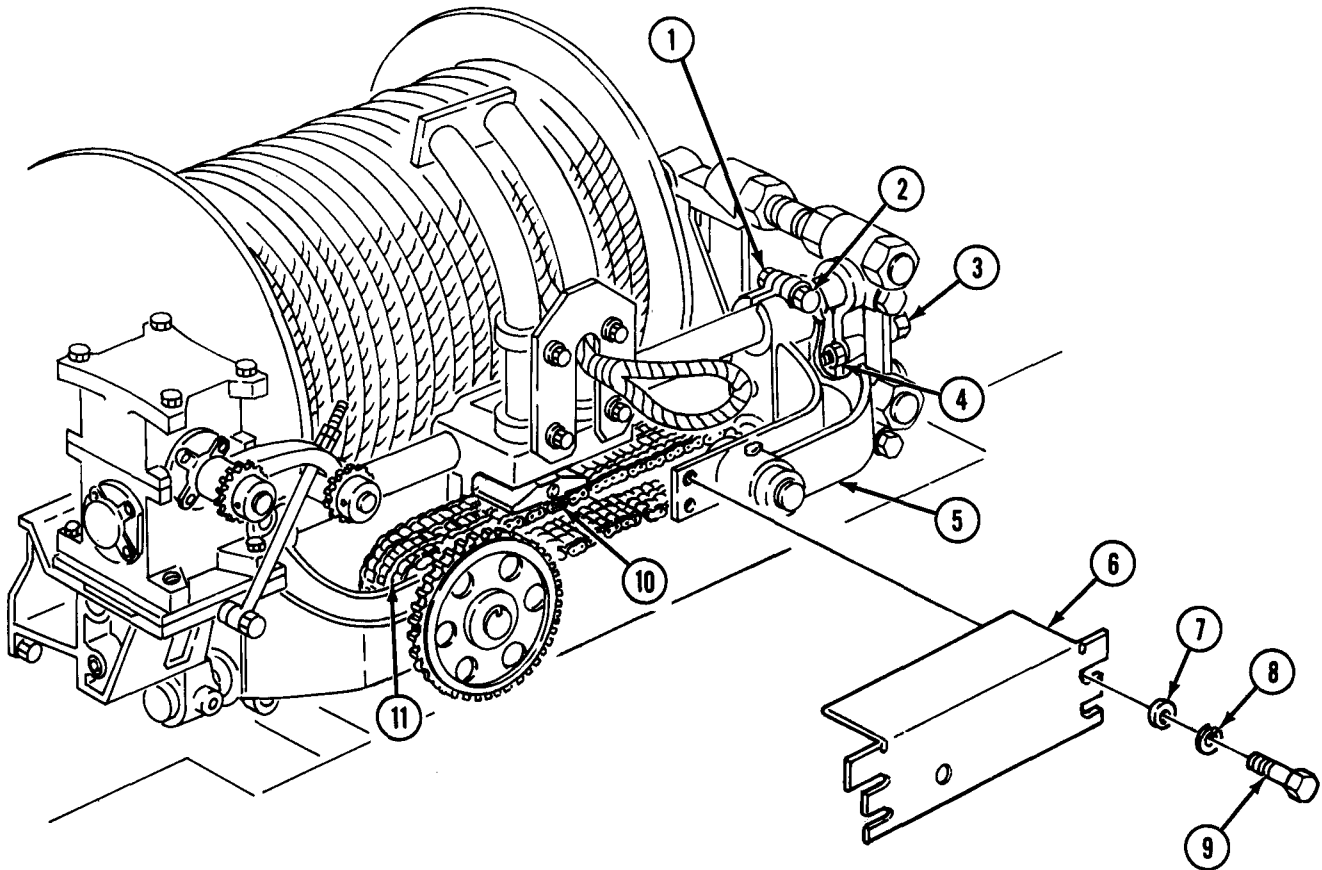

FOLLOW-ON TASK: Install second reduction drivechain (para. 13-15).

### 13-13. REAR WINCH CABLE REPLACEMENT (M756A2)

This task covers:

a. Removal

b. Installation

#### INITIAL SETUP:

##### APPLICABLE MODELS

M756A2

##### REFERENCES (TM)

TM 9-2320-361-10

TM 9-2320-361-20P

##### EQUIPMENT CONDITION

- Parking brake set (TM 9-2320-361-10).
- Rear winch cable unwound (TM 9-2320-361-10).

##### GENERAL SAFETY INSTRUCTIONS

Wear leather gloves when handling rear winch cable.

#### WARNING

Wear leather gloves when handling cable. Do not let cable run through hands. Broken or rusty wires can cause injury to personnel.

#### **a. Removal**

1. Loosen setscrew (2) and remove rear winch cable (3) from drum (1).
2. Remove nut (6) and screw (4) from clevis (5) and remove chain (7).

#### **b. Installation**

1. Install chain (7) on clevis (5) with screw (4) and nut (6).
2. Install rear winch cable (3) in drum (1) and tighten setscrew (2).

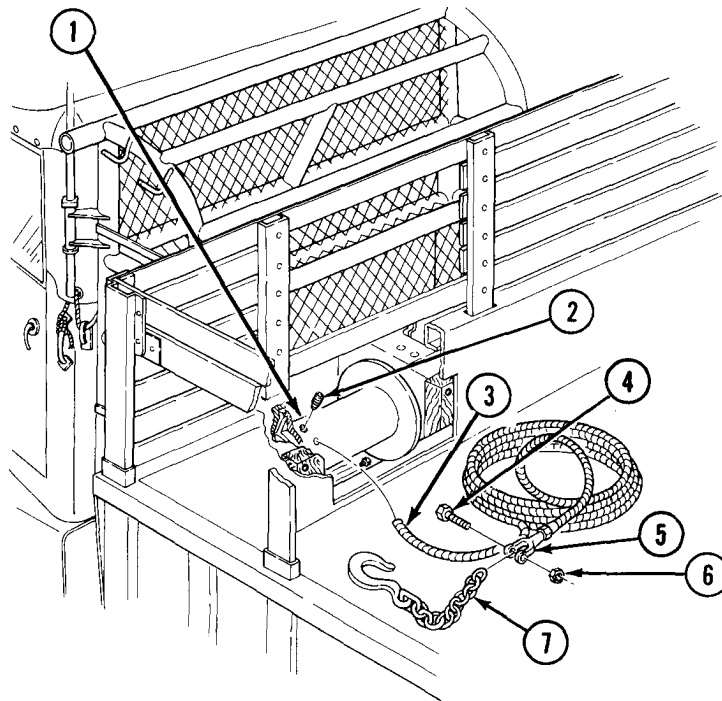

FOLLOW-ON TASK: Wind rear winch cable on rear winch drum (TM 9-2320-361-10).

**13-14. FIRST REDUCTION DRIVECHAIN MAINTENANCE (M764)**

This task covers:

- a. Removal
- b. Installation
- c. Adjustment

**INITIAL SETUP:**

APPLICABLE MODELS

M764

MATERIALS/PARTS

Clip

REFERENCES (TM)

TM 9-2320-361-10

TM 9-2320-361-20P

EQUIPMENT CONDITION

Parking brake set (TM 9-2320-361-10).

**a. Removal**

1. Remove two screws (4), washers (3), and drivechain cover (2) from speed reducer (1) and worm gear housing (10).
2. Remove clip (13), keeper (14), master link (15), and drivechain (6) from drum sprocket (7), idler sprocket (8), and input shaft sprocket (9). Discard clip (13).

1. Install drivechain (6) around idler sprocket (8), input shaft sprocket (9), and drum sprocket (7). If drivechain (6) ends do not meet, adjust drivechain (6).
2. Install master link (15) and keeper (14) on drivechain (6) with new clip (13).
3. Push down on drivechain (6) to measure freeplay at midpoint (5) of drivechain (6). Freeplay should measure 0.5 in. (1.3 cm). If not, adjust drivechain (6).

**c. Adjustment**

**NOTE**

Perform step 1 if reduction drivechain cover has not been removed.

1. Remove two screws (4), washers (3), and drivechain cover (2) from speed reducer (1) and worm gear housing (10).
2. Loosen jamnut (12) and adjust setscrew (11) until 0.5 in. (1.3 cm) freeplay is obtained at midpoint (5) of drivechain (6) while pushing down on drivechain (6).
3. Tighten jamnut (12) and ensure setscrew (11) does not move.
4. Install drivechain cover (2) to speed reducer (1) and worm gear housing (10) with two washers (3) and screws (4).

**13-14. FIRST REDUCTION DRIVECHAIN MAINTENANCE (M764) (Contd)**

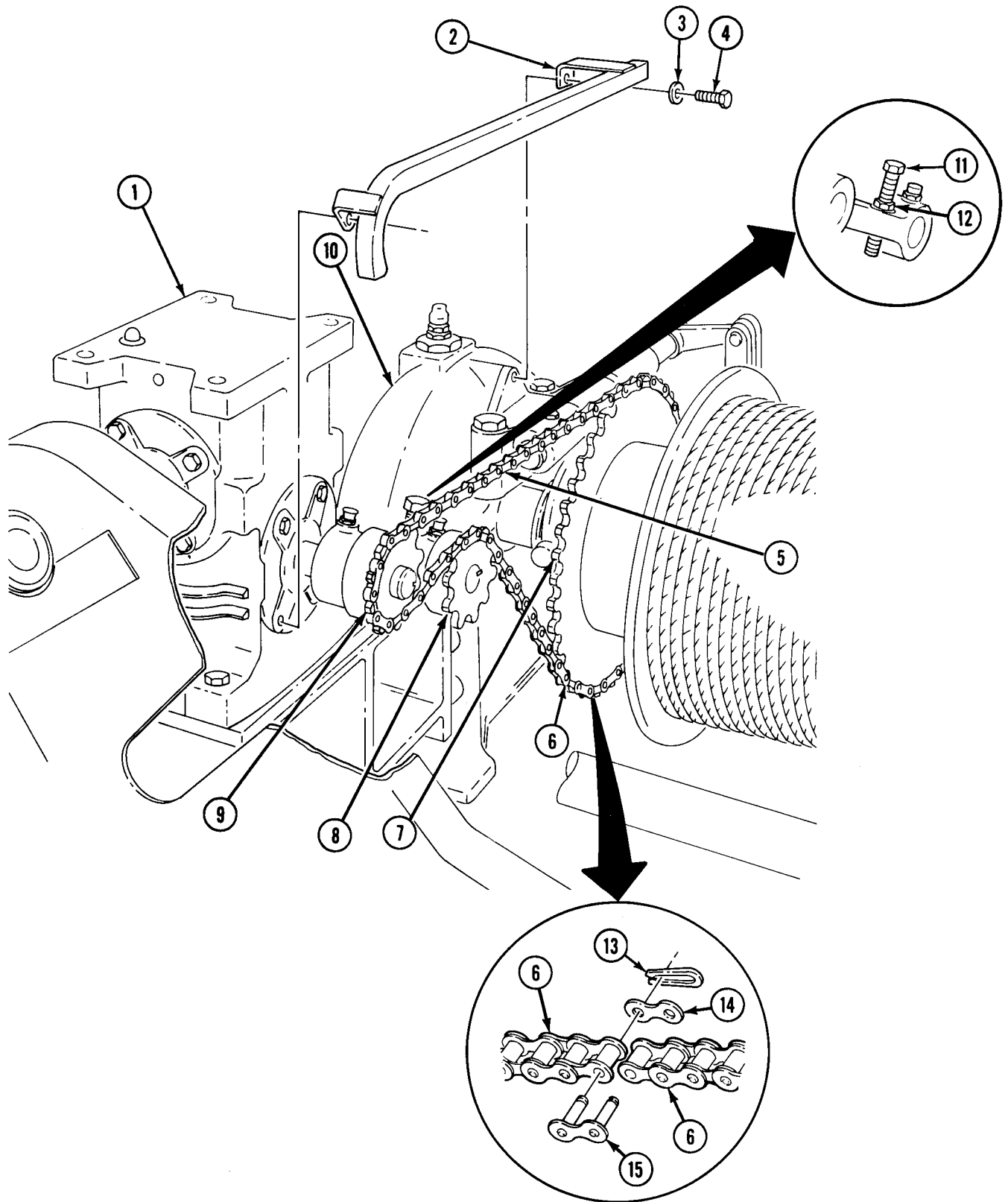

**13-15. SECOND REDUCTION DRIVECHAIN MAINTENANCE (M764)**

This task covers:

- a. Removal
- b. Installation
- c. Adjustment

**INITIAL SETUP:**

**APPLICABLE MODELS**

M764

**MATERIALS/PARTS**

C l i p

Two lockwashers

**REFERENCES (TM)**

TM 9-2320-361-10

TM 9-2320-361-20P

**EQUIPMENT CONDITION**

Parking brake set (TM 9-2320-361-10).

**a. Removal**

1. Remove two screws (9), lockwashers (8), washer (7), and drivechain cover (10) from speed reducer (1) and cross chain cover (6). Discard lockwashers (8).
2. Remove clip (16), keeper (15), master link (14), and drivechain (11) from output shaft sprocket (2), carriage drive sprocket (12), and idler sprocket (5). Discard clip (16).

**b. Installation**

1. Install drivechain (11) on carriage drive sprocket (12), output shaft sprocket (2), and under idler sprocket (5).
2. Install master link (14) and keeper (15) on drivechain (11) with new clip (16).

**c. Adjustment**

**NOTE**

Perform step 1 if reduction drivechain cover has not been removed.

1. Remove two screws (9), lockwashers (8), washer (7), and drivechain cover (10) from speed reducer (1) and cross chain cover (6). Discard lockwashers (8).
2. Loosen jamnut (4) and adjust adjusting nut (3) to obtain 0.5 in. (1.3 cm) freeplay at midpoint (13) of drivechain (11) when pushing up on drivechain (11).
3. Tighten jamnut (4) and ensure adjusting nut (3) does not move.
4. Install drivechain cover (10) to speed reducer (1) and cross chain cover (6) with washer (7) two new lockwashers (8), and screws (9).

13-15. SECOND REDUCTION DRIVECHAIN MAINTENANCE (M764) (Contd)

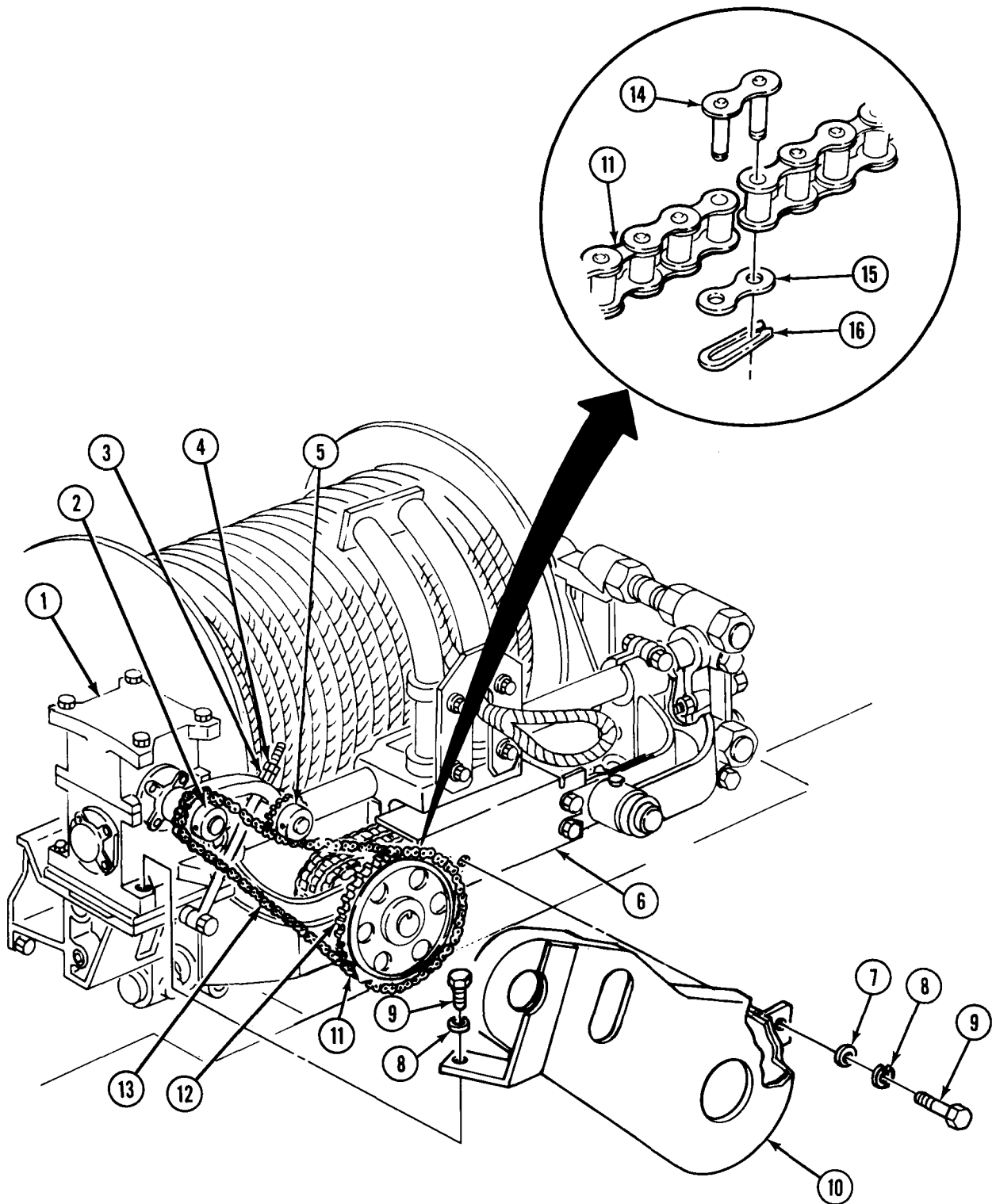



**13-16. REAR WINCH OIL DRAINTUBE REPLACEMENT (M764)**

This task covers:

a. Removal

b. Installation

**INITIAL SETUP:**

**APPLICABLE MODELS**

M764

**MATERIALS/PARTS**

Locknut

**REFERENCES (TM)**

LO 9-2320-209-12-1

TM 9-2320-361-10

TM 9-2320-361-20P

**EQUIPMENT CONDITION**

Parking brake set (TM 9-2320-361-10).

**NOTE**

Have drainage container ready to catch oil.

**a. Removal**

1. Remove pipe plug (6) from elbow (7) and drain oil.
2. Remove locknut (4), screw (9), and clamp (8) from bracket (5). Discard locknut (4).
3. Remove elbow (7), pipe nipple (3), elbow (2), pipe nipple (1), and elbow (10) from worm gear housing (11).

**b. Installation**

1. Install elbow (10), pipe nipple (1), elbow (2), pipe nipple (3), and elbow (7) to worm gear housing (11).
2. Install pipe nipple (3) on bracket (5) with clamp (8), screw (9), and new locknut (4).
3. Install pipe plug (6) on elbow (7).

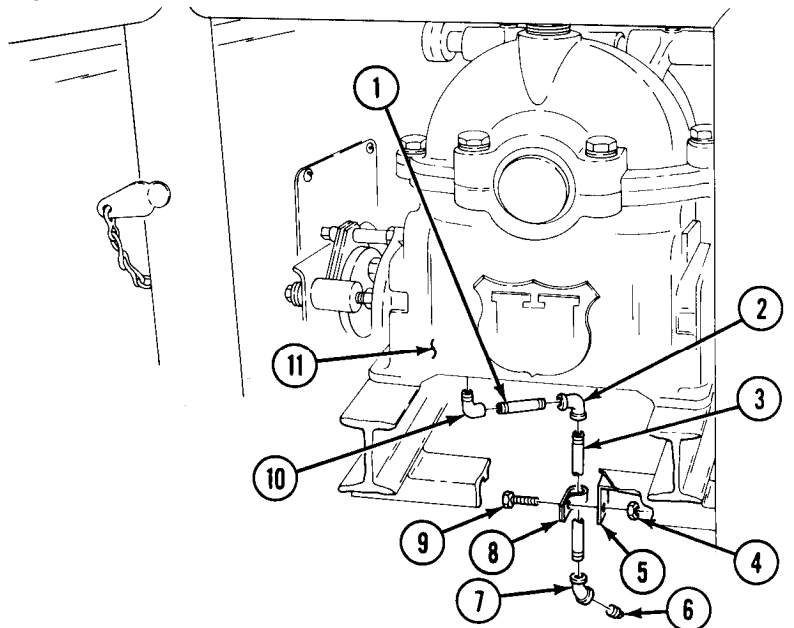

FOLLOW-ON TASK: Fill worm gear housing (LO 9-2320-209-12-1).

## 13-17. REAR WINCH OIL DRAINTUBES REPLACEMENT (M756A2)

This task covers:

- |                                |                                     |
|--------------------------------|-------------------------------------|
| a. Gearcase Draintube Removal  | c. End Frame Draintube Installation |
| b. End Frame Draintube Removal | d. Gearcase Draintube Installation  |

### INITIAL SETUP:

#### APPLICABLE MODELS

M756A2

#### MATERIALS/PARTS

Two locknuts

#### REFERENCES (TM)

LO 9-2320-209-12-1

TM 9-2320-361-10

TM 9-2320-361-20P

#### EQUIPMENT CONDITION

- Parking brake set (TM 9-2320-361-10).
- Rear winch oil drained (LO 9-2320-209-12-1).

### a. Gearcase Draintube Removal

1. Remove two locknuts (2), screws (3), clamp (4), and bracket (11) from pipe (12) and support (14). Discard locknuts (2).
2. Remove elbow (5), pipe (12), and elbow (13) from gearcase (1).

### b. End Frame Draintube Removal

Remove elbow (10), pipe (9), elbow (8), and pipe (7) from end frame (6).

### c. End Frame Draintube Installation

Install pipe (7), elbow (8), pipe (9), and elbow (10) on end frame (6).

### d. Gearcase Draintube Installation

1. Install elbow (13), pipe (12), and elbow (5) on gearcase (1).
2. Install clamp (4) and bracket (11) on pipe (12) and support (14) with two screws (3) and new locknuts (2).

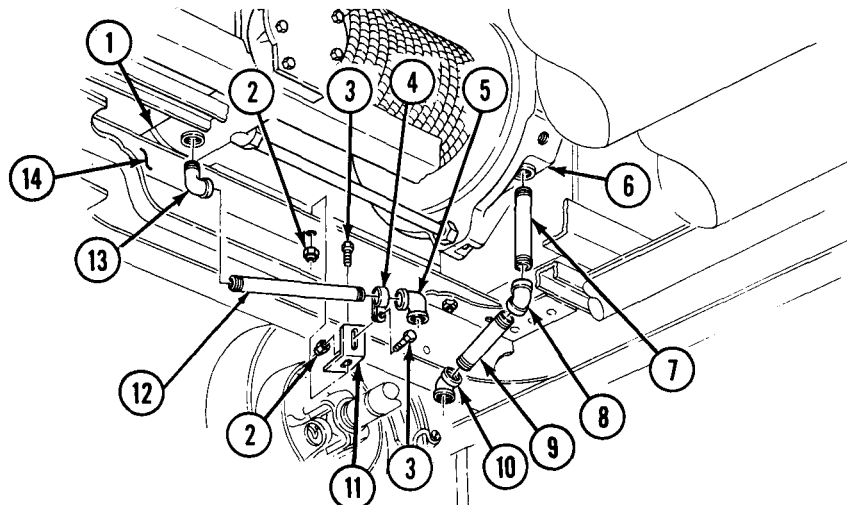

FOLLOW-ON TASK: Install drainplugs and fill rear winch (LO 9-2320-209-12-1).

**13-18. REAR WINCH REPLACEMENT (M756A2)**

This task covers:

- a. Removal b. Installation

**INITIAL SETUP:**

**APPLICABLE MODELS**

M756A2

**MATERIAL/PARTS**

Two cotter pins  
 Ten locknuts  
 Eight lockwashers  
 Two plugs

**PERSONNEL REQUIRED**

Two

**REFERENCES (TM)**

LO 9-2320-209-12-1  
 TM 9-2320-361-10  
 TM 9-2320-361-20P

**EQUIPMENT CONDITION**

- Parking brake set (TM 9-2320-361-10).
- Rear winch cable removed (para. 13-10).
- Rear winch drivechain removed (para. 13-11).
- Cab protector removed (para. 12-85).
- Rear winch draintubes removed (para. 13-16).

**GENERAL SAFETY INSTRUCTIONS**

All personnel must stand clear during lifting operations.

**a. Removal**

1. Remove six locknuts (7), washers (8), screws (10), and washers (8) from two winch brackets (9) and frame extensions (5). Discard locknuts (7).

**WARNING**

All personnel must stand clear during lifting operations. A swinging or shifting load may result in injury to personnel.

**NOTE**

Assistant will help with steps 2 and 3.

2. Secure chain sling (1) to rear winch (3) and lifting device (2). Remove rear winch (3) and two spacers (4) from frame (6).
3. Lower rear winch (3) approximately 1 in. (2.5 cm) from ground.
4. Remove four locknuts (22), screws (25), and two winch supports (26) from winch brackets (9). Discard locknuts (22).
5. Remove eight screws (27), lockwashers (28), and two winch brackets (9) from rear winch (3). Discard lockwashers (28).
6. Lower rear winch (3) to ground and remove chain sling (1) from rear winch (3) and lifting device (2).
7. Remove two plugs (15) from sprocket (14). Discard plugs (15).
8. Remove two cotter pins (11) and shearpin (13) from hub (12) and sprocket (14). Discard cotter pins (11). Discard shearpin (13) if damaged.
9. Remove retainer ring (18) from hub (12) and turn sprocket (14) 90° to aline straight pin (16) with holes in sprocket (14) and hub (12).
10. Remove straight pin (16), hub (12), bushing (21), sprocket (14), spacer (19), and retaining ring (18) from rear winch shaft (17).
11. Remove grease fitting (20) from sprocket (14).
12. Remove plug (23) and elbow (24) from winch (3).

**13-18. REAR WINCH REPLACEMENT (M756A2) (Contd)**

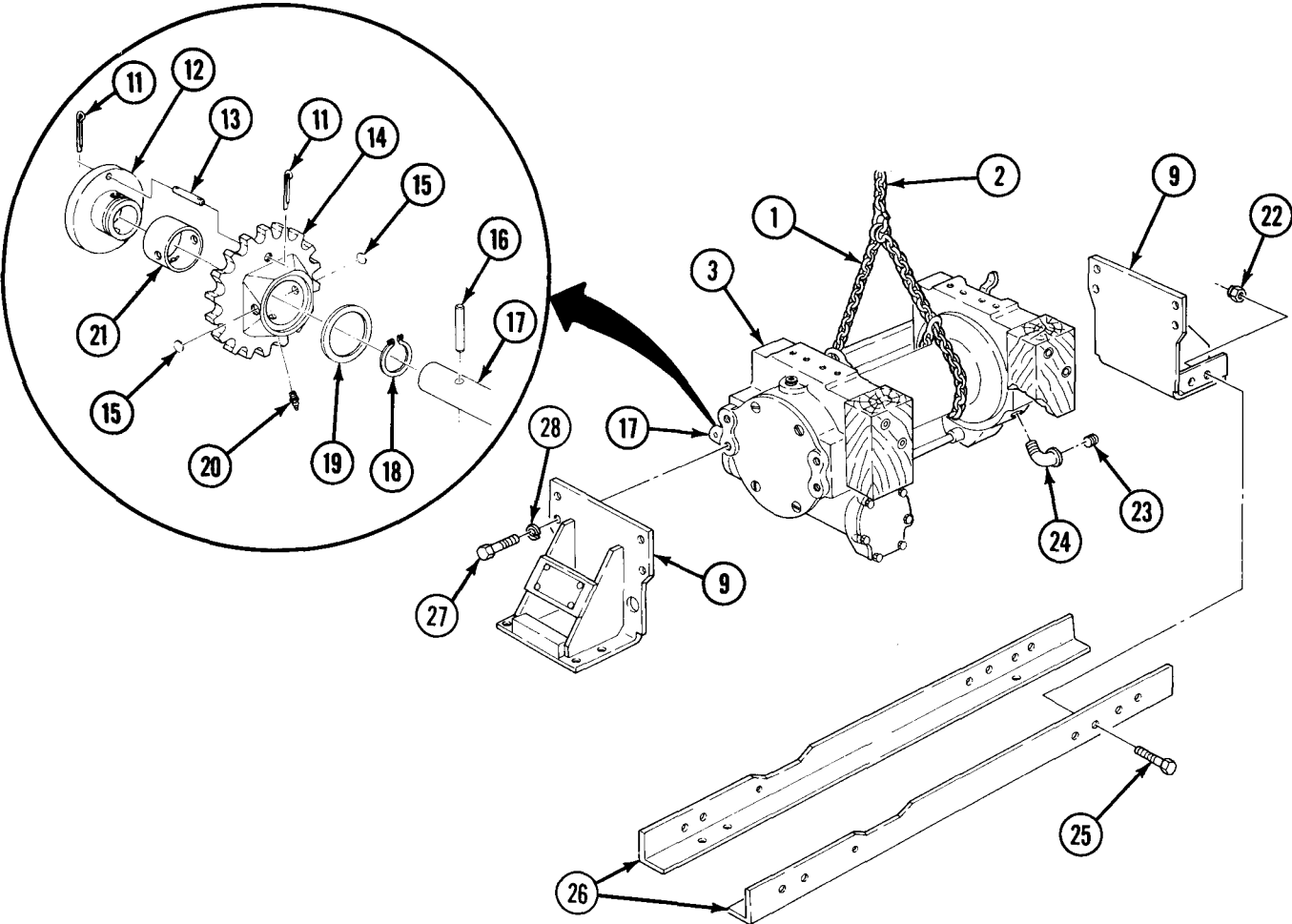
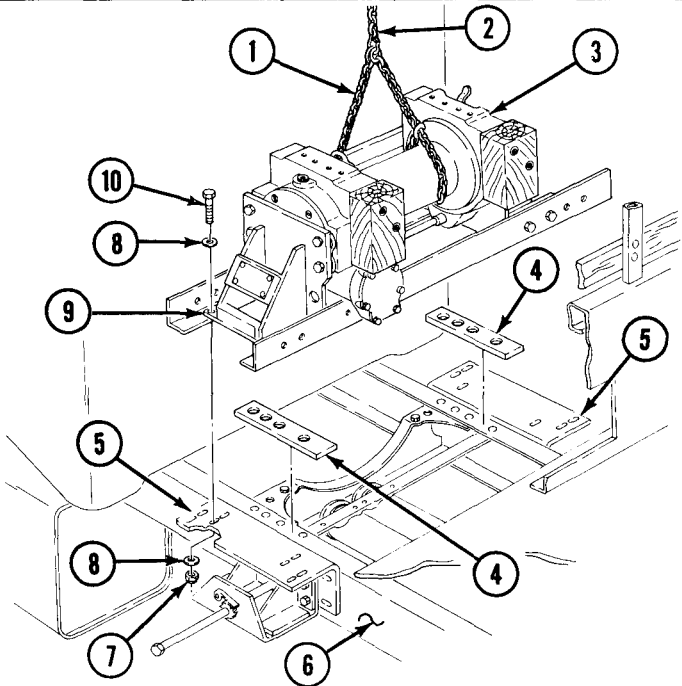

## 13-18.REAR WINCH REPLACEMENT (M756A2) (Contd)

### b. Installation

#### NOTE

Rotate winch drum on new rear winch, one complete revolution to ensure new rear winch moves freely without binding. Operate drum clutch lock lever to ensure proper operation. If new rear winch does not operate correctly, replace new rear winch.

1. Install elbow (7) and plug (6) on winch (1).
2. Install grease fitting (21) on sprocket (15) if removed.
3. Install hub (13), bushing (22), spacer (20), and retaining ring (19) on sprocket (15).
4. Install sprocket (15) on rear winch shaft (18).
5. Aline holes in sprocket (15) with holes in hub (13), and install straight pin (17) and two new plugs (16).
6. Turn sprocket (15) 90° and install shearpin (14) through hub (13) and sprocket (15) with two new cotter pins (12).

#### NOTE

Assistant will help with step 7.

7. Secure chain sling (2) to rear winch (1) and lifting device (3), and raise rear winch (1) approximately 1 in. (2.5 cm) from ground.
8. Install two winch brackets (4) on rear winch (1) with eight new lockwashers (11) and screws (10).
9. Install two supports (9) on two winch brackets (4) with four screws (8) and new locknuts (5).

#### NOTE

Assistant will help with steps 10 and 11.

10. Install two spacers (23) on frame (25) and install rear winch (1) on frame (25) with lifting device (3).
11. Install six washers (27), screws (28), washers (27), and new locknuts (26) on two winch brackets (4) and frame extensions (24).

**13-18. REAR WINCH REPLACEMENT (M756A2) (Contd)**

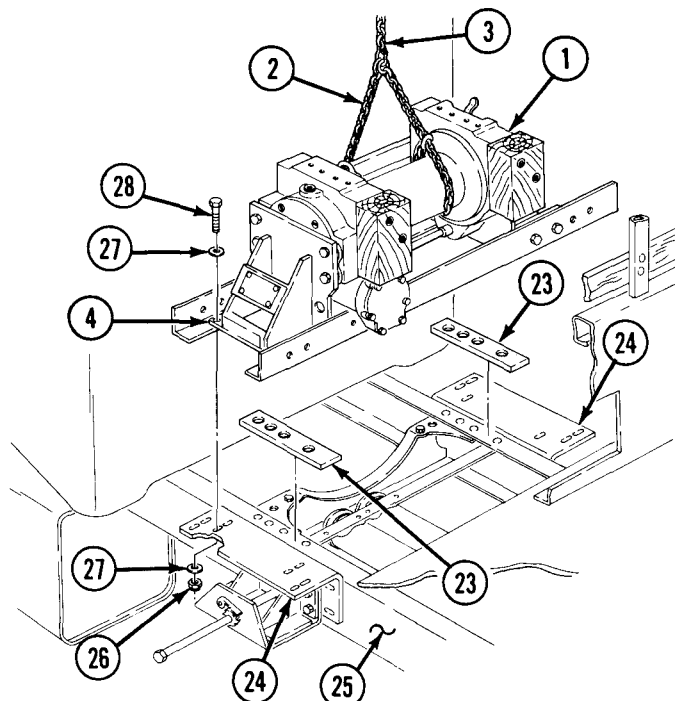
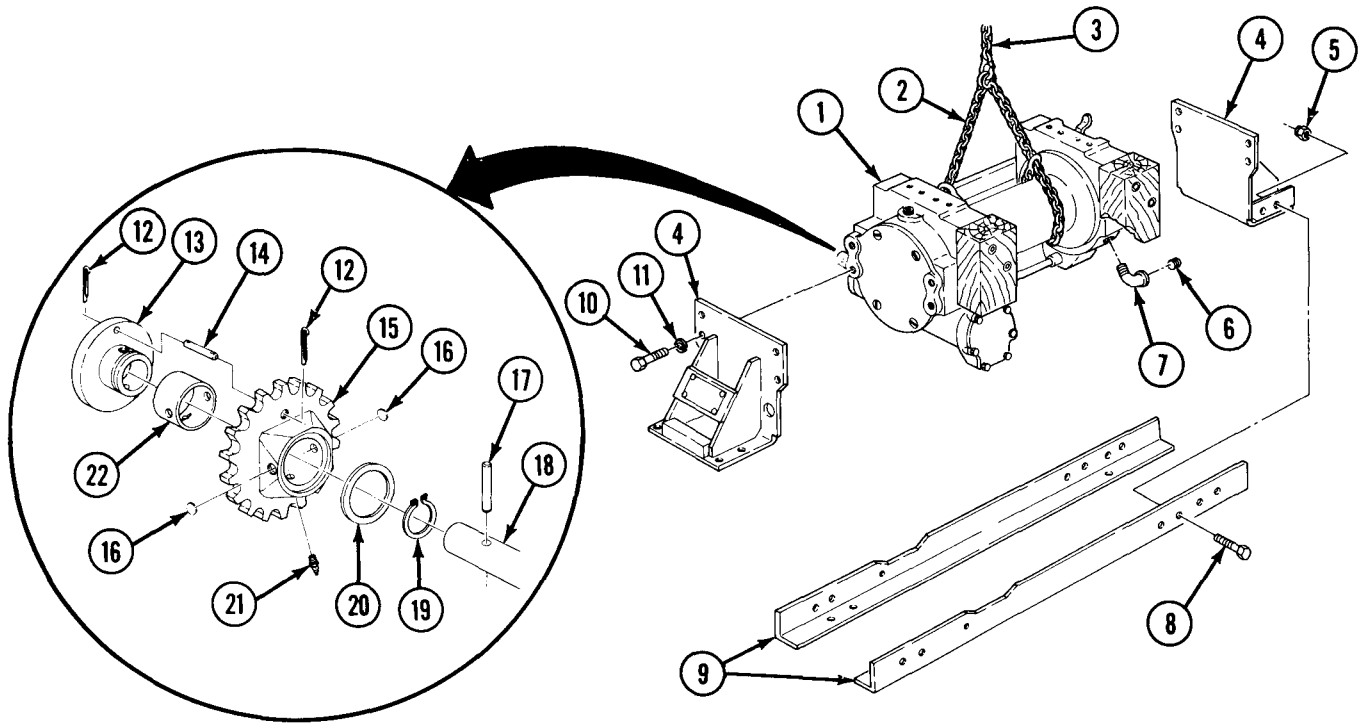

- FOLLOW-ON TASKS:**
- Install rear winch draitubes (para. 13-16).
  - Install cab protector (para. 12-85).
  - Install rear winch drivechain (para. 13-11).
  - Install rear winch cable (para. 13-10).
  - Adjust automatic brake and test (para. 13-4).
  - Lubricate rear winch sprocket (LO 9-2320-209-12-1).

**Section II. POWER TAKEOFF CONTROLS AND LINKAGE MAINTENANCE**

**13-19. POWER TAKEOFF CONTROLS AND LINKAGE MAINTENANCE INDEX**

PARA. NO.	TITLE	PAGE NO.
13-20.	Transmission Power Takeoff (PTO) Shift Linkage Maintenance	13-34
13-21.	Power Divider Propeller Shaft Replacement (M764)	13-36
13-22.	Hydraulic Hoist Control Linkage Maintenance (M342A2)	13-38
13-23.	Power Divider Control Lever and Linkage Replacement (M764)	13-40

**13-20. TRANSMISSION POWER TAKEOFF (PTO) SHIFT LINKAGE MAINTENANCE**

This task covers:

- |               |                 |
|---------------|-----------------|
| a. Removal    | c. Adjustment   |
| b. Inspection | d. Installation |

**INITIAL SETUP:**

APPLICABLE MODELS

All

MATERIALS/PARTS

Three locknuts  
Cotter pin  
Screw-assembled lockwasher

REFERENCES (TM)

TM 9-2320-361-10  
TM 9-2320-361-20P

EQUIPMENT CONDITION

Parking brake set (TM 9-2320-361-10).

**a. Removal**

1. Remove screw-assembled lockwasher (4) from vehicle floor (6) and open master cylinder access door (5). Discard screw-assembled lockwasher (4).
2. Remove two locknuts (3), screws (2), and hinge lock (1) from cab floor (6). Discard locknuts (3).
3. Remove cotter pin (10) and clevis pin (18) from shift rod (12) and transmission PTO lever (19) and clevis (11). Discard cotter pin (10).
4. Remove locknut (9), screw (8), and transmission PTO lever (19) from support (21). Discard locknut (9).
5. Remove two screws (7) and support (21) from master cylinder (20).
6. Pull clevis pin (17) out far enough to allow shifting rod (12) to be removed from PTO arm (14).
7. Remove clevis pin (17), ball (15), and spring (16) from clevis (13). Remove shift rod (12).

**b. Inspection**

Inspect all parts for bends, breaks, or cracks, and ball (15) for roundness. Replace damaged parts.

**c. Adjustment**

Install spring (16), ball (15), and clevis pin (17) to clevis (13) and PTO arm (14) and adjust shift rod (12) to measure 5.63 in. (14.3 cm) from centers of clevis (13) and clevis (11).

**13-20. TRANSMISSION POWER TAKEOFF (PTO) SHIFT LINKAGE MAINTENANCE (Contd)**

**d. Installation**

1. Install shift rod (12) to PTO arm (14) with clevis pin (17).
2. Install support (21) to master cylinder (20) with two screws (7).
3. Install transmission PTO lever (19) to support (21) with screw (8) and new locknut (9).
4. Connect shift rod (12) to transmission PTO lever (19) with clevis pin (18) and new cotter pin (10).
5. Install hinge lock (1) to cab floor (6) with two screws (2) and new locknuts (3).
6. Close master cylinder access door (5) and secure to vehicle floor (6) with new screw-assembled lockwasher (4).

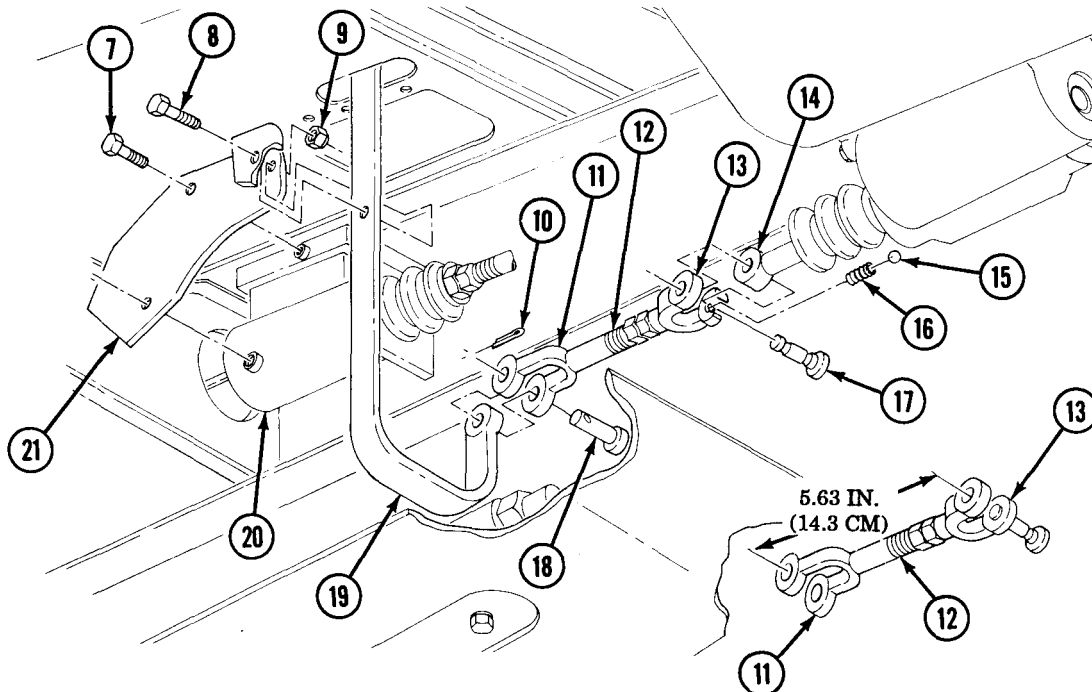
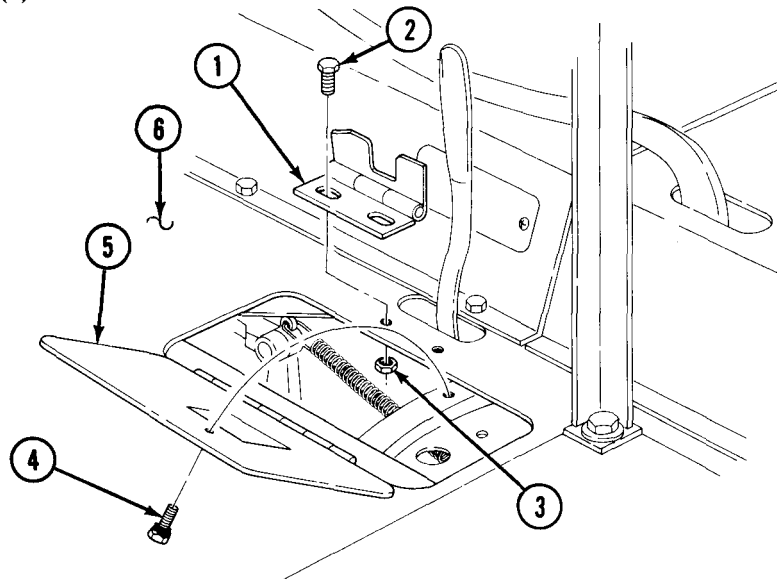



**13-21. POWER DIVIDER PROPELLER SHAFT REPLACEMENT (M764)**

This task covers:

- a. Removal
- b. Inspection

c. Installation

**INITIAL SETUP:**

APPLICABLE MODELS

M764

MATERIALS/PARTS

Eight lockwashers

Seal

GAA grease (Appendix C, Item 13)

REFERENCES (TM)

LO 9-2320-209-12-1

TM 9-2320-361-10

TM 9-2320-361-20P

EQUIPMENT CONDITION

Parking brake set (TM 9-2320-361-10).

**a. Removal**

1. Remove four nuts (2), lockwashers (3), screws (4), and yoke shaft (5) from flange (1). Discard lockwashers (3).
2. Remove four nuts (12), lockwashers (11), two U-bolts (9), and yoke shaft (5) from end yoke (13). Discard lockwashers (11).
3. Unscrew cap (6) from end yoke sleeve (10).
4. Remove seal (8) and washer (7) from cap (6). Discard seal (8).

**b. Inspection**

Inspect all parts for cracks, bends, or breaks. Replace defective parts. If universal joint requires additional maintenance, refer to para. 7-4.

**c. Installation**

1. Apply light coat of GAA grease to splines on yoke shaft (5).
2. Install cap (6), washer (7), new seal (8), and end yoke sleeve (10) on yoke shaft (5).
3. Tighten cap (6) on end yoke sleeve (10).
4. Tighten end yoke sleeve (10) on end yoke (13) with two U-bolts (9), four new lockwashers (11), and nuts (12). Tighten nuts (12) 25-29 lb-ft (34-39 N·m).
5. Connect yoke shaft (5) on flange (1) with four screws (4), new lockwashers (3), and nuts (2).

**13-21. POWER DIVIDER PROPELLER SHAFT REPLACEMENT (M764) (Contd)**

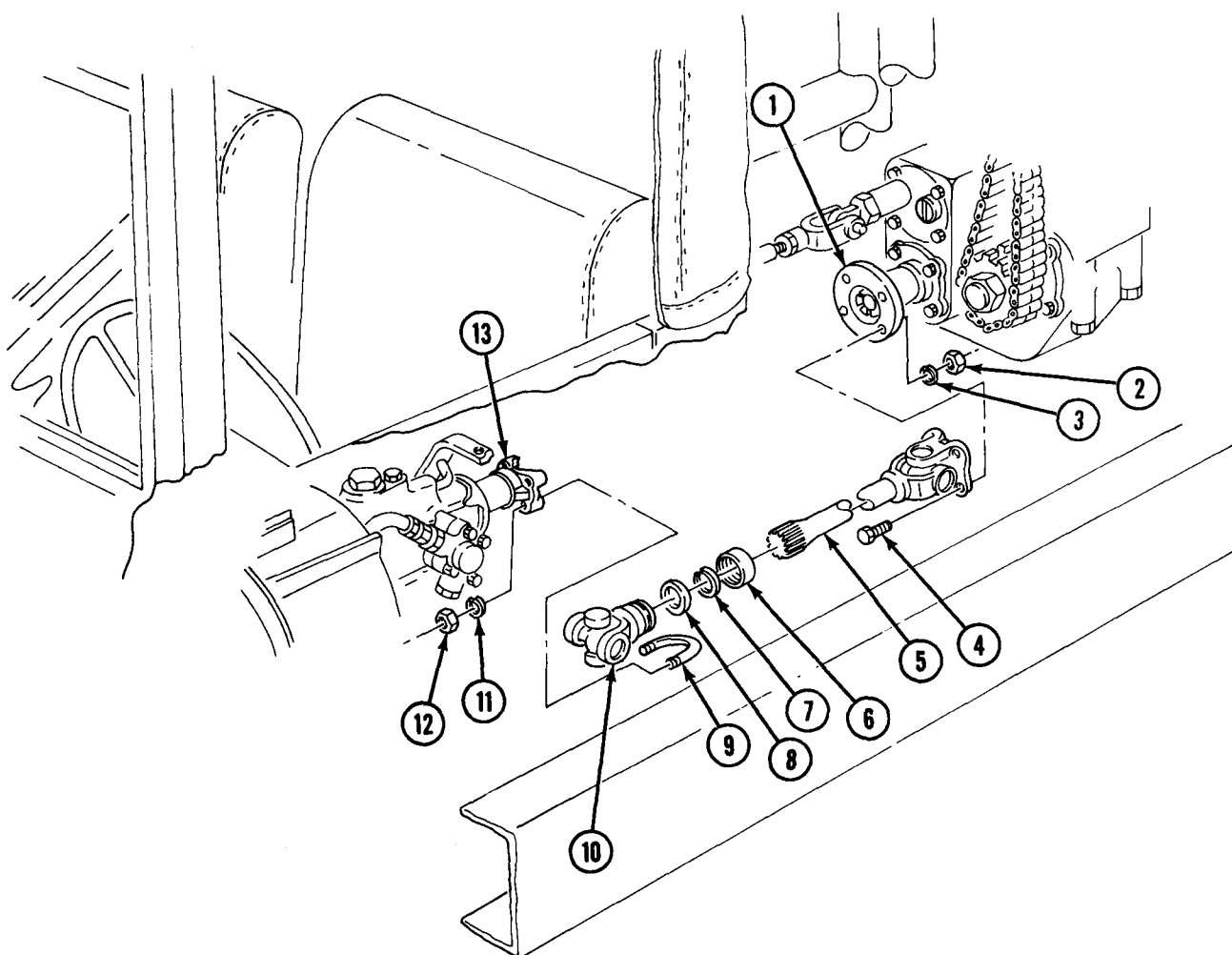

FOLLOW-ON TASK: Lubricate universal joints (LO 9-2320-209-12-1).

**13-22. HYDRAULIC HOIST CONTROL LINKAGE MAINTENANCE (M342A2)**

This task covers:

- a. Removal
- b. Inspection

c. Installation

INITIAL SETUP:

APPLICABLE MODELS

M342A2

MATERIALS/PARTS

Four cotter pins

REFERENCES (TM)

TM 9-2320-361-10

TM 9-2320-361-20P

EQUIPMENT CONDITION

Parking brake set (TM 9-2320-361-10).

**a. Removal**

1. Remove cotter pin (11) and clevis pin (9) from PTO rod arm (10) and clevis (8). Discard cotter pin (11).
2. Remove cotter pin (18) and clevis pin (16) from clevis (15) and hoist control valve arm (17). Discard cotter pin (18).
3. Loosen jamnuts (14) and (7) and remove clevises (8) and (15) from control link (12) and two crossmembers (1).
4. Remove cotter pin (19) and clevis pin (21) from hoist control valve arm (20) and clevis (2). Discard cotter pin (19).
5. Remove cotter pin (13), clevis pin (5), control rod (3), and clevis (4) from hoist control lever (6). Discard cotter pin (13).

**b. Inspection**

Inspect control link (12), control link clevises (15) and (8), control rod (3), and control rod clevises (2) and (4) for bends, breaks, or cracks. If damaged, replace.

**c. Installation**

1. Ensure hoist control lever (6) is in LOCK position (refer to TM 9-2320-361-10), and install clevis (4) to control lever (6) with clevis pin (5) and new cotter pin (13).
2. Install control link (12) through two crossmembers (1) and install clevises (8) and (15) on control link (12).
3. Ensure hoist control valve arm (20) is in most forward position. Adjust clevis (2) so clevis pin (21) can be installed freely through clevis (2) and hoist control valve arm (20). Connect clevis (2) to hoist control valve arm (20) with clevis pin (21) and new cotter pin (19).
4. Ensure hoist control valve arm (17) is completely forward in lock position and install clevis (15) to valve arm (17) with clevis pin (16) and new cotter pin (18).
5. Ensure PTO rod arm (10) is in NEUTRAL position and adjust clevis (8) so clevis pin (9) can be installed freely through clevis (8) and PTO rod arm (10). Connect clevis (8) on PTO rod arm (10) with clevis pin (9) and new cotter pin (11).
6. Tighten jamnuts (14) and (7).

13-22. HYDRAULIC HOIST CONTROL LINKAGE MAINTENANCE (M342A2) (Contd)

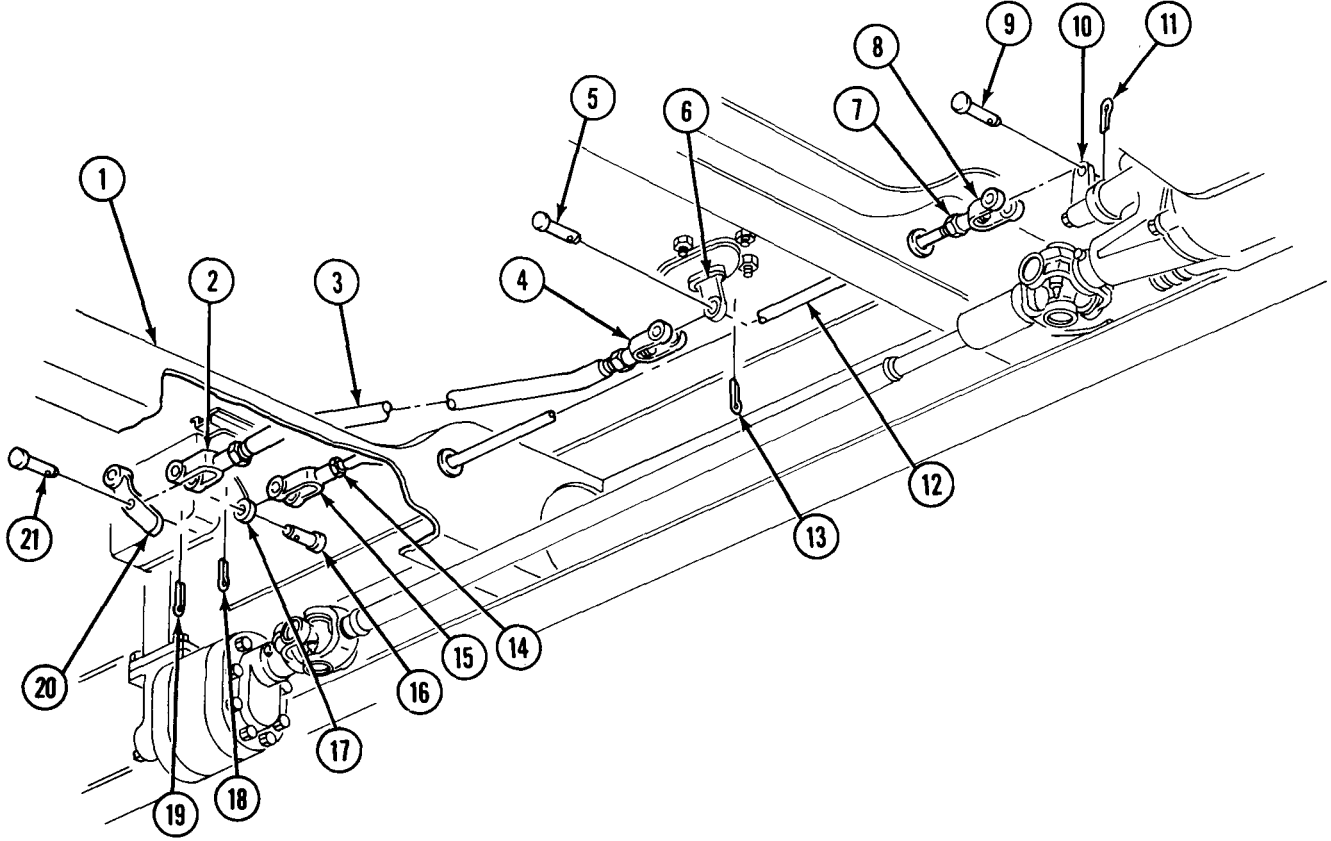

**13-23. POWER DIVIDER CONTROL LEVER AND LINKAGE REPLACEMENT (M764)**

This task covers:

- a. Removal
- b. Installation

c. Adjustment

**INITIAL SETUP:**

APPLICABLE MODELS

M764

REFERENCES (TM)

TM 9-2320-361-10

TM 9-2320-361-20P

MATERIALS/PARTS

Two cotter pins

Locknut

EQUIPMENT CONDITION

Parking brake set (TM 9-2320-361-10).

**a. Removal**

1. Remove cotter pin (3), clevis pin (1), and control rod (5) from power divider shaft (2). Discard cotter pin (3).
2. Remove cotter pin (14), clevis pin (11), and control rod (5) from control lever (12). Discard cotter pin (14).
3. Remove locknut (10), screw (7), washer (13), spacer (8), and control lever (12) from bracket (9). Discard locknut (10).

**b. Installation**

Install control lever (12) to bracket (9) with spacer (8), washer (13), screw (7), and new locknut (10).

**c. Adjustment**

1. Adjust control rod (5) to 42.5 in. (108 cm) from center of both clevis holes (6) and (4).
2. Install control lever (5) to power divider shaft (2) with clevis pin (1) and new cotter pin (3).
3. Connect control rod (5) to control lever (12) with clevis pin (11) and new cotter pin (14).

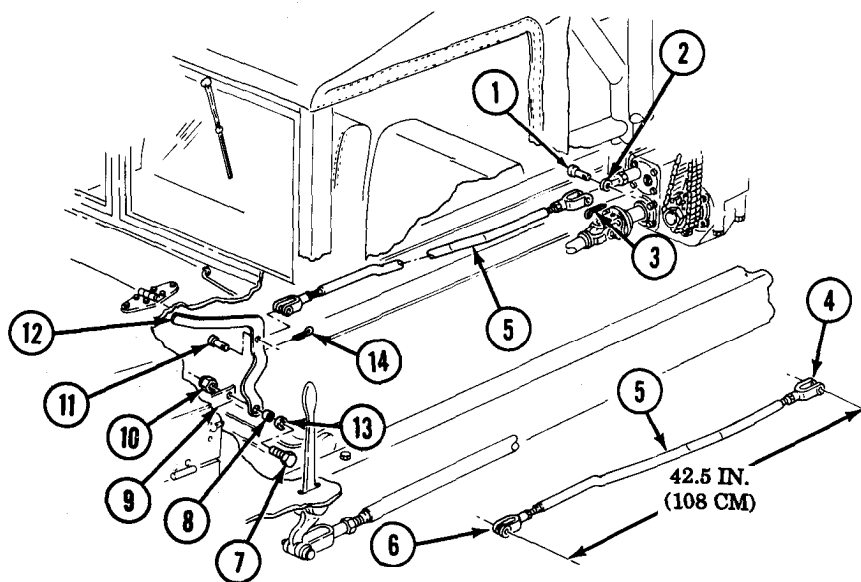

## CHAPTER 14

### SPECIAL PURPOSE KITS MAINTENANCE

Section I.	Winterization Kits Maintenance (page 14-1)
Section II.	Van Body Primary and Secondary Heater Kit Maintenance (page 14-36)
Section III.	Deep Water Fording Kit Maintenance (page 14-60)
Section IV.	A-Frame Kit Maintenance (page 14-66)
Section V.	Mounting Kits Maintenance (page 14-70)
Section VI.	100 Amp Alternator Kit Maintenance (page 14-85)
Section VII.	Troop Seat Mounting Kit Maintenance (page 14-92)

### Section I. WINTERIZATION KITS MAINTENANCE

#### 14-1. WINTERIZATION KITS MAINTENANCE INDEX

PARA. NO.	TITLE	PAGE NO.
14-2.	Fuel Burning Personnel Heater Replacement	14-2
14-3.	Personnel Heater Control Box Replacement	14-3
14-4.	Personnel Heater Fuel Pump Replacement	14-4
14-5.	Personnel Heater Fuel Filter Replacement	14-6
14-6.	Exhaust Tube Replacement	14-8
14-7.	Oil Pan Shroud and Exhaust Tube Replacement	14-9
14-8.	Engine Coolant Heater Replacement	14-10
14-9.	Engine Coolant Heater Harness Replacement	14-12
14-10.	Thermal Barrier Insulation Replacement	14-14
14-11.	Battery Box Heater Pad Replacement	14-16
14-12.	Transmission Gearshift and Transfer Case Lever Cover Replacement	14-17
14-13.	Hood and Radiator Cover Replacement	14-18
14-14.	Hardtop Maintenance	14-20
14-15.	Alcohol Evaporator Replacement	14-22
14-16.	Slave Receptacle Replacement	14-24
14-17.	Cargo Body Personnel Heater Replacement	14-26
14-18.	Cargo Body Personnel Heater Mounting Bracket Replacement	14-28
14-19.	Cargo Body Personnel Heater Fuel Pump Replacement	14-29
14-20.	Cargo Body Personnel Heater Fuel Filter Replacement	14-30
14-21.	Cargo Body Personnel Heater Control Box Replacement	14-31
14-22.	Cargo Body Personnel Heater Fuel Line Replacement	14-32
14-23.	Cargo Body Personnel Heater Diverter and Duct Replacement	14-34

**14-2. FUEL BURNING PERSONNEL HEATER REPLACEMENT**

This task covers:

**a. Removal**

**b. Installation**

**INITIAL SETUP:**

APPLICABLE MODELS

All

MATERIALS/PARTS

Cotter pin  
Four lockwashers

REFERENCES (TM)

TM 9-2320-361-10  
TM 9-2320-361-20P

EQUIPMENT CONDITION

- Parking brake set (TM 9-2320-361-10).
- Hood raised and secured (TM 9-2320-361-10).
- Battery ground cable disconnected (para. 4-48).

**a. Removal**

1. Disconnect wiring harness (1) from personnel heater (2).
2. Remove fuel line (4) from elbow (3) and personnel heater (2).
3. Remove elbow (3) from personnel heater (2).
4. Remove cotter pin (9) and disconnect exhaust tube (10) from personnel heater (2). Discard cotter pin (9).
5. Remove four screws (6), lockwashers (7), and adapter (5) from personnel heater (2). Discard lockwashers (7).
6. Remove two clamps (8) and personnel heater (2) from mount (11).

**b. Installation**

1. Install heater (2) on mount (11) with two clamps (8).
2. Install adapter (5) on personnel heater (2) with four new lockwashers (7) and screws (6).
3. Install elbow (3) on personnel heater (2).
4. Install exhaust tube (10) on personnel heater (2) and insert new cotter pin (9) through tube (10) and personnel heater (2).
5. Install fuel line (4) on elbow (3).
6. Connect wiring harness (1) to personnel heater (2).

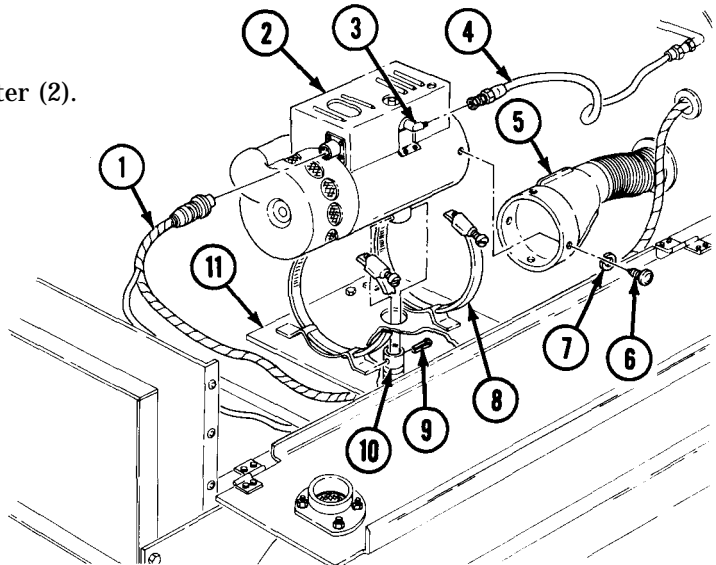

- FOLLOW-ON TASKS:**
- Connect battery ground cable (para. 4-48).
  - Start heater and check operation (TM 9-2320-361-10).

## 14-3. PERSONNEL HEATER CONTROL BOX REPLACEMENT

This task covers:

### a. Removal

### b. Installation

INITIAL SETUP:

#### APPLICABLE MODELS

All

#### REFERENCES (TM)

TM 9-2320-361-10

TM 9-2320-361-20P

#### MATERIALS/PARTS

Two lockwashers

#### EQUIPMENT CONDITION

- Parking brake set (TM 9-2320-361-10).
- Battery ground cable disconnected (para. 4-48).

#### NOTE

This procedure is the same for the engine coolant heater control box.

### a. Removal

1. Disconnect wiring harness (4) from control box (7).
2. Disconnect wire (6) from wire (5).
3. Remove two nuts (2), lockwashers (1), and control box (7) from bracket (3). Discard lockwashers (1).

### b. Installation

1. Install control box (7) on bracket (3) with two new lockwashers (1) and nuts (2).
2. Connect wire (6) to wire (5).
3. Connect wiring harness (4) to control box (7).

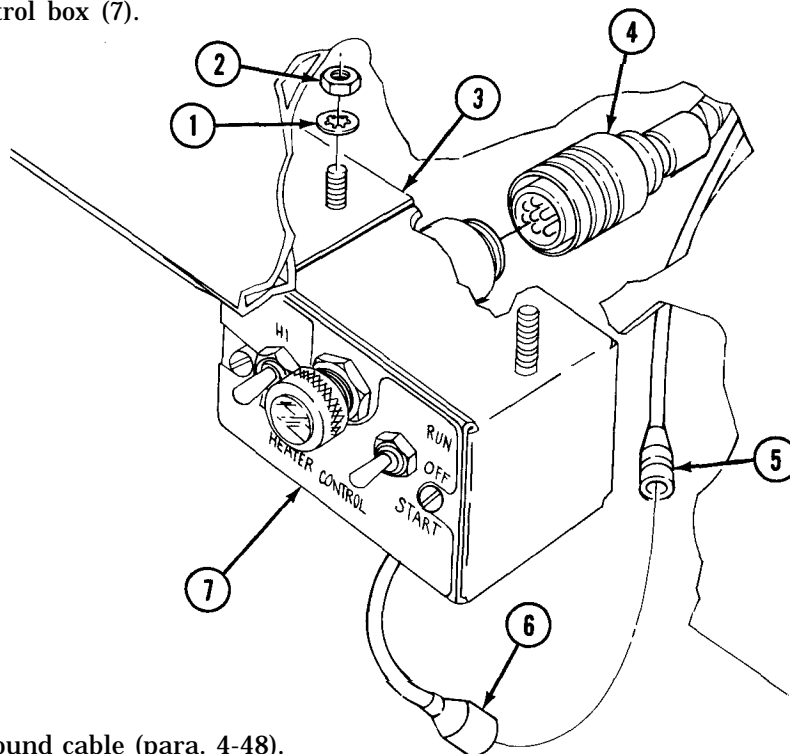

FOLLOW-ON TASK: Connect battery ground cable (para. 4-48).



**14-4. PERSONNEL HEATER FUEL PUMP REPLACEMENT**

This task covers:

**a. Removal**

**b. Installation**

**INITIAL SETUP:**

APPLICABLE MODELS

MATERIALS/PARTS

Two lockwashers  
Cap and plug set (Appendix C, Item 8)

REFERENCES (TM)

TM 9-2320-361-10  
TM 9-2320-361-20P

EQUIPMENT CONDITION

- Parking brake set (TM 9-2320-361-10).
- Battery ground cable disconnected (para. 4-48).

GENERAL SAFETY INSTRUCTIONS

Diesel fuel is flammable. Do not perform this procedure near open flames.

**WARNING**

Do not perform this procedure while smoking or within 50 feet of sparks or open flame. Fuel is flammable and can explode easily, causing injury or death to personnel and damage to equipment.

**a. Removal**

1. Disconnect wire (6) from wire (5).

**CAUTION**

Cap or plug all hoses, connections, and openings immediately after disconnection to prevent contamination. Failure to do so may result in damage to equipment.

2. Disconnect inlet line (3) from fuel pump (11).
3. Disconnect outlet line (1) from elbow (2).
4. Remove elbow (2) from fuel pump (11).
5. Remove two screws (7), lockwashers (8), clamp (10), ground wire (9), and fuel pump (11) from plate (4). Discard lockwashers (8).

**b. Installation**

**CAUTION**

Remove caps or plugs from hoses, connections, and openings before reconnection. Failure to do so may result in damage to equipment.

1. Install fuel pump (11), ground wire (9), and clamp (10) on plate (4) with two new lockwashers (8) and screws (7).
2. Install elbow (2) on fuel pump (11).
3. Connect outlet line (1) to elbow (2).
4. Connect inlet line (3) to fuel pump (11).
5. Connect wire (6) to wire (5).

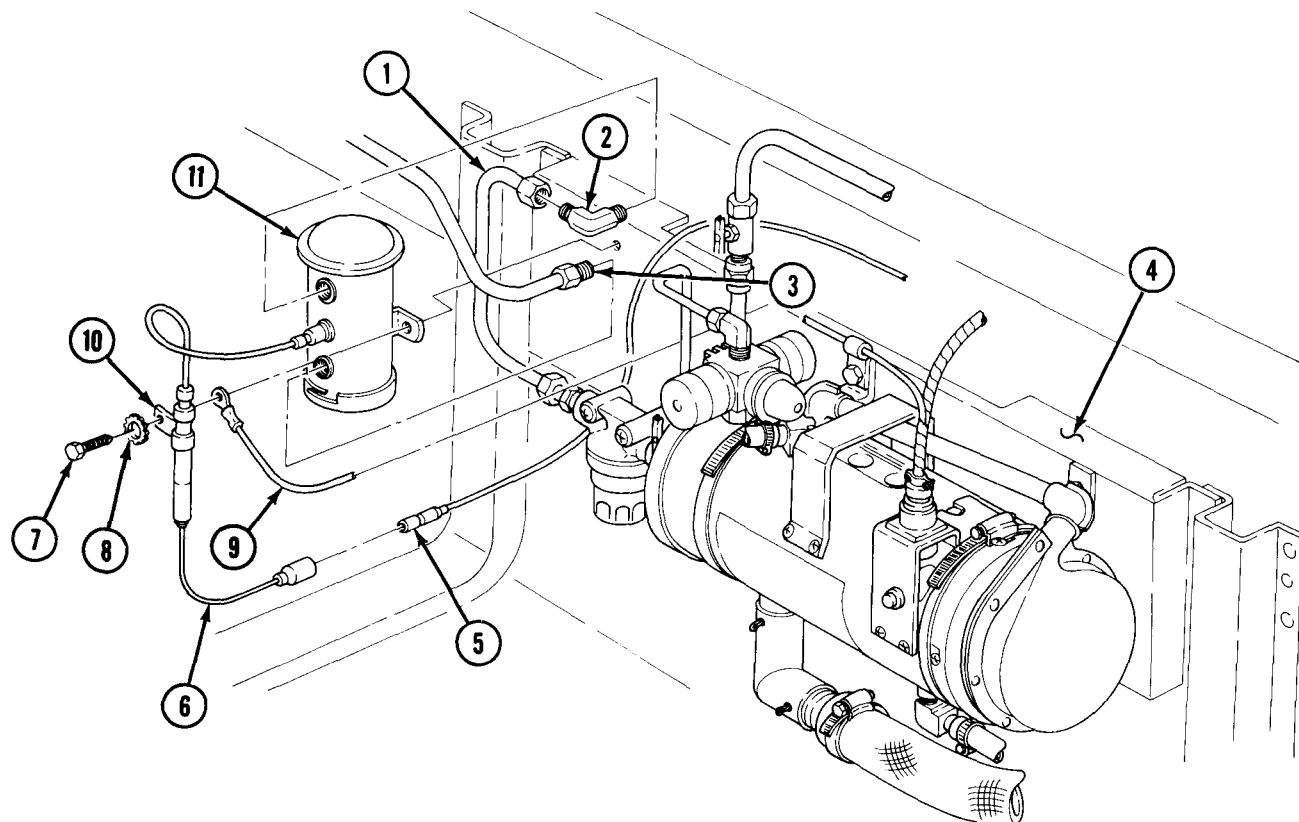
**14-4. PERSONNEL HEATER FUEL PUMP REPLACEMENT (Contd)**

FOLLOW-ON TASK: Connect battery ground cable (para. 4-48).

**14-5. PERSONNEL HEATER FUEL FILTER REPLACEMENT**

This task covers:

**a. Removal**

**b. Installation**

INITIAL SETUP:

APPLICABLE MODELS

All

MATERIALS/PARTS

Two lockwashers  
Antiseize tape (Appendix C, Item 27)

REFERENCES (TM)

TM 9-2320-361-10  
TM 9-2320-361-20P

EQUIPMENT CONDITION

- Parking brake set (TM 9-2320-361-10).
- Hood raised and secured (TM 9-2320-361-10).

**a. Removal**

1. Disconnect tube (11) from fuel pump elbow (1) and adapter (10).
2. Disconnect fuel line (3) from tube (4).
3. Disconnect tube (4) from elbow (5).
4. Remove elbow (5) from tee (6).

**NOTE**

Perform step 5 if vehicle is equipped with engine coolant heater.

5. Disconnect fuel line (12) from tee (6).
6. Remove tee (6) from fuel filter (7).
7. Remove two screws (8), lockwashers (9), and fuel filter (7) from plate (2). Discard lockwashers (9).
8. Remove adapter (10) from fuel filter (7).

**b. Installation**

**NOTE**

Wrap male pipe threads with antiseize tape prior to installation.

1. Install adapter (10) on fuel filter (7).
2. Install fuel filter (7) on plate (2) with two new lockwashers (9) and screws (8).
3. Install tee (6) on fuel filter (7).
4. Install elbow (5) on tee (6).
5. Connect fuel line (3) to tube (4).

**NOTE**

Perform step 6 if vehicle is equipped with engine coolant heater.

6. Connect two fuel lines (12) and (4) to tee (6).
7. Connect tube (11) to fuel pump elbow (1) and adapter (10).

14-5. PERSONNEL HEATER FUEL FILTER REPLACEMENT (Contd)

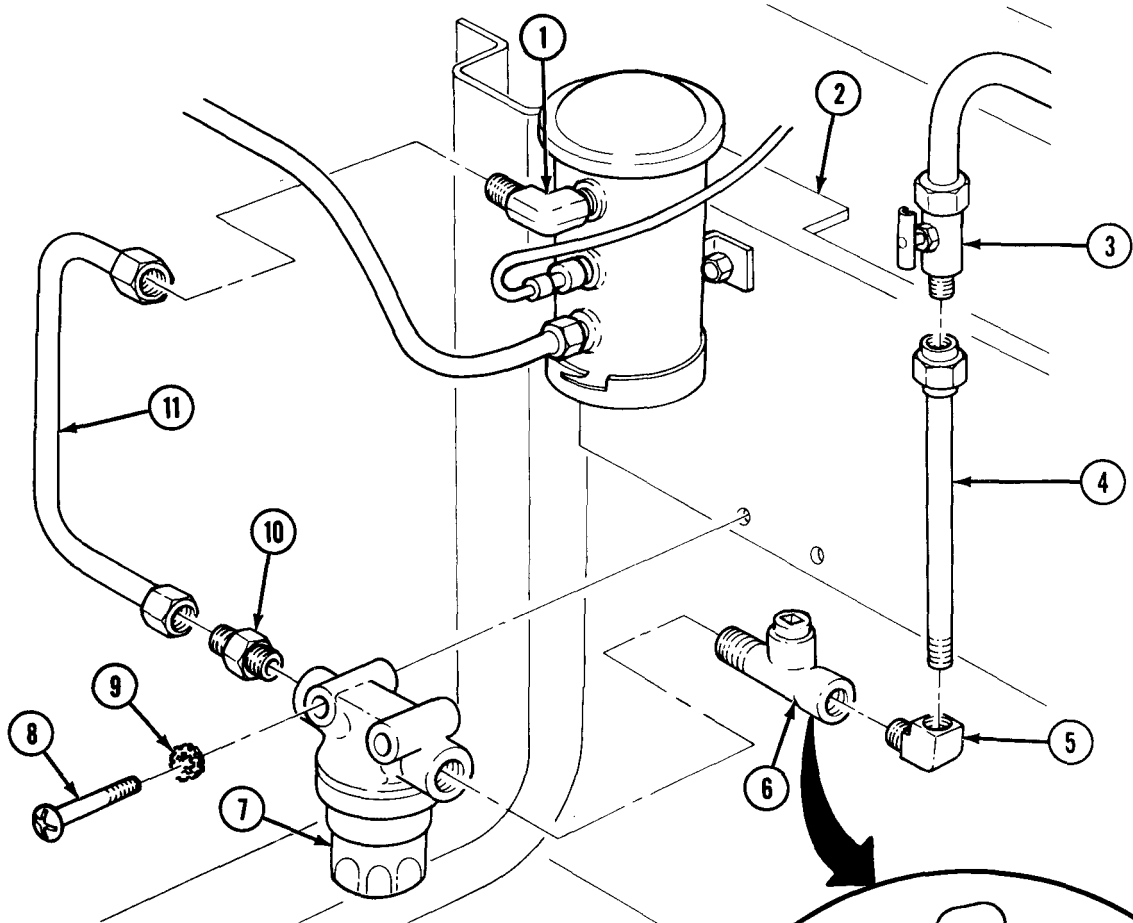

W/O ENGINE COOLANT

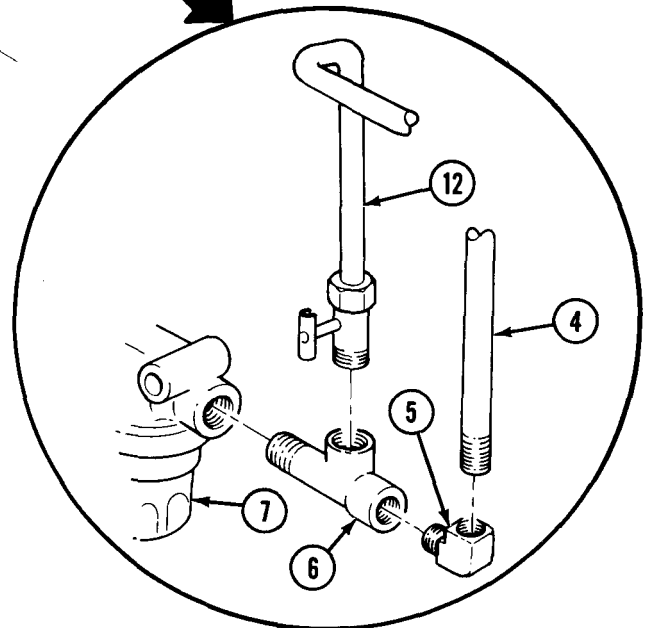

W/ENGINE COOLANT

## 14-6. EXHAUST TUBE REPLACEMENT

This task covers:

### a. Removal

### b. Installation

#### INITIAL SETUP:

##### APPLICABLE MODELS

All

##### EQUIPMENT CONDITION

Parking brake set (TM 9-2320-361-10).

##### MATERIALS/PARTS

Cotter pin  
Locknut

##### GENERAL SAFETY INSTRUCTIONS

Do not touch hot exhaust system components with bare hands.

##### REFERENCES (TM)

TM 9-2320-361-10  
TM 9-2320-361-20P

### a. Removal

#### WARNING

Do not touch hot exhaust system components with bare hands; injury to personnel will result.

1. Remove cotter pin (2) and exhaust tube (7) from personnel heater elbow (1). Discard cotter pin (2).
2. Remove two nuts (5), screws (3), clamps (4), and exhaust tube (7) from left front fender (6).
3. Remove locknut (8), screw (10), clamp (9), and exhaust tube (7) from splash shield (11). Discard locknut (8).
4. Remove exhaust tube (7) from vehicle.

### b. Installation

1. Install exhaust tube (7) on personnel heater elbow (1) with new cotter pin (2) through elbow (1) and tube (7).
2. Install exhaust tube (7) on left front fender (6) with two clamps (4), screws (3), and nuts (5).
3. Install exhaust tube (7) to splash shield (11) with clamp (9), screw (10), and new locknut (8).

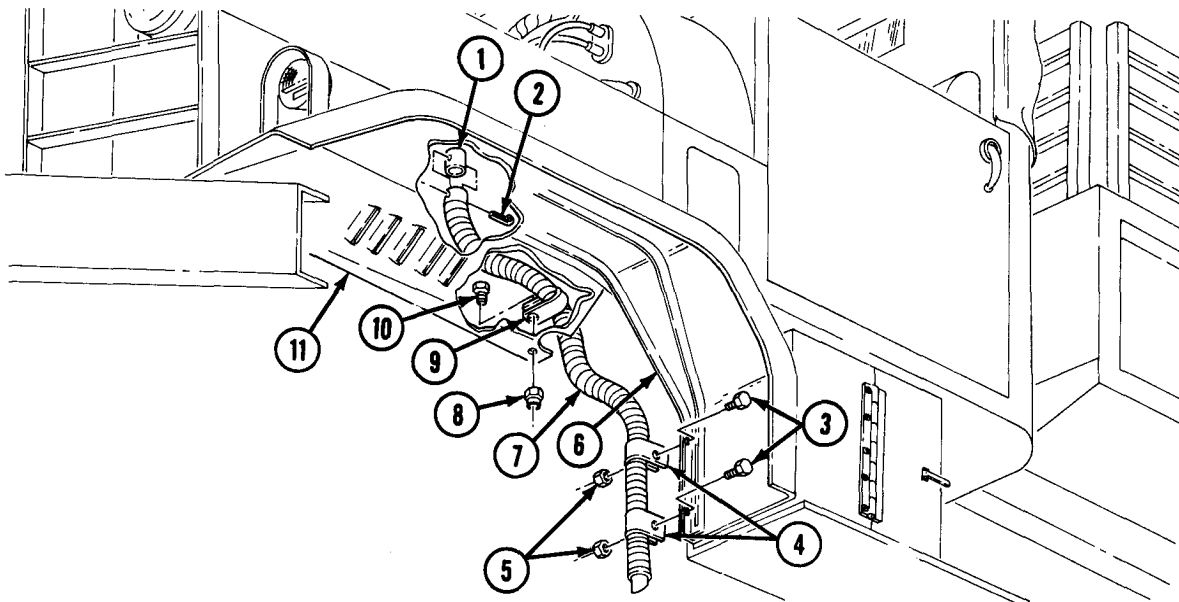

## 14-7. OIL PAN SHROUD AND EXHAUST TUBE REPLACEMENT

This task covers:

### a. Removal

### b. Installation

#### INITIAL SETUP:

#### APPLICABLE MODELS

All

#### MATERIALS/PARTS

Three cotter pins  
Four lockwashers  
Locknut

#### REFERENCES (TM)

TM 9-2320-361-10  
TM 9-2320-361-20P

#### EQUIPMENT CONDITION

Parking brake set (TM 9-2320-361-10).

#### GENERAL SAFETY INSTRUCTIONS

Do not touch hot exhaust system components with bare hands.

### a. Removal

#### WARNING

Do not touch hot exhaust system components with bare hands; injury to personnel will result.

1. Remove cotter pin (9) and exhaust tube (10) from oil pan shroud (6). Discard cotter pin (9).
2. Remove two cotter pins (12), elbow (13), and exhaust tube (10) from heater (14). Discard cotter pins (12).
3. Remove locknut (1), screw (3), clamp (2), and exhaust tube (10) from splash shield (4). Discard locknut(1).
4. Remove exhaust tube (10) from vehicle.
5. Remove four screws (8), lockwashers (7), and oil pan shroud (6) from engine oil pan (5). Discard lockwashers (7).

### b. Installation

1. Install oil pan shroud (6) on engine oil pan (5) with four new lockwashers (7) and screws (8).
2. Install exhaust tube (10) on oil pan shroud (6) with new cotter pin (9).
3. Insert exhaust tube (10) through hole (11) in toolbox.
4. Install elbow (13) and exhaust tube (10) on heater (14) with two new cotter pins (12).
5. Install exhaust tube (10) on splash shield (4) with clamp (2), screw (3), and new locknut (1).

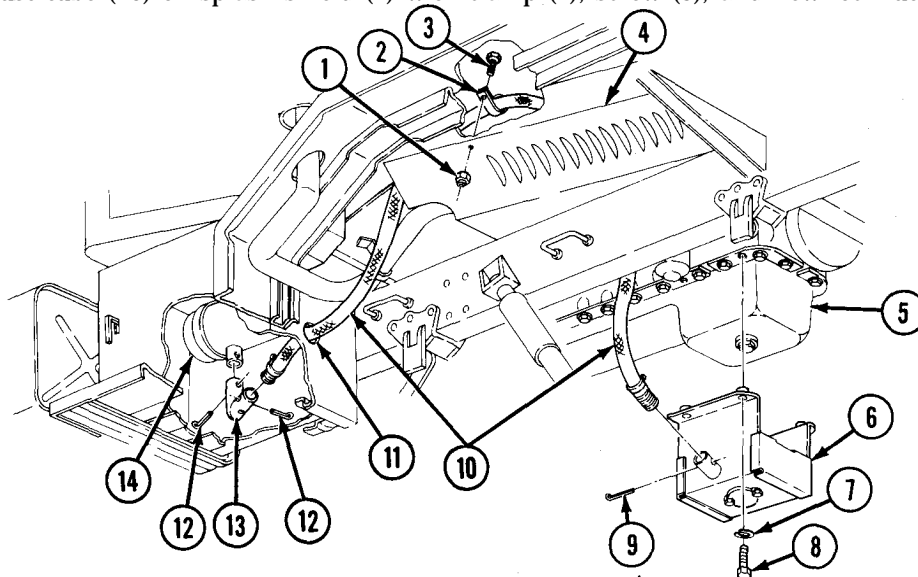

**14-8. ENGINE COOLANT HEATER REPLACEMENT**

This task covers:

**a. Removal**

**b. Installation**

**INITIAL SETUP:**

APPLICABLE MODELS

All

MATERIALS/PARTS

Cotter pin

REFERENCES (TM)

TM 9-2320-361-10

TM 9-2320-361-20P

EQUIPMENT CONDITION

- Parking brake set (TM 9-2320-361-10).
- Battery ground cable disconnected (para. 4-48).

**a. Removal**

**NOTE**

- Prior to removal, close fuel shutoff, engine oil, and water manifold valves.
- Have drainage container ready to catch coolant.

1. Disconnect harness (3) from heater (4).
2. Disconnect fuel line (1) from elbow (14).
3. Remove clamp (13) and hose (12) from elbow (11).
4. Remove cotter pin (10) and elbow (8) from heater (4). Discard cotter pin (10).
5. Remove clamp (6) and hose (5) from elbow (7).
6. Remove two clamps (9) and heater (4) from saddle brackets (2).

**b. Installation**

1. Install heater (4) on saddle brackets (2) with two clamps (9).
2. Install hose (5) on elbow (7) with clamp (6).
3. Install elbow (8) on heater (4) with new cotter pin (10).
4. Install hose (12) on elbow (11) with clamp (13).
5. Connect fuel line (1) to elbow (14).
6. Connect harness (3) to heater (4).

**14-8. ENGINE COOLANT HEATER REPLACEMENT (Contd)**

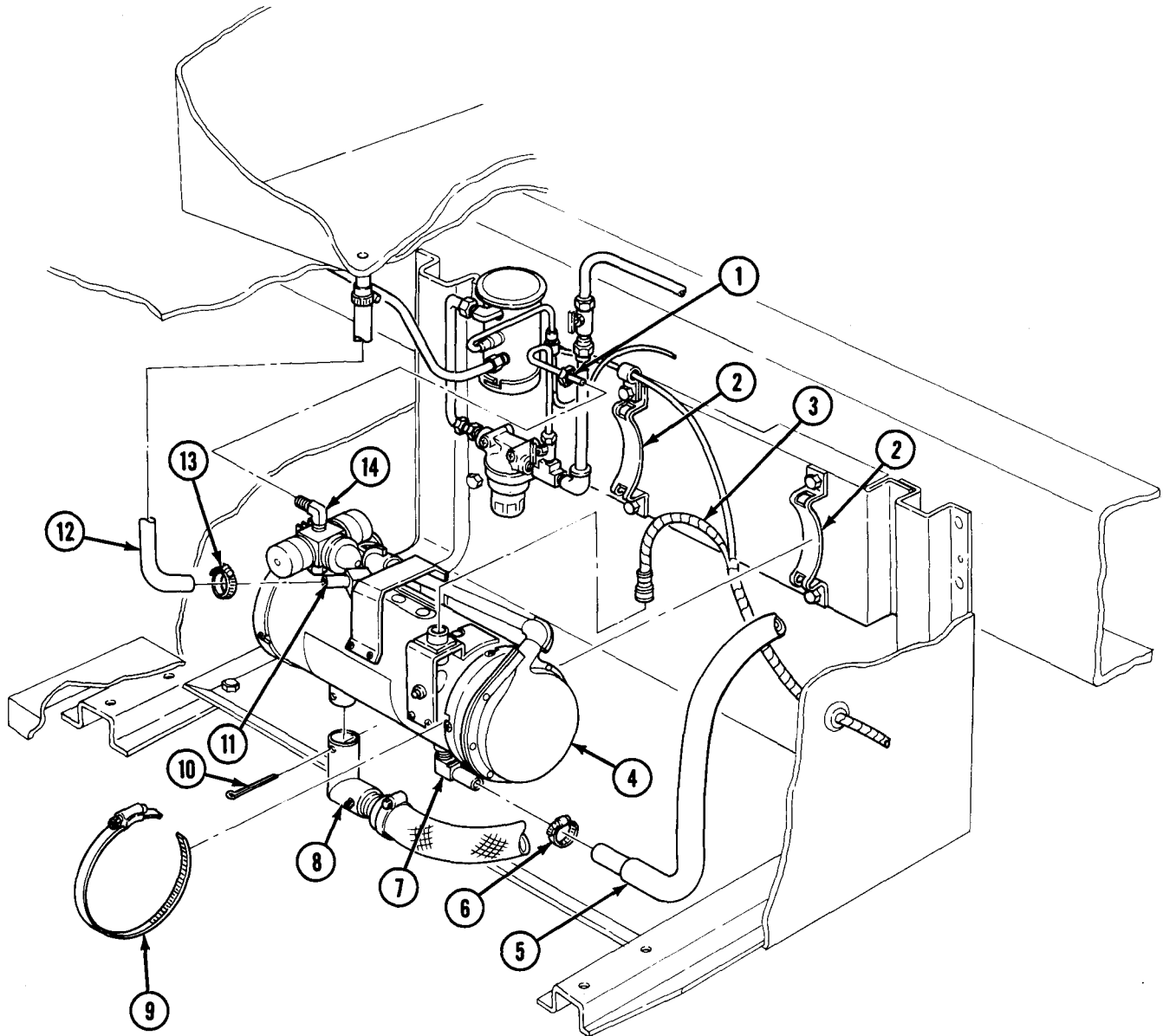

FOLLOW-ON TASK: Connect battery ground cable (para. 4-48).



**14-9. ENGINE COOLANT HEATER HARNESS REPLACEMENT**

This task covers:

**a. Removal**

**b. Installation**

**INITIAL SETUP:**

APPLICABLE MODELS

All

MATERIALS/PARTS

Two lockwashers

REFERENCES (TM)

TM 9-2320-361-10

TM 9-2320-361-20P

EQUIPMENT CONDITION

- Parking brake set (TM 9-2320-361-10).
- Disconnect battery ground cable (para. 4-48).

**a. Removal**

**CAUTION**

Use care when routing harness. Snagging may result, and forceful pulling will cause damage to harness.

1. Remove screw (10), lockwasher (11), clamp (12), and ground lead (13) from right side of fuel pump (16). Discard lockwasher (11).
2. Remove screw (8), lockwasher (9), clamp (7), and ground lead (13) from saddle bracket (17). Discard lockwasher (9).
3. Disconnect harness (6) from heater (14).
4. Remove grommet (18) and pull harness (6) from battery box (15).
5. From under instrument panel (2), disconnect harness lead (3) from diode box wire (1).
6. Disconnect harness (6) from heater control box (19).
7. Remove grommet (4) and pull harness (6) from firewall (5).
8. Remove harness (6) from vehicle.

**b. Installation**

1. Insert harness (6) through firewall (5).
2. From under instrument panel (2), connect harness (6) to heater control box (19).
3. Connect harness lead (3) to diode box wire (1).
4. Insert harness (6) through battery box (15) and connect to heater (14).
5. Install ground lead (13), clamp (12), new lockwasher (11), and screw (10) on the right side of fuel pump (16).
6. Install ground lead (13) saddle bracket (17) with clamp (7), new lockwasher (9), and screw (8).
7. Install two grommets (4) and (18) on firewall (5) and toolbox (15).

14-9. ENGINE COOLANT HEATER HARNESS REPLACEMENT (Contd)

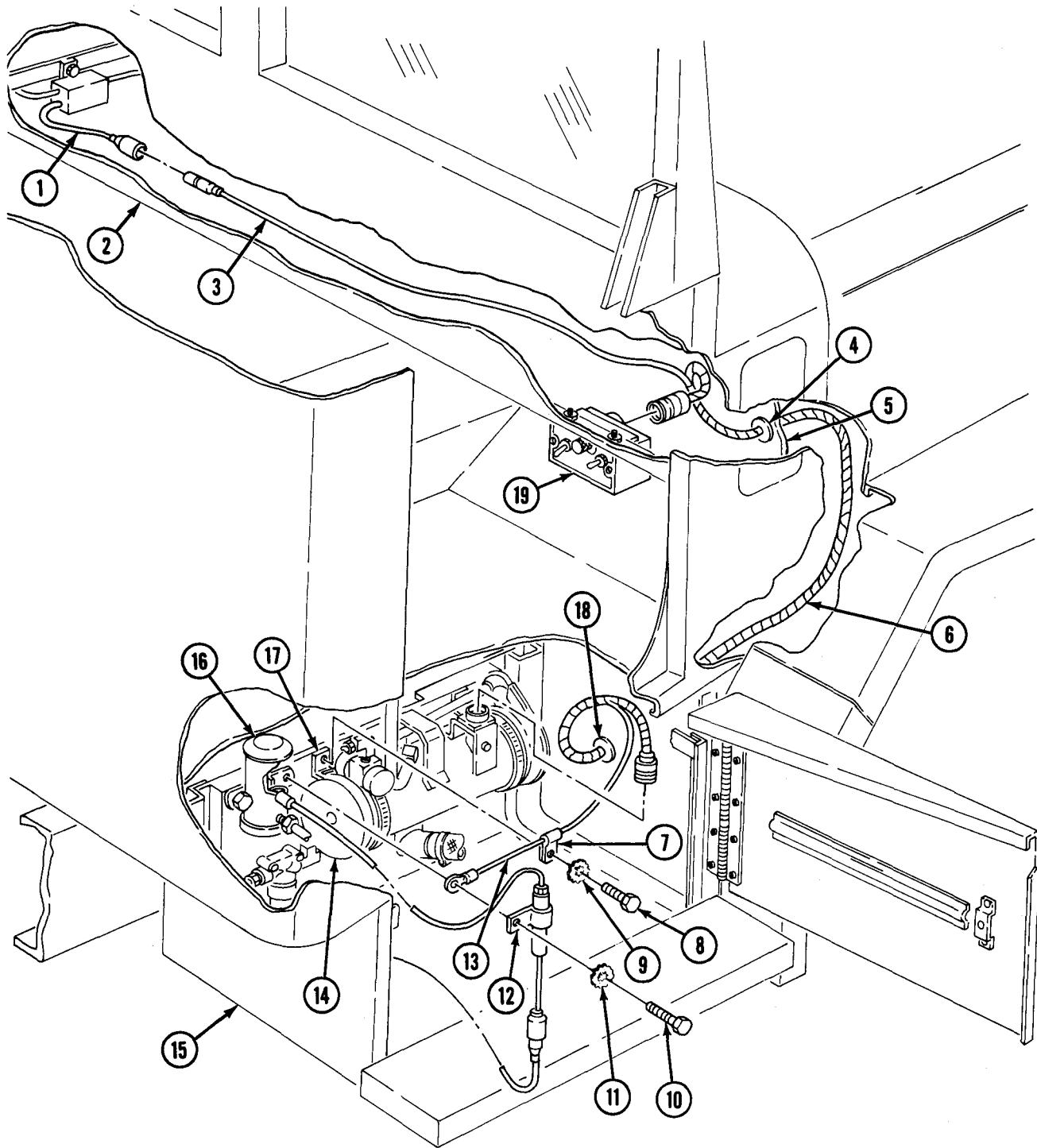

FOLLOW-ON TASK: Connect battery ground cable (para. 4-48).

**14-10. THERMAL BARRIER INSULATION REPLACEMENT**

This task covers:

**a. Removal**

**b. Installation**

**INITIAL SETUP:**

**APPLICABLE MODELS**

All

**MATERIALS/PARTS**

Adhesive sealant (Appendix C, Item 4)

Methylethylketone (Appendix C, Item 16)

**REFERENCES (TM)**

TM 9-2320-361-10

TM 9-2320-361-20P

**EQUIPMENT CONDITION**

- Parking brake set (TM 9-2320-361-10).
- Driver's seat removed (para. 11-28).
- Companion seat removed (para. 11-26).

**NOTE**

All thermal barrier insulation is removed the same way. This procedure covers replacement of left rear insulation panel only.

**a. Removal**

1. Pull panel (2) away from cab interior (1). Discard panel (2) if irreparable damage occurs when removing.
2. Clean all remaining insulating material and adhesive from contact surface areas.

**b. Installation**

**CAUTION**

Once panel is coated with methylethylketone and put in place, it cannot be moved. Be careful not to place panel in the wrong position.

**NOTE**

Make all necessary cutouts and slits in panels before installation. Shiny side of panel must face outward.

1. Place panel (2) on cab (1) to check for fit.
2. Remove panel (2) and coat contact areas with methylethylketone.
3. Install panel (2) on cab (1) and press firmly into place.

**NOTE**

If additional adhesive sealant is required, perform steps 4 and 5.

4. Remove panel (2) and coat contact areas with adhesive sealant.
5. Install panel (2) on cab (1) and press firmly into place.

**14-10. THERMAL BARRIER INSULATION REPLACEMENT (Contd)**

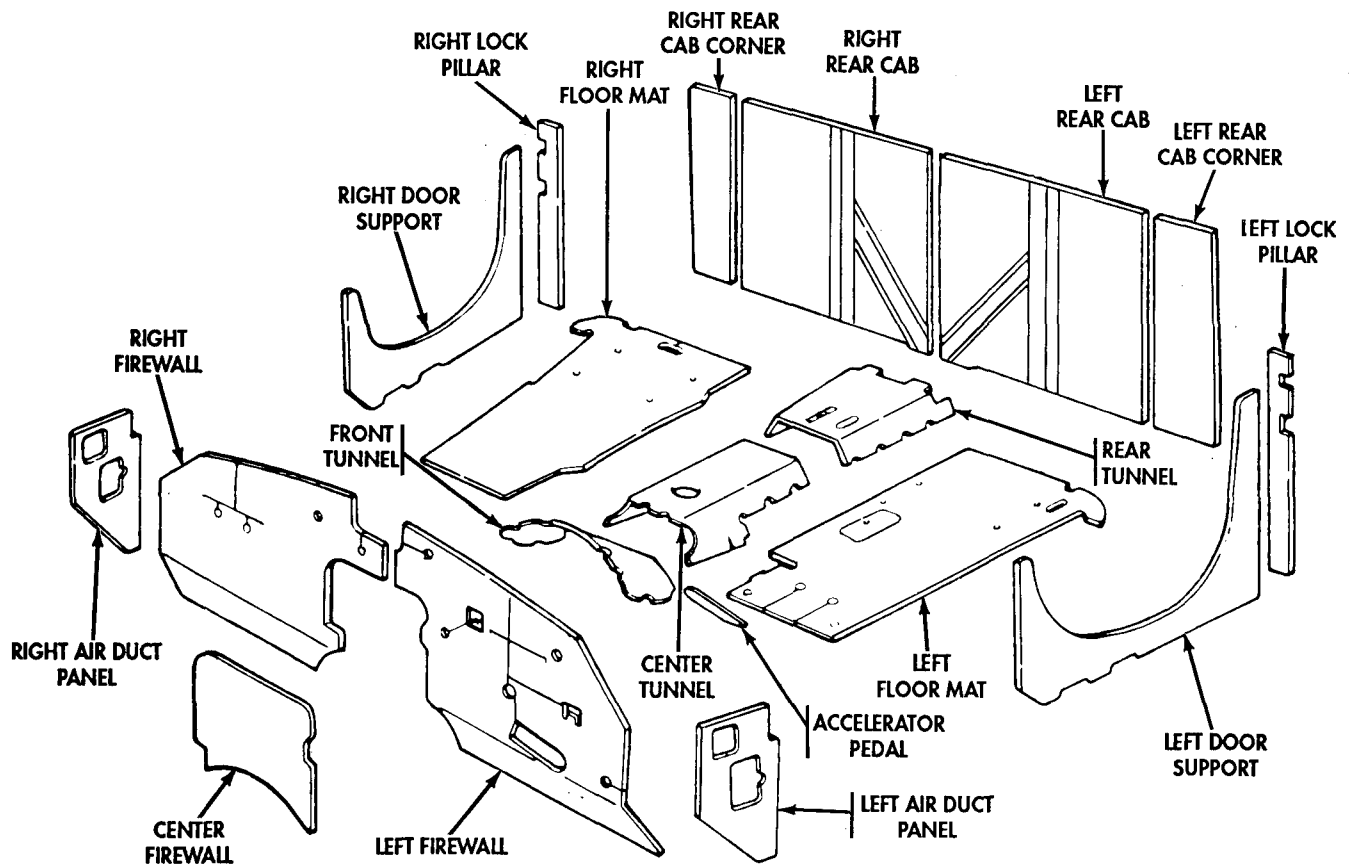
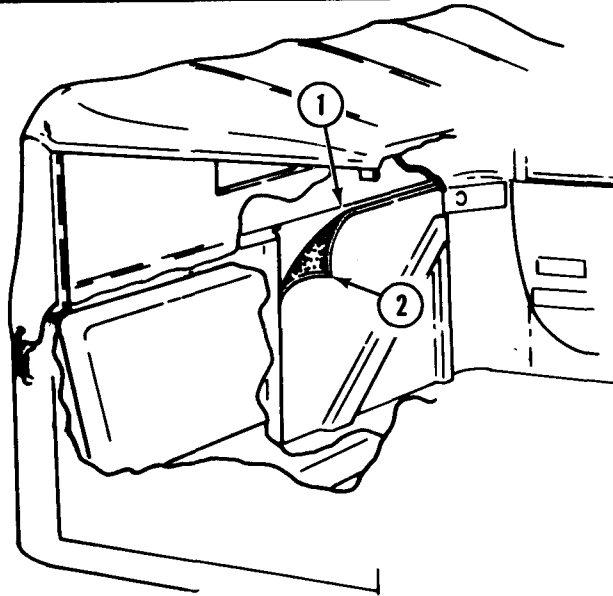

- FOLLOW-ON TASKS:
- Install driver's seat (para. 11-28).
  - Install companion seat (para. 11-26).

**14-11. BATTERY BOX HEATER PAD REPLACEMENT**

This task covers:

**a. Removal**

**b. Installation**

INITIAL SETUP:

APPLICABLE MODELS

All

REFERENCES (TM)

TM 9-2320-361-10

TM 9-2320-361-20P

EQUIPMENT CONDITION

- Parking brake set (TM 9-2320-361-10).
- Companion seat removed (para. 11-26).
- Batteries removed (para. 4-49).

**a. Removal**

**NOTE**

- Prior to removal, close water manifold valve.
- Have drainage container ready to catch coolant.

1. Loosen two clamps (3) and remove exhaust inlet hose (4) and outlet hose (2) from heater pad (1).
2. Remove heater pad (1) from battery box (5).

**b. Installation**

1. Install heater pad (1) in battery box (5).
2. Install exhaust inlet hose (4) and outlet hose (2) on heater pad (1), and tighten clamps (3).

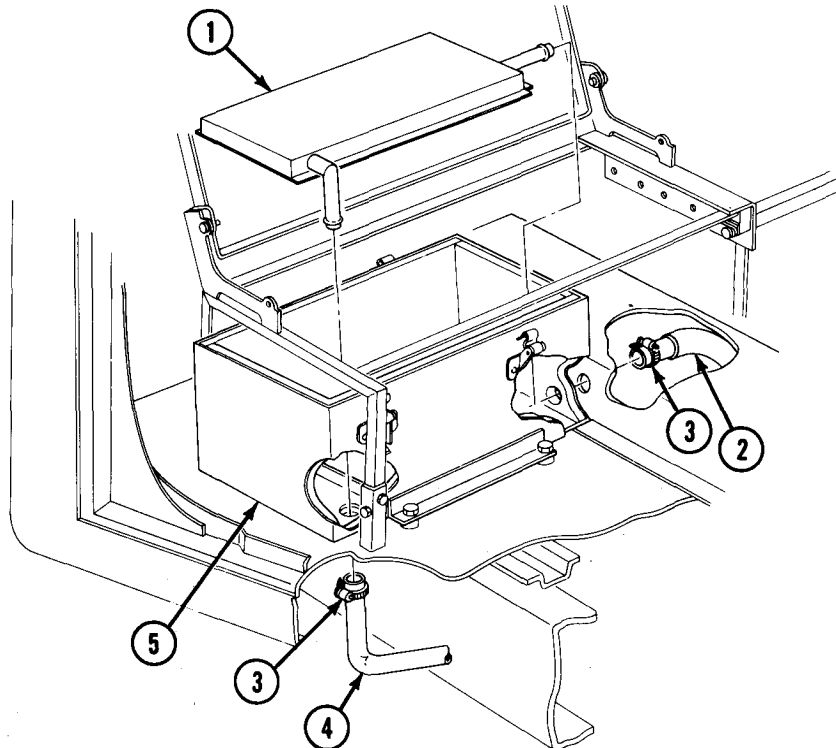

- FOLLOW-ON TASKS:
- Install batteries (para. 4-49).
  - Install companion seat (para. 11-26).

## 14-12. TRANSMISSION GEARSHIFT AND TRANSFER CASE LEVER COVER REPLACEMENT

This task covers:

### a. Removal

### b. Installation

INITIAL SETUP:

#### APPLICABLE MODELS

All

#### EQUIPMENT CONDITION

Parking brake set (TM 9-2320-361-10).

#### REFERENCES (TM)

TM 9-2320-361-10

TM 9-2320-361-20P

### a. Removal

1. Remove gearshift knob (1) from gearshift lever (5).
2. Remove four screws (2) and gearshift cover (3) from intermediate tunnel (4). Slide gearshift cover (3) from gearshift lever (5).
3. Remove four screws (8) and transfer case lever cover (7) from intermediate tunnel (4) and transfer case lever (6). Slide transfer case lever cover (7) from transfer case lever (6).

### b. Installation

1. Place transfer case lever cover (7) over transfer case lever (6) and install on intermediate tunnel (4) with four screws (8).
2. Place gearshift cover (3) over gearshift lever (5) and install on intermediate tunnel (4) with four screws (2).
3. Install gearshift knob (1) on gearshift lever (5).

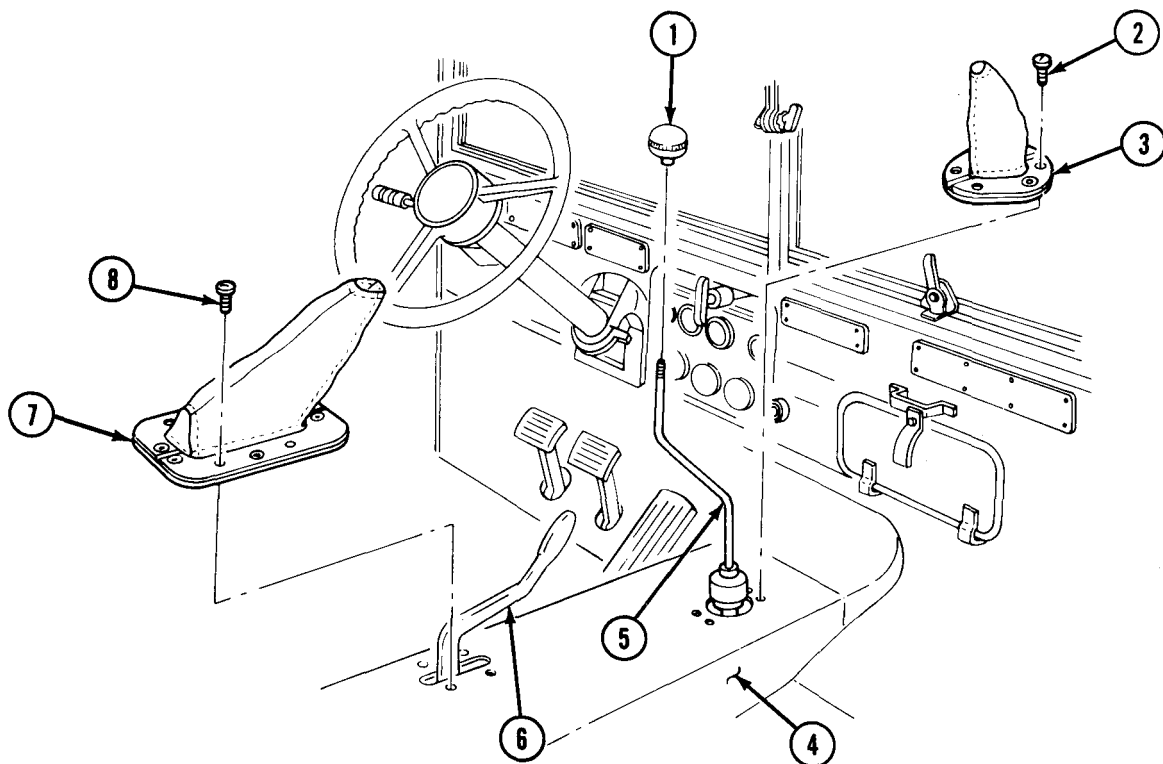

## 14-13. HOOD AND RADIATOR COVER REPLACEMENT

This task covers:

### a. Removal

### b. Installation

INITIAL SETUP:

#### APPLICABLE MODELS

All

#### REFERENCES (TM)

TM 9-2320-361-10

TM 9-2320-361-20P

#### EQUIPMENT CONDITION

- Parking brake set (TM 9-2320-361-10).
- Air cleaner removed (para. 3-15).

### a. Removal

1. Remove three retaining springs (7) from front fender (12) and side panel loops (11). Repeat for the opposite side.
2. Unfasten buckles (3) and pull straps (1) through loops (2).
3. Unfasten buckle (6) and pull strap (5) through loops (4). Repeat for the opposite side.
4. Remove radiator cover (8) from brush guard (9).
5. Unfasten buckles (15) and pull straps (14) through loops (13). Repeat for the opposite side.
6. Remove hood cover (16) from hood (10).
7. Unfasten buckles (20) and pull straps (19) through loops (18).
8. Remove side panel cover (17) from side panel (21). Repeat for the opposite side.

### b. Installation

1. Install side panel cover (17) on side panel (21) and insert loops (18) through side panel cover (17).
2. Thread straps (19) through loops (18) and fasten buckles (20). Repeat for the opposite side.
3. Install hood cover (16) on hood (10) and insert loops (13) through hood cover (16).
4. Thread straps (14) through loops (13) and fasten buckles (15). Repeat for the opposite side.
5. Install radiator cover (8) on brush guard (9) and insert loops (2) and (4) through radiator cover (8).
6. Thread straps (1) through loops (2) and fasten buckles (3).
7. Thread strap (5) through loops (4) and fasten buckle (6). Repeat for the opposite side.
8. Install three retaining springs (7) on front fender (12) and side panel loops (11). Repeat for the opposite side.

14-13. HOOD AND RADIATOR COVER REPLACEMENT (Contd)

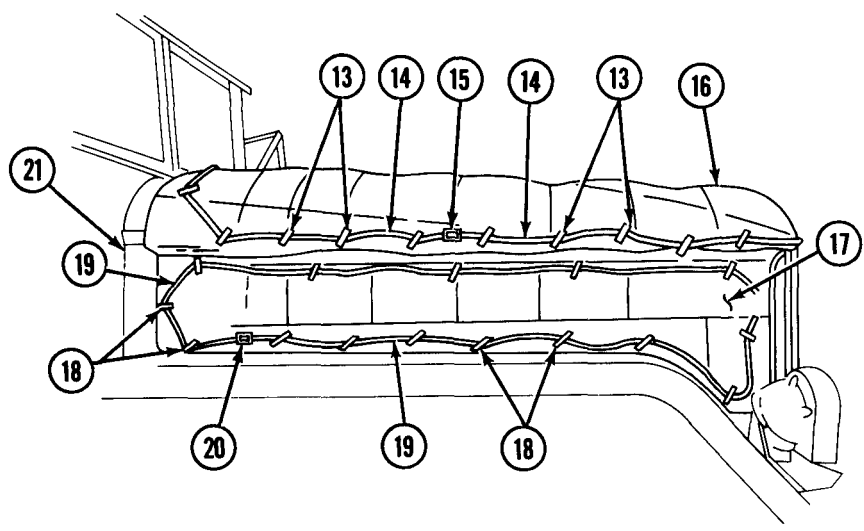
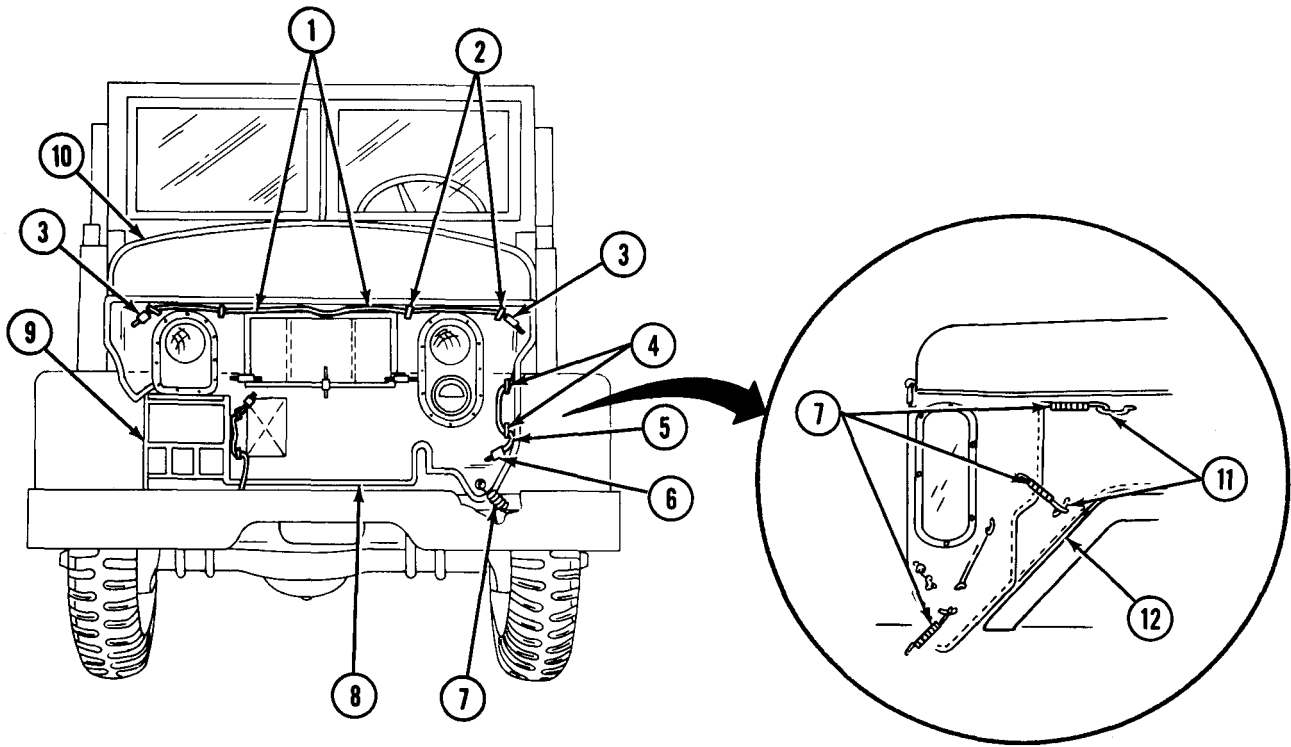

FOLLOW-ON TASK: Install air cleaner (para. 3-15).



**14-14. HARDTOP MAINTENANCE**

This task covers:

- a. Removal
- b. Disassembly

- c. Assembly
- d. Installation

**INITIAL SETUP:**

APPLICABLE MODELS

All

MATERIALS/PARTS

Ten lockwashers  
 Thirty locknuts

PERSONNEL REQUIRED

Two

REFERENCES (TM)

TM 9-2320-361-10  
 TM 9-2320-361-20P

EQUIPMENT CONDITION

Parking brake set (TM 9-2320-361-10).

**a. Removal**

1. Remove two screws (1) and lockwashers (2) from each side of roof (3) and windshield frame (13). Discard two lockwashers (2).
2. Remove capscrew (11), washer (12), and locknut (4) from each side of roof (3) and windshield frame (13). Discard locknut (4).
3. Remove fourteen screws (10), locknuts (5), and washers (6) and (9) from roof (3). Discard locknuts (5).

**NOTE**

Assistant will help with step 4.

4. Remove roof (3) and seal (7).
5. Remove two screws (19) and retainers (18) from back panel (8).
6. Remove fourteen locknuts (20), screws (15), and washers (16) from back panel (8) and cab (14). Discard locknuts (20).
7. Remove back panel (8) and seal (17) from cab (14).

**b. Disassembly**

1. Remove eight nuts (21), lockwashers (22), screws (25), and frame cap (24) from back panel (8). Discard lockwashers (22).
2. Remove fourteen nuts (28), washers (27), screws (26), and rear window (23) from back panel (8).

**c. Assembly**

1. Install rear window (23) on back panel (8) with fourteen screws (26), washers (27), and nuts (28).
2. Install frame cap (24) on rear window (23) and back panel (8) with eight screws (25), new lockwashers (22), and nuts (21).

## 14-14. HARDTOP MAINTENANCE (Contd)

### d. Installation

#### NOTE

Do not tighten any screws or nuts until kit is fully installed.

1. Install seal (17) to back panel (8) with two retainers (18) and screws (19).
2. Install back panel (8) to cab (14) and aline holes.
3. Install fourteen washers (16), screws (15), and new locknuts (20) on back panel (8) and cab (14)

#### NOTE

Assistant will help with step 4.

4. Place seal (7) on back panel (8). Install roof (3) on back panel (8) and aline holes.
5. Install fourteen washers (6), screws (10), washers (9), and new locknuts (5) on back panel (8) and roof (3). Do not tighten.
6. Install washer (12), capscrew (11), and new locknut (4) on each side of roof (3) and windshield frame (13).
7. Close cab windows and inspect all panels for alinement and seating. Adjust panels as required.
8. Tighten capscrews (11) and fourteen screws (10).
9. Install two screws (1) and new lockwashers (2) on roof (3) and windshield frame (13).

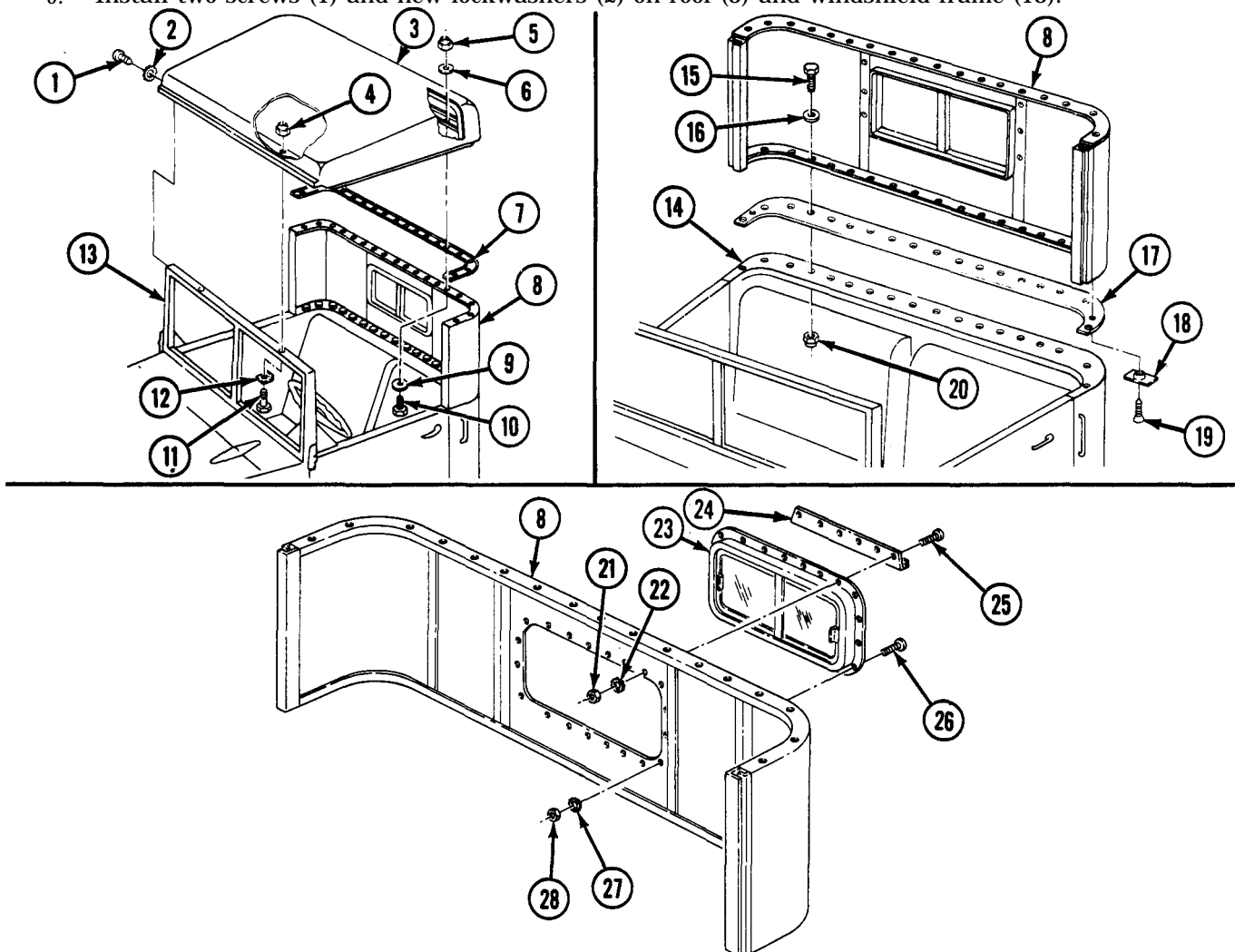

## 14-15. ALCOHOL EVAPORATOR REPLACEMENT

This task covers:

### a. Removal

### b. Installation

#### INITIAL SETUP:

##### APPLICABLE MODELS

All

##### MATERIALS/PARTS

Three locknuts

##### REFERENCES (TM)

TM 9-2320-361-10

TM 9-2320-361-20P

##### EQUIPMENT CONDITION

- Parking brake set (TM 9-2320-361-10).
- Hood raised and secured (TM 9-2320-361-10).

##### GENERAL SAFETY INSTRUCTIONS

Diesel fuel is flammable. Do not perform this procedure near open flames.

#### WARNING

Do not perform this procedure while smoking or within 50 feet of sparks or open flame. Fuel is flammable and can explode easily, causing injury or death to personnel and damage to equipment.

#### a. Removal

1. Remove jar (9) and O-ring (8) from evaporator body (7).
2. Disconnect tube (5) from compressor elbow (13) and adapter (6).
3. Remove three locknuts (11), screws (12), and evaporator body (7) from bracket (1). Discard locknuts (11).
4. Disconnect adapter (6) from evaporator body (7).
5. Disconnect tube (3) from outlet manifold (2).
6. Remove two screws (4), outlet manifold (2), and bracket (1) from compressor (10).

#### b. Installation

1. Install bracket (1) and outlet manifold (2) on compressor (10) with two screws (4).
2. Connect tube (3) to outlet manifold (2).
3. Install adapter (6) on evaporator body (7).
4. Install evaporator body (7) on bracket (1) with three screws (12) and new locknuts (11).
5. Connect tube (5) to compressor elbow (13) and adapter (6).
6. Install O-ring (8) and jar (9) on evaporator body (7).

14-15. ALCOHOL EVAPORATOR REPLACEMENT (Contd)

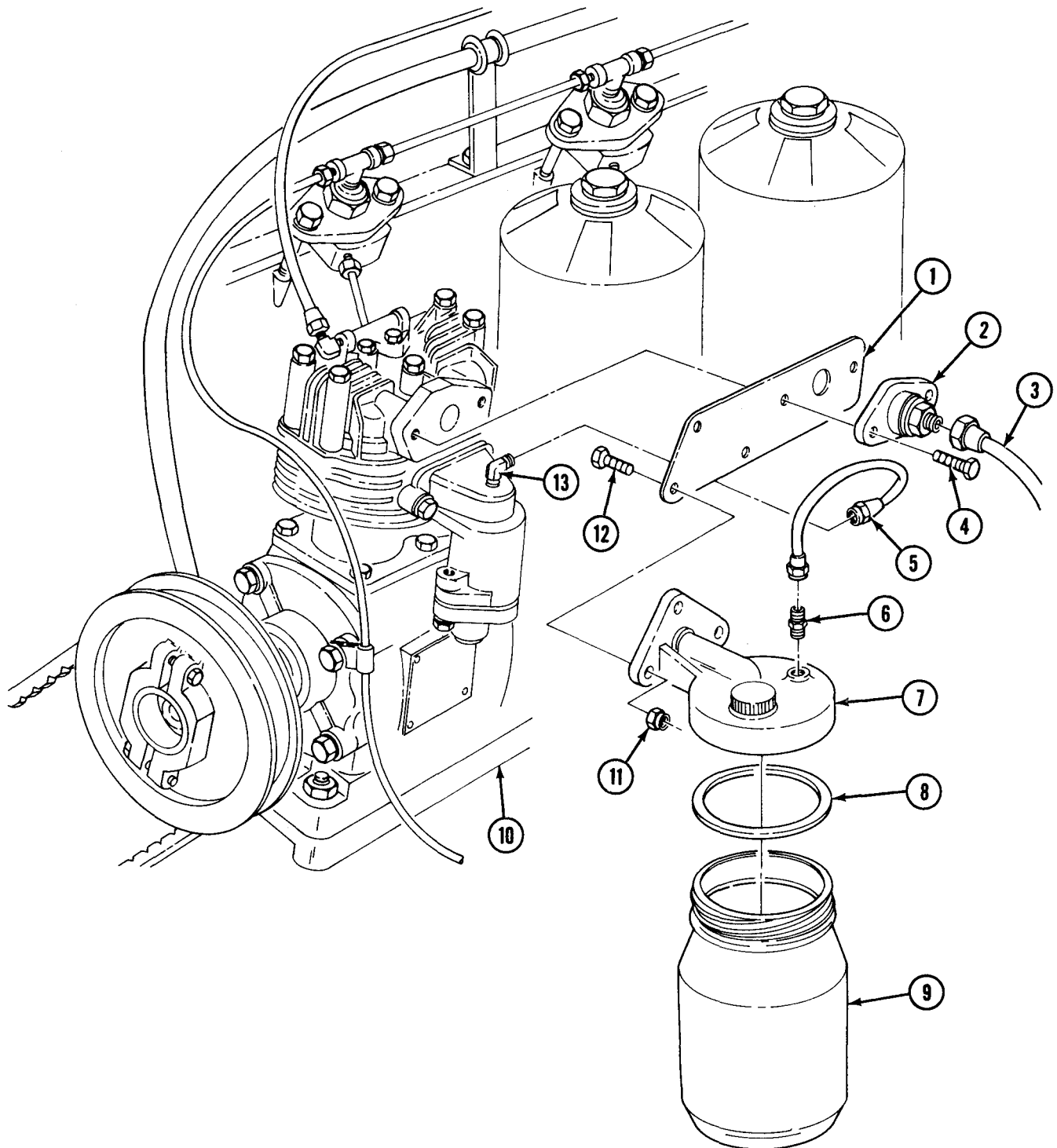

FOLLOW-ON TASK: Fill evaporator jar, start engine (TM 9-2320-361-10), and check alcohol evaporator operation.

## 14-16. SLAVE RECEPTACLE REPLACEMENT

This task covers:

### **a. Removal**

### **b. Installation**

#### INITIAL SETUP:

##### APPLICABLE MODELS

All

##### MATERIALS/PARTS

Six lockwashers  
Locknut

##### REFERENCES (TM)

TM 9-2320-361-10  
TM 9-2320-361-20P

##### EQUIPMENT CONDITION

- Parking brake set (TM 9-2320-361-10).
- Battery ground cable disconnected (para. 4-48).

##### GENERAL SAFETY INSTRUCTIONS

Battery ground cables must be disconnected before removing slave receptacle.

#### WARNING

Do not remove slave receptacle before disconnecting battery ground cables. If energized battery cables contact cab, a direct short will result and may cause injury to personnel.

### **a. Removal**

1. Remove locknut (10), screw (13), ground cable (3), and two lockwashers (12) from rear battery box support hanger (11). Discard lockwashers (12) and locknut (10).
2. Remove nut (9), screw (5), and positive cables (6) and (8) from positive battery terminal (7).
3. Remove four nuts (18), lockwashers (19), and screws (20) from slave receptacle (1). Discard lockwashers (19).
4. Remove two screws (4), clamps (2), ground cable (3), and positive cable (6) from back cab panel support (16).
5. Remove two grommets (15) from cab floor (14) and pull receptacle from cab (17).

### **b. Installation**

1. Install slave receptacle (1) through cab (17) and cab floor (14).
2. Install two grommets (15) on ground cable (3) and positive cable (6) and install on cab floor (14).
3. Install slave receptacle (1) on cab (17) with four screws (20), new lockwashers (19), and nuts (18).
4. Install positive cables (6) and (8) on positive battery terminal (7) with screw (5) and nut (9).
5. Install ground cable (3) on rear battery box support hanger (11) with screw (13), two new lockwashers (12), and new locknut (10).
6. Install ground cable (3) and positive cable (6) on back cab panel support (16) with two clamps (2) and screws (4).

14-16. SLAVE RECEPTACLE REPLACEMENT (Contd)

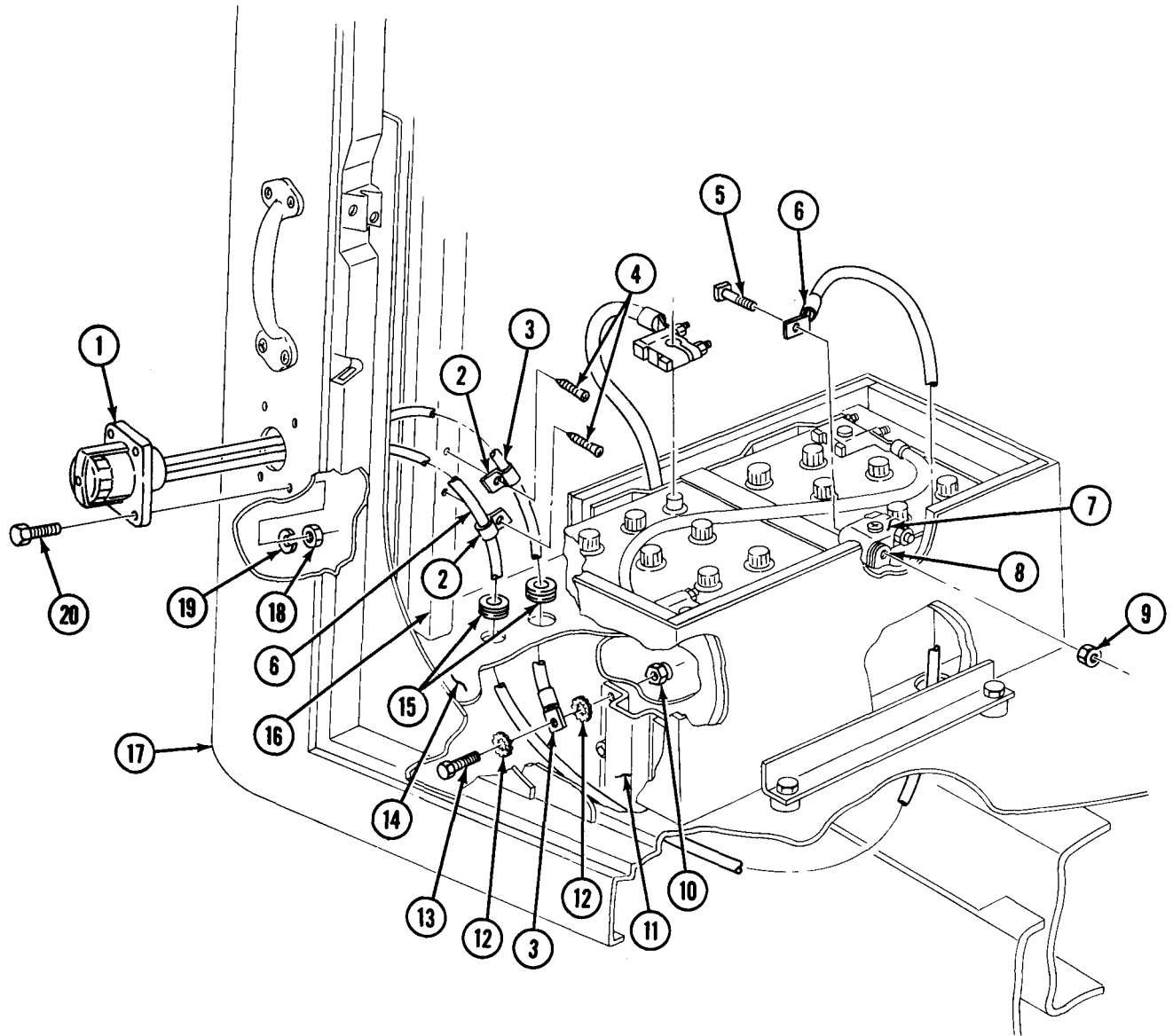

FOLLOW-ON TASK: Connect battery ground cable (para. 4-48).

**14-17. CARGO BODY PERSONNEL HEATER REPLACEMENT**

This task covers:

**a. Removal**

**b. Installation**

**INITIAL SETUP:**

**APPLICABLE MODELS**

M35A2, M35A2C, M36A2

**MATERIALS/PARTS**

Four lockwashers  
Gasket

**REFERENCES (TM)**

TM 9-2320-361-10  
TM 9-2320-361-20P

**EQUIPMENT CONDITION**

- Parking brake set (TM 9-2320-361-10).
- Battery ground cable disconnected (para. 4-48).

**a. Removal**

1. Close fuel shutoff valve (20).
2. Release four latches (1) and remove cover (2) from four plate assemblies (19).
3. Disconnect wiring harness (5) from heater (4).
4. Disconnect fuel line (11) from heater elbow (3).
5. Remove clamp (17) and duct (18) from inlet adapter (16).
6. Remove two clamps (9) and heater (4) from mounting bracket (10).
7. Remove inlet adapter (16) from heater (4).
8. Remove four screws (8), lockwashers (7), and outlet adapter (6) from heater (4). Discard lockwashers (7).
9. Remove extension (12), gasket (13), and spacer (14) from heater exhaust (15). Discard gasket (13).

**b. Installation**

1. Install spacer (14), new gasket (13), and extension (12) on heater exhaust (15).
2. Install outlet adapter (6) on heater (4) with four new lockwashers (7) and screws (8).
3. Install inlet adapter (16) on heater (4).
4. Install heater (4) on mounting bracket (10) with two clamps (9).
5. Install duct (18) on inlet adapter (16) with clamp (17).
6. Connect fuel line (11) to heater elbow (3).
7. Connect wiring harness (5) to heater (4).
8. Install cover (2) on four plate assemblies (19) and close four latches (1).
9. Open fuel shutoff valve (20).

## 14-17. CARGO BODY PERSONNEL HEATER REPLACEMENT (Contd)

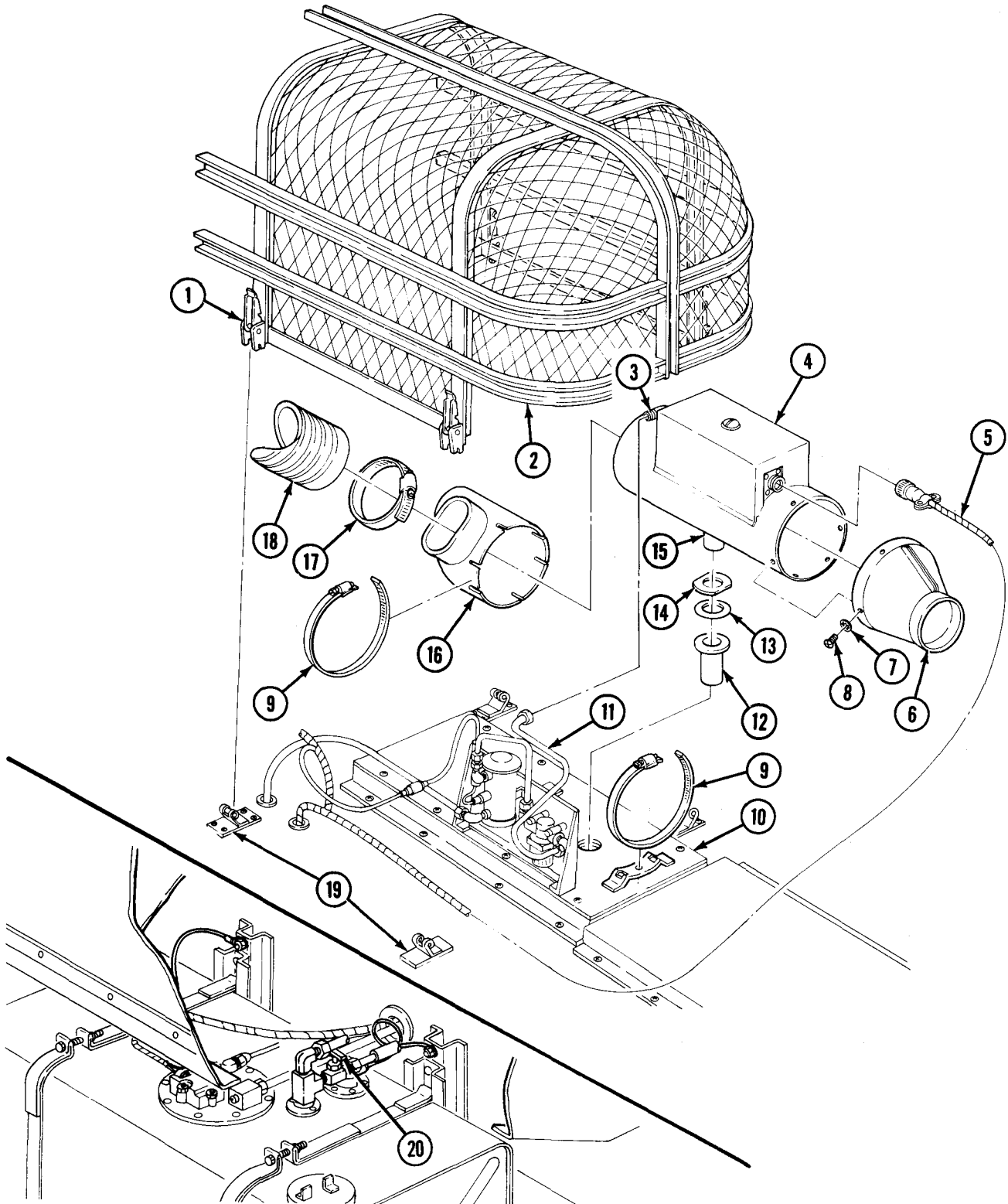

FOLLOW-ON TASKS: • Connect battery ground cable (para. 4-48).  
 • Start personnel heater and check operation (TM 9-2320-361-10).



**14-18. CARGO BODY PERSONNEL HEATER MOUNTING BRACKET REPLACEMENT**

This task covers:

**a. Removal**

**b. Installation**

**INITIAL SETUP:**

**APPLICABLE MODELS**

M35A2, M35A2C, M36A2

**REFERENCES (TM)**

TM 9-2320-361-10

TM 9-2320-361-20P

**EQUIPMENT CONDITION**

- Parking brake set (TM 9-2320-361-10).
- Heater removed (para. 14-17).
- Heater fuel pump removed (para. 14-19).
- Heater fuel filter removed (para. 14-20).

**a. Removal**

1. Remove eight screws (4) and deflector bracket (5) from cargo body floor (7).
2. Remove eight screws (3) and mounting support (2) from mounting plate (10).
3. Remove eight screws (1), mounting plate (10), and gasket (6) from cargo body floor (7).
4. Remove sixteen screws (9) and four plates (8) from cargo body floor (7).

**b. Installation**

1. Install four plates (8) on cargo body floor (7) with sixteen screws (9).
2. Install gasket (6) and mounting plate (10) on cargo body floor (7) with eight screws (1).
3. Install mounting support (2) on mounting plate (10) with eight screws (3).
4. Install deflector bracket (5) on cargo body floor (7) with eight screws (4).

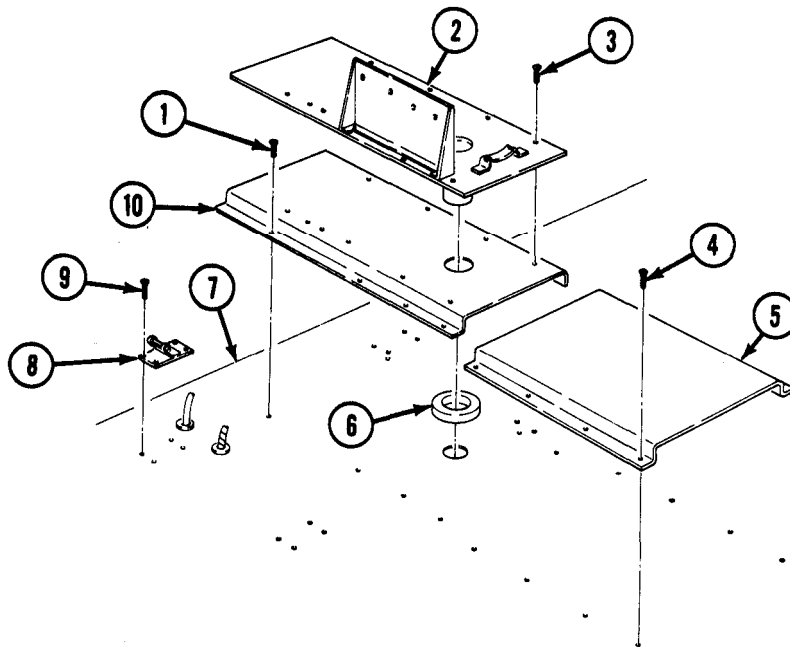

- FOLLOW-ON TASKS:**
- Install heater fuel filter (para. 14-20).
  - Install heater fuel pump (para. 14-19).
  - Install heater (para. 14-17).

## 14-19. CARGO BODY PERSONNEL HEATER FUEL PUMP REPLACEMENT

This task covers:

### a. Removal

### b. Installation

#### INITIAL SETUP:

##### APPLICABLE MODELS

M35A2, M35A2C, M36A2

##### MATERIALS/PARTS

Two lockwashers

##### REFERENCES (TM)

TM 9-2320-361-10

TM 9-2320-361-20P

##### EQUIPMENT CONDITION

- Parking brake set (TM 9-2320-361-10).
- Battery ground cable disconnected (para. 4-48).

### a. Removal

1. Close fuel shutoff valve (1).
2. Disconnect wire (14) from wire (2).
3. Disconnect fuel inlet tube (3) from elbow (8).
4. Disconnect fuel outlet tube (4) from nipple (13) and filter elbow (5).
5. Remove two screws (9), lockwashers (10), wire clamp (11), and fuel pump (7) from plate (6). Discard lockwashers (10).
6. Remove nipple (13) and elbow (12) from fuel pump (7).

### b. Installation

1. Install elbow (12) and nipple (13) on fuel pump (7).
2. Position fuel pump (7) on plate (6) and install wire clamp (11), two new lockwashers (10), and screws (9).
3. Connect fuel outlet tube (4) on nipple (13) and filter elbow (5).
4. Connect fuel inlet tube (3) on elbow (8).
5. Connect wire (14) to wire (2).
6. Open fuel shutoff valve (1).

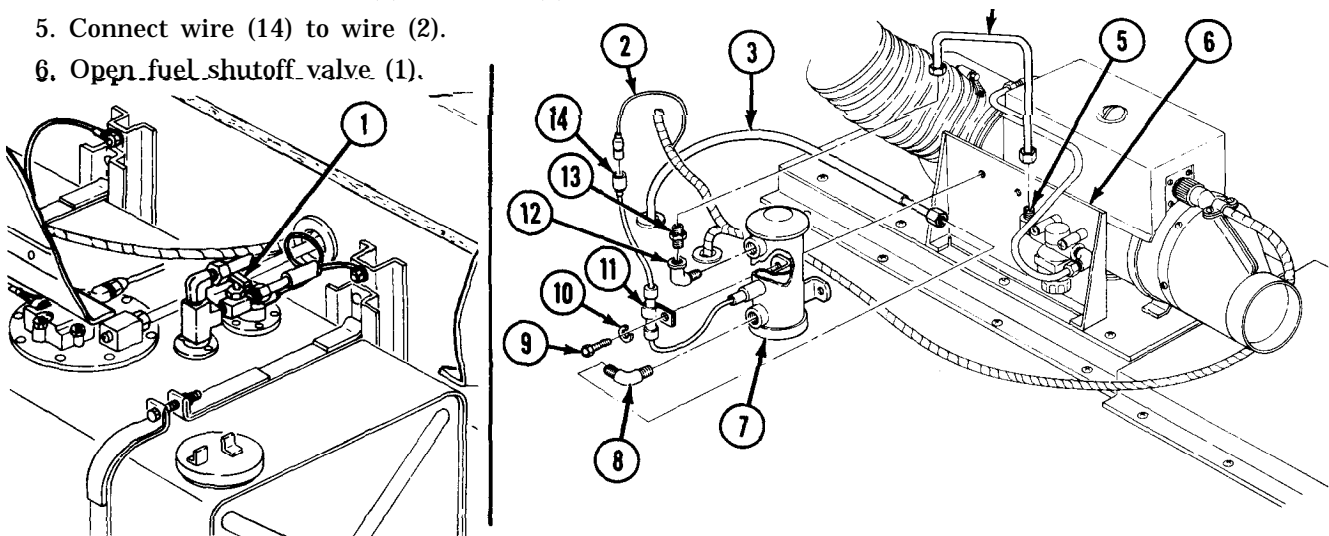

- FOLLOW-ON TASKS:
- Connect battery ground cable (para. 4-48).
  - Start heater and check operation (TM 9-2320-361-10).

**14-20. CARGO BODY PERSONNEL HEATER FUEL FILTER REPLACEMENT**

This task covers:

**a. Removal**

**b. Installation**

**INITIAL SETUP:**

APPLICABLE MODELS

M35A2, M35A2C, M36A2

REFERENCES (TM)

TM 9-2320-361-10

TM 9-2320-361-20P

MATERIALS/PARTS

Two lockwashers

EQUIPMENT CONDITION

Parking brake set (TM 9-2320-361-10).

**a. Removal**

1. Close fuel shutoff valve (1).
2. Disconnect fuel inlet tube (2) from nipple (3) and elbow (6).
3. Disconnect fuel outlet tube (12) from elbow (9) and heater (4).
4. Remove two screws (10), lockwashers (11), fuel filter (8), and two spacers (7) from mounting plate (5). Discard lockwashers (11).
5. Remove elbows (6) and (9) from fuel filter (8).

**b. Installation**

1. Install elbows (6) and (9) on fuel filter (8).
2. Install two spacers (7) and fuel filter (8) on mounting plate (5) with two new lockwashers (11) and screws (10).
3. Connect fuel outlet tube (12) to elbow (9) and heater (4).
4. Connect fuel inlet tube (2) to nipple (3) and elbow (6).
5. Open fuel shutoff valve (1).

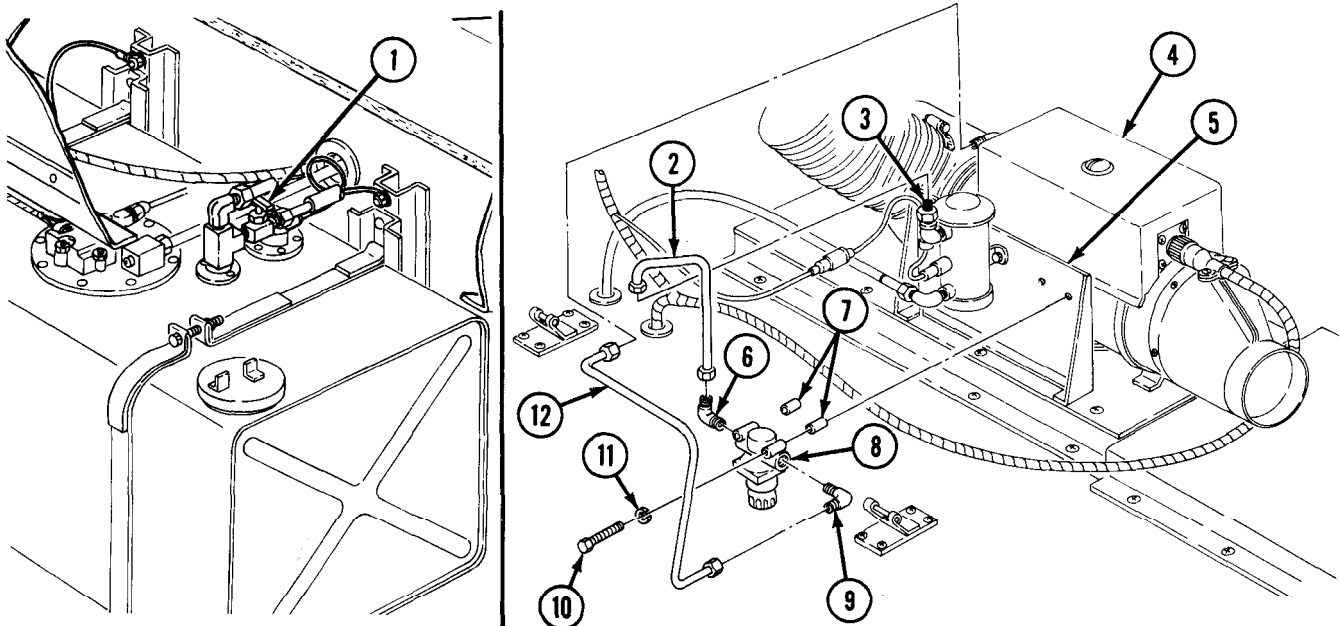

## 14-21. CARGO BODY PERSONNEL HEATER CONTROL BOX REPLACEMENT

This task covers:

### a. Removal

### b. Installation

#### INITIAL SETUP:

##### APPLICABLE MODELS

M35A2, M35A2C, M36A2

##### MATERIALS/PARTS

Two lockwashers

##### REFERENCES (TM)

TM 9-2320-361-10

TM 9-2320-361-20P

##### EQUIPMENT CONDITION

- Parking brake set (TM 9-2320-361-10).
- Battery ground cable disconnected (para. 4-48).

### a. Removal

1. Disconnect harness (6) from control box (7).
2. Disconnect wire (4) from wire (5).
3. Remove two nuts (1), lockwashers (2), ground wires (8), and control box (7) from bracket (10). Discard lockwashers (2).
4. Remove four screws (9) and bracket (10) from front cargo rack (3).

### b. Installation

1. Install bracket (10) on front cargo rack (3) with four screws (9).
2. Install control box (7) and two ground wires (8) on bracket (10) with two new lockwashers (2) and nuts (1).
3. Connect wire (5) to wire (4).
4. Connect harness (6) to control box (7).

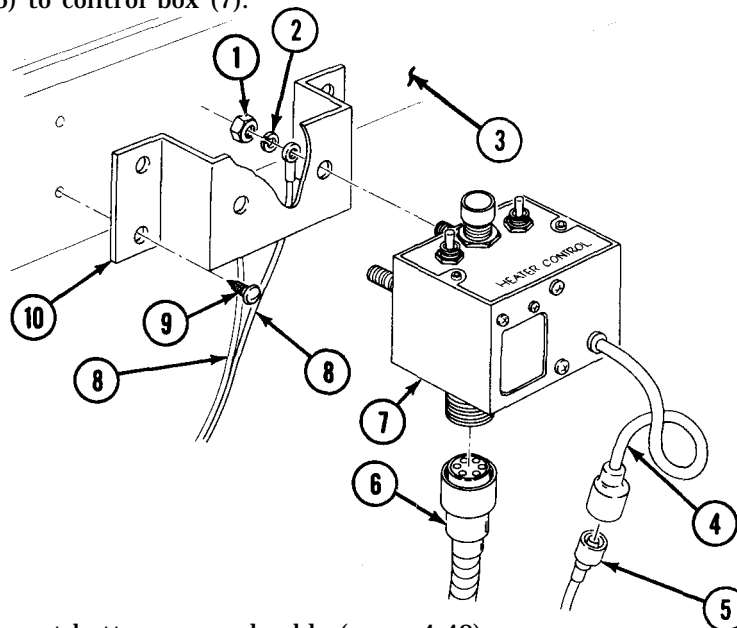

FOLLOW-ON TASK: Connect battery ground cable (para. 4-48).

<b>14-22. CARGO BODY PERSONNEL HEATER FUEL LINE REPLACEMENT</b>
---

This task covers:

**a. Removal****b. Installation****INITIAL SETUP:**APPLICABLE MODELS

All

MATERIALS/PARTS

Lockwasher

REFERENCES (TM)

TM 9-2320-361-10

TM 9-2320-361-20P

EQUIPMENT CONDITION

Parking brake set (TM 9-2320-361-10).

<b>a. Removal</b>
-------------------

1. Close fuel shutoff valve (10).
2. Disconnect fuel line (13) and elbow (12) from tee (11).
3. Disconnect fuel line (2) from shutoff valve (10).
4. Remove shutoff valve (10) and tee (11) from fuel tank (9).
5. Remove nut (4), lockwasher (5), screw (15), two clamps (6), wiring harness (7), and fuel line (2) from front cargo body panel (8). Discard lockwasher (5).
6. Remove sleeve (16) from fuel line (2) and hole (3) in cargo body floor (14).
7. Disconnect fuel line (2) from heater fuel pump (1).
8. Straighten fuel line (2) and pull from cargo body floor (14).

<b>b. Installation</b>
------------------------

1. Install fuel line (2) through hole (3) in cargo body floor (14).
2. Bend fuel line (2) and connect to heater fuel pump (1).
3. Place sleeve (16) on fuel line (2) and install in hole (3).
4. Install tee (11) and shutoff valve (10) on fuel tank (9).
5. Connect fuel line (2) to shutoff valve (10).
6. Connect elbow (12) and fuel line (13) to tee (11).
7. Install fuel line (2) and wiring harness (7) on front cargo body panel (8) with two clamps (6), screw (15), new lockwasher (5), and nut (4).
8. Open fuel shutoff valve (10).

14-22. CARGO BODY PERSONNEL HEATER FUEL LINE REPLACEMENT (Contd)

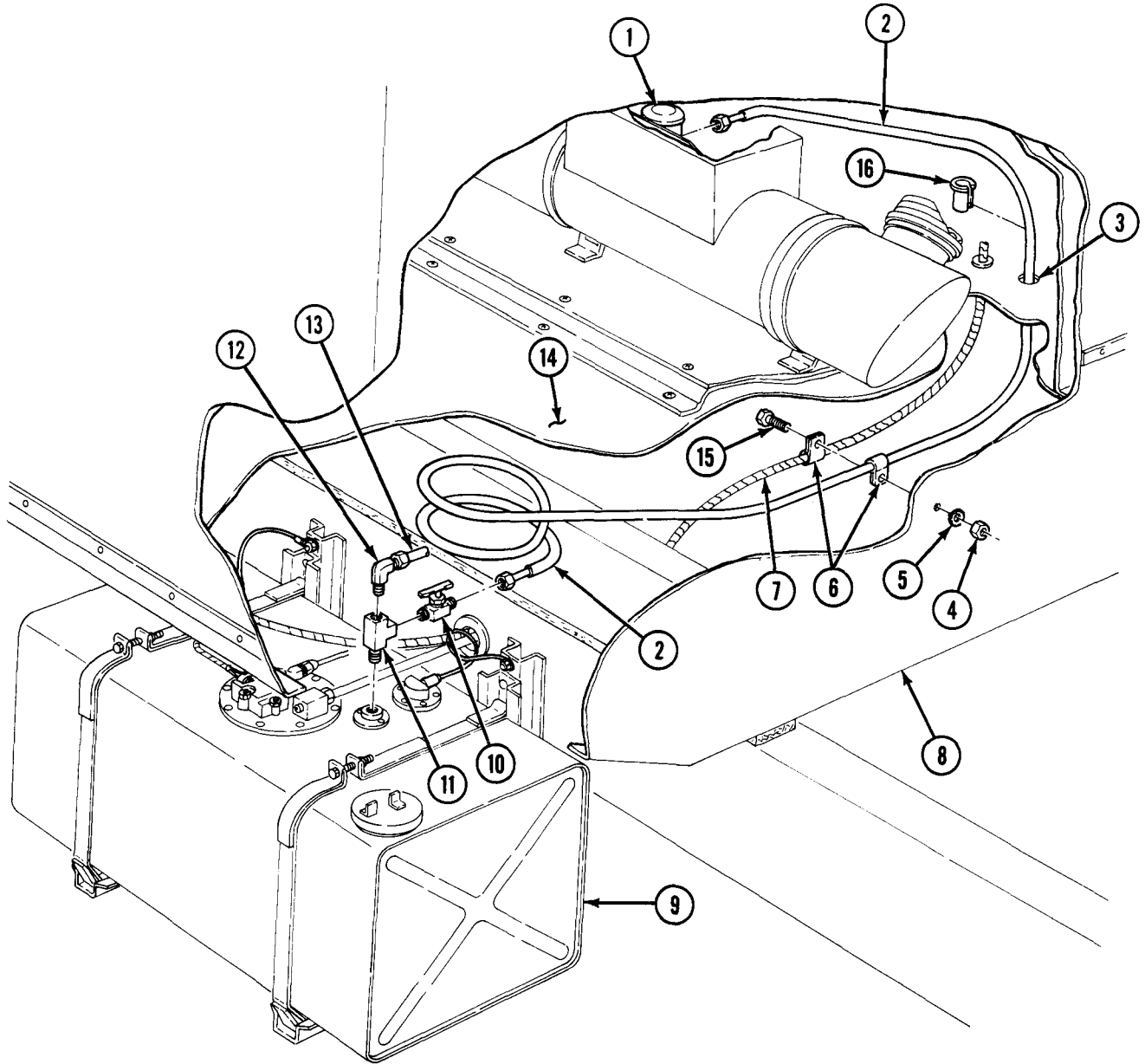

FOLLOW-ON TASK: Start heater and check operation (TM 9-2320-361-10).

**14-23. CARGO BODY PERSONNEL HEATER DIVERTER AND DUCT REPLACEMENT**

This task covers:

**a. Removal**

**b. Installation**

INITIAL SETUP:

APPLICABLE MODELS

M35A2, M35A2C, M36A2

EQUIPMENT CONDITION

Parking brake set (TM 9-2320-361-10).

REFERENCES (TM)

TM 9-2320-361-10

TM 9-2320-361-20P

**a. Removal**

1. Remove two clamps (12) and duct (13) from outlet adapter (16) and diverter (10).
2. Remove screw (14), clamp (15), and duct (13) from front cargo rack (1).
3. Remove two clamps (3) and duct (6) from diverter (10) and heater (2).
4. Remove screw (4), clamp (5), and duct (6) from front cargo rack (1).
5. Remove plug (7) and screw (8) from diverter (10).
6. Rotate handle (11) counterclockwise to close damper (9) and expose second screw (8).
7. Remove screw (8) and diverter (10) from front cargo rack (1).

**b. Installation**

1. Position diverter (10) on front cargo rack (1) and install screw (8) and plug (7).
2. Rotate handle (11) clockwise to open damper (9) and install second screw (8).
3. Install duct (6) on heater (2) and diverter (10) with two clamps (3).
4. Install duct (6) on front cargo rack (1) with clamp (5) and screw (4).
5. Install duct (13) on diverter (10) and outlet adapter (16) with two clamps (12).
6. Install duct (13) on front cargo rack (1) with clamp (15) and screw (14).

14-23. CARGO BODY PERSONNEL HEATER DIVERTER AND DUCT REPLACEMENT (Contd)

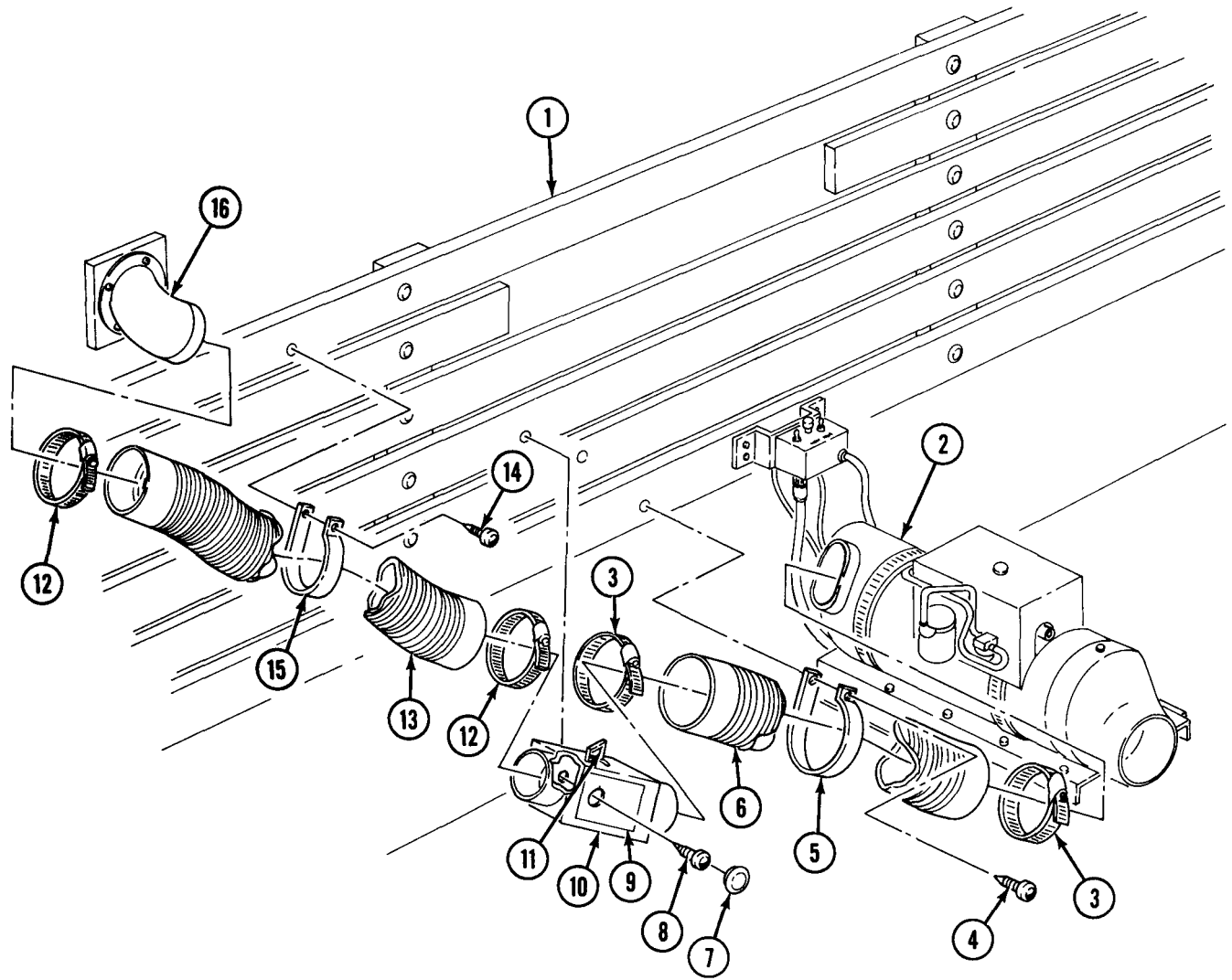



Section II. VAN BODY PRIMARY AND SECONDARY HEATER KIT MAINTENANCE

**14-24. VAN BODY PRIMARY AND SECONDARY HEATER KIT MAINTENANCE INDEX**

PARA. NO.	TITLE	PAGE NO.
14-25.	Primary Heater Fuel Pump Replacement	14-36
14-26.	Primary Heater Fuel Pump Cover Replacement	14-38
14-27.	Primary Heater Fuel Filter Replacement	14-39
14-28.	Primary Heater Fuel Lines Replacement	14-40
14-29.	Primary Heater Fuel Shutoff and Coupling Replacement	14-44
14-30.	Primary and Secondary Heater Exhaust Tube Replacement	14-46
14-31.	Primary Heater Air Inlet Duct Replacement	14-47
14-32.	Primary Heater and Duct Replacement	14-48
14-33.	Primary and Secondary Heater Switches Replacement	14-52
14-34.	Primary Heater Auxiliary Duct Replacement	14-54
14-35.	Secondary Heater Fuel Lines Replacement	14-55
14-36.	Secondary Heater and Duct Replacement	14-56

**14-25. PRIMARY HEATER FUEL PUMP REPLACEMENT**

This task covers:

**a. Removal**

**b. Installation**

**INITIAL SETUP:**

APPLICABLE MODELS

M109A3 and M185A3

MATERIALS/PARTS

Antiseize tape (Appendix C, Item 27)

REFERENCES (TM)

TM 9-2320-361-10  
 TM 9-2320-361-20P

EQUIPMENT CONDITION

- Parking brake set (TM 9-2320-361-10).
- Pump cover removed (para. 14-26).
- Battery ground cable disconnected (para. 4-48).

GENERAL SAFETY INSTRUCTIONS

Keep fire extinguisher nearby when working with open fuel lines.

## 14-25. PRIMARY HEATER FUEL PUMP REPLACEMENT (Contd)

### WARNING

Do not perform this procedure while smoking or within 50 feet of sparks or open flame. Fuel is flammable and can explode easily, causing injury or death to personnel and damage to equipment.

#### a. Removal

1. Disconnect wire connector (7) from connector (8).
2. Remove fuel lines (9) from elbows (6).
3. Remove two elbows (6) from heater fuel pump (1).
4. Remove two screws (5), washers (4), clamp (2), wire (3), and heater fuel pump (1) from van body (10).

#### b. Installation

### NOTE

Wrap male pipe threads with antiseize tape prior to installation.

1. Install heater fuel pump (1), clamp (2), and wire (3) on van body (10) with two washers (4) and screws (5).
2. Install two elbows (6) on heater fuel pump (1).
3. Install two fuel lines (9) on elbows (6).
4. Connect wire connector (7) to connector (8).

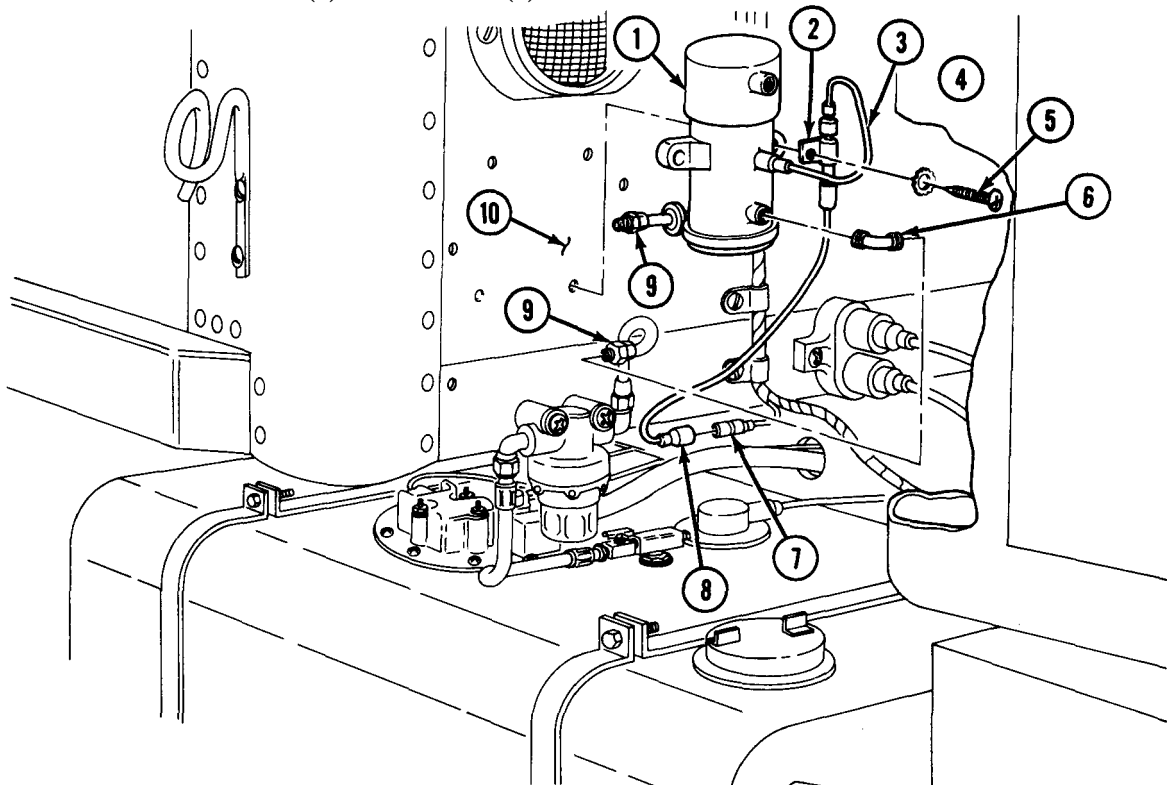

FOLLOW-ON TASKS: •Install pump cover (para. 14-26).  
•Connect battery ground cable (para. 4-48).

## 14-26. PRIMARY HEATER FUEL PUMP COVER REPLACEMENT

This task covers:

### a. Removal

### b. Installation

INITIAL SETUP:

APPLICABLE MODELS  
M109A3 and M185A3

EQUIPMENT CONDITION  
Parking brake set (TM 9-2320-361-10).

REFERENCES (TM)  
TM 9-2320-361-10  
TM 9-2320-361-20P

### a. Removal

Remove seven screws (2) and fuel pump cover (3) from van body (1).

### b. Installation

Install fuel pump cover (3) on van body (1) with seven screws (2).

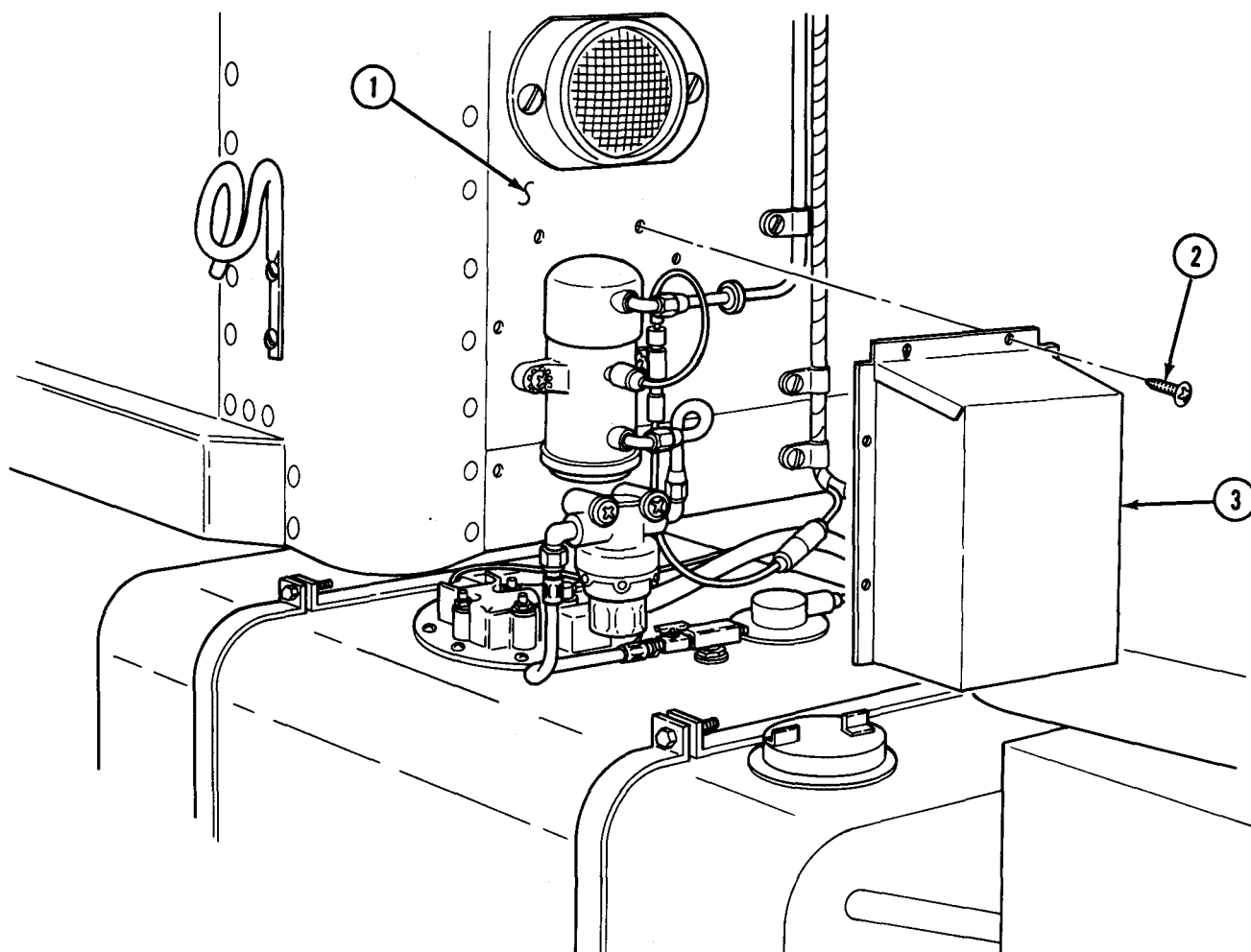

## 14-27. PRIMARY HEATER FUEL FILTER REPLACEMENT

This task covers:

### a. Removal

### b. Installation

#### INITIAL SETUP:

##### APPLICABLE MODELS

M109A3 and M185A3

##### MATERIALS/PARTS

Antiseize tape (Appendix C, Item 27)

##### REFERENCES (TM)

TM 9-2320-361-10

TM 9-2320-361-20P

##### EQUIPMENT CONDITION

Parking brake set (TM 9-2320-361-10).

##### GENERAL SAFETY INSTRUCTIONS

Keep fire extinguisher nearby when working with open fuel lines.

### a. Removal

#### **WARNING**

Do not perform this procedure while smoking or within 50 feet of sparks or open flame. Fuel is flammable and can explode easily causing injury or death to personnel and damage to equipment.

1. Remove fuel line (8) from elbow (7) and fuel tube (2) from elbow (3).
2. Remove elbows (3) and (7) from filter (6).
3. Remove two screws (5), washers (4), and filter (6) from van body (1).

### b. Installation

#### **NOTE**

Wrap male pipe threads with antiseize tape prior to installation.

1. Install filter (6) on van body (1) with two washers (4) and screws (5).
2. Install elbows (3) and (7) on filter (6).
3. Install fuel tube (2) on elbow (3) and fuel line (8) on elbow (7).

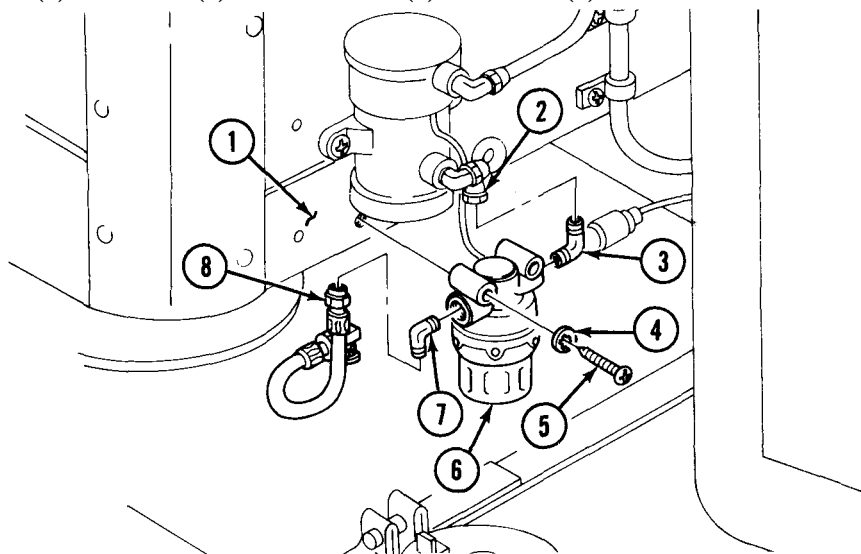

## 14-28. PRIMARY HEATER FUEL LINES REPLACEMENT

**This task covers:**

- |  |   |
|--|---|
| a. Fuel Tank Shutoff-To-Fiter Hose Removal       | d. Filter-To-Pump Inlet Tube Installation   |
| b. Fuel Tank Shutoff-To-Filter Hose Installation | e. Pump Outlet-To-Adapter Tube Removal      |
| c. Filter-To-Pump Inlet Tube Removal             | f. Pump Outlet-To-Adapter Tube Installation |
|  | g. Fuel Heater-To-Adapter Tube Removal      |
|  | h. Fuel Heater-To-Adapter Tube Installation |

**INITIAL SETUP:**

**APPLICABLE MODELS**

M109A3 and M185A3

**MATERIALS/PARTS**

Antiseize tape (Appendix C, Item 27)

**REFERENCES (TM)**

TM 9-2320-361-10

**EQUIPMENT CONDITION**

- Parking brake set (TM 9-2320-361-10).
- Pump cover removed (para. 14-26).

**GENERAL SAFETY INSTRUCTIONS**

Keep fire extinguisher nearby when working with open fuel lines.

**WARNING**

Do not perform this procedure while smoking or within 50 feet of sparks or open flame. Fuel is flammable and can explode easily, causing injury or death to personnel and damage to equipment.

**a. Fuel Tank Shutof-To-Filter Hose Removal**

**NOTE**

Have drainage container ready to catch fuel.

1. Remove hose (5) from shutoff (4) and allow fuel to drain.
2. Remove hose (5) from elbow (6).

**b. Fuel Tank Shutoff-To-Filter Hose Installation**

**NOTE**

Wrap male pipe threads with antiseize tape prior to installation.

1. Install hose (5) on elbow (6).
2. Install hose (5) on fuel shutoff (4).

**c. Filter-To-Pump Inlet Tube Removal**

Remove tube (2) from elbow (1) and elbow (3).

**d. Filter-To-Pump Inlet Tube Installation**

Install tube (2) on elbow (1) and elbow (3).

14-28. PRIMARY HEATER FUEL LINES REPLACEMENT (Contd)

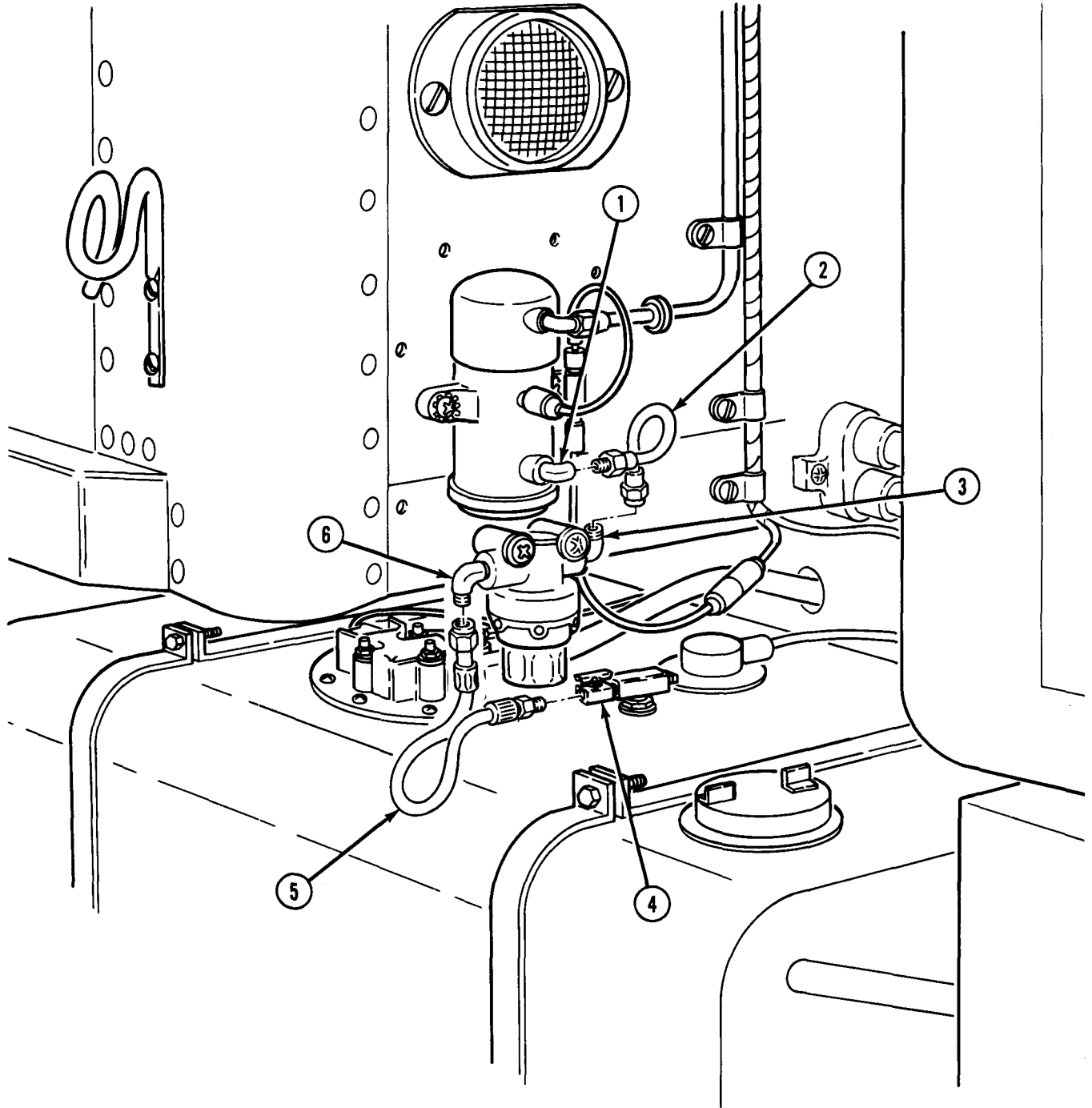

**14-28. PRIMARY HEATER FUEL LINES REPLACEMENT (Contd)**

**e. Pump Outlet-To-Adapter Tube Removal**

1. Remove screw (4) and clamp (5) from fuel line (6) and van body (1).
2. Remove fuel line (6) from elbows (3) and (7).
3. Remove elbow (3) from adapter (2) and elbow (7) from pump outlet (8).

**f. Pump Outlet-To-Adapter Tube Installation**

1. Install elbow (3) on adapter (2) and elbow (7) on pump outlet (8).
2. Install fuel line (6) on elbows (3) and (7).
3. Install clamp (5) and fuel line (6) on van body (1) with screw (4).

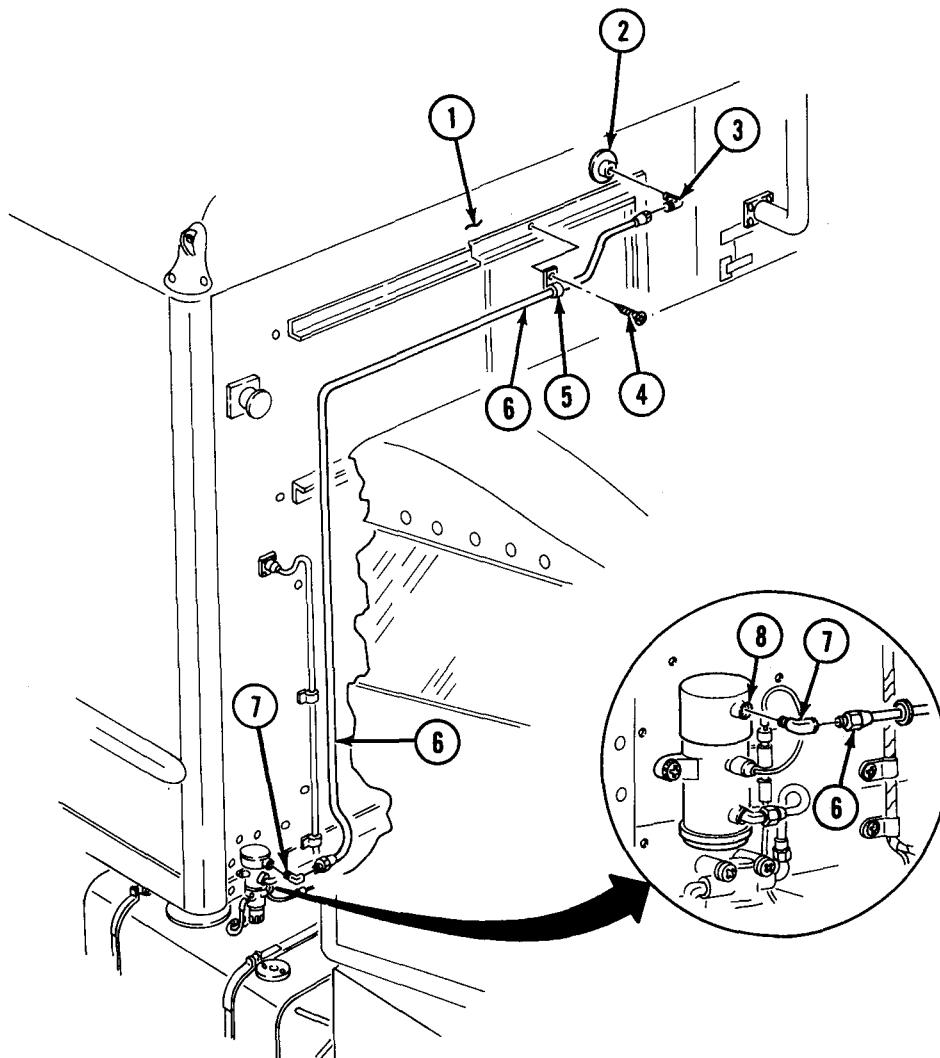

**14-28. PRIMARY HEATER FUEL LINES REPLACEMENT (Contd)****g. Fuel Heater-To-Adapter Tube Removal**

1. Remove tube (9) from elbows (11) and (13).
2. Remove elbow (11) from adapter (10) and elbow (13) from nipple (12).

**h. Fuel Heater-To-Adapter Tube Installation**

1. Install elbow (11) on adapter (10) and elbow (13) on nipple (12).
2. Install tube (9) on elbows (11) and (13).

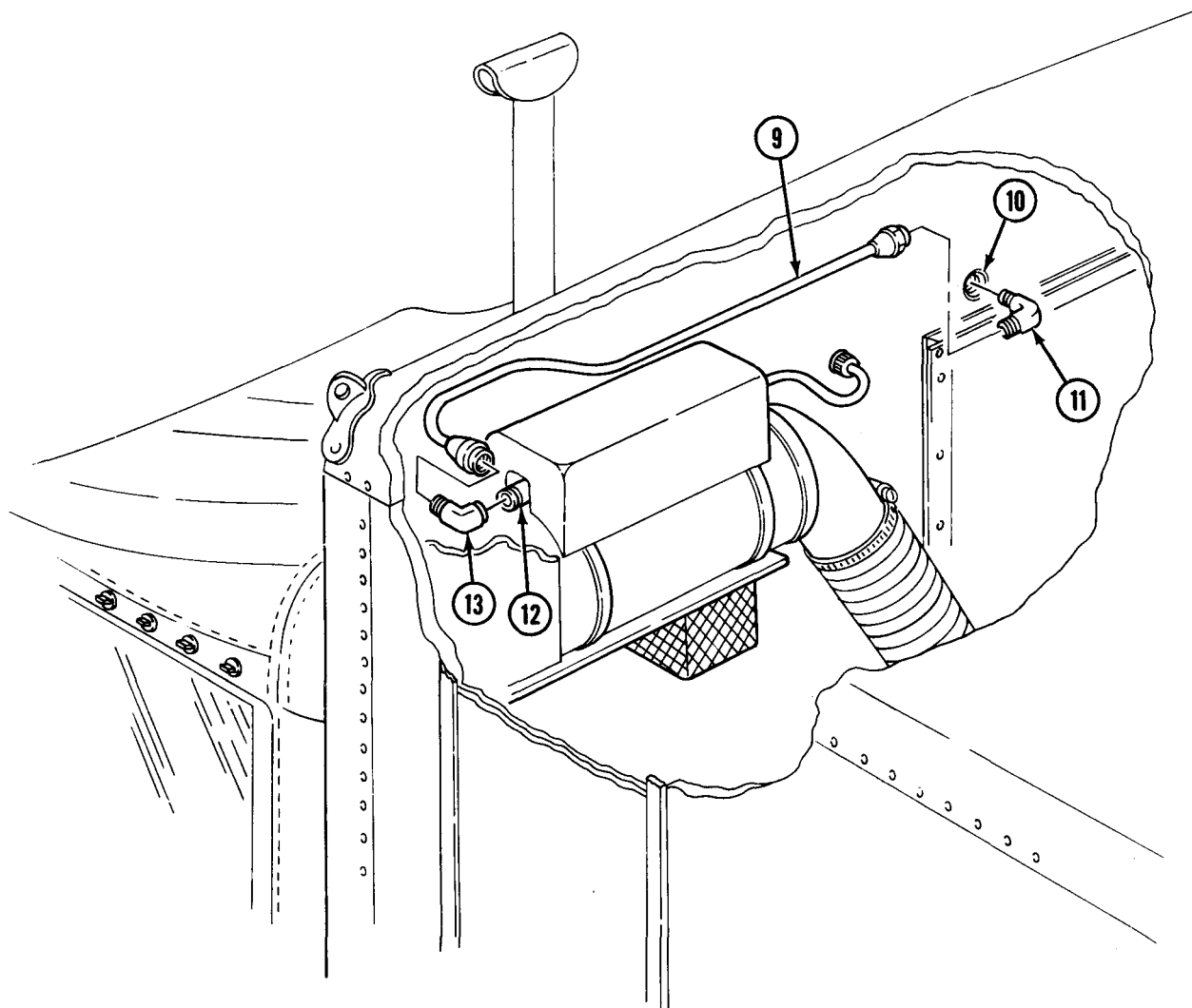

FOLLOW-ON TASK: Install pump cover (para. 14-26).



**14-29. PRIMARY HEATER FUEL SHUTOFF AND COUPLING REPLACEMENT**

This task covers:

**a. Removal**

**b. Installation**

**INITIAL SETUP:**

APPLICABLE MODELS

M019A3 and M185A3

MATERIALS/PARTS

Three gaskets  
Antiseize tape (Appendix C, Item 27)

REFERENCES (TM)

TM 9-2320-361-10  
TM 9-2320-361-20P

EQUIPMENT CONDITION

- Parking brake set (TM 9-2320-361-10).
- Fuel tank drained (para. 3-24).
- Fuel tank filler cap and sleeve removed (para. 3-22).

GENERAL SAFETY INSTRUCTIONS

Keep fire extinguisher nearby when working with open fuel lines.

**WARNING**

Do not perform this procedure while smoking or within 50 feet of sparks or open flame. Fuel is flammable and can explode easily, causing injury or death to personnel and damage to equipment.

**NOTE**

Have drainage container ready to catch fuel.

**a. Removal**

1. Remove hose (8) from shutoff (1) and allow fuel to drain from hose (8).
2. Remove shutoff (1) from nipple (2).
3. Remove nipple (2) and plug (3) from tee (4).
4. Remove tee (4) from coupling (5).
5. Reach through fuel fill port (10) and remove nut (12), sleeve (13), and tube (11) from adapter (14).
6. Remove adapter (14) from nut (15).
7. Remove nut (15), two gaskets (6), washer (7), coupling (5), gasket (6), and washer (7) from fuel tank (9). Discard gaskets (6).

**NOTE**

Wrap male pipe threads with antiseize tape prior to installation.

**b. Installation**

1. Reach through fuel tank fill port (10) and install nut (15), two new gaskets (6), washers (7), new gasket (6), and coupling (5) on fuel tank (9).
2. Install adapter (14) on nut (15).
3. Install sleeve (13), nut (12), and tube (11) on adapter (14).
4. Install tee (4) on coupling (5).
5. Install nipple (2) and plug (3) on tee (4).
6. Install shutoff (1) on nipple (2).
7. Install hose (8) on shutoff (1).

14-29. PRIMARY HEATER FUEL SHUTOFF AND COUPLING REPLACEMENT (Contd)

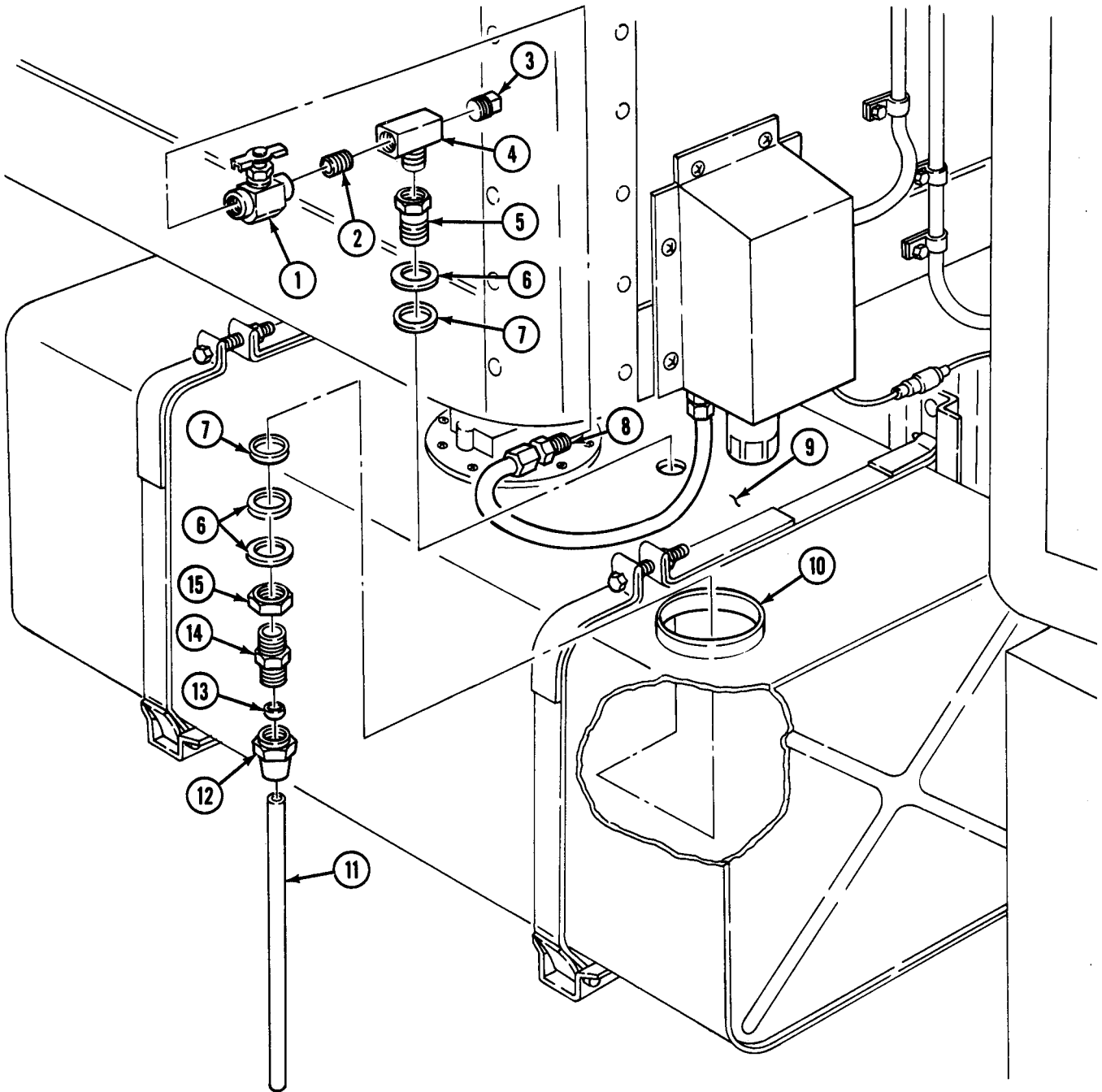

FOLLOW-ON TASKS: • Fill fuel tank (TM 9-2320-361-10).  
 • Install fuel tank filler cap and sleeve (para. 3-22).

**14-30. PRIMARY AND SECONDARY HEATER EXHAUST TUBE REPLACEMENT**

This task covers:

**a. Removal**

**b. Installation**

**INITIAL SETUP:**

APPLICABLE MODELS

M109A3 and M185A3

MATERIALS/PARTS

O-ring

REFERENCES (TM)

TM 9-2320-361-10

TM 9-2320-361-20P

EQUIPMENT CONDITION

Parking brake set (TM 9-2320-361-10).

GENERAL SAFETY INSTRUCTIONS

Do not touch hot exhaust system components with bare hands.

**a. Removal**

**WARNING**

Do not touch hot exhaust system components with bare hands; injury to personnel will result.

1. Remove two screws (4) and washers (2) from clamp (3) and van body (7).
2. Remove nut (1), washer (2), screw (9), and clamp (3) from outside exhaust tube (5).
3. Remove four screws (8), O-ring (6), and outside exhaust tube (5) from van body (7). Discard O-ring (6).

**b. Installation**

1. Install new O-ring (6) and outside exhaust tube (5) on van body (7) with four screws (8).
2. Install clamp (3) on outside exhaust tube (5) with screw (9), washer (2), and nut (1).
3. Install clamp (3) on van body (7) with two screws (4) and washers (2).

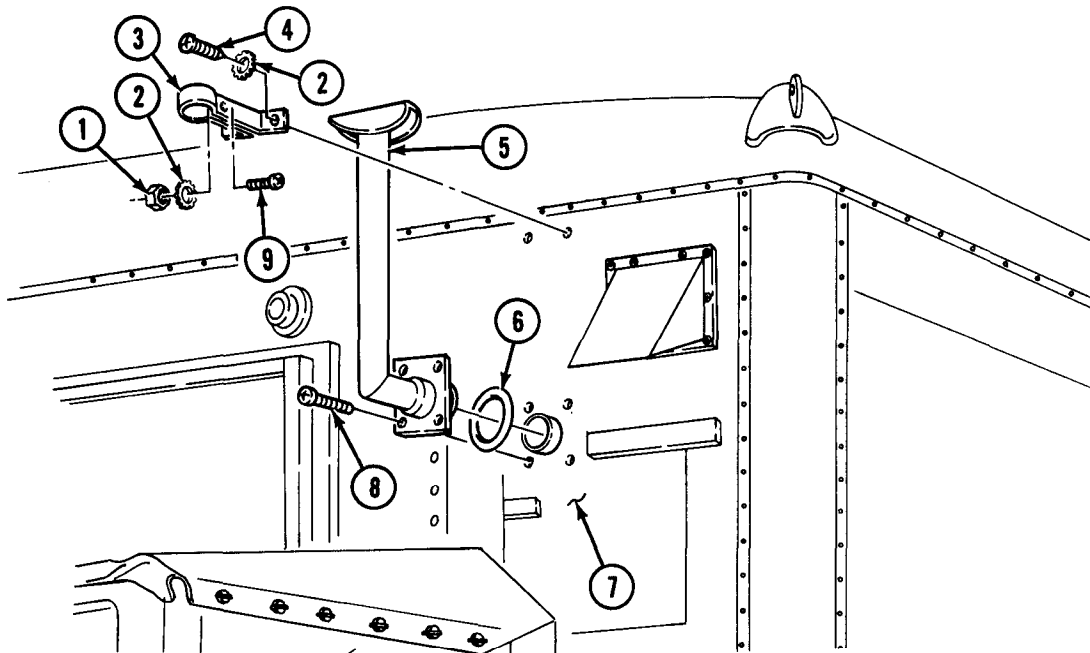

**14-31. PRIMARY HEATER AIR INLET DUCT REPLACEMENT**

This task covers:

**a. Removal**

**b. Installation**

**INITIAL SETUP:**

APPLICABLE MODELS  
M109A3 and M185A3

EQUIPMENT CONDITION  
Parking brake set (TM 9-2320-361-10).

REFERENCES (TM)  
TM 9-2320-361-10  
TM 9-2320-361-20P

**a. Removal**

Remove four screws (1) and duct (2) from van body (3).

**b. Installation**

Install duct (2) on van body (3) with four screws (1).

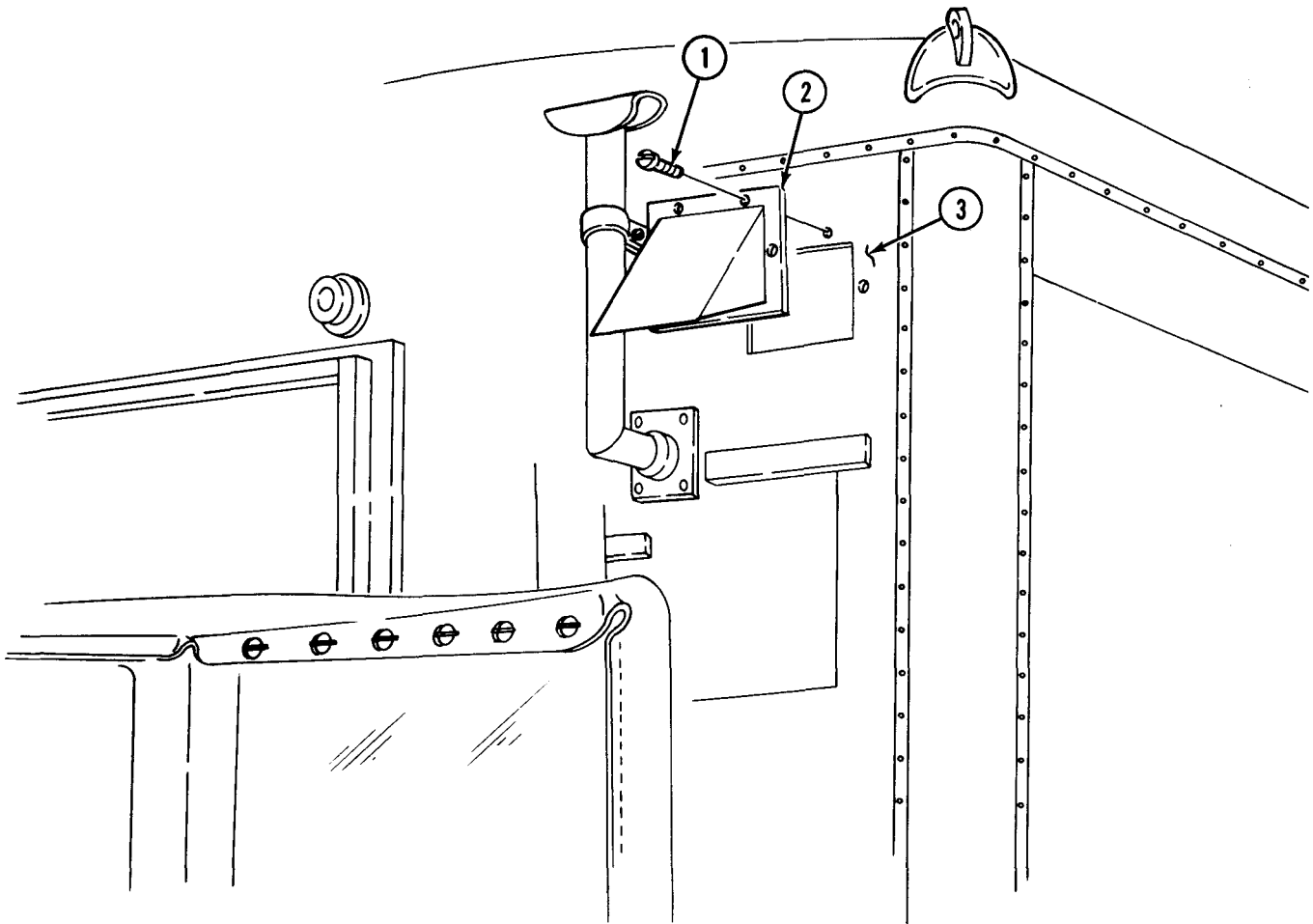

**14-32. PRIMARY HEATER AND DUCT REPLACEMENT**

This task covers:

- a. Heater Removal
- b. Duct Removal

- c. Duct Installation
- d. Heater Installation

**INITIAL SETUP:**

APPLICABLE MODELS

M109A3 and M185A3

MATERIALS/PARTS

O-ring  
Two gaskets

REFERENCES (TM)

TM 9-2320-361-10  
TM 9-2320-361-20P

EQUIPMENT CONDITION

Parking brake set (TM 9-2320-361-10).

**a. Heater Removal**

1. Remove heater harness (7) from heater (3).
2. Remove clamp (5) and duct (6) from adapter (4).
3. Remove four screws (10) and adapter (4) from heater (3).
4. Remove three screws (2) and cover (1) from heater box (23).
5. Remove two clamps (9), heater (3), washer (11), and O-ring (12) from support (14). Discard O-ring (12).
6. Remove screw (21) and two screws (22) from guard (20).
7. Remove guard (20) from support (14) and van wall (8).
8. Remove four screws (18) from exhaust tube (17) and support (14). Remove four screws (16) from exhaust tube (17) and van wall (8).
9. Remove exhaust tube (17) and gaskets (19) and (15) from support (14) and van wall (8). Discard gaskets (15) and (19).
10. Remove four screws (13) and support (14) from van wall (8).

14-32. PRIMARY HEATER AND DUCT REPLACEMENT (Contd)

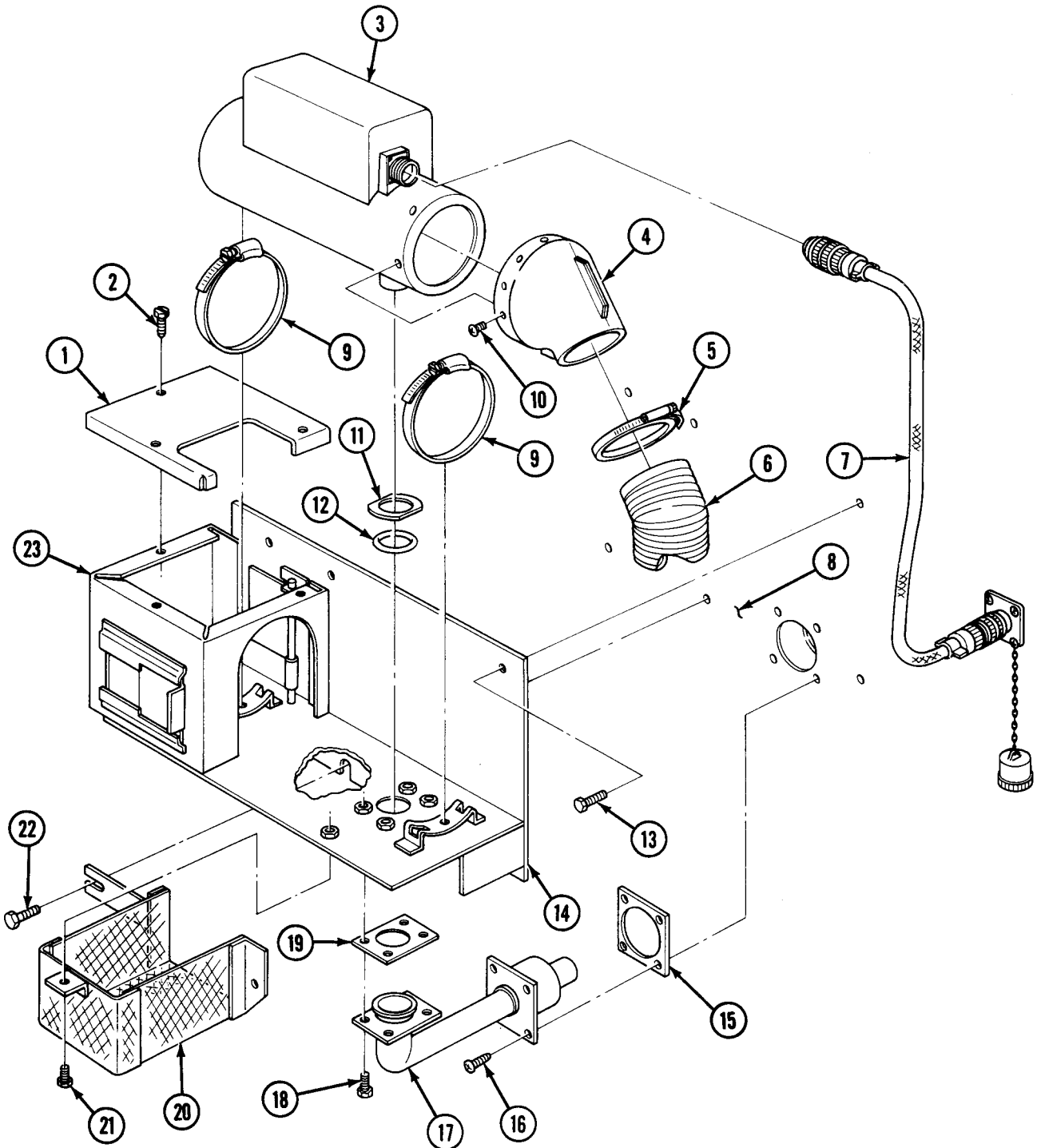

**14-32. PRIMARY HEATER AND DUCT REPLACEMENT (Contd)**

**b. Duct Removal**

1. Remove screw (3) and strap (2) from frame (1).
2. Remove two screws (8), screw (9), and strap (7) from deflector (11) and van wall (13).
3. Remove three screws (10) and deflector (11) from floor (12).
4. Remove clamp (5) and adapter (6) from duct (4).

**c. Duct Installation**

1. Install adapter (6) and clamp (5) on duct (4).
2. Install deflector (11) on floor (12) with three screws (10).
3. Install strap (7) and deflector (11) on van wall (13) with two screws (8) and screw (9). Buckle strap (7) on adapter (6).
4. Install strap (2) on frame (1) with screw (3). Buckle strap (2) on duct (4).

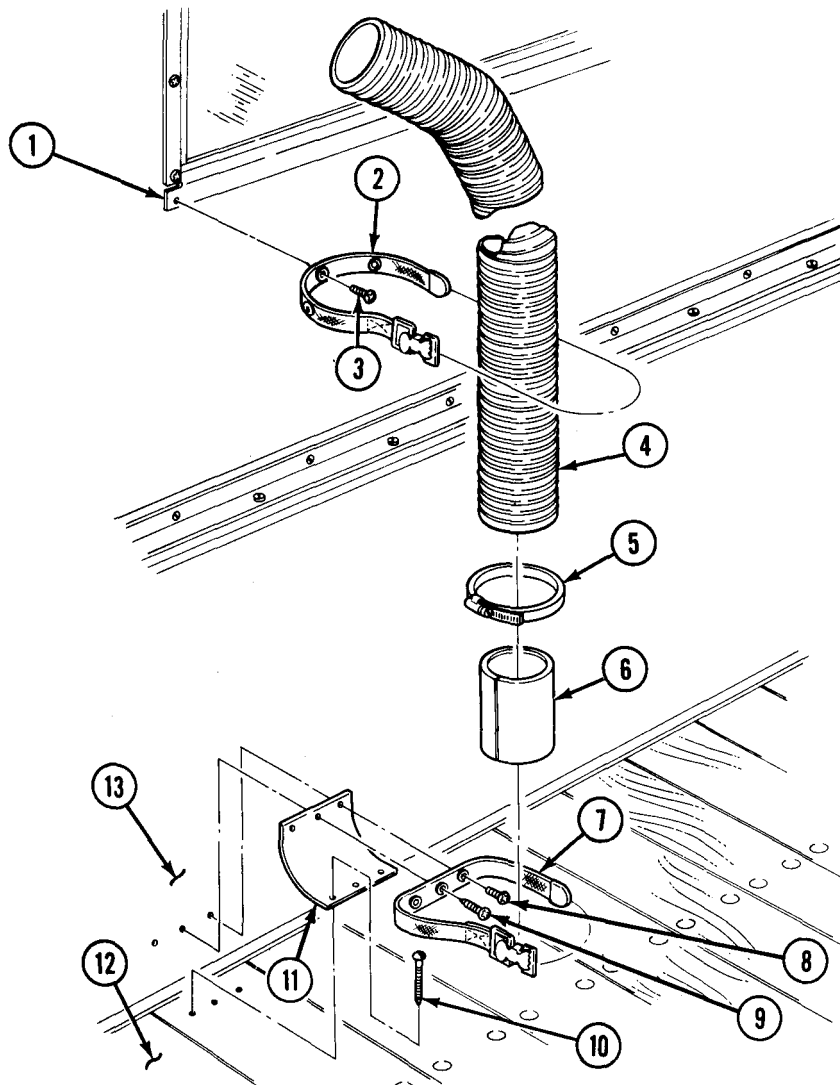

## 14-32. PRIMARY HEATER AND DUCT REPLACEMENT (Contd)

### d. Heater Installation

1. Install support (22) on van wall (13) with four screws (21).
2. Install exhaust tube (25) and new gasket (23) on van wall (13) with four screws (24). Install exhaust tube (25) and new gasket (27) on support (22) with four screws (26).
3. Install guard (28) on van wall (13) with two screws (30). Install guard (28) on support (22) with screw (29).
4. Install new O-ring (34), washer (35), and heater (16) on support (22) with two clamps (32).
5. Install cover (14) on heater box (31) with three screws (15).
6. Install adapter (17) on heater (16) with four screws (33).
7. Install duct (19) on adapter (17) with clamp (18).
8. Install heater harness (20) on heater (16).

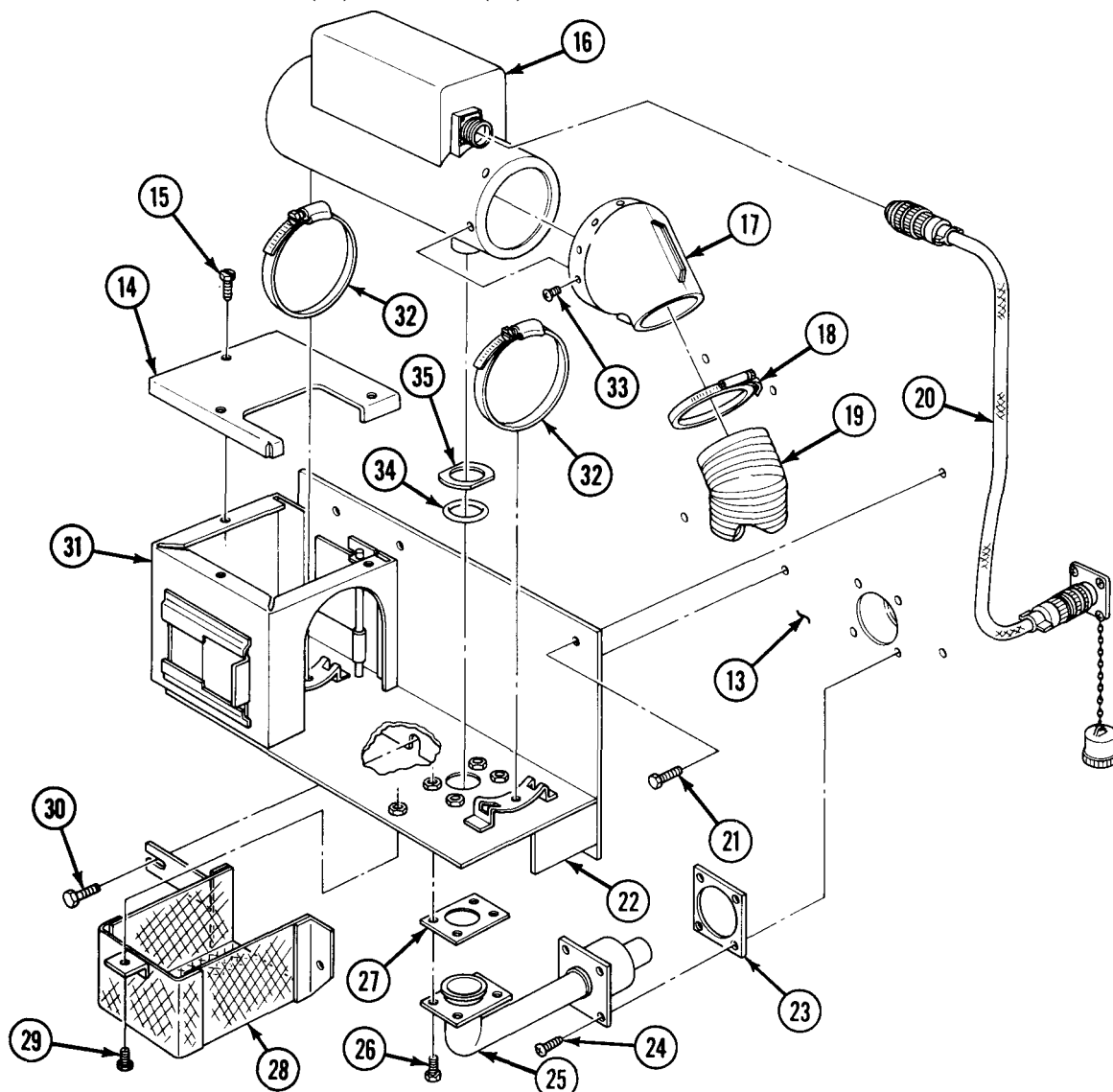

FOLLOW-ON TASK: Check heater for proper operation (TM 9-2320-361-10).



**14-33. PRIMARY AND SECONDARY HEATER SWITCHES REPLACEMENT**

This task covers:

**a. Removal**

**b. Installation**

**INITIAL SETUP:**

APPLICABLE MODELS

All

REFERENCES (TM)

TM 9-2320-361-10

TM 9-2320-361-20P

EQUIPMENT CONDITION

- Parking brake set (TM 9-2320-361-10).
- Battery ground cable disconnected (para. 4-48).

**NOTE**

Primary and secondary heater switches replacement procedures are the same.

**a. Removal**

**NOTE**

Tag all wires for installation.

1. Loosen six screws (6) and remove converter (5) from screws (6) and van wall (7).
2. Remove fourteen screws (14) and cover (15) from converter (5).
3. Remove two screws (18), washers (17), and wires (3) and (19) from HIGH-LOW switch (16).
4. Remove four screws (10), washers (9), and wires (4), (11), (3), and (12) from RUN-OFF-START switch (13).
5. Remove jumper (8) from RUN-OFF-START switch (13).
6. Remove two screws (1), mounting plate (2), and RUN-OFF-START switch (13) from cover (15).
7. Remove two screws (1), mounting plate (2), and HIGH-LOW switch (16) from cover (15).

**b. Installation**

1. Install HIGH-LOW switch (16) and mounting plate (2) on cover (15) with two screws (1).
2. Install RUN-OFF-START switch (13) and mounting plate (2) on cover (15) with two screws (1).
3. Install jumper (8) on RUN-OFF-START switch (13).
4. Install wires (4), (11), (3), and (12) on RUN-OFF-START switch (13) with four washers (9) and screws (10).
5. Install wires (3) and (19) on HIGH-LOW switch (16) with two washers (17) and screws (18).
6. Install cover (15) on converter (5) with fourteen screws (14).
7. Install converter (5) on van wall (7) with six screws (6). Tighten screws (6).

**14-33. PRIMARY AND SECONDARY HEATER SWITCHES REPLACEMENT (Contd)**

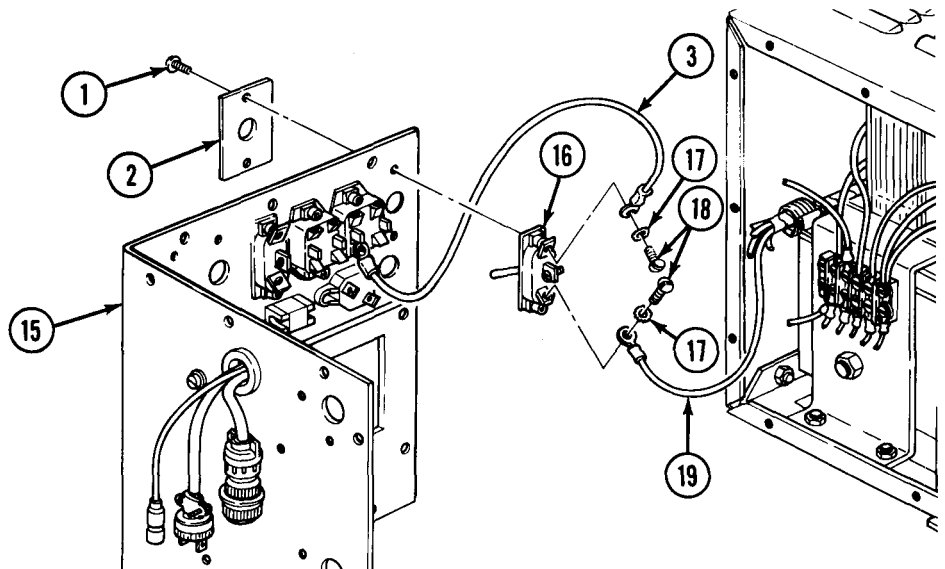
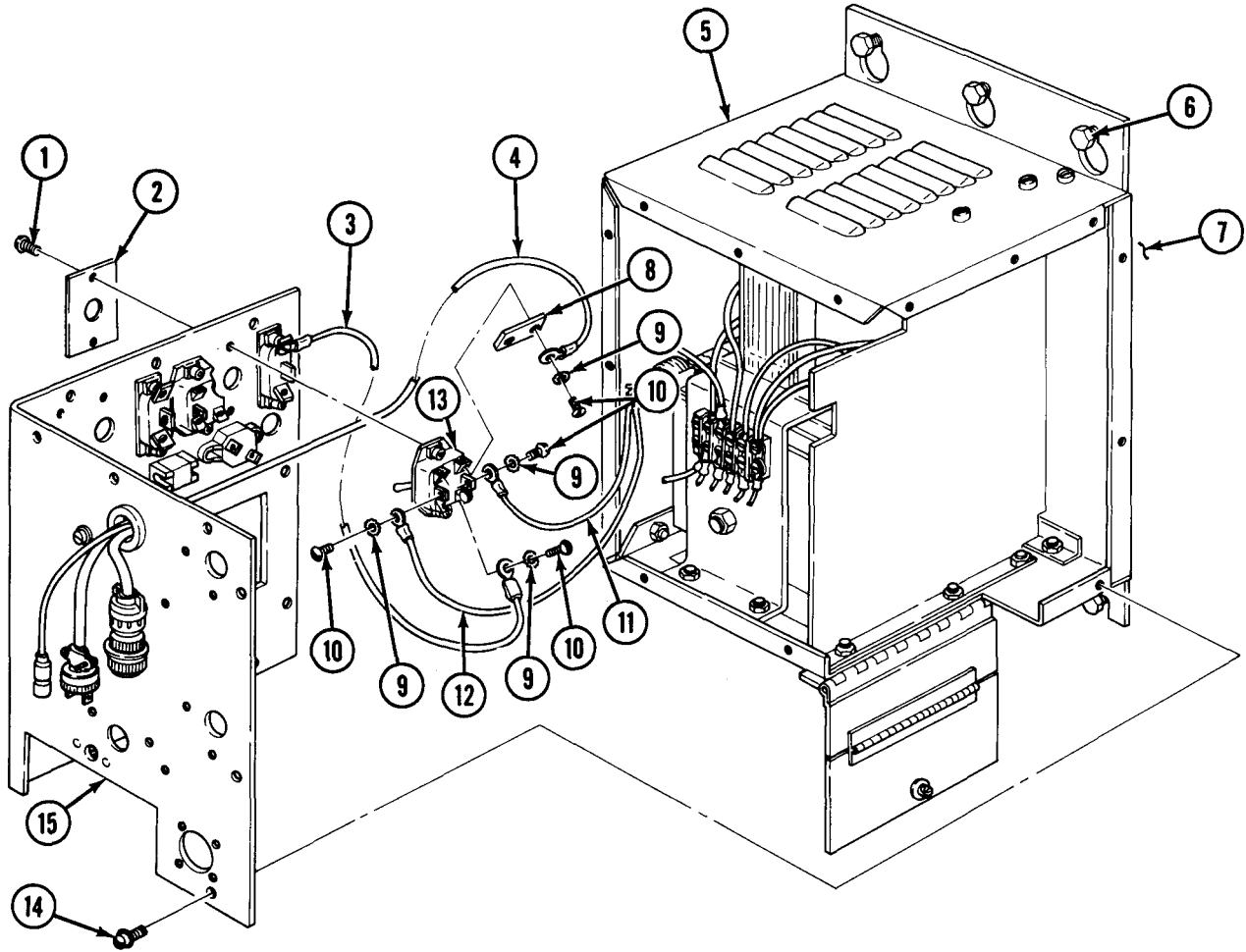

FOLLOW-ON TASK: Connect battery ground cable (para. 4-48).

**14-34. PRIMARY HEATER AUXILIARY DUCT REPLACEMENT**

This task covers:

**a. Removal**

**b. Installation**

INITIAL SETUP:

APPLICABLE MODELS  
M109A3 and M185A3

EQUIPMENT CONDITION  
Parking brake set (TM 9-2320-361-10).

REFERENCES (TM)  
TM 9-2320-361-10  
TM 9-2320-361-20P

**NOTE**

Auxiliary duct is normally located on van front wall prior to secondary heater installation.

**a. Removal**

1. Unbuckle three straps (2) and remove auxiliary duct (1) from van ceiling (4).
2. Remove three screws (3) and straps (2) from van ceiling (4).

**b. Installation**

1. Install three straps (2) on van ceiling (4) with three screws (3).
2. Install auxiliary duct (1) on van ceiling (4) with three straps (2).

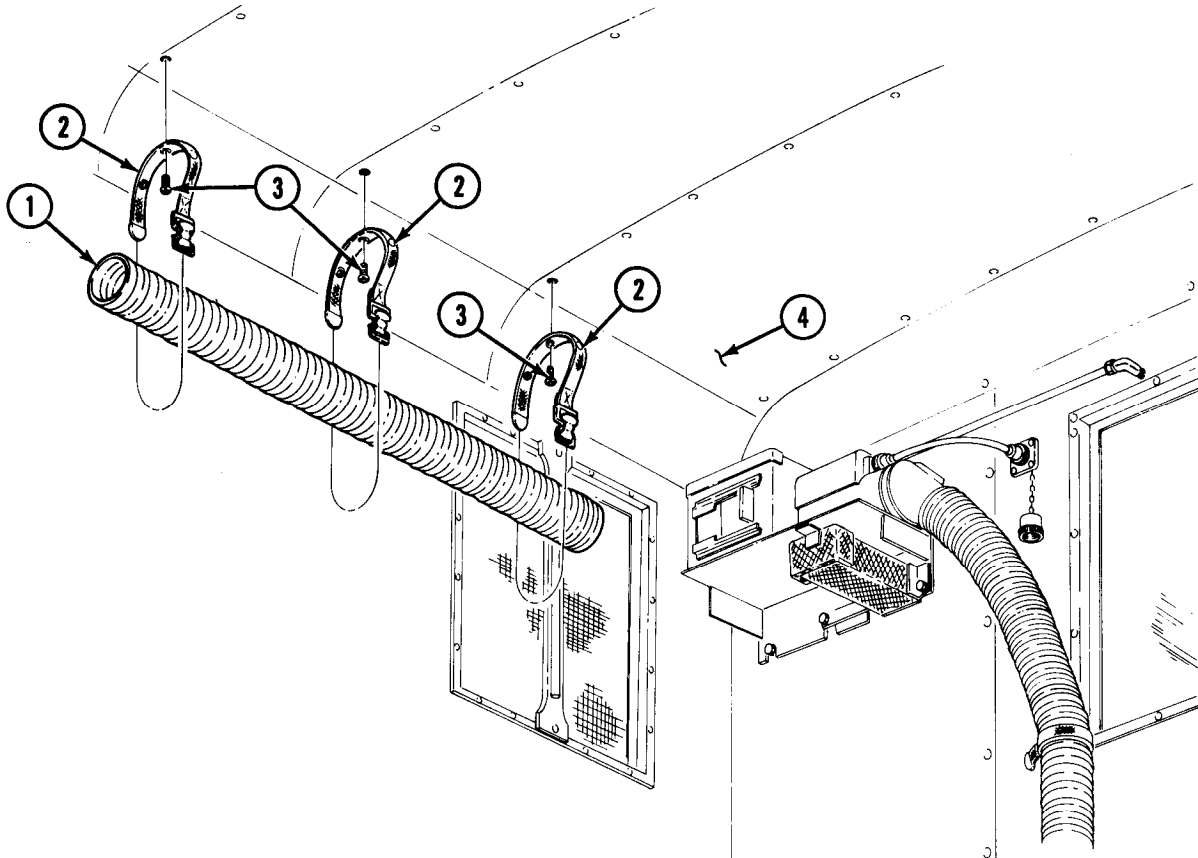

## 14-35. SECONDARY HEATER FUEL LINES REPLACEMENT

This task covers:

### a. Removal

### b. Installation

#### INITIAL SETUP:

##### APPLICABLE MODELS

M109A3 and M185A3

##### MATERIALS/PARTS

Antiseize tape (Appendix C, Item 27)

##### REFERENCES (TM)

TM 9-2320-361-10

TM 9-2320-361-20P

##### EQUIPMENT CONDITION

Parking brake set (TM 9-2320-361-10).

##### GENERAL SAFETY INSTRUCTIONS

Diesel fuel is flammable. Do not perform this procedure near flames.

### a. Removal

#### **WARNING**

Diesel fuel is flammable. Do not perform fuel system procedures near open flame. Injury or death to personnel may result.

#### **NOTE**

Have drainage container ready to catch coolant.

1. Remove tubing (3) from elbow (4) and tee (2).
2. Remove elbow (4) from nipple (5).
3. Remove tubing (1) from tee (2).
4. Remove tee (2) from van body wall (6).

#### **NOTE**

Wrap male pipe threads with antiseize tape prior to installation.

### b. Installation

1. Install tee (2) on van body wall (6).
2. Install tubing (1) on tee (2).
3. Install elbow (4) on nipple (5).
4. Install tubing (3) on elbow (4) and tee (2).

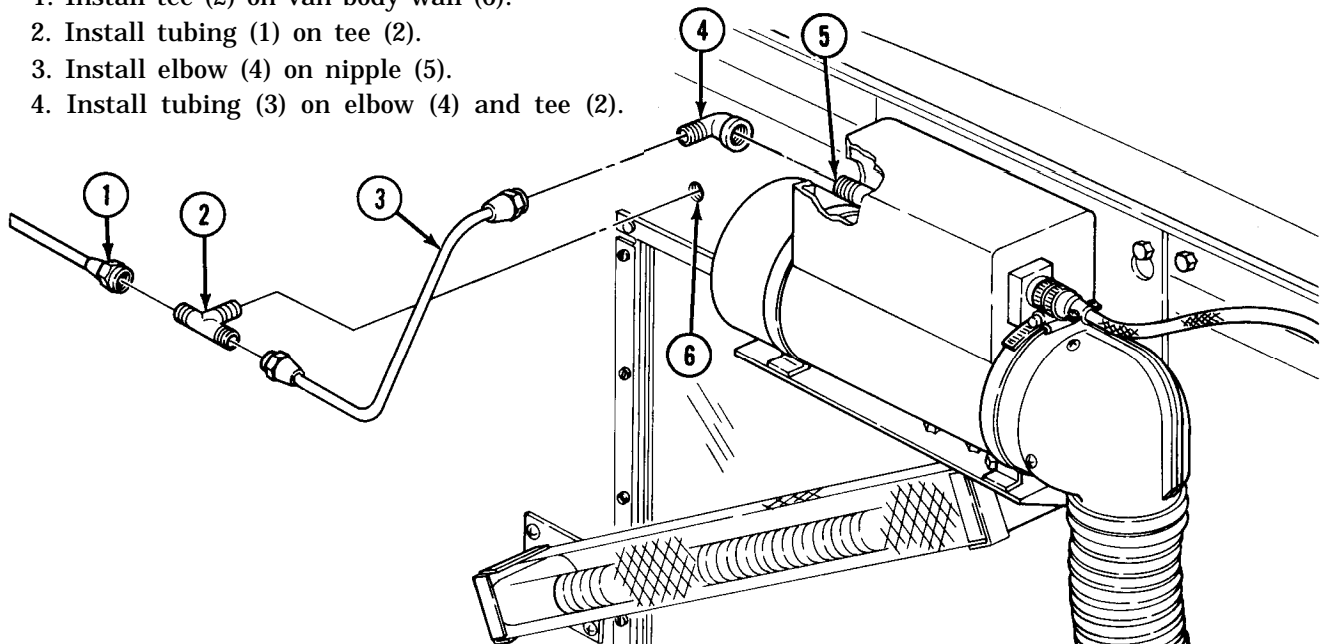

<b>14-36. SECONDARY HEATER AND DUCT REPLACEMENT</b>
---

**This task covers:**

- a. Heater, Exhaust Tube, and Guard Removal**
- b. Duct Removal**

- c. Duct Installation**
- d. Heater, Exhaust Tube, and Guard Installation**

**INITIAL SETUP:**

**APPLICABLE MODELS**

M109A3 and M185A3

**MATERIALS/PARTS**

Twelve lockwashers  
O-ring  
Two gaskets

**REFERENCES (TM)**

TM 9-2320-361-10  
TM 9-2320-361-20P

**EQUIPMENT CONDITION**

Parking brake set (TM 9-2320-361-10).

<b>a. Heater, Exhaust Tube, and Guard Removal</b>
---

1. Disconnect heater harness (7) from heater (3).
2. Remove clamp (10) and duct (13) from adapter (8).
3. Remove eight screws (9) and adapter (8) from heater (3).
4. Remove two clamps (2), heater (3), washer (11), and O-ring (12) from support (14). Discard O-ring (12).
5. Remove screws (16) and (22), lockwasher (23), washer (24), and guard (21) from exhaust tube (20), tube adapter (27), and support (14). Discard lockwasher (23).
6. Remove clamp (26) from exhaust tube (20) and tube adapter (27).
7. Remove three screws (22), lockwashers (23), tube adapter (27), and gasket (28) from van wall (29). Discard lockwashers (23) and gasket (28).
8. Remove four screws (16), gasket (15), and exhaust tube (20) from support (14). Discard gasket (15).
9. Remove two screws (6), lockwashers (25), washers (5), two screws (17), lockwashers (18), washers (19), and support (14) from bracket (1). Discard lockwashers (18) and (25).
10. Remove four screws (6), lockwashers (25), three flat washers (5), clamp (4), and bracket (1) from van wall (29). Discard lockwashers (25).

14-36. SECONDARY HEATER AND DUCT REPLACEMENT (Contd)

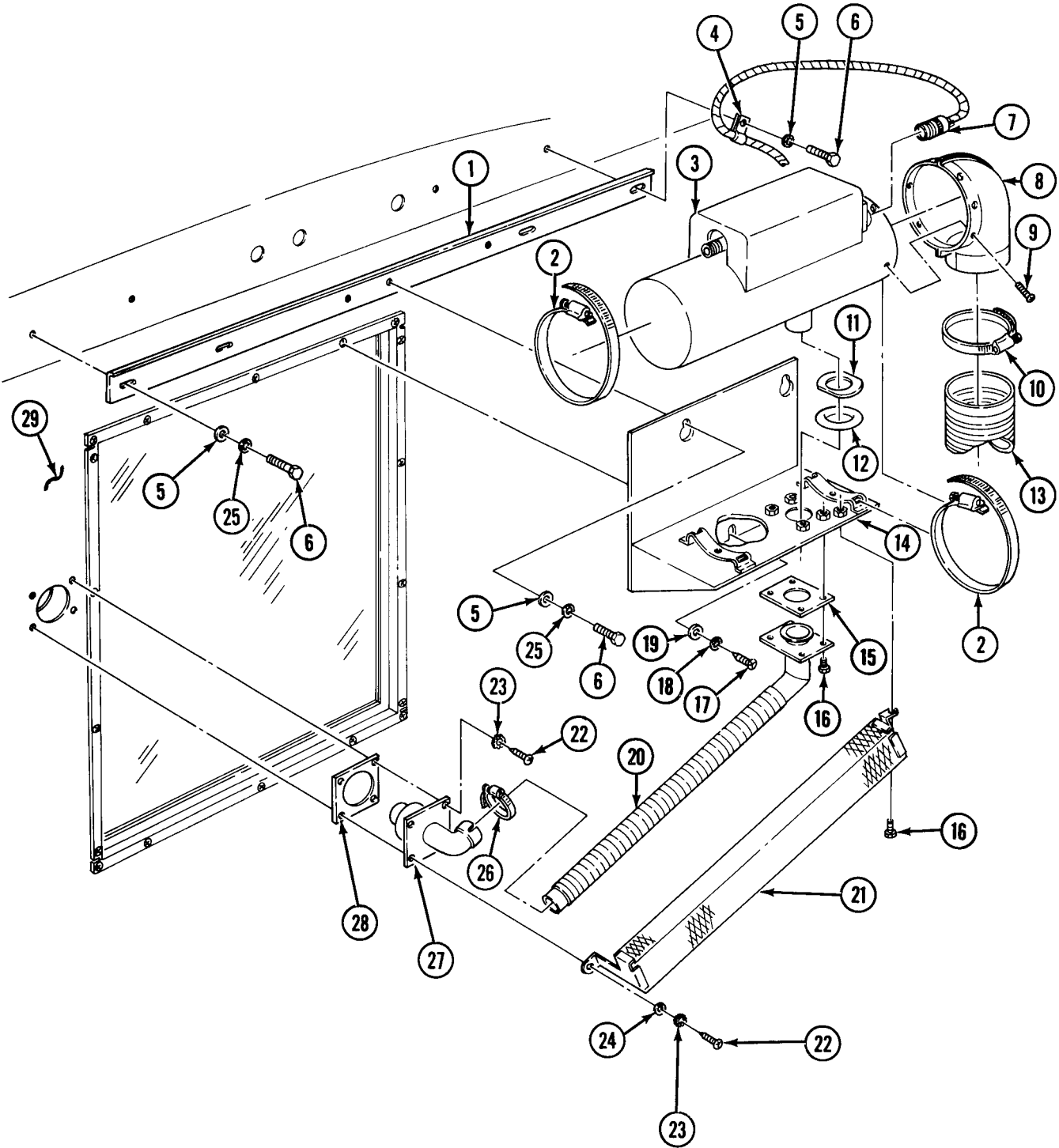

**14-36. SECONDARY HEATER AND DUCT REPLACEMENT (Contd)**

**b. Duct Removal**

1. Unbuckle strap (2) and remove duct (4) from strap (2). Remove screw (3) and strap (2) from van wall (1).
2. Unbuckle strap (7) and remove adapter (6). Remove two screws (8), screw (9), strap (7), and deflector (12) from van wall (1).
3. Remove three screws (10) and deflector (12) from van floor (11).
4. Remove clamp (5) and adapter (6) from duct (4).

**c. Duct Installation**

1. Install adapter (6) and clamp (5) on duct (4).
2. Install deflector (12) on van floor (11) with three screws (10).
3. Install strap (7) and deflector (12) on van wall (1) with two screws (8) and screw (9). Buckle strap (7) on adapter (6).
4. Install strap (2) on van wall (1) with screw (3). Buckle strap (2) on duct (4).

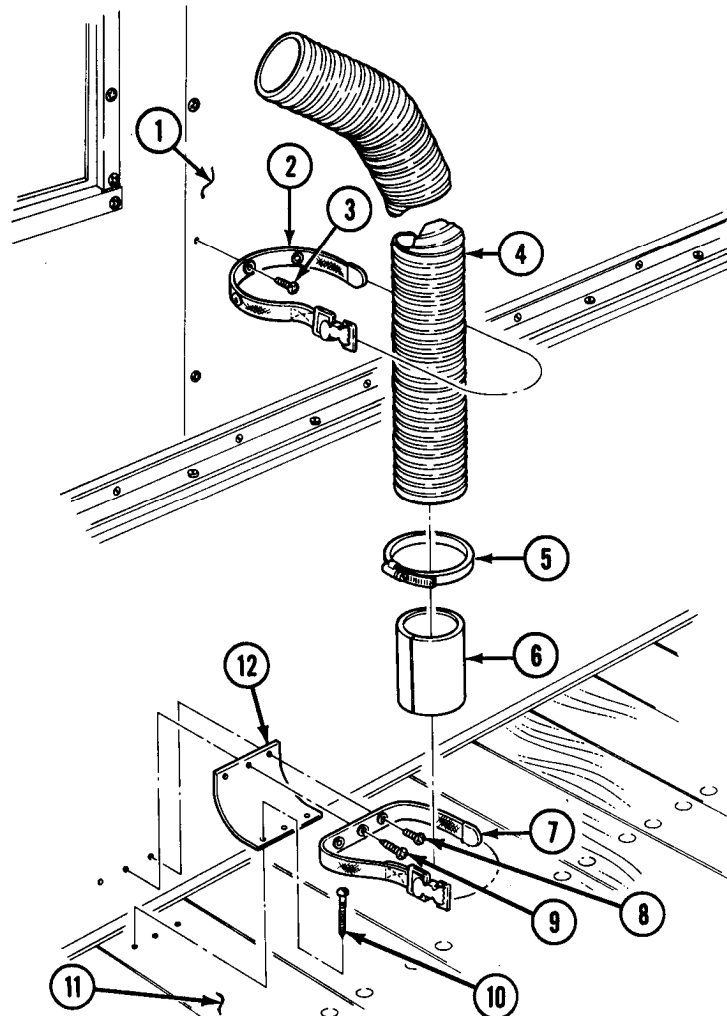

**14-36. SECONDARY HEATER AND DUCT REPLACEMENT (Contd)**

**d. Heater, Exhaust Tube, and Guard Installation**

1. Install bracket (13) on van wall (37) with clamp (16), three washers (38), four new lockwashers (17), and screws (18).
2. Install support (26) on bracket (13) with two washers (38), new lockwashers (17), screws (18), washers (38), new lockwashers (17), and screws (39).
3. Install new gasket (27) and exhaust tube (28) on support (26) with four screws (28).
4. Install new gasket (36) and tube adapter (35) on van wall (37) with three lockwashers (32) and screws (33).
5. Install exhaust tube (29) on tube adapter (35) with clamp (34).
6. Install guard (30) on exhaust tube (29), support (26), and tube adapter (35) with washer (31), new lockwasher (32), and two screws (28) and (33).
7. Install new O-ring (24), washer (23), and heater (15) on support (26) with two clamps (14).
8. Install adapter (20) on heater (15) with eight screws (21).
9. Install duct (25) on adapter (20) with clamp (22).
10. Install heater harness (19) on heater (15).

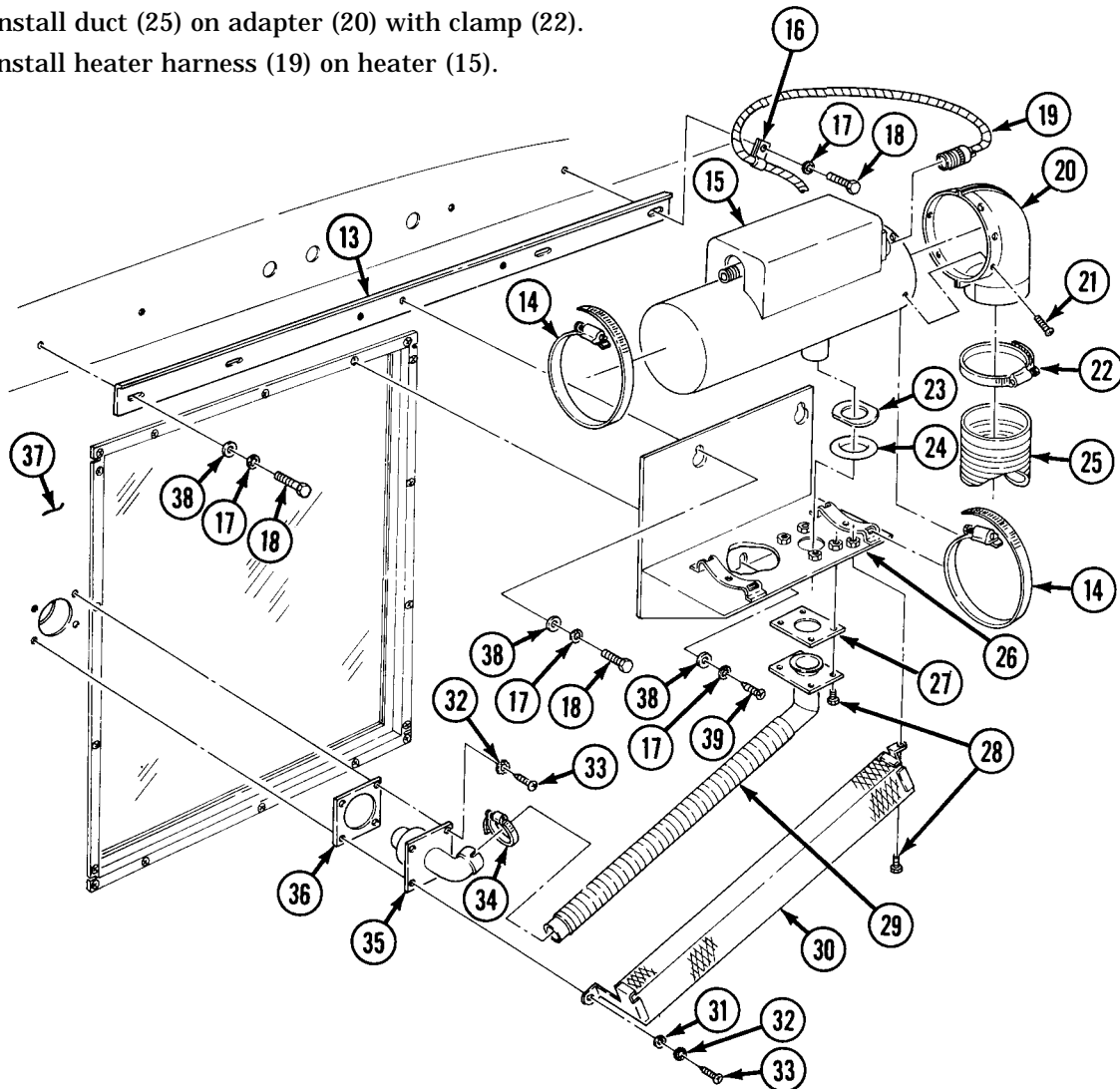



Section III. DEEP WATER FORDING KIT MAINTENANCE

**14-37. DEEP WATER FORDING KIT MAINTENANCE INDEX**

PARA. NO.	TITLE	PAGE NO.
14-38.	Air Intake Tubes Replacement	14-60
14-39.	Control Valve Replacement	14-62
14-40.	Regulator Valve Replacement	14-64

**14-38. AIR INTAKE TUBES REPLACEMENT**

This task covers:

**a. Removal**

**b. Installation**

**INITIAL SETUP:**

APPLICABLE MODELS

All

MATERIALS/PARTS

Eight locknuts  
Tiedown strap

REFERENCES (TM)

TM 9-2320-361-10  
TM 9-2320-361-20P

EQUIPMENT CONDITION

- Parking brake set (TM 9-2320-361-10).
- Hood raised and secured (TM 9-2320-361-10).

**a. Removal**

1. Loosen clamp (18) and remove air tube (19) from air cleaner (2).
2. Loosen three clamps (14) and remove hose (15), elbow (16), and hose (17) from crankcase breather tube (13).
3. Loosen clamp (9) and remove hood (7) and sleeve (8) from air tube (19).
4. Remove four locknuts (12), screws (20), two retaining clamps (11), air tube (19), and hose (17) from supports (10). Discard locknuts (12).
5. Remove four locknuts (22), two supports (10), U-bolt (23), and clamp half (24) from exhaust pipe (21). Discard locknuts (22).
6. Remove tiedown strap (4), loosen two clamps (3), and remove hose (6) from air compressor (1), steering column (5), and air cleaner (2). Discard tiedown strap (4).

**b. Installation**

1. Install hose (6) on air cleaner (2) and air compressor (1). Tighten two clamps (3).
2. Install hose (6) on steering column (5) with new tiedown strap (4).
3. Install two supports (10) on exhaust pipe (21) with U-bolt (23), clamp half (24), and four new locknuts (22).
4. Install hose (17), air tube (19), and two retaining clamps (11) on supports (10) with four screws (20) and new locknuts (12).
5. Install hose (17), elbow (16), and hose (15) on crankcase breather tube (13). Tighten three clamps (14).
6. Install air tube (19) through right side panel and on air cleaner (1) with clamp (18).
7. Install sleeve (8) and hood (7) on air tube (19). Tighten clamp (9).

**14-38. AIR INTAKE TUBES REPLACEMENT (Contd)**

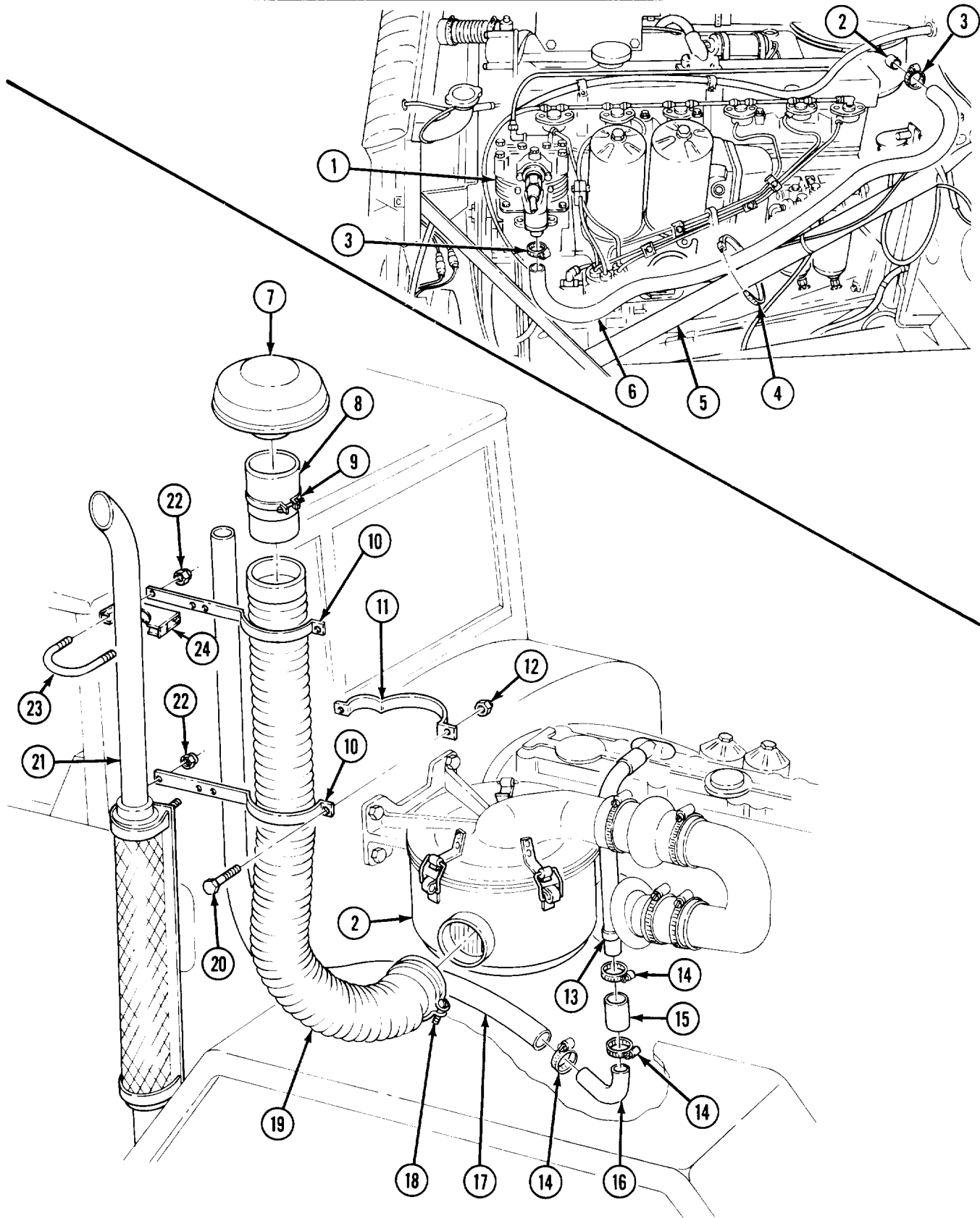

## 14-39. CONTROL VALVE REPLACEMENT

This task covers:

### a. Removal

### b. Installation

#### INITIAL SETUP:

##### APPLICABLE MODELS

All

##### MATERIALS/PARTS

Two locknuts

Antiseize tape (Appendix C, Item 27)

##### REFERENCES (TM)

TM 9-2320-361-10

TM 9-2320-361-20P

##### EQUIPMENT CONDITION

- Parking brake set (TM 9-2320-361-10).
- Air reservoirs drained (TM 9-2320-361-10).

##### GENERAL SAFETY INSTRUCTIONS

Do not disconnect air lines before draining air reservoirs.

#### WARNING

Do not disconnect air lines before draining air reservoirs. Small parts under pressure may shoot out with high velocity, causing injury to personnel.

1. Remove tubes (1) and (3) from elbows (2).
2. Remove two locknuts (8), screws (10), and bracket (5) from instrument panel (9). Discard locknuts (8).
3. Remove two screws (7), plate (6), and bracket (5) from valve (4).
4. Remove two elbows (2) from valve (4).

### **b. Installation**

#### **NOTE**

Wrap male pipe threads with antiseize tape prior to installation.

1. Install two elbows (2) on valve (4).
2. Install bracket (5) and plate (6) on valve (4) with two screws (7).
3. Install bracket (5) on instrument panel (9) with two screws (10) and new locknuts (8).
4. Install tubes (1) and (3) on elbows (2).

14-39. CONTROL VALVE REPLACEMENT (Contd)

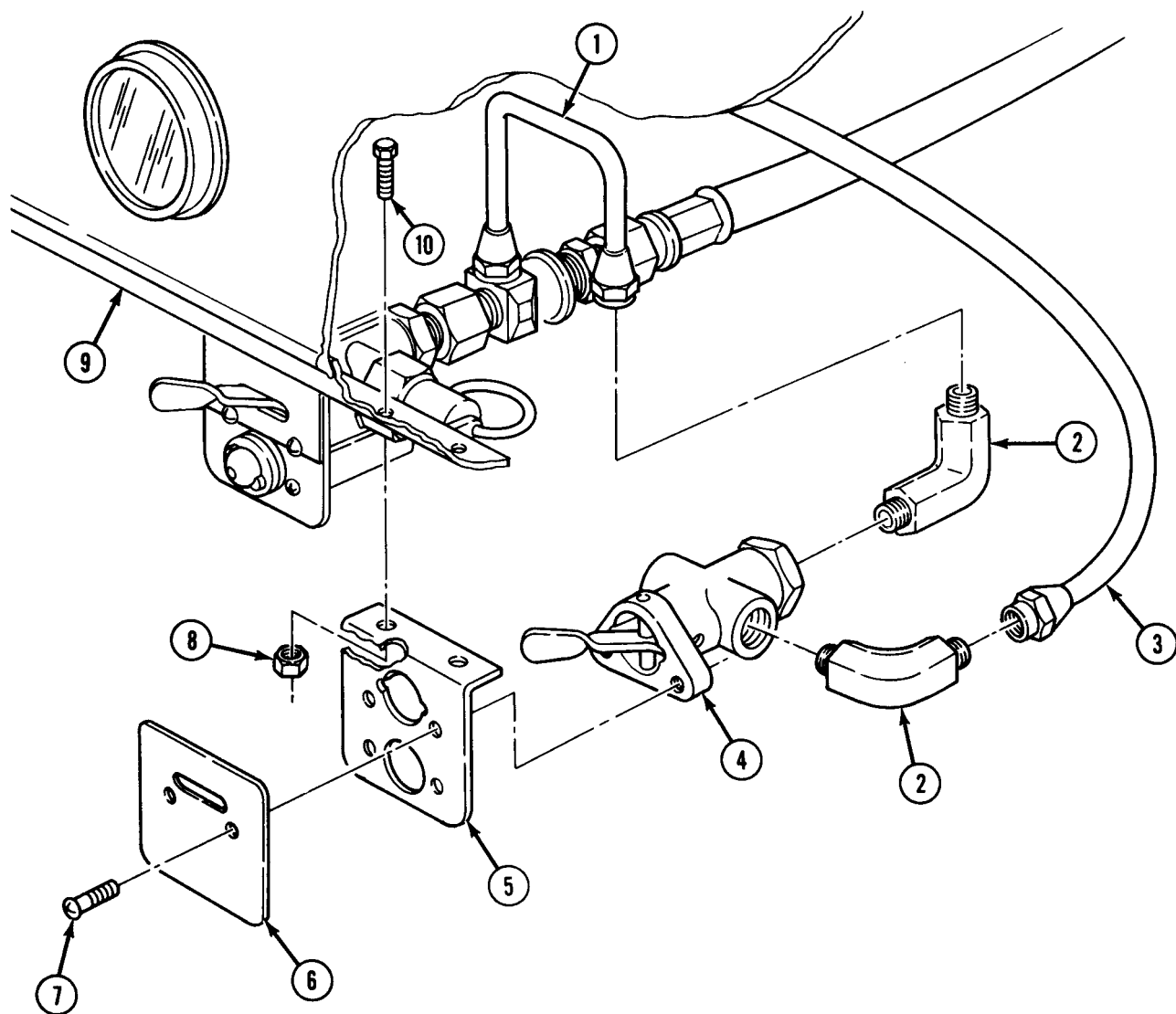

FOLLOW-ON TASK: Start engine (TM 9-2320-361-10) and allow air pressure to build up to normal operating range; check for air leaks at valve.

## 14-40. REGULATOR VALVE REPLACEMENT

This task covers:

### a. Removal

### b. Installation

#### INITIAL SETUP:

##### APPLICABLE MODELS

All

##### MATERIALS/PARTS

Two lockwashers

Antiseize tape (Appendix C, Item 27)

##### REFERENCES (TM)

TM 9-2320-361-10

TM 9-2320-361-20P

##### EQUIPMENT CONDITION

- Parking brake set (TM 9-2320-361-10).
- Air reservoirs drained (TM 9-2320-361-10).

##### GENERAL SAFETY INSTRUCTIONS

Do not disconnect air lines before draining air reservoirs.

### a. Removal

#### WARNING

Do not disconnect air lines before draining air reservoirs. Small parts under pressure may shoot out with high velocity, causing injury to personnel.

1. Remove hose (5) from elbow (4) on engine compartment firewall (1).
2. Remove tube (9) from regulator valve (8).
3. Remove regulator valve (8) from coupling (7).
4. Remove elbow (4), nut (3), lockwasher (2), coupling (7), and lockwasher (6) from firewall (1). Discard lockwashers (2) and (6).

### b. Installation

#### NOTE

Wrap male pipe threads with antiseize tape prior to installation.

1. Install new lockwasher (6), coupling (7), new lockwasher (2), nut (3), and elbow (4) on firewall (1).
2. Install regulator valve (8) on coupling (7).
3. Install tube (9) on regulator valve (8).
4. Install hose (5) on elbow (4).

**14-40. REGULATOR VALVE REPLACEMENT (Contd)**

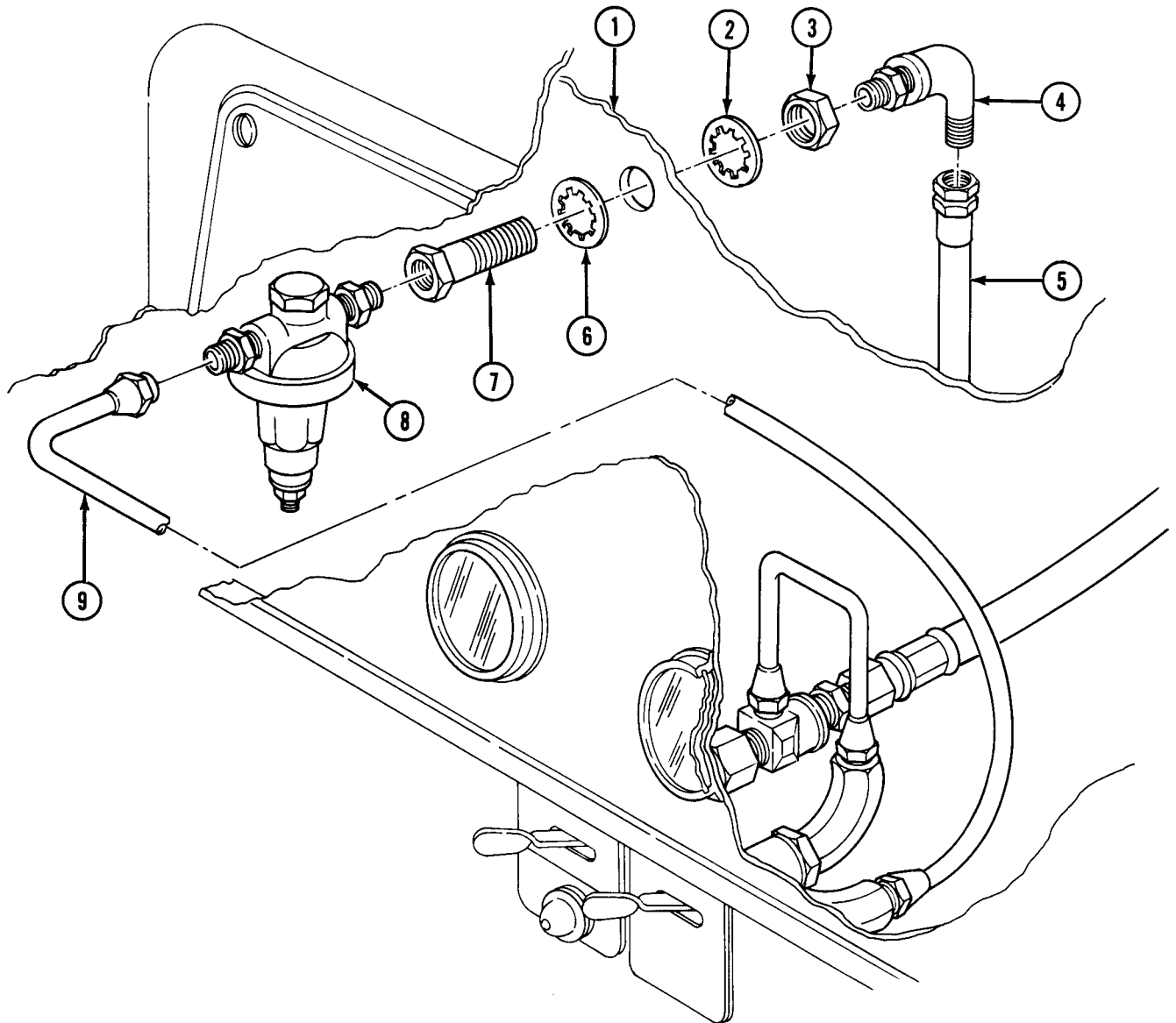

**FOLLOW-ON TASK:** Start engine (TM 9-2320-361-10) and allow air pressure to build up to normal operating range; check for air leaks at valve.

Section IV. A-FRAME KIT MAINTENANCE

**14-41. A-FRAME KIT REPLACEMENT**

This task covers:

- a. Removal
- b. Inspection

c. Installation

**INITIAL SETUP:**

APPLICABLE MODELS

M35A2, M35A2C, M36A2

MATERIALS/PARTS

Lockwasher  
Three locknuts

PERSONNEL REQUIRED

Two

REFERENCES (TM)

TM 9-2320-361-10  
TM 9-2320-361-20P

EQUIPMENT CONDITION

- Parking brake set (TM 9-2320-361-10).
- Front lifting shackle removed, if required, w/winch (para. 10-3) (task c. only).
- Tailgate removed, if required, M35A2, M36A2 (para. 12-3), M35A2C (para. 12-4) (task c. only).

GENERAL SAFETY INSTRUCTIONS

Do not perform this procedure near high voltage wires.

**WARNING**

Vehicle will become charged with electricity if A-frame contacts or breaks high voltage line. Do not attempt to leave vehicle while high voltage line is in contact with A-frame or vehicle. Leaving the vehicle may result in injury to personnel.

**a. Removal**

1. Remove adjusting screw (10) from bottom of each A-frame leg (9) and shackle bracket (11).

**NOTE**

Assistant will help with steps 2 through 4.

2. Push A-frame (12) towards cab (13).
3. Remove cable (4) from pintle hook (5) and lower A-frame (12) to ground.
4. Open snatch block (2) and remove winch cable (3).
5. Remove snatch block (2) from A-frame spreader tube (1).
6. Remove shackle pin (8), cable (4), and harness (7) from shackle (6).
7. Remove locknut (17), lockwasher (16), two washers (15), eyebolt plate (19), and eyebolt (14) from rear cargo bed (18). Discard locknut (17) and lockwasher (16).
8. Remove two locknuts (27), nuts (20), washers (21), harness (7), two spacers (22), spreader tube (1), and two studs (23) from leg extensions (24). Discard locknuts (27).

**14-41. A-FRAME KIT REPLACEMENT (Contd)**

- 9. Remove two pins (26) and leg extensions (24) from A-frame legs (9).
- 10. Remove two pins (25) and A-frame legs (9) from shackle brackets (11).

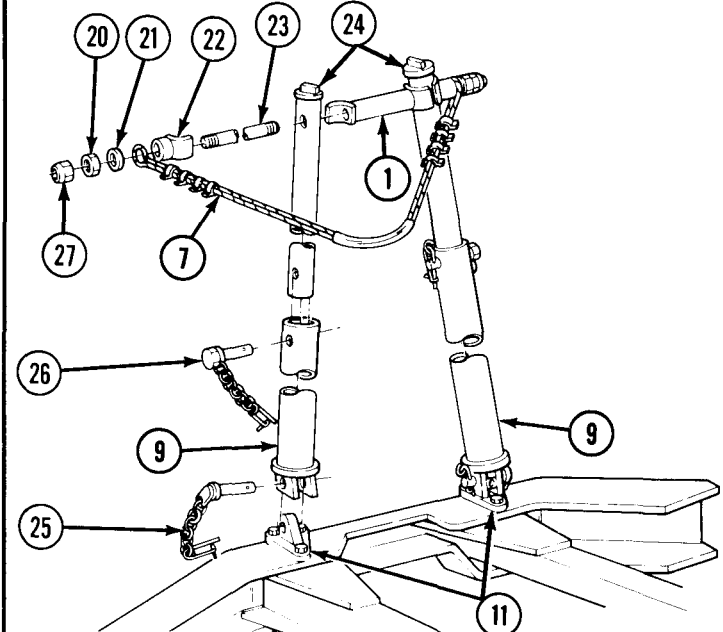
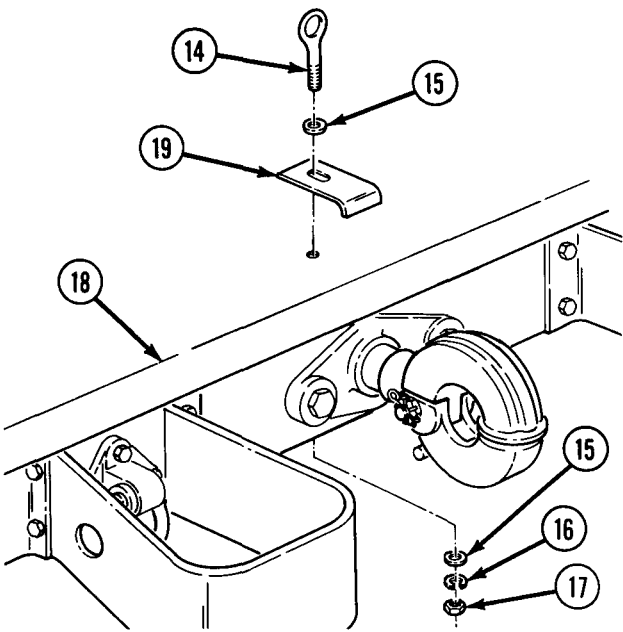
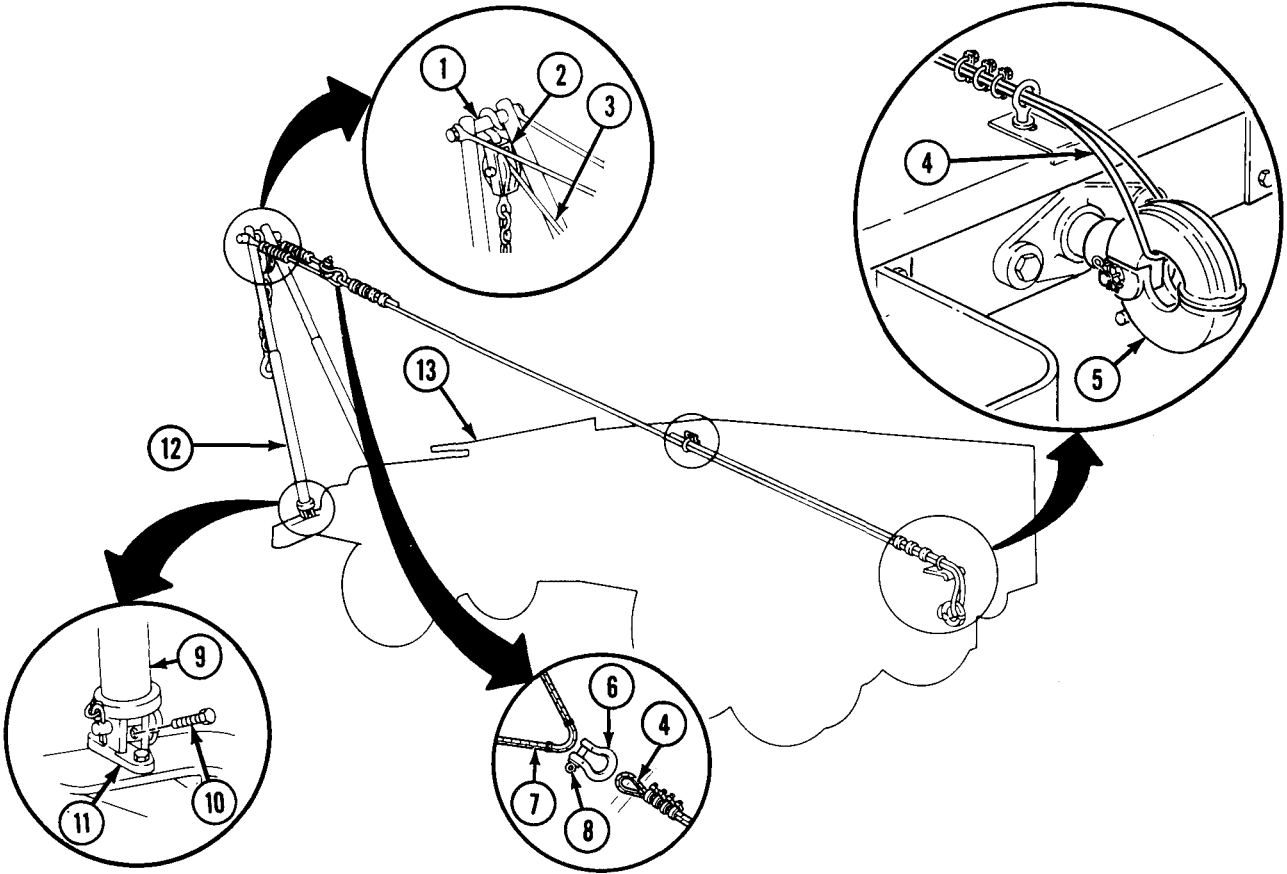



## 14-41. A-FRAME KIT REPLACEMENT (Contd)

### b. Inspection

1. Inspect all metal components for bends, cracks, and breaks. Replace if damaged.
2. Inspect harness (12) and cable (9) for any fraying, breaks, and loose or missing clamps. Repair or replace if necessary.

### c. Installation

#### NOTE

If A-frame kit is not to be installed, proceed to follow-on tasks. Do not continue to next step.

1. Install eyebolt plate (20), washer (16), and eyebolt (7) on rear cargo bed (19).
2. Install washer (16), new lockwasher (17), and new locknut (18) on eyebolt (7).
3. Install two A-frame legs (13) on shackle brackets (15) with two pins (26).
4. Insert two leg extensions (25) into A-frame legs (13), align holes equally, and install with pins (27).
5. Install spreader tube (3) and two spreader tube studs (24) on leg extensions (25). Position spreader tube stud (24) so ends extend equally through holes in leg extensions (25), then install two leg spacers (9), harness (12), two washers (22), nuts (21), and new locknuts (28) on each end of spreader tube studs (24).
6. Install cable (22), harness (12), and shackle pin (11) on shackle (10).
7. Install snatch block (4) on spreader tube (3).
8. Open snatch block (4) and install winch cable (5) on roller, then close snatch block (4).

#### NOTE

Assistant will help with steps 9 and 10.

9. Raise A-frame (1) towards cab (2).
10. Thread cable (9) through eyebolt (7) and install on pintle hook (8).

#### NOTE

A-frame must be angled at approximately 60° from horizontal. Do not insert adjusting screws until all necessary adjustments have been made.

11. Loosen clamp (6) at end of cable (9). Adjust until 60° angle is obtained, then tighten clamp (6).
12. Install adjusting screw (14) on each A-frame leg (13).

#### NOTE

Do not perform follow-on task if A-frame has been installed.



Section V. MOUNTING KIT MAINTENANCE

**14-42. MOUNTING KITS MAINTENANCE INDEX**

PARA. NO.	TITLE	PAGE NO.
14-43.	Machine Gun Mount Kit Replacement	14-70
14-44.	Rifle Mounting Kit Replacement	14-75
14-45.	Decontamination Mounting Kit Replacement	14-76
14-46.	Chemical Agent Alarm Mounting Kit Replacement	14-78
14-47.	Fire Extinguisher Mounting Kit Replacement	14-82
14-48.	Bumper Step Kit Replacement	14-84

**14-43. MACHINE GUN MOUNT KIT REPLACEMENT**

This task covers:

- a. Removal
- b. Disassembly

- c. Assembly
- d. Installation

INITIAL SETUP:

APPLICABLE MODELS

All

MATERIALS/PARTS

Thirty-two locknuts  
Two cotter pins

PERSONNEL REQUIRED

Two

REFERENCES (TM)

TM 9-2320-361-10  
TM 9-2320-361-20P

EQUIPMENT CONDITION

- Parking brake set (TM 9-2320-361-10).
- Cab top removed, hardtop (para. 14-14), or soft top (TM 9-2320-361-10) (task d. only).

GENERAL SAFETY INSTRUCTIONS

Bracket posts must be held in position before removing U-bolts.

**a. Removal**

**NOTE**

Clamp down latch on ring mount to prevent rotation during removal.

1. Remove twelve locknuts (5), screws (2), and twenty-four washers (3) from ring mount (1), adapter (4), front bracket post (6), and rear bracket posts (7) and (8). Discard locknuts (5).

**NOTE**

Assistant will help with steps 2 through 4.

2. Remove ring mount (1) from front bracket post (6), rear bracket posts (7) and (8), and adapter (4).
3. Loosen four screws (13) and remove front bracket post (6) from front gun mount bracket (11). Retighten four screws (13).

**WARNING**

Bracket posts must be held in position before removing U-bolts.  
Failure to do so may cause injury to personnel.

4. Remove eight locknuts (10), four U-bolts (9) and two rear bracket posts (7) and (8) from two rear gun mount brackets (12). Discard locknuts (10).

14-43. MACHINE GUN MOUNT KIT REPLACEMENT (Contd)

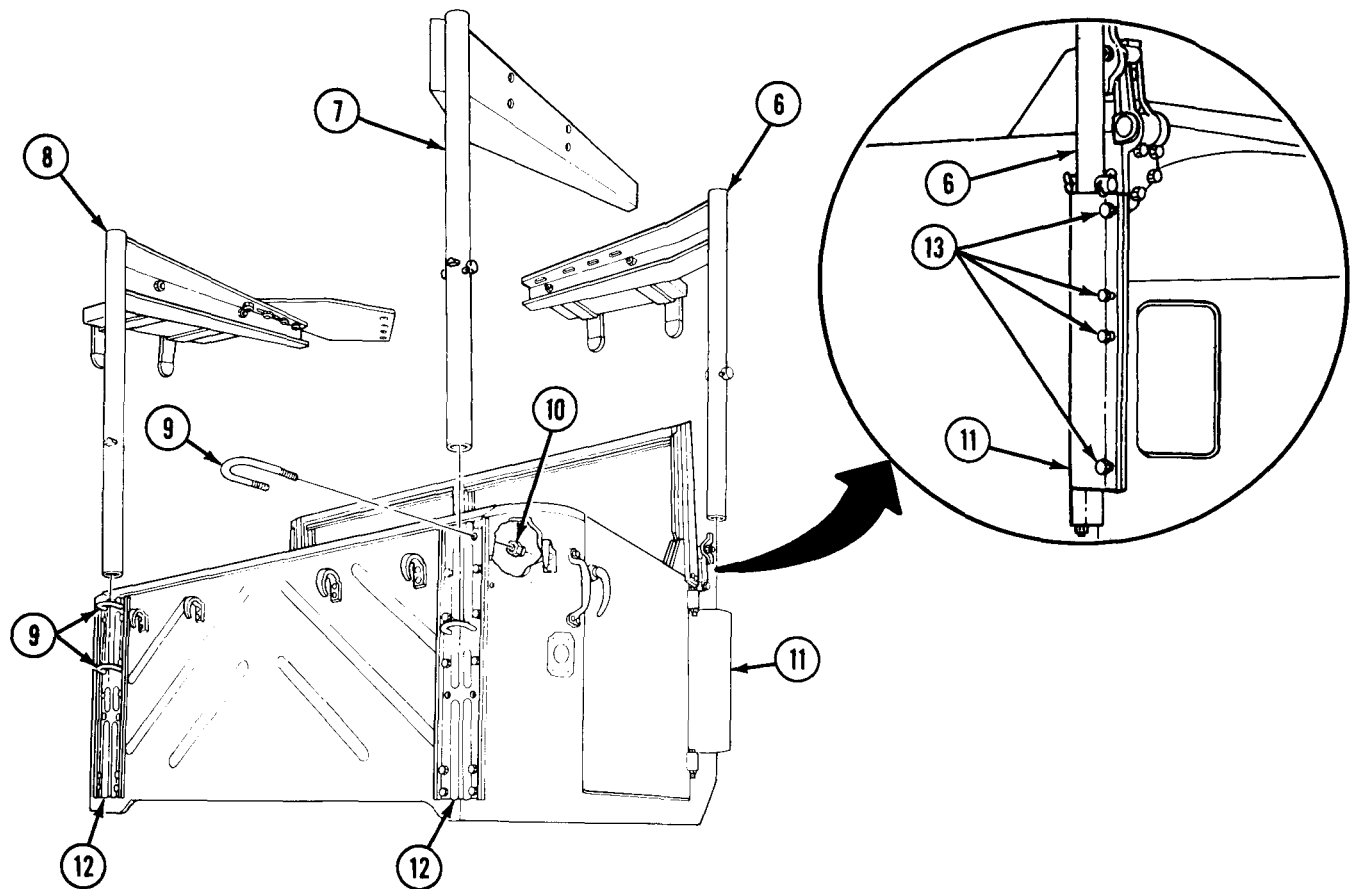
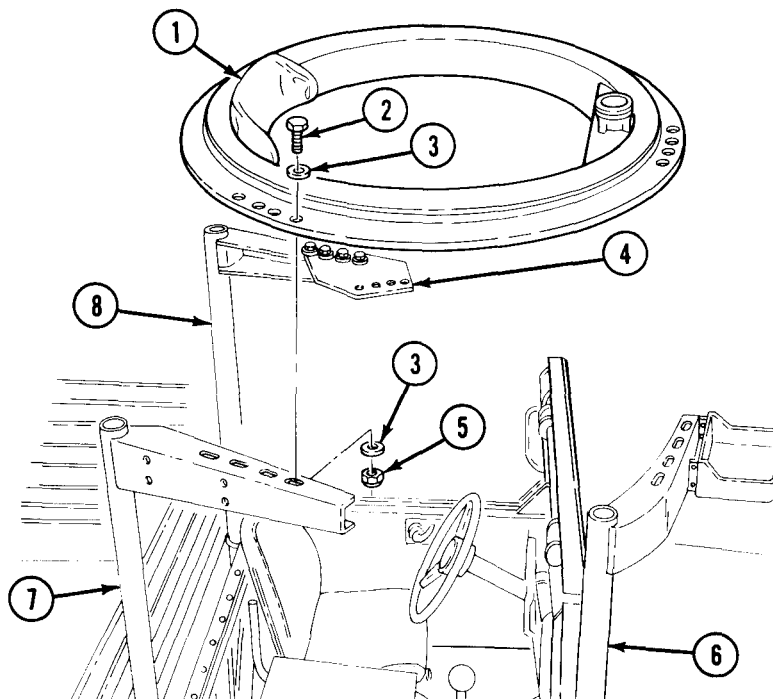

## 14-43. MACHINE GUN MOUNT KIT REPLACEMENT (Contd)

### b. Disassembly

#### NOTE

Steps 1, 2, and 3 are identical for removing ammunition trays from both front bracket post and left rear bracket post. This procedure is for the front bracket post.

1. Remove two straps (6) from ammunition tray (7).
2. Remove four locknuts (1), washers (2), screws (4), and ammunition tray (7) from front bracket post (11). Discard locknuts (1).
3. Remove four locknuts (9), washers (8), screws (10), and two tray brackets (3) from ammunition tray extensions (5). Discard locknuts (9).
4. Remove four locknuts (17), screws (14), eight washers (15), and left rear adapter (16) from left rear bracket post (18). Discard locknuts (17).
5. Remove two cotter pins (13) and straight pins (12) from right rear bracket post (19) and front bracket post (11). Discard cotter pins (13).

### c. Assembly

1. Install left rear adapter (16) on first four holes in left rear bracket post (18) with four screws (14), eight washers (15), and four new locknuts (17). Finger tighten screws (14).
2. Install two straight pins (12) on front bracket post (11) and right rear bracket post (19) with two new cotter pins (13).

#### NOTE

Steps 3, 4, and 5 are identical for assembling ammunition trays on both front bracket post and left rear bracket post. This procedure is for the front bracket post.

3. Install two tray brackets (3) on ammunition tray extensions (5) with four screws (10), washers (8), and new locknuts (9).
4. Install ammunition tray (7) on front bracket post (11) with four screws (4), washers (2), and new locknuts (1).
5. Install two straps (6) on ammunition tray (7).

14-43. MACHINE GUN MOUNT KIT REPLACEMENT (Contd)

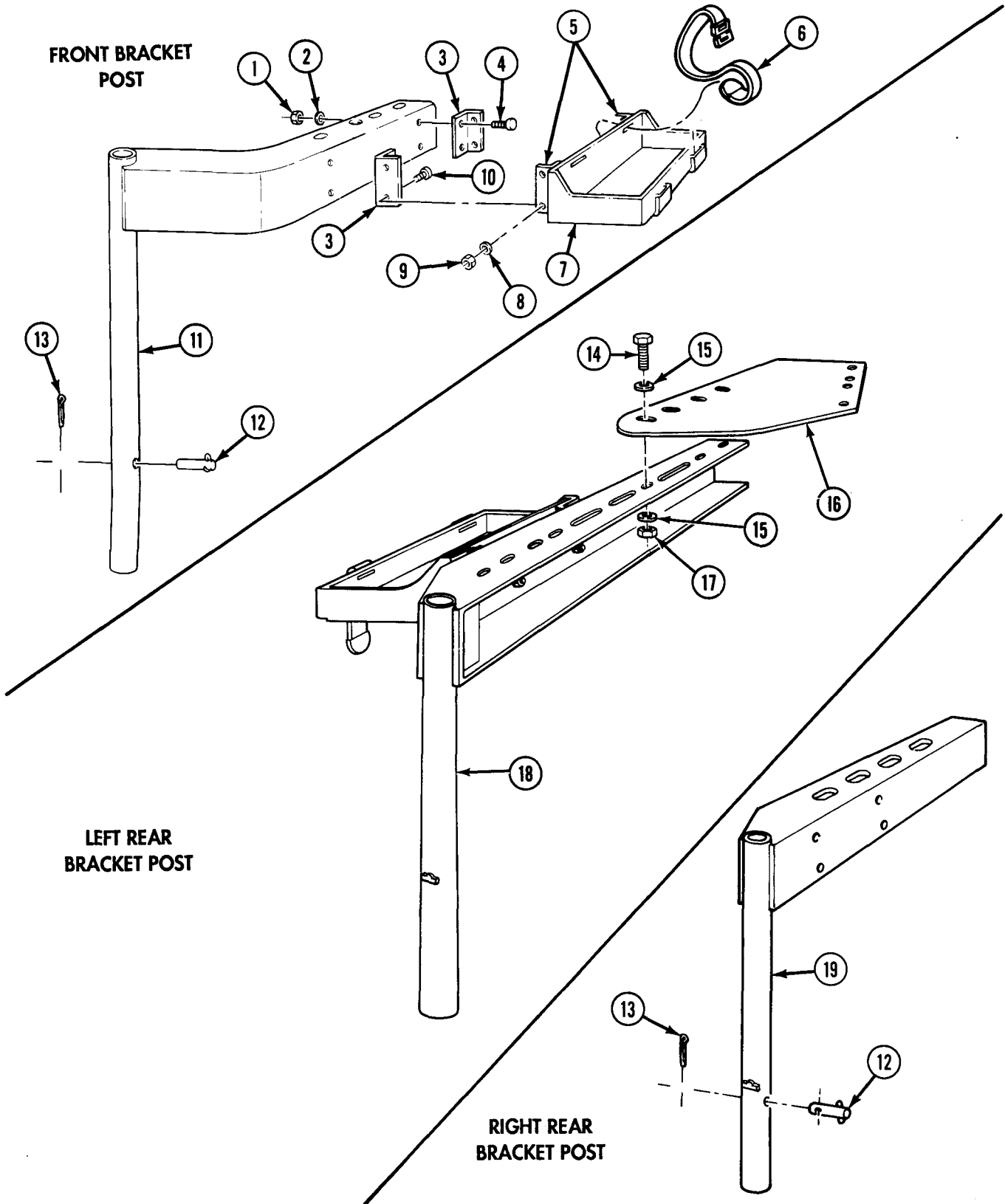

**14-43. MACHINE GUN MOUNT KIT REPLACEMENT (Contd)**

**d. Installation**

**NOTE**

- Assistant will help with steps 2 through 8.
- If machine gun mount kit is not to be installed, proceed to follow-on-task.

1. Install four U-bolts (8) on two rear gun mount brackets (7) with eight new locknuts (3). Finger tighten locknuts (3).
2. Install right rear bracket post (1) through U-bolts (8) and rear gun mount bracket (7). Ensure pin (2) rests on top of U-bolt (8) and bracket post (1) turns freely.
3. Install left rear bracket post (9) through U-bolts (8) and rear gun mount bracket (7). Ensure weld post pin (10) rests on top of U-bolt (8) and bracket post (9) turns freely.
4. Loosen four screws (11) on front gun mount bracket (6).
5. Install front bracket post (4) in front gun mount bracket (6). Ensure pin (5) rests on top of gun mount bracket (6).
6. Position ring mount (12) on front bracket post (4), right rear bracket post (1), and left rear bracket post adapter (15).
7. Aline ring mount locating hole (18) to locating hole in right rear adapter (17).
8. Install ring mount (12) with twelve screws (13), twenty-four washers (14), and twelve new locknuts (16).
9. Tighten all four right front gun mount screws (11).
10. Tighten all remaining gun mount hardware.

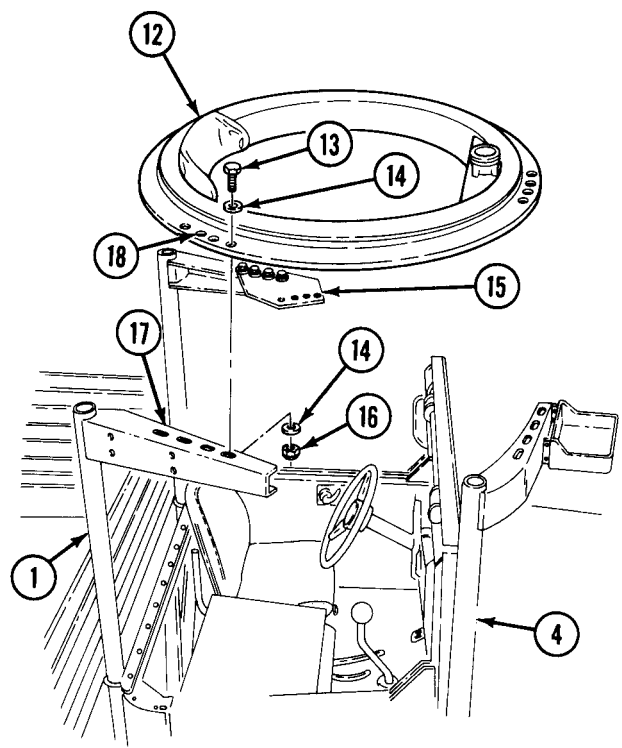
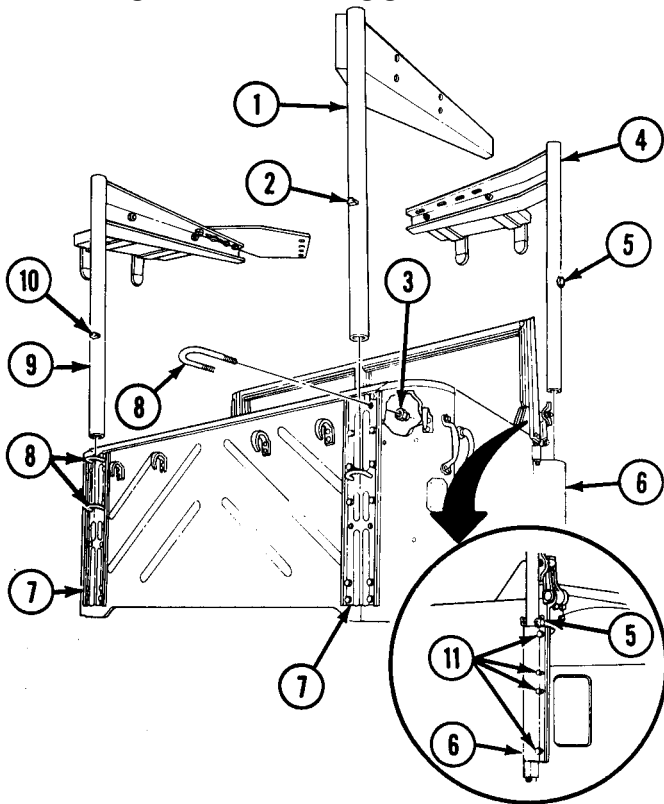

FOLLOW-ON-TASK: Install cab top, hardtop (para. 14-14), or soft top (TM 9-2320-361-10).

## 14-44. RIFLE MOUNTING KIT REPLACEMENT

This task covers:

### a. Removal

### b. Installation

#### INITIAL SETUP:

##### APPLICABLE MODELS

All

##### MATERIALS/PARTS

Eleven locknuts

##### PERSONNEL REQUIRED

Two

##### REFERENCES (TM)

TM 9-2320-361-10

TM 9-2320-361-20P

##### EQUIPMENT CONDITION

Parking brake set (TM 9-2320-361-10).

### a. Removal

1. Remove four locknuts (2), screws (8), two catches (7), and brackets (6) from mounting bracket (5). Discard locknuts (2).
2. Remove three locknuts (3), screws (1), and mounting bracket (5) from instrument panel (4). Discard locknuts (3).

#### NOTE

Assistant will help with step 3.

3. Remove four locknuts (11), screws (9), and two supports (10) from cab floor (12). Discard locknuts (11).

### b. Installation

#### NOTE

Assistant will help with step 1.

1. Install two supports (10) on cab floor (12) with four screws (9) and new locknuts (11).
2. Install mounting bracket (5) on instrument panel (4) with three screws (1) and new locknuts (3).
3. Install two brackets (6) and catches (7) on mounting bracket (5) with four screws (8) and new locknuts (2).

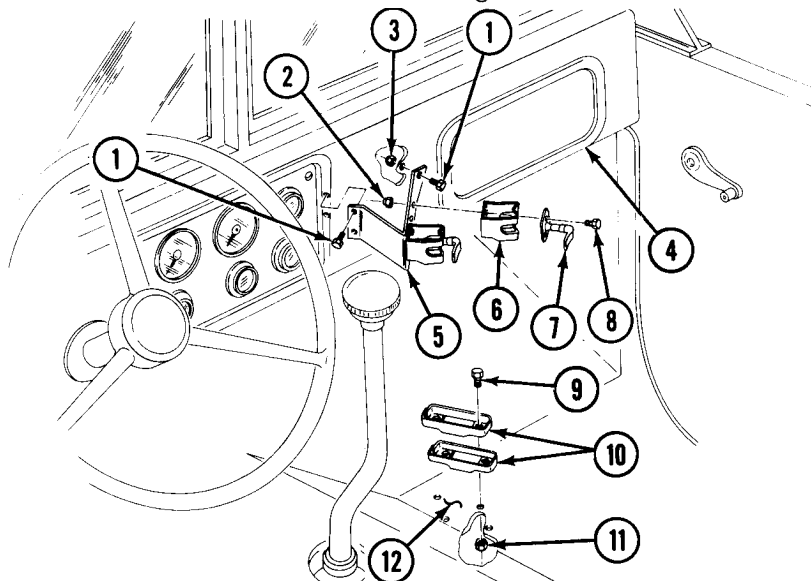



## 14-45. DECONTAMINATION MOUNTING KIT REPLACEMENT

This task covers:

### a. Removal

### b. Installation

#### INITIAL SETUP:

##### APPLICABLE MODELS

All

##### REFERENCES (TM)

TM 9-2320-361-10  
TM 9-2320-361-20P  
TM 3-4230-204-12&P

##### EQUIPMENT CONDITION

- Parking brake set (TM 9-2320-361-10).
- Decontamination apparatus removed (TM 3-4230-204-12&P).

### a. Removal

1. Slide boot (5) up gearshift lever (6).
2. Remove nut (4), screw (2), washer (1), and gearshift lever (6) from transmission stud shaft (3).
3. Remove thirteen screws (8) and intermediate tunnel (7) from cab floor (9).
4. Remove four nuts (12), capscrews (10), and mounting bracket (11) from intermediate tunnel (7).

### b. Installation

1. Install mounting bracket (11) on intermediate tunnel (7) with four capscrews (10) and nuts (12).
2. Install intermediate tunnel (7) on cab floor (9) with thirteen screws (8).
3. Install gearshift lever (6) on transmission stud shaft (3) with washer (1), screw (2), and nut (4).
4. Slide boot (5) down over end of gearshift lever (6).

14-45. DECONTAMINATION MOUNTING KIT REPLACEMENT (Contd)

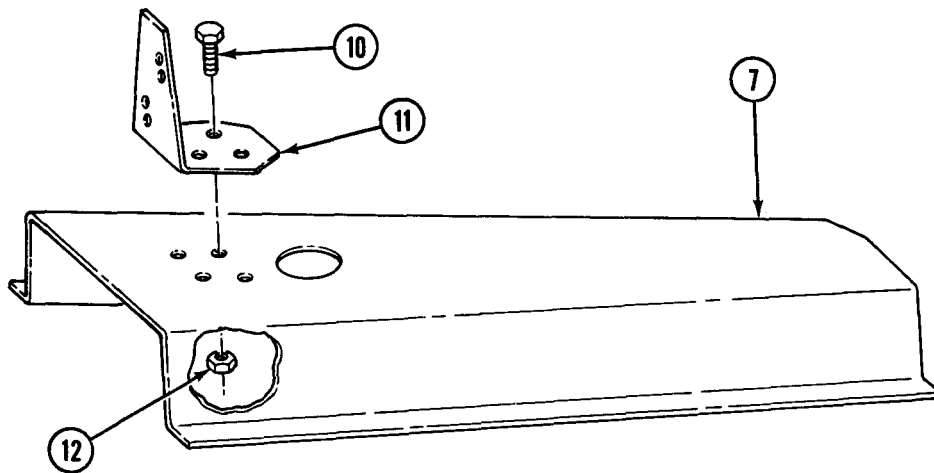
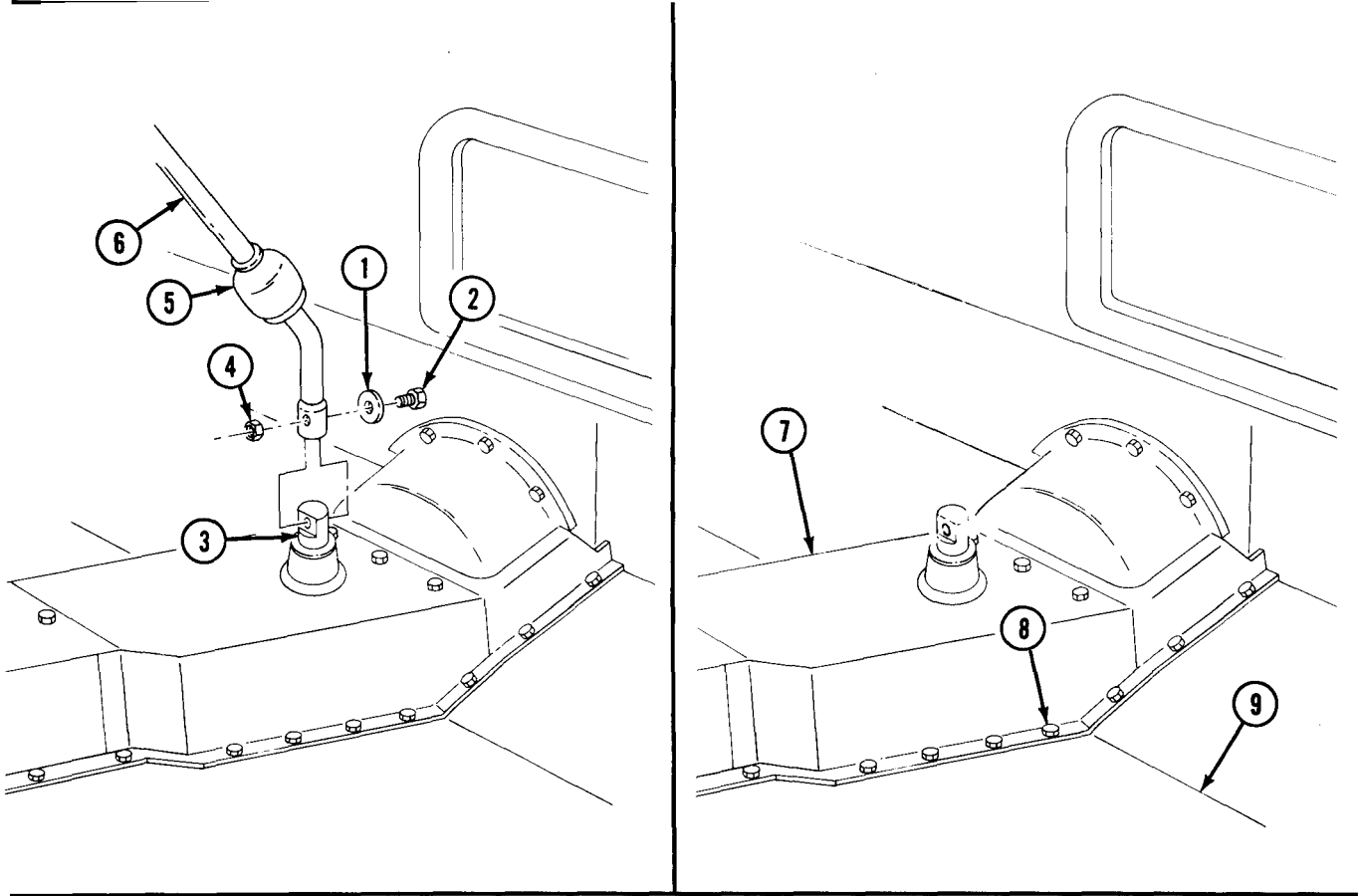

FOLLOW-ON-TASK: Install decontamination apparatus (TM 3-4230-204-12&P)

**14-46. CHEMICAL AGENT ALARM MOUNTING KIT REPLACEMENT**

This task covers:

**a. Removal**

**b. Installation**

**INITIAL SETUP:**

APPLICABLE MODELS

All

MATERIALS/PARTS

Four tiedown straps (Appendix C, Item 20)  
Six locknuts

PERSONNEL REQUIRED

Two

REFERENCES (TM)

TM 3-6665-225-12  
TM 9-2320-361-10  
TM 9-2320-361-20P

EQUIPMENT CONDITION

- Parking brake set (TM 9-2320-361-10).
- Hood raised and secured (TM 9-2320-361-10).
- Battery ground cable disconnected (para. 4-48).
- M43 detector and M42 alarm unit removed (TM 3-6665-225-12).

**a. Removal**

1. Remove nut (3) and harness receptacle (5) from bracket (2).
2. Remove three locknuts (10), support (9), three screws (4), and detector unit bracket (1) from left front fender (8). Discard locknuts (10).
3. Remove screw (6) and clamp (7) from front fender (8).
4. Disconnect wire (16) from connector (17).
5. Remove locknut (11), washer (12), screw (19), harness ground wire (18), ground strap (15), and washer (14) from right side of turn signal flasher box (13). Discard locknut (11).

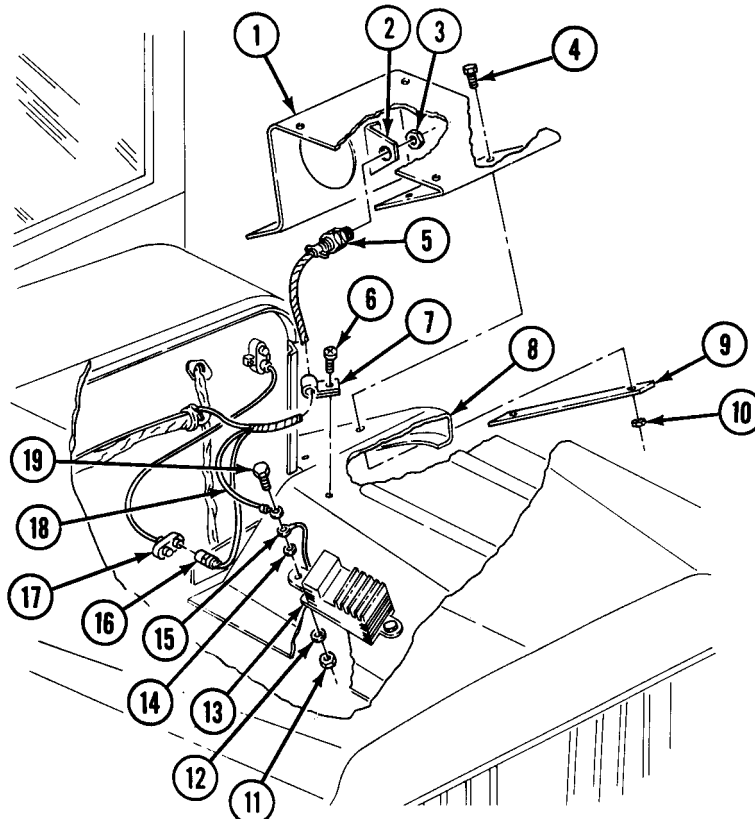

## 14-46. CHEMICAL AGENT ALARM MOUNTING KIT REPLACEMENT (Contd)

6. Remove four tiedown straps (28) from main wiring harness (27). Discard tiedown straps (28).

### NOTE

Assistant will help with steps 7 through 13.

7. Remove nut (31), screw (30), and clamp (29) from firewall (32).
8. Loosen two screws (25) and remove harness (22) from clamps (26).
9. Remove screw (39) and clamp (38) from rear cab panel (20).
10. Remove grommet (37) from cab floor hole (36).
11. Remove two screws (33) and clamps (34) from frame (35).
12. Remove harness (22) from firewall (32).
13. Remove two locknuts (21), screws (24), and alarm unit bracket (23) from rear cab panel (20). Discard locknuts (21).

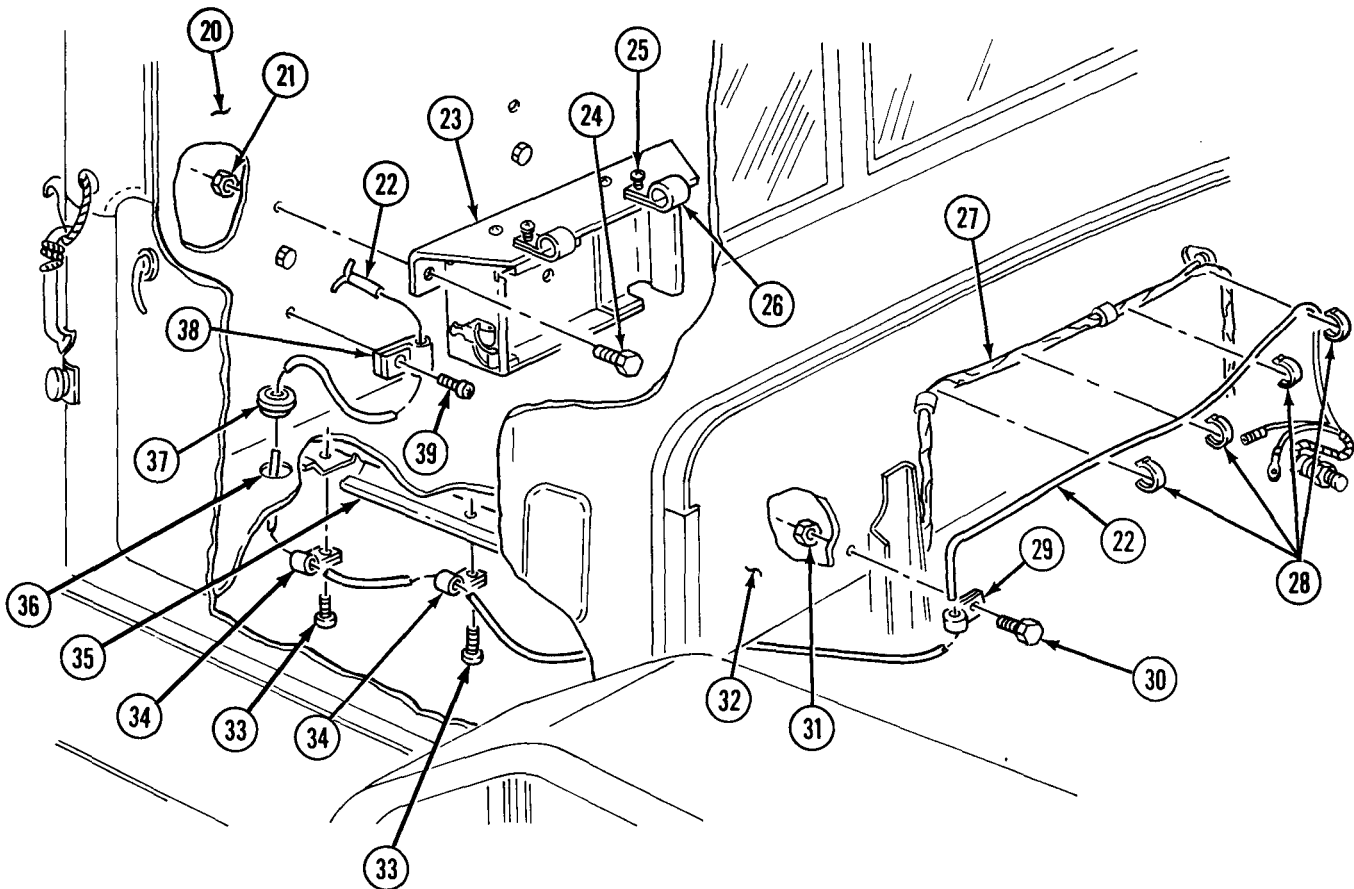

**14-46. CHEMICAL AGENT ALARM MOUNTING KIT REPLACEMENT (Contd)**

**b. Installation**

1. Position detector unit bracket (1) on left front fender (8) and install with three screws (4), support (9), and three new locknuts (10).
2. Install harness receptacle (5) on bracket (2) with nut (3).
3. Install harness (20) on left front fender (8) with clamp (7) and screw (6).
4. Feed harness (20) into engine compartment.
5. Install washer (14), ground strap (15), and harness ground wire (18) on right side of turn signal flasher box (13) with screw (19), washer (12), and new locknut (11).
6. Connect wire (16) to connector (17).
7. Feed harness (20) along main wiring harness (27), under cab, along cab frame (35), and through cab floor hole (36).
8. Position alarm unit bracket (23) on rear cab panel (21) and install with two screws (24) and new locknuts (22).
9. Insert harness (20) through two clamps (26) and tighten screws (25).
10. Install harness (20) on rear cab panel (21) with clamp (38) and screw (39).

**NOTE**

Assistant will help with steps 11 through 14.

11. Insert harness (20) in grommet (37) and install in cab floor hole (36).
12. Install harness (20) on frame (35) with two clamps (34) and screws (33).
13. Install harness (20) on main wiring harness (27) with four new tiedown straps (28).
14. Install harness (20) on firewall (32) with clamp (29), screw (30), and nut (31).

**14-46. CHEMICAL AGENT ALARM MOUNTING KIT REPLACEMENT (Contd)**

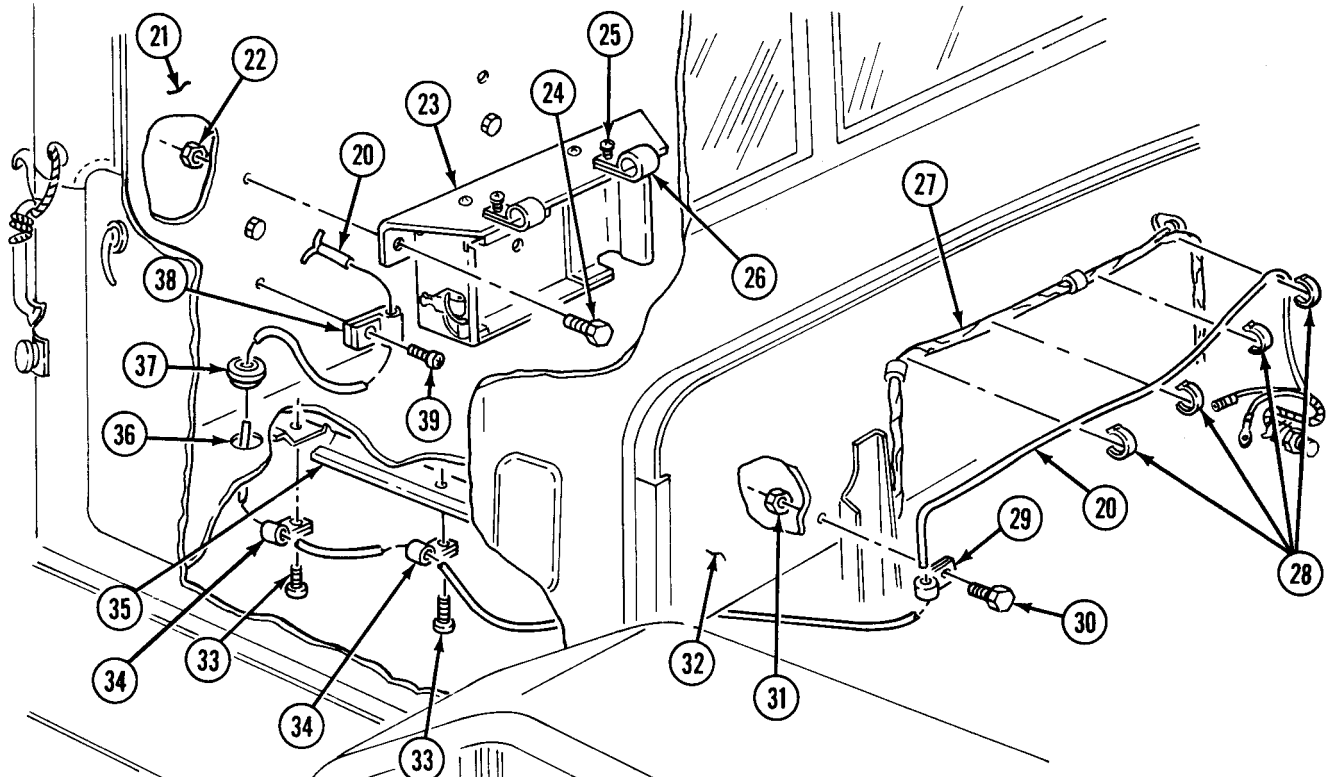
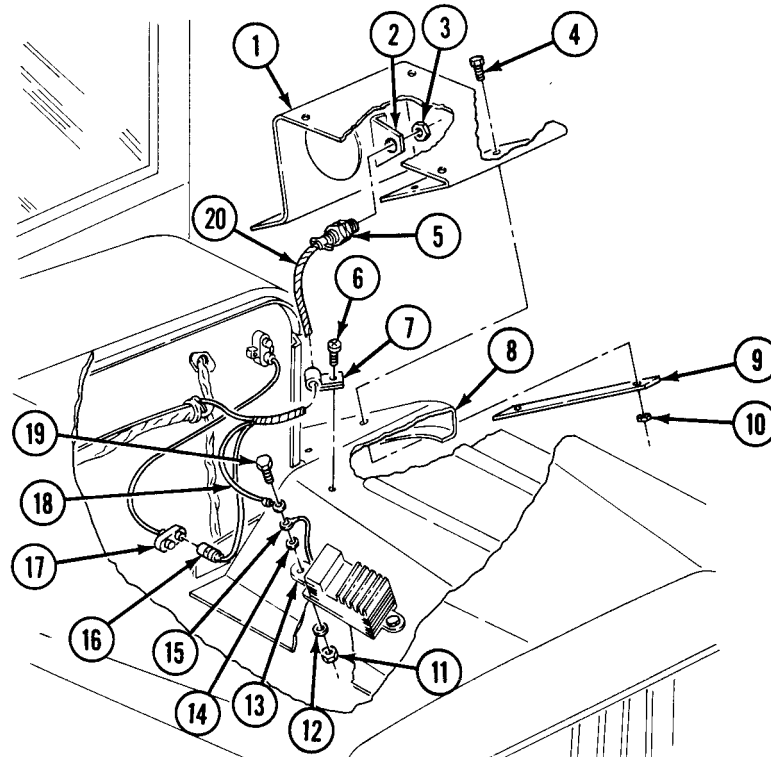

**FOLLOW-ON TASKS:**

- Install M43 detector and M42 alarm unit (TM 3-6665-225-12).
- Connect battery ground cable (para. 4-48).

**14-47. FIRE EXTINGUISHER MOUNTING KIT REPLACEMENT**

This task covers:

**a. Removal**

**b. Installation**

**INITIAL SETUP:**

APPLICABLE MODELS

All

MATERIALS/PARTS

Four locknuts

REFERENCES (TM)

TM 9-2320-361-10

TM 9-2320-361-20P

EQUIPMENT CONDITION

Parking brake set (TM 9-2320-361-10).

**a. Removal**

1. Open two clamps (6), and remove fire extinguisher (8) from mounting bracket (7).
2. Remove four locknuts (3), screws (1), washers (2), and mounting bracket (7) from cab (4). Discard locknuts (3).

**b. Installation**

1. Install mounting bracket (7) on cab (4) with four washers (2), screws (1), and new locknuts (3).
2. Install fire extinguisher (8) on mounting bracket (7) and close two clamps (6).
3. Tighten or loosen adjusting screws (5) to hold fire extinguisher (8) in place.

14-47. FIRE EXTINGUISHER MOUNTING KIT REPLACEMENT (Contd)

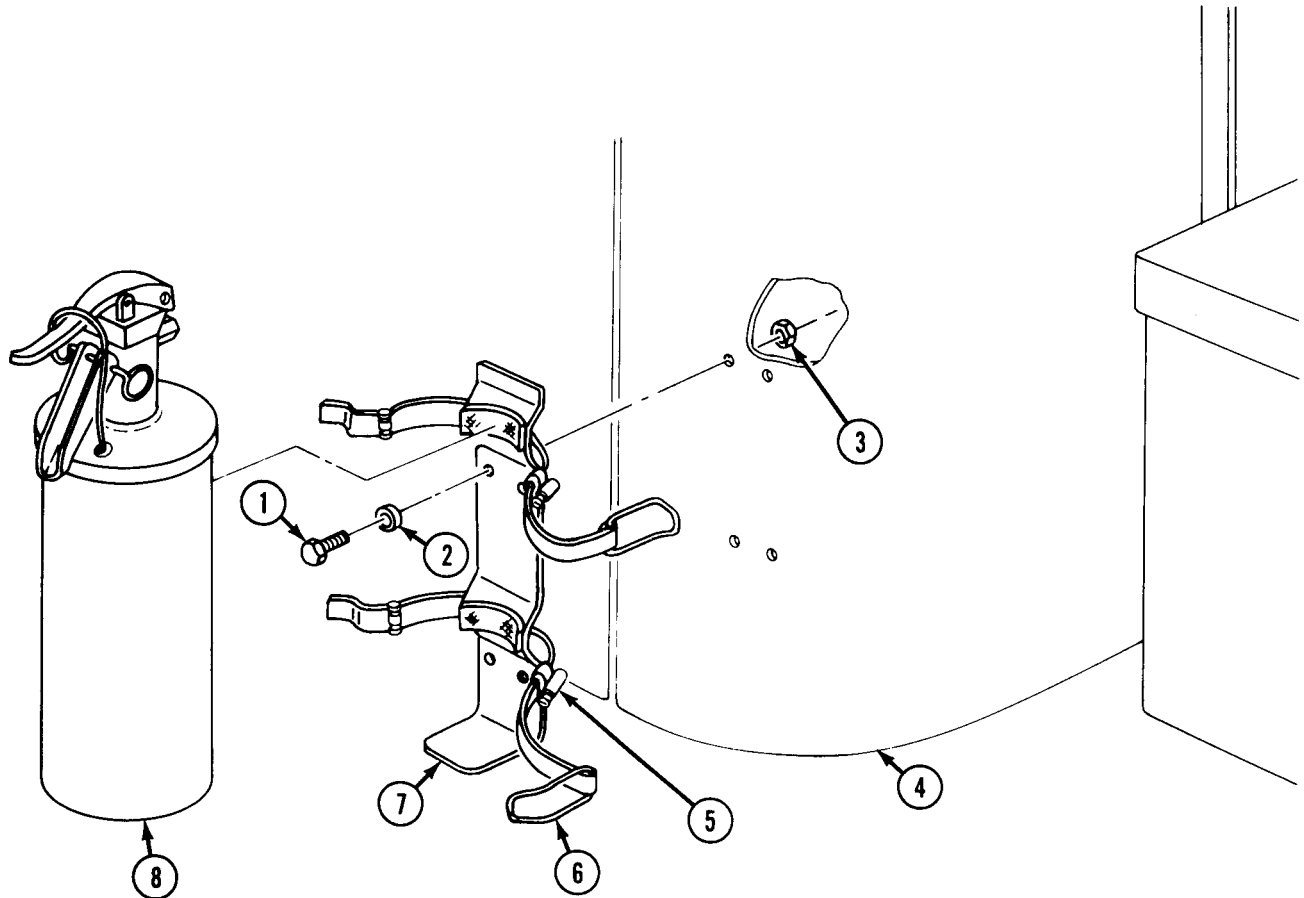



**14-48. BUMPER STEP KIT REPLACEMENT**

This task covers:

**a. Removal**

**b. Installation**

INITIAL SETUP:

APPLICABLE MODELS

All

REFERENCES (TM)

TM 9-2320-361-10

MATERIALS/PARTS

Two lockwashers  
Four locknuts

EQUIPMENT CONDITION

Parking brake set (TM 9-2320-361-10).

**a. Removal**

1. Remove safety pin (8) from pin (11).
2. Remove pin (11) from bumper step (9) and bracket (3).
3. Remove S-hook (10) from bumper step (9).
4. Remove two locknuts (5), lockwashers (6), washers (7), screws (12), and bumper step (9) from bracket (3). Discard lockwashers (6) and locknuts (5).
5. Remove two locknuts (2), screws (4), and bracket (3) from bumper (1). Discard locknuts (2).

**b. Installation**

1. Install bracket (3) on bumper (1) with two screws (4) and new locknuts (2).
2. Install bumper step (9) on bracket (3) with two screws (12), washers (7), new lockwashers (6), and new locknuts (5).
3. Install S-hook (10) on bumper step (9).
4. Install pin (11) on bumper step (9) and bracket (3).
5. Install safety pin (8) in pin (11).

**NOTE**

Ensure step is in stowed position before truck is mobilized.

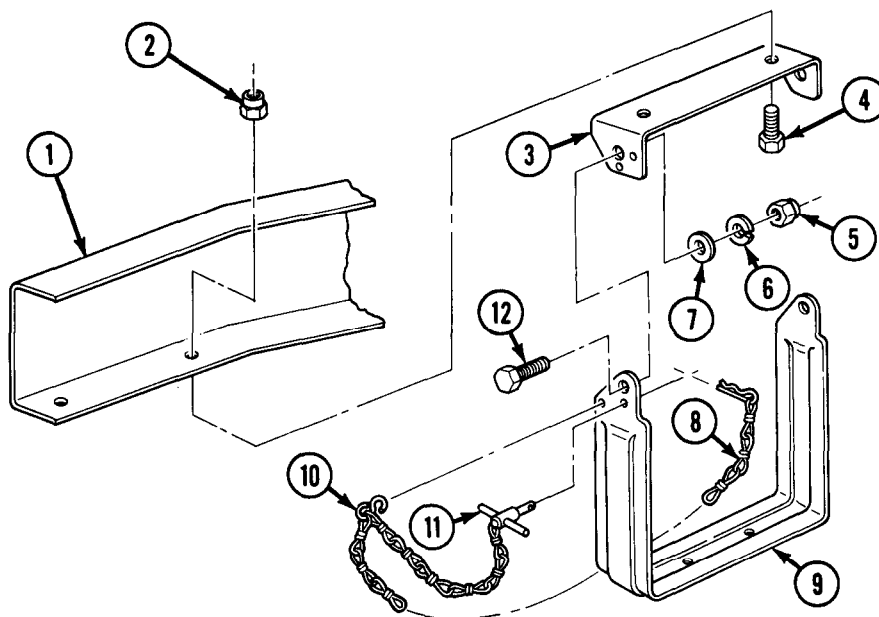

Section VI. 100-AMP ALTERNATOR KIT MAINTENANCE

**14-49. 100-AMP ALTERNATOR KIT MAINTENANCE INDEX**

PARA. NO.	TITLE	PAGE NO.
14-50.	100-Amp Alternator Replacement	14-85
14-51.	100-Amp Alternator Cable and Harness Replacement	14-88
14-52.	100-Amp Alternator Regulator Replacement	14-90

**14-50. 100-AMP ALTERNATOR REPLACEMENT**

**This task covers:**

**a. Removal**

**b. Installation**

**INITIAL SETUP:**

APPLICABLE MODELS

All

MATERIALS/PARTS

Two locknuts  
Four lockwashers

REFERENCES (TM)

TM 9-2320-361-10  
TM 9-2320-361-20P

EQUIPMENT CONDITION

- Parking brake set (TM 9-2320-361-10).
- Hood raised and secured (TM 9-2320-361-10).
- Battery ground cable disconnected (para. 4-48).

## 14-50. 100-AMP ALTERNATOR REPLACEMENT (Contd)

### a. Removal

1. Disconnect harness connector (1) from alternator (12).
2. Loosen screw (13) and nut (5) at adjusting link (2).
3. Loosen two screws (11) and locknuts (8) at alternator mounting bracket (9).
4. Rotate alternator (12) towards engine and remove two drivebelts (7) from pulley (6).
5. Remove screw (13), nut (5), two lockwashers (4), and adjusting link (2) from alternator (12). Discard lockwashers (4).
6. Remove two locknuts (8), screws (11), and lockwashers (10) from alternator mounting bracket (9) and alternator (12). Discard locknuts (8) and lockwashers (10).
7. Remove alternator (12) from alternator mounting bracket (9).

### b. Installation

1. Install alternator (12) on alternator mounting bracket (9) with two new lockwashers (10), screws (11), and new locknuts (8). Finger tighten locknuts (8).
2. Install adjusting link (2) on alternator (12) and stud (3) with two new lockwashers (4), screw (13), and nut (5). Do not tighten nut (5) and screw (13).
3. Place pry bar (14) between the engine and alternator (12). Pull pry bar (14) down until belts (7) appear tight.
4. Place a straight edge (16) across alternator pulley (6) and water pump pulley (15). Check for 0.75 in. (1.905 cm) deflection on alternator belts (7) when pressing down on belts (7).
5. Tighten screw (13) at adjusting link (2) 15-20 lb-ft (20-27 N·m).
6. Tighten nut (5) at adjusting link (2) 25-31 lb-ft (34-42 N·m).
7. Tighten two screws (11) at alternator mounting bracket (9) 33-42 lb-ft (45-57 N·m)
8. Connect harness connector (1) to alternator (12).

14-50. 100-AMP ALTERNATOR REPLACEMENT (Contd)

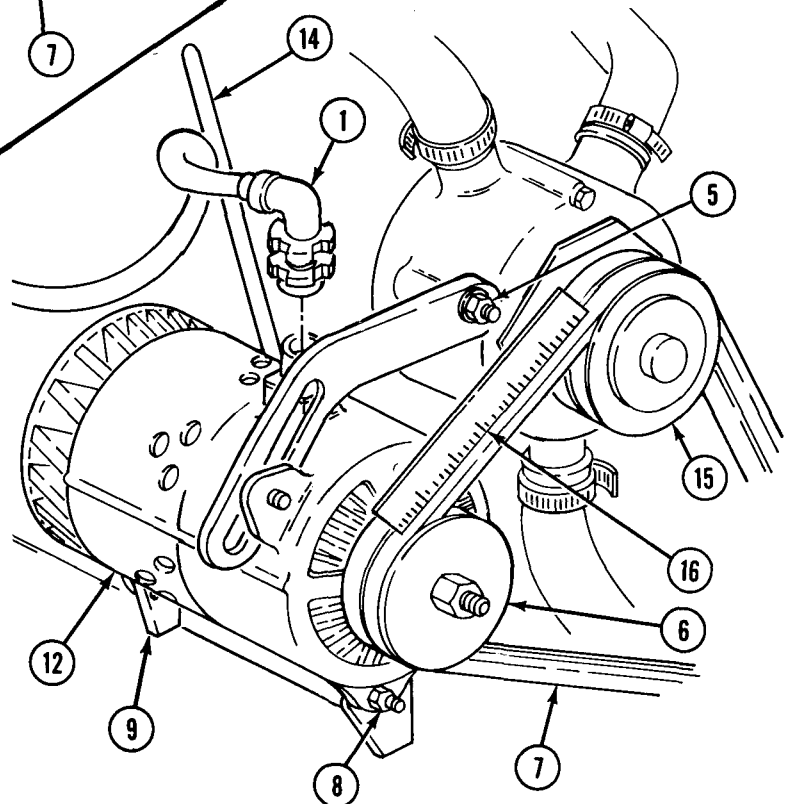
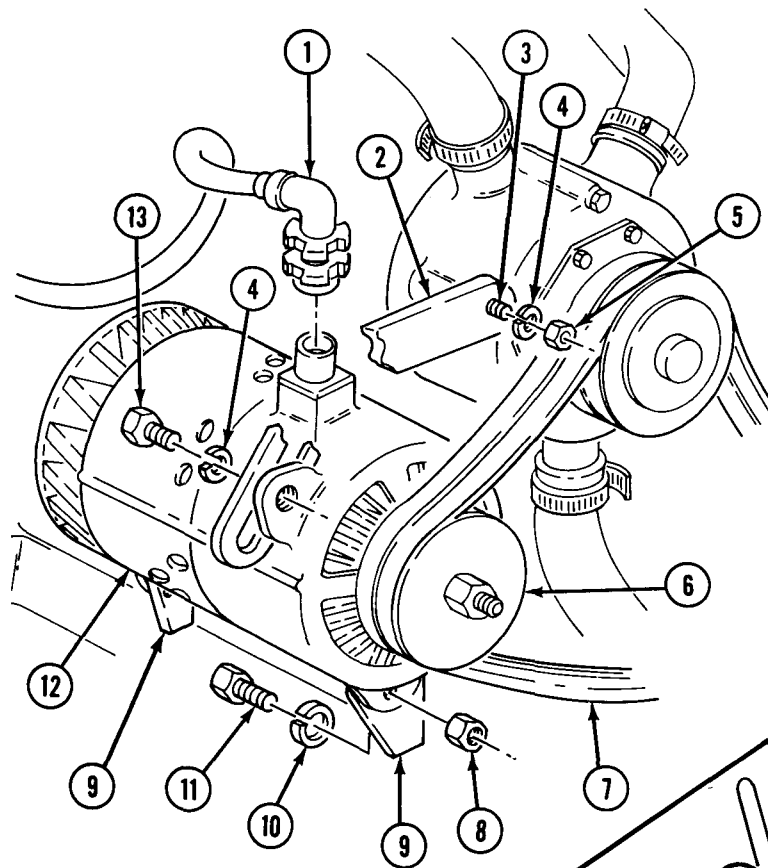

- FOLLOW-ON TASKS:
- Connect battery ground cable (para. 4-48).
  - Start engine and check generator gage operation (TM 9-2320-361-10).

<b>14-51. 100-AMP ALTERNATOR CABLE AND HARNESS REPLACEMENT</b>
--

This task covers:

**a. Removal**

**b. Installation**

**INITIAL SETUP:**

APPLICABLE MODELS

All

MATERIALS/PARTS

Six tiedown straps (Appendix C, Item 20)

REFERENCES (TM)

TM 9-2320-361-10

TM 9-2320-361-20P

EQUIPMENT CONDITION

- Parking brake set (TM 9-2320-361-10).
- Hood raised and secured (TM 9-2320-361-10).
- Battery ground cable disconnected (para. 4-48).

<b>a. Removal</b>
-------------------

1. Remove nut (2), screw (22), and negative cable (3) from negative battery terminal (23).
2. Remove nut (18), screw (20), and positive cable (4) from positive battery terminal (19).
3. Disconnect cable (7) from alternator (15).
4. Remove tiedown strap (17) and cable (7) from oil dipstick tube (16). Discard tiedown strap (17).
5. Disconnect cable (7) from voltage regulator (10).
6. Disconnect harness (8) from voltage regulator (10).
7. Disconnect wire (11) from connector (12).
8. Disconnect wire (14) from connector (13).
9. Remove five tiedown straps (6) from harness (8) and front main wiring harness (5). Discard tiedown straps (6).
10. Remove harness (8) from front main wiring harness (5).

<b>b. Installation</b>
------------------------

1. Connect harness (8) to voltage regulator (10).
2. Insert wire (11) through firewall (9) and connect to connector (12).
3. Connect wire (14) to connector (13).
4. Feed harness (8) along front main wiring harness (5) under cab (1) and onto battery box (21).
5. Connect cable (7) to voltage regulator (10) and alternator (15).
6. Install cable (7) on oil dipstick tube (16) with new tiedown strap (17).
7. Install harness (8) on front main wiring harness (5) with five new tiedown straps (6).
8. Install positive cable (4) on positive battery terminal (19) with screw (20) and nut (18).
9. Install negative cable (3) on negative battery terminal (23) with screw (22) and nut (2).

**14-51. 100-AMP ALTERNATOR CABLE AND HARNESS REPLACEMENT (Contd)**

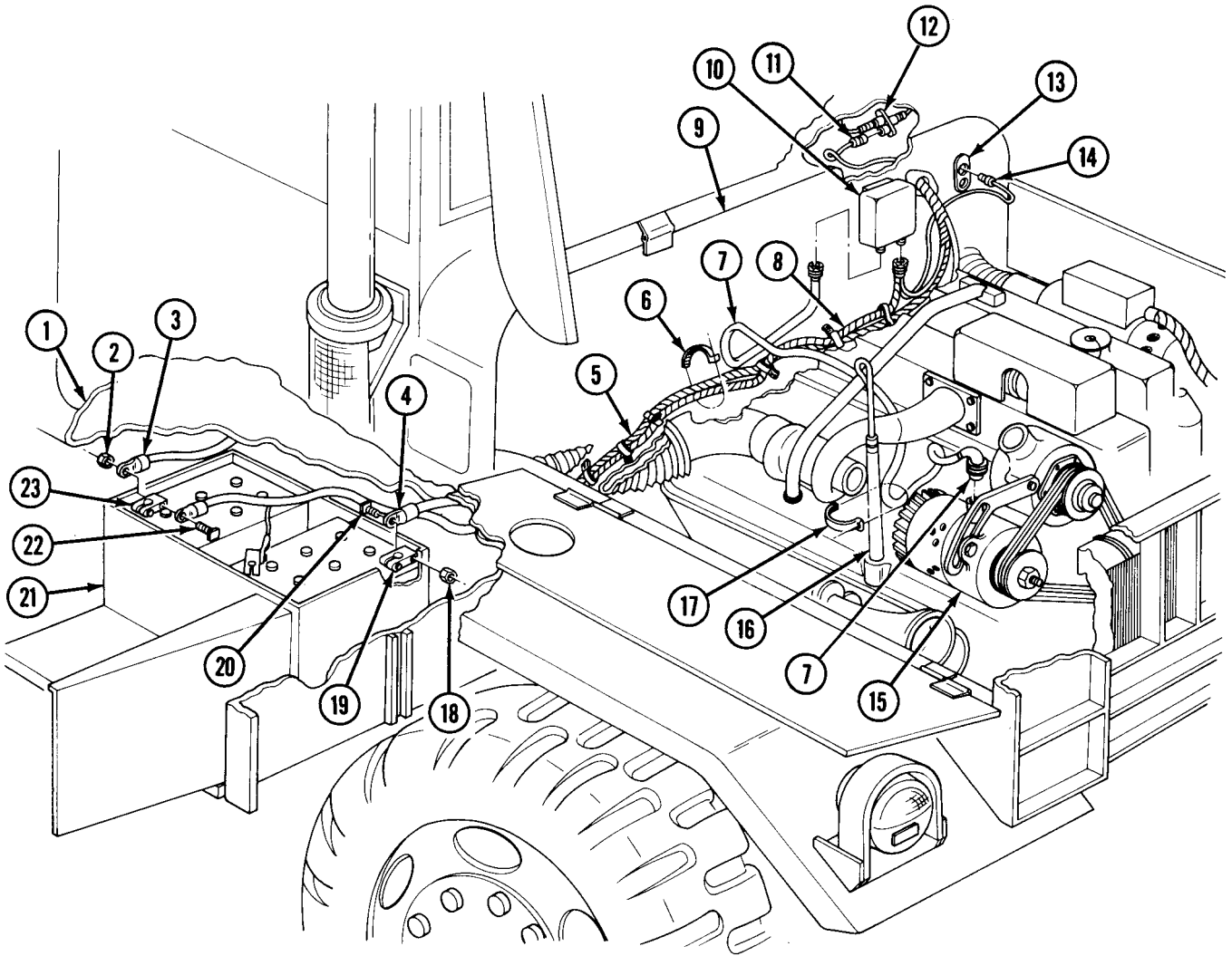

FOLLOW-ON TASK: Connect battery ground cable (para. 4-48).

**14-52. 100-AMP ALTERNATOR REGULATOR REPLACEMENT**

This task covers:

**a. Removal**

**b. Installation**

**INITIAL SETUP:**

APPLICABLE MODELS

All

MATERIALS/PARTS

Eight lockwashers  
Four locknuts

PERSONNEL REQUIRED

Two

REFERENCES (TM)

TM 9-2320-361-10  
TM 9-2320-361-20P

EQUIPMENT CONDITION

- Parking brake set (TM 9-2320-361-10).
- Hood raised and secured (TM 9-2320-361-10).
- Battery ground cable disconnected (para. 4-48).

**a. Removal**

1. Disconnect cable (13) and harness (12) from regulator (11).
2. Remove four nuts (10), lockwashers (9), and regulator (11) from two mounts (3). Discard lockwashers (9).
3. Remove four screws (2), lockwashers (1), and two brackets (8) from regulator (11). Discard lockwashers (1).

**NOTE**

Assistant will help with step 4.

4. Remove four locknuts (6), washers (5), screws (7), and two mounts (3) from firewall (4). Discard locknuts (6).

**b. Installation**

**NOTE**

Assistant will help with step 1.

1. Install two mounts (3) on firewall (4) with four screws (7), washers (5), and new locknuts (6).
2. Install two brackets (8) on regulator (11) with four new lockwashers (1) and screws (2).
3. Install regulator (11) on two mounts (3) with four new lockwashers (9) and nuts (10).
4. Connect cable (13) and harness (12) to regulator (11).

14-52. 100-AMP ALTERNATOR REGULATOR REPLACEMENT (Contd)

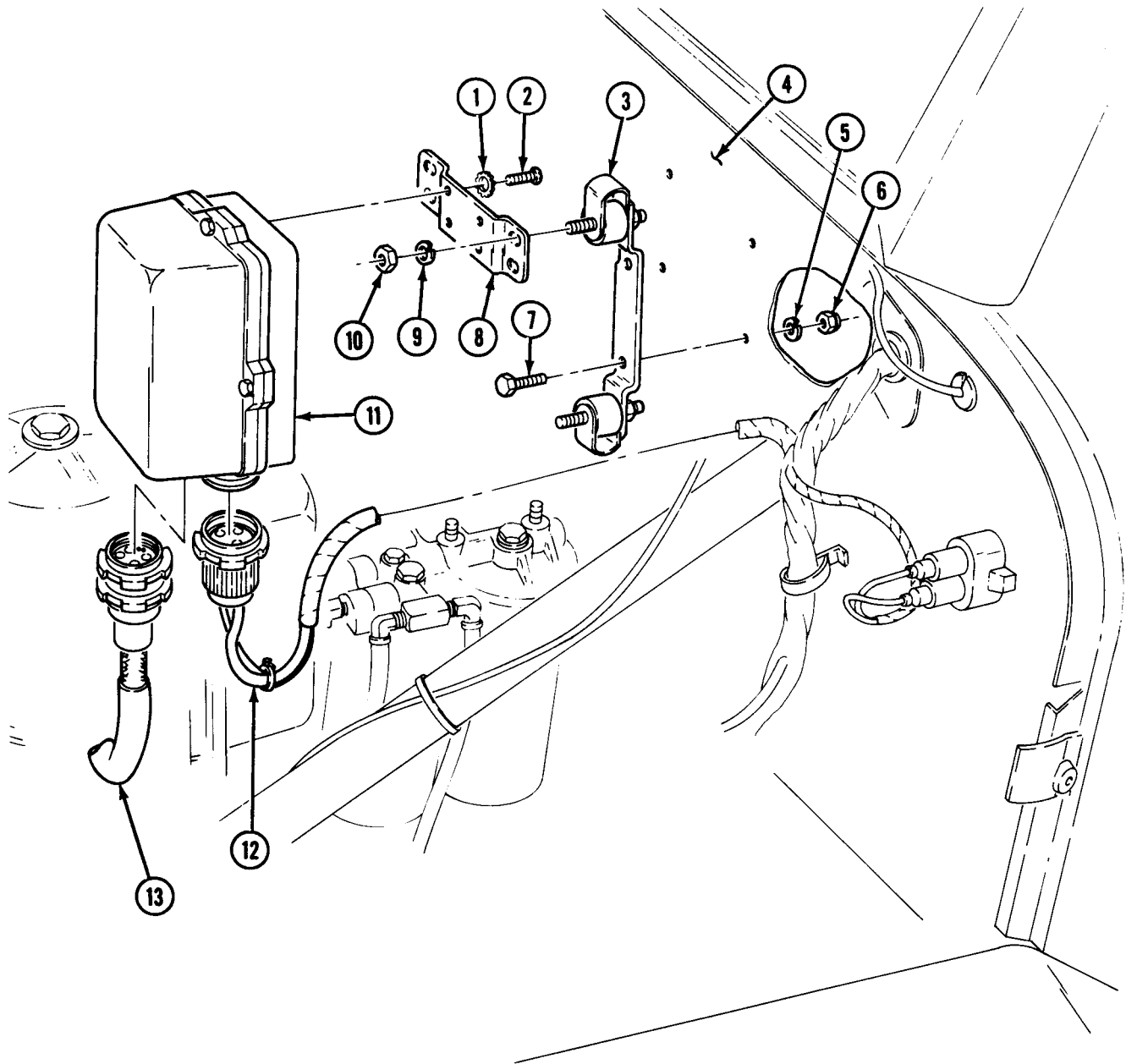

FOLLOW-ON TASK: Connect battery ground cable (para. 4-48).



Section VII. TROOP SEAT MOUNTING KIT AND SEATBELT KITS MAINTENANCE

**14-53. TROOP SEAT MOUNTING KIT AND SEATBELT KITS MAINTENANCE INDEX**

PARA. NO.	TITLE	PAGE NO.
14-54.	Troop Seat Center Mounted Kit Replacement	14-92
14-55.	Fixed Seatbelt Kit Replacement	14-94
14-56.	Floating Seatbelt Kit Replacement	14-96

**14-54. TROOP SEAT CENTER MOUNTED KIT REPLACEMENT**

This task covers:

**a. Removal**

**b. Installation**

**INITIAL SETUP:**

APPLICABLE MODELS

M35A2, M35A2C

MATERIALS/PARTS

Twenty locknuts  
Five cotter pins

PERSONNEL REQUIRED

Two

REFERENCES (TM)

TM 9-2320-361-10  
TM 9-2320-361-20P

EQUIPMENT CONDITION

Parking brake set (TM 9-2320-361-10).

**a. Removal**

1. Remove five cotter pins (5) and pins (3) from hinges of troop seat (1) and side rack (2). Discard cotter pins (5).
2. Rotate two latches (4) and remove troop seat (1) from side rack (2).
3. Remove side rack (2) from pockets (6), (7), (8), (11), and (21).

**NOTE**

Assistant will help with steps 4 through 6.

4. Remove eight locknuts (19), washers (20), screws (23), washers (22), and pockets (6) and (21) from cargo body floor (15). Discard locknuts (19).
5. Remove four locknuts (17), washers (18), two reinforcements (16), four screws (24), washers (25), and pocket (11) from cargo body floor (15). Discard locknuts (17).
6. Remove eight locknuts (14), washers (13), two reinforcements (12), eight screws (9), washers (10), and pockets (7) and (8) from cargo body floor (15). Discard locknuts (14).

## 14-54. TROOP SEAT CENTER MOUNTED KIT REPLACEMENT (Contd)

### b. Installation

#### NOTE

Assistant will help with steps 1 through 5.

1. Position pockets (7) and (8) on cargo body floor (15) with eight washers (10) and screws (9).
2. Install two reinforcements (12) on eight screws (9) with eight washers (13) and new locknuts (14).
3. Position pocket (11) on cargo body floor (15) with four washers (25) and screws (24).
4. Place two reinforcements (16) on four screws (24) and install with four washers (18) and new locknuts (17).
5. Position pockets (6) and (21) on cargo body floor (15) with eight washers (22) and screws (23). Install with eight washers (20) and new locknuts (19).
6. Install side rack (2) in pockets (6), (7), (8), (11), and (21).
7. Install troop seat (1) on side rack (2) with five pins (3) and new cotter pins (5).
8. Raise troop seat (1) in stow position and hold in place with two latches (4).

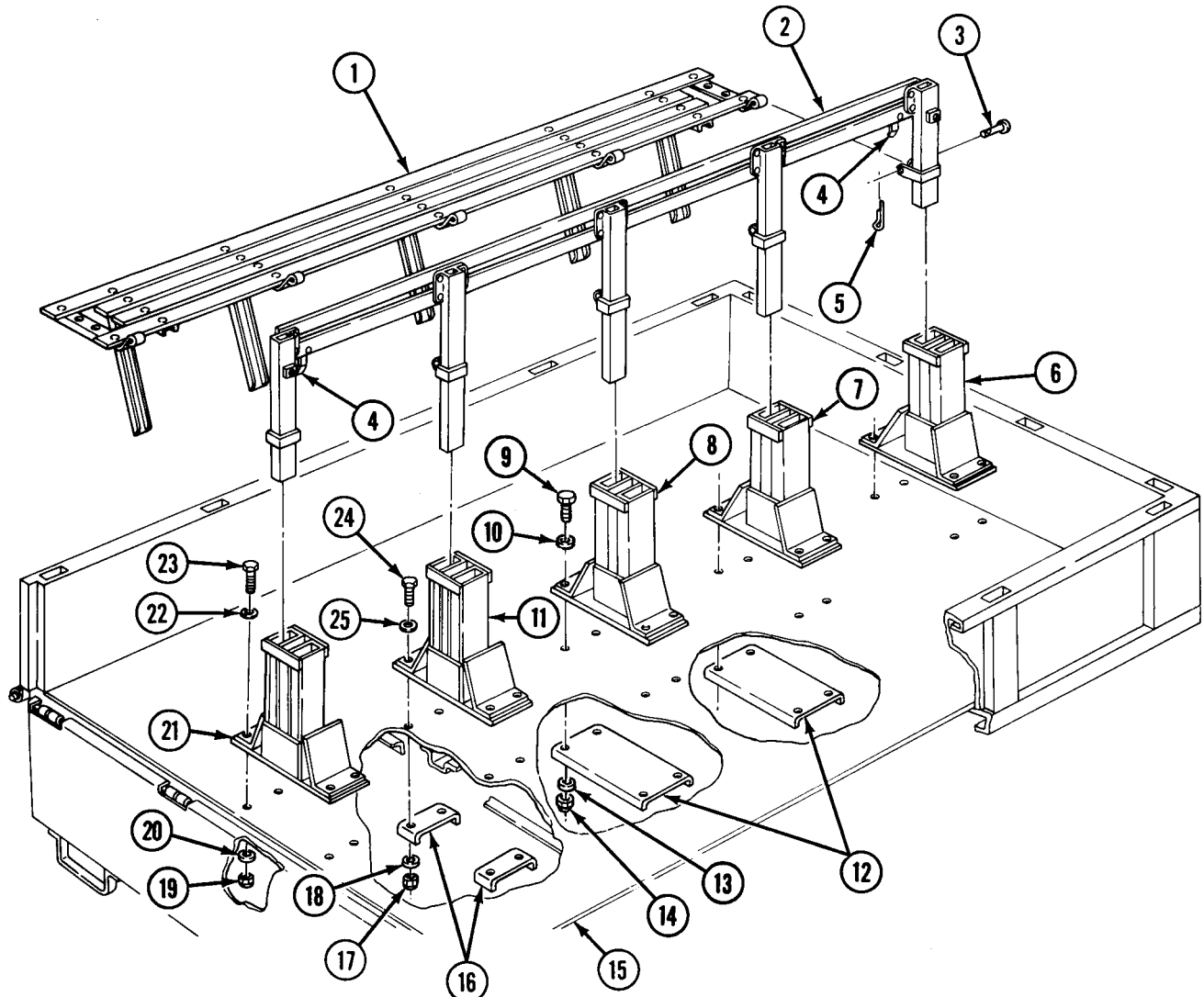

**14-55. FIXED SEATBELT KIT REPLACEMENT**

This task covers:

- a. Removal of Driver's Seatbelts
- b. Installation of Driver's Seatbelts

- c. Removal of Companion Seatbelts
- d. Installation of Companion Seatbelts

**INITIAL SETUP:**

APPLICABLE MODELS

All

TMATERIALS/PARTS

Twelve locknuts

PERSONNEL REQUIRED

Two

REFERENCES (TM)

TM 9-2320-361-10

TM 9-2320-361-20P

EQUIPMENT CONDITION

- Parking brake set (TM 9-2320-361-10).
- Companion seat removed (para. 11-26).

**a. Removal of Driver's Seatbelts**

1. Pull driver's seat (1) to full forward position.
2. Remove locknut (5), screw (2), two washers (3), and seatbelt (4) from back cab panel channel (6). Discard locknut (5).
3. Remove locknut (8), washer (9), screw (25), seatbelt (7), and spacer (26) from back cab panel channel (6). Discard locknut (8).

**NOTE**

Assistant will help with step 4.

4. Remove four locknuts (24), screws (10), and eight washers (11) from back cab panel channel (6). Discard locknuts (24).

**b. Installation of Driver's Seatbelts**

1. Install seatbelt (4) on back cab panel channel (6) with two washers (3), screw (2), and new locknut (5).
2. Install spacer (26) and seatbelt (7) on back cab panel channel (6) with screw (25), washer (9), and new locknut (8).

**NOTE**

Assistant will help with step 3.

3. Install eight washers (11), four screws (10), and new locknuts (24) on back cab panel channel (6).

**c. Removal of Companion Seatbelts**

1. Remove locknut (16), seatbelt (17), spacer (22), screw (12), and washer (13) from back cab panel channel (6). Discard locknut (16).
2. Remove locknut (21), seatbelt (18), screw (19), and washer (20) from back cab panel channel (6). Discard locknut (21).

**NOTE**

Assistant will help with step 3.

3. Remove four locknuts (23), screws (14), and eight washers (15) from back cab panel channel (6).

**14-55. FIXED SEATBELT KIT REPLACEMENT (Contd)**

**d. Installation of Companion Seatbelts**

1. Install seatbelt (18) on back cab panel channel (6) with screw (19), washer (20), and new locknut (21).
  2. Install spacer (22) and seatbelt (17) on back cab panel channel (6) with screw (12), washer (13), and
- NOTE**  
Assistant will help with step 3.
3. Install eight washers (15), four screws (14), and new locknuts (23) on back cab panel channel (6).

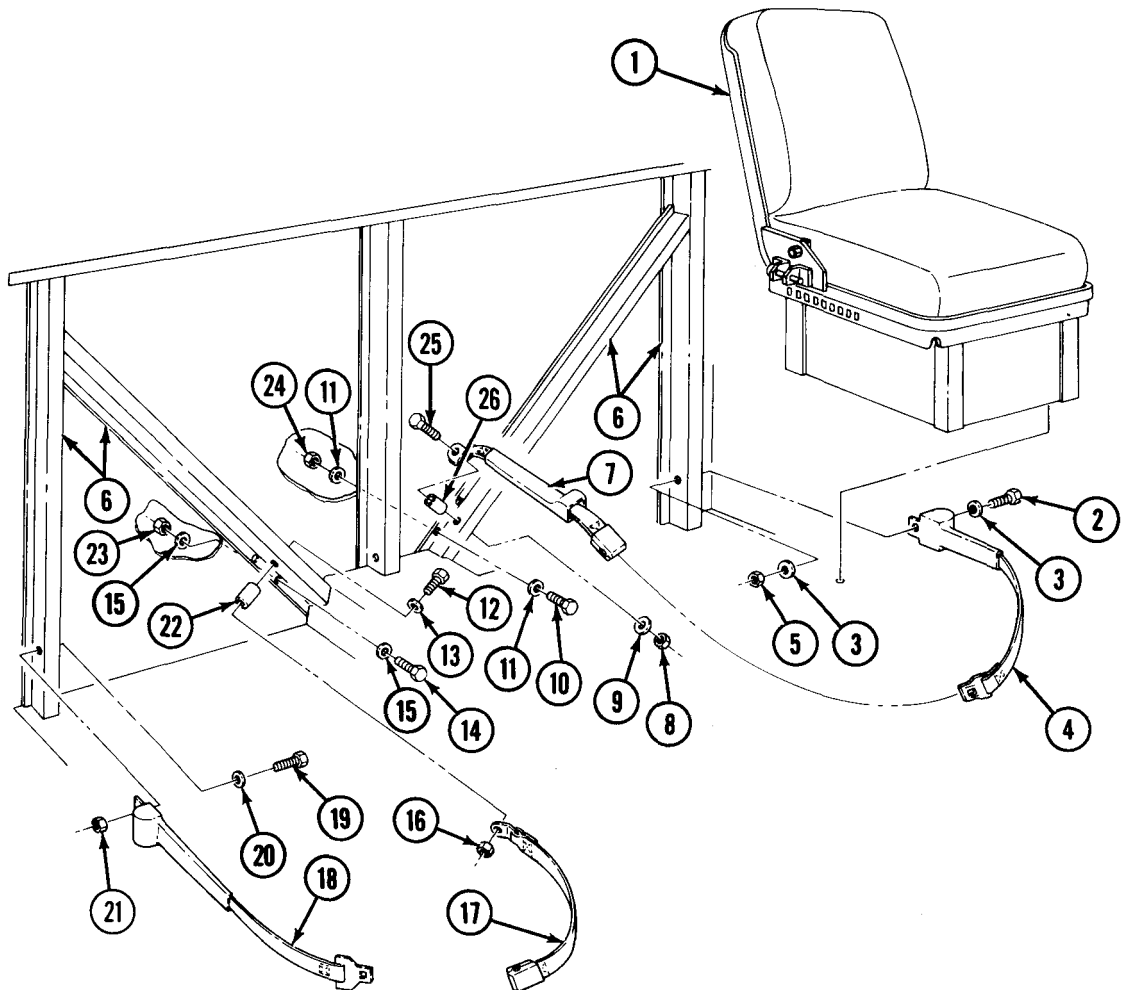

FOLLOW-ON TASK: Install companion seat (para. 11-26).

**14-56. FLOATING SEATBELT KIT REPLACEMENT**

This task covers:

- a. Removal of Driver's Seatbelts
- b. Installation of Driver's Seatbelts

- c. Removal of Companion Seatbelts
- d. Installation of Companion Seatbelts

**INITIAL SETUP:**

APPLICABLE MODELS

All

TMATERIALS/PARTS

Twelve locknuts

PERSONNEL REQUIRED

Two

REFERENCES (TM)

TM 9-2320-361-10

TM 9-2320-361-20P

EQUIPMENT CONDITION

- Parking brake set (TM 9-2320-361-10).
- Companion seat removed (para. 11-26).

**a. Removal of Driver's Seatbelts**

1. Pull driver's seat (1) to full forward position.
2. Remove two screws (2), three washers (3), seatbelts (8), and wire ropes (6) and (7) from driver's seat (1).
3. Remove locknut (11), screw (4), two washers (5), and wire rope (6) from back cab panel channel (26). Discard locknut (11).
4. Remove locknut (28), screw (9), two washers (10), spacer (29), and wire rope (7) from back cab panel channel (26). Discard locknut (28).

**NOTE**

Assistant will help with step 5.

5. Remove four locknuts (27), screws (12), and eight washers (13) from back cab panel channel (26). Discard locknuts (27).

**b. Installation of Driver's Seatbelts**

**NOTE**

Assistant will help with step 1.

1. Install eight washers (13), four screws (12), and new locknuts (27) on back cab panel channel (26).
2. Install wire rope (6) on back cab panel channel (26) with two washers (5), screw (4), and new locknut (11).
3. Install wire rope (7) and spacer (29) on back cab panel channel (26) with two washers (10), screw (9), and new locknut (28).
4. Install two seatbelts (8) and wire ropes (6) and (7) on driver's seat (1) with three washers (3) and screws (2).

**c. Removal of Companion Seatbelts**

1. Remove locknut (18), screw (14), washer (15), seatbelt (19), and spacer (24) from back cab panel channel (26). Discard locknut (18).
2. Remove locknut (23), screw (21), washer (22), and seatbelt (20) from back cab panel channel (26). Discard locknut (23).

**NOTE**

Assistant will help with step 3.

3. Remove four locknuts (25), screws (16), and eight washers (17) from back cab panel channel (26). Discard locknuts (25).

## 14-56. FLOATING SEATBELT KIT REPLACEMENT (Contd)

### d. Installation of Companion Seatbelts

#### NOTE

Assistant will help with step 1.

1. Install eight washers (17), four screws (16), and new locknuts (25) on back cab panel channel (26).
2. Install seatbelt (20) on back cab panel channel (26) with screw (21), washer (22), and new locknut (23).
3. Install spacer (24) and seatbelt (19) on back cab panel channel (26) with screw (14), washer (15), and new locknut (18).

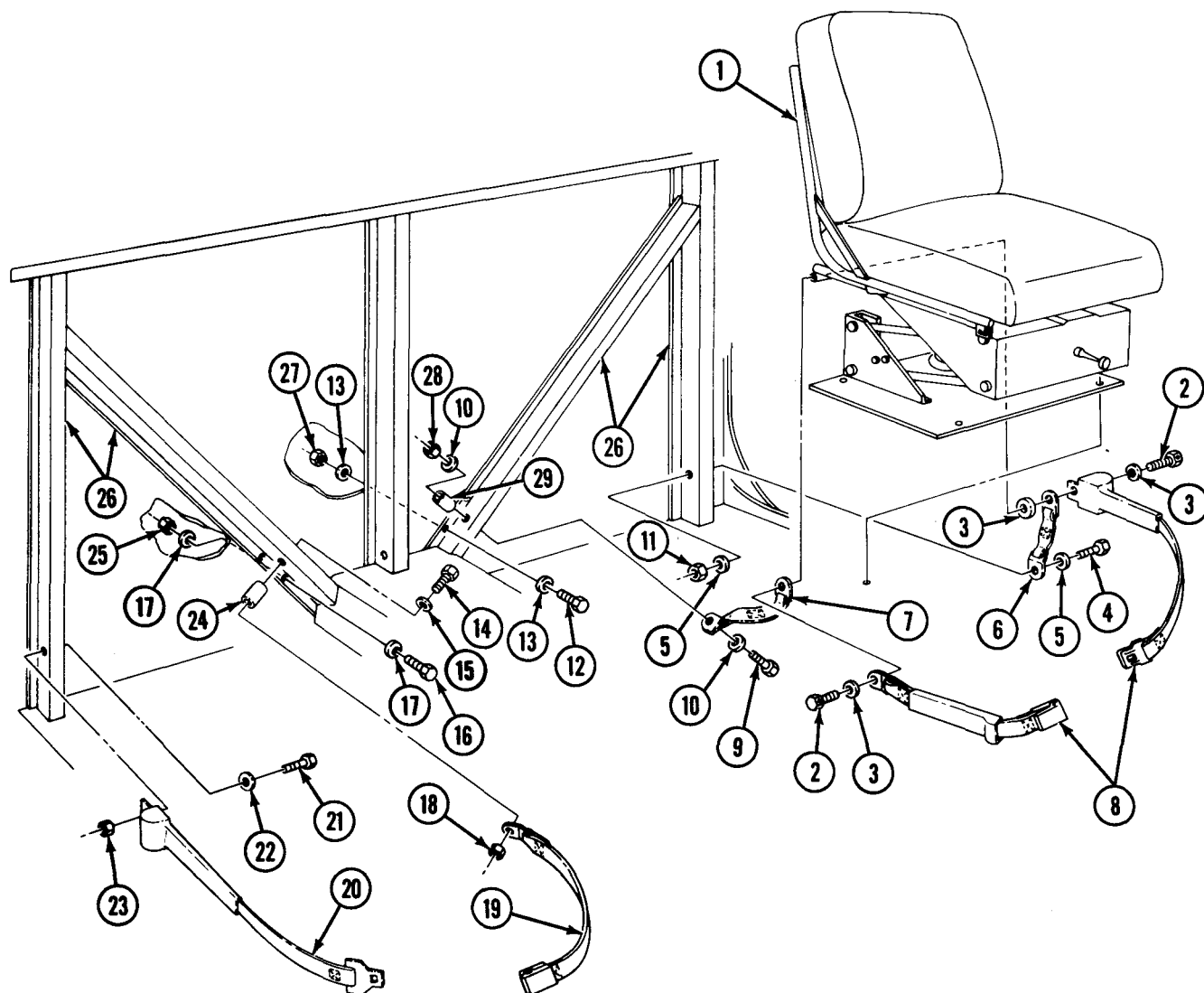

FOLLOW-ON TASK: Install companion seat (para. 11-26).



## CHAPTER 15

### SHIPMENT AND LIMITED STORAGE

Section I. General Preparation of Truck for Shipment (page 15-1)  
Section II. Loading and Movement (page 15-2)  
Section III. Limited Storage (page 15-2)

#### Section I. GENERAL PREPARATION OF TRUCK FOR SHIPMENT

##### 15-1. SCOPE

- a. This section provides instructions on preserving and protecting M44A2 series trucks in preparation for shipment.
- b. Protection for trucks and accompanying equipment must be sufficient to protect the material against deterioration and physical damage.

##### 15-2. CLEANING

###### WARNING

Drycleaning solvent is flammable and will not be used near open flame. Use only in well-ventilated places. Failure to do so may result in injury to personnel.

###### CAUTION

Cleaning materials or paints containing chlorinated hydrocarbon class solvents are not to be used on composite taillights and parking lights. Damage to taillight and parking light lenses may result.

Prior to application of preservatives, surfaces must be cleaned to ensure removal of corrosion, soil, grease, or other acid and alkali residues.

**a. Interior of Truck.** Remove all dirt and other foreign matter from all painted metal surfaces of the truck by scrubbing with cloths soaked in drycleaning solvent (Appendix C, item 26). DO NOT apply solvent to electrical equipment or rubber parts of any nature; use trichloroethylene (Appendix C, item 30) to clean electrical parts and electrical contact points. Use warm water for cleaning rubber parts. Apply preservative compounds to rubber parts as required (TM 9-247).

**b. Exterior of Truck.** Clean exterior surfaces of truck to ensure removal of all dirt and foreign matter. After cleaning, immediately dry parts to remove excess cleaning solutions or residual moisture. Allow parts to air dry or wipe with clean, dry, lint-free cloths (Appendix C, item 21).

##### 15-3. LUBRICATION

###### WARNING

Drycleaning solvent is flammable and will not be used near open flame. Use only in well-ventilated places. Failure to do so may result in injury to personnel.

After cleaning has been accomplished, wipe all grease fittings clean with drycleaning solvent (Appendix C, item 26) and lubricate the truck in accordance with LO 9-2320-209-12-1. Remove excess grease after lubrication and before processing.



#### 15-4. PRESERVATION

All critical unpainted metal surfaces must be protected during shipment. Use procedures and materials listed in a. and b. below. If the preservatives listed below are not available, oil or grease covered in LO 9-2320-209-12-1 maybe used for this purpose, but are effective for only a few days; therefore, equipment protected must be closely watched for signs of corrosion. When selecting preservatives use only those that will not damage the surface to which they are applied.

**a. Battery Leads.** Disconnect both batteries (para. 4-48). Each battery lead terminal, including the jumper lead ends, must be wrapped with tape (Appendix C, item 28).

**b. Miscellaneous Preservation.** Coat all unpainted, exposed, or machined metal surfaces on the exterior of the truck with corrosion-preventive compound (Appendix C, item 11).

#### 15-5. PACKAGING

**Electrical Openings.** Cover all electrical receptacles with tape (Appendix C, item 28) or with plastic caps which will afford the same degree of protection.

#### 15-6. PACKING

Pack all Basic Issue Items (BII) and Additional Authorization List (AAL) items to prevent mechanical damage.

#### 15-7. SHIPMENT OF ARMY DOCUMENTS

Prepare all army shipping documents accompanying truck in accordance with DA Pam 738-750.

### Section II. LOADING AND MOVEMENT

#### 15-8. LOADING AND MOVEMENT

For transportability guidance handling and movement of the M44A2 series trucks, refer to TM 55-2320-209-15-1.

### Section III. LIMITED STORAGE

#### 15-9. SCOPE

Commanders are responsible for ensuring that all trucks issued or assigned to their command are maintained in a serviceable condition and properly cared for, and that personnel under their command comply with technical instructions. Lack of time, lack of trained personnel, or lack of proper tools may result in a unit being incapable of performing maintenance for which it is responsible. In such cases, unit commanders may, with the approval of major commanders, place a truck that is beyond the maintenance capability of the unit in administrative storage. For detailed information, refer to AR 750-1.

## 15-10. LIMITED STORAGE INSTRUCTIONS

**a. Time Limitations.** Administrative storage is restricted to a period of 90 days and must not be extended unless the truck is reprocessed in accordance with b. below.

**b. Storage Procedure.** Perform disassembly only as required to clean and preserve exposed surfaces. Except as otherwise noted, and to the maximum extent consistent with safe storage, place the truck in administrative storage in as nearly a completely assembled condition as practicable. Install and adjust equipment so that the truck may be placed in service and operated with minimum delay.

(1) The truck should be stored on level ground in the most favorable location available, preferably one which affords protection from exposure to the elements and from pilferage.

(2) Perform semiannual Preventive Maintenance Checks and Services (PMCS) on trucks intended for administrative storage. This maintenance consists of inspecting, cleaning, servicing, preserving, lubricating, adjusting, and replacing minor repair parts as required.

(3) Remove both batteries and place in covered storage, maintaining a charged condition.

(4) Provide access to the truck to permit inspection, servicing, and subsequent removal from storage.

## 15-11. INSPECTION IN LIMITED STORAGE

**a.** Conduct visual inspection of vehicles in limited storage at least once a month and immediately following hard rains, heavy snowstorms, windstorms, or other severe weather conditions. Perform disassembly as required to fully ascertain the extent of any discovered deterioration or damage. Maintain a record of these inspections for each vehicle. Attach record to vehicle so it is protected from the weather.

**b.** Perform necessary reprocessing for limited storage when rust or deterioration is found on any unpainted area. Immediately repair damage caused to vehicle by severe weather conditions. Repair damage to On-Equipment Material (OEM) as necessary. Thoroughly clean, dry, and repaint painted surfaces showing evidence of wear.

## 15-12. REMOVAL FROM LIMITED STORAGE

Material removed from administrative storage will be:

- a. Restored to normal operating conditions.
- b. Repaired as required.
- c. Returned to normal PMCS schedule using last type service completed as a starting point.
- d. Calibrate equipment as required (TM 43-180).



## APPENDIX A REFERENCES

### A-1. SCOPE

This appendix lists all forms, field manuals, and technical manuals for use with this vehicle.

### A-2. PUBLICATIONS INDEX

The following index should be consulted frequently for latest changes or revisions and for new publications relating to materiel covered in this manual.

Consolidated Index of Army  
Publications and Blank Forms..... DA Pam 25-30

### A-3. FORMS

Accident Identification Card ..... DD Form 518  
 Equipment Control Record ..... DA Form 2408-9  
 Equipment Component Register ..... DA Form 2408-10  
 Equipment Inspection and Maintenance Worksheet ..... DA Form 2404  
 Equipment Log Assembly (Record) ..... DA Form 2408  
 Equipment Maintenance Log (Consolidated) ..... DA Form 2409  
 Equipment Operators Qualifications Record (Except Aircraft) ..... DA Form 348  
 Exchange Tag ..... DA Form 2402  
 Index of Army Equipment Modification Work Orders ..... DA Pam 310-10  
 Material Condition Status Report ..... DA Form 2406  
 Maintenance Request ..... DA Form 2407  
 Maintenance Request-Continuation Sheet ..... DA Form 2407-1  
 Maintenance Request Register ..... DA Form 2405  
 Operator Report on Motor Vehicle Accidents ..... SF Form 91  
 Organizational Control Record for Equipment ..... DA Form 2401  
 Preventive Maintenance Schedule and Record ..... DD Form 314  
 Processing and Reprocessing Record for Shipment,  
     Storage and Issue of Vehicles and Spare Engines ..... DD Form 1397  
 Product Quality Deficiency Report ..... SF Form 368  
 Recommended Changes to Publications and Blank Forms ..... DA Form 2028  
 Recommended Changes to Equipment Technical Publications ..... DA Form 2028-2  
 The Army Maintenance Management System (TAMMS) ..... DA Pam 738-750  
 U.S. Government Motor Vehicles Operators Identification Card ..... SF Form 46

### A-4. FIELD MANUALS

Basic Cold Weather Manual ..... FM 31-70  
 First Aid for Soldiers ..... FM 21-11  
 Manual for the Wheeled Vehicle Driver ..... FM 21-305  
 Military Symbols ..... FM 101-5-1  
 NBC Protection ..... FM 3-4  
 NBC Decontamination ..... FM 3-5  
 Operation and Maintenance of Army Material in  
     Extreme Cold Weather (0°-65°F) ..... FM 9-207

**A-5. TECHNICAL MANUALS**

Administrative Storage of Equipment ..... TM 740-90-1

Camouflage Materials ..... TM 5-200

Care, Maintenance, and Repair of Pneumatic Tires and Inner Tubes ..... TM 9-2610-200-24

Cooling Systems: Tactical Vehicles ..... TM 750-254

Decontamination Apparatus, Portable, DS2 ..... TM 3-4230-204-12&P

Deep Water Fording of Ordnance Material ..... TM 9-238

Direct Support and General Support Generator Assembly Maintenance ..... TM 9-2920-255-34

Direct Support and General Support Maintenance Manual for Electrical  
Engine Starter ..... TM 9-2920-243-34

Direct Support and General Support Maintenance Manual for Liquid Cooled  
Eight-Cylinder Diesel Turbo-Charged Engine ..... TM 9-2815-210-34

Direct Support and General Support Maintenance Manual for Model  
3052 Transmissions ..... TM 9-2520-246-34

General Support Maintenance Manual (including Repair Parts and Special  
Tools List for Engine Assembly Turbo-Charger) ..... TM 9-2990-201-40&P

Inspection, Care, and Maintenance of Antifriction Bearing Subscription Form ..... TM 9-214

Lubrication Order ..... LO 9-2320-209-12-1

Marking, Packing, and Shipment of Supplies and Equipment ..... TM 746-10

Materials Used for Cleaning, Preserving, Abrading, and Cementing ..... TM 9-247

Operator's Manual for Brake Drum Lathe ..... TM 9-4910-482-10

Operator's and Organizational Maintenance Manual Including Repair Parts  
and Special Tools List for Simplified Test Equipment for Internal  
Combustion Engines ..... TM 9-4910-571-12&P

Operator's Manual for 2-1/2-Ton, 6x6, M44A2 Series Trucks (Multifuel) ..... TM 9-2320-361-10

Operator's Manual for Welding Theory and Application ..... TM 9-237

Operator's and Organizational Maintenance Manual,  
Alarm, Chemical Agent, Automatic Portable Man Pack ..... TM 3-6665-225-12

Operator's, Organizational, Direct Support, and General Support  
Maintenance Manual for Lead-Acid Storage Batteries ..... TM 9-6140-200-14

Operator's, Organizational, Direct Support, and General Support Maintenance  
Manual, Including Repair Parts and Special Tools List for Various Machine  
Gun Mounts and Combinations Used on Tactical and Armored Vehicles ..... TM 9-1005-245-14

Organizational, Direct Support and General Support Maintenance for Vehicle  
Compartment Heaters ..... TM 9-2540-205-24&P

Organizational Maintenance Repair Parts and Special Tools List for  
Truck, 2-1/2-Ton, 6x6, M44A2 ..... TM 9-2320-361-20P

Painting Instructions for Field Use ..... TM 43-0139

Procedures for Destruction of Tank-Automotive Equipment to Prevent Enemy Use ..... TM 750-244-6

Standard and Criteria for Technical Inspection and Declassification of Tires ..... TM 9-2610-201-14

Storage and Materials Handling ..... TM 743-200-1

Transportability Guidance for 2-1/2-Ton, 6 x 6 Trucks ..... TM 55-2320-209-15-1

Use and Care of Hand Tools and Measuring Tools ..... TM 9-243

**A-6. TECHNICAL BULLETINS**

Calibration and Repair Requirements for the Maintenance of Army Material ..... TB 43-180

Color, Marking, and Camouflage Painting of Military Vehicles,  
Construction Equipment, and Material Handling Equipment ..... TB 43-0209

Mandatory Brake Hose Inspection and Replacement Tactical Vehicle  
Subscription Form ..... TB 9-2300-405-14

Quarterly Equipment Improvement Report and Maintenance Digest:  
Tank and Automotive Equipment ..... TB 43-0001-39

**A-6. TECHNICAL BULLETINS (Contd)**

Rustproofing Procedures ..... TB 43-0213  
 Safety Inspection and Testing of Lifting Devices ..... TB 43-0142  
 Tactical Wheeled Vehicles Repair of Frames Subscription Form ..... TB 9-2300-247-40  
 Use of Antifreeze Solutions and Cleaning Compounds in Engine Cooling Systems ..... TB 750-651  
 Warranty Program for 2-1/2-Ton, 6x6, M44A2 Series Trucks ..... TB 9-2320-209-14

**A-7. OTHER PUBLICATIONS**

Depot Maintenance Work Requirement for Front and Rear Winch Assemblies ..... DMWR 9-3830-501  
 Depot Maintenance Work Requirement for Rockwell International  
     Front Axle Assemblies ..... DMWR 9-2520-508  
 Inspection Process, Magnetic Particle ..... MIL-I-6863  
 Liquid Penetrant Methods and Inspection ..... MIL-I-6866  
 Official Nomenclature, Names, and Designations ..... MIL-HDBK-63038-2

**A-8. ARMY REGULATIONS**

Accident Reporting and Records ..... AR 385-40  
 Army Material Maintenance Policy and Retail Maintenance Operation ..... AR 750-1  
 Catalog of Abbreviations and Brevity Codes ..... AR 310-50  
 Dictionary of United States Army Terms ..... AR 310-25  
 Identification and Distribution of DA Publications and  
     Issue of Agency and Command Administration Publication ..... AR 310-2

**A-9. TECHNICAL CATALOG**

Metal Body Repair and Related Operations ..... TC 9-510

**A-10. COMMON TABLE OF ALLOWANCES**

Army Medical Department Expendable/Durable Items ..... CTA 8-100  
 Expendable/Durable Items (Except Medical, Class V, Repair Parts, and Heraldic) ..... CTA 50-970



**APPENDIX B**  
**MAINTENANCE ALLOCATION CHART**  
**Section I.**  
**INTRODUCTION**

**B-1. GENERAL**

**a.** This section provides a general explanation of all maintenance and repair functions authorized at various maintenance categories.

**b.** The Maintenance Allocation Chart (MAC) in section II designates overall authority and responsibility for the performance of maintenance functions on the identified end item or component. The application of the maintenance functions to the end item or component will be consistent with the capacities and capabilities of the designated maintenance categories.

**c.** Section III lists the tools and test equipment (both special tools and common tool sets) required for each maintenance function as referenced from section II.

**d.** Section IV contains supplemental instructions and explanatory notes for a particular maintenance function.

**B-2. MAINTENANCE FUNCTIONS.** Maintenance functions will be limited to and defined as follows:

**a. Inspect.** To determine the serviceability of an item by comparing its physical, mechanical, and/or electrical characteristics with established standards through examination (e.g., by sight, sound, or feel).

**b. Test.** To verify serviceability by measuring the mechanical, pneumatic, hydraulic, or electrical characteristics of an item and comparing those characteristics with prescribed standards.

**c. Service.** Operations required periodically to keep an item in proper operating condition, i.e., to clean (includes decontaminate, when required), to preserve, to drain, to paint, or to replenish fuel, lubricants, chemical fluids, or gases.

**d. Adjust.** To maintain or regulate, within prescribed limits, by bringing into proper or exact position, or by setting the operating characteristics to specified parameters.

**e. Aline.** To adjust specified variable elements of an item to bring about optimum or desired performance.

**f. Calibrate.** To determine and cause corrections to be made or to be adjusted on instruments or test, measuring, and diagnostic equipments used in precision measurement. Consists of comparisons of two instruments, one of which is a certified standard of known accuracy, to detect and adjust any discrepancy in the accuracy of the instrument being compared.

**g. Remove/Install.** To remove and install the same item when required to perform service or other maintenance functions. Install may be the act of emplacing, seating, or fixing into position a spare, repair part, or module (component or assembly) in a manner to allow the proper functioning of an equipment or system.

**h. Replace.** To remove an unserviceable item and install a serviceable counterpart in its place. "Replace" is authorized by the MAC and is shown as the 3d position code of the SMR code.

**i. Repair.** The application of maintenance services, including fault location/troubleshooting, removal/installation, and disassembly/assembly procedures and maintenance actions to identify troubles and restore serviceability to an item by correcting specific damage, fault, malfunction, or failure in a part, subassembly, module (component or assembly), end item, or system.

**j. Overhaul.** That maintenance effort (service/action) prescribed to restore an item to a completely serviceable/operational condition as required by maintenance standards in appropriate technical publications (i.e., DMWR). Overhaul is normally the highest degree of maintenance performed by the Army. Overhaul does not normally return an item to like new condition.

**k. Rebuild.** Consists of those services/actions necessary for the restoration of unserviceable equipment to a like new condition in accordance with original manufacturing standards. Rebuild is the highest degree of materiel maintenance applied to Army equipment. The rebuild operation includes the act of returning to zero those age measurement (hours/miles, etc.) considered in classifying Army equipment/components.



**B-3. EXPLANATION OF COLUMNS IN THE MAC, SECTION II**

**a. Column (1) - Group Number.** Column 1 lists functional group code numbers, the purpose of which is to identify maintenance significant components, assemblies, subassemblies, and modules with the next higher assembly. End item group number shall be "00."

**b. Column (2) - Component/Assembly.** Column 2 contains the names of components, assemblies, subassemblies, and modules for which maintenance is authorized.

**c. Column (3) - Maintenance Function.** Column 3 lists the functions to be performed on the item listed in Column 2. (For detailed explanation of these functions, see paragraph B-2.)

**d. Column (4) - Maintenance Category.** Column 4 specifies, by the listing of a work time figure in the appropriate subcolumn(s), the category of maintenance authorized to perform the function listed in Column 3. This figure represents the active time required to perform that maintenance function at the indicated category of maintenance. If the number or complexity of the tasks within the listed maintenance function vary at different maintenance categories, appropriate work time figures will be shown for each category. The work time figure represents the average time required to restore an item (assembly, subassembly, component, module, end item, or system) to a serviceable condition under typical field operating conditions. This time includes preparation time (including any necessary disassembly/assembly time), troubleshooting/fault location time, and quality assurance/quality control time in addition to the time required to perform the specific tasks identified for the maintenance functions authorized in the maintenance allocation chart. The symbol designations for the various maintenance categories are as follows:

C .....	Operator or Crew
O .....	Unit Maintenance
F .....	Direct Support Maintenance
H .....	General Support Maintenance
D .....	Depot Maintenance

**e. Column (5) - Tools and Equipment.** Column 5 specifies, by number code, those common tools, special tools, TMDE, and support equipment required to perform the designated function.

**f. Column (6) - Remarks.** This column shall, when applicable, contain a letter code, in alphabetic order, which shall be keyed to the remarks contained in Section IV.

**B-4. EXPLANATION OF COLUMNS IN TOOL AND TEST EQUIPMENT REQUIREMENTS, SECTION III**

**a. Column (1) - Reference Code.** The tool and test equipment reference code correlates with a code used in the MAC, Section II, column 5.

**b. Column (2) - Maintenance Category.** The lowest category of maintenance authorized to use the tool or test equipment.

**c. Column (3) - Nomenclature.** Name or identification of the tool or test equipment.

**d. Column (4) - National Stock Number.** The National stock number of the tool or test equipment.

**e. Column (5) - Tool Number.** The manufacturer's part number.

**B-5. EXPLANATION OF COLUMNS IN REMARKS, SECTION IV**

**a. Column (1) - Reference Code.** The code recorded in column 6, Section II.

**b. Column (2) - Remarks.** This column lists information pertinent to the maintenance function being performed as indicated in the MAC, Section II.

Section II. MAINTENANCE ALLOCATION CHART

(1) Group Number	(2) Component/Assembly	(3) Maintenance Function	(4) Maintenance Category					(5) Tools and Equipment	(6) Remarks
			Unit		Direct Support	General Support	Depot		
			C	O	F	H	D		
01	ENGINE								
0100	Engine Assembly	Inspect Test Service Replace	0.1	1.5 2.0	7.0			1 1 1,71,73,79, 94,95,102, 110	A A
		Repair				16.0		11,12, 21 thru 25, 30,31,32	U
		Overhaul				40.0		16 thru 20	B
	Pad, Engine Mounting	Inspect Replace		0.2 1.0				1	
	Bracket, Front and Rear Engine Mounting	Inspect Replace		0.2	2.0			1,71,94,95, 97	
0101	Head, Cylinder Assembly	Inspect Replace			0.2 4.0			1,13,15,72 1,13,14, 23 thru 26, 30,42,72	
		Repair				5.0		1,23 thru 26,42,72	U
	Sleeve, Cylinder	Inspect Replace				0.3 2.0		1,2,15,21, 22	U
0102	Crankshaft	Inspect Replace				1.5 3.0		1,10,27, 28,64,65	U
	Damper, Vibration	Inspect Replace		0.2	2.5			1,71,88, 106,107	
0103	Flywheel Assembly	Inspect Replace Repair			1.0 4.0			1,72 1,29,72	U
0104	Pistons, Connecting Rods	Inspect Replace				0.3 2.0		1,11,12, 71,106, 107	U
0105	Guide, Valve	Inspect Replace				0.2 0.5		1,2,24, 25,31, 32	U
	Spring, Valve	Inspect Replace				0.3 0.5		1,2,25	U
0105	Valves, Intake and	Inspect			0.2				

Section II. MAINTENANCE ALLOCATION CHART (Contd)

(1) Group Number	(2) Component/Assembly	(3) Maintenance Function	(4) Maintenance Category					(5) Tools and Equipment	(6) Remarks
			Unit		Direct Support	General Support	Depot		
			C	O	F	H	D		
0105	<b>ENGINE (Contd)</b>								
	Exhaust	Replace			1.5			1,23,26,30,31	U
		Repair			0.5			1,31	U
	Arm, Valve Rocker Intake/Exhaust	Inspect			0.2				
		Adjust			0.5			1,71,106,107	
		Replace			1.5			1,31	
		Repair			0.5			1,31	U
	Rod, Push Intake Exhaust/Injector	Inspect			0.2				
		Replace			0.5			1,71,106,107	
	Shaft Assembly, Rocker Arm	Inspect			0.3				
		Replace			2.0			1,71,106,107	
	Camshaft and Bearing	Inspect				0.5			
		Replace				4.0		1,2,27,33,39,40,41	U
0106	Timing Gear Cover and Seal	Inspect			0.3				
		Replace			4.0			1	
		Repair			1.0			1,2	U
	Pump, Oil	Inspect			0.3			1	U
		Replace			2.0			1,83,113	U
		Repair					4.0	1,83,113	U
	Pan, Oil	Inspect		0.1				1	U
		Replace			1.0			1,86	
	Engine Oil Cooler and Housing	Replace			0.7			1,108,109	
		Repair			3.0			1,34,35,42,43	
	Oil Filter	Inspect		0.1					
		Replace		0.5				1	
	Breather, Crankcase	Inspect		0.5					
	Replace		1.0				1		
0108	Manifold, Intake	Inspect			0.5				
		Replace			4.0			1	
	Manifold, Exhaust	Inspect			0.5				
	Replace			0.5			1		
	Repair			4.0			1,2		
02	<b>CLUTCH</b>								
0200	Plate Pressure	Inspect			0.2				
		Replace			2.0			1,69	
	Disk, Clutch	Inspect			0.3				
	Replace						1,69		

Section II. MAINTENANCE ALLOCATION CHART (Contd)

(1) Group Number	(2) Component/Assembly	(3) Maintenance Function	(4) Maintenance Category					(5) Tools and Equipment	(6) Remarks
			Unit		Direct Support	General Support	Depot		
			C	O	F	H	D		
0202	CLUTCH (Contd) Linkage, Clutch Pedal and Control	Inspect		0.2				1,9,69 1	U
		Adjust		0.5					
		Replace		1.0					
03	FUEL SYSTEM								
0301	Injectors, Fuel	Test				0.5		1,36	U
		Replace			0.5			1,72	U
		Repair				1.0		1,35,37, 72	U
0302	Pump, Fuel Injector	Calibrate				2.0		1,37,38	U
		Inspect			0.5				
		Test				2.0		1,88	U
0303	Pump, Fuel, In-Tank	Adjust				2.0		1	U
		Replace			2.0			1,37	U
		Repair				4.0		1,37,38	U
0304	Element, Air Cleaner	Calibrate			1.0			1,37,38	U
		Inspect		0.2					
		Test		0.5				1,63,68	
0304	Indicator, Air Cleaner	Replace		1.5				1	
		Repair		1.5				1,3,63,68	
		Inspect	0.1						A
0304	Lines and Connections, Vent	Service	0.5						A
		Replace		0.5				1	
		Inspect		0.5					
0304	Hoses and Clamps	Replace		1.0				1	D
		Inspect	0.1						A
		Replace		0.2				1	
0305	Turbocharger	Inspect	0.2						A
		Replace		0.5				1	
		Repair			2.0			1	V
0306	Tank, Fuel	Replace		1.0				1	
		Repair			1.0			1,2	C
		Inspect		0.3				1	
0309	Fuel Filter and Housing	Replace		1.5				1	D
		Inspect	0.1						A
		Replace		1.0				1	D
0312	Control, Accelerator, and Throttle Control Linkage	Inspect		0.2				1	
		Adjust		0.5				1	
		Replace		1.0					
04	EXHAUST SYSTEM								
0401	Exhaust Pipes, Clamps Shields	Inspect	0.5	0.5					
		Replace		2.0				1	

Section II. MAINTENANCE ALLOCATION CHART (Contd)

(1) Group Number	(2) Component/Assembly	(3) Maintenance Function	(4) Maintenance Category					(5) Tools and Equipment	(6) Remarks
			Unit		Direct Support	General Support	Depot		
			C	O	F	H	D		
<b>05</b>	<b>COOLING SYSTEM</b>								
0501	Radiator	Inspect Test Service Replace Repair	0.2		0.5			1 1 1 1,13	A E A E
0504	Hoses, Radiator	Inspect Replace	0.2	0.5			1	A	
	Water Pump	Inspect Replace		0.5 1.0			1		
0505	Fan Blade	Inspect Replace		0.1 0.5			1		
	Belt, Fan Assembly	Inspect Adjust Replace	0.1	0.3 0.5			1 1		
<b>06</b>	<b>ELECTRICAL SYSTEM</b>								
0601	Alternator	Inspect Test Adjust Replace Repair		0.1 0.5 0.6 1.0	2.5		1,68 1 1,88 1,3,4,66, 67,73,78	F	
0603	Starter Motor	Inspect Test Replace Repair		0.1 0.5 3.5	1.0		1,68 1 1,3,4,67, 73,78	G	
0607	Instruments and Gages	Inspect Test  Replace	0.1	0.2 0.2  1.0			1,60,63, 68 1	A	
0608	Control, Directional Turn Indicator	Test  Replace		0.2  0.5			1,68 1		
0609	Lights	Adjust Replace		0.2 0.5			1 1		
0610	Sending Units and Warning Switches	Inspect Replace	0.1	0.3			1,68		
0611	Horn Assembly	Inspect Replace	0.1	0.5			1	A	
	Switch, Horn	Test Replace		0.1 0.5			1,68 1		

Section II. MAINTENANCE ALLOCATION CHART (Contd)

(1) Group Number	(2) Component/Assembly	(3) Maintenance Function	(4) Maintenance Category					(5) Tools and Equipment	(6) Remarks
			Unit		Direct Support	General Support	Depot		
			C	O	F	H	D		
<b>ELECTRICAL SYSTEM (Contd)</b>									
0612	Batteries	Inspect	0.1						A
		Test		0.5				1,68	A
		Service	0.5					1	A
		Replace Repair		0.5		1.0		1,3,4	H
0612	Cables, Battery	Inspect		0.1					A
		Replace		1.0				1	
		Repair		0.5				1	
0612	Box, Battery	Inspect	0.1						A
		Service		1.5				1	A
		Replace		1.5				1	
		Repair			0.5			1,2	C
0613	Chassis Wiring Harness	Test		0.5				1,68	
		Replace			4.5			1,67,68, 73	
		Repair		1.0				1,3,4,67, 68	
<b>07 TRANSMISSION</b>									
0700	Transmission Assembly	Inspect	0.2						A
		Service	0.5	1.0				1	A
		Replace			4.0			1,72,79, 80,86	
		Repair			8.0	10.0		1,44,45, 72,79, 80,86	I
		Overhaul					20.0	I	
<b>08 TRANSFER ASSEMBLY</b>									
0801	Power Transfer Assembly	Inspect		0.3				1	
		Service		0.5				1	A
		Replace			5.0			1,46 thru 51, 72,75,76, 102	
0803	Controls and Linkage, Transfer	Repair			3.0	4.0			J
		Overhaul					9.5		J
		Inspect		0.5				1	A
		Adjust		0.3				1	
0803	Unit, Air Sprag	Replace		1.5				1	
		Test	0.1					1	
		Replace Repair			1.0	2.1		1	

Section II. MAINTENANCE ALLOCATION CHART (Contd)

(1) Group Number	(2) Component/Assembly	(3) Maintenance Function	(4) Maintenance Category					(5) Tools and Equipment	(6) Remarks
			Unit		Direct Support	General Support	Depot		
			C	O	F	H	D		
<b>09</b>	<b>PROPELLER AND PROPELLER SHAFTS</b>								
0900	Propeller Shafts	Inspect Service	0.1	0.5				1	A A
		Replace		1.5				1,114	
		Repair		1.0				1,114	
	Bearing, Center	Inspect		0.2					
		Replace		1.5				1,114	
	Joint, Universal	Inspect		<b>0.2</b>					A
		Service		<b>0.3</b>				1	
		Replace		1.5				1,114	
<b>10</b>	<b>FRONT AXLE</b>								
1000	Front Axle Assembly	Inspect	0.1	0.5					A
		Service		1.0				1	
		Replace			5.0			1,70,76	
		Overhaul					14.0	1	K
1002	Carrier Assembly, Differential	Inspect		<b>0.5</b>				1	A
		Service		<b>0.5</b>				1,102	
		Replace			7.0			1,55 thru	
		Repair				6.0		59,71,72, 81,82,87 thru 90, 112,121	
		Overhaul				8.0		1,71,72, 81,82,87 thru 90, 112,121	
	Seal, Pinion	Inspect			<b>0.2</b>				
		Replace			<b>2.0</b>			1,51,57 62	
	Flange, Companion	Inspect			0.3				
		Replace			2.0			1,88	
		Repair			2.6			1	
1004	Steering Mechanism	Inspect		<b>0.5</b>					A
		Service		<b>0.2</b>				1	
		Adjust		<b>1.0</b>				1	
		Replace		<b>3.0</b>				1	
	Knuckle, Steering	Inspect			0.5			1,71,81, 82,87,88, 92,93	
		Service		0.2				1	A
		Replace			4.0			1,52,71, 92,93	
	Boot, Dust (CV)	Inspect		0.3					A
		Replace		0.7				1	

Section II. MAINTENANCE ALLOCATION CHART (Contd)

(1) Group Number	(2) Component/Assembly	(3) Maintenance Function	(4) Maintenance Category					(5) Tools and Equipment	(6) Remarks
			Unit		Direct Support	General Support	Depot		
			C	O	F	H	D		
11	<b>REAR AXLE</b>								
1100	Rear Axle Assembly	Inspect Service Replace	0.1	0.5 0.5	9.0			1 1,71,86, 94,95,96	A
		Overhaul					14.0		K
1102	Carrier Assembly, Differential	Inspect Service Replace Repair		0.5 0.5	7.0		6.0	1 1,102 1,55 thru 59, 71,72,81, 82,87 thru 90,112,121	A
		Overhaul					8.0	1,71,72, 81,82,87 thru 90, 112,121	
1102	Seal, Pinion	Inspect Replace			0.2 1.0			1,51,57, 62	
	Flange, Companion	Inspect Replace Repair			0.3 2.0 2.6			1 1	
12	<b>BRAKES</b>								
1201	Drum, Handbrake	Inspect Replace Repair		1.0 1.5	2.5			1,86 1,77,81	W
	Linkage, Handbrake	Inspect Adjust Replace	0.1 0.2	0.5 1.0				1 1	
	Shoes, Handbrake	Inspect Adjust Replace Repair		1.0 1.0 2.5	4.5			1 1,86 1,77,85,91	
1202	Shoes, Service Brakes	Inspect Adjust Replace Repair		0.5 1.0 3.0	0.5			1 1,86 1,77,85,91	
1204	Master Cylinder	Inspect Test Replace	0.2	1.0 2.0				1,60 1	
	Cylinder, Wheel	Inspect Replace		0.1 2.0				1	
	Cylinder, Air-Hydraulic	Inspect Replace		0.1 1.0				1	
	Lines and Fittings	Inspect Replace		0.1 3.5				1	D,Q



Section II. MAINTENANCE ALLOCATION CHART (Contd)

(1) Group Number	(2) Component/Assembly	(3) Maintenance Function	(4) Maintenance Category					(5) Tools and Equipment	(6) Remarks
			Unit		Direct Support	General Support	Depot		
			C	O	F	H	D		
1206	BRAKES (Contd) Brake Pedal	Inspect	0.2						A
		Adjust		0.5				1	
		Replace		0.2				1	
1208	Air Reservoirs	Inspect		0.2					
		Service Replace	0.2	0.8				1	
1209	Governor, Air	Adjust		0.3				1	
		Replace		0.5				1	
1209	Compressor, Air	Inspect	0.1						
		Adjust		0.5				1	
		Replace		1.5				1,8	
1209	Belt, Drive	Inspect	0.1						A
		Adjust		0.3				1	
		Replace		0.5				1	
<b>13</b>	<b>WHEELS, HUBS, AND DRUMS</b>								
1311	Bearings, Wheel	Inspect		0.3					
		Service		1.0				1,86	
		Adjust Replace		0.5 2.5				1,86 1,86	
1311	Drums, Service Brake	Inspect		0.1	0.2			1,81	W
		Replace		1.5				1,61,86	
		Repair			2.5			1,61,81	
1311	Hubs, Wheel	Inspect		0.1					
		Replace		1.5				1,86	
		Wheel/Tire Assembly	Inspect	0.1					
1311	Tires	Service	0.2						A,L
		Replace	2.0						A,L
		Inspect	0.2						A,L
1313	Tires	Service	0.2						A
		Replace		1.0				1,86	
		Repair Rebuild		1.0			2.0	1	L L
1313	Tubes	Inspect		0.2					
		Replace		0.5				1	
		Repair		3.0				1	
<b>14</b>	<b>STEERING</b>								
1401	Steering Gear	Inspect	0.2						
		Adjust		0.5				1	
		Replace Repair			3.0	5.5		1,72 1,52,54, 72,73,81 thru 84	
1401	Link, Front Drag	Inspect		0.2					
		Replace		1.0				1	

Section II. MAINTENANCE ALLOCATION CHART (Contd)

(1) Group Number	(2) Component/Assembly	(3) Maintenance Function	(4) Maintenance Category					(5) Tools and Equipment	(6) Remarks	
			Unit		Direct Support	General Support	Depot			
			C	O	F	H	D			
1401	STEERING (Contd) Rod, Tie Assembly	Inspect		0.2						
		Adjust		0.5				1		
		Replace		1.5				1		
	Arm, Pitman Steering	Inspect		0.1						
		Replace		1.0					1,119	
		Wheel, Steering	Inspect		0.2					
15	FRAME AND TOWING ATTACHMENTS Frame Assembly	Inspect		0.5	2.0					
		Repair			4.0	9.5			1,70,86,90,111	
		Hook, Pintle	Inspect	0.1						
	Spare Tire Carrier	Service		0.1						
		Replace		0.5					1	
		Repair		2.0					1	
1506	Fifth Wheel	Inspect	0.2							
		Service		0.5						
		Replace		2.5					1	
16	SPRINGS AND SHOCK ABSORBERS Front Spring	Inspect		0.5						
		Replace		3.0					1,86	
		Repair		5.5					1,85,118	
	Shackles and Bolts	Inspect		0.1						
		Replace		1.0					1,86	
	Springs, Rear and Seat	Inspect		0.3						
Replace			4.0					1,86		
Repair			6.3					1,86		
1604	Shock Absorber	Inspect		0.1						
		Replace		1.5				1		
1605	Torque Rods	Inspect		0.1						
		Replace		1.5				1,86		
18	BODY, CAB, AND HOOD Doors	Inspect	0.1							
		Service	0.1	0.1						
		Adjust		0.5					1	
		Replace		1.0					1	
		Repair				2.6			1,2,5,6	

Section II. MAINTENANCE ALLOCATION CHART (Contd)

(1) Group Number	(2) Component/Assembly	(3) Maintenance Function	(4) Maintenance Category					(5) Tools and Equipment	(6) Remarks
			Unit		Direct Support	General Support	Depot		
			C	O	F	H	D		
1801	BODY, CAB, AND HOOD (Contd) Cab	Inspect	0.2						
		Replace				6.0		1	A
		Repair			6.0			1,2,5,6	P
1802	Hood	Inspect	0.1					1	
		Adjust		0.5				1	
		Replace Repair		1.0	2.0			1,2,6	N
1806	Fenders	Inspect	0.1						
		Replace		2.0					
		Repair			3.0			1,2,6	N
1806	Frame Assembly, Wind- shield With Glass	Replace		2.0				1	
		Repair			3.5			1,5	
		Inspect	0.1					1	
1806	Seats	Replace		0.5				1	
		Repair		1.5				1	T
		Inspect	0.2						
1810	Body, Cargo	Replace			3.0			1,71,94 thru 96, 116	
		Inspect	0.2					1,2,6	C,N
		Repair			10.0				
1810	Tailgate	Inspect	0.2					1	
		Replace		1.0				1,2,6	C,N
		Repair			2.0				
1810	Racks	Inspect	0.2					1	
		Replace		1.0				1	
		Repair		2.0					
1810	Seat, Troop	Inspect	0.2					1	
		Replace		1.0				1	
		Repair		2.0					
1810	Body, Dump	Inspect	0.2						
		Replace			6.0			1,75,76	
		Repair				3.0		1,2,6	C,N
1810	Tailgate	Inspect	0.2					1	A
		Replace		0.5				1,2,6	C,N
		Repair			2.8				
1811	Body, Water Tank	Inspect	0.3						A
		Replace			4.0			1,71,72, 94 thru 97	
		Repair				10.0		1,2,6	C,N
1811	Covers, Manhole	Inspect	0.1					1	A
		Replace		0.3				1	
		Repair		1.7					
1811	Pump, Delivery	Inspect	0.2					1	A
		Replace		0.5				1,100	
		Repair			1.5				

Section II. MAINTENANCE ALLOCATION CHART (Contd)

(1) Group Number	(2) Component/Assembly	(3) Maintenance Function	(4) Maintenance Category					(5) Tools and Equipment	(6) Remarks
			Unit		Direct Support	General Support	Depot		
			C	O	F	H	D		
1811	<b>BODY, CAB, AND HOOD (Contd)</b>								
	Control Levers, Cables, and Linkage	Inspect Replace Repair	0.3	0.5 1.8				1 1	A
	Valves, Gate/Discharge	Replace Repair		0.5	1.0			1 1,73,74, 82,98,99, 117	
	Shaft, Propeller	Service Replace Repair		0.1 0.8 1.4				1,114 1,114	
	Door, Rear Compartment	Replace Repair		0.5	1.5			1 1,72,73, 94 thru 97	N
	Body, Fuel Tank	Inspect Replace	0.3		4.0			1,72,73, 94 thru 97	
		Repair				10.0		1,2,6	C,N
	Pump, Delivery	Inspect Replace Repair	0.3	0.5	1.5			1 1,100	A
	Control, Levers, Cables and Linkage	Inspect Replace Repair	0.3	0.5 1.8				1 1	A
	Valves, Gate/Discharge	Replace Repair		0.5	1.0			1 1,73,74, 82,98,99, 117	
	Shaft, Propeller	Service Replace Repair		0.1 0.8 1.4				1,114 1,114	
	Covers, Manhole	Inspect Replace Repair	0.1	0.2 0.7				1 1	A
	Sump Assembly	Inspect Replace Repair	0.3		0.5 1.5			1 1	
	Door, Rear, Compartment	Replace Repair		0.5	1.5			1 1,72,73 94 thru 97	N
1812	Body, Shop Van	Inspect	0.2						
		Replace Repair			3.5	12.0		1,75,84 1,2,6	A N

Section II. MAINTENANCE ALLOCATION CHART (Contd)

(1) Group Number	(2) Component/Assembly	(3) Maintenance Function	(4) Maintenance Category					(5) Tools and Equipment	(6) Remarks
			Unit		Direct Support	General Support	Depot		
			C	O	F	H	D		
1812	<b>BODY, CAB, AND HOOD (Contd)</b>								
	Door, Rear Van	Inspect Replace	0.2	2.5				1	A
	Window, Front/Side	Replace Repair			0.6 2.0			1 1,5	
	Harness Main Wiring	Replace Repair		1.0	5.0			1,67,68 1,67,68	
	Body, Earthboring	Inspect Replace	0.2		3.0			1,72,75, 76	A
	Boring Case and Gears	Repair				10.0		1,2,6	C,N
		Service Replace		0.1		2.0		1,81,82, 87,88	
	Clutch and Brake Assembly	Repair				6.0		1,81,82, 87,88	
		Service Replace Repair		0.1	2.0		4.0	1,2,3 1,2,3	
	Clutch and Brake Feed	Replace Repair				4.0 8.0		1,88 1,88	
	Leveling Worm Assembly, Horizontal	Inspect Service	0.1 0.1						
		Replace Repair				1.4 3.0		1 1,74,82, 83	A
	Leveling Worm Assembly, Vertical	Inspect Service	0.1 0.1						
		Replace Repair				1.5 3.0		1 1,74,84	A
	Drive Chain, Horizontal. Vertical	Inspect Adjust	0.1						
		Replace		0.4 0.5				1 1	A
	Level Worm Drive Cover and Chain	Inspect Adjust	0.1						
		Replace		0.4 0.5				1 1	A
	Power Leveler Assembly	Service Replace Repair	0.1				1.0 3.0	1,84 1,74,84	A
		Inspect Service Adjust Replace	0.1 0.1		4.0	1.4		1,87,96, 101	A
Intermediate Case and Gears	Repair				3.0		1,81,82, 87,96,101		

Section II. MAINTENANCE ALLOCATION CHART (Contd)

(1) Group Number	(2) Component/Assembly	(3) Maintenance Function	(4) Maintenance Category					(5) Tools and Equipment	(6) Remarks
			Unit		Direct Support	General Support	Depot		
			C	O	F	H	D		
1812	<b>BODY, CAB, AND HOOD (Contd)</b>								
	Clutch Lever Assembly	Service Replace Repair		0.1 2.0 0.7				1 1	
	Gear and Housing, Main Drive Idler	Inspect	0.2						A
		Service	0.1						
		Replace Repair				2.0 3.0		1,23 1,23	
	Shaft, Propeller Drive	Inspect	0.2						A
		Service	0.1						
		Replace Repair		0.4 0.8				1 1,114	
	Outriggers and Jacks	Inspect	0.8						A
		Replace		0.4				1	
		Repair			1.0			1,2,6	
	Reservoir, Hydraulic	Service	0.1						A
		Replace			0.5			1	
	Shaft Assembly, Pump	Service	0.1						A
		Replace		0.4				1	
		Repair		0.5				1,114	
	Derrick Assembly	Service		0.1					
		Replace			1.0			1	
		Repair			2.0			1,82	
	Cab Protector	Inspect	0.1						A
Replace			0.8				1		
Repair				1.0			1	C,N	
Body, Pipeline Truck	Inspect	0.1						A	
	Replace			3.0			1,72,75, 76		
	Repair			4.0			1,2,6	C,N	
Cab Protector	Inspect	0.2						A	
	Replace		0.8				1		
	Repair			1.0			1	C,N	
Toolbox	Inspect	0.1							
	Replace			0.5			1,72,75, 76		
	Repair			1.0			1,2,6		
Roller, Rear	Service	0.1						A	
	Replace			2.0			1		
	Repair			2.5			1,87,88		
Roller, Auxiliary	Inspect		0.1					A	
	Replace		0.5				1		
20	<b>HOIST, WINCH POWER</b>								

Section II. MAINTENANCE ALLOCATION CHART (Contd)

(1) Group Number	(2) Component/Assembly	(3) Maintenance Function	(4) Maintenance Category					(5) Tools and Equipment	(6) Remarks	
			Unit		Direct Support	General Support	Depot			
			C	O	F	H	D			
2001	CONTROL UNIT, AND POWER TAKEOFF Winch, Front and Rear	Inspect	0.1							
		Test		0.7				1		
		Service		0.5						
		Adjust		0.5				1		
		Replace		3.0				1		
		Repair			4.8			1,71,81,82,87,94 thru 96,116		
		Overhaul						11.0		
		Band, Automatic	Adjust		0.5				1	
			Replace			2.0				
		Cable, Winch	Inspect	0.5						A,R
			Service	0.5						
			Replace		1.0				1	
			Repair		0.5				1	R
			Shaft Assembly, Drive	Inspect		0.3				
		Replace		1.0			1			
		Repair		2.0			1			
	Drivechain, Rear Winch	Adjust		0.5						
		Replace		1.0				1		
	Brakedrum (front only)	Adjust		1.0				1		
		Replace			2.0					
	Lines and Fittings, Hydraulic	Inspect		0.2						
		Replace			0.5				D	
	Valve, Control	Replace		1.0				1		
		Repair			2.7					
2004	Power Takeoff, Transmission	Inspect		0.2						
		Adjust		0.2				1		
		Replace			1.0			1,71		
		Repair			3.0			1,71,87		
		Overhaul						3.0		
		Controls and Linkage, Power Takeoff	Adjust		0.3				1	
			Replace			1.0				
		Power Divider	Replace			1.2			1,75,102, thru 104	
			Repair				2.5		1,81,82,87,88	
			Power Divider Controls and Linkage	Adjust		0.3				1
		Replace		0.5				1		
	Shaft, Propeller Drive	Service		0.1					A	
		Replace		0.8				1,114		
		Repair		1.4				1,114		

Section II. MAINTENANCE ALLOCATION CHART (Contd)

(1) Group Number	(2) Component/Assembly	(3) Maintenance Function	(4) Maintenance Category					(5) Tools and Equipment	(6) Remarks
			Unit		Direct Support	General Support	Depot		
			C	O	F	H	D		
<b>22</b>	<b>BODY, CHASSIS, AND ACCESSORY ITEMS</b>								
2201	Bows	Inspect Replace	0.1	1.0			1	A	
	Cover, Cap Top	Inspect Replace Repair	0.1	0.5	1.5		1 1	A T	
	Curtains, Body Cover	Inspect Replace Repair	0.1	1.0	1.0		1 1	A T	
2202	Motor, Windshield	Inspect Replace	0.1	0.7			1	A	
	Arm and Blade, Windshield	Inspect Adjust Replace	0.1	0.1 0.2			1 1	A	
	Washer Bottle and Control	Service Replace	0.1	1.0			1	A	
	Mirror, Rearview	Inspect Replace	0.5	0.5			1	A	
	Spotlight	Replace Repair		0.5 0.5			1 1		
2207	Heater, Personnel	Inspect Replace	0.2	3.0			1	A	
<b>33</b>	<b>SPECIAL PURPOSE KITS</b>								
3303	Winterization Kits								
	Kit, Fuel Burning Personnel Heater	Inspect Install	0.2		6.0		1,3,4	A P	
	Heater, Fuel Burning Personnel	Inspect Replace Repair	0.1	0.4	2.0		1 1	A	
	Kit, Engine Coolant Heater	Inspect Install	0.2		10.0		1,3,4	A P	
	Heater, Engine Coolant	Inspect Replace Repair	0.1	0.4	2.0		1	A	
	Kit, Gearshift and Transfer Case Cover	Install			0.5		1	P	
	Kit, Radiator Cover	Inspect Install	0.1		1.2		1	A P	
	Kit, Cargo Body Personnel Heater	Install Repair			6.0 2.0		1 1	P S	



Section II. MAINTENANCE ALLOCATION CHART (Cont'd)

(1) Group Number	(2) Component/Assembly	(3) Maintenance Function	(4) Maintenance Category					(5) Tools and Equipment	(6) Remarks
			Unit		Direct Support	General Support	Depot		
			C	O	F	H	D		
3303	SPECIAL PURPOSE KITS (Contd) Kit, Van Body Primary and Secondary Heater	Install			6.0			1,3,4	P
		Repair			2.0			1,3,4	S
3305	Deepwater Forging Kits	Inspect	0.3						A
		Install			12.0			1	P
3307	Special Purpose Kits								
	A-Frame Kit	Inspect	0.2						A
		Install		1.5				1	P
	Kit, Fixed Seatbelt	Install			4.0			1,120	P
	Kit, Floating Seatbelt	Install			4.0			1,120	P
	Kit, Alcohol Evaporator	Install			0.7			1	P
	Hardtop Kit	Inspect	0.1						A
		Install			4.0			1	P
	Slave Receptacle Kit	Install			2.0			1,120	P
	100 Amp Alternator Kit	Install			8.0			1,3,4,120	P
	Machine Gun Mounting Kit	Install		5.0				1	P
	Rifle Mounting Kit	Inspect		0.2					A
		Install			2.0			1,120	P
	Decontamination Mounting Kit	Install		1.0				1,120	P
	Chemical Agent Alarm Mounting Kit	Install			4.0			1,120	P
	Fire Extinguisher Mounting Kit	Install		0.5				1,120	P
	Troop Seat Center Mounting Kit	Install		3.5				1,120	P
47	<b>GAGES (NON-ELECTRICAL)</b>								
4701	Speedometer	Inspect	0.1						A
		Replace		0.4				1	
	Tachometer	Inspect	0.1						A
		Replace		0.4				1	
4702	Gage, Air Pressure	Inspect	0.1						A
		Replace		0.5				1	
4705	Meter, Liquid	Inspect	0.1						A
		Replace			1.0			1	

## Section III. TOOL AND TEST EQUIPMENT REQUIREMENTS

(1) REFERENCE CODE	(2) MAINTENANCE CATEGORY	(3) NOMENCLATURE	(4) NATIONAL/NATO STOCK NUMBER	(5) TOOL NUMBER
1	OFHD	Tool Kit, General Mechanic's	5180-00-177-7033	SC5180-90-CL-N26
2	FHD	Shop Equipment, Welding Field Maintenance	3470-00-357-7268	SC4910-95-CL-A08
3	OFHD	Shop Equipment, Fuel and Electrical	4910-00-754-0714	SC4910-95-CL-A01
4	OFHD	Tool Kit, Fuel and Electrical	5180-00-754-0655	SC5180-95-CL-B08
5	FHD	Tool Kit, Glass Cutting	5180-00-357-7737	SC4990-95-CL-A18
6	FHD	Tool Kit, Body and Fender Repair	5180-00-754-0643	SC5180-90-CL-N34
7	OFHD	Replacer, Oil Seal: Front or Rear Wheel Hub Inner Oil Seal	5120-00-947-2232	10937827
8	OFHD	Wrench, Pulley Adjusting: Air Compressor Pulley	5120-00-070-7809	10935288
9	OFHD	Socket, Wrench, Face Spanner: Clutch Release Lever Adjusting Nut	5120-00-034-8443	8390124
10	FHD	Replacer, Gear: Crankshaft Gear	5120-00-870-6920	10899179
11	FHD	Expander, Piston Ring	5120-00-068-7234	P409S
12	FHD	Compressor, Piston Ring: Compressing or Gaging Piston Rings	5120-00-068-7238	10935313
13	FHD	Wrench, Box: Cylinder Head Nuts (Long)	5120-00-937-7834	10951484
14	FHD	Adapter, Cylinder Compression Tester: Checking Cylinder Compression (Used w/4910-00-870-6283 Gage Assembly)	4910-00-870-2127	10899183
15	FHD	Gage Assembly: Checking Cylinder Compression (Used w/4910-00-870-2127 Adapter)	4910-00-870-6283	10899180
16	HD	Stand, Maintenance, Automotive Engine: Engine Overhaul (Used w/4910-00-795-0198 Cradle)	4910-00-795-0189	7950189
17	HD	Cradle Assembly: Engine Universal (Used w/4910-00-795-0189 Stand)	4910-00-795-0198	7950198
18	HD	Bracket, Angle: Engine Mounting, Right and Left Front (Used w/4910-00-795-0198 and 4910-00-795-0189 Cradle and Stand) (2 Required per Operation)	5340-00-043-5264	10935299

## Section III. TOOL AND TEST EQUIPMENT REQUIREMENTS (Contd)

(1) REFERENCE CODE	(2) MAINTENANCE CATEGORY	(3) NOMENCLATURE	(4) NATIONAL/NATO STOCK NUMBER	(5) TOOL NUMBER
19	HD	Bracket, Double Angle: Engine Mounting Right Rear (Used w/4910-00-795-0198 and 4910-00-795-0189 Cradle and Stand)	5340-00-873-1926	10899188
20	HD	Bracket, Double Angle: Engine Mounting Left Rear (Used w/4910-00-795-0198 and 4910-00-795-0189 Cradle and Stand)	5340-00-873-1925	10912239
21	HD	Ram Kit, Hydraulic: Cylinder Sleeve Removal (Used w/5180-00-071-0736 Remover and Replacer)	4910-00-873-1927	10912249
22	HD	Tool Kit, Cylinder: Remove or Install Cylinder Sleeve (Used w/4910-00-873-1927 Ram Kit)	5180-00-071-0736	10935312
23	HD	Replacing Tool: Intake Valve Seat Insert	5120-00-134-7473	11642007
24	HD	Remover, Valve Guide: Removing or Installing Valve Guides (Used w/5120-00-870-6921 Replacer)	5120-00-871-3513	10899157
25	HD	Replacer, Valve Guide: Install Valve Guides (Used w/5120-00-871-3513 Remover)	5120-00-870-6921	10899158
26	FHD	Compressor Assembly, Valve: Compressing Valve Springs or Rotors while Engine is in Vehicle	5120-00-933-6057	10951361
27	FHD	Puller Kit, Mechanical: Crankshaft Pulley (Used w/5120-00-870-6914 Adapter: Crankshaft Gear, Camshaft Gear, Compressor or Water Pump Pulley)	5180-00-338-6721	8708724
28	FHD	Plug, Mechanical Puller (Used w/5120-00-338-6721 Puller) (Adapter)	5120-00-870-6914	10899178
29	FHD	Extractor, Screw, Threaded Insert: Helical Insert, Flywheel Housing	5120-00-723-6833	1227-6
30	HD	Replacing Tool, Engine: Exhaust Valve Seat Insert	5120-00-134-7480	11642006
31	HD	Reamer, Hand: Intake and Exhaust Valve Guides	5110-01-050-2240	12254220
32	HD	Replacer, Valve Guide (Used w/5120-00-871-3513 Valve Guide Remover)	5120-00-134-7461	11642004
33	HD	Remover and Replacer Kit, Bushing: Camshaft Bearings	5120-00-870-6919	10899154

## Section III. TOOL AND TEST EQUIPMENT REQUIREMENTS (Contd)

(1) REFERENCE CODE	(2) MAINTENANCE CATEGORY	(3) NOMENCLATURE	(4) NATIONAL/NATO STOCK NUMBER	(5) TOOL NUMBER
34	FHD	Extractor, Coil Threaded Insert: Helical Threaded Insert, Oil Filter (7/16- to 1- in. Thd Size)	5120-00-251-1527	7751056
35	FHD	Inserter, Screw Threaded Insert: Helical Threaded Insert, Oil Filter (1-14 Thd)	5120-00-204-0881	535-16
36	FH	Tester, Fuel Injector Nozzle	4910-00-255-8641	7551255
37	FHD	Crowfoot Attachment (Used for tightening injector line nuts at injection pump head)	5120-00-134-7459	11642001
38	H	Stand, Fuel Injector Test	4910-01-194-7667	DFP-156
39	HD	Fixture: Holding Camshaft	3040-00-870-2131	10899172
40	HD	Puller, Mechanical Bearing Plate: Spider Assembly (Used w/5120-00-793-5055 Remover and Replacer)	5120-00-793-5048	10882818
41	HD	Remover and Replacer Plunger Locks: Removing Camshaft from Housing: Replacing Bearing on Camshaft: Replacing Spider Weight Assembly on Camshaft: Removing Weight Assembly from Camshaft (Used w/5120-00-793-5048 Puller)	5120-00-793-5055	10882856
42	HD	Cap, Valve	4820-00-793-5040	10882854
43	FH	Gage Set, Pressure Dial Indicating: Fuel Pressure Test	4910-00-319-6195	5704365
44	HD	Adapter, Mechanical Puller: Reverse Idler Gear (Used w/5120-00-313-9496 Puller)	5120-00-708-3254	7083254
45	HD	Puller: Reverse Idler Gear (Used w/5120-00-708-3254 Adapter)	5120-00-313-9496	1178
46	HD	Stand, Engine Maintenance	4910-00-529-8387	171
47	HD	Bracket: (Adapting Right Side of Transfer Case to Stand 4910-00-529-8387)	5340-00-610-0920	7010363
48	HD	Bracket: (Adapting Left Side of Transfer Case to Stand 4910-00-529-8387)	5340-00-610-0919	7010362
49	FHD	Fixture, Transfer Case: Removing and/or Replacing Transfer Case with Lift 4910-00-422-8565	4910-00-694-4777	8708279

## Section III. TOOL AND TEST EQUIPMENT REQUIREMENTS (Contd)

(1) REFERENCE CODE	(2) MAINTENANCE CATEGORY	(3) NOMENCLATURE	(4) NATIONAL/NATO STOCK NUMBER	(5) TOOL NUMBER
50	HD	Remover and Replacer: Transfer Case Idler Shaft Front Bearing Cup (Used w/5340-00-708-3241 Handle)	5120-00-708-3247	7083247
51	FHD	Handle, Remover and Replacer (Used w/Removers and Replacers)	5340-00-708-3241	7083241
52	FH	Burnisher: Steering Knuckle Sleeve Bushing	5120-00-708-3237	7083237
53	OFHD	Screw, Remover and Replacer: (Used w/5120-00-473-7372 and 5120-00-708-3246 Remover and Replacer)	5120-00-708-3216	7083216
54	FHD	Remover and Replacer: Steering Gear Housing: Pitman Arm Shaft Bushing	5120-00-708-3248	7083248
55	HD	Puller Screw Type: Differential Spider Pinion Bushing	5120-00-836-6689	8366689
56	HD	Burnisher: Differential Spider Pinion Bushing	5120-00-708-3236	7083236
57	FHD	Replacer, Oil Seal: Differential Carrier Through Shaft Oil Seals (Used w/5340-00-708-3241 Handle)	5120-00-708-3256	7083256
58	FHD	Remover, Oil Seal: Differential Carrier Through Shaft Rear Oil Seal (Used w/5340-00-708-3241 Handle)	5120-00-708-3250	7083250
59	HD	Remover and Replacer, Bearing Sleeve: Differential Carrier Bevel Gear Bearing Sleeve (Used w/5120-00-708-3216 Screw)	5120-00-708-3246	7083246
60	OFHD	Gage Pressure, Dial, Indicating (Checking Air Brake Air Pressure)	6685-00-387-9654	216390
61	OFHD	Wrench, Socket: Wheel Stud Nut	5120-00-293-2452	7083293
62	FHD	Remover, Oil Seal: Differential Carrier Through Shaft Front Oil Seal (Used w/5340-00-708-3241 Handle)	5120-00-708-3249	7083249
63	OFHD	Fuel Pressure Gage: Fuel Pump (in-tank) Testing	4910-00-255-8673	E345
64	FHD	Crankshaft Driver	5120-00-134-7464	11642010
65	FHD	Replacer, Oil Seal: Front Crankshaft Oil Seal	5120-00-134-7481	11642003
66	FHD	Torx Socket: 60 amp Alternator	5120-01-227-3159	TLE60

## Section III. TOOL AND TEST EQUIPMENT REQUIREMENTS (Contd)

(1) REFERENCE CODE	(2) MAINTENANCE CATEGORY	(3) NOMENCLATURE	(4) NATIONAL/NATO STOCK NUMBER	(5) TOOL NUMBER
67	OFHD	Tool Kit, Electrical	5180-00-876-9336	7550526
68	OFHD	Multimeter	6625-00-999-6282	ANURM 105C
69	OFHD	Clutch Alinement Kit	5180-00-449-3785	A37M
70	OFHD	Plum Bob	5120-00-238-3299	MS15747- 8
71	FHD	Torque Wrench, 3/4-in. dr.	5120-01-118-3679	TESI800A
72	OFHD	Torque Wrench, 1/2-in. dr.	5120-00-640-6364	A-A-2411
73	FHD	Torque Wrench, 3/8-in. dr.	5120-00-230-6380	TE-12A
74	FHD	Caliper, Vernier	5210-01-113-1548	6420
75	FHD	1-1/8-in. Socket, 1/2-in. dr.	5120-00-189-7914	11677025- 10
76	FHD	1-1/16-in. Socket, 1/2-in. dr.	5120-00-189-7913	11677025- 8
77	FHD	Brake Reliner	4910-00-173-5310	MILR134 95TYICLI
78	OFHD	Soldering Iron	3439-00-542-0396	8200G3
79	OFHD	Sling	4910-00-944-4915	1806
80	OFHD	Bar, Breaker, 1/2-in. dr.	5120-00-224-1393	MLK7 101998-12
81	OFHD	Inside Micrometer	5120-00-221-1921	124B
82	FHD	Outside Micrometer	5210-00-554-7134	GGG-C-105 TYICLISTA
83	FHD	Adapter, 1/2-in. Male - 3/8-in. Female	5130-00-449-7698	SJ409- ZANDN02 DRIFT PIN
84	FHD	1-1/4-in. Socket, 1/2-in. dr.	5120-00-237-0977	5216
85	OFHD	Riveting Tool	5120-00-017-2849	250K
86	OFHD	Hydraulic Jack	4910-00-289-7233	93660
87	FHD	Indicator, Dial	5120-00-277-8840	196A

## Section III. TOOL AND TEST EQUIPMENT REQUIREMENTS (Contd)

(1) REFERENCE CODE	(2) MAINTENANCE CATEGORY	(3) NOMENCLATURE	(4) NATIONAL/NATO STOCK NUMBER	(5) TOOL NUMBER
88	OFHD	Mechanical Puller Kit	5120-00-423-1569	PE12
89	OFHD	Arbor Press	3444-00-449-7295	26A49
90	OFHD	Tape Measure	5210-00-234-6745	GGG-T- 106TY2 CLBCAV ST3
91	OFHD	Vise	5120-00-293-1439	504M2
92	FHD	1-5/16-in. Socket, 3/4-in. dr.	5120-00-232-5681	1242
93	OFHD	Wheel Alinement Indicator	4910-00-221-2472	AR40
94	FHD	1-1/8-in. Socket, 3/4-in. dr.	5120-00-239-0021	1818
95	FHD	Bar, Breaker, 3/4-in. dr.	5120-00-224-1393	NPB124
96	FHD	Handle, Socket Wrench, 3/4-in. dr.	5120-00-249-1076	1940708
97	FHD	1-1/4-in. Socket, 3/4-in. dr.	5120-00-235-5871	F3105A
98	FHD	Spring Tester	6635-00-641-7346	SPT
99	FHD	Pipe Wrench	5120-00-277-1486	TKCXIH
100	FHD	Snapping Pliers	5120-00-789-0492	4440R
101	FHD	1-1/2-in. Socket, 3/4-in. dr.	5120-00-293-0094	47148
102	OFHD	Lift, Transmission and Differential	4910-00-585-3622	9037-20BM
103	FHD	1-3/4-in. Socket, 1-in. dr.	5120-00-261-2837	8156
104	FHD	Handle, Socket Wrench, 1-in. dr.	5120-00-221-7968	14-906
105	FHD	11/16-in. Flare Wrench, 12 pt.	5120-00-224-3141	11655785-2
106	FHD	1-5/8-in. Socket, 3/4-in. dr.	5120-00-199-7765	5552
107	FHD	Handle, Socket Wrench, 3/4-in. dr.	5120-00-221-7959	5668
108	FHD	1/2-in. Allen Wrench	5120-00-198-5391	024-0067- 00
109	FHD	1-1/4-in. Open-End Wrench	5120-00-187-7134	1037
110	FHD	1-1/4-in. Box Wrench	5120-00-184-8677	GGG-W- 636
111	OFHD	Straightedge	6675-00-224-8807	564000-36

## Section III. TOOL AND TEST EQUIPMENT REQUIREMENTS (Contd)

(1) REFERENCE CODE	(2) MAINTENANCE CATEGORY	(3) NOMENCLATURE	(4) NATIONAL/NATO STOCK NUMBER	(5) TOOL NUMBER
112	FHD	Gage, Force, Mechanical	6670-00-254-4634	AAA-S-133
113	FHD	12-in. Extension, 3/8-in. dr.	5120-00-243-1691	35W198
114	OFHD	Universal Joint, 3/8-in. dr.	5120-00-224-9215	1060775
115	FHD	2-1/4-in. Socket, 1-in. dr.	5120-00-261-2843	B107.1 CLISTA
116	FHD	1-1/16-in. Socket, 3/4-in. dr.	5120-00-189-7928	A-A-1394
117	OFHD	Adjustable Wrench	5120-00-264-3793	2117080
118	OFHD	C, Clamp	5120-00-222-1612	A-A-431
119	OFHD	Puller, Mechanical	5120-00-423-1569	PE12
120	OFHD	Drill, Electric	4910-00-754-0650	SC-4910-95-CL-A72
121	OFHD	Remover and Replacer (Used w/ 5120-00-708-3216 and 5120-00-708-3246)	5120-00-473-7372	7082863



**Section IV. REMARKS**

REFERENCE CODE	REMARKS
A	Perform PMCS as shown in TM 9-2320-361-10.
B	Engine overhaul will be in accordance with DMWR 9-2815-500.
C	Welding will be in accordance with TM 9-237.
D	Repair of lines and fittings will be in accordance with TM 9-243.
E	Test and repair of radiator will be in accordance with TM 750-254.
F	Repair of alternator will be in accordance with TM 9-2920-225-34.
G	Repair of starter will be in accordance with TM 9-2920-243-34.
H	Repair of batteries will be in accordance with TM 9-6140-200-14.
I	Transmission repair and overhaul will be in accordance with TM 9-2520-246-34.
J	Transfer overhaul will be in accordance with TM 9-2320-246-34.
K	Overhaul of front and rear axle will be in accordance with DMWR 9-2520-508.
L	Tires/Tubes:            Repair                    TM 9-2610-200-24 Inspection                TM 9-2610-201-14 Storage                    TM 743-200-1
M	Repair of frames will be in accordance with TB 2300-247-40.
N	Metal body repair will be in accordance with TC 9-510.
O	Overhaul of front and rear winches will be in accordance with DMWR 9-3830-501.
P	Refer to kit installation instructions for kit installation.
Q	Inspection of brake lines will be in accordance with TB 9-2300-405-14.
R	Service/inspection of winch/hoist wire rope/cables will be in accordance with TB 43-0142 and TB 9-0352.
S	Repair of heaters will be in accordance with TM 9-2540-205-24&P.
T	Repair of canvas will be in accordance with TM 10-267.
U	Inspection and repair will be in accordance with TM 9-2815-210-34.
V	Inspection and repair of turbocharger will be in accordance with TM 9-2990-201-40&P.
W	Inspection and repair of brake drums will be in accordance with TM 9-4910-482-10.

## APPENDIX C

### EXPENDABLE/DURABLE SUPPLIES AND MATERIALS LIST

#### Section I. INTRODUCTION

##### **C-1. SCOPE**

This appendix lists expendable/durable supplies and materials you will need to maintain M44A2 series vehicles. This listing is for informational purposes only and is not authority to requisition listed items. These items are authorized to you by CTA 50-970, Expendable/Durable Items (except Medical, Class V, Repair Parts, and Heraldic Items), or CTA 8-100, Army Medical Department Expendable/Durable Items.

##### **C-2. EXPLANATION OF COLUMNS**

**a. Column (1) - Item Number.** This number is assigned to the entry in the listing and is referenced in the "INITIAL SETUP" of applicable tasks under the heading of "Materials/Parts."

**b. Column (2) - Level.** This column identifies the lowest level of maintenance that requires the listed item.

C - Operator/Crew  
O - Unit Maintenance

**c. Column (3) - National Stock Number.** This is the National stock number assigned to the item; use it to request or requisition the item

**d. Column (4) - Description.** This column indicates the Federal item name and, if required, a description to identify the item. The last line for each item indicates the Federal Supply Code for Manufacturer (FSCM) in parenthesis followed by the part number.

**e. Column (5) - Unit of Measure (U/M).** This column indicates the measure used in performing the actual maintenance function. This measure is expressed by a two-character alphabetical abbreviation (e.g.: EA, IN., PR). If the unit of measure differs from the unit of issue, requisition the lowest unit of issue that will satisfy your requirements. Adjust when higher category maintenance requirements are involved.

Section II. EXPENDABLE/DURABLE SUPPLIES AND MATERIALS LIST

(1) ITEM NUMBER	(2) LEVEL	(3) NATIONAL STOCK NUMBER	(4) DESCRIPTION	(5) U/M
1	O	8040-00-262-9028	ADHESIVE: reclaimed rubber (19023) 829899  1-Pint Can	PT
2	O	8040-00-262-9011	ADHESIVE: synthetic rubber, type III (91488) SRG 792  1-Pint Can	PT
3	O	8040-00-262-9005	ADHESIVE: natural rubber, type II, (81348) MMM-A-1617  1-Gallon Can	GL
4	O	8040-00-262-9026	ADHESIVE: reclaimed rubber, type I, (80244) MMM-A-1617 TY1  1/2-Pint Can	PT
5	O	8040-00-833-9563	ADHESIVE: sealant, silicone rubber, Silastic 732 RTV (clear) non-hardening, type I (80063) SM-C-773480-5 5 OZ  1 Kit	KT
6	C	6850-00-181-7929 6850-00-181-7933 6850-00-181-7940	ANTIFREEZE: permanent, ethylene glycol (-60°F (-51°C)) inhibited (O-A-548), heavy-duty (81349) MIL-A-46153  1-Gallon Container 5-Gallon Container 55-Gallon Drum	GL GL GL
7	O	9150-01-102-9455 9150-01-123-3152 9150-01-072-8379	BRAKE FLUID, AUTOMOTIVE: silicone, all weather, operational and preservative (81349) MIL-B-46176  1-Gallon Can 5-Gallon Can 55-Gallon Drum	GL GL GL
8	O	5340-00-450-5718	CAP AND PLUG SET: (19207) 10935405  1 Set	EA

## Section II. EXPENDABLE/DURABLE SUPPLIES AND MATERIALS LIST (Contd)

(1) ITEM NUMBER	(2) LEVEL	(3) NATIONAL STOCK NUMBER	(4) DESCRIPTION	(5) U/M
9	O	7510-00-164-8893	CHALK: marking, white (81348) SS-C-266  1 Gross	GR
10	O	6850-00-598-7328	CLEANING COMPOUND, ENGINE COOLING SYSTEM: (oxalic acid/borax inhibitor) (81349) MIL-C-10597  1 Kit	KT
11		8030-00-244-1297	CORROSION PREVENTIVE COMPOUND: grade 2, soft film (81349) MIL-C-16173 D grade 2  1-Gallon Can	GL
12	C	7930-00-282-9699	DETERGENT, GENERAL PURPOSE: nonsudsing, liquid, 1 gal. (80244) MIL-D-16791TY1	GL
13	C	9150-00-935-1017	GREASE, AUTOMOTIVE AND ARTILLERY: (81349) MIL-G-10924  14-Ounce Cartridge	OZ
		9150-00-190-0904	1-3/4-Pound Can	LB
		9150-00-190-0905	6-1/2-Pound Can	LB
14	O	9150-01-095-5512	GREASE: ball and roller bearing (73219) 18901  Case, 24/14-Ounce Cans	OZ
15	O	9150-00-257-5370	GREASE, GRAPHITE: hard, grade 1 (81348) VV-G-671  1-3/4-Pound Can	LB
		9150-00-235-5568	6-1/2-Pound Can	LB
		9150-00-272-7652	35-Pound Can	LB
16	O	6810-00-264-8983	METHYL ETHYL KETONE, TECHNICAL: (19207) 7527656  3-Ounce Bottle	OZ

Section II. EXPENDABLE/DURABLE SUPPLIES AND MATERIALS LIST (Contd)

(1) ITEM NUMBER	(2) LEVEL	(3) NATIONAL STOCK NUMBER	(4) DESCRIPTION	(5) U/M
17	C	9150-01-035-5392	OIL, LUBRICATING, GEAR: GO 80/90, multi-purpose (81349) MIL-L-2105 1-Quart Can	QT
		9150-01-035-5393	5-Gallon Drum	GL
		9150-01-035-5394	55-Gallon Drum	GL
18	C	9150-00-189-6727	OIL, LUBRICATING, ENGINE: OE/HDO 10 (81349) MIL-L-2104 1-Quart Can	QT
		9150-00-186-6668	5-Gallon Drum	GL
		9150-00-191-2772	55-Gallon Drum	GL
		9150-00-183-7807	Bulk	GL
19	C	9150-00-186-6681	OIL, LUBRICATING, ENGINE: OE/HDO 30, (15958) MIL-L-2104 1-Quart Can	QT
		9150-00-188-9858	5-Gallon Drum	GL
		9150-00-189-6729	55-Gallon Drum	GL
20	O	5975-00-570-9598	PLASTIC STRAP, TIEDOWN, ELECTRICAL COM- PONENTS: nylon, self-locking, type I, 10 inches long (96906) MS3367-7-9 1 Hundred	EA
21	C	7920-00-205-1711	RAG, WIPING: unbleached cotton and cotton-synthetic, mixed colors (58536) A-A-531 50-Pound Bale	EA
22	O	9505-00-684-4843	SAFETY WIRE (WIRE, NON-ELECTRICAL): (96906) MS20995-F41 1-Pound	PC
23	O	8030-00-148-9833	SEALING COMPOUND: anaerobic, type I, grade K (80244) MIL-S-46163 TY1GRK 10-Cubic Centimeter Bottle	CC

## Section II. EXPENDABLE/DURABLE SUPPLIES AND MATERIALS LIST (Contd)

(1) ITEM NUMBER	(2) LEVEL	(3) NATIONAL STOCK NUMBER	(4) DESCRIPTION	(5) U/M
24	O	8030-00-252-3391	SEALING COMPOUND: nonhardening gasket forming cement, type II (80064) 1756371  11-Ounce Tube	OZ
25	O	8030-00-965-2438	SEALING COMPOUND: tape form, type III (80244) MIL-S-11030  60-Foot Roll	FT
26	C	6850-00-110-4498	SOLVENT, DRYCLEANING: type II (81348) P-D-680, ASTM D235-87  1-Pint Can	PT
		6850-00-274-5421	5-Gallon Drum	GL
		6850-00-285-8011	55-Gallon Drum	GL
		6850-00-637-6135	Bulk	GL
27	O	8030-00-889-3535	TAPE, ANTISEIZING: white, 0.5-in. wide x 260 in. long x 0.0035 in. thick, with snap on shell (81755) P5025-2R, MIL-T-27730  1 Each (Spool)	EA
28	O	5970-00-419-4291	TAPE, INSULATION, ELECTRICAL: (75037) 17 3-4 IN BLACK  108-Foot Roll	FT
29	O	5610-01-019-4180	TAR, COAL: (64247) liquid damp-dek  5-Gallon Drum	GL
30	O	6810-00-678-4418	TRICHLOROETHYLENE, TECHNICAL: (81348) O-T-634  1-Gallon	GL
		6810-00-184-4794	5-Gallon	GL
		6810-00-184-4800	55-Gallon Drum	GL



## APPENDIX D TORQUE LIMITS

### D-1. GENERAL

This section provides general torque limits for screws used on the M44A2 series vehicles. Special torque limits are indicated in the maintenance procedures for applicable components. The general torque limits given in this appendix shall be used when specific torque limits are not indicated in the maintenance procedure. These general torque limits cannot be applied to screws that retain rubber components. The rubber components will be damaged before the correct torque limit is reached. If a special torque limit is not given in the maintenance instructions, tighten the screw or nut until it touches the metal bracket then tighten it one more turn.

### D-2. TORQUE LIMITS

Table D-1 lists dry torque limits. Dry torque limits are used on screws that do not have lubricants applied to the threads. Table D-2 lists wet torque limits. Wet torque limits are used on screws that have high pressure lubricants applied to the threads.

### D-3. HOW TO USE TORQUE TABLE

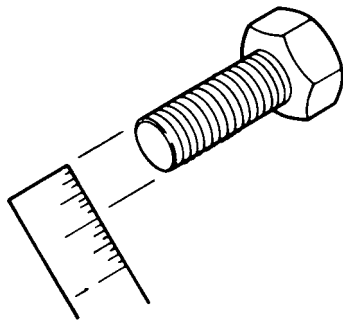

- a. Measure the diameter of the screw you are installing.

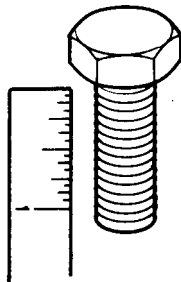

- b. Count the number of threads per inch.

- c. Under the heading **SIZE**, look down the left hand column until you find the diameter of the screw you are installing (there will usually be two lines beginning with the same size).
- d. In the second column under **SIZE**, find the number of threads per inch that matches the number of threads you counted in step b.

#### CAPSCREW HEAD MARKINGS

Manufacturer's marks may vary.  
These are all SAE Grade 5  
(3-line).



- e. To find the grade screw you are installing, match the markings on the head to the correct picture of **CAPSCREW HEAD MARKINGS** on the torque table.
- f. Look down the column under the picture you found in step e. until you find the torque limit (in lb-ft or N·m) for the diameter and threads per inch of the screw.



Table D-1. Torque Limits for Dry Fasteners.

CAPSCREW HEAD MARKINGS

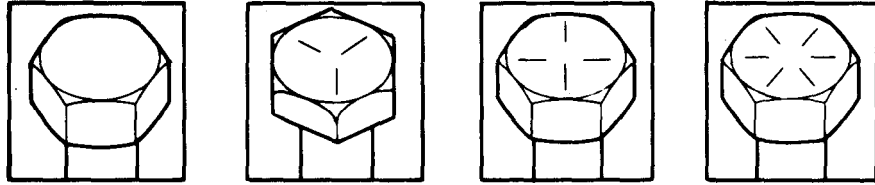

SIZE			TORQUE							
			SAE GRADE NO. 1 or 2		SAE GRADE NO. 5		SAE GRADE NO.6 or 7		SAE GRADE NO. 8	
DIA. INCHES	THREADS PER INCH	MILLIMETERS	POUND FEET	NEWTON METERS	POUND FEET	NEWTON METERS	POUND FEET	NEWTON METERS	POUND FEET	NEWTON METERS
1/4	20	6.35	5	6.78	8	10.85	10	13.56	12	16.27
1/4	28	6.35	6	8.14	10	13.56	-	-	14	18.98
5/16	18	7.94	11	14.92	17	23.05	19	25.76	24	32.54
5/16	24	7.94	13	17.63	19	25.76	-	-	27	36.61
3/8	16	9.53	18	24.41	31	42.04	34	46.10	44	59.66
3/8	24	9.53	20	27.12	35	47.46	-	-	49	66.44
7/16	14	11.11	28	37.97	49	66.44	55	74.58	70	94.92
7/16	20	-	30	40.68	55	74.58	-	-	78	105.77
1/2	13	12.70	39	52.88	75	101.70	85	115.26	105	142.38
1/2	20	-	41	55.60	85	115.26	-	-	120	162.72
9/16	12	14.29	51	69.16	110	149.16	120	162.72	155	210.18
9/16	18	-	55	74.58	120	162.72	-	-	170	230.52
5/8	11	15.88	63	85.43	150	203.40	167	226.45	210	284.76
5/8	18	-	95	128.82	170	230.52	-	-	240	325.44
3/4	10	19.05	105	142.38	270	366.12	280	379.68	375	508.50
3/4	16	-	115	155.94	295	400.02	-	-	420	569.52
7/8	9	22.23	160	216.96	395	535.62	440	596.64	605	820.38
7/8	14	-	175	237.30	435	589.86	-	-	675	915.30
1	8	25.40	235	318.66	590	800.04	660	894.96	910	1233.96
1	14	-	250	339.00	660	894.96	-	-	990	1342.44
1-1/8	-	28.58	-	-	800-880	1084.8-1193.3	-	-	1280-1440	1735.7-1952.6
1-1/4	-	31.75	-	-	-	-	-	-	1820-2000	2467.9-2712.0
1-3/8	-	34.93	-	-	1460-1680	1979.8-2278.1	-	-	2380-2720	3227.3-3688.3
1-1/2	-	38.10	-	-	1940-2200	2630.6-2983.2	-	-	3160-3560	4285.0-4827.4

Table D-2. Torque Limits for Wet Fasteners.

CAPSCREW HEAD MARKINGS

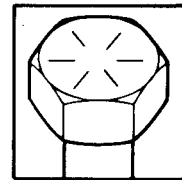
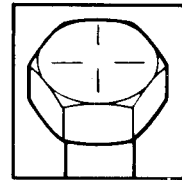
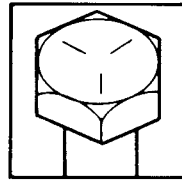
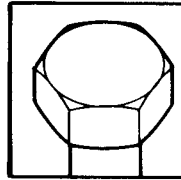

SIZE			TORQUE							
			SAE GRADE NO. 1 or 2		SAE GRADE NO. 5		SAE GRADE NO. 6 or 7		SAE GRADE NO. 8	
DIA. INCHES	THREADS PER INCH	MILLIMETERS	POUND NEWTON FEET	POUND NEWTON METERS	POUND NEWTON FEET	POUND NEWTON METERS	POUND NEWTON FEET	POUND NEWTON METERS	POUND NEWTON FEET	POUND NEWTON METERS
1/4	20	6.35	4.9	6.6	7.2	9.76	9.0	12.20	10.8	14.64
1/4	28	6.35	5.4	7.32	9.0	12.20	-	-	12.6	17.09
5/16	18	7.94	9.9	13.42	15.3	20.75	17.1	23.19	21.6	29.29
5/16	24	7.94	11.7	15.87	17.1	23.19	-	-	24.3	32.95
3/8	16	9.53	16.2	21.97	27.9	37.83	30.6	41.49	39.6	53.70
3/8	24	9.53	18.0	24.41	31.5	42.71	-	-	44.1	59.80
7/16	14	11.11	25.2	34.17	44.1	59.80	49.5	67.12	63.0	85.43
7/16	20	-	27.0	36.61	49.5	67.12	-	-	70.2	95.19
1/2	13	12.70	35.1	47.60	67.5	91.53	76.5	103.73	94.5	128.14
1/2	20	-	36.9	50.04	76.5	103.73	-	-	108.0	146.45
9/16	12	14.29	45.9	62.24	99.0	134.24	108.0	146.45	139.5	189.16
9/16	18	-	49.5	67.12	108.0	146.45	-	-	153.0	207.47
5/8	11	15.88	56.7	76.89	135.0	183.06	150.3	203.81	189.0	256.28
5/8	18	-	85.5	115.94	153.0	207.47	-	-	216.0	292.90
3/4	10	19.05	94.5	128.14	243.0	329.51	252.0	341.71	337.5	457.65
3/4	16	-	103.5	140.35	265.5	360.02	-	-	378.0	512.57
7/8	9	22.23	144.0	195.26	355.5	482.06	396.0	536.98	544.5	738.34
7/8	14	-	157.5	213.57	391.5	530.87	-	-	607.5	823.77
1	8	25.40	211.5	286.79	531.0	720.04	594.0	805.46	819.0	1110.56
1	14	-	225.0	305.10	594.0	805.46	-	-	891.0	1208.20
1-1/8	-	28.58	-	-	720.0-792.0	976.32-1073.95	-	-	1152.0-1296.0	1562.11-1757.38
1-1/4	-	31.75	-	-	-	-	-	-	1638.0-1800.0	2221.13-2440.80
1-3/8	-	34.93	-	-	1314.0-1512.0	1781.78-2050.27	-	-	2142.0-2448.0	2904.55-3319.49
1-1/2	-	38.10	-	-	1746.0-1980.0	2367.58-2684.88	-	-	2844.0-3204.0	3856.5-4344.62

**APPENDIX D (Contd)**

*Tubing Application Tightening Assembly Instructions*

Slide tubing over barbed insert until it bottoms on fitting.

**MINI-BARB**



1. Slide nut and then sleeve on tubing.
2. Slide I.D. of tubing onto fitting insert until it bottoms.
3. Assemble nut to fitting body.
4. Tighten assembly finger tight to cover body threads.

**KNURL-ON**

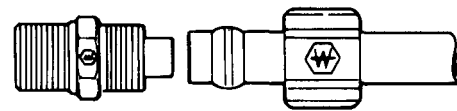

1. Slide nut and then sleeve on tubing.
2. Slide I.D. of tubing onto fitting insert until it bottoms.
3. Assemble nut to fitting body.
4. Tighten nut finger tight. From that point, tighten with a wrench two complete turns.

**SELF-ALINE-PTF**

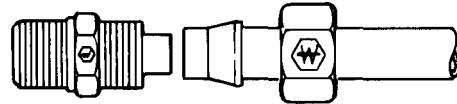

1. Cut tubing to desired length. Ensure ends are cut reasonably square.
2. Slide tubing into the preassembled fitting and push until tube bottoms.
3. Tighten nut as indicated in chart. Another check on proper assembly is dimension "A", when nut is fully tightened.

**NYLON TUBING FOR AIRBRAKE**

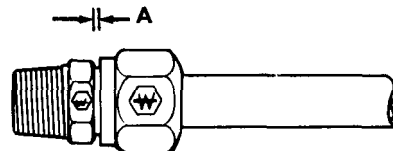

**DISASSEMBLY** - Remove nut and pull tubing out of fitting body. Insert will remain in tubing.

**REASSEMBLY** - Push tubing and insert into fitting body until it bottoms. Thread nut onto fitting body and tighten as in step 3.

TUBE O.D.	TIGHTEN NUT TO:	A
1/4	85-115 lb-in. (9.6 - 13.0 N·m)	.085/.105
3/8	12-17 lb-ft (16.3 - 23.1 N·m)	.125/.145
1/2	25-33 lb-ft (33.9 - 44.7 N·m)	.100/.120
5/8	26-35 lb-ft (35.3 - 47.5 N·m)	.115/.135
3/4	38-50 lb-ft (51.5 - 67.8 N·m)	.180/.200

**APPENDIX D (Contd)**

*Tubing Application Tightening Assembly Instructions (Contd)*

1. Slide nut and then sleeve on tubing. Threaded end of nut (C) must face out.
2. Insert tubing into fitting. Be sure tubing is bottomed on fitting shoulder.
3. Thread nut onto fitting body until it is hand tight.
4. From that point, tighten with a wrench the number of turns indicated at right.

**COPPER TUBING  
FOR AIRBRAKE**

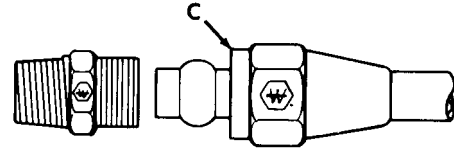

TUBE SIZE	ADDITIONAL NUMBER OF TURNS FROM HAND TIGHT
1/4, 3/8	1-3/4
1/2, 5/8, 3/4	3-1/4



**APPENDIX E**  
**SCHEMATIC AND WIRING DIAGRAMS**

TITLE	PAGE NO.
Foldout 1. Electrical System Wiring Diagram	FP-1
Foldout 2. Van Body Electrical System Wiring Diagram	FP-3
Foldout 3. Hydraulic Brake System Diagram	FP-5
Foldout 4. Compressed Air System M756A2	FP-7
Foldout 4. Compressed Air System M35A2C	FP-7
Foldout 4. Compressed Air System M109A3	FP-7
Foldout 4. Compressed Air System M185A3	FP-7
Foldout 4. Compressed Air System M35A2	FP-7
Foldout 4. Compressed Air System M50A3 and M50A2	FP-7
Foldout 4. Compressed Air System M49A2C	FP-7
Foldout 4. Compressed Air System M36A2	FP-7
Foldout 5. Compressed Air System M342A2	FP-9
Foldout 6. Compressed Air System M764	FP-11
Foldout 7. Compressed Air System M275A2	FP-13



INDEX

	Para	Page		Para	Page
<b>A</b>					
Absorber, shock, replacement:			Air cleaner cap and element replacement:		
Installation . . . . .	7-20b	7-46	Cap installation . . . . .	3-14d	3-23
Removal . . . . .	7-20a	7-46	Cap removal . . . . .	3-14a	3-22
Accelerator pedal, brackets, and rod maintenance:			Element installation . . . . .	3-14c	3-23
Adjustment . . . . .	3-33c	3-74	Element removal . . . . .	3-14b	3-22
Installation . . . . .	3-33b	3-72	Air cleaner indicator and tube maintenance:		
Removal . . . . .	3-33a	3-70	Inspection and cleaning . . . . .	3-16c	3-26
Access door moulding and access plate replacement:			Installation . . . . .	3-16d	3-26
Installation . . . . .	12-74b	12-121	Removal . . . . .	3-16b	3-26
Removal . . . . .	12-74a	12-121	Testing . . . . .	3-16a	3-25
Accessory switch replacement:			Air compressor and pulley replacement:		
Installation . . . . .	4-21b	4-36	Assembly . . . . .	8-26c	8-64
Removal . . . . .	4-21a	4-36	Disassembly . . . . .	8-26b	8-64
Adapter and speedometer drive-shaft replacement:			Installation . . . . .	8-26d	8-64
Speedometer adapter installation . . . . .	4-16c	4-30	Removal . . . . .	8-26a	8-62
Speedometer adapter removal . . . . .	4-16b	4-30	Air compressor drivebelt replacement:		
Speedometer shaft installation . . . . .	4-16d	4-30	Adjustment . . . . .	8-28c	8-68
Speedometer shaft removal . . . . .	4-16a	4-30	Installation . . . . .	8-28b	8-68
A-frame kit replacement:			Removal . . . . .	8-28a	8-68
Inspection . . . . .	14-41b	14-68	Air compressor governor maintenance:		
Installation . . . . .	14-41c	14-68	Check and adjustment . . . . .	8-29c	8-72
Removal . . . . .	14-41a	14-66	Installation . . . . .	8-29b	8-70
Airbrake cutoff valves and couplings replacement (M275A2, M342A2)			Removal . . . . .	8-29a	8-70
Installation . . . . .	8-33b	8-80	Air compressor servicing:		
Removal . . . . .	8-33a	8-80	Assembly . . . . .	8-27d	8-66
Airbrake cutoff valves and couplings replacement (M764):			Cleaning . . . . .	8-27c	8-66
Installation . . . . .	8-32b	8-78	Disassembly . . . . .	8-27b	8-66
Removal . . . . .	8-32a	8-78	Installation . . . . .	8-27e	8-67
Airbrake cutoff valves and couplings replacement:			Removal . . . . .	8-27a	8-66
Installation . . . . .	8-31b	8-76	Air horn, solenoid, and bracket replacement:		
Removal . . . . .	8-31a	8-76	Air horn installation . . . . .	4-31c	4-48
Airbrake hand control valve replacement:			Airhorn removal . . . . .	4-31b	4-48
Installation . . . . .	8-21b	8-48	Solenoid installation . . . . .	4-31d	4-48
Removal . . . . .	8-21a	8-48	Solenoid removal . . . . .	4-31a	4-48
Airbrake hose replacement:			Air-hydraulic cylinder replacement:		
Installation . . . . .	8-34b	8-82	Installation . . . . .	8-11b	8-31
Removal . . . . .	8-34a	8-82	Removal . . . . .	8-11a	8-30
Airbrake valve replacement:			Air inlet duct, primary heater replacement:		
Installation . . . . .	8-22b	8-50	Installation . . . . .	14-31b	14-47
Removal . . . . .	8-22a	8-50	Removal . . . . .	14-31a	14-47
Air cleaner assembly maintenance:			Air intake tube and cap replacement:		
Inspection . . . . .	3-15b	3-24	Installation . . . . .	3-13b	3-20
Installation . . . . .	3-15c	3-24	Removal . . . . .	3-13a	3-20
Removal . . . . .	3-15a	3-24			



INDEX (Contd)

	Para	Page		Para	Page
Air intake tubes replacement:			Alternator cable, 100 amp, and harness replacement:		
Installation . . . . .	14-38b	14-60	Installation . . . . .	14-51b	14-88
Removal . . . . .	14-38a	14-60	Removal . . . . .	14-51a	14-88
Air pressure gage replacement:			Alternator regulator, 100 amp, replacement:		
Installation . . . . .	4-11b	4-20	Installation . . . . .	14-52b	14-90
Removal . . . . .	4-11a	4-20	Removal . . . . .	14-52a	14-90
Air pressure switch, front-wheel drive lock-in switch indicator:			Alternator, 100 amp, replacement:		
Installation . . . . .	4-36b	4-54	Installation . . . . .	14-50b	14-86
Removal . . . . .	4-36a	4-54	Removal . . . . .	14-50a	14-86
Air pressure switch, stoplight replacement (M275A2):			Alternator pulley replacement:		
Installation . . . . .	4-32b	4-50	Installation . . . . .	4-4b	4-8
Removal . . . . .	4-32a	4-50	Removal . . . . .	4-4a	4-8
Air reservoirs replacement			Appendix A, references:		
Installation . . . . .	8-24b	8-56	Army regulations . . . . .	A-8	A-3
Removal . . . . .	8-24a	8-54	Common table of allowances . . . . .	A-10	A-3
Air reservoirs replacement (M275A2 and M342A2):			Forms . . . . .	A-3	A-1
Installation . . . . .	8-23b	8-52	Field manuals . . . . .	A-4	A-1
Removal . . . . .	8-23a	8-52	Other publications . . . . .	A-7	A-3
Air reservoirs replacement (M764):			Publications index . . . . .	A-2	A-1
Installation . . . . .	8-25b	8-60	Scope . . . . .	A-1	A-1
Removal . . . . .	8-25a	8-60	Technical bulletins . . . . .	A-6	A-2
Air system, compressed, maintenance, general . . . . .	8-17	8-45	Technical catalog . . . . .	A-9	A-3
Air system safety valve replacement:			Technical manuals . . . . .	A-5	A-2
Installation . . . . .	8-20b	8-47	Appendix B, maintenance allocation chart:		
Removal . . . . .	8-20a	8-47	Explanation of columns in the MAC . . . . .	B-3	B-2
Air tubes, windshield wiper motor, replacement:			Explanation of columns in remarks . . . . .	B-5	B-2
Installation . . . . .	11-33b	11-67	Explanation of columns in tool and test equipment requirements . . . . .	B-4	B-2
Removal . . . . .	11-33a	11-67	General . . . . .	B-1	B-1
Air vent, personnel heater, replacement:			Maintenance allocation chart . . . . .		B-3
Installation . . . . .	11-40b	11-77	Maintenance functions . . . . .	B-2	B-1
Removal . . . . .	11-40a	11-77	Remarks . . . . .		B-27
Alcohol evaporator replacement:			Tool and test equipment requirements . . . . .		B-19
Installation . . . . .	14-15b	14-22	Appendix C, expendable/durable supplies and materials list:		
Removal . . . . .	14-15a	14-22	Scope . . . . .	C-1	C-1
Alternator belts maintenance:			Explanation of columns . . . . .	C-2	C-1
Inspection . . . . .	4-2b	4-2	Appendix D, torque limits:		
Installation and adjustment . . . . .	4-2c	4-2	How to use torque table . . . . .	D-3	D-1
Removal . . . . .	4-2a	4-2	General . . . . .	D-1	D-1
Alternator, (60 amp), and mounting bracket replacement:			Torque limits . . . . .	D-2	D-1
Adjustment . . . . .	4-3c	4-6	Appendix E, schematic and wiring diagrams . . . . .		E-1
Installation . . . . .	4-3b	4-6			
Removal . . . . .	4-3a	4-4			

INDEX (Contd)

	Para	Page		Para	Page
Arm, pitman, replacement:			Battery box heater pad replacement:		
Installation . . . . .	9-8b	9-14	Installation . . . . .	14-11b	14-16
Removal . . . . .	9-8a	9-14	Removal . . . . .	14-11a	14-16
Assembly, windshield, maintenance:			Battery cables and clamps replacement:		
Assembly . . . . .	11-20c	11-32	Battery-to-battery cable installation . . . . .	4-48i	4-74
Disassembly . . . . .	11-20b	11-30	Battery-to-battery cable removal . . . . .	4-48d	4-74
Installation . . . . .	11-20d	11-32	Battery clamps installation . . . . .	4-48g	4-74
Removal . . . . .	11-20a	11-30	Battery clamps removal . . . . .	4-48f	4-74
Automatic brake test and adjustment:			Ground cable connection . . . . .	4-48b	4-73
Adjustment . . . . .	13-4b	13-6	Ground cable disconnection . . . . .	4-48a	4-73
Testing . . . . .	13-4a	13-4	Ground cable installation . . . . .	4-48j	4-74
Auxiliary duct, primary heater, replacement:			Ground cable removal . . . . .	4-48c	4-74
Installation . . . . .	14-34b	14-54	Positive cable installation . . . . .	4-48h	4-74
Removal . . . . .	14-34a	14-54	Positive cable removal . . . . .	4-48e	4-74
Auxiliary roller replacement:			Battery system, table 2-4:		
Installation . . . . .	12-101b	12-167	Electrical troubleshooting . . . . .		2-77
Removal . . . . .	12-101a	12-167	Bearing, wheel, adjustment . . . . .	9-5	9-11
Axle breather, front and rear, maintenance:			Belts, alternator, maintenance:		
Cleaning . . . . .	7-8b	7-21	Inspection . . . . .	4-2b	4-2
Installation . . . . .	7-8c	7-21	Installation and adjustment . . . . .	4-2c	4-2
Removal . . . . .	7-8a	7-21	Removal . . . . .	4-2a	4-2
Axle shaft flange, front, maintenance:			Blackout drive lamp and housing replacement:		
Cleaning and inspection . . . . .	7-10b	7-24	Blackout drive lamp housing installation . . . . .	4-42c	4-64
Installation . . . . .	7-10c	7-25	Blackout drive lamp housing removal . . . . .	4-42b	4-64
Removal . . . . .	7-10a	7-24	Blackout drive lamp installation . . . . .	4-42d	4-64
Axle shaft, rear, maintenance:			Blackout drive lamp removal . . . . .	4-42a	4-64
Cleaning and inspection . . . . .	7-11b	7-26	Blackout switch maintenance:		
Installation . . . . .	7-11c	7-26	Assembly . . . . .	12-80c	12-128
Removal . . . . .	7-11a	7-26	Disassembly . . . . .	12-80b	12-128
			Installation . . . . .	12-80d	12-128
			Removal . . . . .	12-80a	12-128
			Blower motor exhaust and bracket replacement:		
<b>B</b>			Installation . . . . .	12-60b	12-97
Battery and battery box maintenance index . . . . .	4-47	4-72	Removal . . . . .	12-60a	12-97
Battery and battery box replacement and servicing:			Blower motor receptacle replacement:		
Batteries and battery box installation . . . . .	4-49e	4-78	Installation . . . . .	12-79b	12-127
Batteries and battery box removal . . . . .	4-49a	4-76	Removal . . . . .	12-79a	12-127
Battery and battery box servicing . . . . .	4-49c	4-77	Blower switch, exhaust, replacement:		
Battery box support installation . . . . .	4-49d	4-78	Installation . . . . .	12-68b	12-110
Battery box support removal . . . . .	4-49b	4-76	Removal . . . . .	12-68a	12-110
Battery and generator gage, oil pressure gage, fuel gage, and engine temperature gage replacement:			Boarding ladder, vehicle, replacement:		
Installation . . . . .	4-12b	4-22	Installation . . . . .	12-66b	12-106
Removal . . . . .	4-12a	4-22	Removal . . . . .	12-66a	12-106
			Bracket, headlight, replacement:		
			Installation . . . . .	11-12b	11-18
			Removal . . . . .	11-12a	11-18

INDEX (Contd)

	Para	Page		Para	Page
Brackets, accelerator pedal, and rod maintenance:			Breaker, 24 V circuit, replacement:		
Adjustment . . . . .	3-33c	3-74	Installation . . . . .	12-65b	12-100
Installation . . . . .	3-33b	3-72	Removal . . . . .	12-65a	12-100
Removal . . . . .	3-33a	3-70	Breather, transfer case, maintenance:		
Brackets and mirror replacement:			Cleaning . . . . .	6-5b	6-20
Installation . . . . .	11-36b	11-72	Installation . . . . .	6-5c	6-20
Removal . . . . .	11-36a	11-72	Removal . . . . .	6-5a	6-20
Brackets, radiator, and replacement:			Breather, transmission, maintenance:		
Installation . . . . .	3-42b	3-98	Cleaning . . . . .	5-2b	5-2
Removal . . . . .	3-42a	3-96	Installation . . . . .	5-2c	5-2
Brake cable, parking, replacement:			Removal . . . . .	5-2a	5-2
Installation . . . . .	8-4b	8-14	Breather tube adapter, crankcase, replacement:		
Removal . . . . .	8-4a	8-12	Installation . . . . .	3-8b	3-13
Brakedrum, parking, replacement:			Removal . . . . .	3-8a	3-13
Installation . . . . .	8-2b	8-2	Breather tube, crankcase, maintenance:		
Removal . . . . .	8-2a	8-2	Cleaning and inspection . . . . .	3-6b	3-8
Brake lever, parking, replacement:			Installation . . . . .	3-6c	3-8
Installation . . . . .	8-5b	8-16	Removal . . . . .	3-6a	3-8
Removal . . . . .	8-5a	8-16	Brush guard, stone shield, and headlight guard replacement:		
Brake line, hydraulic, adjustment:			Brushguard installation . . . . .	10-8e	10-11
Installation . . . . .	8-15b	8-40	Brushguard removal . . . . .	10-8b	10-10
Removal . . . . .	8-15a	8-40	Headlight guard installation . . . . .	10-8d	10-11
Brake hose mast, trailer, replacement:			Headlight guard removal . . . . .	10-8c	10-10
Installation . . . . .	8-37b	8-88	Stone shield installation . . . . .	10-8f	10-11
Removal . . . . .	8-37a	8-88	Stone shield removal . . . . .	10-8a	10-10
Brake pedal adjustment . . . . .	8-14	8-38	Bumperette, rear, replacement:		
Brake pedal lever replacement:			Installation . . . . .	10-6b	10-7
Installation . . . . .	8-13b	8-36	Removal . . . . .	10-6a	10-7
Removal . . . . .	8-13a	8-36	Bumper, front spring, replacement:		
Brake, service, adjustment . . . . .	8-8	8-22	Installation . . . . .	7-15b	7-34
Brake, service, bleeding:			Removal . . . . .	7-15a	7-34
Manual method . . . . .	8-12b	8-34	Bumper, front, replacement:		
Pressure tank method . . . . .	8-12a	8-32	Installation . . . . .	10-9b	10-12
Brakeshoe, parking, maintenance:			Removal . . . . .	10-9a	10-12
Assembly . . . . .	8-3d	8-8	Bumper step kit replacement:		
Clearance adjustment . . . . .	8-3f	8-10	Installation . . . . .	14-48b	14-84
Cleaning and inspection . . . . .	8-3c	8-6	Removal . . . . .	14-48a	14-84
Disassembly . . . . .	8-3b	8-6	Button, horn, replacement:		
Installation . . . . .	8-3e	8-8	Installation . . . . .	4-30b	4-46
Removal . . . . .	8-3a	8-4	Removal . . . . .	4-30a	4-46
Brakeshoes, service, maintenance:			Buzzer, low air, replacement:		
Cleaning and inspection . . . . .	8-7b	8-20	Installation . . . . .	4-27b	4-42
Installation . . . . .	8-7c	8-20	Removal . . . . .	4-27a	4-42
Removal . . . . .	8-7a	8-19			
Brake system, compressed air and, troubleshooting:			<b>C</b>		
General . . . . .	2-13	2-52	Cab cowl vent replacement:		
Brake test, automatic, and adjustment:			Installation . . . . .	11-17b	11-26
Adjustment . . . . .	13-4b	13-6	Removal . . . . .	11-17a	11-26
Testing . . . . .	13-4a	13-4	Cab door and hinges replacement:		
Breaker, circuit, replacement:			Cab door hinges installation . . . . .	11-4c	11-4
Installation . . . . .	4-33b	4-51	Cab door hinges removal . . . . .	11-4b	11-4
Removal . . . . .	4-33a	4-51	Cab door installation . . . . .	11-4d	11-4
			Cab door removal . . . . .	11-4a	11-4

INDEX (Contd)

	Para	Page		Para	Page
Cab door catch replacement:			Cab handle replacement:		
Installation . . . . .	11-9b	11-13	Installation . . . . .	11-16b	11-25
Removal . . . . .	11-9a	11-13	Removal . . . . .	11-16a	11-25
Cab door check rod replacement:			Cable, 100 amp alternator, and		
Installation . . . . .	11-8b	11-12	harness replacement:		
Removal . . . . .	11-8a	11-12	Installation . . . . .	14-51b	14-88
Cab door dovetail wedge			Removal . . . . .	14-51a	14-88
replacement:			Cable, rear winch, replacement		
Installation . . . . .	11-3b	11-3	(M756A2):		
Removal . . . . .	11-3a	11-3	Installation . . . . .	13-13b	13-23
Cab door glass and weatherseal			Removal . . . . .	13-13a	13-23
replacement:			Cable, engine stop control,		
Cab door glass adjustment . . . . .	11-5c	11-6	maintenance:		
Installation . . . . .	11-5b	11-6	Adjustment . . . . .	3-34c	3-76
Removal . . . . .	11-5a	11-6	Installation . . . . .	3-34b	3-76
Cab door inspection hole cover			Removal . . . . .	3-34a	3-76
replacement:			Cable, front winch, replacement:		
Installation . . . . .	11-2b	11-2	Installation . . . . .	13-3b	13-3
Removal . . . . .	11-2a	11-2	Removal . . . . .	13-3a	13-3
Cab door lock, outside door handle,			Cable, speed control, maintenance:		
inside door handle, and,			Adjustment . . . . .	12-54d	12-89
replacement:			Inspection . . . . .	12-54b	12-88
Cab door lock installation . . . . .	11-7d	11-10	Installation . . . . .	12-54c	12-88
Cab door lock removal . . . . .	11-7c	11-10	Removal . . . . .	12-54a	12-88
Inside door handle installation. . . . .	11-7e	11-10	Cab mount, rear, replacement:		
Inside door handle removal . . . . .	11-7b	11-10	Installation . . . . .	11-23b	11-38
Outside door handle			Removal . . . . .	11-23a	11-38
installation . . . . .	11-7f	11-10	Cab protector replacement (M764):		
Outside door handle removal . . . . .	11-7a	11-10	Cab protector installation . . . . .	12-84d	12-135
Cab door weatherseals replacement:			Cab protector removal . . . . .	12-84a	12-133
Cab door head weatherseal			Mounting tubes installation . . . . .	12-84c	12-134
installation . . . . .	11-10e	11-14	Mounting tubes removal . . . . .	12-84b	12-134
Cab door head weatherseal			Cab protector, pipeline construction,		
removal . . . . .	11-10b	11-14	replacement:		
Cab door pillar posts weather-			Installation . . . . .	12-105b	12-172
seals installation . . . . .	11-10d	11-14	Removal . . . . .	12-105a	12-172
Cab door pillar posts weather-			Cab protector wiring harness		
seals removal . . . . .	11-10c	11-14	replacement (M756A2):		
Cab door weatherseals			Installation . . . . .	4-52b	4-82
installation . . . . .	11-10f	11-15	Removal . . . . .	4-52a	4-82
Cab door weatherseals			Cab soft top turnbuttons and		
removal . . . . .	11-10a	11-14	lashing hooks replacement:		
Cab door window regulator and			Lashing hooks installation . . . . .	11-25c	11-41
handle replacement:			Lashing hooks removal . . . . .	11-25b	11-41
Cab door window regulator			Turnbuttons and snap shank		
installation . . . . .	11-6c	11-8	installation . . . . .	11-25d	11-41
Cab door window regulator			Turnbuttons and snap shank		
removal . . . . .	11-6b	11-8	removal . . . . .	11-25a	11-41
Window regulator handle			Cab tunnel, rear tunnel, and		
installation . . . . .	11-6d	11-8	toeboard replacement:		
Window regulator handle			Rear tunnel installation . . . . .	11-22e	11-36
removal . . . . .	11-6a	11-8	Rear tunnel removal . . . . .	11-22b	11-36

INDEX (Contd)

	Para	Page		Para	Page
Toeboard installation . . . . .	11-22d	11-36	Cargo body rack and troop seat maintenance:		
Toeboard removal . . . . .	11-22c	11-36	Cargo rack assembly . . . . .	12-2f	12-2
Tunnel installation . . . . .	11-22f	11-36	Cargo rack disassembly . . . . .	12-2b	12-2
Tunnel removal . . . . .	11-22a	11-36	Inspection . . . . .	12-2d	12-2
Cap, air intake tube and, replacement:			Troop seat assembly . . . . .	12-2e	12-2
Installation . . . . .	3-13b	3-20	Troop seat disassembly . . . . .	12-2c	12-2
Removal . . . . .	3-13a	3-20	Troop seat installation . . . . .	12-2g	12-2
Cargo body dropside replacement (M35A2C):			Troop seat removal . . . . .	12-2a	12-2
Installation . . . . .	12-8b	12-12	Cargo bodies tailgate maintenance:		
Removal . . . . .	12-8a	12-12	Cleaning and inspection . . . . .	12-10a	12-15
Cargo body front rack maintenance (M35A2C):			Repair . . . . .	12-10b	12-15
Inspection . . . . .	12-7b	12-10	Cargo body tailgate replacement (M35A2, M36A2):		
Installation . . . . .	12-7c	12-10	Installation . . . . .	12-3b	12-4
Removal . . . . .	12-7a	12-10	Removal . . . . .	12-3a	12-4
Cargo body front rack maintenance (M36A2):			Cargo body tailgate replacement (M35A2C):		
Assembly . . . . .	12-9c	12-14	Installation . . . . .	12-4b	12-5
Disassembly . . . . .	12-9a	12-14	Removal . . . . .	12-4a	12-5
Inspection . . . . .	12-9b	12-14	Cargo body upper and lower rear splash guard replacement (M35A2C):		
Cargo body personnel heater control box replacement:			Lower splash guard installation. . . . .	12-5d	12-6
Installation . . . . .	14-21b	14-31	Lower splash guard removal . . . . .	12-5a	12-6
Removal . . . . .	14-21a	14-31	Upper splash guard installation.. . . .	12-5c	12-6
Cargo body personnel heater diverter and duct replacement:			Upper splash guard removal . . . . .	12-5b	12-6
Installation . . . . .	14-23b	14-34	Carriage cross chain maintenance (M764):		
Removal . . . . .	14-23a	14-34	Adjustment . . . . .	13-12d	13-20
Cargo body personnel heater fuel filter replacement:			Inspection . . . . .	13-12b	13-20
Installation . . . . .	14-20b	14-30	Installation . . . . .	13-12c	13-20
Removal . . . . .	14-20a	14-30	Removal . . . . .	13-12a	13-20
Cargo body personnel heater fuel line replacement:			Carrier, dump body spare tire, replacement:		
Installation . . . . .	14-22b	14-32	Installation . . . . .	12-18b	12-27
Removal . . . . .	14-22a	14-32	Removal . . . . .	12-18a	12-26
Cargo body personnel heater fuel pump replacement:			Carrier, spare tire, maintenance (all except M342A2):		
Installation . . . . .	14-19b	14-29	Assembly. . . . .	10-7d	10-9
Removal . . . . .	14-19a	14-29	Disassembly . . . . .	10-7b	10-8
Cargo body personnel heater mounting bracket replacement:			Inspection . . . . .	10-7c	10-8
Installation . . . . .	14-18b	14-28	Installation . . . . .	10-7e	10-9
Removal . . . . .	14-18a	14-28	Removal . . . . .	10-7a	10-8
Cargo body personnel heater replacement:			Center mounted, troop seat, kit replacement:		
Installation . . . . .	14-17b	14-26	Installation . . . . .	14-54b	14-93
Removal . . . . .	14-17a	14-26	Removal . . . . .	14-54a	14-92
			Characteristics, capabilities, and features, equipment . . . . .	1-10	1-4
			Charging system:		
			Electrical troubleshooting (100 amp) . . . . .		2-95

INDEX (Contd)

	Para	Page		Para	Page
Electrical troubleshooting (60 amp) . . . . .		2-89	Cluster, instrument, replacement:		
Electrical troubleshooting (25 amp) . . . . .		2-98	Assembly . . . . .	4-10c	4-18
Check and adjustment, toe-in:			Disassembly . . . . .	4-10b	4-18
Toe-in adjustment . . . . .	9-7b	9-13	Installation . . . . .	4-10d	4-18
Toe-in check . . . . .	9-7a	9-12	Removal . . . . .	4-10a	4-16
Check rod, cab door, replacement:			Clutch control linkage maintenance:		
Installation . . . . .	11-8b	11-12	Adjustment . . . . .	3-10c	3-18
Removal . . . . .	11-8a	11-12	Installation . . . . .	3-10b	3-16
Chemical agent alarm mounting kit replacement:			Removal . . . . .	3-10a	3-14
Installation . . . . .	14-46b	14-80	Clutch system maintenance index..	3-9	3-14
Removal . . . . .	14-46a	14-78	Collapsible cable reel disassembly:		
CI engine GO-chain index, TK mode, table 2-8:			Assembly . . . . .	12-94b	12-156
Vehicle testing . . . . .	2-21	2-159	Disassembly . . . . .	12-94a	12-156
CI engine NO-GO chain index, TK mode, table 2-9:			Common tools and equipment . . . . .	2-1	2-1
Vehicle testing . . . . .	2-21	2-159	Companion seat maintenance:		
Circuit breaker replacement:			Companion seat backrest installation . . . . .	11-26h	11-43
Installation . . . . .	4-33b	4-51	Companion seat backrest removal . . . . .	11-26a	11-42
Removal . . . . .	4-33a	4-51	Companion seat cushion installation . . . . .	11-26g	11-43
Circuit breaker, 24 V, replacement:			Companion seat cushion removal	11-26b	11-42
Installation . . . . .	12-65b	12-105	Companion seat installation . . . . .	11-26f	11-43
Removal . . . . .	12-65a	12-105	Companion seat removal . . . . .	11-26c	11-42
Clamp and gin pole replacement:			Frame assembly, . . . . .	11-26e	11-42
Installation . . . . .	12-100b	12-166	Frame disassembly . . . . .	11-26d	11-42
Removal . . . . .	12-100a	12-166	Compartment door, rear, maintenance:		
Clamps, battery cables, and replacement:			Cleaning and inspection . . . . .	12-44b	12-66
Battery clamps installation . . . . .	4-48g	4-74	Installation . . . . .	12-44d	12-66
Battery clamps removal . . . . .	4-48f	4-74	Removal . . . . .	12-44a	12-66
Battery-to-battery cable installation . . . . .	4-48i	4-74	Repair . . . . .	12-44c	12-66
Battery-to-battery cable removal . . . . .	4-48d	4-74	Compartment, glove, replacement:		
Ground cable connection . . . . .	4-48b	4-73	Installation . . . . .	11-18b	11-28
Ground cable disconnection . . . . .	4-48a	4-73	Removal . . . . .	11-18a	11-28
Ground cable installation . . . . .	4-48j	4-74	Compressed air and brake system operation:		
Ground cable removal . . . . .	4-48c	4-74	Brake system operation . . . . .	1-21b	1-62
Positive cable installation . . . . .	4-48h	4-74	Compressed air system operation	1-21a	1-60
Positive cable removal . . . . .	4-48e	4-74	Compressed air and brake system troubleshooting:		
Cleaner assembly, air, maintenance:			General . . . . .	2-13	2-52
Inspection . . . . .	3-15b	3-24	Air-operated accessories . . . . .	2-13	2-71
Installation . . . . .	3-15c	3-24	Compressed air . . . . .	2-13	2-62
Removal . . . . .	3-15a	3-24	Parking brake . . . . .	2-13	2-54
Clearance lamps, side marker and, replacement:			Service brakes . . . . .	2-13	2-56
Installation . . . . .	4-45b	4-69	Compressed air system mainte- nance:		
Removal . . . . .	4-45a	4-69	General . . . . .	8-17	8-45
			Index . . . . .	8-18	8-45
			Compressor, air, servicing:		
			Assembly . . . . .	8-27d	8-66

INDEX (Contd)

	Para	Page		Para	Page
Cleaning .....	8-27c	8-66	Control switch, hot water personnel heater, replacement:		
Disassembly .....	8-27b	8-66	Installation .....	4-34b	4-52
Installation .....	8-27e	8-67	Removal .....	4-34a	4-52
Removal .....	8-27a	8-66	Control systems operation:		
Connector, wiring harness, repair:			Accelerator controls system		
Connector assembly repair .....	4-51d	4-80	operation .....	1-18c	1-41
Female cable connector repair...	4-51c	4-80	Clutch control system operation..	1-18f	1-44
Male cable connector repair .....	4-51b	4-80	Manifold heater system		
Receptacle assembly repair .....	4-51e	4-81	operation .....	1-18b	1-40
Terminal-type cable connector repair .....	4-51a	4-79	Parking brake system operation.	1-18d	1-42
Construction body, pipeline maintenance index .....	12-99	12-165	Starting system operation .....	1-18a	1-38
Control box, personnel heater, replacement:			Steering system operation .....	1-18e	1-43
Installation .....	14-3b	14-3	Transfer case control system		
Removal .....	14-3a	14-3	operation .....	1-18g	1-45
Control cable, hand throttle, maintenance:			Control valve replacement:		
Adjustment .....	3-35c	3-80	Installation .....	14-39b	14-62
Installation .....	3-35b	3-80	Removal .....	14-39a	14-62
Removal .....	3-35a	3-78	Control valve, windshield wiper motor, replacement:		
Control cables, personnel heater, replacement:			Installation .....	8-19b	8-46
Adjustment .....	11-41c	11-78	Removal .....	8-19a	8-46
Installation .....	11-41b	11-78	Converter receptacle replacement:		
Removal .....	11-41a	11-78	115V converter receptacle		
Control cable, speed maintenance:			installation .....	12-72d	12-118
Adjustment .....	12-54d	12-89	115V converter receptacle		
Inspection .....	12-54b	12-88	removal .....	12-72c	12-118
Installation .....	12-54c	12-88	24V converter receptacle		
Removal .....	12-54a	12-88	installation .....	12-72b	12-118
Control lever linkage, rear winch, maintenance (M764):			24V converter receptacle		
Installation .....	13-8b	13-14	removal .....	12-72a	12-118
Removal .....	13-8a	13-14	Converter replacement:		
Control levers, discharge valve, maintenance (M49A2C):			Installation .....	12-69b	12-112
Assembly .....	12-21d	12-35	Removal .....	12-69a	12-112
Cleaning and inspection .....	12-21c	12-34	Converter selector switch		
Disassembly .....	12-21b	12-33	replacement:		
Installation .....	12-21e	12-36	Installation .....	12-67b	12-108
Removal .....	12-21a	12-32	Removal .....	12-67a	12-108
Control linkage, clutch, maintenance:			Coolant heater, engine, replacement:		
Adjustment .....	3-10c	3-18	Installation .....	14-8b	14-10
Installation .....	3-10b	3-16	Removal .....	14-8a	14-10
Removal .....	3-10a	3-14	Coolant heater harness, engine, replacement:		
Control linkage, hydraulic hoist, maintenance (M342A2):			Installation .....	14-9b	14-12
Inspection .....	13-22b	13-38	Removal .....	14-9a	14-12
Installation .....	13-22c	13-38	Cooling system servicing:		
Removal .....	13-22a	13-38	Cleaning and flushing system ...	3-41b	3-94
			Draining system .....	3-41a	3-94
			Filling system .....	3-41c	3-94

INDEX (Contd)

	Para	Page		Para	Page
Coupling half, quick disconnect, maintenance:			Cylinder, air-hydraulic, replacement:		
Installation . . . . .	8-30c	8-74	Installation . . . . .	8-11b	8-31
Leak test . . . . .	8-30a	8-74	Removal . . . . .	8-11a	8-30
Removal . . . . .	8-30b	8-74	<b>D</b>		
Couplings and airbrake cutoff valves replacement (M764):			Data plate replacement:		
Installation . . . . .	8-32b	8-80	Installation . . . . .	11-37b	11-74
Removal . . . . .	8-32a	8-80	Removal . . . . .	11-37a	11-74
Couplings and airbrake cutoff valves replacement (M275A2, M342A2):			Decontamination mounting kit replacement:		
Installation . . . . .	8-33b	8-80	Installation . . . . .	14-45b	14-76
Removal . . . . .	8-33a	8-80	Removal . . . . .	14-45a	14-76
Couplings, airbrake cutoff valves and, replacement:			Deep water fording kit maintenance index. . . . .	14-37	14-60
Installation . . . . .	8-31b	8-76	Defroster hoses, personnel heater, replacement:		
Removal . . . . .	8-31a	8-76	Installation . . . . .	11-43b	11-85
Cover and drive chain, leveling worm, maintenance:			Removal . . . . .	11-43a	11-85
Horizontal drive chain adjustment . . . . .	12-87b	12-140	Delivery pump draincock replacement:		
Horizontal drive chain cover installation . . . . .	12-87c	12-140	Installation . . . . .	12-36b	12-56
Horizontal drive chain cover removal . . . . .	12-87a	12-140	Removal . . . . .	12-36a	12-56
Vertical drive chain adjustment. . . . .	12-87e	12-142	Delivery pump front propeller shaft maintenance (M49A2C, M50A3):		
Vertical drive chain cover installation . . . . .	12-876f	12-142	Inspection . . . . .	12-51b	12-82
Vertical drive chain cover removal . . . . .	12-87d	12-142	Installation . . . . .	12-51c	12-82
Cover, manhole, maintenance (M49A2C):			Removal . . . . .	12-51a	12-82
Assembly . . . . .	12-23d	12-40	Delivery pump front propeller shaft maintenance (M50A2):		
Disassembly . . . . .	12-23b	12-40	Inspection . . . . .	12-50b	12-81
Inspection . . . . .	12-23c	12-40	Installation . . . . .	12-50c	12-81
Installation . . . . .	12-23e	12-41	Removal . . . . .	12-50a	12-81
Removal . . . . .	12-23a	12-40	Delivery pump inlet tube replacement (M49A2C):		
Crankcase breather tube adapter replacement:			Installation . . . . .	12-33b	12-52
Installation . . . . .	3-8b	3-13	Removal . . . . .	12-33a	12-52
Removal . . . . .	3-8a	3-13	Delivery pump outlet tube replacement (M49A2C):		
Crankcase breather tube maintenance:			Installation . . . . .	12-32b	12-51
Cleaning and inspection . . . . .	3-6b	3-8	Removal . . . . .	12-32a	12-51
Installation . . . . .	3-6c	3-8	Delivery pump rear propeller shaft replacement (M49A2C, M50A3):		
Removal . . . . .	3-6a	3-8	Installation . . . . .	12-53b	12-86
Cross chain, carnage, maintenance (M764):			Removal . . . . .	12-53a	12-86
Adjustment . . . . .	13-12d	13-20	Delivery pump rear propeller shaft maintenance (M50A2):		
Inspection . . . . .	13-12b	13-20	Inspection . . . . .	12-52b	12-84
Installation . . . . .	13-12c	13-20	Installation . . . . .	12-52c	12-84
Removal . . . . .	13-12a	13-20	Removal . . . . .	12-52a	12-84
			Delivery pump replacement:		
			Installation . . . . .	12-35b	12-54
			Removal . . . . .	12-35a	12-54



INDEX (Contd)

	Para	Page		Para	Page
Delivery pump strainer replacement:			Discharge valve		
Installation . . . . .	12-39b	12-59	replacement (M49A2C):		
Removal . . . . .	12-39a	12-59	Installation . . . . .	12-20b	12-31
Description and operation, STE/ICE:			Removal . . . . .	12-20a	12-30
Table 2-5, status readouts . . . . .	2-20	2-153	Diverter, personnel heater,		
Table 2-6, prompting messages..	2-20	2-153	replacement:		
Table 2-7, error readouts . . . . .	2-20	2-154	Installation . . . . .	11-39b	11-76
Destruction of Army materiel to			Removal . . . . .	11-39a	11-76
prevent enemy use . . . . .	1-3	1-1	Dome lamp and housing		
Differences between models,			replacement:		
table 1-1 . . . . .	1-14	1-30	Installation . . . . .	12-61b	12-98
Dimmer switch, headlight,			Removal . . . . .	12-61a	12-98
replacement:			Door catch, cab, replacement:		
Installation . . . . .	4-28b	4-44	Installation . . . . .	11-9b	11-13
Removal . . . . .	4-28a	4-44	Removal . . . . .	11-9a	11-13
Dipstick tube, oil, replacement:			Door check replacement:		
Installation . . . . .	3-5b	3-6	Installation . . . . .	12-77b	12-125
Removal . . . . .	3-5a	3-6	Removal . . . . .	12-77a	12-125
Discharge tube and valve, water			Door glass and weatherseal, cab,		
tank, replacement (M50A2):			replacement:		
Discharge tube installation . . . . .	12-45d	12-68	Cab door glass adjustment . . . . .	11-5c	11-6
Discharge tube removal . . . . .	12-45a	12-68	Installation . . . . .	11-5b	11-6
Discharge valve installation . . . . .	12-45c	12-68	Removal . . . . .	11-5a	11-6
Discharge valve removal . . . . .	12-45b	12-68	Door holder assembly and bracket		
Discharge tube and valve, water			replacement:		
tank, replacement (M50A3):			Installation . . . . .	12-76b	12-124
Discharge tube cover installation	12-46f	12-71	Removal . . . . .	12-76a	12-124
Discharge tube cover removal . . . . .	12-46a	12-70	Door seals, van, maintenance:		
Discharge tube installation . . . . .	12-46e	12-70	Cleaning . . . . .	12-63b	12-101
Discharge tube removal . . . . .	12-46b	12-70	Installation . . . . .	12-63c	12-101
Discharge valves installation . . . . .	12-46d	12-70	Removal . . . . .	12-63a	12-101
Discharge valves removal . . . . .	12-46c	12-70	Door, van, repair:		
Discharge tubes, front and rear			Cleaning and inspection . . . . .	12-64c	12-102
fuel tank, replacement (M49A2C):			Left van door assembly . . . . .	12-64e	12-104
Installation . . . . .	12-22b	12-38	Left van door disassembly . . . . .	12-64a	12-102
Removal . . . . .	1 2-22a	12-37	Right van door assembly . . . . .	12-64d	12-104
Discharge valve control levers			Right van door disassembly . . . . .	12-64b	12-102
maintenance (M49A2C):			Door, van, replacement:		
Assembly . . . . .	12-21d	12-35	Installation . . . . .	12-62b	12-100
Cleaning and inspection . . . . .	12-21c	12-34	Removal . . . . .	12-62a	12-100
Disassembly . . . . .	12-21b	12-33	Dovetail wedge, cab door,		
Installation . . . . .	12-21e	12-36	replacement:		
Removal . . . . .	12-21a	12-32	Installation . . . . .	11-3b	11-3
Discharge valve control levers,			Removal . . . . .	11-3a	11-3
water tank, maintenance			Drag brake, front winch, test		
(M50A2, M50A3):			and adjustment:		
Adjustment . . . . .	12-47f	12-76	Adjustment . . . . .	13-2b	13-2
Assembly . . . . .	12-47d	12-74	Testing . . . . .	13-2a	13-2
Cleaning and inspection . . . . .	12-47c	12-74	Drag link replacement:		
Disassembly . . . . .	12-47b	12-73	Installation . . . . .	9-11b	9-18
Installation . . . . .	12-47e	12-76	Removal . . . . .	9-11a	9-18
Removal . . . . .	12-47a	12-72			

INDEX (Contd)

	Para	Page		Para	Page
Draincock, delivery pump, replacement:			Drum clutch lever and guide plate, rear winch, replacement (M756A2):		
Installation .....	12-36b	12-56	Installation .....	13-9b	13-16
Removal .....	12-36a	12-56	Removal .....	13-9a	13-16
Drivebelt, air compressor, replacement:			Drum lock, winch, replacement (M756A2):		
Adjustment .....	8-28c	8-68	Inspection .....	13-7b	13-13
Installation .....	8-28b	8-68	Installation .....	13-7c	13-13
Removal .....	8-28a	8-68	Removal .....	13-7a	13-13
Drivechain, horizontal leveling worm, replacement:			Duct, primary heater and, replacement:		
Installation .....	12-85b	12-136	Duct installation .....	14-32c	14-50
Removal .....	12-85a	12-136	Duct removal .....	14-32b	14-50
Drivechain, rear winch, maintenance (M756A2):			Heater installation .....	14-32d	14-51
Adjustment .....	13-11c	13-18	Heater removal .....	14-32a	14-48
Installation .....	13-11b	13-18	Duct, secondary heater and, replacement:		
Removal .....	13-11a	13-18	Duct installation .....	14-36c	14-58
Drivechain, first reduction, maintenance (M764):			Duct removal .....	14-36b	14-58
Adjustment .....	13-14c	13-24	Heater, exhaust tube and guard installation .....	14-36d	14-59
Installation .....	13-14b	13-24	Heater, exhaust tube and guard removal .....	14-36a	14-56
Removal .....	13-14a	13-24	Dump body front splash guard replacement:		
Drivechain, second reduction, maintenance (M764):			Installation .....	12-15b	12-20
Adjustment .....	13-15c	13-26	Removal .....	12-15a	12-20
Installation .....	13-15b	13-26	Dump body maintenance index . . .	12-11	12-16
Removal .....	13-15a	13-26	Dump body rear splash guard replacement:		
Drive core, tachometer driveshaft and, maintenance:			Installation .....	12-17b	12-24
Inspection .....	4-14b	4-26	Removal .....	12-17a	12-24
Installation .....	4-14c	4-26	Dump body spare tire carrier replacement:		
Removal .....	4-14a	4-26	Installation .....	12-18b	12-27
Driver's seat cushion, backrest, frame, and seat adjuster replacement:			Removal .....	12-18a	12-26
Driver's seat adjuster installation	11-29e	11-50	Dump body tailgate repair:		
Driver's seat adjuster removal . . .	11-29d	11-50	Cleaning .....	12-13a	12-18
Driver's seat backrest installation .....	11-29g	11-50	Inspection and repair .....	12-13b	12-18
Driver's seat backrest removal...	11-29b	11-50			
Driver's seat cushion installation	11-29h	11-51	<b>E</b>		
Driver's seat cushion removal . . .	11-29a	11-50	Earth boring machine propeller shaft maintenance:		
Driver's seat frame installation..	11-29f	11-50	Assembly .....	12-89c	12-144
Driver's seat frame removal . . . . .	11-29c	11-50	Disassembly .....	12-89b	12-144
Driver's seat replacement			Installation .....	12-89d	12-144
Installation .....	11-28b	11-49	Removal .....	12-89a	12-144
Removal .....	11-28a	11-49	Earth boring machine seat and and seat backrest cushion replacement:		
Dropside, cargo body, replacement (M35A2C):			Installation .....	12-93b	12-155
Installation .....	12-8b	12-12	Removal .....	12-93a	12-155
Removal .....	12-8a	12-12			

## INDEX (Contd)

	Para	Page		Para	Page
Earth boring machine seat frame replacement:			Equipment, common tools and . . . . .	2-1	2-1
Installation . . . . .	12-92b	12-154	Equipment characteristics, capabilities, and features . . . . .	1-10	1-4
Removal . . . . .	12-92a	12-154	Equipment data, table 1-2 . . . . .	1-15	1-31
Electrical systems operation:			Evaporator, alcohol, replacement:		
Battery system operation . . . . .	1-20a	1-56	Installation . . . . .	14-15b	14-22
Gage and warning system operation . . . . .	1-20e	1-59	Removal . . . . .	14-15a	14-22
Generating system operation . . . . .	1-20c	1-58	Exhaust blower duct assembly replacement:		
Heating system operation . . . . .	1-20d	1-58	Installation . . . . .	12-78b	12-126
Starting system operation . . . . .	1-20b	1-57	Removal . . . . .	12-78a	12-126
Electrical systems troubleshooting:			Exhaust blower motor and bracket replacement:		
General . . . . .	2-14	2-74	Installation . . . . .	12-60b	12-97
Electrical test equipment . . . . .	2-15	2-75	Removal . . . . .	12-60a	12-97
Electrical troubleshooting, table 2-4 . . . . .		2-77	Exhaust blower switch replacement:		
Element, air cleaner and cap, replacement:			Installation . . . . .	12-68b	12-110
Cap installation . . . . .	3-14d	3-23	Removal . . . . .	12-68a	12-110
Cap removal . . . . .	3-14a	3-22	Exhaust system replacement (M50A2 and M50A3):		
Element installation . . . . .	3-14c	3-23	Installation . . . . .	3-38b	3-88
Element removal . . . . .	3-14b	3-22	Removal . . . . .	3-38a	3-86
Engine coolant heater replacement:			Exhaust system replacement:		
Installation . . . . .	14-8b	14-10	Installation . . . . .	3-37b	3-84
Removal . . . . .	14-8a	14-10	Removal . . . . .	3-37a	3-82
Engine front mount pad replacement:			Exhaust tube, oil pan shroud and, replacement:		
Front mount pad installation . . . . .	3-2d	3-2	Installation . . . . .	14-7b	14-9
Front mount pad removal . . . . .	3-2a	3-2	Removal . . . . .	14-7a	14-9
Support plate installation . . . . .	3-2c	3-2	Exhaust tube, primary and secondary heater, replacement:		
Support plate removal . . . . .	3-2b	3-2	Installation . . . . .	14-30b	14-46
Engine oil filter and body maintenance:			Removal . . . . .	14-30a	14-46
Body assembly . . . . .	3-7e	3-12	Exhaust tube replacement:		
Body disassembly . . . . .	3-7c	3-11	Installation . . . . .	14-6b	14-8
Cleaning and inspection . . . . .	3-7d	3-12	Removal . . . . .	14-6a	14-8
Draining oil . . . . .	3-7a	3-10	Expendable/durable supplies and materials list, appendix C:		
Oil filter installation . . . . .	3-7f	3-12	Scope . . . . .	C-1	C-1
Oil filter removal . . . . .	3-7b	3-10	Explanation of columns . . . . .	C-2	C-1
Engine rear mount pad replacement:			Extension, front winch, replacement:		
Installation . . . . .	3-3b	3-4	Installation . . . . .	10-10b	10-14
Removal . . . . .	3-3a	3-4	Removal . . . . .	10-10a	10-14
Engine stop control cable maintenance:			External components, major, location and description . . . . .	1-11	1-10
Adjustment . . . . .	3-34c	3-76			
Installation . . . . .	3-34b	3-76	<b>F</b>		
Removal . . . . .	3-34a	3-76	Fan replacement:		
Engine temperature sending unit replacement:			Installation . . . . .	3-40b	3-92
Installation . . . . .	4-24b	4-39	Removal . . . . .	3-40a	3-92
Removal . . . . .	4-24a	4-39			

INDEX (Contd)

	Para	Page		Para	Page
Fasteners, hood, replacement:			First reduction drivechain		
Hood holddown fastener and			maintenance (M764):		
bracket installation . . . . .	11-13f	11-21	Adjustment . . . . .	13-14c	13-24
Hood holddown fastener and			Installation . . . . .	13-14b	13-24
bracket removal . . . . .	11-13a	11-20	Removal . . . . .	13-14a	13-24
Hood support hook installation..	11-13d	11-20	Fixed seatbelt kit replacement:		
Hood support hook removal . . . .	11-13c	11-20	Installation companion		
Safety latch installation . . . . .	11-13e	11-21	seatbelts . . . . .	14-55d	14-95
Safety latch removal . . . . .	11-13b	11-20	Installation driver's seatbelts . . .	14-55b	14-94
Fifth wheel replacement:			Removal companion seatbelts... .	14-55c	14-94
Installation . . . . .	12-112b	12-181	Removal driver's seatbelts . . . . .	14-55a	14-94
Removal . . . . .	12-112a	12-181	Flasher, turn signal, replacement:		
Filler cover, water tank,			Installation . . . . .	4-20b	4-35
replacement (M50A2):			Removal . . . . .	4-20a	4-35
Installation . . . . .	12-42b	12-64	Flexible hydraulic brake line		
Removal . . . . .	12-42a	12-64	modification:		
Filler cover, water tank,			Installation . . . . .	8-16c	8-44
replacement (M50A3):			Modification . . . . .	8-16b	8-43
Installation . . . . .	12-43b	12-65	Removal . . . . .	8-16a	8-42
Removal . . . . .	12-43a	12-65	Floating seatbelt kit replacement:		
Filter separator			Installation of companion		
maintenance (M49A2C):			seatbelts . . . . .	14-56d	14-97
Assembly . . . . .	12-41d	12-63	Installation of driver's seatbelts.	14-56b	14-96
Cleaning and inspection . . . . .	12-41c	12-63	Removal of companion seatbelts.	14-56c	14-96
Disassembly . . . . .	12-41b	12-62	Removal of driver's seatbelts . . . .	14-56a	14-96
Installation . . . . .	12-41e	12-63	Floodlamp housing and mount		
Removal . . . . .	12-41a	12-62	maintenance:		
Filter separator-to-sump pipe			Floodlamp housing and mount		
replacement (M49A2C):			assembly . . . . .	4-43c	4-66
Installation . . . . .	12-28b	12-47	Floodlamp housing and mount		
Removal . . . . .	12-28a	12-47	disassembly . . . . .	4-43b	4-66
Filter tube to meter			Floodlamp housing and mount		
replacement (M49A2C):			installation . . . . .	4-43d	4-67
Installation . . . . .	12-30b	12-49	Floodlamp housing and mount		
Removal . . . . .	12-30a	12-49	removal . . . . .	4-43a	4-66
Final, secondary and, fuel filters			Floodlamp replacement:		
testing and maintenance:			Floodlamp installation . . . . .	4-44b	4-68
Bleeding air . . . . .	3-29h	3-58	Floodlamp removal . . . . .	4-44a	4-68
Cleaning and inspection . . . . .	3-29e	3-56	Floodlight bracket replacement:		
Draining . . . . .	3-29b	3-55	Installation . . . . .	12-73b	12-120
Fuel filter head, secondary,			Removal . . . . .	12-73a	12-120
and final fuel filters installation	3-29g	3-58	Front and rear axle breather		
Fuel filter head, secondary, and			maintenance:		
final fuel filters removal . . . . .	3-29c	3-56	Cleaning . . . . .	7-8b	7-21
Fuel filters installation . . . . .	3-29f	3-56	Installation . . . . .	7-8c	7-21
Fuel filters removal . . . . .	3-29d	3-56	Removal . . . . .	7-8a	7-21
Testing fuel pressure . . . . .	3-29a	3-54	Front and rear deck replacement:		
Fire extinguisher mounting kit			Front deck installation . . . . .	12-110c	12-178
replacement:			Front deck removal . . . . .	12-110b	12-178
Installation . . . . .	14-47b	14-82	Rear deck installation . . . . .	12-110d	12-179
Removal . . . . .	14-47a	14-82	Rear deck removal . . . . .	12-110a	12-178
			Front and rear fuel tank discharge		
			tubes replacement (M49A2C):		
			Installation . . . . .	12-22b	12-38
			Removal . . . . .	12-22a	12-37

INDEX (Contd)

	Para	Page		Para	Page
Front and rear splash guard replacement:			Front rack, cargo body maintenance, (M35A2C):		
Front splash guard installation . . . . .	12-102d	12-169	Assembly . . . . .	12-7c	12-10
Front splash guard removal . . . . .	12-102a	12-168	Inspection . . . . .	12-7b	12-10
Rear splash guard installation . . . . .	12-102c	12-168	Removal . . . . .	12-7a	12-10
Rear splash guard removal . . . . .	12-102b	12-168	Front rack, cargo body, maintenance (M36A2):		
Front axle shaft and universal joint maintenance:			Installation . . . . .	12-9c	12-14
Cleaning and inspection . . . . .	7-6b	7-17	Disassembly . . . . .	12-9a	12-14
Installation . . . . .	7-6c	7-18	Inspection . . . . .	12-9b	12-14
Removal . . . . .	7-6a	7-16	Front shackle (w/o winch) replacement:		
Front axle shaft flange maintenance:			Installation . . . . .	10-2b	10-2
Cleaning and inspection . . . . .	7-10b	7-24	Removal . . . . .	10-2a	10-2
Installation . . . . .	7-10c	7-25	Front shackle (w/winch) replacement:		
Removal . . . . .	7-10a	7-24	Installation . . . . .	10-3b	10-3
Front axle oil seal assembly replacement:			Removal . . . . .	10-3a	10-3
Installation . . . . .	7-7b	7-20	Front splash guard, dump body, replacement:		
Removal . . . . .	7-7a	7-20	Installation . . . . .	12-15b	12-20
Front bumper replacement:			Removal . . . . .	12-15a	12-20
Installation . . . . .	10-9b	10-12	Front splash guard replacement (M35A2C, M36A2):		
Removal . . . . .	10-9a	10-12	Installation . . . . .	12-6b	12-8
Front composite lamps, housing, and bracket replacement:			Removal . . . . .	12-6a	12-8
Composite light housing installation . . . . .	4-41c	4-62	Front splash guard, tank bodies, replacement:		
Composite light housing removal . . . . .	4-41b	4-62	Installation . . . . .	12-55b	12-90
Composite lamps installation . . . . .	4-41d	4-62	Removal . . . . .	12-55a	12-90
Composite lamps removal . . . . .	4-41a	4-62	Front splash guard, van bodies, replacement:		
Front fender's maintenance:			Installation . . . . .	12-70b	12-113
Inspection and repair . . . . .	11-30b	11-54	Removal . . . . .	12-70a	12-113
Installation . . . . .	11-30c	11-54	Front spring bumper replacement:		
Removal . . . . .	11-30a	11-52	Installation . . . . .	7-15b	7-34
Front hub and drum maintenance:			Removal . . . . .	7-15a	7-34
Cleaning and inspection . . . . .	9-3b	9-6	Front spring maintenance:		
Installation . . . . .	9-3d	9-7	Assembly . . . . .	7-16c	7-38
Lubrication . . . . .	9-3c	9-7	Cleaning and inspection . . . . .	7-16b	7-38
Removal . . . . .	9-3a	9-6	Disassembly . . . . .	7-16a	7-36
Front mount pad, engine, replacement:			Front spring replacement:		
Front mount pad installation . . . . .	3-2d	3-2	Installation . . . . .	7-13b	7-30
Front mount pad removal . . . . .	3-2a	3-2	Removal . . . . .	7-13a	7-28
Support plate installation . . . . .	3-2c	3-2	Front spring shackle replacement:		
Support plate removal . . . . .	3-2b	3-2	Installation . . . . .	7-14b	7-32
Front propeller shaft, delivery pump, replacement:			Removal . . . . .	7-14a	7-32
(M49A2C, M50A3):			Front-wheel drive lock-in switch indicator and air pressure switch replacement:		
Inspection . . . . .	12-51b	12-82	Indicator lamp installation . . . . .	4-36b	4-54
Installation . . . . .	12-51c	12-82	Indicator lamp removal . . . . .	4-36a	4-54
Removal . . . . .	12-51a	12-82			
Front propeller shaft, delivery pump, maintenance (M50A2):					
Inspection . . . . .	12-50b	12-81			
Installation . . . . .	12-50c	12-81			
Removal . . . . .	12-50a	12-81			

INDEX (Contd)

	Para	Page		Para	Page
Front-wheel drive lock-in switch maintenance:			Fuel level sending unit replacement:		
Air valve and bracket installation . . . . .	6-4f	6-18	Installation . . . . .	4-26b	4-41
Air valve and bracket removal . . . . .	6-4a	6-12	Removal . . . . .	4-26a	4-41
Cleaning and inspection . . . . .	6-4c	6-15	Fuel line adapter replacement:		
Line installation . . . . .	6-4e	6-16	Installation . . . . .	12-81b	12-130
Line removal . . . . .	6-4b	6-14	Removal . . . . .	12-81a	12-130
Repair . . . . .	6-4d	6-16	Fuel lines, primary heater, replacement:		
Front winch cable replacement:			Filter-to-pump inlet tube installation . . . . .	14-28d	14-40
Installation . . . . .	13-3b	13-3	Filter-to-pump inlet tube removal . . . . .	14-28c	14-40
Removal . . . . .	13-3a	13-3	Fuel heater-to-adapter tube installation . . . . .	14-28h	14-43
Front winch drag brake test and adjustment:			Fuel heater-to-adapter tube removal . . . . .	14-28g	14-43
Adjustment . . . . .	13-2b	13-2	Fuel tank shutoff-to-filter hose installation . . . . .	14-28b	14-40
Testing . . . . .	13-2a	13-2	Fuel tank shutoff-to-filter hose removal . . . . .	14-28a	14-40
Front winch extension replacement:			Pump outlet-to-adapter tube installation . . . . .	14-28f	14-42
Installation . . . . .	10-10b	10-14	Pump outlet-to-adapter tube removal . . . . .	14-28e	14-42
Removal . . . . .	10-10a	10-14	Fuel lines, secondary heater, replacement:		
Front winch propeller shaft replacement:			Installation . . . . .	14-35b	14-55
Inspection . . . . .	13-6b	13-12	Removal . . . . .	14-35a	14-55
Installation . . . . .	13-6c	13-12	Fuel pressure switch replacement:		
Removal . . . . .	13-6a	13-12	Installation . . . . .	4-37b	4-56
Front winch replacement:			Removal . . . . .	4-37a	4-56
Installation . . . . .	13-5b	13-8	Fuel pump cover, primary heater, replacement:		
Removal . . . . .	13-5a	13-8	Installation . . . . .	14-26b	14-38
Fuel and water tank nozzle holder replacement:			Removal . . . . .	14-26a	14-38
Installation . . . . .	12-25b	12-44	Fuel pump (in-tank) fuse replacement:		
Removal . . . . .	12-25a	12-44	Installation . . . . .	3-23b	3-33
Fuel burning personnel heater replacement:			Removal . . . . .	3-33a	3-33
Installation . . . . .	14-2b	14-2	Fuel pump (in-tank) maintenance:		
Removal . . . . .	14-2a	14-2	Assembly . . . . .	3-26e	3-46
Fuel filter, personnel heater, replacement:			Cleaning and inspection . . . . .	3-26d	3-46
Installation . . . . .	14-5b	14-6	Disassembly . . . . .	3-26c	3-44
Removal . . . . .	14-5a	14-6	Installation . . . . .	3-26f	3-48
Fuel filter, primary heater, replacement:			Removal . . . . .	3-26b	3-43
Installation . . . . .	14-27b	14-39	Testing fuel pump pressure . . . . .	3-26a	3-42
Removal . . . . .	14-27a	14-39	Fuel pump, personnel heater, replacement:		
Fuel filter, primary, maintenance:			Installation . . . . .	14-4b	14-4
Cleaning and inspection . . . . .	3-28d	3-52	Removal . . . . .	14-4a	14-4
Draining . . . . .	3-28a	3-50	Fuel pump, primary heater, replacement:		
Filter housing installation . . . . .	3-28f	3-52	Installation . . . . .	14-25b	14-37
Filter housing removal . . . . .	3-28b	3-50	Removal . . . . .	14-25a	14-37
Filter installation . . . . .	3-28e	3-52			
Filter removal . . . . .	3-28c	3-52			
Fuel hose and nozzle replacement (M49A2C):					
Installation . . . . .	12-24b	12-44			
Removal . . . . .	12-24a	12-44			

INDEX (Contd)

	Para	Page		Para	Page
Fuel return tees and tubes replacement:			Gearshift lever, transmission, replacement:		
Installation . . . . .	3-27b	3-49	Installation . . . . .	5-4b	5-4
Removal . . . . .	3-27a	3-49	Removal . . . . .	5-4a	5-4
Fuel shutoff and coupling, primary heater, replacement:			Gearshift, transmission, and transfer case lever cover replacement:		
Installation . . . . .	14-29b	14-44	Installation . . . . .	14-12b	14-17
Removal . . . . .	14-29a	14-44	Removal . . . . .	14-12a	14-17
Fuel system maintenance:			General information:		
General . . . . .	3-20	3-31	Destruction of Army materiel to prevent enemy use . . . . .	1-3	1-1
Fuel tank discharge tubes, front and rear, replacement (M49A2C):			Equipment improvement report and maintenance digest (EIR MD) . . . . .	1-6	1-2
Installation . . . . .	12-22b	12-38	Maintenance forms, records, and reports . . . . .	1-2	1-1
Removal . . . . .	12-22a	12-37	Preparation for storage or shipment . . . . .	1-4	1-1
Fuel tank filler cap and sleeve replacement:			Reporting quality deficiencies, ideas, and equipment improvement recommendations . . . . .	1-5	1-1
Installation . . . . .	3-22b	3-32	Scope . . . . .	1-1	<b>1-1</b>
Removal . . . . .	3-22a	3-32	Warranty information . . . . .	1-7	<b>1-2</b>
Fuel tank replacement (M275A2):			General inspection and servicing instructions . . . . .	2-5	2-1
Installation . . . . .	3-25b	3-40	General preparation of truck for shipment and limited storage:		
Removal . . . . .	3-25a	3-38	Cleaning . . . . .	15-2	15-1
Fuel tank replacement:			Inspection in limited storage . . . . .	15-11	15-3
Installation . . . . .	3-24b	3-36	Limited storage instructions . . . . .	15-10	15-3
Removal . . . . .	3-24a	3-34	Loading and movement . . . . .	15-8	15-2
Fuse, safety switch, replacement:			Lubrication . . . . .	15-3	15-1
Installation . . . . .	12-59b	12-96	Packaging . . . . .	15-5	15-2
Removal . . . . .	12-59a	12-96	Packing . . . . .	15-6	15-2
<b>G</b>			Preservation . . . . .	15-4	15-2
Gage, separator element test valve, and lines replacement (M49A2C):			Removal from limited storage . . . . .	15-12	15-3
Installation . . . . .	12-40b	12-60	Scope . . . . .	15-1	15-1
Removal . . . . .	12-40a	12-60	Shipment of army documents . . . . .	15-7	15-2
Gage, oil pressure, battery and generator, fuel, and engine temperature, replacement:			General service and inspection procedures . . . . .	2-10	2-3
Installation . . . . .	4-12b	4-22	Gin pole and clamp replacement:		
Removal . . . . .	4-12a	4-22	Installation . . . . .	12-100b	12-166
Gallon meter replacement (M49A2C):			Removal . . . . .	12-100a	12-166
Installation . . . . .	12-31b	12-50	Glass, windshield arm, handle and, replacement:		
Removal . . . . .	12-31a	12-50	Arm installation . . . . .	11-21f	11-35
Gate valve replacement:			Arm removal . . . . .	11-21a	11-34
Installation . . . . .	12-38b	12-58	Glass installation . . . . .	11-21e	11-35
Removal . . . . .	12-38a	12-58	Glass removal . . . . .	11-21b	11-34
Gear, steering, adjustment:			Handle installation . . . . .	11-21d	11-34
Adjustment . . . . .	9-9	9-15	Handle removal . . . . .	11-21c	11-34
Gearshift lever knob and boot, transmission, replacement:			Globe valve replacement (M49A2C):		
Installation . . . . .	5-3b	5-3	Installation . . . . .	12-27b	12-46
Removal . . . . .	5-3a	5-3	Removal . . . . .	12-27a	12-46

INDEX (Contd)

	Para	Page		Para	Page
Glove compartment replacement:			Headlight guard, brush guard,		
Installation . . . . .	11-18b	11-28	and stone shield replacement:		
Removal . . . . .	11-18a	11-28	Brush guard installation . . . . .	10-8e	10-11
Governor, air compressor,			Brush guard removal . . . . .	10-8b	10-10
maintenance:			Headlight guard installation . . . . .	10-8d	10-11
Check and adjustment . . . . .	8-29c	8-72	Headlight guard removal . . . . .	10-8c	10-10
Installation . . . . .	8-29b	8-70	Stone shield installation . . . . .	10-8f	10-11
Removal . . . . .	8-29a	8-70	Stone shield removal . . . . .	10-8a	10-10
<b>H</b>			Headlight high beam indicator		
Hand control valve, airbrake,			and lamp replacement:		
replacement:			Installation . . . . .	4-17b	4-32
Installation . . . . .	8-21b	8-48	Removal . . . . .	4-17a	4-32
Removal . . . . .	8-21a	8-48	Heater air inlet duct, primary,		
Hand throttle control cable			replacement:		
maintenance:			Installation . . . . .	14-31b	14-47
Adjustment . . . . .	3-35c	3-80	Removal . . . . .	14-31a	14-47
Installation . . . . .	3-35b	3-80	Heater, engine coolant,		
Removal . . . . .	3-35a	3-78	replacement:		
Handle, cab door window regulator			Installation . . . . .	14-8b	14-10
and, replacement:			Removal . . . . .	14-8a	14-10
Cab door window regulator			Heater exhaust tube, primary		
installation . . . . .	11-6c	11-8	and secondary, replacement:		
Cab door window regulator			Installation . . . . .	14-30b	14-46
removal . . . . .	11-6b	11-8	Removal . . . . .	14-30a	14-46
Window regulator handle			Heater, manifold, (covered)		
installation . . . . .	11-6d	11-8	replacement:		
Window regulator handle			Cover installation . . . . .	3-30l	3-64
removal . . . . .	11-6a	11-8	Cover removal . . . . .	3-30a	3-60
Handle, cab, replacement:			Elbow installation . . . . .	3-30h	3-62
Installation . . . . .	11-16b	11-25	Elbow removal . . . . .	3-30e	3-62
Removal . . . . .	11-16a	11-25	Fuel filter installation . . . . .	3-30g	3-62
Hardtop maintenance:			Fuel filter removal . . . . .	3-30f	3-62
Assembly . . . . .	14-14c	14-20	Fuel nozzle installation . . . . .	3-30j	3-64
Disassembly . . . . .	14-14b	14-20	Fuel nozzle removal . . . . .	3-30c	3-60
Installation . . . . .	14-14d	14-21	Fuel pump installation . . . . .	3-30i	3-62
Removal . . . . .	14-14a	14-20	Fuel pump removal . . . . .	3-30d	3-62
Harness, engine coolant heater,			Ignition unit installation . . . . .	3-30k	3-64
replacement:			Ignition unit removal . . . . .	3-30b	3-60
Installation . . . . .	14-9b	14-12	Heater, manifold, (uncovered)		
Removal . . . . .	14-9a	14-12	replacement:		
Headlamp housing, sealed beam			Elbow installation . . . . .	3-31f	3-68
and, maintenance:			Elbow removal . . . . .	3-31e	3-67
Alinement . . . . .	4-39e	4-60	Fuel filter installation . . . . .	3-31h	3-68
Headlamp housing installation..	4-39c	4-58	Fuel filter removal . . . . .	3-31c	3-66
Headlamp housing removal . . . . .	4-39b	4-58	Fuel nozzle installation . . . . .	3-31j	3-68
Sealed beam installation . . . . .	4-39d	4-58	Fuel nozzle removal . . . . .	3-31a	3-66
Sealed beam removal . . . . .	4-39a	4-58	Fuel pump installation . . . . .	3-31g	3-68
Headlight bracket replacement:			Fuel pump removal . . . . .	3-31d	3-66
Installation . . . . .	11-12b	11-18	Ignition unit installation . . . . .	3-31i	3-68
Removal . . . . .	11-12a	11-18	Ignition unit removal . . . . .	3-31b	3-66
Headlight dimmer switch			Heater pad, battery box,		
replacement:			replacement:		
Installation . . . . .	4-28b	4-44	Installation . . . . .	14-11b	14-16
Removal . . . . .	4-28a	4-44	Removal . . . . .	14-11a	14-16



INDEX (Contd)

	Para	Page		Para	Page
Heater, personnel, inlet and outlet hose replacement:			Hose and adapter, turbocharger oil drain tube, replacement:		
Installation . . . . .	3-44b	3-102	Installation . . . . .	3-19b	3-30
Removal . . . . .	3-44a	3-102	Removal . . . . .	3-19a	3-30
Heater switches, primary and secondary, replacement:			Hoses, oil cooler tube and, replacement:		
Installation . . . . .	14-33b	14-52	Installation . . . . .	3-48b	3-108
Removal . . . . .	14-33a	14-52	Removal . . . . .	3-48a	3-108
Heating systems, table 2-4:			Hose, water manifold and, replacement:		
Electrical troubleshooting . . . . .		2-136	Installation . . . . .	3-45b	3-103
Hinges, cab door and, replacement:			Removal . . . . .	3-45a	3-103
Cab door hinges installation . . . . .	11-4c	11-4	Hot water heater, personnel, replacement:		
Cab door hinges removal . . . . .	11-4b	11-4	Brackets installation . . . . .	11-42d	11-82
Cab door installation . . . . .	11-4d	11-4	Brackets removal . . . . .	11-42c	11-82
Cab door removal . . . . .	11-4a	11-4	Heater installation . . . . .	11-42e	11-82
Hinges, hood, replacement:			Heater removal . . . . .	11-42b	11-80
Installation . . . . .	11-15b	11-24	Hoses and adapters installation . . . . .	11-42f	11-84
Removal . . . . .	11-15a	11-24	Hoses and adapters removal . . . . .	11-42a	11-80
Hood and radiator cover replacement:			Hot water personnel heater blower motor resistor replacement:		
Installation . . . . .	14-13b	14-18	Installation . . . . .	4-35b	4-53
Removal . . . . .	14-13a	14-18	Removal . . . . .	4-35a	4-53
Hood fastener replacement:			Hot water personnel heater control switch replacement:		
Hood holddown fastener and bracket installation . . . . .	11-13f	11-21	Installation . . . . .	4-34b	4-52
Hood holddown fastener and bracket removal . . . . .	11-13a	11-20	Removal . . . . .	4-34a	4-52
Hood support hook installation . . . . .	11-13d	11-20	Housing, blackout drive lamp and, replacement:		
Hood support hook removal . . . . .	11-13c	11-20	Blackout drive lamp housing installation . . . . .	4-42c	4-64
Safety latch installation . . . . .	11-13e	11-21	Blackout drive lamp housing removal . . . . .	4-42b	4-64
Safety latch removal . . . . .	11-13b	11-20	Blackout drive lamp installation . . . . .	4-42d	4-64
Hood hinges replacement:			Blackout drive lamp removal . . . . .	4-42a	4-64
Installation . . . . .	11-15b	11-24	Housing, rear composite lamps and, replacement:		
Removal . . . . .	11-15a	11-24	Rear composite lamp housing installation . . . . .	4-46c	4-70
Hood maintenance:			Rear composite lamp housing removal . . . . .	4-46b	4-70
Installation . . . . .	11-14c	11-22	Rear composite lamps installation . . . . .	4-46d	4-70
Removal . . . . .	11-14a	11-22	Rear composite lamps removal . . . . .	4-46a	4-70
Repair . . . . .	11-14b	11-22	Housing, and bracket, front composite lamps, replacement:		
Hook, pintle, maintenance:			Composite light housing installation . . . . .	4-41c	4-62
Cleaning and inspection . . . . .	10-4c	10-4	Composite light housing removal . . . . .	4-41b	4-62
Pintle hook installation . . . . .	10-4e	10-5	Composite lamps installation . . . . .	4-41d	4-62
Pintle hook latch installation . . . . .	10-4d	10-5	Composite lamps removal . . . . .	4-41a	4-62
Pintle hook latch removal . . . . .	10-4b	10-4			
Pintle hook removal . . . . .	10-4a	10-4			
Horizontal leveling worm drivechain replacement:					
Installation . . . . .	12-85b	12-136			
Removal . . . . .	12-85a	12-136			
Horn button replacement:					
Installation . . . . .	4-30b	4-46			
Removal . . . . .	4-30a	4-46			
Hose, airbrake, replacement:					
Installation . . . . .	8-34b	8-82			
Removal . . . . .	8-34a	8-82			

INDEX (Contd)

	Para	Page		Para	Page
Housing, thermostat, and hose replacement:			Hydraulic oil level gage and screen replacement:		
Installation . . . . .	3-46c	3-104	Installation . . . . .	12-88b	12-143
Removal . . . . .	3-46a	3-104	Removal . . . . .	12-88a	12-143
Testing . . . . .	3-46b	3-104	Hydraulic pump universal joint maintenance:		
Housing, water pump, and water pump replacement:			Assembly . . . . .	12-90d	12-146
Water pump housing installation . . . . .	3-47d	3-106	Cleaning and inspection . . . . .	12-90c	12-146
Water pump housing removal . . . . .	3-47a	3-106	Disassembly . . . . .	12-90b	12-146
Water pump installation . . . . .	3-47c	3-106	Installation . . . . .	12-90e	12-147
Water pump removal . . . . .	3-47b	3-106	Removal . . . . .	12-90a	12-146
How to use this manual . . . . .		v	Hydraulic tank replacement:		
Hub and drum, front, maintenance:			Installation . . . . .	12-95b	12-158
Cleaning and inspection . . . . .	9-3b	9-6	Removal . . . . .	12-95a	12-158
Installation . . . . .	9-3d	9-7	Hydraulic wheel cylinder replacement:		
Lubrication . . . . .	9-3c	9-7	Installation . . . . .	8-9b	8-24
Removal . . . . .	9-3a	9-6	Removal . . . . .	8-9a	8-24
Hub and drum, rear, maintenance:					
Cleaning and inspection . . . . .	9-4b	9-8	<b>I</b>		
Installation . . . . .	9-4d	9-10	Indicator, switch, front-wheel drive lock-in, replacement:		
Lubrication . . . . .	9-4c	9-9	Indicator lamp installation . . . . .	4-36c	4-54
Removal . . . . .	9-4a	9-8	Indicator lamp removal . . . . .	4-36b	4-54
Hydraulic systems, service brake and, maintenance index . . . . .	8-6	8-18	Switch installation . . . . .	4-36d	4-54
Hydraulic brake line, flexible, modification:			Switch removal . . . . .	4-36a	4-54
Installation . . . . .	8-16c	8-44	Indicator lamp, turn signal control, and replacement:		
Modification . . . . .	8-16b	8-43	Installation . . . . .	4-19b	4-34
Removal . . . . .	8-16a	8-42	Removal . . . . .	4-19a	4-34
Hydraulic brake line replacement:			Indicators, gages, and warning system, table 2-4:		
Installation . . . . .	8-15b	8-40	Electrical troubleshooting . . . . .		2-121
Removal . . . . .	8-15a	8-40	Inlet and outlet hose, personnel heater, replacement:		
Hydraulic hoist control linkage maintenance (M342A2):			Installation . . . . .	3-44b	3-102
Inspection . . . . .	13-22b	13-38	Removal . . . . .	3-44a	3-102
Installation . . . . .	13-22c	13-38	Inlet tube, delivery pump, replacement (M49A2C):		
Removal . . . . .	13-22a	13-38	Installation . . . . .	12-33b	12-52
Hydraulic hoist pump propeller shaft maintenance:			Removal . . . . .	12-33a	12-52
Inspection . . . . .	12-14b	12-19	Inspection and servicing instructions, general . . . . .	2-5	2-1
Installation . . . . .	12-14c	12-19	Inspection hole cover, cab door, replacement:		
Removal . . . . .	12-14a	12-19	Installation . . . . .	11-2b	11-2
Hydraulic lines outrigger, replacement:			Removal . . . . .	11-2a	11-2
Installation . . . . .	12-91b	12-151	Inspection procedures, general service and, . . . . .	2-10	2-3
Removal . . . . .	12-91a	12-148	Instructions for servicing and specific instructions . . . . .	2-6	2-2
Hydraulic master cylinder replacement:					
Installation . . . . .	8-10c	8-28			
Internal leakage test . . . . .	8-10a	8-26			
Removal . . . . .	8-10b	8-28			

INDEX (Contd)

	Para	Page		Para	Page
Instrument cluster replacement:			Kit, chemical agent alarm mounting,		
Assembly . . . . .	4-10c	4-18	replacement:		
Disassembly . . . . .	4-10b	4-18	Installation . . . . .	14-46b	14-80
Installation . . . . .	4-10d	4-18	Removal . . . . .	14-46a	14-78
Removal . . . . .	4-10a	4-16	Kit, decontamination mounting,		
Instruments, sending units,			replacement:		
switches, and horn maintenance			Installation . . . . .	14-45b	14-76
index . . . . .	4-9	4-15	Removal . . . . .	14-45a	14-76
Insulation, thermal barrier,			Kit, fire extinguisher mounting,		
replacement:			replacement:		
Installation . . . . .	14-10b	14-14	Installation . . . . .	14-47b	14-82
Removal . . . . .	14-10a	14-14	Removal . . . . .	14-47a	14-82
Intake tubes, air, replacement:			Kit, fixed seatbelt, replacement:		
Installation . . . . .	14-38b	14-60	Installation of companion		
Removal . . . . .	14-38a	14-60	seatbelts . . . . .	14-55d	14-95
(In-tank), fuel pump, fuse			Installation of driver's seatbelts .	14-55b	14-94
replacement:			Removal of companion seatbelts.	14-55c	14-94
Installation . . . . .	3-23b	3-33	Removal of driver's seatbelts . . . .	14-55a	14-94
Removal . . . . .	3-23a	3-33	Kit, floating seatbelt, replacement:		
(In-tank), fuel pump, maintenance:			Installation of companion		
Assembly . . . . .	3-26e	3-46	seatbelts . . . . .	14-56d	14-97
Cleaning and inspection . . . . .	3-26d	3-46	Installation of driver's seatbelts .	14-56b	14-96
Disassembly . . . . .	3-26c	3-44	Removal of companion seatbelts.	14-56c	14-96
Installation . . . . .	3-26f	3-48	Removal of driver's seatbelts . . . .	14-56a	14-96
Removal . . . . .	3-26b	3-43	Kit, machine gun mount, replacement:		
Testing fuel pump pressure . . . . .	3-26a	3-42	Assembly . . . . .	14-43c	14-72
Intermediate propeller shaft			Disassembly . . . . .	14-43b	14-72
maintenance (M36A2):			Installation . . . . .	14-43d	14-74
Assembly . . . . .	7-3d	7-8	Removal . . . . .	14-43a	14-70
Cleaning and inspection . . . . .	7-3c	7-8	Kits, mounting, maintenance index	14-42	14-70
Disassembly . . . . .	7-3b	7-6	Kit, rifle mounting, replacement:		
Installation . . . . .	7-3e	7-8	Installation . . . . .	14-44b	14-75
Removal . . . . .	7-3a	7-6	Removal . . . . .	14-44a	14-75
Intermediate turn signal			Kit, troop seat center mounted,		
replacement:			replacement:		
Installation . . . . .	4-40b	4-61	Installation . . . . .	14-54b	14-93
Removal . . . . .	4-40a	4-61	Removal . . . . .	14-54a	14-92
Internal components, major,			Knuckle boot, steering, replacement:		
location and description . . . . .	1-12	1-12	Installation . . . . .	7-9b	7-22
Intervals . . . . .	2-8	2-2	Removal . . . . .	7-9a	7-22
<b>J</b>			<b>L</b>		
Jack, stiff-leg, replacement:			Lamp, headlight high beam		
Installation . . . . .	12-103b	12-170	indicator and, replacement:		
Removal . . . . .	12-103a	12-170	Installation . . . . .	4-17b	4-32
Joint, universal, maintenance:			Removal . . . . .	4-17a	4-32
Assembly . . . . .	7-4c	7-12	Lamp, dome, and housing		
Cleaning and inspection . . . . .	7-4b	7-12	replacement:		
Disassembly . . . . .	7-4a	7-10	Installation . . . . .	12-61b	12-98
<b>K</b>			Removal . . . . .	12-61a	12-98
Kit, A-frame, replacement:					
Inspection . . . . .	14-41b	14-68			
Installation . . . . .	14-41c	14-68			
Removal . . . . .	14-41a	14-66			

INDEX (Contd)

	Para	Page		Para	Page
Lashing hooks, cab soft top			PTO lock adjustment . . . . .	6-2d	6-8
turnbuttons and, replacement:			Removal . . . . .	6-2a	6-1
Lashing hooks installation . . . . .	11-25c	11-41	Linkage, clutch control, maintenance:		
Lashing hooks removal . . . . .	11-25b	11-41	Adjustment . . . . .	3-10c	3-18
Turnbuttons and snap shank			Installation . . . . .	3-10b	3-16
installation . . . . .	11-25d	11-41	Removal . . . . .	3-10a	3-14
Turnbuttons and snap shank			Linkage, hydraulic hoist control,		
removal . . . . .	11-25a	11-41	replacement (M342A2):		
Leveling worm cover and drive			Inspection . . . . .	13-22b	13-38
chain maintenance:			Installation . . . . .	13-22c	13-38
Horizontal drivechain			Removal . . . . .	13-22a	13-38
adjustment . . . . .	12-87b	12-140	Linkage, power divider control		
Horizontal drivechain cover			lever and, replacement (M764):		
installation . . . . .	12-87c	12-140	Inspection . . . . .	13-23b	13-40
Horizontal drivechain cover			Installation . . . . .	13-23c	13-40
removal . . . . .	12-87a	12-140	Removal . . . . .	13-23a	13-40
Vertical drivechain adjustment..	12-87e	12-142	Link, drag, replacement:		
Vertical drivechain cover			Installation . . . . .	9-11b	9-18
installation . . . . .	12-87f	12-142	Removal . . . . .	9-11a	9-18
Vertical drivechain cover			Location and contents of warning,		
removal . . . . .	12-87d	12-142	caution, and data plates . . . . .	1-13	1-14
Lever, brake pedal, replacement:			Location and description of major		
Installation . . . . .	8-13b	8-36	external components . . . . .	1-11	1-10
Removal . . . . .	8-13a	8-36	Location and description of major		
Lever cover, transmission gearshift			internal components . . . . .	1-12	1-12
and transfer case, replacement:			Low air buzzer replacement:		
Installation . . . . .	14-12b	14-17	Installation . . . . .	4-27b	4-42
Removal . . . . .	14-12a	14-17	Removal . . . . .	4-27a	4-42
Levers, operation, maintenance:			Low air pressure switch replacement:		
Assembly . . . . .	12-96c	12-160	Installation . . . . .	4-25b	4-40
Disassembly . . . . .	12-96b	12-160	Removal . . . . .	4-25a	4-40
Installation . . . . .	12-96d	12-161	Lower, upper and, radiator hose		
Removal . . . . .	12-96a	12-160	replacement:		
Lighting system, table 2-4:			Lower hose installation . . . . .	3-43d	3-100
Electrical troubleshooting . . . . .		2-101	Lower hose removal . . . . .	3-43b	3-100
Light switch replacement:			Upper hose installation . . . . .	3-43c	3-100
Installation . . . . .	4-18b	4-33	Upper hose removal . . . . .	3-43a	3-100
Removal . . . . .	4-18a	4-33			
Limited storage:			<b>M</b>		
Inspection in limited storage . . . .	15-11	15-3	Machine gun mount kit replacement:		
Limited storage instructions . . . .	15-10	15-3	Assembly . . . . .	14-43c	14-72
Removal from limited storage . . . .	15-12	15-3	Disassembly . . . . .	14-43b	14-72
Scope . . . . .	15-9	15-2	Installation . . . . .	14-43d	14-74
Linkage and transfer case controls			Removal . . . . .	14-43a	14-70
maintenance (wo/PTO):			Magnetic starter relay and mounting		
Cleaning and inspection . . . . .	6-3b	6-10	bracket replacement:		
Installation . . . . .	6-3c	6-10	Installation . . . . .	4-6b	4-10
Removal . . . . .	6-3a	6-10	Removal . . . . .	4-6a	4-10
Linkage and transfer case controls			Maintenance allocation chart,		
maintenance (w/PTO):			Appendix B:		
Cleaning and inspection . . . . .	6-2b	6-4	Explanation of columns in the		
Installation . . . . .	6-2c	6-4	MAC . . . . .	B-3	B-2
			General . . . . .	B-1	B-1
			Maintenance functions . . . . .	B-2	B-1

INDEX (Contd)

	Para	Page		Para	Page
Maintenance procedures, detailed .		viii	Engine . . . . .	2-12	2-28
Manhole cover, water tank, (M50A3)			Exhaust system . . . . .	2-12	2-32
replacement:			Fifth wheel . . . . .	2-12	2-45
Installation . . . . .	12-49b	12-80	Frame and brackets . . . . .	2-12	2-41
Removal . . . . .	12-49a	12-80	Fuel system . . . . .	2-12	2-35
Manhole cover, water tank,			Fuel tank (M49A2C) . . . . .	2-12	2-47
replacement (M50A2):			General . . . . .	2-12	2-24
Installation . . . . .	12-48b	12-79	Manifold heater system . . . . .	2-12	2-33
Removal . . . . .	12-48a	12-78	Nonelectrical gages . . . . .	2-12	2-44
Manifold heater (covered)			Outriggers (M764) . . . . .	2-12	2-47
replacement:			Personnel fuel burning heater/ power plant heater kit . . . . .	2-12	2-50
Cover installation . . . . .	3-30l	3-64	Personnel hot water heater . . . . .	2-12	2-35
Cover removal . . . . .	3-30a	3-60	Power takeoff . . . . .	2-12	2-43
Elbow installation . . . . .	3-30h	3-62	Propeller shafts . . . . .	2-12	2-37
Elbow removal . . . . .	3-30e	3-62	Steering . . . . .	2-12	2-39
Fuel filter installation . . . . .	3-30g	3-62	Suspension . . . . .	2-12	2-42
Fuel filter removal . . . . .	3-30f	3-62	Transfer case . . . . .	2-12	2-36
Fuel nozzle installation . . . . .	3-30j	3-64	Transmission . . . . .	2-12	2-35
Fuel nozzle removal . . . . .	3-30c	3-60	Water tank (M50A2, M50A3) . . . . .	2-12	2-49
Fuel pump installation . . . . .	3-30i	3-62	Wheels and tires . . . . .	2-12	2-38
Fuel pump removal . . . . .	3-30d	3-62	Winch . . . . .	2-12	2-42
Ignition unit installation . . . . .	3-30k	3-64	Meter, gallon, replacement (M49A2C):		
Ignition unit removal . . . . .	3-30b	3-60	Installation . . . . .	12-31b	12-50
Manifold heater switch replacement:			Removal . . . . .	12-31a	12-50
Installation . . . . .	4-22b	4-37	Meter outlet tube replacement (M49A2C):		
Removal . . . . .	4-22a	4-37	Installation . . . . .	12-37b	12-57
Manifold heater (uncovered)			Removal . . . . .	12-37a	12-57
replacement:			Meter-to-filter tube replacement (M49A2C):		
Elbow installation . . . . .	3-31f	3-68	Installation . . . . .	12-30b	12-49
Elbow removal . . . . .	3-31e	3-67	Removal . . . . .	12-30a	12-49
Fuel filter installation . . . . .	3-31h	3-68	Mirror and brackets replacement:		
Fuel filter removal . . . . .	3-31c	3-66	Installation . . . . .	11-36b	11-72
Fuel nozzle installation . . . . .	3-31j	3-68	Removal . . . . .	11-36a	11-72
Fuel nozzle removal . . . . .	3-31a	3-66	Motor, windshield wiper blade, arm, and, replacement:		
Fuel pump installation . . . . .	3-31g	3-68	Windshield wiper arm installation . . . . .	11-34e	11-68
Fuel pump removal . . . . .	3-31d	3-66	Windshield wiper arm removal . . . . .	11-34b	11-68
Ignition unit installation . . . . .	3-31i	3-68	Windshield wiper blade installation . . . . .	11-34f	11-68
Ignition unit removal . . . . .	3-31b	3-66	Windshield wiper blade removal . . . . .	11-34a	11-68
Manifold, water pump, replacement (M50A2, M50A3):			Windshield wiper motor installation . . . . .	11-34d	11-68
Installation . . . . .	12-34b	12-53	Windshield wiper motor removal. . . . .	11-34c	11-68
Removal . . . . .	12-34a	12-53	Motor, starter, replacement:		
Master cylinder, hydraulic, replacement:			Installation . . . . .	4-7b	4-12
Installation . . . . .	8-10c	8-28	Removal . . . . .	4-7a	4-12
Internal leakage test . . . . .	8-10a	8-26	Mount, floodlamp housing and, maintenance:		
Removal . . . . .	8-10b	8-28	Floodlamp housing and mount assembly . . . . .	4-43c	4-66
Mechanical systems trouble- shooting:			Floodlamp housing and mount disassembly . . . . .	4-43b	4-66
Clutch . . . . .	2-12	2-36			
Cooling system . . . . .	2-12	2-34			
Differentials . . . . .	2-12	2-37			
Dump body (M342A2) . . . . .	2-12	2-45			
Earth boring and polesetting (M764) . . . . .	2-12	2-46			

INDEX (Contd)

	Para	Page		Para	Page
Floodlamp housing and mount installation . . . . .	4-43d	4-67	Oil filter, engine, and body maintenance:		
Floodlamp housing and mount removal . . . . .	4-43a	4-66	Body assembly . . . . .	3-7e	3-12
Mounting bracket, magnetic starter relay and, replacement:			Body disassembly . . . . .	3-7c	3-11
Installation . . . . .	4-6b	4-10	Cleaning and inspection . . . . .	3-7d	3-12
Removal . . . . .	4-6a	4-10	Draining oil . . . . .	3-7a	3-10
Mounting bracket, alternator (60 amp) and, replacement:			Oil filter installation . . . . .	3-7f	3-12
Adjustment . . . . .	4-3c	4-6	Oil filter removal . . . . .	3-7b	3-10
Installation . . . . .	4-3b	4-6	Oil inlet tube and adapter, turbocharger, replacement:		
Removal . . . . .	4-3a	4-4	Installation . . . . .	3-18b	3-28
Mounting kit, chemical agent alarm, replacement:			Removal . . . . .	3-18a	3-28
Installation . . . . .	14-46b	14-80	Oil pan shroud and exhaust tube replacement:		
Removal . . . . .	14-46a	14-78	Installation . . . . .	14-7b	14-9
Mounting kit, fire extinguisher, replacement:			Removal . . . . .	14-7a	14-9
Installation . . . . .	14-47b	14-82	Oil pressure gage, battery and generator gage, fuel gage, and engine temperature gage replacement:		
Removal . . . . .	14-47a	14-82	Installation . . . . .	4-12b	4-22
Mounting kit, rifle, replacement:			Removal . . . . .	4-12a	4-22
Installation . . . . .	14-44b	14-75	Oil pressure sending unit replacement:		
Removal . . . . .	14-44a	14-75	Installation . . . . .	4-23b	4-38
<b>N</b>					
Nozzle, fuel hose and, replacement (M49A2C):			Removal . . . . .	4-23a	4-38
Installation . . . . .	12-24b	12-42	Oil seal assembly, front axle, replacement:		
Removal . . . . .	12-24a	12-42	Installation . . . . .	7-7b	7-20
Nozzle holder, fuel and water tank, replacement:			Removal . . . . .	7-7a	7-20
Installation . . . . .	12-25b	12-44	Operating control systems:		
Removal . . . . .	12-25a	12-44	Accelerator controls system operation . . . . .	1-18c	1-41
<b>O</b>					
Oil cooler tube and hoses replacement:			Clutch control system operation . . . . .	1-18f	1-44
Installation . . . . .	3-48b	3-108	Manifold heater system operation . . . . .	1-18b	1-40
Removal . . . . .	3-48a	3-108	Parking brake system operation . . . . .	1-18d	1-42
Oil dipstick tube replacement:			Starting system operation . . . . .	1-18a	1-38
Installation . . . . .	3-5b	3-6	Steering system operation . . . . .	1-18e	1-43
Removal . . . . .	3-5a	3-6	Transfer case control system operation . . . . .	1-18g	1-45
Oil draintube, rear winch, replacement (M764):			Operation and description, STE/ICE . . . . .	2-20	2-148
Installation . . . . .	13-16b	13-28	Operation levers maintenance:		
Removal . . . . .	13-16a	13-28	Assembly . . . . .	12-96c	12-160
Oil draintubes, rear winch, replacement (M756A2):			Disassembly . . . . .	12-96b	12-160
End frame draintube installation . . . . .	13-17c	13-29	Installation . . . . .	12-96d	12-161
End frame draintube removal . . . . .	13-17b	13-29	Removal . . . . .	12-96a	12-160
Gearcase draintube installation . . . . .	13-17d	13-29	Operation, compressed air and brake system:		
Gearcase draintube removal . . . . .	13-17a	13-29	Brake system operation . . . . .	1-21b	1-62
			Compressed air system operation . . . . .	1-21a	1-60

INDEX (Contd)

	Para	Page		Para	Page
Operation, electrical systems:			Overturn tubes replacement		
Battery system operation . . . . .	1-20a	1-56	(M49A2C):		
Gage and warning system			Installation . . . . .	12-26b	12-45
operation . . . . .	1-20e	1-59	Removal . . . . .	12-26a	12-45
Generating system operation . . . .	1-20c	1-58			
Heating system operation . . . . .	1-20d	1-58	<b>P</b>		
Starting system operation . . . . .	1-20b	1-57	Pad, engine front mount, replacement:		
Operation, power systems:			Front mount pad installation . . . .	3-2d	3-2
Air intake system operation . . . .	1-19d	1-52	Front mount pad removal . . . . .	3-2a	3-2
Cooling system operation . . . . .	1-19f	1-54	Support plate installation . . . . .	3-2c	3-2
Engine oil system operation . . . .	1-19b	1-48	Support plate removal . . . . .	3-2b	3-2
Exhaust system operation . . . . .	1-19e	1-53	Pad, engine rear mount, replacement:		
Fuel system operation . . . . .	1-19c	1-50	Installation . . . . .	3-3b	3-4
Powertrain system operation . . . .	1-19a	1-46	Removal . . . . .	3-3a	3-4
Operation, special purpose bodies			Panel, side, replacement:		
systems:			Side panel hinges installation . . .	11-11d	11-16
Dump body hydraulic system			Side panel hinges removal . . . . .	11-11b	11-16
operation (M342A2) . . . . .	1-22a	1-64	Side panel installation . . . . .	11-11e	11-17
Earth boring, polesetting and			Side panel removal . . . . .	11-11a	11-16
rear winch systems operation			Thumb cranks installation . . . . .	11-11f	11-17
(M764) . . . . .	1-22b	1-66	Thumb cranks removal . . . . .	11-11c	11-16
Fuel tank system operation			Parking brake cable replacement:		
(M49A2C) . . . . .	1-22e	1-70	Installation . . . . .	8-4b	8-14
Outrigger hydraulic system			Removal . . . . .	8-4a	8-12
operation (M764) . . . . .	1-22c	1-68	Parking brakedrum replacement:		
Rear winch and pipeline systems			Installation . . . . .	8-2b	8-2
operation (M756A2) . . . . .	1-22f	1-72	Removal . . . . .	8-2a	8-2
Water tank system operation			Parking brake lever replacement:		
(M50A2 and M50A3) . . . . .	1-22d	1-70	Installation . . . . .	8-5b	8-16
Operation reference index,			Removal . . . . .	8-5a	8-16
principles . . . . .	1-17	1-37	Parking brakeshoe maintenance:		
Outlet tube, delivery pump,			Assembly . . . . .	8-3d	8-8
replacement (M49A2C):			Clearance adjustment . . . . .	8-3f	8-10
Installation . . . . .	12-32b	12-51	Cleaning and inspection . . . . .	8-3c	8-6
Removal . . . . .	12-32a	12-51	Disassembly . . . . .	8-3b	8-6
Outlet tube, meter,			Installation . . . . .	8-3e	8-8
replacement (M49A2C):			Removal . . . . .	8-3a	8-4
Installation . . . . .	12-37b	12-57	Parts, repair . . . . .	2-3	2-1
Removal . . . . .	12-37a	12-57	Pedal, brake, adjustment . . . . .	8-14	8-38
Outrigger hydraulic lines			Pedal shaft support replacement:		
replacement:			Installation . . . . .	3-11b	3-19
Installation . . . . .	12-91b	12-151	Removal . . . . .	3-11a	3-19
Removal . . . . .	12-91a	12-148	Personnel heater air vent		
Outside door handle, inside door			replacement:		
handle, and cab door lock			Installation . . . . .	11-40b	11-77
replacement:			Removal . . . . .	11-40a	11-77
Cab door lock installation . . . . .	11-7d	11-10	Personnel heater, cargo body,		
Cab door lock removal . . . . .	11-7c	11-10	replacement:		
Inside door handle installation ..	11-7e	11-10	Installation . . . . .	14-17b	14-26
Inside door handle removal . . . . .	11-7b	11-10	Removal . . . . .	14-17a	14-26
Outside door handle installation	11-7f	11-10	Personnel heater control box,		
Outside door handle removal . . . .	11-7a	11-10	cargo body, replacement:		
			Installation . . . . .	14-21b	14-31
			Removal . . . . .	14-21a	14-31

INDEX (Contd)

	Para	Page		Para	Page
Personnel heater control box replacement:			Personnel heater supply hose replacement:		
Installation . . . . .	14-3b	14-3	Installation . . . . .	11-38b	11-75
Removal . . . . .	14-3a	14-3	Removal . . . . .	11-38a	11-75
Personnel heater control cables replacement:			Personnel heater blower motor resistor, hot water, replacement:		
Adjustment . . . . .	11-41c	11-78	Installation . . . . .	4-35b	4-53
Installation . . . . .	11-41b	11-78	Removal . . . . .	4-35a	4-53
Removal . . . . .	11-41a	11-78	Personnel hot water heater replacement:		
Personnel heater defroster hoses replacement:			Brackets installation . . . . .	11-42d	11-82
Installation . . . . .	11-43b	11-85	Brackets removal . . . . .	11-42c	11-82
Removal . . . . .	11-43a	11-85	Heater installation . . . . .	11-42e	11-82
Personnel heater diverter and duct, cargo body, replacement:			Heater removal . . . . .	11-42b	11-80
Installation . . . . .	14-23b	14-34	Hoses and adapters installation . . . . .	11-42f	11-84
Removal . . . . .	14-23a	14-34	Hoses and adapters removal . . . . .	11-42a	11-80
Personnel heater diverter replacement:			Pintle hook maintenance:		
Installation . . . . .	11-39b	11-76	Cleaning and inspection . . . . .	10-4c	10-4
Removal . . . . .	11-39a	11-76	Pintle hook installation . . . . .	10-4e	10-5
Personnel heater, fuel burning, replacement:			Pintle hook latch installation . . . . .	10-4d	10-5
Installation . . . . .	14-2b	14-2	Pintle hook removal . . . . .	10-4a	10-4
Removal . . . . .	14-2a	14-2	Pintle hook latch removal . . . . .	10-4b	10-4
Personnel heater fuel filter, cargo body, replacement:			Pioneer tool bracket kit replacement:		
Installation . . . . .	14-20b	14-30	Installation . . . . .	11-32b	11-61
Removal . . . . .	14-20a	14-30	Removal . . . . .	11-32a	11-57
Personnel heater fuel filter replacement:			Pipeline construction cab protector replacement:		
Installation . . . . .	14-5b	14-6	Installation . . . . .	12-105b	12-172
Removal . . . . .	14-5a	14-6	Removal . . . . .	12-105a	12-172
Personnel heater fuel line, cargo body, replacement:			Pipeline construction tailgate replacement:		
Installation . . . . .	14-22b	14-32	Installation . . . . .	12-107b	12-176
Removal . . . . .	14-22a	14-32	Removal . . . . .	12-107a	12-176
Personnel heater fuel pump, cargo body, replacement:			Pipeline construction toolbox maintenance:		
Installation . . . . .	14-19b	14-29	Assembly . . . . .	12-106c	12-174
Removal . . . . .	14-19a	14-29	Disassembly . . . . .	12-106a	12-174
Personnel heater fuel pump replacement:			Inspection . . . . .	12-106b	12-174
Installation . . . . .	14-4b	14-4	Pitman arm replacement:		
Removal . . . . .	14-4a	14-4	Installation . . . . .	9-8b	9-14
Personnel heater inlet and outlet hose replacement:			Removal . . . . .	9-8a	9-14
Installation . . . . .	3-44b	3-102	Plate, data, replacement:		
Removal . . . . .	3-44a	3-102	Installation . . . . .	11-37b	11-74
Personnel heater mounting brackets, cargo body, replacement:			Removal . . . . .	11-37a	11-74
Installation . . . . .	14-18b	14-28	Plate, step, replacement:		
Removal . . . . .	14-18a	14-28	Installation . . . . .	12-104b	12-171
			Removal . . . . .	12-104a	12-171
			PMCS procedures, specific . . . . .	2-11	2-3
			Power divider control lever and linkage replacement (M764):		
			Adjustment . . . . .	13-23c	13-40
			Installation . . . . .	13-23b	13-40
			Removal . . . . .	13-23a	13-40



INDEX (Contd)

	Para	Page		Para	Page
Power divider propeller shaft replacement (M764):			Primary heater air inlet duct replacement:		
Inspection . . . . .	13-21b	13-36	Installation . . . . .	14-31b	14-47
Installation . . . . .	13-21c	13-36	Removal . . . . .	14-31a	14-47
Removal . . . . .	13-21a	13-36	Primary heater and duct replacement:		
Power switch maintenance:			Duct installation . . . . .	14-32c	14-50
Assembly . . . . .	12-75c	12-122	Duct removal . . . . .	14-32b	14-50
Disassembly . . . . .	12-75b	12-122	Heater installation . . . . .	14-32d	14-51
Installation . . . . .	12-75d	12-122	Heater removal . . . . .	14-32a	14-48
Removal . . . . .	12-75a	12-122	Primary heater auxiliary duct replacement:		
Power systems operation:			Installation . . . . .	14-34b	14-54
Air intake system operation . . . . .	1-19d	1-52	Removal . . . . .	14-34a	14-54
Cooling system operation . . . . .	1-19f	1-54	Primary heater fuel filter replacement:		
Engine oil system operation . . . . .	1-19b	1-48	Installation . . . . .	14-27b	14-39
Exhaust system operation . . . . .	1-19e	1-53	Removal . . . . .	14-27a	14-39
Fuel system operation . . . . .	1-19c	1-50	Primary heater fuel lines replacement:		
Powertrain system operation . . . . .	1-19a	1-46	Filter-to-pump inlet tube installation . . . . .	14-28d	14-40
Power takeoff (PTO) shift linkage, transmission, maintenance:			Filter-to-pump inlet tube removal . . . . .	14-28c	14-40
Adjustment . . . . .	13-20c	13-34	Fuel heater-to-adapter tube installation . . . . .	14-28h	14-43
Inspection . . . . .	13-20b	13-34	Fuel heater-to-adapter tube removal . . . . .	14-28g	14-43
Installation . . . . .	13-20d	13-35	Fuel tank shutoff-to-filter hose installation . . . . .	14-28b	14-40
Removal . . . . .	13-20a	13-34	Fuel tank shutoff-to-filter hose removal . . . . .	14-28a	14-40
Preparation for storage or shipment	1-4	1-1	Pump outlet-to-adapter tube installation . . . . .	14-28f	14-42
Pressure gage, air, replacement:			Pump outlet-to-adapter tube removal . . . . .	14-28e	14-42
Installation . . . . .	4-11b	4-20	Primary heater fuel pump cover replacement:		
Removal . . . . .	4-11a	4-20	Installation . . . . .	14-26b	14-38
Pressure switch, fuel, replacement:			Removal . . . . .	14-26a	14-38
Installation . . . . .	4-37b	4-56	Primary heater fuel pump replacement:		
Removal . . . . .	4-37a	4-56	Installation . . . . .	14-25b	14-37
Pressure switch, low air, replacement:			Removal . . . . .	14-25a	14-37
Installation . . . . .	4-25b	4-40	Primary heater fuel shutoff and coupling replacement:		
Removal . . . . .	4-25a	4-40	Installation . . . . .	14-29b	14-44
Prevent enemy use, destruction of Army materiel . . . . .	1-3	1-1	Removal . . . . .	14-29a	14-44
Preventive maintenance checks and services (PMCS):			Procedures, specific PMCS . . . . .	2-11	2-3
General . . . . .	2-7	2-2	Propeller shaft, earth boring machine maintenance:		
Preventive maintenance checks and services table 2-1 . . . . .		2-4	Assembly . . . . .	12-89c	12-144
Primary and secondary heater exhaust tube replacement:			Disassembly . . . . .	12-89b	12-144
Installation . . . . .	14-30b	14-46	Installation . . . . .	12-89d	12-144
Removal . . . . .	14-30a	14-46	Removal . . . . .	12-89a	12-144
Primary and secondary heater switches replacement:					
Installation . . . . .	14-33b	14-52			
Removal . . . . .	14-33a	14-52			
Primary fuel filter maintenance:					
Cleaning and inspection . . . . .	3-28d	3-52			
Draining . . . . .	3-28a	3-50			
Filter housing installation . . . . .	3-28f	3-52			
Filter housing removal . . . . .	3-28b	3-50			
Filter installation . . . . .	3-28e	3-52			
Filter removal . . . . .	3-28c	3-52			

INDEX (Contd)

	Para	Page		Para	Page
Propeller shaft, hydraulic hoist pump, replacement:			Pump housing, water, and water pump replacement:		
Installation . . . . .	12-14b	12-19	Water pump housing installation . . . . .	3-47d	3-106
Removal . . . . .	12-14a	12-19	Water pump housing removal . . . . .	3-47a	3-106
Propeller shaft, intermediate, maintenance (M36A2):			Water pump installation. . . . .	3-47c	3-106
Assembly . . . . .	7-3d	7-8	Water pump removal . . . . .	3-47b	3-106
Cleaning and inspection . . . . .	7-3c	7-8	Pump, windshield washer reservoir, tubing, jet, and, replacement:		
Disassembly . . . . .	7-3b	7-6	Windshield washer jet installation . . . . .	11-35f	11-70
Installation . . . . .	7-3e	7-8	Windshield washer jet removal . . . . .	11-35c	11-70
Removal . . . . .	7-3a	7-6	Windshield washer pump installation . . . . .	11-35e	11-70
Propeller shaft maintenance:			Windshield washer pump removal . . . . .	11-35d	11-70
Assembly . . . . .	7-2d	7-4	Windshield washer reservoir installation . . . . .	11-35h	11-71
Cleaning and inspection . . . . .	7-2c	7-3	Windshield washer reservoir removal . . . . .	11-35a	11-70
Disassembly . . . . .	7-2b	7-3	Windshield washer tubing installation . . . . .	11-35g	11-71
Installation . . . . .	7-2e	7-5	Windshield washer tubing removal . . . . .	11-35b	11-70
Removal . . . . .	7-2a	7-2			
Propeller shaft, front winch, replacement:			<b>Q</b>		
Inspection . . . . .	13-6b	13-12	Quick-disconnect coupling half maintenance:		
Installation . . . . .	13-6c	13-12	Installation . . . . .	8-30c	8-74
Removal . . . . .	13-6a	13-12	Leak test . . . . .	8-30a	8-74
Protection valve, trailer, replacement:			Removal . . . . .	8-30b	8-74
Installation . . . . .	8-36b	8-86			
Removal . . . . .	8-36a	8-86	<b>R</b>		
Protector, cab, replacement (M764):			Radiator and brackets replacement:		
Cab protector installation. . . . .	12-84d	12-135	Installation . . . . .	3-42b	3-98
Cab protector removal . . . . .	12-84a	12-133	Removal . . . . .	3-42a	3-96
Mounting tubes installation . . . . .	12-84c	12-134	Radiator and hood cover replacement:		
Mounting tubes removal. . . . .	12-84b	12-134	Installation . . . . .	14-13b	14-18
Pulley and air compressor replacement:			Removal . . . . .	14-13a	14-18
Assembly . . . . .	8-26c	8-64	Rear and front splash guard replacement:		
Disassembly . . . . .	8-26b	8-64	Front splash guard installation: . . . . .	12-102d	12-169
Installation . . . . .	8-26d	8-64	Front splash guard removal . . . . .	12-102a	12-168
Removal . . . . .	8-26a	8-62	Rear splash guard installation . . . . .	12-102c	12-168
Pulley, alternator, replacement:			Rear splash guard removal. . . . .	12-102b	12-168
Installation . . . . .	4-4b	4-8	Rear axle shaft maintenance:		
Removal . . . . .	4-4a	4-8	Cleaning and inspection. . . . .	7-11b	7-26
Pump, delivery, draincock replacement:			Installation. . . . .	7-11c	7-26
Installation . . . . .	12-36b	12-56	Removal . . . . .	7-11a	7-26
Removal . . . . .	12-36a	12-56			
Pump, delivery, rear propeller shaft maintenance (M50A2):					
Inspection . . . . .	12-52b	12-84			
Installation . . . . .	12-52c	12-84			
Removal . . . . .	12-52a	12-84			
Pump, delivery, replacement:					
Installation . . . . .	12-35b	12-54			
Removal . . . . .	12-35a	12-54			

INDEX (Contd)

	Para	Page		Para	Page
Rear bumperette replacement:			Rear splash guard replacement:		
Installation . . . . .	10-6b	10-7	Lower splash guard		
Removal . . . . .	10-6a	10-7	installation . . . . .	12-58d	12-95
Rear cab mount replacement:			Lower splash guard removal . . .	12-58a	12-95
Installation . . . . .	11-23b	11-38	Upper splash guard		
Removal . . . . .	11-23a	11-38	installation . . . . .	12-58c	12-95
Rear compartment door			Upper splash guard removal . . .	12-58b	12-95
maintenance:			Rear spring maintenance:		
Cleaning and inspection . . . . .	12-44b	12-66	Assembly . . . . .	7-18c	7-43
Installation . . . . .	12-44d	12-66	Cleaning and inspection . . . . .	7-18b	7-42
Removal . . . . .	12-44a	12-66	Disassembly . . . . .	7-18a	7-42
Repair . . . . .	12-44c	12-66	Rear spring replacement:		
Rear composite lamps and housing			Installation . . . . .	7-17b	7-40
replacement:			Removal . . . . .	7-17a	7-40
Rear composite lamps housing			Rear spring seat replacement:		
installation . . . . .	4-46c	4-70	Installation . . . . .	7-19b	7-44
Rear composite lamps housing			Removal . . . . .	7-19a	7-44
removal . . . . .	4-46b	4-70	Rear spring wear pad replacement:		
Rear composite lamps			Installation . . . . .	7-21b	7-48
installation . . . . .	4-46d	4-70	Removal . . . . .	7-21a	7-48
Rear composite lamps removal .	4-46a	4-70	Rear winch cable replacement		
Rear, front and, deck replacement:			(M756A2):		
Front deck installation . . . . .	12-110c	12-178	Installation . . . . .	13-13b	13-23
Front deck removal . . . . .	12-110b	12-178	Removal . . . . .	13-13a	13-23
Rear deck installation . . . . .	12-110d	12-179	Rear winch cable replacement		
Rear deck removal . . . . .	12-110a	12-178	(M764):		
Rear hub and drum maintenance:			Inspection: . . . . .	13-10b	13-17
Cleaning and inspection . . . . .	9-4b	9-8	Installation . . . . .	13-10c	13-17
Installation . . . . .	9-4d	9-10	Removal . . . . .	13-10a	13-17
Lubrication . . . . .	9-4c	9-9	Rear winch control lever linkage		
Removal . . . . .	9-4a	9-8	maintenance (M764):		
Rear mount pad, engine, replacement:			Installation . . . . .	13-8b	13-14
Installation . . . . .	3-3b	3-4	Removal . . . . .	13-8a	13-14
Removal . . . . .	3-3a	3-4	Rear winch drivechain		
Rear propeller shaft, delivery pump,			maintenance (M756A2):		
maintenance (M49A2C, M50A3):			Adjustment . . . . .	13-11c	13-18
Inspection . . . . .	12-53b	12-86	Installation . . . . .	13-11b	13-18
Installation . . . . .	12-53c	12-86	Removal . . . . .	13-11a	13-18
Removal . . . . .	12-52a	12-86	Rear winch drum clutch lever and		
Rear propeller shaft, delivery pump,			guide plate replacement (M756A2):		
replacement (M50A2):			Installation . . . . .	13-9b	13-16
Inspection . . . . .	12-52b	12-84	Removal . . . . .	13-9a	13-16
Installation . . . . .	12-52c	12-84	Rear winch replacement (M756A2):		
Removal . . . . .	12-52a	12-84	Installation . . . . .	13-18b	13-32
Rear shackle replacement:			Removal . . . . .	13-18a	13-30
Installation . . . . .	10-5b	10-6	Rear winch oil draintube		
Removal . . . . .	10-5a	10-6	replacement (M764):		
Rear splash guard replacement:			Installation . . . . .	13-16b	13-28
Installation . . . . .	12-109b	12-177	Removal . . . . .	13-16a	13-28
Removal . . . . .	12-109a	12-177	Rear winch oil draintubes		
Rear splash guard, dump body,			replacement (M756A2):		
replacement:			End frame draintube		
Installation . . . . .	12-17b	12-24	installation . . . . .	13-17c	13-29
Removal . . . . .	12-17a	12-24			

INDEX (Contd)

	Para	Page		Para	Page
End frame draintube removal . . .	13-17b	13-29	Roller, auxiliary, replacement:		
Gearcase draintube installation.	13-17d	13-29	Installation. . . . .	12-101b	12-167
Gearcase draintube removal . . .	13-17a	13-29	Removal. . . . .	12-101a	12-167
Receptacle, slave, replacement:			Running board, water can bracket		
Installation. . . . .	14-16b	14-24	and, replacement:		
Removal . . . . .	14-16a	14-24	Running board installation. . . .	11-24c	11-40
Reel, collapsible cable, disassembly:			Running board removal . . . . .	11-24b	11-40
Assembly . . . . .	12-94b	12-156	Water can bracket installation .	11-24d	11-40
Disassembly . . . . .	12-94a	12-156	Water can bracket removal . . . .	11-24a	11-40
Reel, static, replacement (M49A2C):					
Installation. . . . .	12-29b	12-48	<b>S</b>		
Removal . . . . .	12-29a	12-48	Safety switch fuse replacement:		
References, appendix A:			Installation. . . . .	12-59b	12-96
Army regulations. . . . .	A-8	A-3	Removal . . . . .	12-59a	12-96
Common table of allowances . . .	A-10	A-3	Safety valve, air system, replacement:		
Field manuals . . . . .	A-4	A-1	Installation. . . . .	8-20b	8-47
Forms . . . . .	A-3	A-1	Removal . . . . .	8-20a	8-47
Other publications. . . . .	A-7	A-3	Schematic and wiring diagram,		
Publication index. . . . .	A-2	A-1	Appendix E: . . . . .		E-1
Scope . . . . .	A-1	A-1	Screen, hydraulic oil level gage and,		
Technical bulletins. . . . .	A-6	A-2	replacement:		
Technical catalog . . . . .	A-9	A-3	Installation . . . . .	12-88b	12-143
Technical manuals. . . . .	A-5	A-2	Removal . . . . .	12-88a	12-143
Reflector replacement:			Sealed beam and headlamp		
Installation. . . . .	11-44b	11-86	housing maintenance:		
Removal . . . . .	11-44a	11-86	Alinement . . . . .	4-39e	4-60
Reflector, van, replacement. . . . .	12-70	12-110	Headlamp housing installation .	4-39c	4-58
Regulator, 100 AMP alternator,			Headlamp housing removal . . .	4-39b	4-58
replacement:			Sealed beam installation . . . . .	4-39d	4-58
Installation. . . . .	14-52b	14-90	Sealed beam removal. . . . .	4-39a	4-58
Removal . . . . .	14-52a	14-90	Seat adjuster, driver's seat cushion,		
Regulator valve replacement:			backrest, frame, and, replacement:		
Installation. . . . .	14-40b	14-64	Driver's seat adjuster		
Removal . . . . .	14-40a	14-64	installation . . . . .	11-29e	11-50
Repair parts . . . . .	2-3	2-1	Driver's seat adjuster removal. .	11-29d	11-50
Reporting of errors . . . . .		ii	Driver's seat backrest		
Reporting repairs . . . . .	2-9	2-3	installation . . . . .	11-29g	11-50
Reservoirs, air, replacement			Driver's seat backrest removal .	11-29b	11-50
(M275A2 and M342A2):			Driver's seat cushion		
Installation. . . . .	8-23b	8-52	installation . . . . .	11-29h	11-51
Removal . . . . .	8-23a	8-52	Driver's seat cushion removal . .	11-29a	11-50
Reservoirs, air, replacement (M764):			Driver's seat frame		
Installation. . . . .	8-25b	8-60	installation . . . . .	11-29f	11-50
Removal . . . . .	8-25a	8-60	Driver's seat frame removal . . .	11-29c	11-50
Reservoirs, air, replacement:			Seat backrest cushion and earth		
Installation. . . . .	8-24b	8-56	boring machine seat replacement:		
Removal . . . . .	8-24a	8-54	Installation . . . . .	12-93b	12-155
Rifle mounting kit replacement:			Removal . . . . .	12-93a	12-155
Installation . . . . .	14-44b	14-75	Seatbelt kit, fixed, replacement:		
Removal . . . . .	14-44a	14-75	Installation of companion		
Rod, tie, and tie rod end replacement:			seatbelts . . . . .	14-55d	14-95
Installation. . . . .	9-10b	9-16			
Removal . . . . .	9-10a	9-16			

INDEX (Contd)

	Para	Page		Para	Page
Removal of companion seatbelts	14-55c	14-94	Secondary heater fuel lines		
Installation of driver's seatbelts.	14-55b	14-94	replacement:		
Removal of driver's seatbelts. . .	14-55a	14-94	Installation . . . . .	14-35b	14-55
Seatbelt kit, floating, replacement:			Removal . . . . .	14-35a	14-55
Installation of companion			Second reduction drivechain		
seatbelts . . . . .	14-56d	14-97	maintenance (M764):		
Removal of companion seatbelts	14-56c	14-96	Adjustment . . . . .	13-15c	13-26
Installation of driver's seatbelts.	14-56b	14-96	Installation . . . . .	13-15b	13-26
Removal of driver's seatbelts. . .	14-56a	14-96	Removal . . . . .	13-15a	13-26
Seatbelt kits, troop seat mounting			Selector switch, converter,		
kit and, maintenance index . . . .	14-53	14-92	replacement:		
Seat, companion, maintenance:			Installation . . . . .	12-67b	12-108
Companion seat backrest			Removal . . . . .	12-67a	12-108
installation . . . . .	11-26h	11-43	Sending unit, engine temperature,		
Companion seat backrest			replacement:		
removal . . . . .	11-26a	11-42	Installation . . . . .	4-24b	4-39
Companion seat cushion			Removal . . . . .	4-24a	4-39
installation . . . . .	11-26g	11-43	Sending unit, fuel level,		
Companion seat cushion			replacement:		
removal . . . . .	11-26b	11-42	Installation . . . . .	4-26b	4-41
Companion seat installation . . .	11-26f	11-43	Removal . . . . .	4-26a	4-41
Companion seat removal . . . . .	11-26c	11-42	Sending unit, oil pressure,		
Frame assembly . . . . .	11-26e	11-42	replacement:		
Frame disassembly . . . . .	11-26d	11-42	Installation . . . . .	4-23b	4-38
Seat, driver's, replacement:			Removal . . . . .	4-23a	4-38
Installation . . . . .	11-28b	11-49	Separator element test valve, gage,		
Removal . . . . .	11-28a	11-49	and lines replacement (M49A2C):		
Seat frame, earth boring			Installation . . . . .	12-40b	12-60
machine, replacement:			Removal . . . . .	12-40a	12-60
Installation . . . . .	12-92b	12-154	Separator, filter, maintenance		
Removal . . . . .	12-92a	12-154	(M49A2C):		
Secondary and final fuel filters			Assembly . . . . .	12-41d	12-63
testing and maintenance:			Cleaning and inspection. . . . .	12-41c	12-63
Bleeding air . . . . .	3-29h	3-58	Disassembly . . . . .	12-41b	12-62
Cleaning and inspection. . . . .	3-29e	3-56	Installation . . . . .	12-41e	12-63
Draining . . . . .	3-29b	3-55	Removal . . . . .	12-41a	12-62
Fuel filter head, secondary, and			Separator-to-sump pipe, filter,		
final fuel filters installation. . .	3-29g	3-58	replacement:		
Fuel filter head, secondary, and			Installation . . . . .	12-28b	12-47
final fuel filters removal . . . . .	3-29c	3-56	Removal . . . . .	12-28a	12-47
Fuel filters installation. . . . .	3-29f	3-56	Servicing, battery and battery		
Fuel filters removal . . . . .	3-29d	3-56	box replacement:		
Testing fuel pressure . . . . .	3-29a	3-54	Batteries and battery box		
Secondary and primary heater			installation . . . . .	4-49e	4-78
switches replacement:			Batteries and battery box		
Installation . . . . .	14-33b	14-52	removal . . . . .	4-49a	4-76
Removal . . . . .	14-33a	14-52	Battery and battery box		
Secondary heater and duct			servicing . . . . .	4-49c	4-77
replacement:			Battery box support installation	4-49d	4-78
Duct installation . . . . .	14-36c	14-58	Battery box support removal. . .	4-49b	4-76
Duct removal . . . . .	14-36b	14-58			
Heater, exhaust tube, and guard					
installation . . . . .	14-36d	14-59			
Heater, exhaust tube, and guard					
removal . . . . .	14-36a	14-56			

## INDEX (Contd)

	Para	Page		Para	Page
Service and troubleshooting instructions sections I thru VII . . .		2-1	Shift linkage, transmission power takeoff (PTO), maintenance:		
Service brake adjustment. . . . .	8-8	8-22	Adjustment . . . . .	13-20c	13-34
Service brake bleeding:			Inspection . . . . .	13-20b	13-34
Manual method . . . . .	8-12b	8-34	Installation . . . . .	13-20d	13-35
Pressure tank method . . . . .	8-12a	8-32	Removal . . . . .	13-20a	13-34
Service brakeshoes maintenance:			Shipment and limited storage:		
Cleaning and inspection. . . . .	8-7b	8-20	Cleaning . . . . .	15-2	15-1
Installation . . . . .	8-7c	8-20	Inspection in limited storage. . .	15-11	15-3
Removal . . . . .	8-7a	8-19	Limited storage instructions . . .	15-10	15-3
Service upon receipt:			Loading and movement . . . . .	15-8	15-2
General . . . . .	2-4	2-1	Lubrication . . . . .	15-3	15-1
Servicing, cooling system:			Packaging . . . . .	15-5	15-2
Cleaning and flushing system. .	3-41b	3-94	Packing . . . . .	15-6	15-2
Draining system . . . . .	3-41a	3-94	Preservation . . . . .	15-4	15-2
Filling system . . . . .	3-41c	3-94	Removal from limited storage . .	15-12	15-3
Servicing instructions, general inspection and, . . . . .	2-5	2-1	Scope . . . . .	15-1	15-1
Setup procedures, STE/ICE tests and, . . . . .	2-19	2-148	Shipment of army documents . .	15-7	15-2
Shackle, front spring, replacement:			Shock absorber replacement:		
Installation . . . . .	7-14b	7-32	Installation . . . . .	7-20b	7-46
Removal . . . . .	7-14a	7-32	Removal . . . . .	7-20a	7-46
Shackle, rear, replacement:			Shutoff and coupling, primary heater fuel, replacement:		
Installation . . . . .	10-5b	10-6	Installation . . . . .	14-29b	14-44
Removal . . . . .	10-5a	10-6	Removal . . . . .	14-29a	14-44
Shackle, front, (w/o winch) replacement:			Shuttle (double check) valve replacement:		
Installation . . . . .	10-2b	10-2	Installation . . . . .	8-35b	8-84
Removal . . . . .	10-2a	10-2	Removal . . . . .	8-35a	8-84
Shackle, front, (w/winch) replacement:			Side marker and clearance lamps replacement:		
Installation . . . . .	10-3b	10-3	Installation . . . . .	4-45b	4-69
Removal . . . . .	10-3a	10-3	Removal . . . . .	4-45a	4-69
Shaft, pedal, support replacement:			Side panel replacement:		
Installation . . . . .	3-11b	3-19	Side panel hinges installation . .	11-11d	11-16
Removal . . . . .	3-11a	3-19	Side panel hinges removal . . . .	11-11b	11-16
Shaft, power divider propeller, replacement (M764):			Side panel installation . . . . .	11-11e	11-17
Inspection . . . . .	13-21b	13-36	Side panel removal . . . . .	11-11a	11-16
Installation . . . . .	13-21c	13-36	Thumb cranks installation . . . .	11-11f	11-17
Removal . . . . .	13-21a	13-36	Thumb cranks removal . . . . .	11-11c	11-16
Shaft, propeller, maintenance:			Side rail maintenance:		
Assembly . . . . .	7-2d	7-4	Cleaning . . . . .	12-82b	12-131
Cleaning and inspection. . . . .	7-2c	7-3	Installation . . . . .	12-82c	12-131
Disassembly . . . . .	7-2b	7-3	Removal . . . . .	12-82a	12-131
Installation . . . . .	7-2e	7-5	Slave receptacle replacement:		
Removal . . . . .	7-2a	7-2	Installation . . . . .	14-16b	14-24
Shaft support, pedal, replacement:			Removal . . . . .	14-16a	14-24
Installation . . . . .	3-11b	3-19	Sleeve, fuel tank filler cap and, replacement:		
Removal . . . . .	3-11a	3-19	Installation . . . . .	3-22b	3-32
			Removal . . . . .	3-22a	3-32
			Snatch sheave maintenance:		
			Assembly . . . . .	12-97c	12-162
			Disassembly . . . . .	12-97a	12-162
			Inspection . . . . .	12-97b	12-162

INDEX (Contd)

	Para	Page		Para	Page
Snatch sheave replacement:			Speedometer adapter removal. . .	4-16b	4-30
Installation . . . . .	12-98b	12-164	Speedometer shaft installation . .	4-16d	4-30
Removal . . . . .	12-98a	12-164	Speedometer shaft removal. . . .	4-16a	4-30
Solenoid, air horn, and bracket replacement:			Splash guard front, replacement (M35A2C, M36A2):		
Air horn installation . . . . .	4-31c	4-48	Installation. . . . .	12-6b	12-8
Air horn removal . . . . .	4-31b	4-48	Removal . . . . .	12-6a	12-8
Solenoid installation . . . . .	4-31d	4-48	Splash guard, rear, replacement:		
Solenoid removal. . . . .	4-31a	4-48	Installation. . . . .	12-109b	12-177
Dump body spare tire carrier maintenance:			Removal . . . . .	12-109a	12-177
Installation . . . . .	12-18b	12-27	Splash guard, rear, replacement:		
Removal . . . . .	12-18a	12-26	Lower splash guard installation . . . . .	12-58d	12-95
Spare tire carrier maintenance (all except M342A2):			Lower splash guard removal. . .	12-58a	12-95
Assembly . . . . .	10-7d	10-9	Upper splash guard installation . .	12-58c	12-95
Disassembly . . . . .	10-7b	10-8	Upper splash guard removal. . .	12-58b	12-95
Inspection . . . . .	10-7c	10-8	Spring, front, maintenance:		
Installation . . . . .	10-7e	10-9	Assembly . . . . .	7-16c	7-38
Removal . . . . .	10-7a	10-8	Cleaning and inspection. . . . .	7-16b	7-38
Special purpose bodies systems operation:			Disassembly . . . . .	7-16a	7-36
Dump body hydraulic system operation (M342A2) . . . . .	1-22a	1-64	Spring, front, replacement:		
Earth boring, polesetting, and rear winch systems operation (M764) . . . . .	1-22b	1-66	Installation . . . . .	7-13b	7-30
Fuel tank system operation (M49A2C) . . . . .	1-22e	1-70	Removal . . . . .	7-13a	7-28
Outrigger hydraulic system operation (M764). . . . .	1-22c	1-68	Spring, rear, maintenance:		
Rear winch and pipeline systems operation (M756A2) . . . . .	1-22f	1-72	Assembly . . . . .	7-18c	7-43
Water tank system operation (M50A2 and M50A3) . . . . .	1-22d	1-70	Cleaning and inspection. . . . .	7-18b	7-42
Special purpose kits maintenance.		14-1	Disassembly . . . . .	7-18a	7-42
Special tools, TMDE, and support equipment . . . . .	2-2	2-1	Spring, rear, replacement:		
Specific inspection and servicing instructions . . . . .	2-6	2-2	Installation . . . . .	7-17b	7-40
Specific PMCS procedure. . . . .	2-11	2-3	Removal . . . . .	7-17a	7-40
Speed control cable maintenance:			Spring seat, rear, replacement:		
Adjustment . . . . .	12-54d	12-89	Installation . . . . .	7-19b	7-44
Inspection . . . . .	12-54b	12-88	Removal . . . . .	7-19a	7-44
Installation . . . . .	12-54c	12-88	Spring shackle, front, replacement:		
Removal . . . . .	12-54a	12-88	Installation . . . . .	7-14b	7-32
Speedometer and tachometer replacement:			Removal . . . . .	7-14a	7-32
Installation . . . . .	4-13b	4-24	Spring wear pad, rear, replacement:		
Removal . . . . .	4-13a	4-24	Installation . . . . .	7-21b	7-48
Speedometer driveshaft and adapter replacement:			Removal . . . . .	7-21a	7-48
Speedometer adapter installation . . . . .	4-16c	4-30	Starter motor replacement:		
			Installation . . . . .	4-7b	4-12
			Removal . . . . .	4-7a	4-12
			Starter relay, magnetic, and mounting bracket replacement:		
			Installation . . . . .	4-6b	4-10
			Removal . . . . .	4-6a	4-10
			Starter switch replacement:		
			Installation . . . . .	4-8b	4-14
			Removal . . . . .	4-8a	4-14
			Starting system, table 2-4:		
			Electrical troubleshooting. . . . .		2-79

## INDEX (Contd)

	Para	Page		Para	Page
Static reel replacement (M49A2C):			Switch, accessory, replacement:		
Installation . . . . .	12-29b	12-48	Installation . . . . .	4-21b	4-36
Removal . . . . .	12-29a	12-48	Removal . . . . .	4-21a	4-36
Steering gear adjustment . . . . .	9-9	9-15	Switch, front-wheel drive lock-in, maintenance:		
Steering knuckle boot replacement:			Air valve and bracket		
Installation . . . . .	7-9b	7-22	installation . . . . .	6-4f	6-18
Removal . . . . .	7-9a	7-22	Air valve and bracket removal . . . . .	6-4a	6-12
Steering wheel replacement:			Cleaning and inspection . . . . .	6-4c	6-15
Installation . . . . .	9-12b	9-20	Line installation . . . . .	6-4e	6-16
Removal . . . . .	9-12a	9-20	Line removal . . . . .	6-4b	6-14
STE/ICE chain index . . . . .	2-17	2-148	Repair . . . . .	6-4d	6-16
STE/ICE description and operation	2-20	2-148	Switch, low air pressure, replacement:		
STE/ICE general . . . . .	2-16	2-148	Installation . . . . .	4-25b	4-40
STE/ICE tests and setup procedures . . . . .	2-19	2-148	Removal . . . . .	4-25a	4-40
STE/ICE, vehicle testing . . . . .	2-21	2-156	Switch, manifold heater, replacement:		
Step kit, bumper, replacement:			Installation . . . . .	4-22b	4-37
Installation . . . . .	14-48b	14-84	Removal . . . . .	4-22a	4-37
Removal . . . . .	14-48a	14-84	Switch, light, replacement:		
Step plate replacement:			Installation . . . . .	4-18b	4-33
Installation . . . . .	12-104b	12-171	Removal . . . . .	4-18a	4-33
Removal . . . . .	12-104a	12-171	Switch, starter, replacement:		
Stiff-leg jack replacement:			Installation . . . . .	4-8b	4-14
Installation . . . . .	12-103b	12-170	Removal . . . . .	4-8a	4-14
Removal . . . . .	12-103a	12-170	Switch, stoplight, replacement:		
Stop control cable, engine, maintenance:			Installation . . . . .	4-29b	4-45
Adjustment . . . . .	3-34c	3-76	Removal . . . . .	4-29a	4-45
Installation . . . . .	3-34b	3-76	System, exhaust, replacement:		
Removal . . . . .	3-34a	3-76	Installation . . . . .	3-37b	3-84
Stoplight air pressure switch replacement (M275A2):			Removal . . . . .	3-37a	3-82
Installation . . . . .	4-32b	4-50	System, exhaust, replacement (M50A2 and M50A3):		
Removal . . . . .	4-32a	4-50	Installation . . . . .	3-38b	3-88
Stoplight switch replacement:			Removal . . . . .	3-38a	3-86
Installation . . . . .	4-29b	4-45			
Removal . . . . .	4-29a	4-45	T		
Storage, limited, instructions:			Table 1-1, Model differences . . . . .	1-14	1-30
Inspection in limited storage . . . . .	15-11	15-3	Table 1-2, Equipment data . . . . .	1-15	1-31
Limited storage instructions . . . . .	15-10	15-3	Table 2-1, Preventive maintenance checks and services. . . . .		2-4
Removal from limited storage . . . . .	15-12	15-3	Table 2-2, Mechanical troubleshooting. . . . .		2-28
Scope . . . . .	15-9	15-2	Table 2-3, Compressed air and brake system troubleshooting . . . . .		2-54
Storage or shipment preparation . . . . .	1-4	1-1	Tachometer adapter replacement:		
Strainer, delivery pump, replacement:			Installation . . . . .	4-15b	4-28
Installation . . . . .	12-39b	12-59	Removal Installation . . . . .	4-15a	4-28
Removal . . . . .	12-39a	12-59	Tachometer, speedometer and, replacement:		
Supply hose, personnel heater, replacement:			Installation . . . . .	4-13b	4-24
Installation . . . . .	11-38b	11-75	Removal . . . . .	4-13a	4-24
Removal . . . . .	11-38a	11-75			



INDEX (Contd)

	Para	Page		Para	Page
Tachometer driveshaft and drive core maintenance:			Thermal barrier insulation replacement:		
Inspection . . . . .	4-14b	4-26	Installation . . . . .	14-10b	14-14
Installation . . . . .	4-14c	4-26	Removal . . . . .	14-10a	14-14
Removal . . . . .	4-14a	4-26	Thermostat, housing, and hose replacement:		
Tailgate, cargo bodies, maintenance:			Installation . . . . .	3-46c	3-104
Cleaning and inspection . . . . .	12-10a	12-15	Removal . . . . .	3-46a	3-104
Repair . . . . .	12-10b	12-15	Testing . . . . .	3-46b	3-104
Tailgate, cargo body, replacement (M35A2, M36A2):			Tie rod and tie rod end replacement:		
Installation . . . . .	12-3b	12-4	Installation . . . . .	9-10b	9-16
Removal . . . . .	12-3a	12-4	Removal . . . . .	9-10a	9-16
Tailgate, cargo body, replacement (M35A2C):			Tire, tube, and wheel maintenance:		
Installation . . . . .	12-4b	12-5	Inspection . . . . .	9-2c	9-3
Removal . . . . .	12-4a	12-5	Tire and tube installation . . . . .	9-2d	9-4
Tailgate, dump body, repair:			Tire and tube removal . . . . .	9-2b	9-2
Cleaning . . . . .	12-13a	12-18	Wheel installation . . . . .	9-2e	9-5
Inspection and repair . . . . .	12-13b	12-18	Wheel removal . . . . .	9-2a	9-1
Tailgate, pipeline construction, replacement:			Title block page . . . . .		i
Installation . . . . .	12-107b	12-176	TMDE, support equipment and special tools . . . . .	2-2	2-1
Removal . . . . .	12-107a	12-176	Toeboard, cab tunnel, rear tunnel, and, replacement:		
Tailgate, dump body, replacement:			Rear tunnel installation . . . . .	11-22e	11-36
Installation . . . . .	12-12b	12-17	Rear tunnel removal . . . . .	11-22b	11-36
Removal . . . . .	12-12a	12-17	Toeboard installation . . . . .	11-22d	11-36
Tank bodies front splash guard replacement:			Toeboard removal . . . . .	11-22c	11-36
Installation . . . . .	12-55b	12-90	Tunnel installation . . . . .	11-22f	11-36
Removal . . . . .	12-55a	12-90	Tunnel removal . . . . .	11-22a	11-36
Tank bodies upper and lower rear splash guard replacement:			Toe-in check and adjustment:		
Lower splash guard installation . . . . .	12-56d	12-92	Toe-in adjustment . . . . .	9-7b	9-13
Lower splash guard removal . . . . .	12-56a	12-92	Toe-in check . . . . .	9-7a	9-12
Upper splash guard installation . . . . .	12-56c	12-92	Toolbox, pipeline construction, maintenance:		
Upper splash guard removal . . . . .	12-56b	12-92	Assembly . . . . .	12-106c	12-174
Tank, fuel, replacement (M275A2):			Disassembly . . . . .	12-106a	12-174
Installation . . . . .	3-25b	3-40	Inspection . . . . .	12-106b	12-174
Removal . . . . .	3-25a	3-38	Toolbox replacement (M275A2):		
Tank, fuel, replacement:			Installation . . . . .	12-111b	12-180
Installation . . . . .	3-24b	3-36	Removal . . . . .	12-111a	12-180
Removal . . . . .	3-24a	3-34	Toolbox, dump body, maintenance (M342A2):		
Tank, hydraulic, replacement:			Assembly . . . . .	12-16c	12-22
Installation . . . . .	12-95b	12-158	Disassembly . . . . .	12-16b	12-22
Removal . . . . .	12-95a	12-158	Installation . . . . .	12-16d	12-22
Tees and tubes, fuel return, replacement:			Removal . . . . .	12-16a	12-22
Installation . . . . .	3-27b	3-49	Tool, van body, replacement:		
Removal . . . . .	3-27a	3-49	Compressor installation . . . . .	12-71j	12-116
Test equipment, electrical . . . . .	2-15	2-75	Compressor removal . . . . .	12-71a	12-114
Test meter (VTM), vehicle, troubleshooting . . . . .	2-18	2-148	Drill and stand installation . . . . .	12-71f	12-116
Testing, vehicle . . . . .	2-21	2-156	Drill and stand removal . . . . .	12-71e	12-114
Tests and setup procedures, STE/ICE . . . . .	2-19	2-148	Fire extinguisher bracket installation . . . . .	12-71h	12-116
			Fire extinguisher bracket removal . . . . .	12-71c	12-114

## INDEX (Contd)

	Para	Page		Para	Page
Grinding machine installation . . . . .	12-71g	12-116	Transmission gearshift lever knob and boot replacement:		
Grinding machine removal . . . . .	12-71d	12-114	Installation . . . . .	5-3b	5-3
Vice and machine swivel base installation . . . . .	12-71i	12-116	Removal . . . . .	5-3a	5-3
Vice and machine swivel base removal . . . . .	12-71b	12-114	Transmission power takeoff (PTO) shift linkage maintenance:		
Toolbox (under cab) replacement:			Adjustment . . . . .	13-20c	13-34
Installation . . . . .	11-19b	11-29	Inspection . . . . .	13-20b	13-34
Removal . . . . .	11-19a	11-29	Installation . . . . .	13-20d	13-35
Torque limits, appendix D:			Removal . . . . .	13-20a	13-34
General . . . . .	D-1	D-1	Troop seat, cargo body rack and, replacement:		
How to use torque table . . . . .	D-3	D-1	Cargo rack assembly . . . . .	12-2f	12-2
Torque limits . . . . .	D-2	D-1	Cargo rack disassembly . . . . .	12-2b	12-2
Torque rods replacement:			Inspection . . . . .	12-2d	12-2
Installation . . . . .	7-22b	7-52	Troop seat assembly . . . . .	12-2e	12-2
Removal . . . . .	7-22a	7-50	Troop seat disassembly . . . . .	12-2c	12-2
Trailer brake hose mast replacement:			Troop seat installation . . . . .	12-2g	12-2
Installation . . . . .	8-37b	8-88	Troop seat removal . . . . .	12-2a	12-2
Removal . . . . .	8-37a	8-88	Troop seat center mounted kit replacement:		
Trailer connection system, table 2-4: electrical troubleshooting . . . . .		2-146	Installation . . . . .	14-54b	14-93
Trailer protection valve replacement:			Removal . . . . .	14-54a	14-92
Installation . . . . .	8-36b	8-86	Troubleshooting compressed air and brake system:		
Removal . . . . .	8-36a	8-86	General . . . . .	2-13	2-52
Transfer case breather maintenance:			Troubleshooting electrical systems:		
Cleaning . . . . .	6-5b	6-20	General . . . . .	2-14	2-74
Installation . . . . .	6-5c	6-20	Troubleshooting, mechanical systems:		
Removal . . . . .	6-5a	6-20	General . . . . .	2-12	2-24
Transfer case controls and linkage (w/o PTO) maintenance:			Troubleshooting symptom index: Table 2-3 compressed air and brake system troubleshooting . . . . .		2-52
Cleaning and inspection . . . . .	6-3b	6-10	Troubleshooting, vehicle test meter (VTM) . . . . .	2-18	2-148
Installation . . . . .	6-3c	6-10	Tube, air cleaner indicator and, maintenance:		
Removal . . . . .	6-3a	6-10	Inspection and cleaning . . . . .	3-16c	3-26
Transfer case controls and linkage (w/PTO) maintenance :			Installation . . . . .	3-16d	3-26
Cleaning and inspection . . . . .	6-2b	6-4	Removal . . . . .	3-16b	3-26
Installation . . . . .	6-2c	6-4	Testing . . . . .	3-16a	3-25
PTO lock adjustment . . . . .	6-2d	6-8	Tubes, fuel return tees and, replacement:		
Removal . . . . .	6-2a	6-1	Installation . . . . .	3-27b	3-49
Transmission breather maintenance:			Removal . . . . .	3-27a	3-49
Cleaning . . . . .	5-2b	5-2	Tube, exhaust, replacement:		
Installation . . . . .	5-2c	5-2	Installation . . . . .	14-6b	14-8
Removal . . . . .	5-2a	5-2	Removal . . . . .	14-6a	14-8
Transmission gearshift and transfer case lever cover replacement:			Tubes, overturn, replacement (M49A2C):		
Installation . . . . .	14-12b	14-17	Installation . . . . .	12-26b	12-45
Removal . . . . .	14-12a	14-17	Removal . . . . .	12-26a	12-45
Transmission gearshift lever replacement:					
Installation . . . . .	5-4b	5-4			
Removal . . . . .	5-4a	5-4			

INDEX (Contd)

	Para	Page		Para	Page
Turbocharger oil drain tube, hose, and adapter replacement:			Upper hose installation . . . . .	3-43c	3-100
Installation . . . . .	3-19b	3-30	Upper hose removal. . . . .	3-43a	3-100
Removal . . . . .	3-19a	3-30	Upper and lower rear splash guard, tank bodies, replacement:		
Turbocharger oil inlet tube and adapter replacement:			Lower splash guard installation	12-56d	12-93
Installation . . . . .	3-18b	3-28	Lower splash guard removal. . .	12-56a	12-92
Removal . . . . .	3-18a	3-28	Upper splash guard installation	12-56c	12-92
Turn signal control and indicator lamp replacement:			Upper splash guard removal. . .	12-56b	12-92
Installation . . . . .	4-19b	4-34			
Removal . . . . .	4-19a	4-34	<b>V</b>		
Turn signal flasher replacement:			Valve, airbrake, replacement:		
Installation . . . . .	4-20b	4-35	Installation . . . . .	8-22b	8-50
Removal . . . . .	4-20a	4-35	Removal . . . . .	8-22a	8-50
Turn signal, intermediate, replacement:			Valve control levers, discharge, maintenance (M49A2C):		
Installation . . . . .	4-40b	4-61	Assembly . . . . .	12-21d	12-35
Removal . . . . .	4-40a	4-61	Cleaning and inspection. . . . .	12-21c	12-34
24-Volt circuit breaker replacement:			Disassembly . . . . .	12-21b	12-33
Installation . . . . .	12-65b	12-105	Installation . . . . .	12-21e	12-36
Removal . . . . .	12-65a	12-105	Removal . . . . .	12-21a	12-32
<b>U</b>			Valve, control, replacement:		
(Under cab) toolbox replacement:			Installation . . . . .	14-39b	14-62
Installation . . . . .	11-19b	11-29	Removal . . . . .	14-39a	14-62
Removal . . . . .	11-19a	11-29	Valve, discharge, replacement (M49A2C):		
Universal joint, front axle shaft and maintenance:			Installation . . . . .	12-20b	12-31
Cleaning and inspection. . . . .	7-6b	7-17	Removal . . . . .	12-20a	12-30
Installation . . . . .	7-6c	7-18	Valve, shuttle (doublecheck), replacement:		
Removal . . . . .	7-6a	7-16	Installation . . . . .	8-35b	8-84
Universal joint, hydraulic pump, maintenance:			Removal . . . . .	8-35a	8-84
Assembly . . . . .	12-90d	12-146	Valve, gate, replacement:		
Cleaning and inspection. . . . .	12-90c	12-146	Installation . . . . .	12-38b	12-58
Disassembly . . . . .	12-90b	12-146	Removal . . . . .	12-38a	12-58
Installation . . . . .	12-90e	12-147	Valve, globe, replacement (M49A2C):		
Removal . . . . .	12-90a	12-146	Installation. . . . .	12-27b	12-46
Universal joint maintenance:			Removal . . . . .	12-27a	12-46
Assembly . . . . .	7-4c	7-12	Valve, regulator, replacement:		
Cleaning and inspection. . . . .	7-4b	7-12	Installation. . . . .	14-40b	14-64
Disassembly . . . . .	7-4a	7-10	Removal . . . . .	14-40a	14-64
Upper and lower rear splash guard, cargo body, replacement (M35A2C):			Van bodies front splash guard replacement:		
Lower splash guard installation	12-5d	12-6	Installation. . . . .	12-70b	12-113
Lower splash guard removal. . .	12-5a	12-6	Removal . . . . .	12-70a	12-113
Upper splash guard installation	12-5c	12-6	Van body tool replacement:		
Upper splash guard removal. . .	12-5b	12-6	Compressor installation . . . . .	12-71j	12-116
Upper and lower radiator hose replacement:			Compressor removal . . . . .	12-71a	12-114
Lower hose installation . . . . .	3-43d	3-100	Drill and stand installation. . . .	12-71f	12-116
Lower hose removal. . . . .	3-43b	3-100	Drill and stand removal . . . . .	12-71e	12-114
			Fire extinguisher bracket installation . . . . .	12-71h	12-116
			Fire extinguisher bracket removal . . . . .	12-71c	12-114
			Grinding machine installation. . .	12-71g	12-116
			Grinding machine removal . . . .	12-71d	12-114

INDEX (Contd)

	Para	Page		Para	Page
Vice and machine swivel base installation . . . . .	12-71i	12-116	Water tank discharge tube and valve replacement (M50A2):		
Vice and machine swivel base removal . . . . .	12-71b	12-114	Discharge tube installation . . . . .	12-45d	12-68
Van door repair:			Discharge tube removal . . . . .	12-45a	12-68
Cleaning and inspection. . . . .	12-64c	12-102	Discharge valve installation . . . . .	12-45c	12-68
Left van door assembly. . . . .	12-64e	12-104	Discharge valve removal. . . . .	12-45b	12-68
Left van door disassembly . . . . .	12-64a	12-102	Water tank discharge tube and valve replacement (M50A3):		
Right van door assembly . . . . .	12-64d	12-104	Discharge tube cover installation . . . . .	12-46f	12-71
Right van door disassembly . . . . .	12-64b	12-102	Discharge tube cover removal . . . . .	12-46a	12-70
Van door replacement:			Discharge tube installation . . . . .	12-46e	12-70
Installation. . . . .	12-62b	12-100	Discharge tube removal . . . . .	12-46b	12-70
Removal . . . . .	12-62a	12-100	Discharge valves installation. . . . .	12-46d	12-70
Van door seals maintenance:			Discharge valves removal . . . . .	12-46c	12-70
Cleaning . . . . .	12-63b	12-101	Water tank discharge valve control levers maintenance (M50A2, M50A3):		
Installation. . . . .	12-63c	12-101	Adjustment . . . . .	12-47f	12-76
Removal . . . . .	12-63a	12-101	Assembly . . . . .	12-47d	12-74
Vehicle boarding ladder replacement:			Cleaning and inspection . . . . .	12-47c	12-74
Installation. . . . .	12-66b	12-106	Disassembly . . . . .	12-47b	12-73
Removal . . . . .	12-66a	12-106	Installation. . . . .	12-47e	12-76
Vehicle testing . . . . .	2-21	2-156	Removal . . . . .	12-47a	12-72
Vehicle test meter (VTM) troubleshooting. . . . .	2-18	2-148	Water tank filler cover replacement (M50A2):		
Vent, cab cowl, replacement:			Installation. . . . .	12-42b	12-64
Installation. . . . .	11-17b	11-26	Removal . . . . .	12-42a	12-64
Removal . . . . .	11-17a	11-26	Water tank filler cover replacement (M50A3):		
Vertical leveling worm drivechain replacement:			Installation. . . . .	12-43b	12-65
Installation. . . . .	12-86b	12-138	Removal . . . . .	12-43a	12-65
Removal . . . . .	12-86a	12-138	Water tank manhole cover replacement (M50A3):		
<b>W</b>					
Warnings, cautions, and data plates, location and contents . . . . .	1-13	1-14	Installation. . . . .	12-48b	12-79
Warranty information . . . . .	1-7	1-2	Removal . . . . .	12-48a	12-78
Water can bracket and running board replacement:			Wear pad, rear spring, replacement:		
Running board installation. . . . .	11-24c	1-40	Installation. . . . .	7-21b	7-48
Running board removal . . . . .	11-24b	11-40	Removal . . . . .	7-21a	7-48
Water can bracket installation . . . . .	11-24d	11-40	Weatherseal, cab door glass and, replacement:		
Water can bracket removal . . . . .	11-24a	11-40	Cab door glass adjustment . . . . .	11-5c	11-6
Water manifold and hose replacement:			Installation. . . . .	11-5b	11-6
Installation. . . . .	3-45b	3-103	Removal . . . . .	11-5a	11-6
Removal . . . . .	3-45a	3-103	Weatherseals, cab door, replacement:		
Water pump housing and water pump replacement:			Cab door head weatherseal installation . . . . .	11-10e	11-14
Water pump housing installation . . . . .	3-47d	3-106	Cab door head weatherseal removal . . . . .	11-10b	11-14
Water pump housing removal . . . . .	3-47a	3-106	Cab door pillar posts weatherseals installation . . . . .	11-10d	11-14
Water pump installation. . . . .	3-47c	3-106	Cab door pillar posts weatherseals removal . . . . .	11-10c	11-14
Water pump removal . . . . .	3-47b	3-106	Cab door weatherseals installation . . . . .	11-10f	11-15
Water pump manifold replacement (M50A2, M50A3):			Cab door weatherseals removal . . . . .	11-10a	11-14
Installation . . . . .	12-34b	12-53			
Removal . . . . .	12-34a	12-53			

INDEX (Contd)

	Para	Page		Para	Page
Wheel bearing adjustment . . . . .	9-5	9-11	Windshield washer pump installation . . . . .	11-35e	11-70
Wheel cylinder, hydraulic, replacement:			Windshield washer pump removal . . . . .	11-35d	11-70
Installation . . . . .	8-9b	8-24	Windshield washer reservoir installation . . . . .	11-35h	11-71
Removal . . . . .	8-9a	8-24	Windshield washer reservoir removal . . . . .	11-35a	11-70
Wheel, fifth, replacement:			Windshield washer tubing installation . . . . .	11-35g	11-71
Installation . . . . .	12-112b	12-181	Windshield washer tubing removal . . . . .	11-35b	11-70
Removal . . . . .	12-112a	12-181	Windshield wiper blade, arm, and motor replacement:		
Wheel, steering, replacement:			Windshield wiper arm installation . . . . .	11-34e	11-68
Installation . . . . .	9-12b	9-20	Windshield wiper arm removal .	11-34b	11-68
Removal . . . . .	9-12a	9-20	Windshield wiper blade installation . . . . .	11-34f	11-68
Wheel, tire, and tube maintenance:			Windshield wiper blade removal	11-34a	11-68
Inspection . . . . .	9-2c	9-3	Windshield wiper motor installation . . . . .	11-34d	11-68
Tire and tube installation . . . . .	9-2d	9-4	Windshield wiper motor removal . . . . .	11-34c	11-68
Tire and tube removal . . . . .	9-2b	9-2	Windshield wiper motor air tubes replacement:		
Wheel installation . . . . .	9-2e	9-5	Installation . . . . .	11-33b	11-67
Wheel removal . . . . .	9-2a	9-1	Removal . . . . .	11-33a	11-67
Winch cable, rear, replacement (M764):			Windshield wiper motor control valve replacement:		
Inspection . . . . .	13-10b	13-17	Installation . . . . .	8-19b	8-46
Installation . . . . .	13-10c	13-17	Removal . . . . .	8-19a	8-46
Removal . . . . .	13-10a	13-17	Wiring diagram, schematic and, Appendix E . . . . .		E-1
Winch drum lock replacement (M756A2):			Wiring harness, cab protector, replacement (M756A2):		
Inspection . . . . .	13-7b	13-13	Installation . . . . .	4-52b	4-82
Installation . . . . .	13-7c	13-13	Removal . . . . .	4-52a	4-82
Removal . . . . .	13-7a	13-13	Wiring harness connector repair:		
Winch, rear, replacement (M756A2):			Connector assembly repair . . . .	4-51d	4-80
Installation . . . . .	13-18b	13-32	Female cable connector repair. .	4-51c	4-80
Removal . . . . .	13-18a	13-30	Male cable connector repair . . .	4-51b	4-80
Winch, front, replacement:			Receptacle assembly repair. . . .	4-51e	4-81
Installation . . . . .	13-5b	13-8	Terminal-type cable connector repair . . . . .	4-51a	4-79
Removal . . . . .	13-5a	13-8	Worm drivechain, vertical leveling, replacement:		
Windshield arm, glass, and handle replacement:			Installation . . . . .	12-86b	12-138
Arm installation . . . . .	11-21f	11-35	Removal . . . . .	12-86a	12-138
Arm removal . . . . .	11-21a	11-34			
Glass installation . . . . .	11-21e	11-35			
Glass removal . . . . .	11-21b	11-34			
Handle installation . . . . .	11-21d	11-34			
Handle removal . . . . .	11-21c	11-34			
Windshield assembly maintenance:					
Assembly . . . . .	11-20c	11-32			
Disassembly . . . . .	11-20b	11-30			
Installation . . . . .	11-20d	11-32			
Removal . . . . .	11-20a	11-30			
Windshield washer reservoir, tubing, jet, and pump replacement:					
Windshield washer jet installation . . . . .	11-35f	11-70			
Windshield washer jet removal .	11-35c	11-70			

By Order of the Secretary of the Army:

**GORDON R. SULLIVAN**  
*Brigadier General, United States Army*  
*Chief of Staff*

Official:

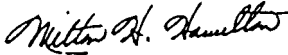
  
**MILTON H. HAMILTON**  
*Administrative Assistant to the*  
*Secretary of the Army*  
00046

By Order of the Secretary of the Air Force:

**MERRILL A. McPEAK**  
*General, United States Air Force*  
*Chief of Staff*

**CHARLES C. MCDONALD**  
*General, United States Air Force*  
*Commander, Air Force Logistics Command*

Distribution:

To be distributed in accordance with DA Form 12-38-E (Block No.0417) Unit maintenance requirements for TM9-2320-361-20.



RECOMMENDED CHANGES TO EQUIPMENT TECHNICAL PUBLICATIONS



THEN... JOT DOWN THE DOPE ABOUT IT ON THIS FORM. CAREFULLY TEAR IT OUT, FOLD IT AND DROP IT IN THE MAIL!

SOMETHING WRONG WITH THIS PUBLICATION?

FROM: (PRINT YOUR UNIT'S COMPLETE ADDRESS)

Your Mailing Address

DATE SENT

Day you fill out form

PUBLICATION NUMBER

TM 9-2320-361-20

PUBLICATION DATE

Date of TM

PUBLICATION TITLE

UNIT MAINTENANCE FOR 2 1/2-TON, M44A2 SERIES TRUCKS (MULTIFUEL)

BE EXACT... PIN-POINT WHERE IT IS

PAGE NO	PARA-GRAPH	FIGURE NO	TABLE NO
3-50	3-28		
8-70	8-29		

IN THIS SPACE TELL WHAT IS WRONG AND WHAT SHOULD BE DONE ABOUT IT:

Step 2 reads: Close draincock (i).  
 Should read: Close draincock (ii).  
 Equipment condition reads: Parking Brake set  
 • Hood raised and secured  
 Should read: • Parking Brake set  
 • Hood raised and secured  
 • Air reservoirs drained

SAMPLE

PRINTED NAME, GRADE OR TITLE, AND TELEPHONE NUMBER

YOUR NAME, RANK, and PHONE

SIGN HERE:

PFC John A. Doe



FILL IN YOUR  
UNIT'S ADDRESS

FOLD BACK

DEPARTMENT OF THE ARMY

Your MAILING-  
Address

SAMPLE

Commander  
US Army Tank-Automotive Command  
ATTN: AMSTA-MB  
Warren, Michigan 48397-5000

TEAR ALONG PERFORATED LINE

RECOMMENDED CHANGES TO EQUIPMENT TECHNICAL PUBLICATIONS



THEN... JOT DOWN THE DOPE ABOUT IT ON THIS FORM. CAREFULLY TEAR IT OUT. FOLD IT AND DROP IT IN THE MAIL!

**SOMETHING WRONG WITH THIS PUBLICATION?**

FROM: (PRINT YOUR UNIT'S COMPLETE ADDRESS)

DATE SENT

PUBLICATION NUMBER

TM 9-2320-361-20

PUBLICATION DATE

25 Oct 91

PUBLICATION TITLE

UNIT MAINTENANCE FOR 2 1/2-TON, M44A2 SERIES TRUCKS (MULTIFUEL)

BE EXACT... PIN-POINT WHERE IT IS

PAGE NO

PARA-GRAPH

FIGURE NO

TABLE NO

IN THIS SPACE TELL WHAT IS WRONG AND WHAT SHOULD BE DONE ABOUT IT:

PRINTED NAME, GRADE OR TITLE, AND TELEPHONE NUMBER

SIGN HERE

FILL IN YOUR  
UNIT'S ADDRESS



FOLD BACK

DEPARTMENT OF THE ARMY

---

---

TEAR ALONG PERFORATED LINE

Commander  
US Army Tank-Automotive Command  
ATTN: AMSTA-MB  
Warren, Michigan 48397-5000

RECOMMENDED CHANGES TO EQUIPMENT TECHNICAL PUBLICATIONS



THEN... JOT DOWN THE DOPE ABOUT IT ON THIS FORM. CAREFULLY TEAR IT OUT. FOLD IT AND DROP IT IN THE MAIL!

**SOMETHING WRONG WITH THIS PUBLICATION?**

FROM: (PRINT YOUR UNIT'S COMPLETE ADDRESS)

DATE SENT

PUBLICATION NUMBER

**TM 9-2320-361-20**

PUBLICATION DATE

25 Oct 91

PUBLICATION TITLE

UNIT MAINTENANCE FOR 2 1/2-TON, M44A2 SERIES TRUCKS (MULTIFUEL)

BE EXACT... PIN-POINT WHERE IT IS

PAGE NO	PARA-GRAPH	FIGURE NO	TABLE NO

IN THIS SPACE TELL WHAT IS WRONG AND WHAT SHOULD BE DONE ABOUT IT:

PRINTED NAME, GRADE OR TITLE, AND TELEPHONE NUMBER

SIGN HERE

FILL IN YOUR  
UNIT'S ADDRESS



FOLD BACK

DEPARTMENT OF THE ARMY

---

---

TEAR ALONG PERFORATED LINE

Commander  
US Army Tank-Automotive Command  
ATTN: AMSTA-MB  
Warren, Michigan 48397-5000

RECOMMENDED CHANGES TO EQUIPMENT TECHNICAL PUBLICATIONS



THEN... JOT DOWN THE DOPE ABOUT IT ON THIS FORM. CAREFULLY TEAR IT OUT. FOLD IT AND DROP IT IN THE MAIL!

**SOMETHING WRONG WITH THIS PUBLICATION?**

FROM: (PRINT YOUR UNIT'S COMPLETE ADDRESS)

DATE SENT

PUBLICATION NUMBER

TM 9-2320-361-20

PUBLICATION DATE

25 Oct 91

PUBLICATION TITLE

UNIT MAINTENANCE FOR 2 1/2-TON, M44A2 SERIES TRUCKS (MULTIFUEL)

BE EXACT. PIN-POINT WHERE IT IS

PAGE NO	PARA-GRAPH	FIGURE NO	TABLE NO
---------	------------	-----------	----------

IN THIS SPACE TELL WHAT IS WRONG AND WHAT SHOULD BE DONE ABOUT IT:

PRINTED NAME, GRADE OR TITLE, AND TELEPHONE NUMBER

SIGN HERE

FILL IN YOUR  
UNIT'S ADDRESS

FOLD BACK

DEPARTMENT OF THE ARMY

---

---

TEAR ALONG PERFORATED LINE

Commander  
US Army Tank-Automotive Command  
ATTN: AMSTA-MB  
Warren, Michigan 48397-5000

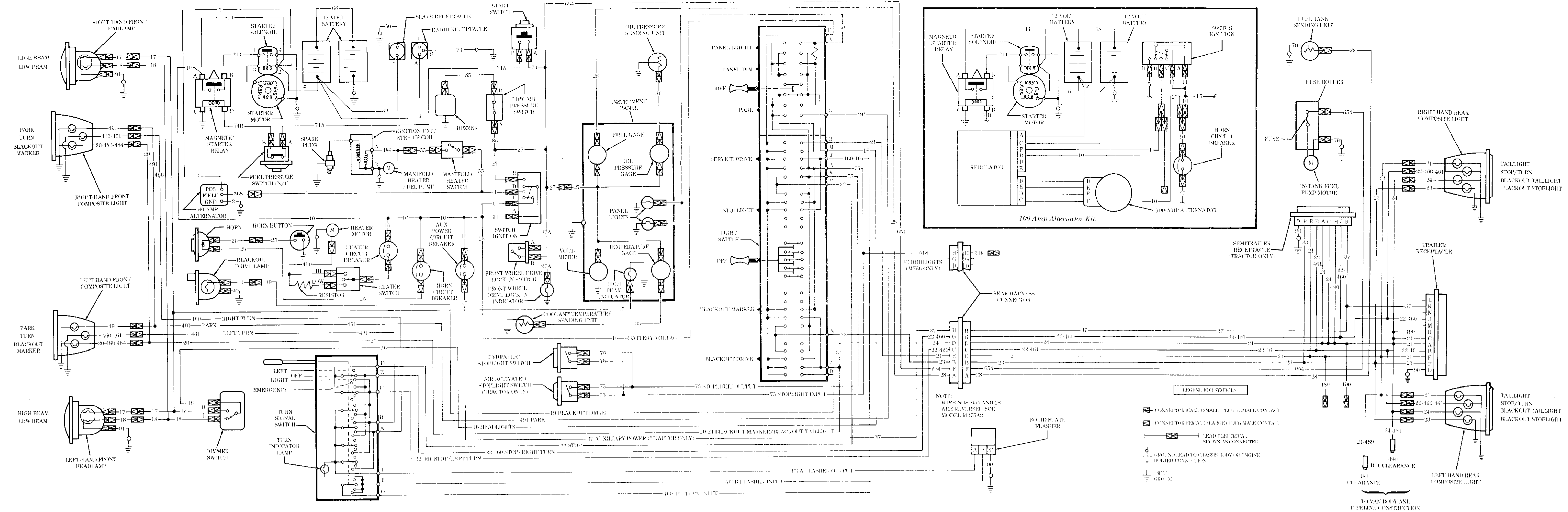

Foldout 1 - Electrical System Wiring Diagram



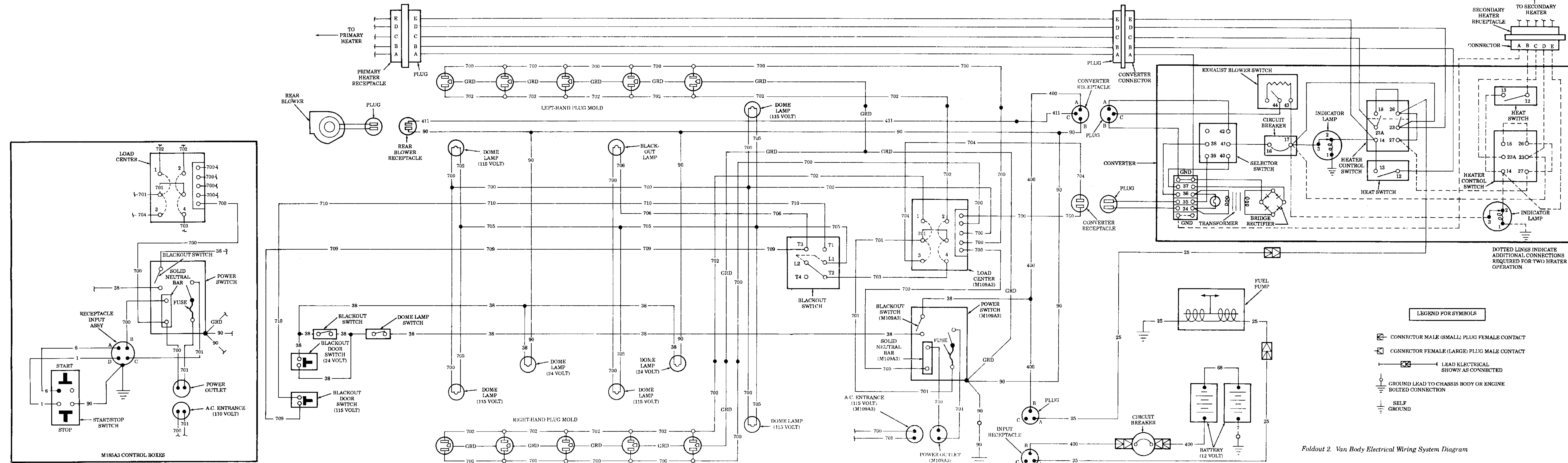

Foldout 2. Van Body Electrical Wiring System Diagram

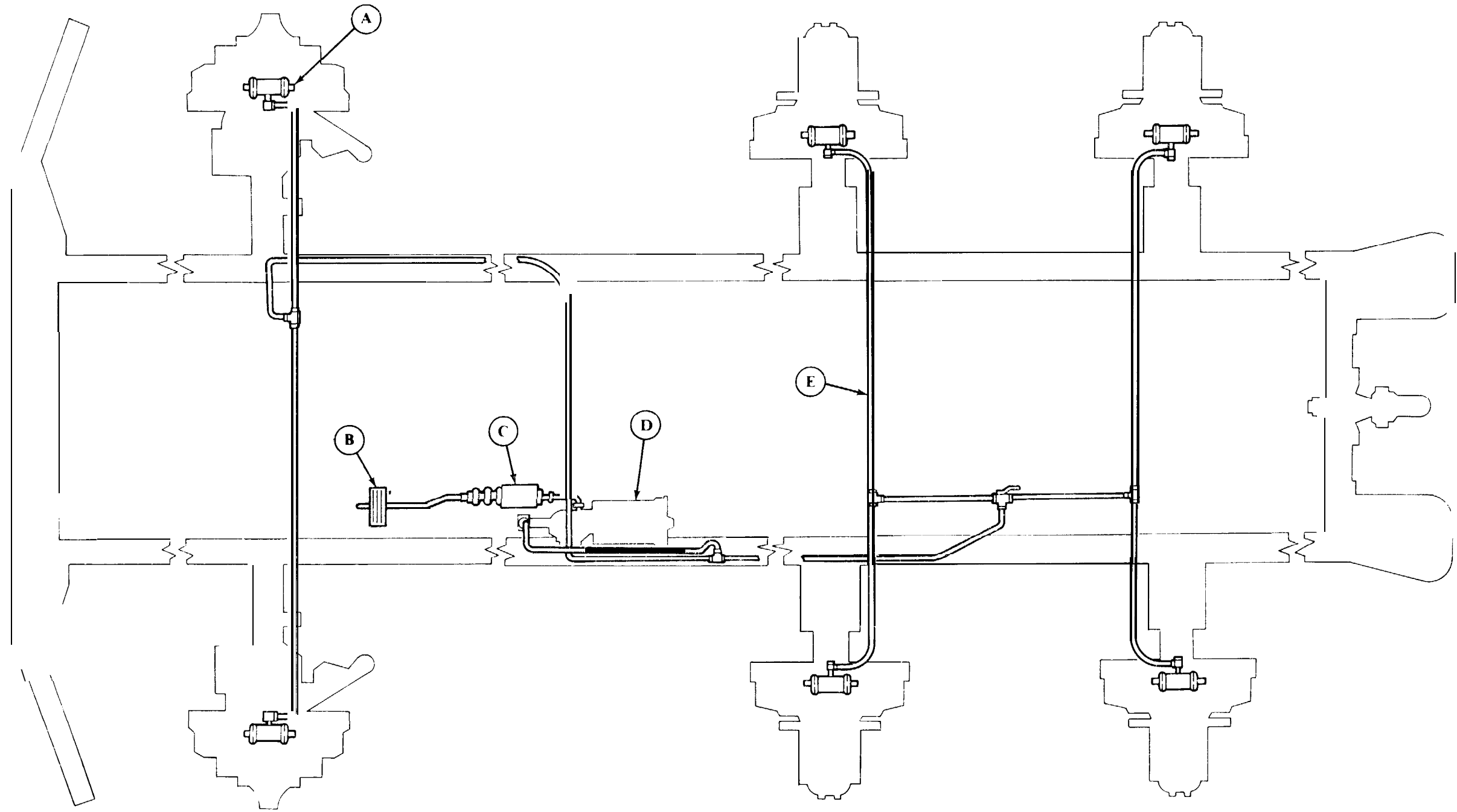

- (A) WHEEL CYLINDER
- (B) BRAKE PEDAL
- (C) AIR-HYDRAULIC CYLINDER
- (D) MASTER CYLINDER
- (E) BRAKE LINE

*Foldout 3. Hydraulic Brake System Diagram*

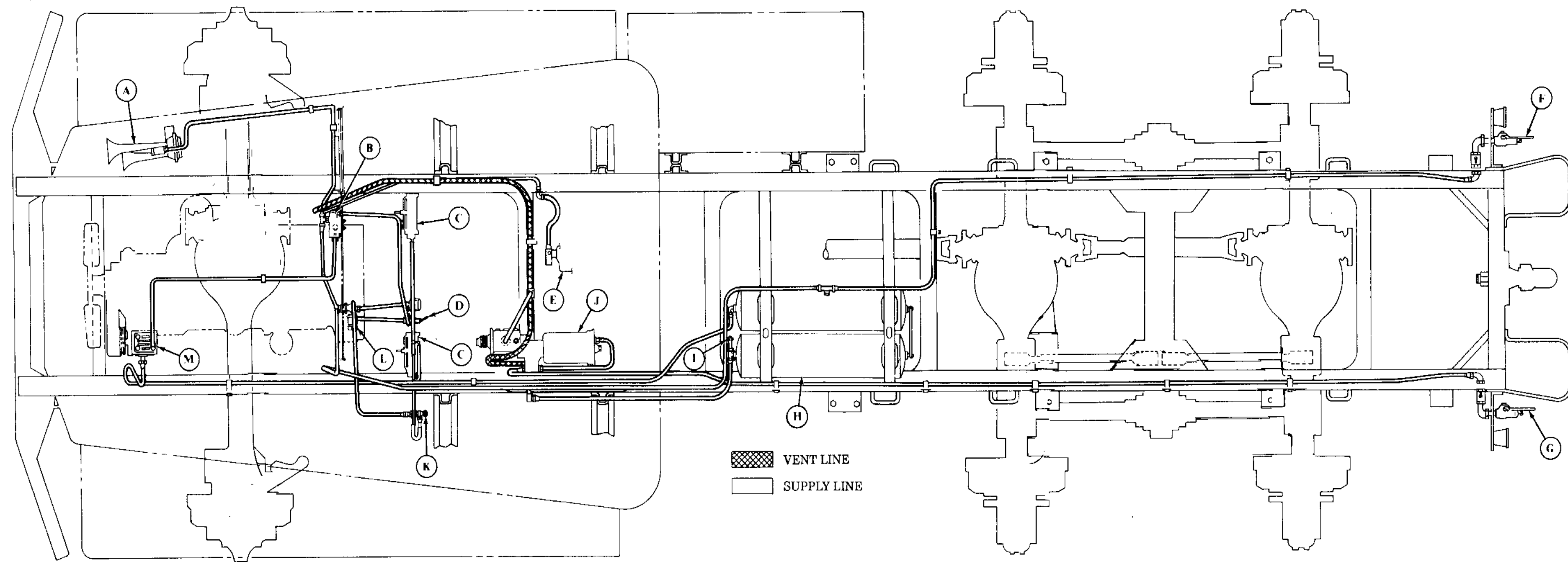

- |                                  |  |                            |                                     |
|----------------------------------|--|----------------------------|-------------------------------------|
| (A) AIR HORN                     | (E) FRONT AXLE ENGAGEMENT AIR CYLINDER | (H) AIR RESERVOIRS         | (K) WINDSHIELD WIPER SWITCH         |
| (B) GOVERNOR                     | (F) REAR EMERGENCY AIR COUPLING        | (I) SAFETY VALVE           | (L) LOW AIR PRESSURE WARNING SWITCH |
| (C) WINDSHIELD WIPER MOTORS      | (G) REAR SERVICE AIR COUPLING          | (J) AIR-HYDRAULIC CYLINDER | (M) AIR COMPRESSOR                  |
| (D) FRONT AXLE ENGAGEMENT SWITCH |  |                            |                                     |

Foldout 4. Compressed Air System - All Except M342A2, M764, M275A2

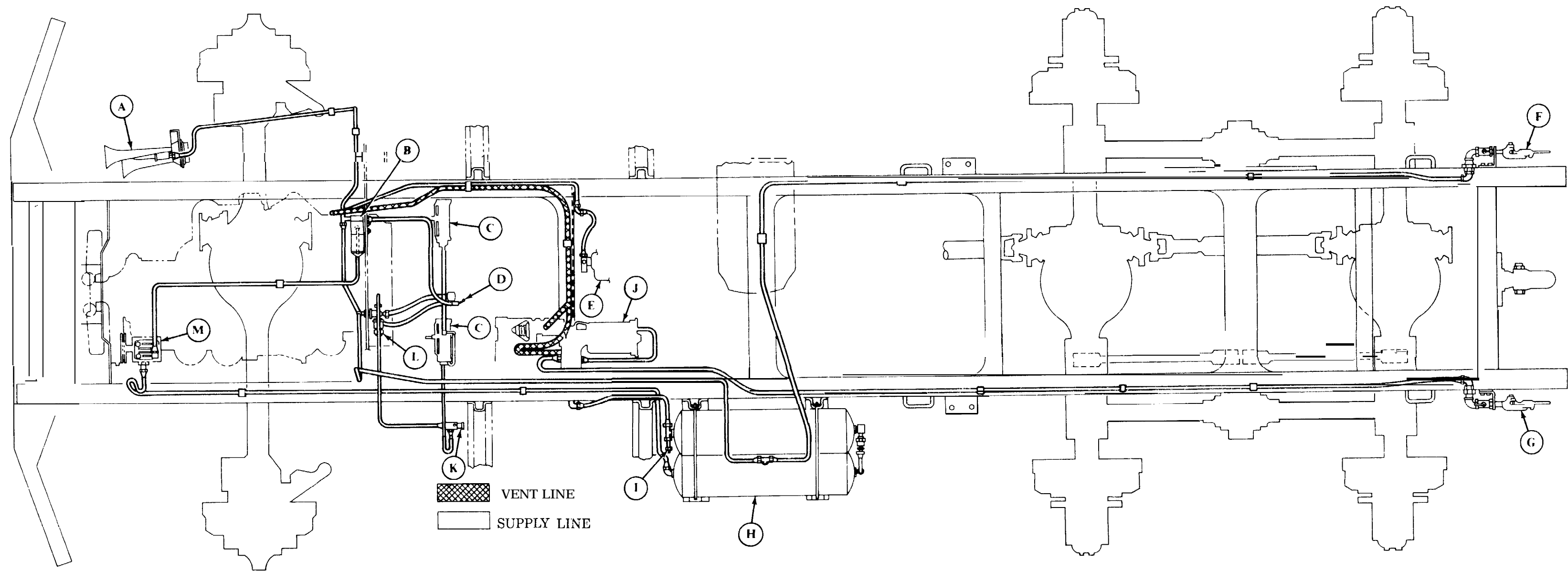

- |   |   |                                   |  |
|---|---|-----------------------------------|--|
| ○ <b>A</b> AIR HORN                     | ○ <b>E</b> FRONT AXLE ENGAGEMENT AIR CYLINDER | ○ <b>H</b> AIR RESERVOIRS         | ○ <b>K</b> WINDSHIELD WIPER SWITCH         |
| ○ <b>B</b> GOVERNOR                     | ○ <b>F</b> REAR EMERGENCY AIR COUPLING        | ○ <b>I</b> SAFETY VALVE           | ○ <b>L</b> LOW AIR PRESSURE WARNING SWITCH |
| ○ <b>C</b> WINDSHIELD WIPER MOTORS      | ○ <b>G</b> REAR SERVICE AIR COUPLING          | ○ <b>J</b> AIR-HYDRAULIC CYLINDER | ○ <b>M</b> AIR COMPRESSOR                  |
| ○ <b>D</b> FRONT AXLE ENGAGEMENT SWITCH |   |                                   |  |

Foldout 5. Compressed Air System - M342A2

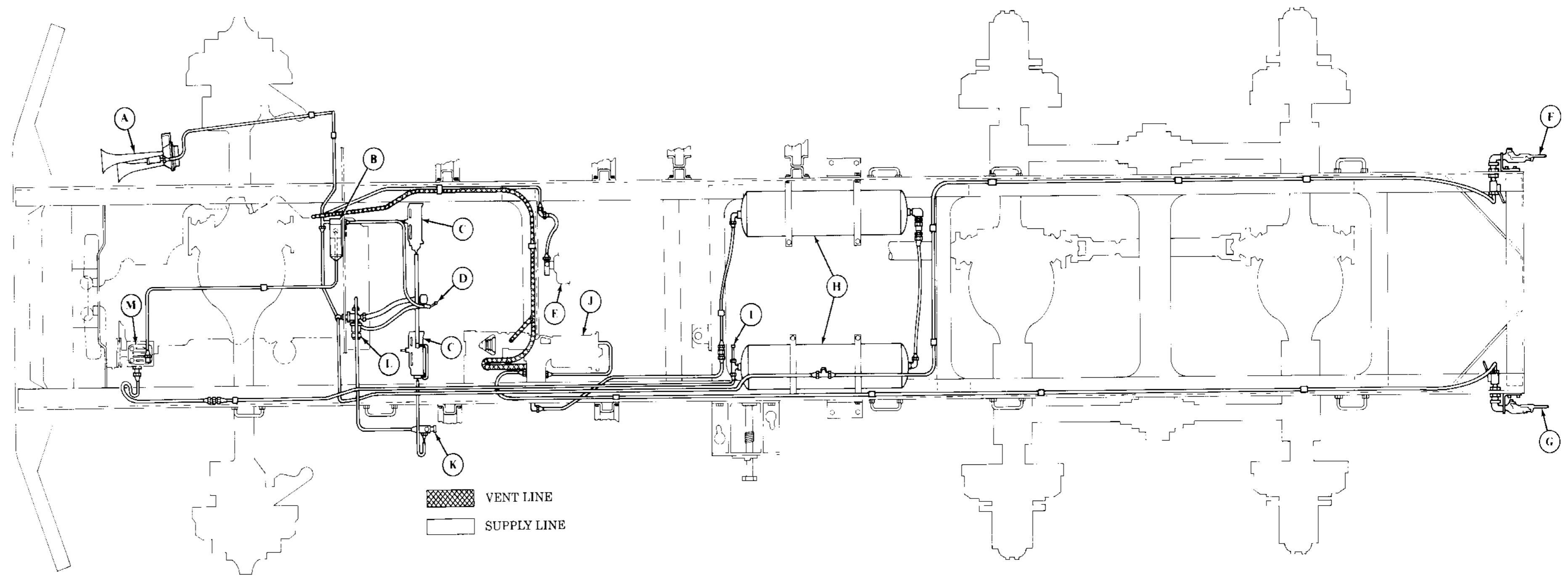

- |                                  |  |                            |                                     |
|----------------------------------|--|----------------------------|-------------------------------------|
| (A) AIR HORN                     | (E) FRONT AXLE ENGAGEMENT AIR CYLINDER | (H) AIR RESERVOIRS         | (K) WINDSHIELD WIPER SWITCH         |
| (B) GOVERNOR                     | (F) REAR EMERGENCY AIR COUPLING        | (I) SAFETY VALVE           | (L) LOW AIR PRESSURE WARNING SWITCH |
| (C) WINDSHIELD WIPER MOTORS      | (G) REAR SERVICE AIR COUPLING          | (J) AIR-HYDRAULIC CYLINDER | (M) AIR COMPRESSOR                  |
| (D) FRONT AXLE ENGAGEMENT SWITCH |  |                            |                                     |

Foldout 6. Compressed Air System - M764

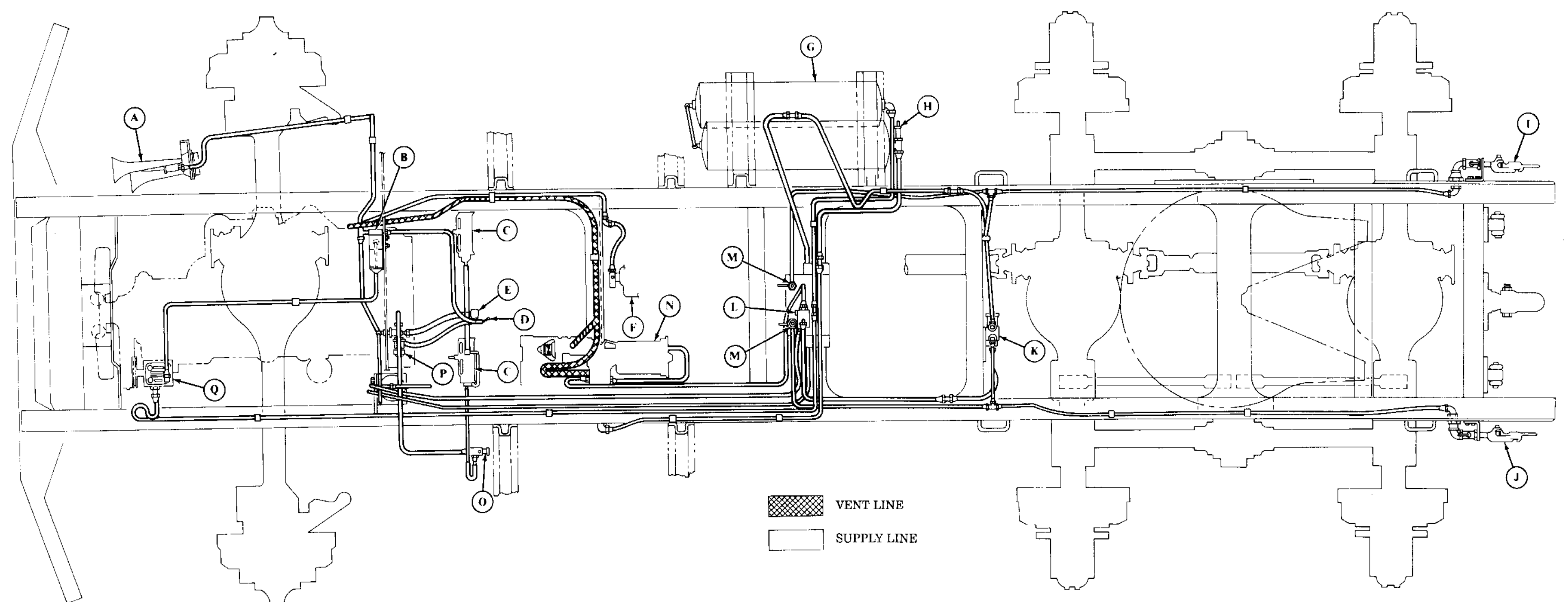

- |                                  |  |                                 |                            |                                     |
|----------------------------------|--|---------------------------------|----------------------------|-------------------------------------|
| (A) AIR HORN                     | (E) AIR PRESSURE GAGE                  | (I) REAR EMERGENCY AIR COUPLING | (L) SHUTTLE VALVE          | (O) WINDSHIELD WIPER SWITCH         |
| (B) GOVERNOR                     | (F) FRONT AXLE ENGAGEMENT AIR CYLINDER | (J) REAR SERVICE AIR COUPLING   | (M) CUTOFF VALVES          | (P) LOW AIR PRESSURE WARNING SWITCH |
| (C) WINDSHIELD WIPER MOTORS      | (G) AIR RESERVOIRS                     | (K) PROTECTION VALVE            | (N) AIR-HYDRAULIC CYLINDER | (Q) AIR COMPRESSOR                  |
| (D) FRONT AXLE ENGAGEMENT SWITCH | (H) SAFETY VALVE                       |                                 |                            |                                     |

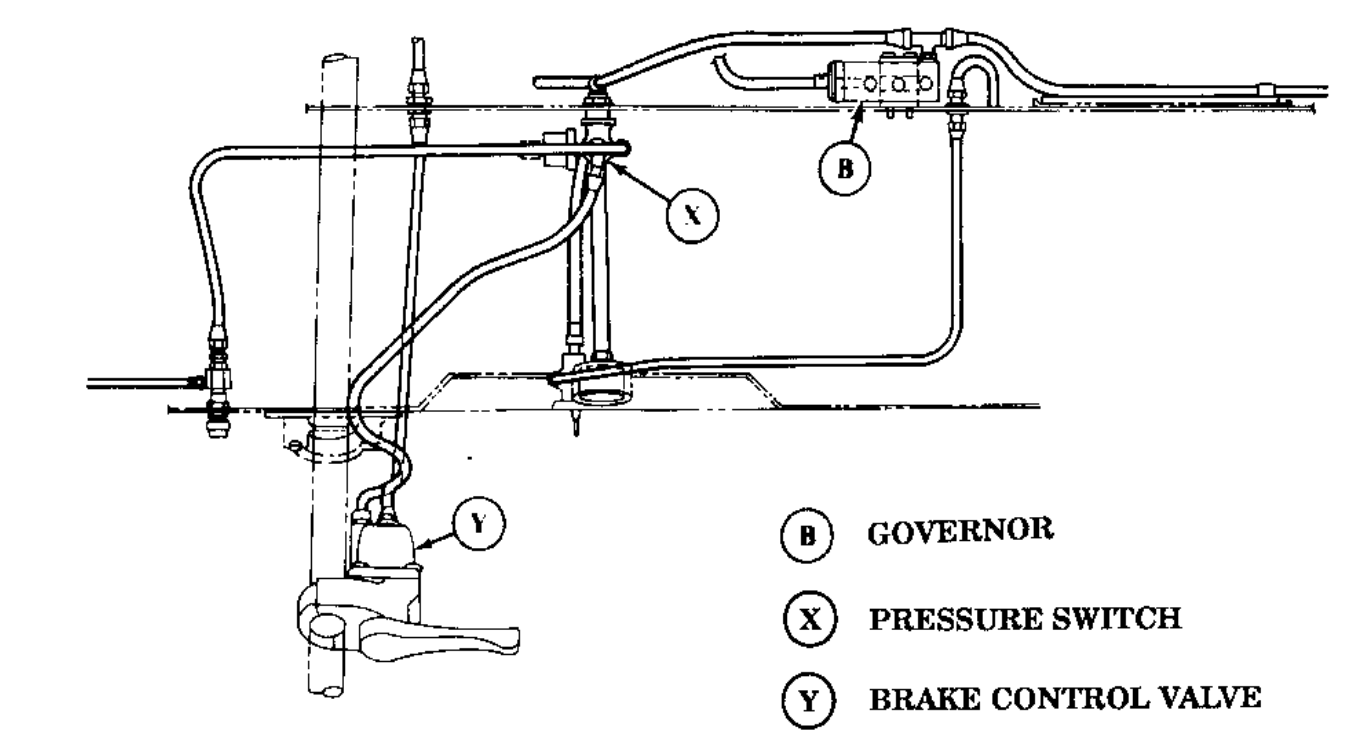
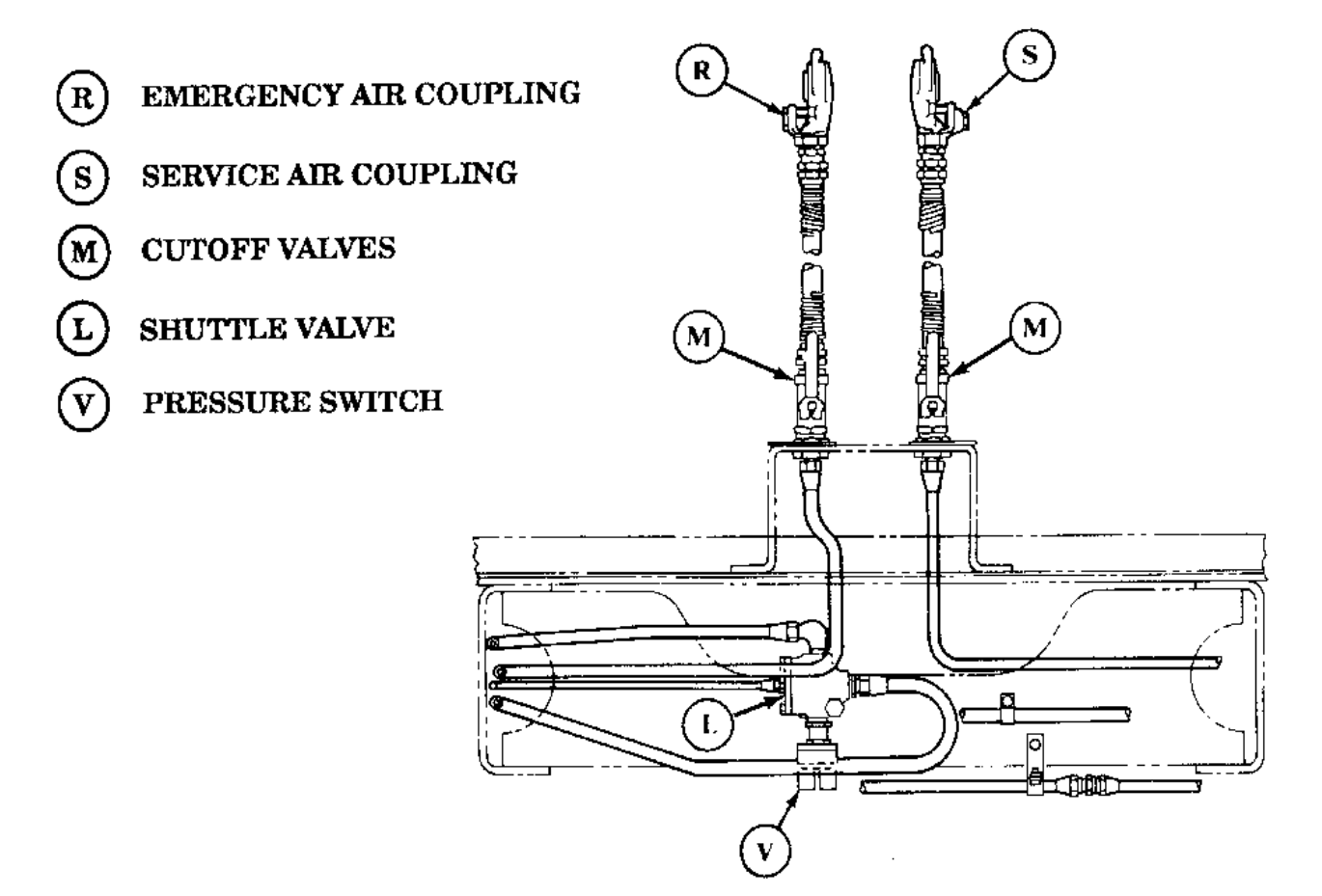

- |                         |
|-------------------------|
| (B) GOVERNOR            |
| (X) PRESSURE SWITCH     |
| (Y) BRAKE CONTROL VALVE |

Foldout 7. Compressed Air System - M275A2

# THE METRIC SYSTEM AND EQUIVALENTS

## LINEAR MEASURE

1 Centimeter = 10 Millimeters = 0.01 Meters = 0.3937 Inches  
 1 Meter = 100 Centimeters = 1,000 Millimeters = 39.37 Inches  
 1 Kilometer = 1,000 Meters = 0.621 Miles

## WEIGHTS

1 Gram = 0.001 Kilograms = 1,000 Milligrams = 0.035 Ounces  
 1 Kilogram = 1,000 Grams = 2.2 Lb  
 1 Metric Ton = 1,000 Kilograms = 1 Megagram = 1.1 Short Tons

## LIQUID MEASURE

1 Milliliter = 0.001 Liters = 0.0338 Fluid Ounces  
 1 Liter = 1,000 Milliliters = 33.82 Fluid Ounces

## SQUARE MEASURE

1 Sq Centimeter = 100 Sq Millimeters = 0.155 Sq Inches  
 1 Sq Meter = 10,000 Sq Centimeters = 10.76 Sq Feet  
 1 Sq Kilometer = 1,000,000 Sq Meters = 0.386 Sq Miles

## CUBIC MEASURE

1 Cu Centimeter = 1,000 Cu Millimeters = 0.06 Cu Inches  
 1 Cu Meter = 1,000,000 Cu Centimeters = 35.31 Cu Feet

## TEMPERATURE

$5/9 (^{\circ}\text{F} - 32) = ^{\circ}\text{C}$   
 212° Fahrenheit is equivalent to 100° Celsius  
 90° Fahrenheit is equivalent to 32.2° Celsius  
 32° Fahrenheit is equivalent to 0° Celsius  
 $9/5 \text{ C} + 32 = \text{F}^{\circ}$

## APPROXIMATE CONVERSION FACTORS

### TO CHANGE

Inches .....  
 Feet .....  
 Yards .....  
 Miles .....  
 Square Inches .....  
 Square Feet .....  
 Square Yards .....  
 Square Miles .....  
 Acres .....  
 Cubic Feet .....  
 Cubic Yards .....  
 Fluid Ounces .....  
 Pints .....  
 Quarts .....  
 Gallons .....  
 Ounces .....  
 Pounds .....  
 Short Tons .....  
 Pound-Feet .....  
 Pounds Per Square Inch .....  
 Miles Per Gallon .....  
 Miles Per Hour .....

### TO

Centimeters .....  
 Meters .....  
 Meters .....  
 Kilometers .....  
 Square Centimeters .....  
 Square Meters .....  
 Square Meters .....  
 Square Kilometers .....  
 Square Hectometers .....  
 Cubic Meters .....  
 Cubic Meters .....  
 Milliliters .....  
 Liters .....  
 Liters .....  
 Liters .....  
 Grams .....  
 Kilograms .....  
 Metric Tons .....  
 Newton-Meters .....  
 Kilopascals .....  
 Kilometers Per Liter .....  
 Kilometers Per Hour .....

### MULTIPLY BY

2.540  
 0.305  
 0.914  
 1.609  
 6.451  
 0.093  
 0.836  
 2.590  
 0.405  
 0.028  
 0.765  
 29.573  
 0.473  
 0.946  
 3.785  
 28.349  
 0.454  
 0.907  
 1.356  
 6.895  
 0.425  
 1.609

### TO CHANGE

Centimeters .....  
 Meters .....  
 Meters .....  
 Kilometers .....  
 Square Centimeters .....  
 Square Meters .....  
 Square Meters .....  
 Square Kilometers .....  
 Square Hectometers .....  
 Cubic Meters .....  
 Cubic Meters .....  
 Milliliters .....  
 Liters .....  
 Liters .....  
 Liters .....  
 Grams .....  
 Kilograms .....  
 Metric Tons .....  
 Newton-Meters .....  
 Kilopascals .....  
 Kilometers Per Liter .....  
 Kilometers Per Hour .....

### TO

Inches .....  
 Feet .....  
 Yards .....  
 Miles .....  
 Square Inches .....  
 Square Feet .....  
 Square Yards .....  
 Square Miles .....  
 Acres .....  
 Cubic Feet .....  
 Cubic Yards .....  
 Fluid Ounces .....  
 Pints .....  
 Quarts .....  
 Gallons .....  
 Ounces .....  
 Pounds .....  
 Short Tons .....  
 Pound-Feet .....  
 Pounds Per Square Inch .....  
 Miles Per Gallon .....  
 Miles Per Hour .....

### MULTIPLY BY

0.394  
 3.280  
 1.094  
 0.621  
 0.155  
 10.764  
 1.196  
 0.386  
 2.471  
 35.315  
 1.308  
 0.034  
 2.113  
 1.057  
 0.264  
 0.035  
 2.205  
 1.102  
 0.738  
 0.145  
 2.354  
 0.621

